

We are IntechOpen, the world's leading publisher of Open Access books Built by scientists, for scientists

4,800

Open access books available

122,000

International authors and editors

135M

Downloads

Our authors are among the

154

Countries delivered to

TOP 1%

most cited scientists

12.2%

Contributors from top 500 universities



WEB OF SCIENCE™

Selection of our books indexed in the Book Citation Index
in Web of Science™ Core Collection (BKCI)

Interested in publishing with us?
Contact book.department@intechopen.com

Numbers displayed above are based on latest data collected.

For more information visit www.intechopen.com



Fault Detection and Isolation Scheme Based on Parity Space Method for Discrete Time-Delay System

Hongyu Wang, Zuohua Tian, Songjiao Shi and Zhenxin Weng
*Shanghai Jiaotong University
China*

1. Introduction

In recent years, fault detection and isolation (FDI) problem in dynamic system has been paid more and more attention. A great number of methods for FDI have been proposed (Chow & Willsky, 1984; Frank & Ding, 1997; Chen & Patton, 1999; Patton et al., 2000; Venkatasubramanian et al., 2003). All of the FDI schemes are concerned with a core stage: the generation of the residual signals. The difference between the measurement of the system and its estimation is called residual, whose values are zero or near to zero when no fault occurs while differ distinctly from zero otherwise. Appropriate decisions such as the occurrence, magnification, type, location, etc. of the faults are called fault isolation, which are achieved by residual evaluation.

In the field of analytical model-based FDI techniques, the analytical redundancy relations of the system are used to create residual signal. The approaches can be roughly classified into observer-based approaches and parameter estimation approaches. Parity space approaches have been proved to be structurally equivalent to the observer-based though the design procedures differ (Gertler, 1991). However, the parity space methodology using the temporal redundancy has its advantages, especially in the discrete system. This method was firstly generalized by the (Chow & Willsky, 1984).

Time delays are inherent in many real physical processes (i.e. mechanical and chemical processes, long transmission lines in pneumatic systems, power and water distribution networks, air pollution systems etc.) Over the past two decades, analysis and synthesis of dynamic time-delay systems have attracted a great deal of interests (Dugard & Verriest, 1997; Yang & Saif, 1998). However, there are relative fewer research results on FDI of time-delay systems (KRATZ et al., 1998; Zhong et al., 2004).

This paper proposes a method to deal with the FDI problem for the linear discrete-time systems with delays. The results in (KRATZ et al., 1998) are extended. Both fault detection and fault isolation method are proposed. The occurrence of the fault can be detected timely and the position of the fault can be located exactly. A numerical example is given to illustrate the design method at the end.

2. Mathematical Preliminaries

A time delay operator ∇ is defined according to (KRATZ et al., 1998). $\nabla f(k) = f(k-1)$ for any discrete-time function f . It is easy to understand that $\nabla \nabla f(k) = \nabla^2 f(k) = f(k-2)$, $\nabla^w f(k) = f(k-w)$.

Consider a linear discrete time-delay system described by

$$\begin{cases} \mathbf{x}(k+1) = \sum_{i=0}^v \mathbf{A}_i \mathbf{x}(k-i) + \mathbf{B}[\mathbf{u}(k) + \mathbf{f}_a(k)] + \mathbf{E}_d \mathbf{d}(k) \\ \mathbf{y}(k) = \mathbf{C} \mathbf{x}(k) + \mathbf{F}_d \mathbf{d}(k) \end{cases} \quad (1)$$

where $\mathbf{x}(k) \in R^n$ is the state vector, $\mathbf{u}(k) \in R^p$ is the control vector, $\mathbf{y}(k) \in R^m$ is the output vector, $\mathbf{f}_a(k) = [f_{a1}(k), \dots, f_{ap}(k)]^T$ stands for the actuator faults. $f_{ai}(k)$, $i=1, \dots, p$ is corresponding to the i th actuator fault. $\mathbf{d}(k) \in R^l$ is disturbance vector, $\|\mathbf{d}(k)\| < \bar{d}$. \mathbf{A}_i ($i=0, \dots, v$), \mathbf{B} , \mathbf{C} , \mathbf{E}_d and \mathbf{F}_d are constant matrices with appropriate dimensions. Integers $v \geq 0$ denotes the number of time delays in the state.

Using the operator ∇ , the system (1) can be rewritten as

$$\begin{cases} \mathbf{x}(k+1) = \mathbf{A}(\nabla) \mathbf{x}(k) + \mathbf{B}[\mathbf{u}(k) + \mathbf{f}_a(k)] + \mathbf{E}_d \mathbf{d}(k) \\ \mathbf{y}(k) = \mathbf{C} \mathbf{x}(k) + \mathbf{F}_d \mathbf{d}(k) \end{cases} \quad (2)$$

where,

$$\mathbf{A}(\nabla) = \mathbf{A}_0 + \mathbf{A}_1 \nabla + \dots + \mathbf{A}_v \nabla^v \quad (3)$$

3. Parity Space Residual Generation for Fault Detection and Isolation

The task of FDI is to design a residual signal which is zero or near to zero in a fault free case and non-zero when a fault occurs in the monitored system. Time delay implies that the state of the system for the next time step is not only determined by the current state but also concerned with the state of the former intervals. The recursion of equation (2) from time instant $k-L$ to time instant k yields

$$\mathbf{y}_L = \mathbf{H}_{o,L} \mathbf{x}(k-L) + \mathbf{H}_{u,L} \mathbf{u}_L + \mathbf{H}_{d,L} \mathbf{d}_L + \mathbf{H}_{fa,L} \mathbf{f}_{aL} \quad (4)$$

where

It should be noted that the parity vectors \mathbf{v}_L satisfying equation (5) are not unique, and the corresponding residual signals $r_L(k)$ are not unique. The freedom of the \mathbf{v}_L can be used to create specific residual signals, so as to fulfill specific design purposes.

The parity vectors \mathbf{v}_L can be described as $\mathbf{v}_L = [v_1, v_2, \dots, v_{(L+1)m}]$. Substituting it to equation (7), the terms corresponding to disturbance $\mathbf{v}_L \mathbf{H}_{d,L} \mathbf{d}_L(k)$ and faults $\mathbf{v}_L \mathbf{H}_{fa,L} \mathbf{f}_{aL}(k)$ can be respectively expanded as follows:

$$\mathbf{v}_L \mathbf{H}_{d,L} \mathbf{d}_L(k) = \psi_1 d_1(k) + \psi_2 d_2(k) + \dots + \psi_l d_l(k) \quad (8)$$

$$\mathbf{v}_L \mathbf{H}_{fa,L} \mathbf{f}_{aL}(k) = \omega_1 f_{a1}(k) + \omega_2 f_{a2}(k) + \dots + \omega_p f_{ap}(k) \quad (9)$$

Where $\psi_1, \psi_2, \dots, \psi_p, \omega_1, \omega_2, \dots, \omega_p$ are polynomials corresponding to $v_1, v_2, \dots, v_{(L+1)m}$ and ∇ .

The successful detection of a fault is followed by the fault isolation procedure which will distinguish (isolate) a particular fault from others. While a single residual signal is sufficient to detect faults, a set of residuals (or a vector of residual) is usually required for fault isolation. According to (Chen & Patton, 1999), a commonly used scheme in designing the residual set is to make each residual sensitive to all but one fault, i.e.

$$\begin{cases} r_1 = R(f_{a2}, \dots, f_{ap}) \\ \vdots \\ r_i = R(f_{a1}, \dots, f_{ai-1}, f_{ai+1}, \dots, f_{ap}) \\ \vdots \\ r_p = R(f_{a1}, \dots, f_{ap-1}) \end{cases} \quad (10)$$

where $R(\cdot)$ denotes some functional relation, which works as the residual generator. This is defined as a generalized structured residual set. The isolation can be performed by the following logic:

$$\left. \begin{array}{l} \|r_i\| \leq th^i \\ \|r_j\| > th^j \text{ for } j = 1, \dots, i-1, i+1, \dots, p \end{array} \right\} \Rightarrow f_{ai} \neq 0 \quad (11)$$

where th^i means the fault isolation threshold to the corresponding fault.

To achieve the so called generalized structured residual set, let $\omega_1, \omega_2, \dots, \omega_p$ satisfy the following equations:

$$\begin{cases} \omega_1 \neq 0 \\ \vdots \\ \omega_{i-1} \neq 0, i = 1, 2, \dots, p \\ \omega_i = 0 \\ \omega_{i+1} \neq 0 \end{cases} \quad (12)$$

Solving the equations (12) respectively can achieve a set of parity vectors \mathbf{v}_{Lfa_i} $i = 1, 2, \dots, p$, which lead to a set of residual signals $r_{Lfa_i}(k)$, $i = 1, 2, \dots, p$ by equation (6). When the i th actuator fault occurs ($f_{ai}(k) \neq 0$), the corresponding residual signal $r_{Lfa_i}(k)$ is not affected, while the other residual signals $r_{Lfa_1}(k), r_{Lfa_2}(k), \dots, r_{Lfa_{i-1}}(k), r_{Lfa_{i+1}}(k), r_{Lfa_p}(k)$ are affected. The isolation can be fulfilled by equation (11).

4. Numerical Example

To illustrate the design process of the proposed method and verify its effectiveness, the following numerical example is demonstrated. Consider a time delay system of the form (1),

$$\begin{cases} \begin{bmatrix} x_1(k+1) \\ x_2(k+1) \\ x_3(k+1) \end{bmatrix} = \begin{bmatrix} 0.15 & 0.324 & 0 \\ 0.102 & 0.258 & 0 \\ 0 & 0 & 0.412 \end{bmatrix} \begin{bmatrix} x_1(k) \\ x_2(k) \\ x_3(k) \end{bmatrix} + \begin{bmatrix} 0 & 0.265 & 0 \\ -0.406 & 0 & 0.308 \\ 0 & -0.252 & 0.124 \end{bmatrix} \begin{bmatrix} x_1(k-1) \\ x_2(k-1) \\ x_3(k-1) \end{bmatrix} \\ + \begin{bmatrix} 1 & 0 & 0 \\ 0 & 1 & 0 \\ 0 & 0 & 1 \end{bmatrix} \left(\begin{bmatrix} u_1(k) \\ u_2(k) \\ u_3(k) \end{bmatrix} + \begin{bmatrix} f_{a1}(k) \\ f_{a2}(k) \\ f_{a3}(k) \end{bmatrix} \right) + \begin{bmatrix} 1 \\ 1 \\ 1 \end{bmatrix} d(k) \\ \begin{bmatrix} y_1(k) \\ y_2(k) \\ y_3(k) \end{bmatrix} = \begin{bmatrix} 1 & 0 & 0 \\ 0 & 1 & 0 \\ 0 & 0 & 1 \end{bmatrix} \begin{bmatrix} x_1(k) \\ x_2(k) \\ x_3(k) \end{bmatrix} + \begin{bmatrix} 1 \\ 1 \\ 1 \end{bmatrix} d(k) \end{cases}$$

Where $d(k) = 0.01 \times randN(0,1)$, $randN(0,1)$ stands for zero mean, unit Gauss noise. Using the operator ∇ , the system (1) can be rewritten into the form (2), the system matrix is:

$$A(\nabla) = \begin{bmatrix} 0.15 & 0.324 + 0.265\Delta & 0 \\ 0.102 - 0.406\Delta & 0.258 & 0.308\Delta \\ 0 & -0.252\Delta & 0.412 + 0.124\Delta \end{bmatrix}$$

In order to fulfill the FDI, a parity space with $L = 2$ is established, the matrix $H_{o,L}$, $H_{u,L}$, etc. can be computed using the software MAPLE. Solving the equation (5) can get the parity vector:

$$v_L = \begin{bmatrix} t_1 \\ \begin{pmatrix} 1.767\nabla t_1 + 2.160t_1 - 0.03768t_2 - 0.7173\nabla^2 t_2 - 0.6968\nabla t_2 + 0.2520\nabla t_3 \\ -0.01221t_4 - 0.2357\nabla t_4 - 0.1901\nabla^3 t_4 - 0.4170\nabla^2 t_4 - 0.1074\nabla^2 t_5 - 0.009721t_5 \\ -0.1798\nabla t_5 + 0.1133\nabla t_6 + 0.2068\nabla^2 t_6 + 0.1807512\nabla^3 t_6 \end{pmatrix} \\ \begin{pmatrix} -0.308\nabla t_2 - 0.412t_3 - 0.124\nabla t_3 - 0.09979\nabla t_4 - 0.08162\nabla^2 t_4 - 0.2064\nabla t_5 - \\ 0.03819\nabla^2 t_5 + 0.06224\nabla^2 t_6 - 0.1023\nabla t_6 - 0.1697t_6 \end{pmatrix} \\ \begin{pmatrix} -6.667t_1 - 0.6800t_2 + 2.7067\nabla t_2 - 0.3703t_4 + 0.6968\nabla t_4 + 0.7173\nabla^2 t_4 + 1.104\nabla t_5 \\ -0.2774t_5 - 0.6821\nabla^2 t_6 + 0.1714\nabla t_6 \end{pmatrix} \\ t_2 \\ t_3 \\ t_4 \\ t_5 \\ t_6 \end{bmatrix}^T \quad (13)$$

Where $t_1, t_2, t_3, t_4, t_5, t_6 \in R$ and $t_1, t_2, t_3, t_4, t_5, t_6$ are not all zeros. v_L is a row 9 dimensions vector with 6 freedom.

In order to achieve fault detection and isolation, a generalized residual set consists in three residual signals should be created as show in Fig.1.

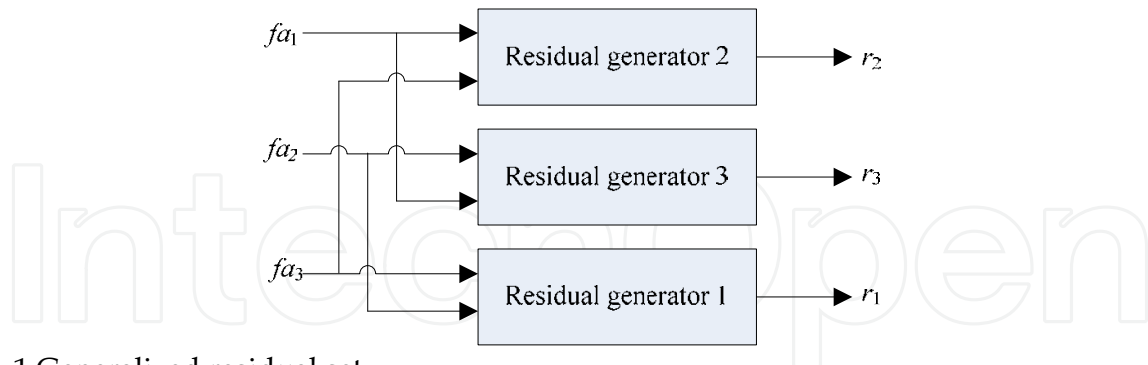

Fig. 1 Generalized residual set

In Fig.1, f_{a_i} stands for the i th actuator fault. Residual signal r_1 is sensitive to f_{a_2} and f_{a_3} while insensitive to f_{a_1} . The situation of r_2 and r_3 are the same with r_1 .

Substituting v_L to equation (7), and expanding the terms corresponding to the actuator fault $v_L \mathbf{H}_{f_{a_i}} f_{a_i}(k)$ into equation (9) yields, $v_L \mathbf{H}_{f_{a_i}} f_{a_i}(k) = \omega_1 f_{a_1}(k) + \omega_2 f_{a_2}(k) + \omega_3 f_{a_3}(k)$. Where $\omega_1, \omega_2, \omega_3$ are polynomials corresponding to $t_1, t_2, t_3, t_5, t_5, t_6$ and ∇ . Using equation (12), let

$$\begin{cases} \omega_1 = 0 \\ \omega_2 \neq 0 \\ \omega_3 \neq 0 \end{cases}$$

$t_1, t_2, t_3, t_5, t_5, t_6$ can be achieved by solving the above equation, and substituting them into (13) can get the parity vector corresponding to the first actuator fault f_{a_1} :

$$v_{L f_{a_1}} = \begin{bmatrix} 0 \\ 0.2520\Delta + 0.07762\Delta^2 \\ -0.4120 - 0.2509\Delta - 0.03819\Delta^2 \\ -0.1020 + 0.4060\Delta \\ -0.2580 \\ 1 \\ 0 \\ 1 \\ 0 \end{bmatrix}^T$$

Substituting $v_{L f_{a_1}}$ to equation (6) can get generalized residual signal $r_{L f_{a_1}}(k)$ corresponding to f_{a_1} , denoted by r_1 .

$$r_1 = (-0.1020\Delta + 0.4060\Delta^2)y_1(k) + (1 - 0.2580\Delta + 0.2520\Delta^3 + 0.07762\Delta^4)y_2(k) + (\Delta - 0.4120\Delta^2 - 0.2509\Delta^3 - 0.03819\Delta^4)y_3(k) + (-\Delta)u_2(k) + (-\Delta^2 - 0.3080\Delta^3)u_3(k)$$

By the same process, let

$$\begin{cases} \omega_1 \neq 0 \\ \omega_2 = 0, \\ \omega_3 \neq 0 \end{cases}, \begin{cases} \omega_1 \neq 0 \\ \omega_2 \neq 0 \\ \omega_3 = 0 \end{cases}$$

The residual signals correspond to f_{a2} and f_{a3} can be designed, denoted by r_2 and r_3 .

Now, the design of the generalized residual set for actuator fault detection and isolation is accomplished. The result of the simulation is shown in Fig. 2 to Fig. 5.

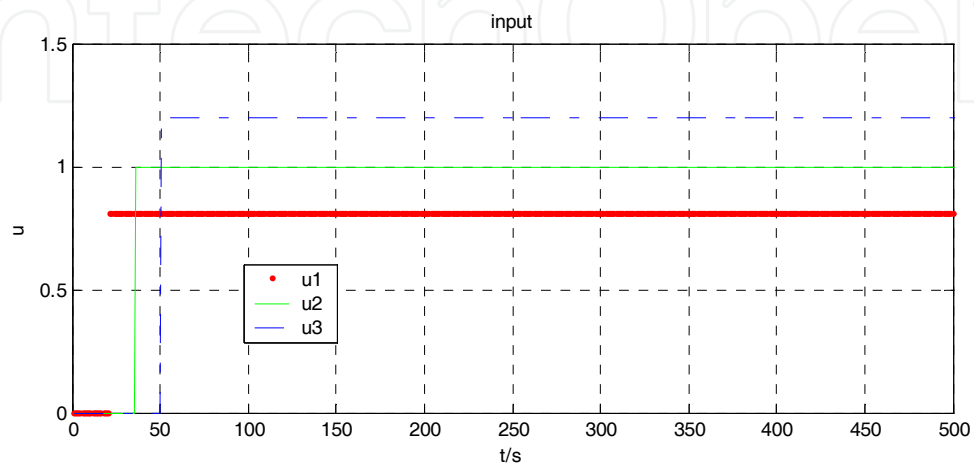

Fig. 2 System input signals

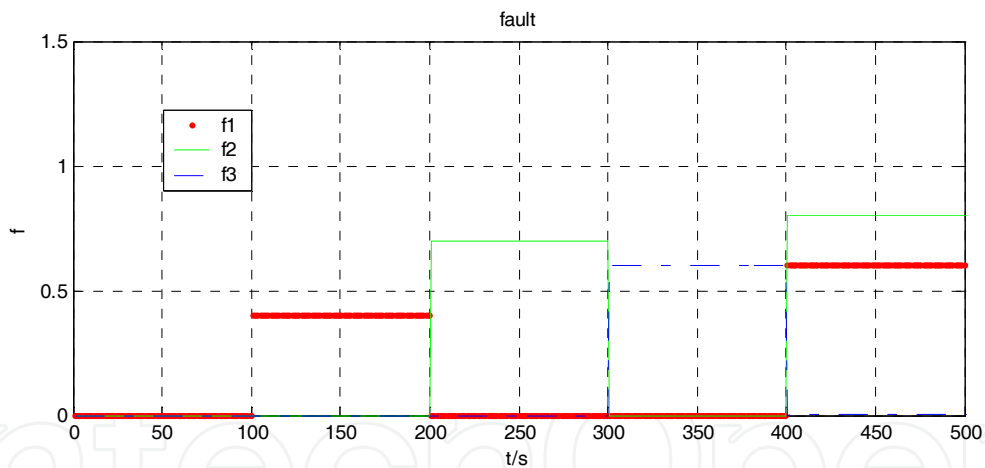

Fig. 3 Fault signals

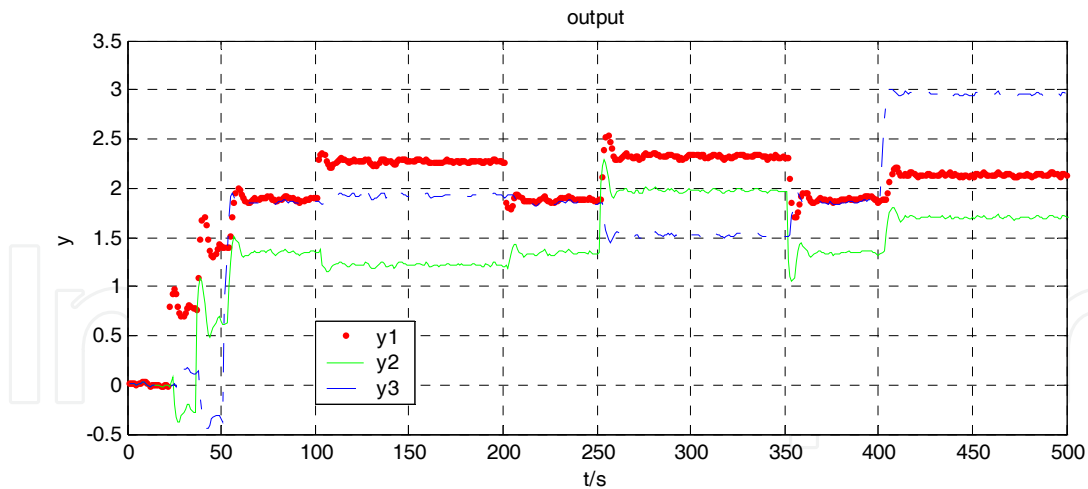

Fig. 4 System output signals

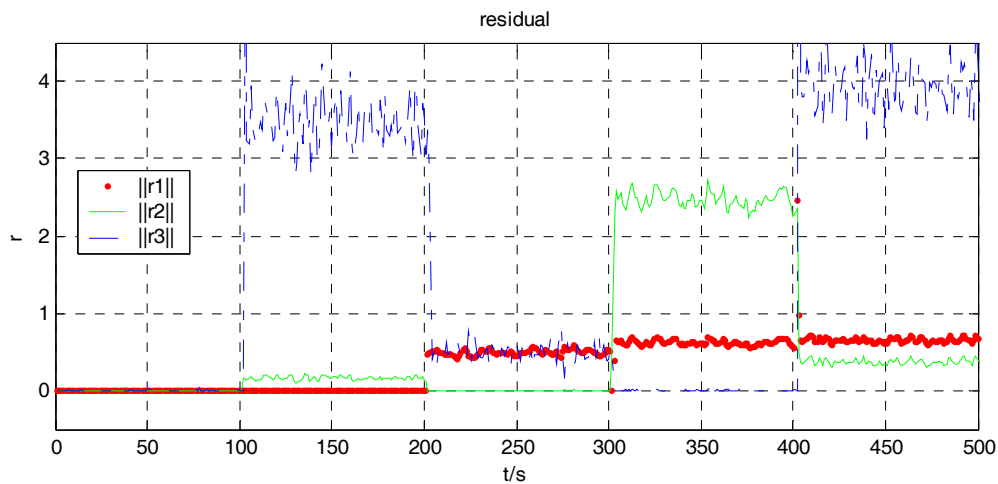

Fig. 5 Residual signals

There are 5 stages in the simulation process:

1. from time 0 second to time 100 second, the system works properly. $\|r_1\|$, $\|r_2\|$ and $\|r_3\|$ are near to zero.
2. from time 100 second to time 200 second, the actuator 1 suffers from fault, while actuator 2 and actuator 3 work properly. $\|r_2\|$ and $\|r_3\|$ differ from zero while $\|r_1\|$ keeps zero nearby.
3. from time 200 second to time 300 second, the actuator 2 suffers from fault, while actuator 1 and actuator 3 work properly. $\|r_1\|$ and $\|r_3\|$ differ from zero while $\|r_2\|$ keeps zero nearby.
4. from time 300 second to time 400 second, the actuator 3 suffers from fault, while actuator 1 and actuator 2 work properly. $\|r_1\|$ and $\|r_2\|$ differ from zero while $\|r_3\|$ keeps zero nearby.
5. from time 400 second to time 500 second, the actuator 1 and actuator 2 suffer from fault at the same time, while actuator 3 works properly. $\|r_1\|$, $\|r_2\|$ and $\|r_3\|$ differ from zero simultaneously.

It can be concluded that when there is one actuator goes into fault, the above generalize residual set based on parity space can detect the fault and isolate which actuator corrupted by the fault. However, when there are more than one actuators break into faults, the method can only detect the fault, while it have no idea that which actuators corrupted by the fault.

5. Conclusion

A fault detection and isolation scheme for discrete time-delay system has been proposed in this chapter. The scheme can not only detect the faults but also isolate (locate) the faults. To fulfill the FDI, a generalized residual set in form of parity space is designed by the recursion of the system equations. Each residual is sensitive to all but one actuator faults. The actuator with fault can be isolated from the normal ones exactly. A time delay operator is used to deal with the problem brought by the time-delay system. The effectiveness of the proposed method has been verified by a numerical example.

However, further studies are required which include the follow aspects:

1. To determine an optimal recursion step L . Such that the residuals can obtain a certain freedom to complete fault isolation, while the computation is minimized.
2. To extend the fault isolation result. The sensor faults and the actuator faults should be discerned.
3. To enhance the reliability and robust performance of the FDI system.

6. References

- Chen, J.; Patton, R. J. (1999). *Robust Model-based Fault Diagnosis for Dynamic Systems*, Kluwer Academic Publishers
- Chow, E. Y.; Willsky, A. S. (1984). Analytic redundancy and the design of robust fault detection systems. *IEEE Transaction on Automatic Control*, Vol. 29, Jul. 1984, 603-614
- Dugard, L.; Verriest, E. I. (1997). *Stability and Control of Time-delay Systems. Lecture Notes in Control and Information Sciences*, Springer
- Frank, P. M.; Ding, X. (1997). Survey of robust residual generation and evaluation methods in observer-based fault detection systems. *Journal of Process Control*, Vol. 7, Jun. 1997 pp. 403-424
- Gertler, J. Li, B. (1991). Analytical redundancy methods in fault detection and isolation, *Proceedings of the IFAC/IMACS Symposium SAFEPROCESS 9*, pp. 9-21, Baden-Baden 1991
- KRATZ, F.; NUNINGER, W. & PLOIX, S. (1998). Fault detection for time-delay systems: a parity space approach, *Proceedings of the American Control Conference*, pp. 2009-2011, Philadelphia, Pennsylvania, 1998
- Patton, R. J.; Frank, P. M. and Clark, R. N. (2000). *Issues of Fault Diagnosis for Dynamic Systems*, Springer
- Venkatasubramanian, V.; Rengaswamy, R.; Yin, K. and Kavuri, Surya N. (2003). S A review of process fault detection and diagnosis: Part I: quantitative model-based methods. *Computers and Chemical Engineering*, Vol. 27, 2003 pp. 293-311
- Yang, H.; Saif, M. (1998). Observer design and fault diagnosis for state retarded dynamical systems. *Automatica*, Vol. 34, Feb. 1998 pp. 217-227

Zhong, M.; Ye, H. & Wang, G. (2004). Multi-freedom design of fault detection filter for linear time-delay systems, *Proceedings of 2004 8th International Conference on Control, Automation, Robotics and Vision*, pp. 1630-1634, Kunming, China, 2004

IntechOpen

IntechOpen



Fault Detection

Edited by Wei Zhang

ISBN 978-953-307-037-7

Hard cover, 504 pages

Publisher InTech

Published online 01, March, 2010

Published in print edition March, 2010

In this book, a number of innovative fault diagnosis algorithms in recently years are introduced. These methods can detect failures of various types of system effectively, and with a relatively high significance.

How to reference

In order to correctly reference this scholarly work, feel free to copy and paste the following:

Hongyu Wang, Zuohua Tian, Songjiao Shi and Zhenxin Weng (2010). Fault Detection and Isolation Scheme Based on Parity Space Method for Discrete Time-Delay System, Fault Detection, Wei Zhang (Ed.), ISBN: 978-953-307-037-7, InTech, Available from: <http://www.intechopen.com/books/fault-detection/fault-detection-and-isolation-scheme-based-on-parity-space-method-for-discrete-time-delay-system>

INTECH
open science | open minds

InTech Europe

University Campus STeP Ri
Slavka Krautzeka 83/A
51000 Rijeka, Croatia
Phone: +385 (51) 770 447
Fax: +385 (51) 686 166
www.intechopen.com

InTech China

Unit 405, Office Block, Hotel Equatorial Shanghai
No.65, Yan An Road (West), Shanghai, 200040, China
中国上海市延安西路65号上海国际贵都大饭店办公楼405单元
Phone: +86-21-62489820
Fax: +86-21-62489821

© 2010 The Author(s). Licensee IntechOpen. This chapter is distributed under the terms of the [Creative Commons Attribution-NonCommercial-ShareAlike-3.0 License](#), which permits use, distribution and reproduction for non-commercial purposes, provided the original is properly cited and derivative works building on this content are distributed under the same license.

IntechOpen

IntechOpen