

# We are IntechOpen, the world's leading publisher of Open Access books Built by scientists, for scientists

4,800

Open access books available

122,000

International authors and editors

135M

Downloads

Our authors are among the

154

Countries delivered to

TOP 1%

most cited scientists

12.2%

Contributors from top 500 universities



WEB OF SCIENCE™

Selection of our books indexed in the Book Citation Index  
in Web of Science™ Core Collection (BKCI)

Interested in publishing with us?  
Contact [book.department@intechopen.com](mailto:book.department@intechopen.com)

Numbers displayed above are based on latest data collected.

For more information visit [www.intechopen.com](http://www.intechopen.com)



# UWB and SWB Planar Antenna Technology

Shun-Shi Zhong

*School of communication and Information Engineering,  
Shanghai University, Shanghai 200072  
China*

## 1. Introduction

Various wideband antennas have been interesting subjects in antenna designs and have found important applications in military and civilian systems. For examples, the super-wideband (SWB) antenna is a key component of electronic counterwork equipment in the information warfare; while the ultra-wideband (UWB) antenna is widely used in impulse radar and communication systems. With the development of high-speed integrated circuits, and the requirement of the miniaturization and integration, the research and application of UWB/SWB planar antennas have been growing rapidly. On February 14, 2002, the Federal Communications Commission (FCC) in the United States allocated the 3.1-10.6GHz spectrum for commercial application of UWB technology, which has sparked renewed attention in the research of ultra-wideband planar antennas. Fig.1 shows its some applications.

It is worth noting that the actual frequency range of an indoor UWB communication antenna in the provision of UWB technology is from 3.1 to 10.6GHz with a ratio bandwidth of 3.4:1, while the antenna with a ratio bandwidth not less than 10:1 is generally called the super-wideband (SWB) antenna in antenna engineering. Both types are reviewed and for simplification, usually they are called the UWB antenna in this chapter. In the UWB system, the former operates just like a kind of pulse figuration filter, which requires the antenna to radiate pulses without distortion. To that end, the UWB antenna should not only possess an ultra-wide impedance bandwidth, but also have good phase linearity and a stable radiation pattern. Hence, for this sort of UWB antenna some particular considerations are entailed [1].

The earliest antenna with wideband properties is the biconical antenna executed by Oliver Lodge in 1898, as shown in Fig.2a. It can be regarded as a uniformly tapered transmission line excited by TEM mode so as to possess the ultra-wideband input impedance properties. Its bandwidth is mainly influenced by the ending reflection due to its limited dimension. Following improvements consist of Carter's improved match biconical antenna ( Fig.2b) and conical monopole antenna (1939), Schelkunoff's spheroidal antenna (1941), Kandoian's disccone antenna (1945), Brillouin's omni-directional and directional coaxial horn antenna (1948), etc[2]. All these antennas are based on three-dimensional structures with bulky volume. In the late 1950s and early 1960s, a family of antennas with more than 10:1

bandwidth ratio was developed by V. Ramsey et al., which was called frequency-independent antenna<sup>[3]</sup>. Classical shapes of such antennas basically include the equiangular spiral antenna and the planar log-periodic dipole antennas, as shown in Fig.3. These designs reduce the volume, but the transfer of effective radiating region for the different frequencies results in waveform distortion in transmitting pulse. Later on, P.J. Gibson presented in 1979 the Vivaldi antenna, or called tapered slot antenna, as shown in Fig.4, which behaves like an endfire traveling wave antenna with a moderate gain and is of a super-wide bandwidth<sup>[4]</sup>.

From 1990s, many new-style ultra-wideband planar antennas have been proposed, which can be sum up as three types<sup>[5]</sup>, namely the Ultra-wideband planar metal-plate monopole antennas, the UWB printed monopole antennas and the UWB printed slot antennas. The progress in these three types of UWB planar antennas is introduced and compared below. In addition, the UWB printed antennas with the band-notched functions are also reviewed.



Fig. 1. Some applications of UWB systems

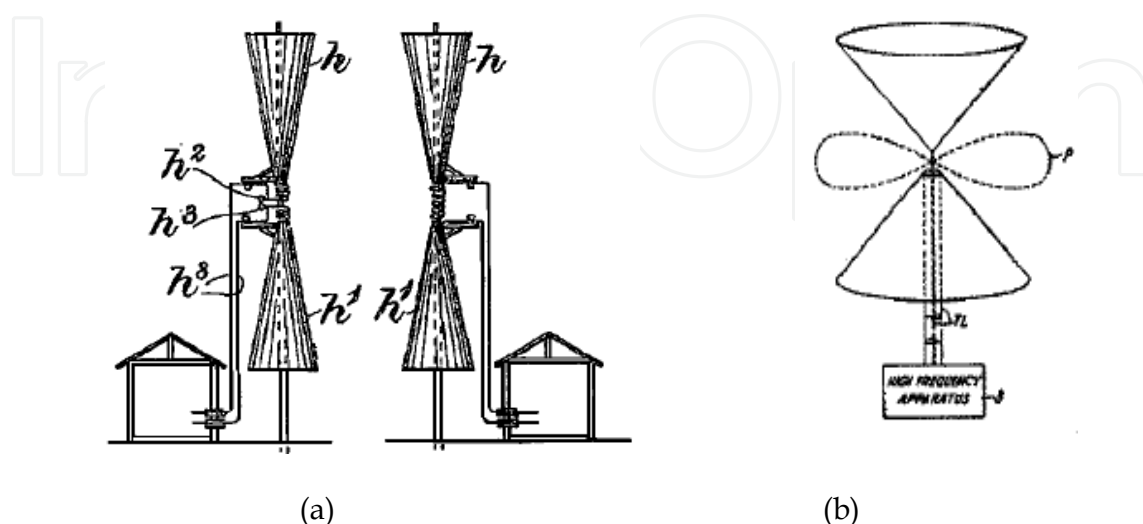

Fig. 2. Lodge's biconical antenna and Carter's improved match biconical antenna<sup>[2]</sup>

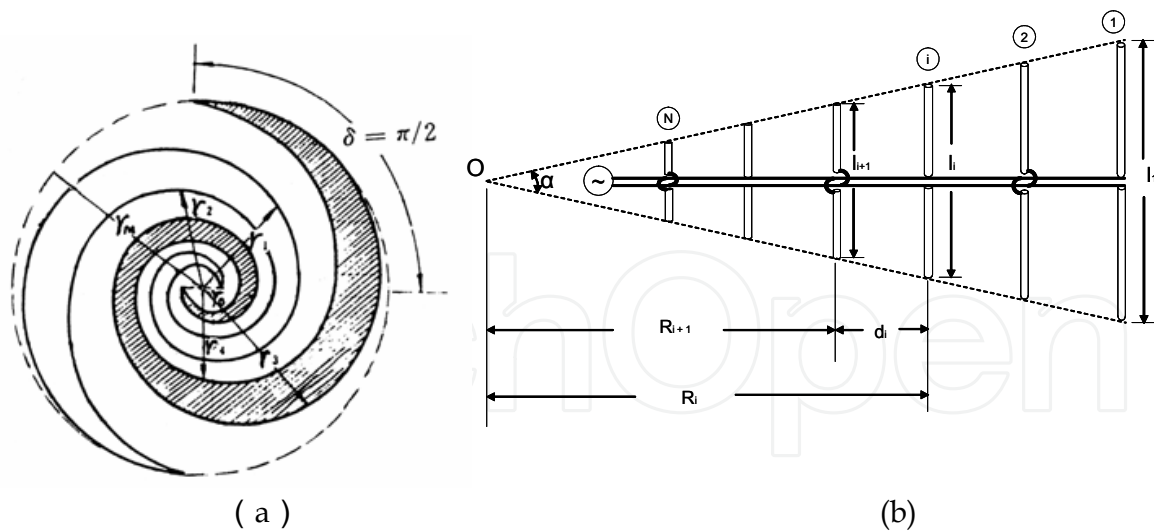

Fig. 3. Equiangular spiral antenna and log-periodic dipole antenna

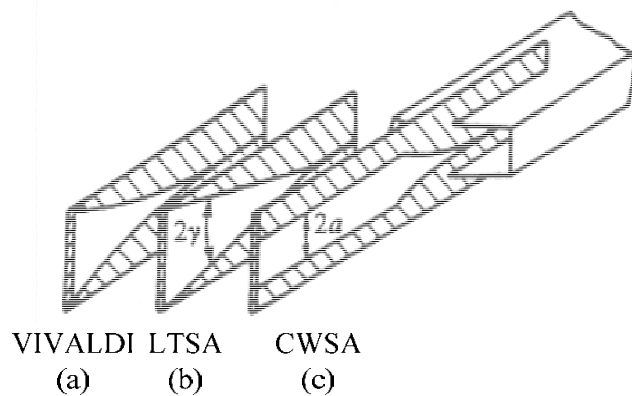

Fig. 4. Vivaldi-like antennas [4]

**2. UWB metal-plate monopole antennas**

The wideband metal-plate monopole antenna was first proposed by G. Dubost [6] in 1976 and continually developed. Its impedance bandwidth has been broadened by optimizing the structure of metal-plate monopole, such as discs or elliptical monopole antenna [7], trapezium monopole antenna[8], inverted cone monopole and leaf-shaped planar plate monopole antennas etc, as shown in Fig.5. The planar inverted cone antenna (PICA) designed by S.Y. Suh, as shown in Fig.5c [9], provides an impedance bandwidth ratio of more than 10:1, and a radiation pattern bandwidth of 4:1. The one with two circular holes has extended the radiation pattern bandwidth due to the effective changing of its surface current. In the author’s laboratory, another leaf-shaped plate monopole antenna with three circular holes was developed, as shown in Fig.5d [10]. It achieves the impedance bandwidth ratio better than 20:1, covering the frequency range from 1.3GHz to 29.7GHz. As is well known, the rectangular metal-plate monopole antenna is a wideband metal-plate monopole antenna with the simplest structure and a steady radiating pattern, but its impedance bandwidth is only about 2:1 in the early period. In order to realize the ultra-wideband

properties, many methods have been brought forward, such as using an offset feed, double or three feeds, shorting post with beveling technique, etc. P.V. Anob improved its impedance bandwidth to 6:1 by changing the location of the feeding [11]. M.J. Ammann widened the bandwidth to 10:1 ( $VSWR \leq 3$ ) by combining the short post and beveling technique [12], as shown in Fig.6. Some designs, such as double or three feeds in Fig.7, not only consumedly widen the impedance bandwidth, but also improve the stability of radiation pattern [13]. The Ultra-wideband metal-plate monopole antennas always need a perpendicular metal ground plane.

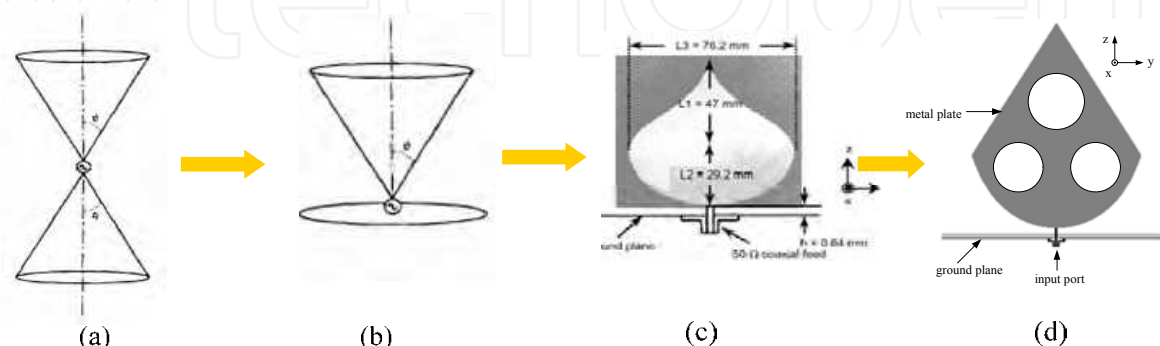

Fig. 5. Evolution from biconical antenna to metal-plate monopole antenna[5]

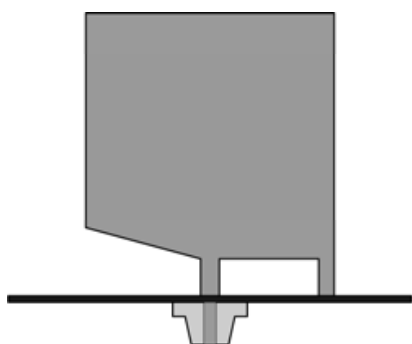

Fig. 6. Monopole antenna with short post[12]

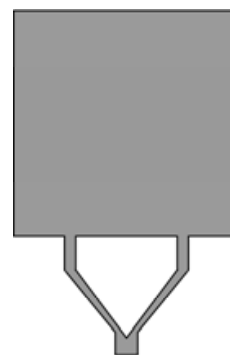

Fig. 7. Monopole antenna with double feeds [13]

### 3. UWB printed monopole antennas

The UWB printed monopole antenna consists of a monopole patch and a ground plane, both printed on the same or opposite side of a substrate, while a microstrip line or CPW is located in the middle of the ground plane to feed the monopole patch. Compared with the ultra-wideband metal-plate monopole antenna, the UWB printed monopole antenna does not need a perpendicular ground plane. Therefore, it is of smaller volume and is suitable for integrating with monolithic microwave integrated circuits (MMIC). To broaden the bandwidth of this kind of antennas, a number of monopole shapes have been developed, such as heart-shape, U-shape, circular-shape and elliptical-shape ,etc. A circular printed monopole antenna designed by J. Liang and L. Guo, as shown in Fig 8a[14], possesses a ratio bandwidth of  $S_{11} \leq -10\text{dB}$  exceeding 5.3:1, with the frequency range from 2.27 to 12GHz or above. The UWB printed monopole antenna designed by J. Jung [15], as shown in Fig. 8b, has

a trapezium transition in the monopole patch and a rectangle slot in its ground plane , equivalent to add a matching network between the patch and the ground plane, thereby to broadening the antenna bandwidth. It covers the frequency range 3.1 ~ 11GHz with a mere size of 16 mm×18mm. A printed elliptical monopole antenna designed by C.Y. Huang [16] also uses a rectangular slot in the ground plane to widen the bandwidth. The circular printed monopole antenna with an annulus, as illustrated in Fig. 9, possesses  $S_{11} \leq -10\text{dB}$  from 2.127GHz to 12GHz [17]. All these designs are fed by a microstrip line. In the meantime some printed monopole antennas fed by coplanar waveguides (CPWs) have been developed too, as shown in Fig10 [18, 19]. The ratio bandwidth of aforementioned antennas mostly are about 3 ~ 7:1. Based on the idea to plate the discone antenna, our group has developed a new type of modified printed monopole antennas with super-wide bandwidth, as plotted in Fig 11, which consists of a monopole patch and a trapeziform ground plane with a tapered coplanar waveguide (CPW) feeder in the middle, achieving an impedance bandwidth ratio of exceeding 10:1 [20-23]. To have wider bandwidth, we have changed the rectangular patch to elliptical patch and optimized the dimension, as shown in Fig.11 , whose parameters are:  $a=120\text{mm}$ ,  $b=30\text{mm}$ ,  $t=2.3\text{mm}$ ,  $D_{\min}=9\text{mm}$ ,  $D_{\max}=140\text{mm}$ ,  $H=75\text{mm}$ ,  $G=3.0\text{mm}$   $w_{\text{top}}=1.0\text{mm}$ , and  $w_{\text{bottom}}=2.7\text{mm}$ , with a substrate of thickness  $h=1.524\text{mm}$  and relatively permittivity  $\epsilon_r = 3.48$  [24]. Its tapered CPW transmission line smoothly transforms the input impedance of about  $100\Omega$  at the top point A to  $50\Omega$  of an N-type connector at Point B.

This antenna achieves a measured impedance bandwidth of exceeding 21:1, covering frequency range from 0.41 ~ 8.86GHz, with a good gain and omni-directional radiation performance, as shown in Fig 12, while its area is only about  $0.19\lambda_l \times 0.16\lambda_l$ , where  $\lambda_l$  is the wavelength of the lowest operating frequency. In this figure, the simulated results are obtained by means of CST Microwave Studio software based on the finite integration technique (FIT) method.

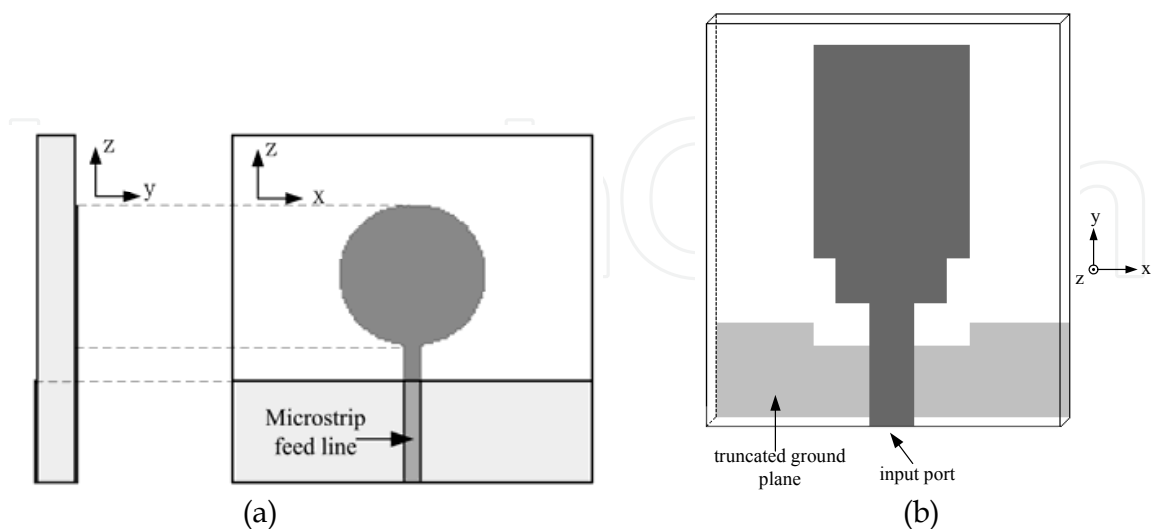

Fig. 8. Microstrip-fed printed monopole antennas [14] [15]

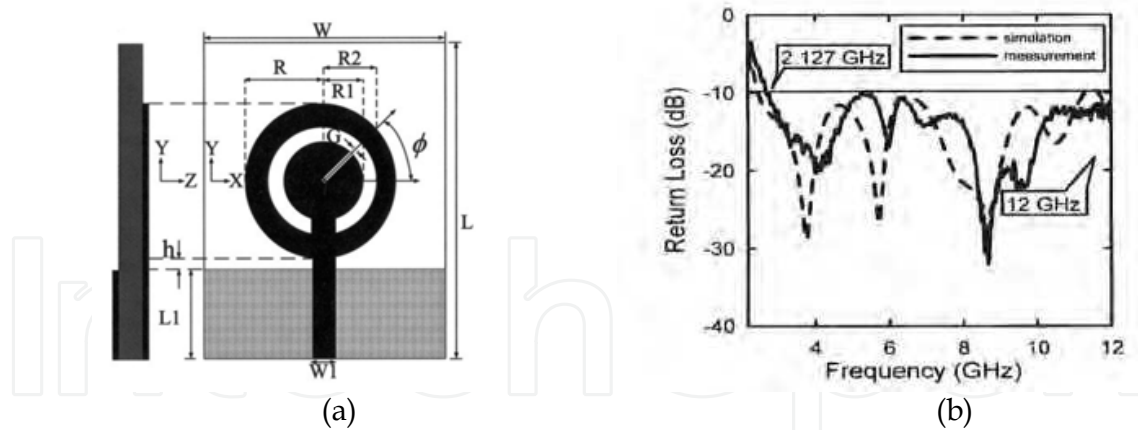

Fig. 9. Printed circular monopole antenna with an annulus<sup>[17]</sup>



Fig. 10. Printed CPW-fed monopole antennas<sup>[18, 19]</sup>

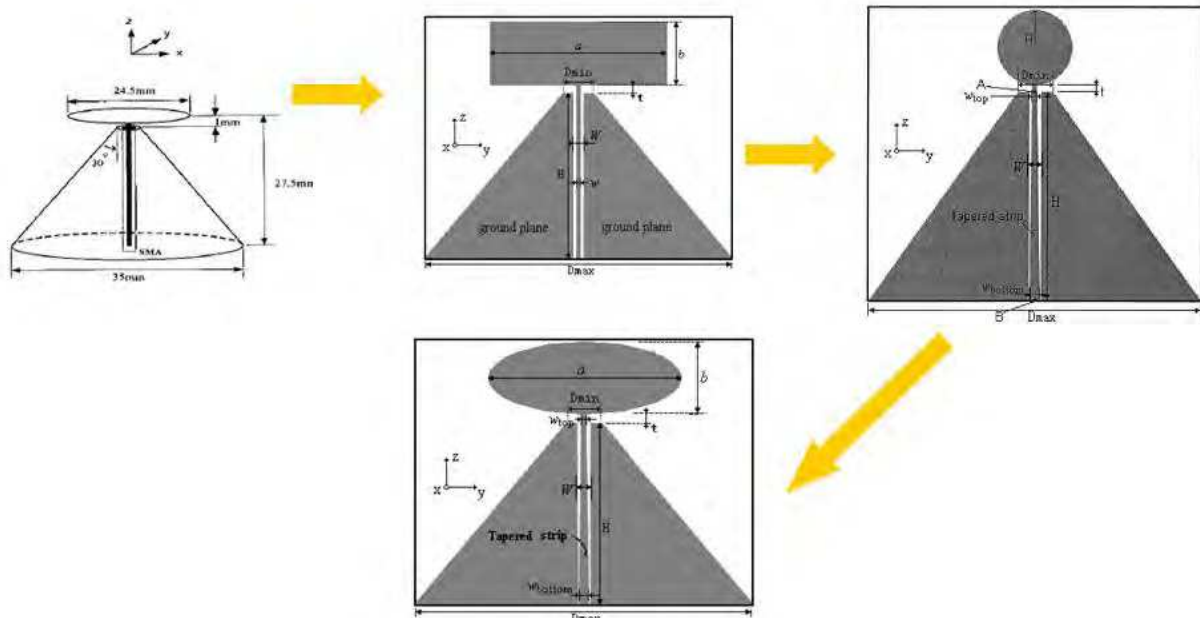
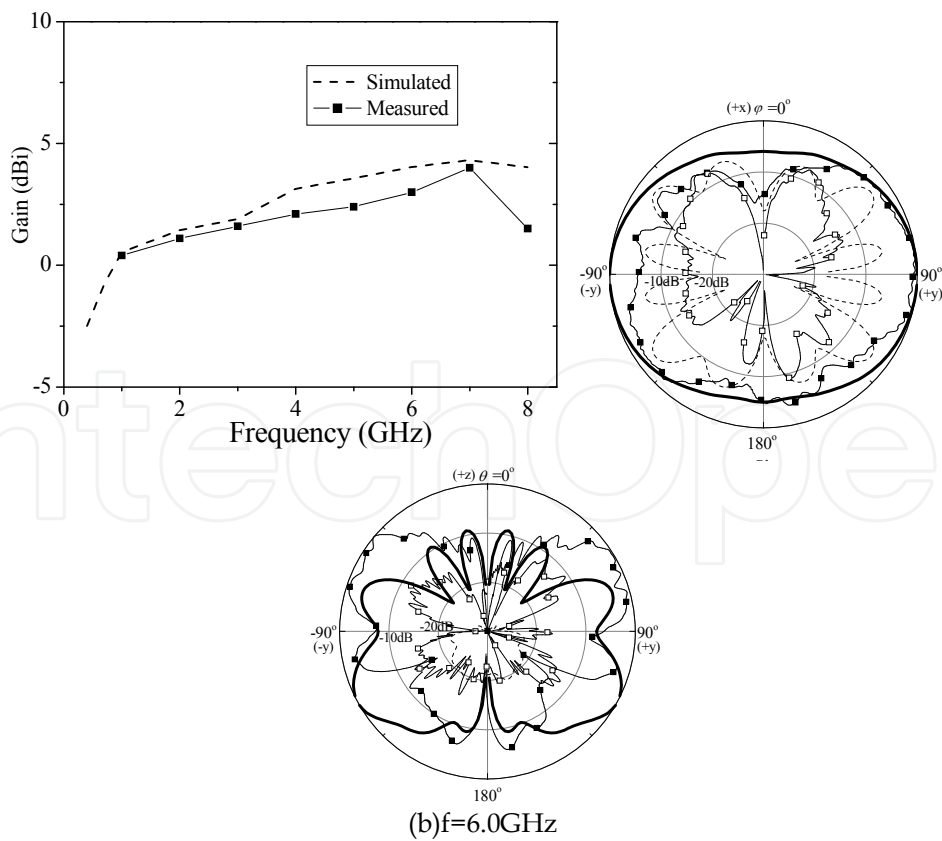
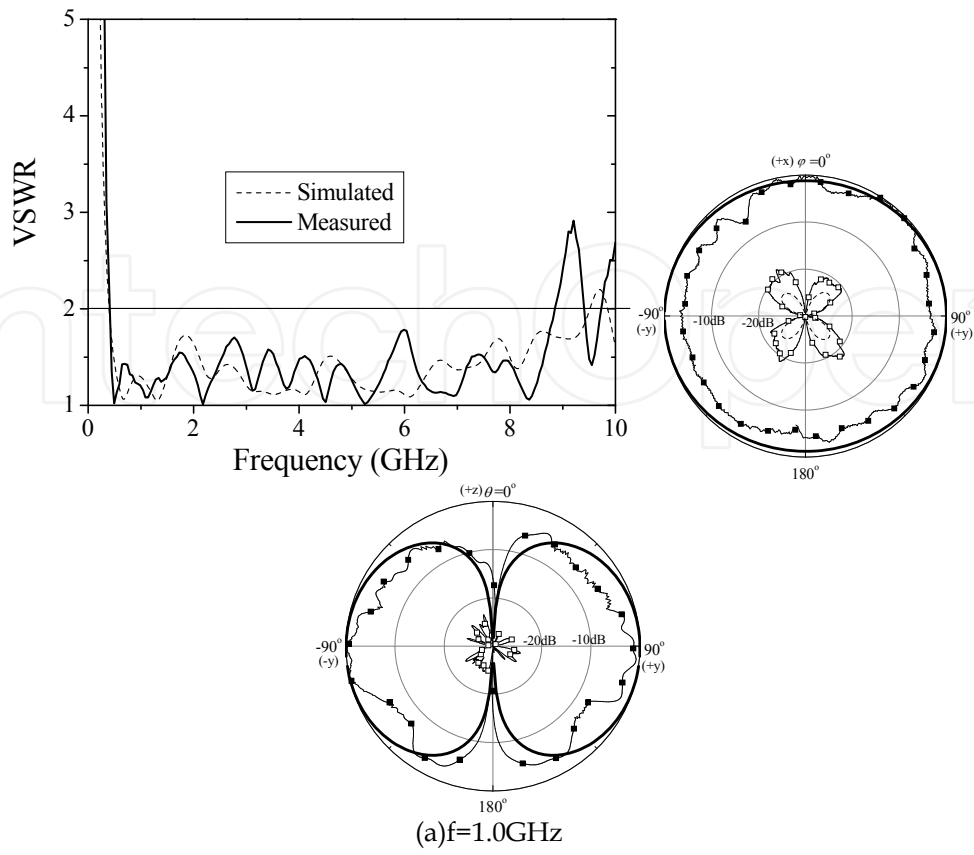

Fig. 11. UWB printed monopole antennas with trapeziform ground plane<sup>[20-24]</sup>.





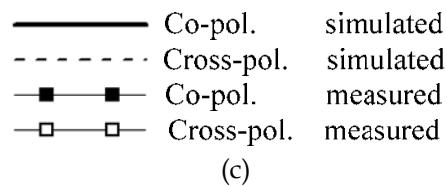

Fig. 12. VSWR , gain and radiation patterns of the Fig.11c antenna with trapeziform ground plane<sup>[24]</sup>

In Table1, the simulated and measured VSWR $\leq$ 2 bandwidths for two elliptical monopoles and other monopoles with rectangular and circular shapes<sup>[22]</sup> <sup>[23]</sup> are listed. Comparing the measured bandwidths of No.1 and No.2, it is seen that by adopting the tapered CPW (No.2), the VSWR $\leq$ 2 bandwidth is enhanced by 10.7/6.3=1.7 times. Comparing the calculated bandwidths of No.3 and No.4, it is shown that using the trapeziform ground plane instead of a rectangular one may broaden the impedance bandwidth to 11.0/7.2=1.5 times; while comparing No.4 with No.6, it is noted that by selecting the elliptical monopole with an optimum major axis  $a$ , the measured impedance bandwidth is enhanced to more than 21:1, *i.e.* almost double. Therefore, the bandwidth broadening of the Fig.11c antenna comes from three improvements: the optimum elliptical monopole shape, a trapeziform ground plane and a tapered CPW feeder.

No	Antenna Configuration	Frequency range of VSWR $\leq$ 2 (GHz)		Ratio bandwidth of VSWR $\leq$ 2	
		Calculated	Measured	Calculated	Measured
1	Rectangular monopole with a 50 $\Omega$ CPW <sup>[22]</sup>	0.64 ~ 3.46	0.59 ~ 3.72	5.4:1	6.3:1
2	Rectangular monopole with a tapered CPW <sup>[22]</sup>	0.83 ~ 8.17	0.76 ~ 8.15	9.8:1	10.7:1
3	Circular monopole with a rectangular ground plane <sup>[23]</sup>	1.3 ~ 9.4	--	7.2:1	--
4	Circular monopole with a trapeziform ground plane <sup>[23]</sup>	0.87 ~ 9.56	0.79 ~ 9.16	11.0:1	11.6:1
5	Elliptical monopole of $a=60\text{mm}$ <sup>[24]</sup>	0.58 ~ 9.54	0.64 ~ 8.94	16.4:1	14.0:1
6	Elliptical monopole of $a=120\text{mm}$ <sup>[24]</sup>	0.4 ~ 9.51	0.41 ~ 8.86	23.8:1	21.6:1

Table 1. Comparison of impedance bandwidths

The current distribution of elliptical monopole antenna is shown in Fig.13. It is noted that, at all frequencies of its operation bandwidth, the surface currents of the monopole patch are mostly concentrated on the bottom periphery of the patch close to the feed, while those on the upper periphery and around the center of the patch are of very low current density. From this observation, a circular hollow was cut out from the elliptical patch to eliminate the region of low current density, resulting in the new design of Fig.13, whose measured VSWR $\leq$ 2 bandwidth is 24.1:1, covering a frequency range from 0.44 to 10.6 GHz <sup>[25]</sup>. Its area is only about  $0.18\lambda_l \times 0.13\lambda_l$ . In order to reduce size, a semi-monopole printed antenna was developed and the VSWR $\leq$ 2 ratio bandwidth of 25.9:1 ( 0.795-20.6 GHz ) was measured <sup>[26]</sup>. However, its cross-polarization radiation is higher.

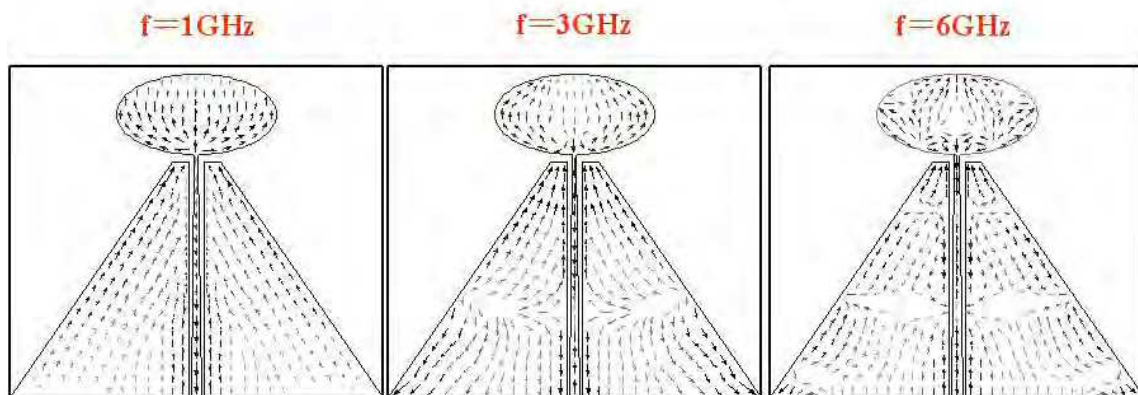

Fig. 13. Current distribution of elliptical monopole antenna

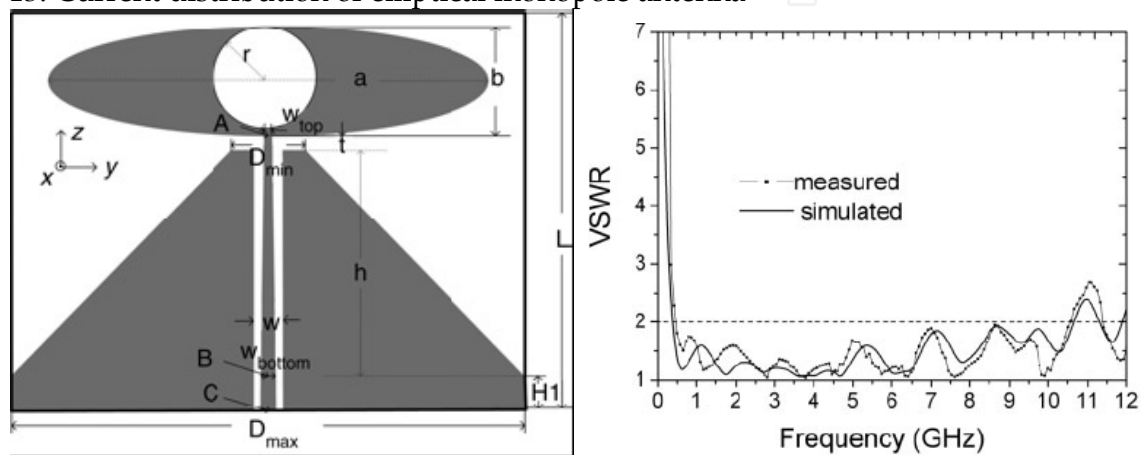

Fig. 14. Hollowed elliptical monopole antenna and its VSWR<sup>[25]</sup>

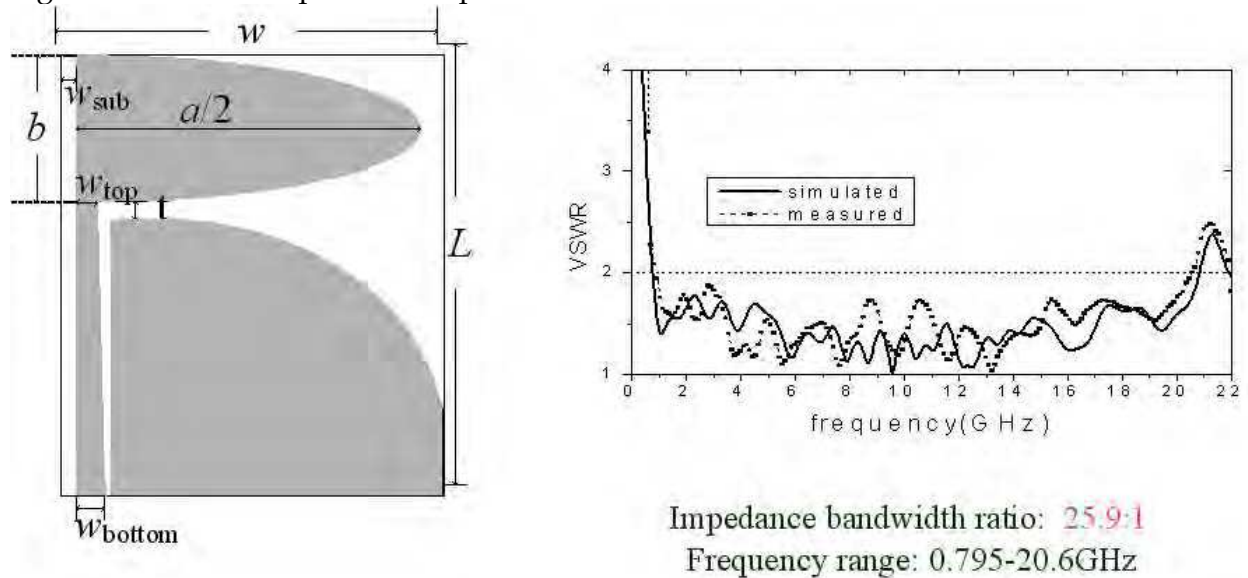

Fig. 15. Hollowed elliptical monopole antenna and its VSWR [26]

#### 4. UWB printed slot antennas

For the integration application of a Vivaldi-like slot antenna, its impedance bandwidth is inherently limited by the microstrip-to-slotline transition. A printed two-side-antipodal

exponential tapered slot antenna proposed by Gazit [27] has resolved the transition problem, though with a relatively higher cross-polarization level. Later, the balanced antipodal Vivaldi tapered slot antenna introduced by J.D.S. Langley[28], as shown in Fig. 16a, restrains the cross-polarization to be less than -17dB, with a ratio bandwidth of 15:1, covering frequencies from 1.3 ~ 20GHz. Fig.16b is a dual tapered UWB design using CPW feeding[29].

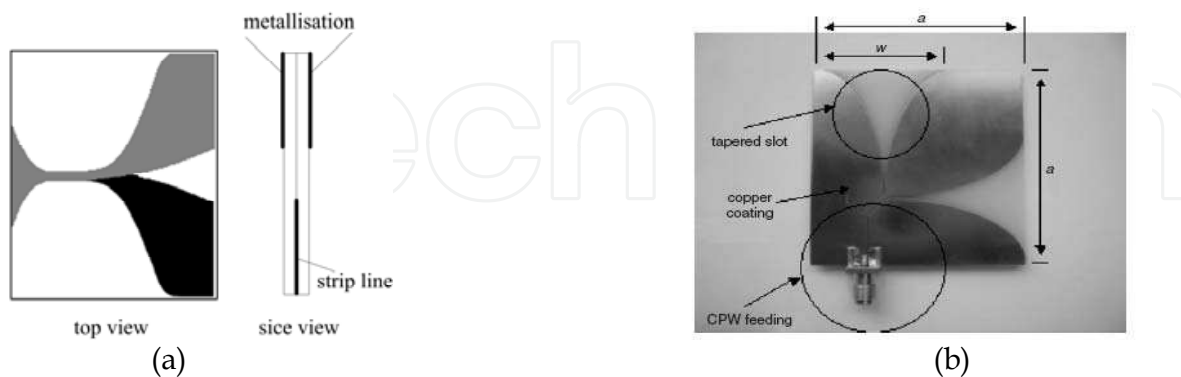

Fig. 16. Printed tapered slot antennas[28] [29]

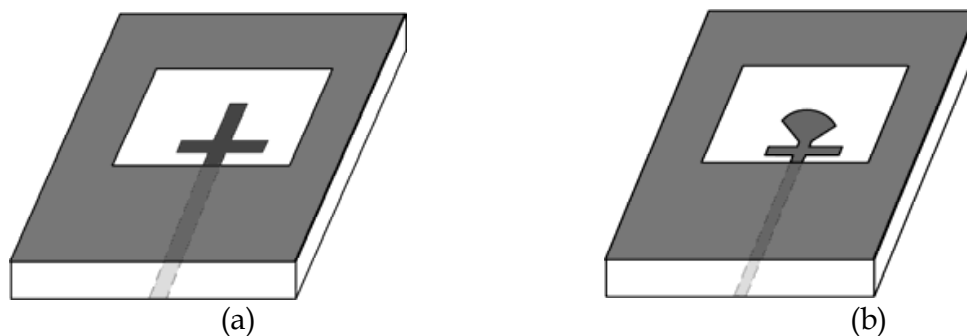

Fig. 17. Microstrip-fed rectangular slot antennas [30] [31]

In recent years, many researches have been engaged in the printed wide-slot antenna and have realized the ultra-wideband property through a combination of changing the slot shape and using different feeding structures. Fig.17 shows two kinds of printed wide-slot antennas with different feeding structures. In Fig.17a the wide-slot antenna is fed by a cross-shaped feeding with a cross-shaped stub at the end instead of the common opened microstrip feeder, which is equivalent to introducing a resonance circuit and hence resulting in an impedance bandwidth of 98% [30]. The slot antenna fed by a fan-shaped stub together with a strip line proposed by our lab, as shown in Fig 17b, has achieved a bandwidth of 114% by optimizing the length of the stub and the size of the fan-shape [31]. Fig.18 shows two printed slot antennas using U-shaped microstrip feedings. Fig. 18a adds a rectangular patch in the middle of the rectangular slot and connecting with the ground plane to achieve a measured impedance bandwidth of 111% [32]. In Fig.18b, by adding a rectangular copper sheet in one side of the microstrip to adjust the port impedance of the antenna, its impedance bandwidth extends to 135.7%, covering frequencies 2.3 ~ 12GHz[33].

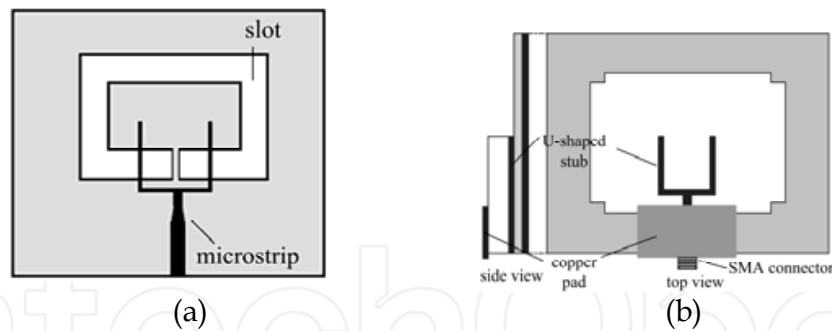

Fig. 18. U-shaped microstrip fed printed slot antennas [32] [33]

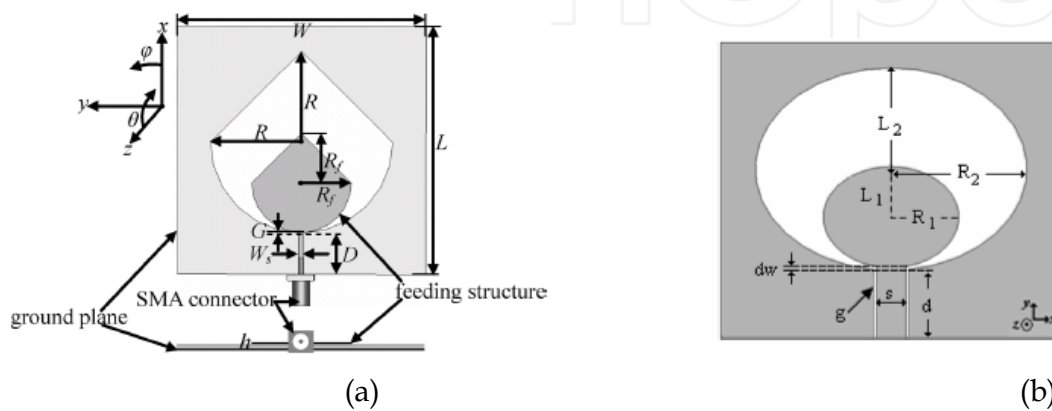

Fig. 19. Printed slot antennas with shaped-slots [34] [36]

The printed wide-slot antennas have been designed to use various slot shapes. In Fig.19a, the design of PICA (Planar Inverted Cone Antenna) achieves a  $VSWR \leq 2$  ratio bandwidth of 13:1 [34]. The CPW-fed printed wide-slot antennas also have been designed to use various shapes of the guide strip terminal of its CPW feeder to excite the slot, and accordingly obtain the broadening of its impedance bandwidth. A design achieves an impedance bandwidth about 114%, whose CPW terminal is a rectangular patch with a concave gap [35]. The elliptical slot antenna with an elliptical patch as its feed, as shown in Fig.19b, widens the impedance bandwidth to 175%, covering frequencies from 1.3GHz to 20GHz or above with a ratio bandwidth about 15:1 [36].

Another type of printed slot antenna is the printed bow-tie slot antenna, as shown in Fig.20, which has the virtue of simple configuration, wider bandwidth, lower cross-polarization level and higher gain.

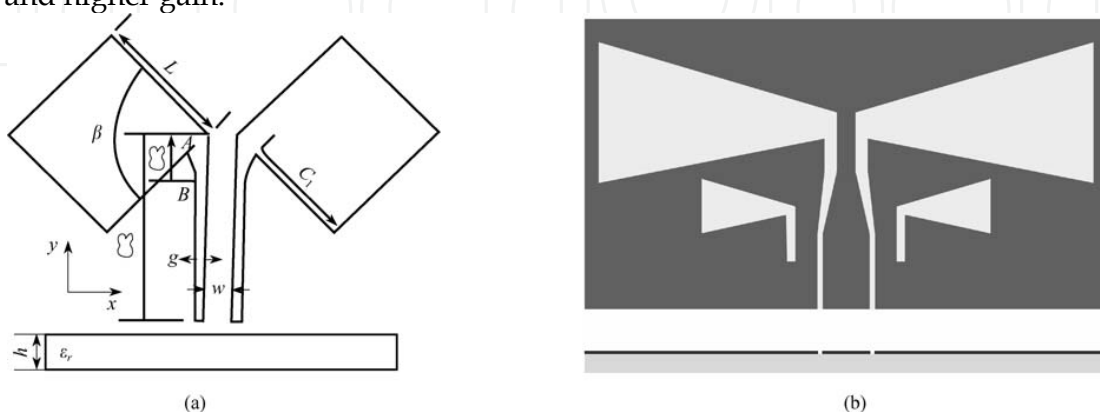

Fig. 20. CPW-fed bow-tie printed slot antennas [37] [38]

Fig.20a was designed at our lab, which widens the impedance bandwidth by using a lineally tapered slot at the joint of the coplanar waveguide and the bow-tie slot [37]. In Fig.20b a small bow-tie slot is added under the bow-tie slot antenna, and excited by the coupling of the coplanar waveguide. In addition, a tapered coplanar waveguide feeder is applied, so that the antenna achieves an impedance bandwidth of 123% [38].

A comparison of the main performances of several UWB planar antennas is listed in Table 2. It is noted that the UWB printed monopole antennas have dimensions close to those of UWB plate monopole antennas, whereas without a perpendicular metal ground plane. For example, a printed elliptical monopole antenna with a trapezium ground plane has the dimension of only  $0.19 \times 0.16 \lambda_l^2$ , where  $\lambda_l$  is the wavelength of the lowest operating frequency, and an impedance bandwidth of 21.6:1. UWB printed slot antennas possess a relatively higher gain compared with the other two UWB antennas, and a relative larger size.

No.	Antenna type	Bandwidth(GHz) (VSWR $\leq$ 2)	Ratio bandwidth (VSWR $\leq$ 2)	gain (dBi)	size ( $\lambda_l^2$ )
1	Trapezoidal metal plate monopole [ 8]	1.07 ~ 12.2	11.4:1	0.5 ~ 4.5	0.89×0.89*
2	Planar inverted cone antenna [9]	1 ~ 10	10:1	0.3 ~ 8.6	0.25×0.25
3	Leaf-shaped plate monopole [10]	1.3 ~ 29.7	22.8:1	3 ~ 5	0.35×0.35
4	Circular monopole with a trapeziform ground plane [21]	0.79 ~ 9.16	11.6:1	0.8 ~ 4.1	0.37×0.24
5	Rectangular monopole with a trapeziform ground plane [22]	1.76 ~ 8.17	10.7:1	0.65 ~ 4.2	0.35×0.30
6	Elliptical monopole with a trapeziform ground plane [24]	0.41 ~ 8.86	21.6:1	0.4 ~ 4	0.19×0.16
7	Tapered slot antenna [29]	1.3 ~ 20	15.4:1	3.2~ 9	0.43×0.32
8	printed Elliptical slot antenna [36]	1.3 ~ 20	15.4:1	-----	0.39×0.39

\* Ground plane dimension

Table 2. Comparison of UWB planar antennas

The UWB printed monopoles are more suitable for smaller portable devices where volume constraint is a significant factor. In such devices a main requirement for antennas is the capability to transmit a pulse with minimum distortion and thus preserve the shape of the pulse. Three printed monopole antennas with typical shapes and sizes have been evaluated in the radio channel in the context of frequency and time domain performances [39]. The antenna geometries used are shown in Fig.21, where (A) is a rectangular planar monopole of area 75 mm×40 mm with FR4 substrate of 1.52 mm thick, (B) a smaller antenna with both radiator and ground plane spline-shaped of area 30 mm×40 mm on a 0.76 mm thick RO 4350 substrate, and (C) an even smaller spline antenna on 0.4 mm FR4 of area 30mm×30mm. The measured S11 for each antenna is shown in Fig.22. Ant. A exhibits a 10 dB return loss from 1.59 to 6.9 GHz, and Ant. B offers a 14 dB return loss over the bandwidth 3.1-10.6 GHz,

while Ant.C offers 6 dB from 2.31-6.7 GHz.

To quantify the distortion of each antenna, a pair of each antenna shape was set up to transmit and receive a pulse. The correlation of the received pulse with the input one was expressed by the fidelity factor, which is a measure of the capability of an antenna to preserve a pulse shape, and is written as [40]

$$F = \max_{\tau} \int_{-\infty}^{\infty} L[\hat{f}(t)] \hat{r}(t + \tau) dt$$

Where the input  $\hat{f}(t)$  and the output  $\hat{r}(t)$  have been normalized to have unit energy, and  $L[\hat{f}(t)]$  is the idealized system function, while the delay  $\tau$  is varied to maximize the integral term.

Each pair of antennas was placed in different orientations, face-to-face, back-to-back, face-back, and so on. The pulse used was a raised cosine pulse of 0.4 GHz bandwidth centered at 4 GHz. The fidelity factor for each combination is listed in Table 3. It is seen that Ant. B generally achieves the best fidelity in any configuration. The analysis shows a general advantage for the spline based antenna geometries over the rectangular monopole shape. Fig.23 shows the input and normalized measured output pulse for Ant. B in the back-to-back configuration. It is demonstrated that the shape of the pulse is preserved very well by the antennas.

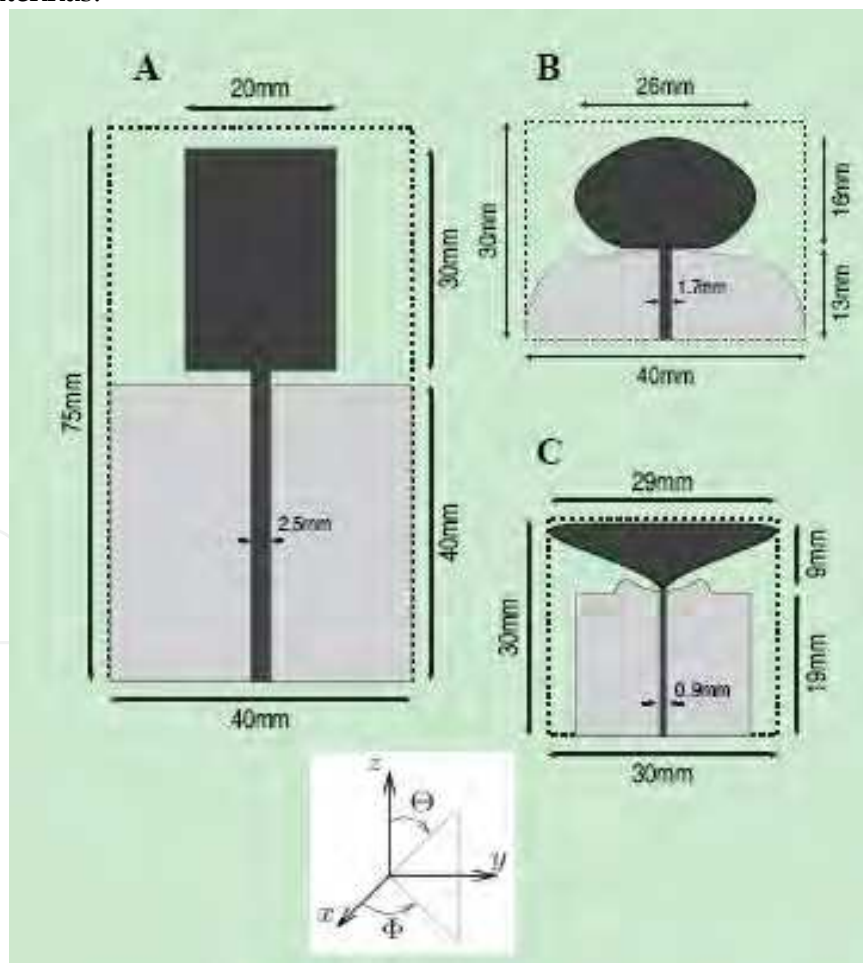

Fig. 21. Geometries and dimensions of 3 test printed monopole antennas [39]

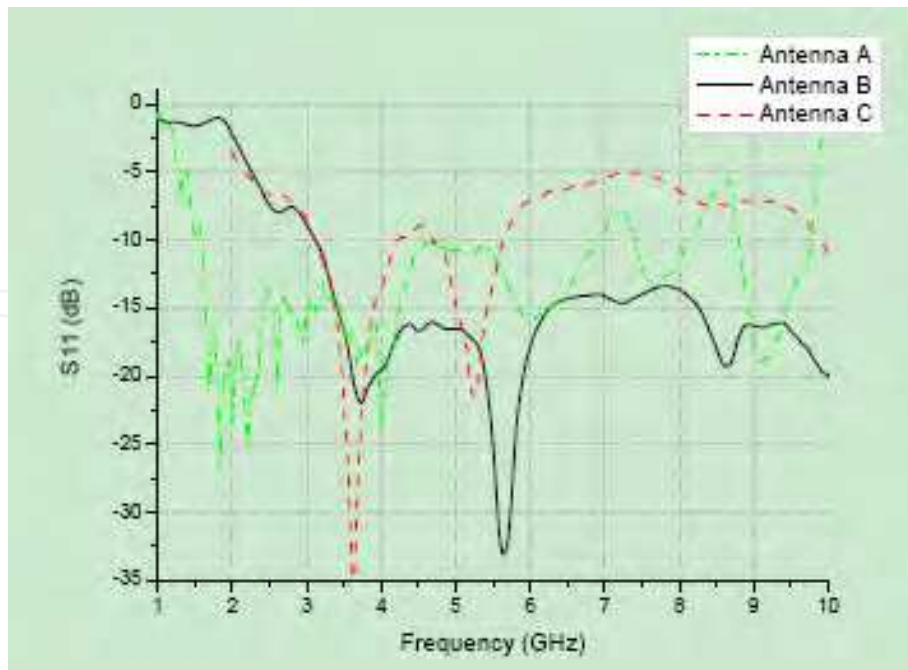

Fig. 22. Measured S11 for 3 test antennas [39]

Table 3 [39]

FIDELITY FACTOR OF THE THREE ANTENNAS IN DIFFERENT ORIENTATIONS (%)			
	A	B	C
face-to-face	94.9	96.7	93.9
back-to-back	95.2	99.4	95.4
face-to-back	95.9	98.8	96.7
face-to-side	92.9	96.3	96.2
back-to-side	94.2	99.1	95.8
side-to-side	95.3	98.1	92.0

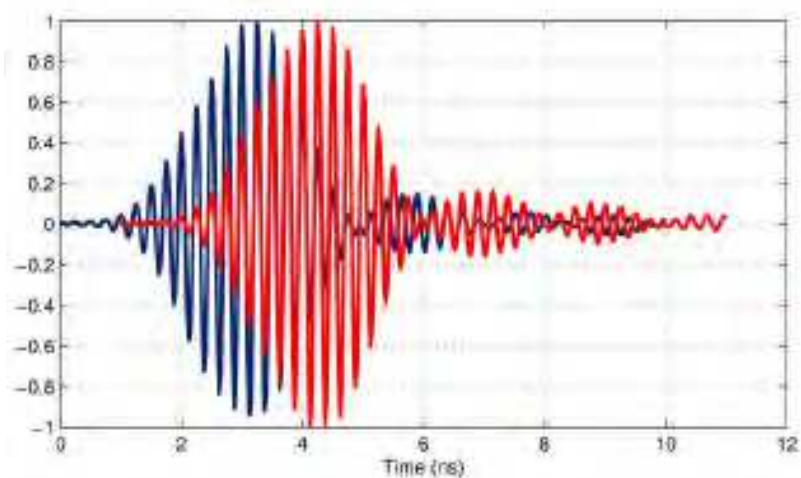

Fig. 23. Input and normalized measured output pulses for Ant. B [39]

## 5. UWB band-notched planar antennas

To avoid the interference between the UWB system and the wireless local area network (WLAN) 802.11a system with 5.15 to 5.825 GHz frequency band, a band-notch filter in the UWB system is needed. To avoid adding filters and possible interference with existing WLAN systems, UWB antennas with band-notched characteristics have been developed. The sail-boat antenna, as shown in Fig 24a, achieves the UWB property by using an inverse taper planar patch, and forms the band-notch function near the 5GHz frequency by cutting two slots in the patch, which possesses a bandwidth of 3~11GHz for  $VSWR \leq 2$  except frequencies neighboring 5.2GHz<sup>[41]</sup>. A UWB circular disc monopole antenna designed by our lab, as shown in Fig. 24b, provides the band notched function by inserting an arched slot in the circular monopole patch<sup>[42]</sup>. The antenna of Fig. 25 achieves the wide bandwidth property by using a step-shape taper in the pear-shape monopole patch, then forming the band-notch function by introducing two parasitic printed patches<sup>[43]</sup>. The CPW-fed antenna of Fig. 26 obtains the UWB performance also by means of the step-shape taper in the monopole patch, while its band-notch function is realized by introducing two folded-striplines on the backside of the substrate<sup>[44]</sup>.

In Fig.27a,the configuration of a novel band-notch printed antenna is illustrated<sup>[45]</sup>, where the double-feed technique combined with the tapered impedance transformer is used to obtain a wide impedance bandwidth, and an inverted U-shaped slot embedded in the microstrip feeder is adopted to realize the band-notch characteristic, which does not worsen antenna radiation performance. As shown in Fig.27b, the measured VSWR with slot exhibits a notched-band of 5.15-6.02 GHz for  $VSWR > 2$ , while the wideband performance from 3.05 to 10.84 GHz is maintained. Fig.27c shows the simulated omnidirectional performance in the entire operating bandwidth, where the omnidirectional fluctuation is denoted by the max-radiation level minus the min-radiation level in the H-plane. It is noted that the fluctuation is below 4.8 dB in the frequency range of 3.1-10 GHz, and that the cross-polarization is below -19dB in the whole bandwidth. The measured antenna gain is about 2.6-4.5 dBi in the operating bandwidth while a sharp decreased gain is about -5.5dBi in the notched-band of 5-6 GHz.

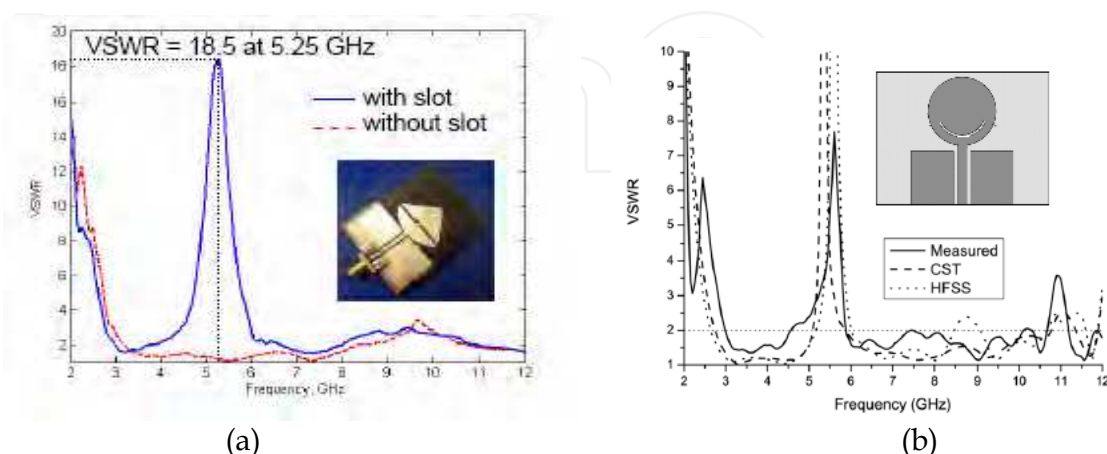

Fig. 24. UWB printed monopole antennas with band-notch function<sup>[41]</sup> [42]



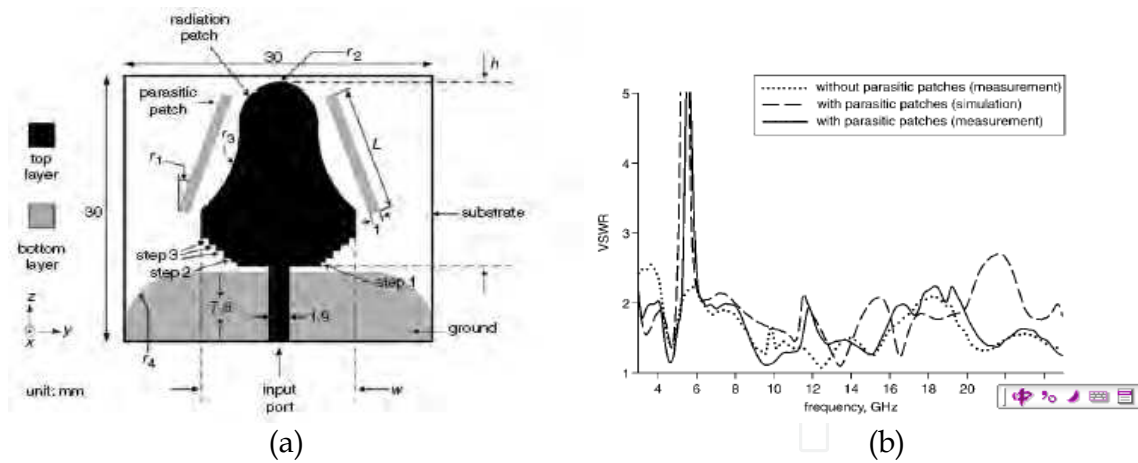

Fig. 25. UWB printed band-notch antenna with two parasitic patches<sup>[43]</sup>

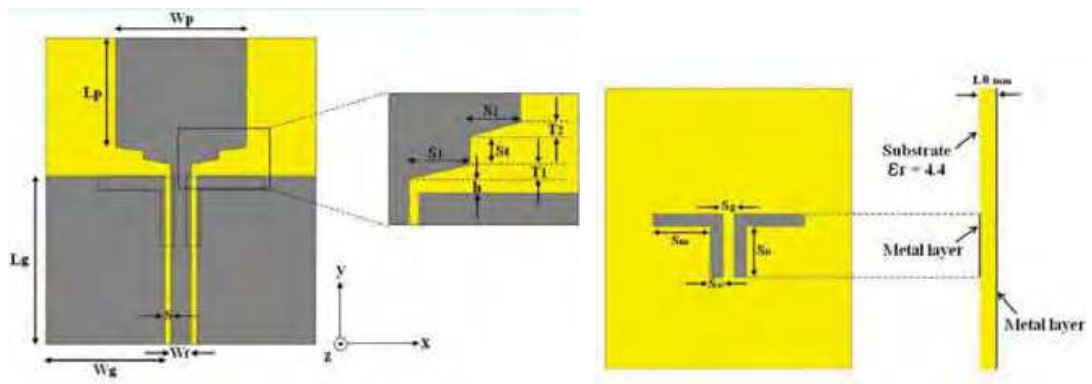
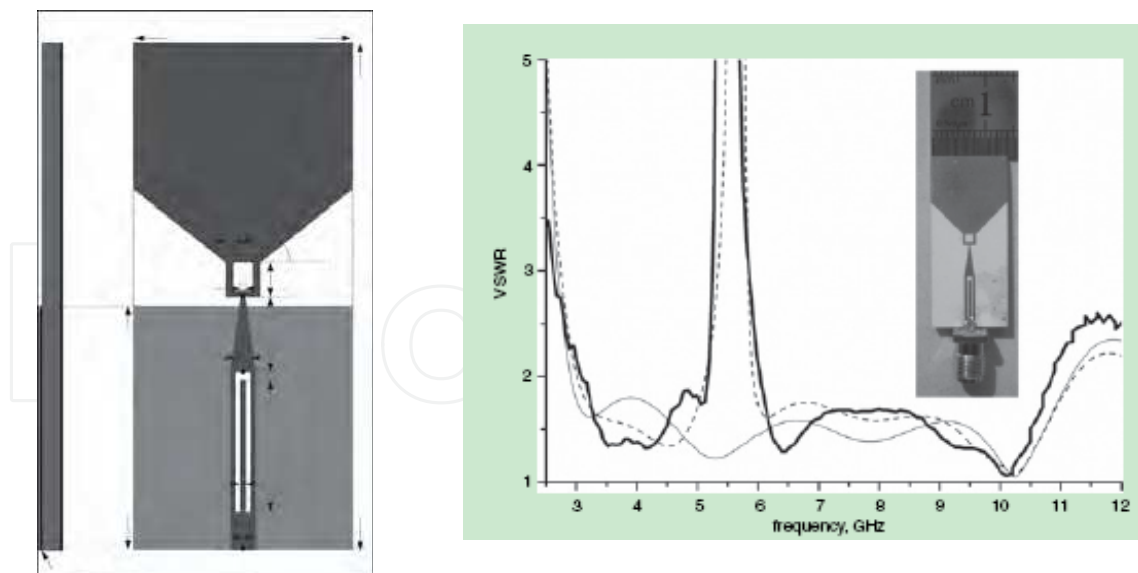

Fig. 26. UWB printed band-notch antenna with two folded-striplines<sup>[44]</sup>



- Simulated without slot
- - - Simulated with slot
- Measured with slot

(a)

(b)

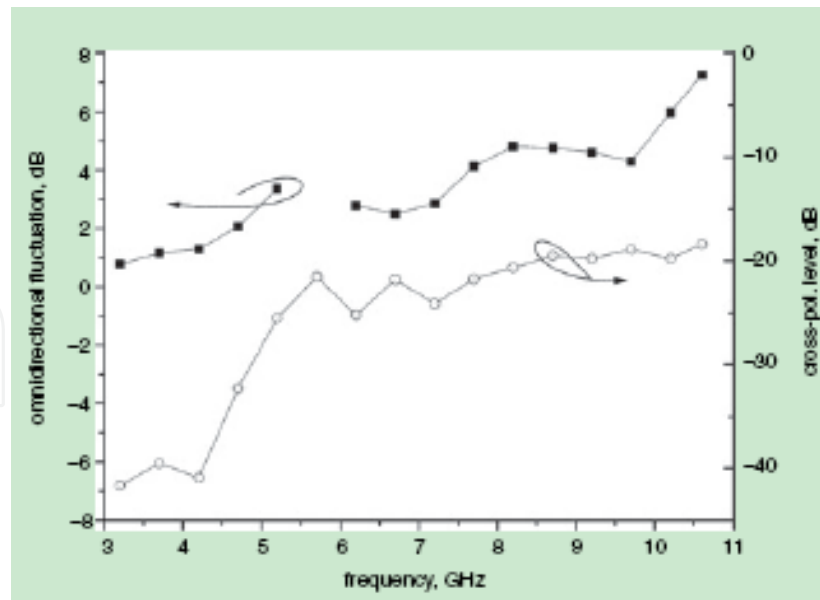

(c)

Fig. 27. UWB printed band-notch antenna with an inverted U-shaped slot in the feeder<sup>[45]</sup>

## 6. Conclusion

The recent progress in the development of UWB planar antenna technology has been reviewed. Some types of UWB metal-plate monopole antennas, UWB printed monopole antennas and UWB printed slot antennas are presented. The comparison results indicate that the UWB printed monopole antennas can realize relatively smaller dimensions, and that the UWB printed slot antennas can achieve relatively higher gain. Finally, some realization manners of the band-notch function of UWB printed monopole antennas have been introduced. Along with the wide application of the UWB technology, compact UWB antennas will achieve further development.

## 7. Acknowledgements

This work was supported by the National Natural Science Foundation of China (Grant No. 60571053), and the Shanghai Leading Academic Discipline Project (No.S30108).

## 8. References

- [1]Z.N. Chen, et al. Considerations for source pulses and antennas in UWB ratio systems [J]. IEEE Trans. Antennas propag., 2004, 52(7): 1739-1748.
- [2]H. Schantz. A brief history of UWB antennas[J]. Aerospace and Electronic Systems Magazine, 2004, 19(4): 22-26.
- [3]V. Rumsey. Frequency Independent Antennas [M]. Academic Press. New York, 1966.
- [4]P.J.Gibson, The Vivaldi aerial[C]. 9<sup>th</sup> European Microwave Conference, Brighton, UK, 1979:101-105.
- [5]S. S. Zhong,X. R. Yan and X. L. Liang, UWB planar antennas technology [J] . Frontiers of Electric and Electronic Engineering in China, 2008, 3(2):136-144.

- [6]G. Dubost and S. Zisler. Antennas a Large Bande [M]. New York: Masson, 1976:128-129.
- [7]N.-P. Agrawal, G. Kumar and K.-P. Ray. Wide-band planar monopole antennas [J]. IEEE Trans. Antennas Propag., 1998, 46(2):94-295.
- [8]J.A. Evans and M.J. Ammann. Planar trapezoidal and pentagonal monopoles with impedance bandwidths in excess of 10:1 [C]. IEEE Antennas Propagat. Symp., Orlando, FL, 1999, vol.3:1558-1561.
- [9]S.Y. Suh, W.L. Stutaman and W.A. Davis. A new ultrawideband printed monopole antenna: the Planar Inveted Cone Antenna (PICA) [J]. IEEE Trans. Antennas Propagat., 2004, 52(5):1361-1365.
- [10]X.F. Bai, S.S. Zhong and X.L. Liang. Leaf-shaped monopole antenna with extremely wide bandwidth [J]. Microwave Opt. Tech. Lett., 2006, 48(7): 1247-1250.
- [11]P. V. Anob, K. P. Ray, and G. Kumar. Wideband orthogonal square monopole antennas with semi-circular base[C]. IEEE Antennas Propagat. Symp., Boston, 2001, vol.3:294-297.
- [12]M.J. Ammann and Z.N. Chen. A wide-band shorted planar monopole with bevel [J]. IEEE Trans. Antennas Propagat., 2004, 51(4): 901-903.
- [13]E. Antonino-Daviu, M. Cabedo-Fabres, *et al.* Wideband double-fed planar monopole antennas [J]. Electron. Lett., 2003, 39(23):1635-1636.
- [14]J. Liang and L. Guo. CPW-fed circular disc monopole antenna for UWB applications [C]. IEEE International Workshop on Antenna Technology: Small Antennas and Novel Metamaterials. Singapore, 2005:505-508.
- [15]J. H. Jung, W. Y. Choi and J.H. Choi. A small wideband microstrip-fed monopole antenna [J]. IEEE Microwave and Wireless Component Letters, 2005, 15(10): 703-705.
- [16]C.Y. Huang and W.C. Hsia. Planar elliptical antenna for ultra-wideband communications [J]. Electron. ett., 2005, 41(6):296-297.
- [17]Y.C. Kang, C.N. Chiu and S.M. Deng. A new planar circular disc-and-ring monopole antenna for UMTS/UWB dual-network applications [J]. Microwave and Opt. Tech. Lett., 2006, 48(12):2396-2399.
- [18]N. Fortino, G. Kossivas, J.Y. Dauvignac and R. Staraj. Novel antennas for ultra-wideband communications [J]. Microwave and Opt. Tech. Lett., 2004, 41(3):166-169.
- [19]W.S. Chen, S.C. Wu and K.N. Yang. A study of the printed heart monopole antenna for IEEE 802.16a/UWB applications [C]. IEEE Antennas Propagat. Symp., Albuquerque, Mew Mexico, 2006:1685-1688.
- [21]X.-L. Liang, S.-S. Zhong, W. Wang and F.-W. Yao. Printed annular monopole antenna for ultra-wideband applications [J]. Electron. Lett., 2006, 42(2):71-72
- [22]S.-S. Zhong, X.-L. Liang, F.-W. Yao, W.Wang and X.-F. Bai, Ultra-wideband printed antennas for communication applications [J]. Journal of Shanghai University (English Edition), 2006, 10(1):48-52.
- [23]X.-L. Liang, S.-S. Zhong and W. Wang, Tapered CPW-fed printed monopole antenna [J]. Microwave and Opt. Tech. Lett., 2006, 48(7):1242-1244.
- [24]X.-L. Liang, S.-S. Zhong and W. Wang, UWB printed circular monopole antenna [J]. Microwave and Opt. Tech. Lett., 2006, 48(8):1532-1534.
- [25]S.-S. Zhong, X.-L. Liang and W. Wang, Compact elliptical monopole antenna with impedance bandwidth in excess of 21:1 [J]. IEEE Trans. Antennas and Propagation 2007, 55(11) Part 1 :3082 - 3085

- [26]X.-R. Yan, S.-S. Zhong and G.-Y. Wang, Compact printed monopole antenna with 24:1 impedance bandwidth[J]. *Electron. Lett.* 2008,44(2):73-75.
- [27]S.-S. Zhong and X.-R. Yan, A semi-monopole printed antenna with extremely wide bandwidth[C].*IEEE International Symposium on Antennas and Propagation, San Diego, CA, July 2008.*
- [28]E. Gazit. Improved design of the Vivaldi antenna [J]. *Proc. Inst. Elect. Eng.*, 1988, 135(2):89-92.
- [29]J.D.S. Langley, P.S. Hall, and P. Newham. Novel ultra-wide-bandwidth Vivaldi antenna and low cross-polarisation [J]. *Electron. Lett.*, 1993, 29(23): 2004-2005.
- [30]Y. Kim and D.-H. Kwon. CPW-fed right-angled dual tapered notch antenna for ultra-wideband communication [J]. *Electron. Lett.*, 2005, 41(12):674-675.
- [31]Y.W. Jang. Broadband cross-shaped microstrip-fed slot antenna [J]. *Electron. Lett.*, 2000, 36(25):2056-2057
- [32]F.W. Yao, S.S. Zhong and X.L. Liang. Wideband slot antenna with a novel microstrip feed [J]. *Microwave Opt. Tech. Lett.*, 2005, 46(3): 275-278.
- [33]S. Sadat and M. Fardis. A compact microstrip square-ring slot antenna for UWB applications [C]. *IEEE Antennas Propagat. Symp.*, Albuquerque, New Mexico, 2006: 4629-4633.
- [34]D.C. Chang , J.C. Liu and M.Y. Liu. Improved U-shaped stub rectangular slot antenna with tuning pad for UWB applications [J]. *Electron. Lett.*, 2005, 41(20):1095-1097.
- [35]S. Cheng, P. Halbjorner and A. Rydberg, Printed slot planar inverted cone antenna for ultra-wideband applications [J]. *IEEE Antennas and Wireless Propagat. Lett.*, 2008, Vol.7:18-21.
- [36]S.H. Hsu and K. Chang. Ultra-thin CPW-fed rectangular slot antenna for UWB applications [C]. *IEEE Antennas Propagat. Symp.*, Albuquerque, New Mexico, 2006: 2587-2590.
- [37]S.A. Evangelos and A.Z. Anastopoulos, *et al.* Circular and elliptical CPW-Fed slot and microstrip-fed antennas for ultrawideband applications [J]. *IEEE Antennas and Wireless Propagat. Lett.*, 2006, vol.5: 294-297.
- [38]J.W. Niu and S.S. Zhong. A CPW-fed broadband slot antenna with linear taper [J]. *Microwave and Opt. Tech. Lett.*, 2004, 41(3): 218-221.
- [39]E.S. Angelopoulos, A.Z. Anastopoulos, *et al.*, A modified bow-tie slot antenna fed by a CPW-to-CPW transition loaded with inductively coupled slots for ultra-wideband applications [C]. *IEEE International Workshop on Antenna Technology: Small Antennas and Novel Metamaterials, Singapore, 2005: 513-516*
- [40]M. J. Ammann, A. Dumoulin, M. John and P. McEvoy, Time-domain performance of printed UWB Antennas[C]. *3<sup>rd</sup> European Conference on Antennas and Propagation, Berlin Germany, March 2009:3766-3769.*
- [41]D. Lamensdorf and L. Susman, Baseband-pulse-antenna techniques[J]. *IEEE Antennas Propag. Mag.*, Feb. 1994, 36(1): 20-30.
- [42]S.Y. Suh, Stutzman, W.L. Davis, *et al.* A UWB Antenna with a Stop-band Notch in the 5-GHz WLAN band[C]. *Wireless Communications and Applied Computational Electromagnetics*, 2005:203 - 207
- [43]X.-A. Qu, S.-S. Zhong and W. Wang. Study of the band-notch function for a UWB circular disc monopole antenna[J]. *Microwave and Opt. Tech. Lett.*, 2006, 48(8):1667-1670

- [44]K.-H. Kim, Y.-J. Cho, S.-H. Hwang and S.-O. Park. Band-notched UWB planar monopole antenna with two parasitic patches [J]. Electron. Lett., 2005, 41(14):783-785.
- [45]S.-H. Lee, J.-W. Baik and Y.-S. Kima, Coplanar waveguide fed monopole ultra-wideband antenna having band-notched frequency function by two folded-striplines[J]., Microwave and optical Tech.Lett.,Nov.2007, 49(11):2747-2750.
- [46]L.-N. Zhang, S.-S. Zhong, X.-L. Liang and C.-Z. Du, Compact omnidirectional band-notch ultra-wideband antenna[J]. Electron. Lett., June 2009, 45(13)

IntechOpen

IntechOpen



**Microwave and Millimeter Wave Technologies Modern UWB antennas and equipment**

Edited by Igor Mini

ISBN 978-953-7619-67-1

Hard cover, 488 pages

**Publisher** InTech

**Published online** 01, March, 2010

**Published in print edition** March, 2010

**How to reference**

In order to correctly reference this scholarly work, feel free to copy and paste the following:

Shun-Shi Zhong (2010). UWB and SWB Planar Antenna Technology, Microwave and Millimeter Wave Technologies Modern UWB antennas and equipment, Igor Mini (Ed.), ISBN: 978-953-7619-67-1, InTech, Available from: <http://www.intechopen.com/books/microwave-and-millimeter-wave-technologies-modern-uwband-antennas-and-equipment/uwb-and-swb-planar-antenna-technology>

**INTECH**

open science | open minds

**InTech Europe**

University Campus STeP Ri  
Slavka Krautzeka 83/A  
51000 Rijeka, Croatia  
Phone: +385 (51) 770 447  
Fax: +385 (51) 686 166  
[www.intechopen.com](http://www.intechopen.com)

**InTech China**

Unit 405, Office Block, Hotel Equatorial Shanghai  
No.65, Yan An Road (West), Shanghai, 200040, China  
中国上海市延安西路65号上海国际贵都大饭店办公楼405单元  
Phone: +86-21-62489820  
Fax: +86-21-62489821

intechopen

© 2010 The Author(s). Licensee IntechOpen. This chapter is distributed under the terms of the [Creative Commons Attribution-NonCommercial-ShareAlike-3.0 License](#), which permits use, distribution and reproduction for non-commercial purposes, provided the original is properly cited and derivative works building on this content are distributed under the same license.

IntechOpen

IntechOpen