

We are IntechOpen, the world's leading publisher of Open Access books Built by scientists, for scientists

4,800

Open access books available

122,000

International authors and editors

135M

Downloads

Our authors are among the

154

Countries delivered to

TOP 1%

most cited scientists

12.2%

Contributors from top 500 universities



WEB OF SCIENCE™

Selection of our books indexed in the Book Citation Index
in Web of Science™ Core Collection (BKCI)

Interested in publishing with us?
Contact book.department@intechopen.com

Numbers displayed above are based on latest data collected.

For more information visit www.intechopen.com



Optimal Coordination and Penetration of Distributed Generation with Multi Shunt FACTS Compensators Using GA/Fuzzy Rules

Belkacem Mahdad *, Tarek Bouktir ** and Kamel Srairi *

*Department of Electrical Engineering, Biskra University

**Department of Electrical Engineering, Oum Elbouaghi University
ALGERIA

1. Introduction

In an open electricity market, every consumer will be able to buy his own electricity from any source desired with the result that the unplanned power exchanges are increasing. In order to cope with these kind of problems and increase usable power distribution capacity, distribution generation technology (DG) and Flexible AC transmission systems (FACTS) where developed and introduced to the market.

Optimal placement and sizing of distribution generation is a well-researched subject which in recent years interests many expert engineers. Efficient placement and sizing of distribution generation (DG) in practical networks can result in minimizing operational costs, environmental protection, improved voltage regulation, power factor correction, and power loss reduction (Méndez et al., 2006). DG is defined as any source of electrical energy of limited size interconnected to the distribution system. DG technologies include photovoltaic systems, wind turbines, fuel cells, small micro-sized turbines, sterling-engine based generators and internal combustion engine-generators (Vovos et al., 2007). In practical installation and integration of DG in power system with consideration of FACTS devices, there are five common requirements as follows (Mahdad et al., 2007):

- ▶ What Kinds of DG and FACTS devices should be installed?
- ▶ Where in the system it should be placed?
- ▶ How to estimate economically the number, optimal size of DG and FACTS to be installed in a practical network?
- ▶ How to coordinate dynamically the interaction between multiple DG, FACTS devices and the network to better exploit the DG and FACTS devices to improve the index power quality?
- ▶ How to review and adjust the system protection devices to assure service continuity and keep the index power quality at the margin security limits?

The global optimization techniques known as genetic algorithms (GA), simulated annealing (SA), tabu search (TS), and evolutionary programming (EP), which are the forms of probabilistic heuristic algorithm, have been successfully used to overcome the non-convexity

problems of the constrained ED (Bansal, 2005), (Huneault & Galiana, 1991). The GA method has usually better efficiency because the GA has parallel search techniques. Due to its high potential for global optimization, GA has received great attention in solving optimal power flow (OPF) problems. Fig. 1 shows the global strategy of the proposed approach to enhance the optimal power flow (OPF) in the presence of multi shunt FACTS devices and a multi distribution generation. A number of approaches for placement of DG to minimize losses have been proposed (Keane & O'Malley, 2006). Wang & Nehrir (2004) proposed a method which places DG at the optimal place along feeder and within networked systems with consideration of losses. Choudhry & Hanif (2006) proposed a strategy for voltage control for distribution networks with dispersed generation. Keane & O'Malley (2005) developed a methodology to optimally allocate DG capacity on the distribution network. The constraints taken in consideration were the voltage deviation, thermal limit, short circuit capacity. The methodology guarantees that the network capacity is maximized. Kuri & Redfern (2004) proposed a methodology based GA to place generators of discrete capacities in order to minimize losses and costs. Harrison et al. (2007) suggested a heuristic approach where an investment based objective function determines optimal DG site and size.

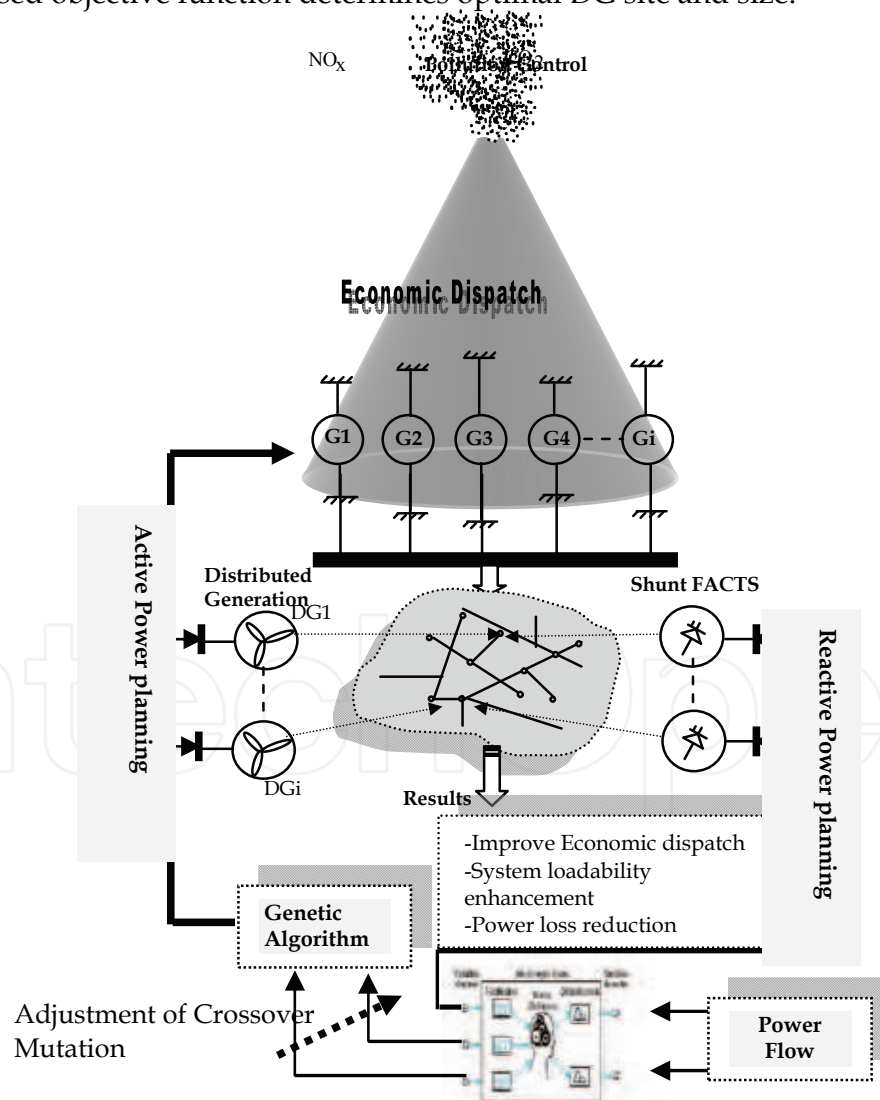

Fig. 1. Global strategy of OPF proposed with consideration of shunt FACTS and DG.

It is clear from the approaches cited in the literature that they offer optimal solution to the penetration of DG in a practical network, but not many approaches treat the problem of optimal coordination of multi DG with multi shunt FACTS devices to minimize fuel cost and improve the system security.

This Chapter presents a dynamic methodology for optimal allocation and sizing of multi DG units coordinated with multi shunt FACTS devices for a given practical distribution network, so that the cost of active power can be minimized. The proposed approach is based on a combined Genetic/Fuzzy Rules. The genetic algorithm generates and optimizes combinations of distributed power generation to be integrated to the network to minimize power losses, and in second step simple fuzzy rules based in practical expertise rules to control the reactive power of a multi dynamic shunt FACTS Compensators (SVC, STATCOM) designed to improve the system security. This proposed approach is implemented with Matlab program and applied to small case studies, IEEE 25-Bus and IEEE 30-Bus. The results obtained confirm the effectiveness of the proposed approach in sizing and integration of an assigned number of DG units in a practical network.

2. Active Power Planning

The active power planning problem is considered as a general minimization problem with constraints, and can be written in the following form:

$$\text{Minimize } f(x) \tag{1}$$

$$\text{Subject to: } g(x) = 0 \tag{2}$$

$$h(x) \leq 0 \tag{3}$$

$f(x)$ is the objective function, $g(x)$ and $h(x)$ are respectively the set of equality and inequality constraints. x is the vector of control and state variables. The control variables are generator active and reactive power outputs, bus voltages, shunt capacitors/reactors and transformers tap-setting. The state variables are voltage and angle of load buses. For optimal active power dispatch, the objective function f is the total generation cost expressed as follows:

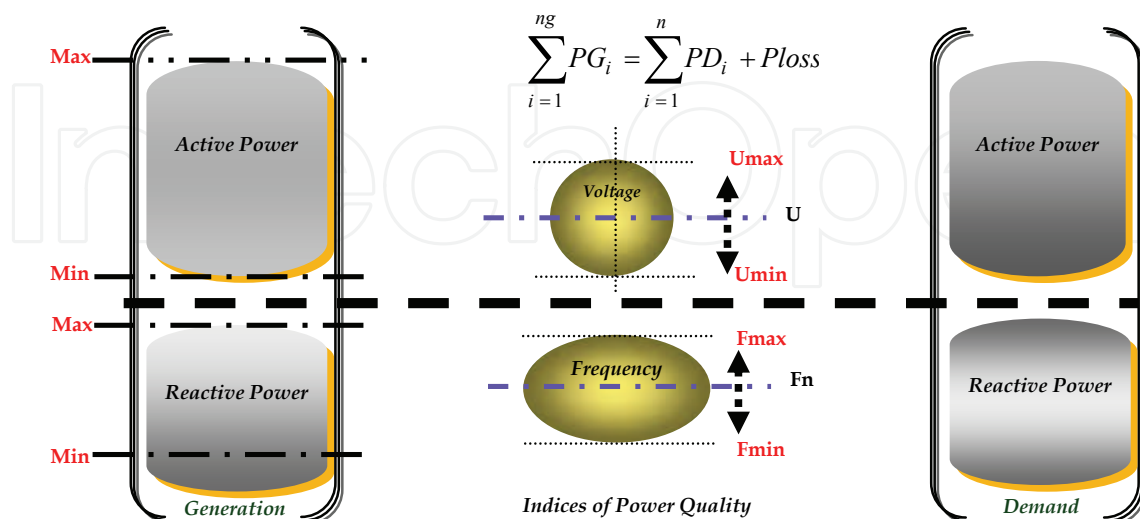

Fig. 2. Role of optimal power flow (OPF)

$$\text{Min } f = \sum_{i=1}^{N_g} (a_i + b_i P_{gi} + c_i P_{gi}^2) \quad (4)$$

where N_g is the number of thermal units, P_{gi} is the active power generation at unit i and a_i , b_i and c_i are the cost coefficients of the i^{th} generator.

The equality constraints $g(x)$ are the power flow equations, expressed as follows:

$$P_{gi} - P_{di} - \sum_{j=1}^N |V_i| |V_j| |Y_{ij}| \cos(\delta_i - \delta_j - \delta_{ij}) = 0 \quad (5)$$

$$\text{and } Q_{gi} - Q_{di} - \sum_{j=1}^N |V_i| |V_j| |Y_{ij}| \sin(\delta_i - \delta_j - \delta_{ij}) = 0 \quad (6)$$

The inequality constraints $h(x)$ reflect the limits on physical devices in the power system as well as the limits created to ensure system security:

- ▶ Upper and lower limits on the active power generations:

$$P_{gi}^{\min} \leq P_{gi} \leq P_{gi}^{\max} \quad (7)$$

- ▶ Upper and lower limits on the reactive power generations:

$$Q_{gi}^{\min} \leq Q_{gi} \leq Q_{gi}^{\max} \quad (8)$$

- ▶ Upper and lower bounds on the tap ratio (t).

$$t_{ij}^{\min} \leq t_{ij} \leq t_{ij}^{\max} \quad (9)$$

- ▶ Upper and lower bounds on the shifting (α) of variable transformers:

$$\alpha_{ij}^{\min} \leq \alpha_{ij} \leq \alpha_{ij}^{\max} \quad (10)$$

- ▶ Upper limit on the active power flow (P_{ij}) of line i - j .

$$|P_{ij}| \leq P_{ij}^{\max} \quad (11)$$

- ▶ Upper and lower bounds in the bus voltage magnitude:

$$V_i^{\min} \leq V_i \leq V_i^{\max} \quad (12)$$

- ▶ Upper and lower bounds in the Shunt FACTS parameters

$$X^{\min} < X_{FACTS} < X^{\max} \quad (13)$$

3. Strategy of the GA-Coordination Fuzzy Rules for DG-Shunt Facts

3.1 Principle of the Proposed Approach

A flexible methodology based in two-subproblem algorithm to solving the new formulation of optimal power flow (OPF) problem incorporates DG and shunt flexible AC transmission system (FACTS) is presented in Fig 3. The controllable FACTS devices considered include shunt compensators (SVC) and Static Compensator (STATCOM). The proposed algorithm decomposes the solution of such a modified OPF problem into three linked sub problems. The first subproblem is an active power generation by efficient Genetic Algorithm, and the

second subproblem is an active power planning of multi distributed generation to be integrated to the network to minimize power losses and the third subproblem is a reactive power planning coordinated with an efficient power flow problem to make fine adjustments on the optimum values obtained from the Genetic Algorithm. This will provide updated voltages, angles and point out generators having exceeded reactive limits.

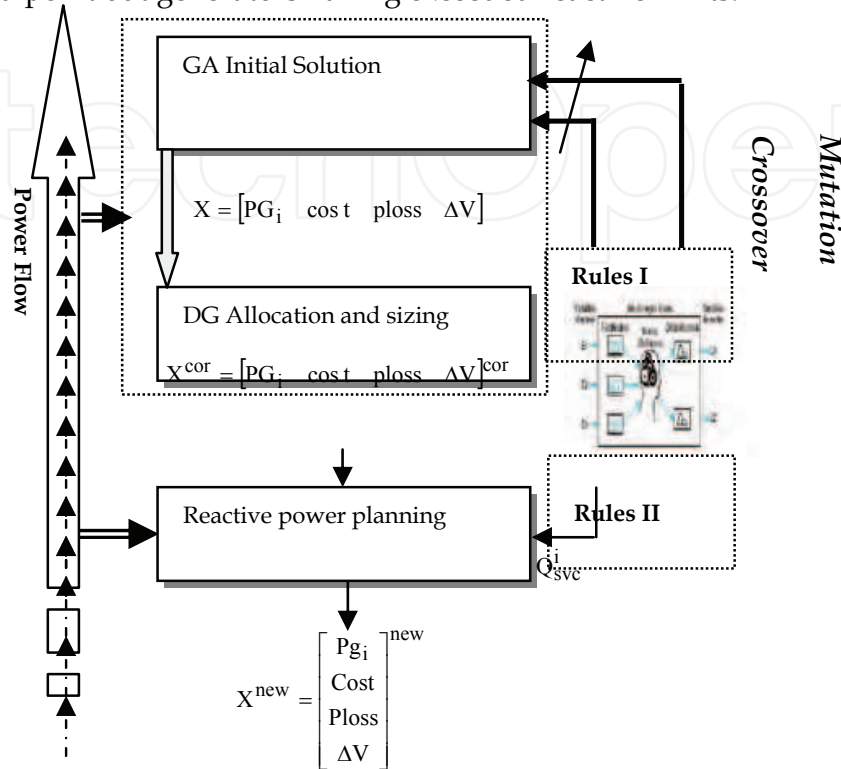

Fig. 3. Formulation mechanism of the proposed approach

Where:

- X : Initial vector solution generated by GA.
- X^{cor} : The corrected vector solution introduced by DG.
- X^{new} : The final vector solution after reactive power planning.
- ΔV : Voltage deviation.

3.2 Objective Functions

1) Fuel Cost Minimization

The objective function of the first subproblem is to minimize the total fuel cost without consideration of DG units.

$$\text{Min } J_1 = \sum_{i=1}^{NG} f_i \tag{14}$$

While f_i is the fuel cost (\$/h).

NG is the number of generators.

2) Power Loss Minimization

The objective function is modified to minimize the power losses while at the same time fuel cost minimized, the active power of the slack bus is adjusted in coordination with the active power delivered by the DG units. The objective function can be formulated as:

$$\text{Min } J_2 = P_{\text{loss}} \quad (15)$$

while P_{loss} is the power loss (MW)

4. Reactive Power Dispatch for Voltage Support

The goal here is to assure the minimum reactive exchanged between the dynamic shunt compensator and the network. Based in experience (Mahdad et al. (2007)) there is a maximum load increase on load margin with respect to the compensation level, the minimum reactive power is defined as the least amount needed from network system to maintain the same degree of system security. The problem can be formulated as a reactive power dispatch problem as follows.

$$\text{Max } RIS = \frac{\text{LoadFactor}(KLd)}{\sum_{i=1}^{NSVC} Q_{SVC}^i} \quad (16)$$

Subject to:

$$V_i^{\min} \leq V_i \leq V_i^{\max} \quad (17)$$

$$Q_{SVC}^{\min} \leq Q_{SVC}^j \leq Q_{SVC}^{\max} \quad (18)$$

Where;

RIS: reactive index sensitivity.

$NSVC$: the number of shunt compensator.

KLd : loading factor.

Q_{SVC} : Reactive power exchanged.

To solve the above optimization problem, we adopt a coordination rules based on heuristic strategy. A global data base is generated during the successive action.

Fig. 4 shows the principle of the proposed reactive index sensitivity to improve the economical size of shunt compensators installed in practical network.

In this Figure, the curve represents the evolution of minimum reactive power exchange based in system loadability; the curve has two regions, the feasible region which contains the feasible solution of reactive power. At point 'A', if the SVC outputs less reactive power than the optimal value such as at point 'B', it has a negative impact on system security since the voltage margin is less than the desired margin, but the performances of SVC

Compensator not violated. On the other hand, if the SVC produces more reactive power than the minimum value (Q_{\min}), such as point 'C', it contributes to improving the security

system with a reduced margin of system loadability, this reactive power delivered accelerates the saturation of the SVC Compensator.

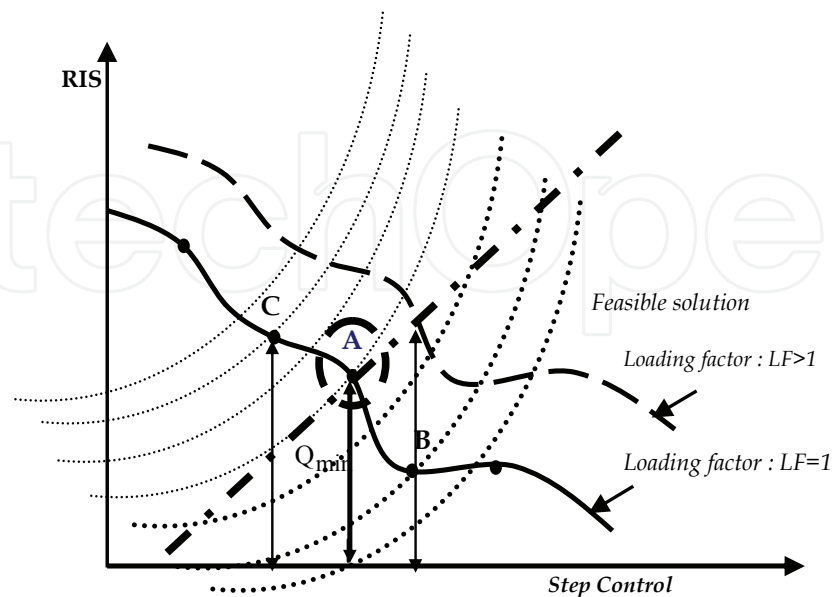

Fig. 4. Schematic diagram of minimum reactive power sensitivity

5. GA Solution for the Economic Dispatch

GAs are general purpose optimization algorithms based on the mechanics of natural selection and genetics [14]. They operate on string structure (chromosomes), typically a concatenated list of binary digits representing a coding of the control parameters (phenotype) of a given problem. Chromosomes themselves are composed of genes. The real value of a control parameter encoded in a gene, is called an allele.

A genetic algorithm is governed by three factors: the mutation rate, the crossover rate and the population size. GAs are search processes, which can be applied to unconstrained problems. Constraints may be included into the fitness function as added penalty terms [15].

a) Chromosome Type

Implementation of a problem in a GA starts from the parameter encoding. The encoding must be carefully designed to utilize the GA's ability to efficiently transfer information between chromosome strings and objective function of the problem. The encoded parameter is the power generation. Fig. 5 shows the structure of the proposed chromosome.

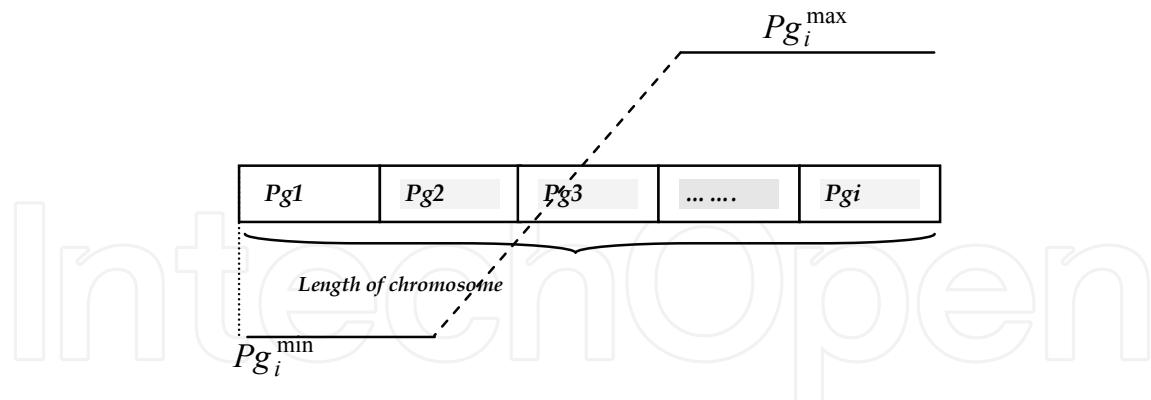

Fig. 5. Chromosome structure.

b) Fitness of Candidate Solution

Evaluation of a chromosome is accomplished by decoding the encoded chromosome string and computing the chromosome's fitness value using the decoded parameters. The fitness function adopted is given as:

$$Fitness = \frac{M}{f_i + Penalty_Q^V} \quad (19)$$

where M is the maximum possible cost of generation, Objective function is the generation cost and $Penalty_Q^V$ denotes a penalty for violating voltage limits V_j^{\min}, V_j^{\max} , and the penalty on the slack node for violating reactive power limit.

6. Fuzzy Logic Method

The use of fuzzy logic has received increased attention in recent years because of its usefulness in reducing the need for complex mathematical models in problem solving (Ng et al. (200)). Fuzzy logic employs linguistic terms, which deal with the causal relationship between input and output variables. For this reason, the approach makes it easier to manipulate and solve problems.

6.1 Fuzzy Rules for Crossover and Mutation Adjustment

For better results and to get faster convergence, conventional GA modes have been modified. In recent years various techniques have been studied to achieve this objective, these include (Bakistzis et al. (2002)):

- ▶ Using advanced string coding.
- ▶ Generating initial population with some prior knowledge (Todorovski & Rajičič, (2006)).
- ▶ Establishing some better evaluation function.
- ▶ Including new operators such as elitism, multi point or uniform crossover and creep mutation (Yalcinoz et al., (2001)).

This approach proposes a flexible Genetic Algorithm based on fuzzy logic rules with the ability to adjust continuously the crossover and mutation parameters. Fig. 6 presents the proposed block diagram of a fuzzy controlled genetic algorithm.

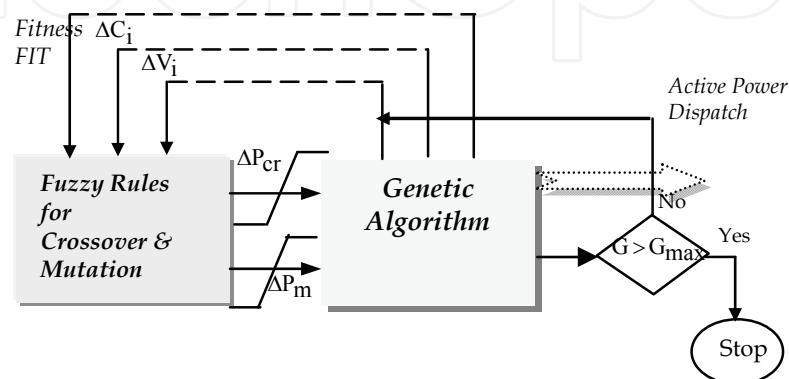

Fig. 6. Block diagram of the genetic parameters adjustment.

Crossover and mutation are considered critical for GA convergence. A suitable value for mutation provides balance between global and local exploration abilities and consequently results in a reduction of the number of iterations required to locate the good near solution. Experimental results based in application of GA to many practical networks at normal and abnormal conditions with load incrementation indicated, that it is better to adjust dynamically the value of the two parameters crossover and mutation.

It is intuitive that for a small variation in the chromosomes in a particular population, the effect of crossover during this critical stage becomes insignificant therefore, creating diversity in the population is required by increasing mutation (High value) probability of the chromosome and reducing (Low value) the value of crossover, note that the terms, small and high are linguistic.

The proposed approach employs practical rules interpreted in fuzzy logic rules to adjust dynamically the two parameters (crossover and mutation) during execution of the GA standard algorithm.

6.2 Membership Function Design

The membership function adopted by engineer differs from person to person and depends in problem difficulty therefore they are rarely optimal in terms of reproduced desired output.

1)Inputs and Outputs of Crossover and Mutation Fuzzy Controller

The inputs of the crossover fuzzy controller are changes of chromosomes fitness, the diversity in the cost generation, and voltage deviation, the output is the rate variation in

crossover. The inputs and outputs of mutation are the same of crossover fuzzy controller. A sample rules for crossover and mutation changes is presented in Fig. 7.

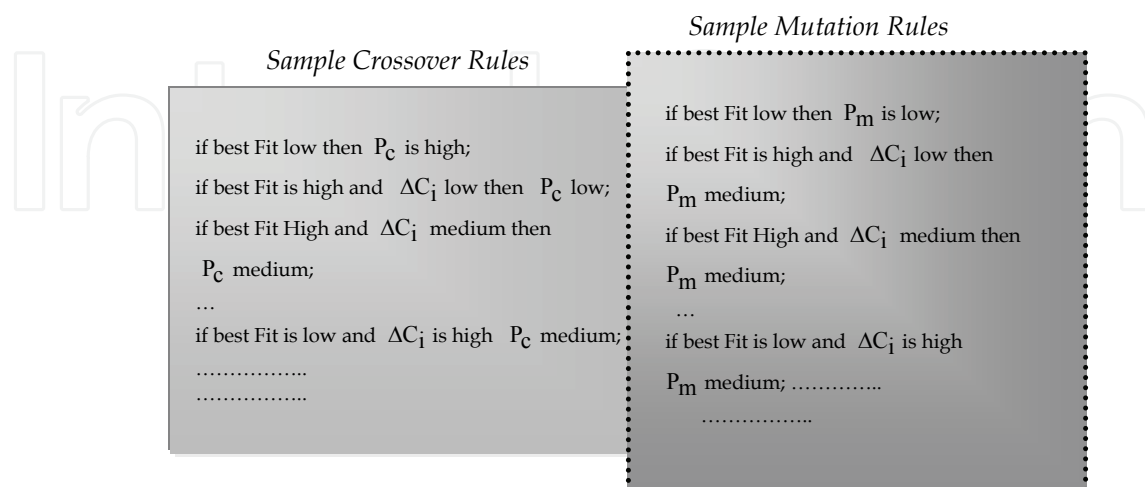

Fig. 7. Sample rules for crossover and mutation tuning

In this study, the upper and lower value for crossover probability and mutation probability, respectively are changed based in membership function for each variable from 0.9 to 0.4 and from 0.01 to 0.1. The consequent effects on the final value of crossover probability and mutation probability are calculated using the following equations:

$$P_c^{(t)} = P_c^{(t-1)} + \Delta P_c \quad (20)$$

$$P_m^{(t)} = P_m^{(t-1)} + \Delta P_m \quad (21)$$

where, $P_c^{(t)}$, $P_m^{(t)}$ are respectively the crossover and mutation probability at the iteration 't'.

6.3 Fuzzy Rules for Reactive Power Planning

The fuzzy variables associated with Reactive Power Planning Problem 'RPP' of a multiple dynamic shunt compensator are stated below.

1) Fuzzy Input Variables

- ▶ Bus voltage
- ▶ Active Power loss
- ▶ Reactive Power loss

2) Fuzzy Output Variables

- ▶ Voltage regulation for the shunt compensator.

3) Membership Function

A membership function uses a continuous function in the range [0-1]. It is usually decided from human expertise and observations made and it can be either linear or non-linear. This

choice is critical for the performance of the fuzzy logic system since it determines all the information contained in a fuzzy set. Engineers experience is an efficient tool to achieve a design of an optimal membership function, if the expert operator is not satisfied with the conception of fuzzy logic model, he can adjust the parameters used to the design of the memberships functions to adapt them with new database introduced to the practical power system. Fig. 8 shows the general block diagram of the proposed coordinated fuzzy approach applied to enhance the system loadability with minimum reactive power exchanged. Fig. 9 shows the combined of the voltage, active power and reactive power as input to the shunt compensator controller.

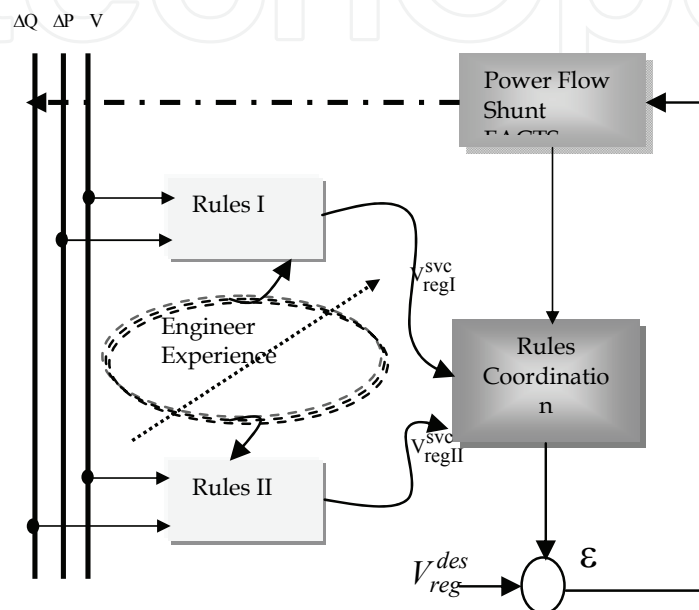

Fig. 8 Diagram of the proposed coordinated fuzzy approach

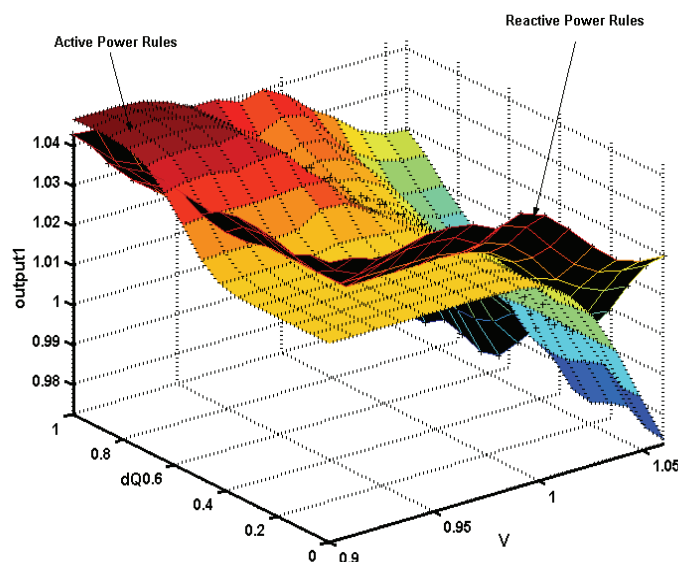

Fig. 9. Combination voltage, active and reactive power rules. The solution algorithm steps for the fuzzy control methodology are as follows:

1) Initial database:

Introduce the initial vector solution for power generation

$$X^{cor} = [PG_i \quad cost \quad ploss \quad \Delta V]^{cor}$$

Introduce the initial vector solution for distribution generation units DG_i .

2) Perform the initial operational power flow to generate the initial database $(V_i, \Delta P, \Delta Q)$.

3) Identify the candidate bus using continuation load flow.

4) Install the specified dynamic shunt compensator to the best bus chosen, and generate the reactive power using power flow based in fuzzy expert approach.

7. Shunt Facts and DG Modeling

7.1 Steady State Model of DG

The proposed approach requires the user to define the number of DG units to be installed based in voltage stability index (loading factor). The genetic algorithm generates and optimizes combination of DG sizes. For each combination of solution. Power losses and minimal cost used as a fitness function for the GA.

DG units modelling depend on the constructive technology and their combined active and reactive power control scheme (Golshan & Arefifar, (2006)).

In this study DG has been considered as not having the capability to control voltages, and therefore, it has been modelled in power flow study as a negative load, as a PQ node. Dynamic shunt compensators (SVC and STATCOM) modelled as a PV node used in coordination with DG to control the voltage by a flexible adjustment of reactive power exchanged with the network. Fig. 10 shows the proposed combined model of DG and SVC.

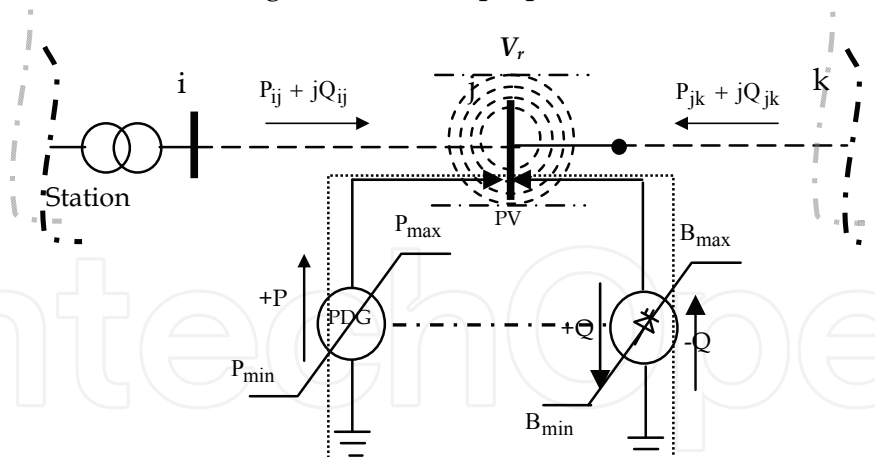

Fig. 10. The proposed combined model of DG/SVC Compensators integrated in power flow algorithm

7.2 Static VAR Compensator (SVC)

The steady-state model proposed in (Feurt-Esquivel et al., (1998)) is used here to incorporate the SVC on power flow problems. This model is based on representing the controller as a variable impedance, assuming an SVC configuration with a fixed capacitor (FC) and

Thyristor Controlled Reactor (TCR) as depicted in Fig. 11. Applying simultaneously a gate pulse to all thyristors of a thyristor valve brings the valve into conduction. The valve will block approximately at the zero crossing of the ac current, in the absence of firing signals. Thus, the controlling element is the Thyristor valve. The thyristors are fired symmetrically, in an angle control range of 90 to 180 with respect to the capacitor (inductor) voltage.

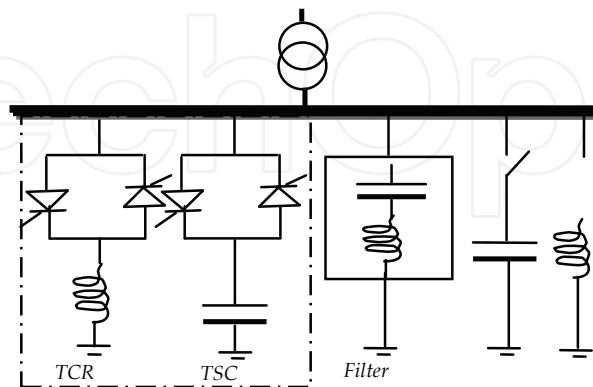

Fig. 11. Basic circuit representation of SVC Compensator

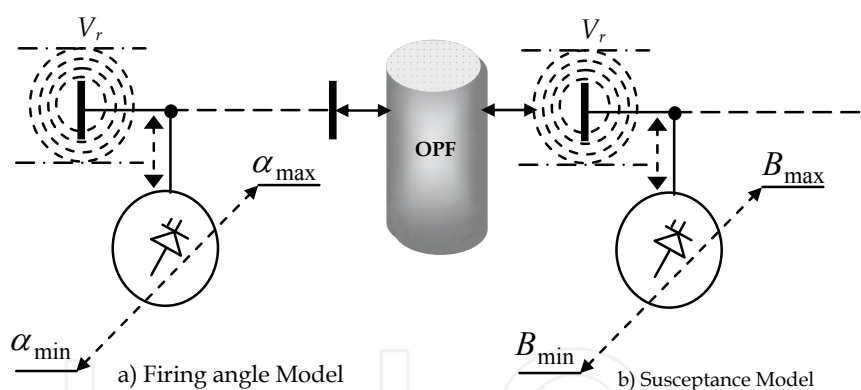

Fig. 12. Steady state model representation of SVC Compensator

$$V = V_{ref} + X_{sl}I \quad (22)$$

X_{sl} is in the range of 0.02 to 0.05 p.u. with respect to the SVC base. The slope is needed to avoid hitting limits. At the voltage limits the SVC is transformed into a fixed reactance. The total equivalent impedance X_e of SVC may be represented by

$$X_e = X_C \frac{\pi/k_X}{\sin 2\alpha - 2\alpha + \pi(2 - 1/k_X)} \quad (23)$$

where $k_X = X_C / X_L$ and $B_e = 1/X_e$

The SVC is usually connected to the transmission system through a step-down transformer,

which is treated in a similar manner as other transformers in the system.

Steady-state limits of the firing angle are $90^0 < \alpha < 180^0$

Where partial conduction is obtained. Firing angles less than 90^0 are not allowed, as they produce unsymmetrical current with a high dc component.

7.3 Multi Function Control

The objective function of the multi control functional operation of a coordinated multi DG with shunt FACTS devices is the combination from the prescribed control targets:

$$F_{DG/SVC} = \alpha_1 |P - P^{des}| + \alpha_2 |Q - Q^{des}| + \alpha_3 |V - V^{des}| \quad (24)$$

where P^{des} , Q^{des} , and V^{des} are the control targets of active and reactive power flow along line, and voltage of bus K, respectively. Fig. 13 illustrates the three combined voltage active and reactive power control.

Coefficients α_1 , α_2 , and α_3 can take 1 or 0 based in the control strategy adopted.

For a power system with N_{DG} and N_{SVC} devices integrated in practical network to enhance the power flow control, the optimization objective is:

$$\text{Min } F \quad (25)$$

The mathematical descriptions of the three control modes of coordinated multi DG with shunt Compensators are presented as follows.

Target 1: Bus Voltage Control

The bus Voltage control constraint is given by

$$V_m - V_m^{des} = 0 \quad (26)$$

where V_m^{des} is the desired bus voltage control

Target 2: The active Power Flow Control

$$P_{mk} - P_{mk}^{des} = 0 \quad (27)$$

where P_{mk}^{des} is the desired active power control

Target 3: The Reactive Power Flow Control

$$Q_{mk} - Q_{mk}^{des} = 0 \quad (28)$$

where Q_{mk}^{des} is the desired reactive power control.

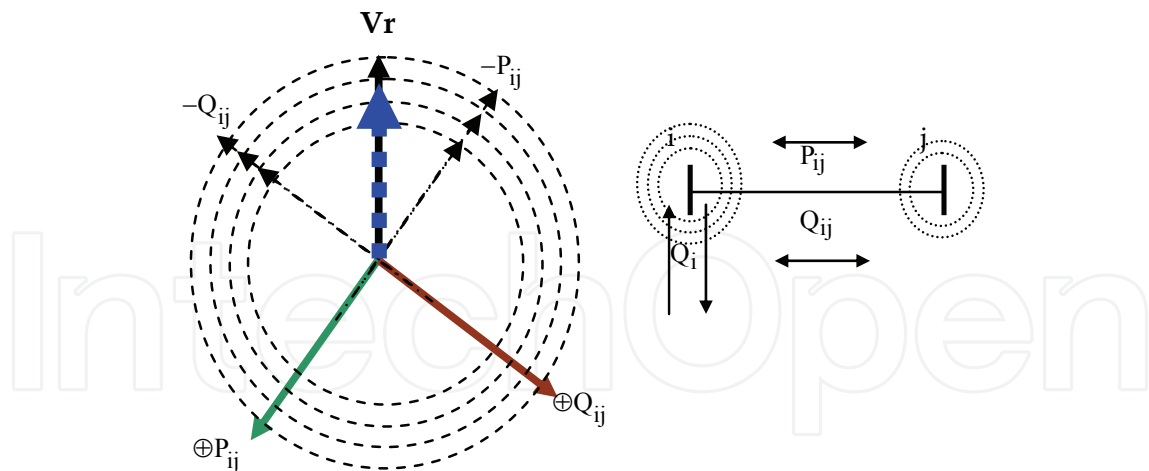

Fig. 13. Three control mode: voltage, active and reactive power control

8. Case Studies

The combined GA/Fuzzy rules is coded in Matlab program, two test cases were used to demonstrate the performance of the proposed algorithm. Consistently acceptable results were observed.

8.1 Case Studies on the IEEE 30-Bus System

The first test is the IEEE 30-bus, 41-branch system, for the voltage constraint the lower and upper limits are 0.9 p.u and 1.1 p.u., respectively, (except for PV buses where ($V_{max}=1.1$ p.u.)). For the purpose of verifying the efficiency of the proposed approach, we made a comparison of our algorithm with others competing OPF algorithm. Bakistzis et al. (2002) presented an enhanced GA (EGA), Bouktir et al. (2008) presented a standard GA, and an Ant Colony Optimization (ACO) proposed by Bouktir et al. (2007) to solve the economic dispatch problem. Saini et al. (2006) developed a Fuzzy GA (FGA) for OPF. The operating cost in our proposed approach is 801.3445 \$/h and the power loss is 9.12 MW which are better than the others methods reported in the literature. Results depicted in Table 1 shows clearly that the proposed approach gives better results. Table 2 shows the results of the reactive power generation and phase angle for the PV bus. Table 3 shows the best solution of dynamic shunt compensation obtained at the standard load demand ($P_d=283.4$ MW) using reactive power planning.

Variables	GA/FRules	SGA	EGA	ACO	FGA
P1(MW)	180.12	179.367	176.20	181.945	175.137
P2(MW)	44.18	44.24	48.75	47.0010	50.353
P5(MW)	19.64	24.61	21.44	20.5530	21.451
P8(MW)	20.96	19.90	21.95	21.1460	21.176
P11(MW)	14.90	10.71	12.42	10.4330	12.667
P13(MW)	12.72	14.09	12.02	12.1730	12.11
Cost (\$/hr)	801.3445	803.699	802.06	802.578	802.0003
Ploss (MW)	9.120	9.5177	9.3900	9.8520	9.494

Table 1. Results of the Minimum Cost and Power Generation Compared to SGA, EGA, ACO and FGA for IEEE 30-Bus

Variables	GA/Fuzzy Rules	SGA	FGA
Q1(Mvar)	-4.50	-3.156	-6.562
Q2(Mvar)	30.71	42.543	22.356
Q5(Mvar)	22.59	26.292	30.372
Q8(Mvar)	37.85	22.768	18.89
Q11(Mvar)	-2.52	29.923	21.737
Q13(Mvar)	-13.08	32.346	22.635
θ_1 (deg)	0.00	0.000	0.00
θ_2 (deg)	-3.448	-3.674	-3.608
θ_5 (deg)	-9.858	-10.14	-10.509
θ_8 (deg)	-7.638	-10.00	-8.154
θ_{11} (deg)	-7.507	-8.851	-8.783
θ_{13} (deg)	-9.102	-10.13	-10.228

Table 2. Results of the Reactive Power Generation and Phase Angle of GA/Fuzzy Rules Compared to SGA, FGA for IEEE 30-Bus.

Shunt N°	1	2	3	4	6	7	8	9
Bus N°	10	12	15	17	21	23	24	29
Best Qsvc [pu]	0.155	0.0798	0.03012	0.0495	0.0615	0.0384	0.0458	0.025
bsh [pu] [14]	0.05	0.05	0.03	0.05	0.05	0.04	0.05	0.03

Table 3. Comparative Results of the Shunt Reactive Power Compensation for IEEE 30-Bus

8.2 Case Studies on the IEEE 25-Bus test System without SVC and DG Installation

The proposed approach has been tested on IEEE 25-bus electrical network. It consists of 25 buses, 35 branches (lines and transformers), 5 generators and 24 loads.

1) Initial OPF with Genetic Algorithm

In this first step, DG and dynamic shunt compensation are not taken in consideration, for the voltage constraint the lower and upper limits are 0.94 p.u and 1.06 p.u., respectively. The GA population size is taken equal 30, the maximum number of generation is 100, and crossover and mutation are applied with initial probability 0.95 and 0.01 respectively. 10 test runs were performed; the convergence of this initial OPF is shown in Fig. 14.

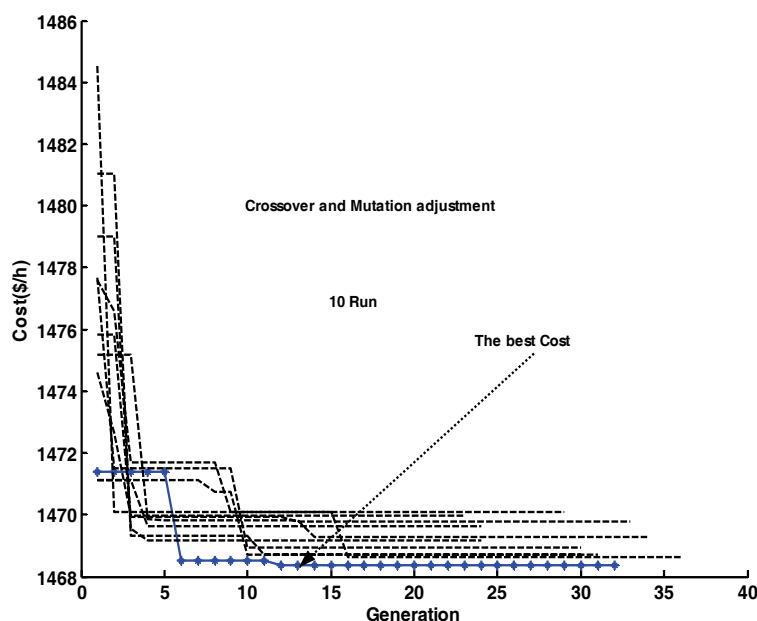

Fig. 14. Convergence for GA for the initial power generation subproblem with crossover and mutation adjustment (IEEE 25-bus).

Bus	V (p.u)	Pg (MW)	Qg (Mvar)
1	1.051	164.95	23.357
2	1.052	89.00	7.3780
3	1.043	81.82	34.748
4	1.012	20.98	24.699
5	1.042	184.58	15.600
PD (MW)		530.00	
Ploss (MW)		11.332	
Cost (\$/hr)		1467.9	

Table 4. shows the results of the generators voltage, active and reactive power generation without DG and shunt FACTS devices.

2) Optimal Placement of Shunt FACTS and DG

Before the insertion of SVC and DG devices, the system was pushed to its collapsing point by increasing both active and reactive load discretely using continuation load flow. In this test system according to results obtained from the continuation load flow, we can find that based

in Fig. 13 that buses 15, 22, 24, 25 are the best location points for initial installation of DG and reactive power planning for multi SVC Compensators.

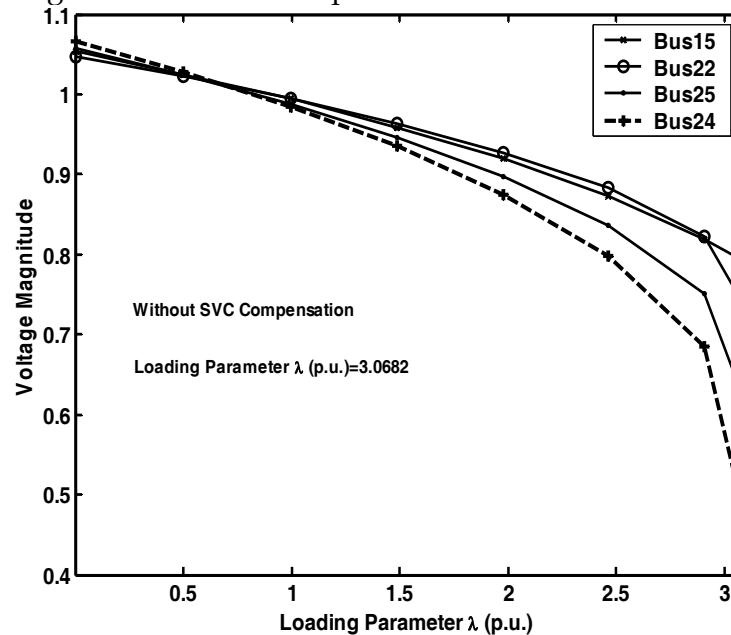

Fig. 13. Critical buses identification using load incrementation without DG and SVC installation ($\lambda=3.0682$).

3) Optimal Active Power Planning for DG for Power Loss Reduction

In this step the fuzzy controlled genetic algorithm with the same initial crossover and mutation parameter is used to generate and optimizes the active power of multi distributed generation to minimize power losses. Fig. 15 shows the best solution obtained at different load incrementation.

Loading λ	0%	1%	2%	3%	4%	5%
Dg15	0	0.0130	0.0242	0.0338	0.0482	0.0586
Dg21	0	0.0128	0.0258	0.0396	0.0520	0.0650
Dg22	0	0.0124	0.0172	0.0104	0.0148	0.0450
Dg24	0	0.0018	0.0144	0.0372	0.0442	0.0306
Dg25	0	0.0094	0.0208	0.0348	0.0492	0.0622
Ploss	0.11332	0.11568	0.11076	0.10715	0.10502	0.1036
Cost	1467.9	1469.3	1468.1	1467.2	1466.8	1466.5
PD	5.3000	5.353	5.406	5.459	5.512	5.565
Pg1	1.6495	1.6555	1.6506	1.6466	1.6448	1.6434

Table 5. Results of Active Power Planning with Load Incrementation.

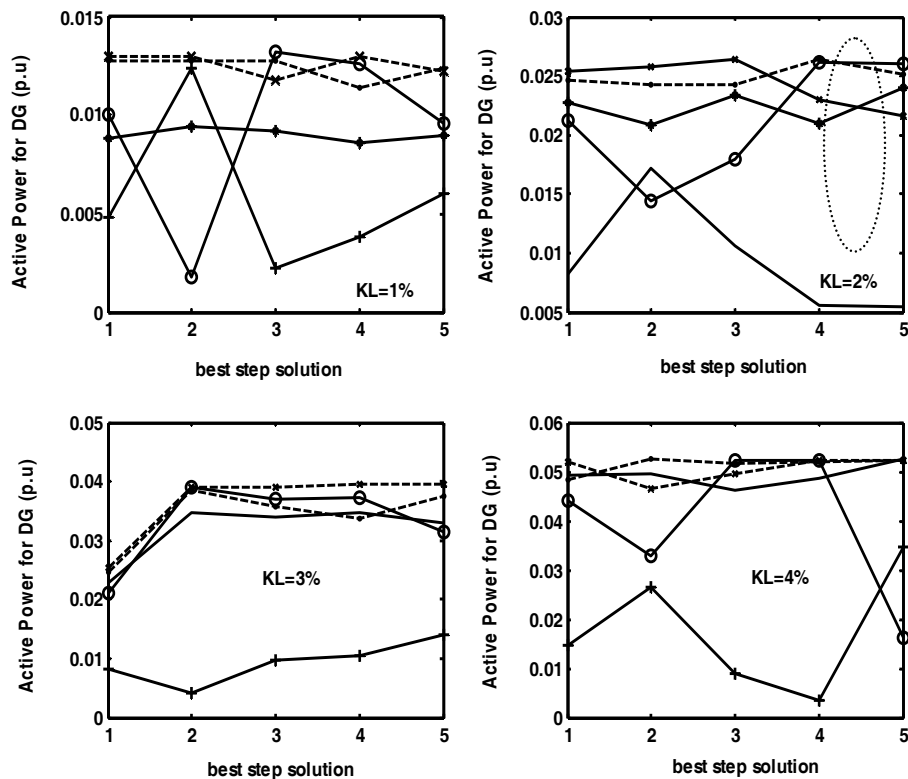

Fig. 15. The best solution (5 run) with load incrementation: (KL=1-4%)

4) System loadability Enhancement with Efficient Reactive Power Planning for Multi SVC Installation

In this second step, the initial SVC data used to control the reactive power are presented in Table 4. To demonstrate the efficiency of the reasoning fuzzy rules designed as a second subproblem to control the reactive power exchanged with the network, the algorithm applied again on the IEEE 25-bus.

From Table 5, it is observed that there is a decrease in power loss due to the integration of DG. Table 7 shows the results of the reactive power planning for the shunt FACTS devices installed at the critical buses. Fig. 16 shows that the system loadability is enhanced (3.4453 p.u) compared to the case (3.0682 p.u) without DG and shunt FACTS devices installation. Fig. 17 shows clearly that the voltage profile is enhanced at the base case (530 MW). Fig. 18 illustrates the exchanged reactive power between the shunt compensators and the network at different loading factor. Fig. 19 shows the active power exchanged between the distributed generation and the network at different loading factor.

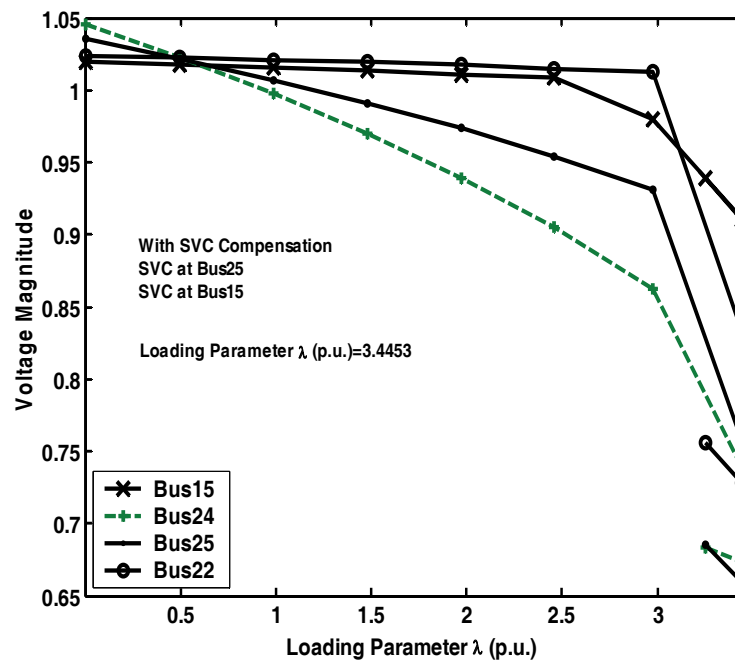

Fig. 16. Voltage profile improvement for the critical buses with SVC installation with load incrementation ($\lambda=3.4453$).

Table 6. SVCs data

		Bmin (p.u)	Bmax (p.u)	Binit (p.u)		
Susceptance SVC Model		-0.35	0.35	0.035		
Reactive Power (p.u)	0%	1%	2%	3%	4%	5%
$Q_{svc\ 15}$	0	-0.06545	0.00091	0.06924	0.13723	0.19889
$Q_{svc\ 21}$	0	-0.03883	0.03221	0.10459	0.17904	0.24125
$Q_{svc\ 22}$	0	-0.05308	-0.04193	-0.02599	-0.01366	-0.01093
$Q_{svc\ 24}$	0	0.06026	0.05544	0.04669	0.04390	0.04726
$Q_{svc\ 25}$	0	-0.07026	-0.04735	-0.02466	-0.00158	0.02157
Q_{G1}	0.23357	0.32462	0.23159	0.13585	0.03958	-0.04922
Q_{G2}	0.07378	0.07638	0.07898	0.08161	0.08427	0.08682
Q_{G3}	0.34748	0.37618	0.35897	0.34182	0.32468	0.30747

Q_{G4}	0.24699	0.28302	0.25136	0.22124	0.19151	0.15712
Q_{G5}	0.15600	0.19297	0.16237	0.13209	0.10183	0.07083
PD (p.u)	5.3000	5.353	5.406	5.459	5.512	5.565

Table 7. Results of Reactive Power Planning with Load Incrementation.

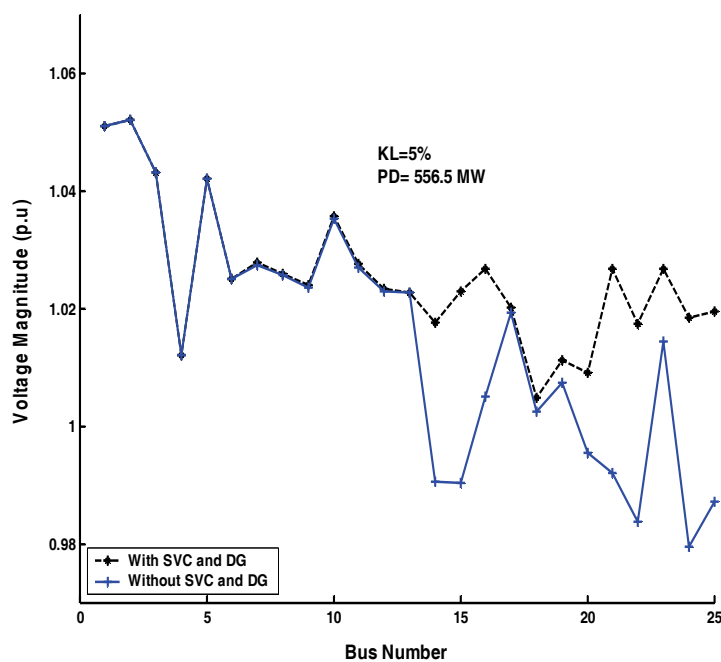

Fig. 17. Voltage profile in two cases: without SVC/DG, and with SVC/DG

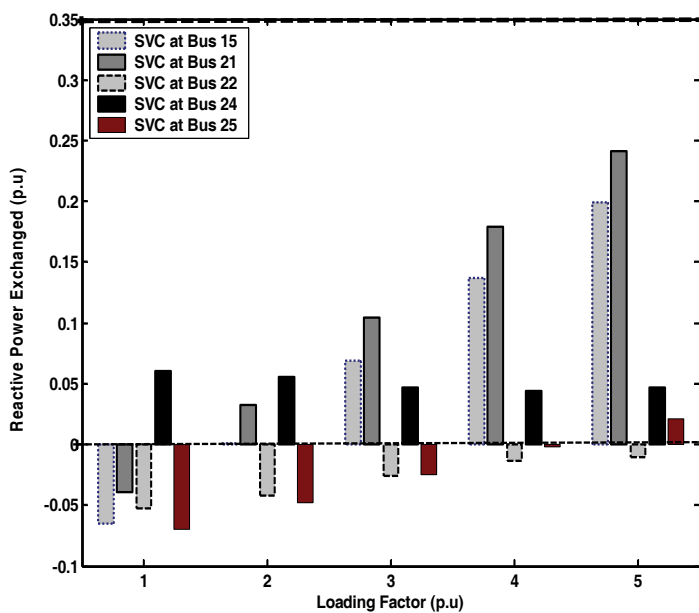

Fig. 18. Reactive power exchanged with the network at different loading factor.

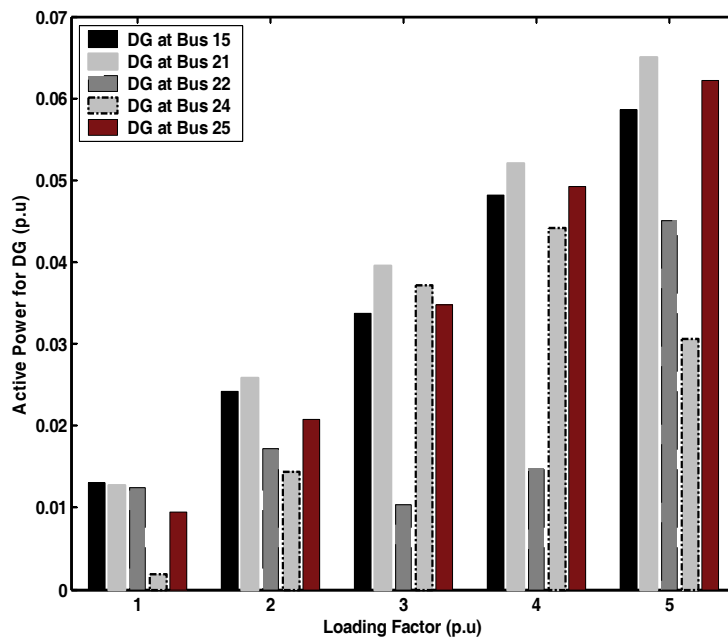

Fig. 19. Active power of DG exchanged with the network at different loading factor.

9. Discussions

It is clear from results depicted in Table 7 that the dynamic voltage control using shunt FACTS Compensators has a significant impact on the potential integration of DG.

The power losses and correspondingly the optimal cost for the standard generation are enhanced at an acceptable technical values considering load incrementation, for example at loading factor $KL=5\%$ the power losses reduced to 10.36 MW and the cost maintained to 1466.5 \$/hr compared to the base case.

It has found that based on the dynamic reactive index sensitivity introduced the expert engineer can choose economically the size of the shunt Compensators to be installed in a practical network. The proposed new size of shunt dynamic Compensators are depicted in Table 8. The size of the SVC installed at bus 22, 24, 25 reduced from the initial value 0.35 p.u to 0.1 p.u.

Further research is required to include the real cost of DG units into the objective function.

Bus	Initial SVC Size	New SVC Size	Marge Security utilization in %
15	$-0.35 < Q_{SVC} < 0.35$	$-0.35 < Q_{SVC} < 0.35$	56.83
21	//	$-0.35 < Q_{SVC} < 0.35$	68.93
22	//	$-0.10 < Q_{SVC} < 0.10$	10.93
24	//	$-0.10 < Q_{SVC} < 0.10$	47.26
25	//	$-0.10 < Q_{SVC} < 0.10$	21.57

Table 8. SVC Size

10. Conclusion

An approach combining Genetic Algorithm and fuzzy logic expert rules aims to demonstrate the importance of finding the best locations and sizes of a distribution generation to be integrated dynamically in a practical network.

One might think that the larger size of DG or shunt dynamic Compensators, the greater increase in the maximum load, based in experience and results given in this paper that this is not always true. There is a maximum increase on load margin with respect to the compensation level for shunt FACTS devices and active power injected by DG. The objective of the proposed approach is to coordinate and adjust the active power for DG and the reactive power exchanged with dynamic Compensators and the network to minimize fuel cost and to improve the index power quality (voltage deviation, power losses).

11. References

- Méndez, V. H.; Rivier, J. & Gomez, T. (2006), Assessment of Energy Distribution Losses for Increasing Penetration of Distribution Generation. *IEEE Trans. Power Systems*, vol. 21, n. 21, 533-5400.
- Vovos, P. N.; Kiprakis, A. E.; Wallace, A. R. & Harison, G. P (2007). Centralized and Distribution Voltage Control: Impact on Distribution Generation Penetration. *IEEE Trans. Power Systems*, vol. 22, n. 1, 476-683.
- Mahdad, B.; Bouktir, T. & Srairi, K. (2007). Flexible methodology based in fuzzy logic rules for reactive power planning of multiple shunt FACTS devices to enhance system loadability. *Power Engineering Society General Meeting, IEEE*, Page(s):1-6, Digital Object Identifier 10.1109/PES.2007.385750.
- Bansal, R. C. (2005). Optimization Methods for Electric Power Systems: An Overview. *International Journal of Emerging Electric Power Systems*, vol. 2, no. 1, 1-23.
- Huneault, M.; & Galiana, F. D. (1991). A Survey of the Optimal Power Flow Literature. *IEEE Trans. Power Systems*, vol. 6, no. 2, 762-770.
- Keane, A.; & O'Malley, M. (2006). Impact of distribution generation capacity on losses," in *Proc. IEEE*, pp. 1-7.
- Wang, C.; & Nehrir, M. H. (2004). Analytical approaches for optimal placement of distribution generation sources in power systems. *IEEE Trans. Power Systems*, vol. 19, no. 4, pp. 2068-2076.
- Hanif, A. & Choudhry, M. A. (2006). Investigation smooth power flow control for dispersed generator working parallel to the grid system on the level load. *In Proc. PSCE*, 2241-2248.
- Keane, A. & O'Malley, M. (2005). Impact of distribution network constraints on distribution generation capacity. *In Proc. of 40th International Universities power engineering conference, Cork*.
- Kuri, B.; Redfern, M. & Li, F. (2004) .Optimization of rating and positioning of dispersed generation with minimum network disruption. *In Proc. IEEE Power Eng. Soc. Gen. Meeting, Denver, CO*, 2074-2078.
- El-Khaltam, W.; Bhattacharya, K.; Hegazy, Y. & Salama, M. M. A. (2004). Optimal investment planning of distributed generation in a competitive electricity market. *IEEE Trans. Power Syst.*, vol. 19, no. 3,1674-1684.

- Harrison, G. P.; Piccolo, A.; Siano, P. & Wallace, A. R. (2007). Distributed generation capacity evaluation using combined genetic algorithm and OPF. *International Journal of Emerging Electric Power Systems*, vol. 8, Issue. 2.
- Mahdad, B.; Bouktir, T. & Srairi. K. (2007). Methodology based in practical fuzzy rules coordinated with asymmetric dynamic compensation applied to the unbalanced distribution network. *International Review of Electrical Engineering (IREE)*, vol. 3, no. 2, 145-153, ISSN 1827- 6660, Praise Worthy Prize, Italy.
- Bakistzis, A. G.; Biskas, P. N.; Zoumas, C. E.; & Petridis, V. (2002). Optimal power flow by enhanced genetic algorithm. *IEEE Trans. Power Systems*, vol. 17, no. 2, 229-236.
- Davis, L. (1989). Adapting operator probabilities in genetic algorithms. In *Proc. 3rd Int. Conf. Genetic Algorithms Applications*, J. Schaffer, Ed., SanMateo, CA, 61-69.
- Ng, H. N.; Salama; Chikhani, M. M. A. & Chikhani, A.Y. (2000). Classification of capacitor allocation techniques," *IEEE Trans. Power Delivery*, vol. 15, no. 1, 387-392.
- Yalcinoz, T; Altun, H & Uzam, M. (2001). Economic dispatch solution using genetic algorithm based on arithmetic crossover," in *Proc. IEEE Porto Power Tech. Conf., Porto, Portugal*.
- Todorovski, M.; & Rajičič, D. (2006). An initialization procedure in solving optimal power flow by genetic algorithm. *IEEE Trans. Power Systems*, vol. 21, no. 2, 480-487.
- Iba, K. (1994). Reactive power optimization by genetic algorithm. *IEEE Trans. Power Systems*, vol. 9, no. 2, pp. 685-692.
- Lai, L. L.; Ma, J. T. R.; Yokoyama, & Zhao, M. Improved genetic algorithm for optimal power flow under both normal and contingent operation states. *Elec. Power Energy Syst.*, vol. 19, no. 5, 287-292, 1997.
- M. E. H. Golshan, and S. A. Arefifar, "Distribution generation, reactive sources and network-configuration planning for power and energy-loss reduction, " *IEE Proc.-Gener. Transm. Distrib.*, vol. 153, no2, pp. 127- 136, March 2006.
- Feurt-Esquivel, C. R.; Acha, E. Tan SG, JJ. Rico. (1998). Efficient object oriented power systems software for the analysis of large-scale networks containing FACTS controlled branches. *IEEE Trans. Power Systems*, vol. 13, no. 2, 464-472.
- Bouktir, T.; Slimani, L. & Mahdad, B. (2008). Optimal power dispatch for large scale power system using stochastic search algorithms. *International Journal of Power and Energy Systems*, vol. 28, no. 1, 1-10.
- Slimani, L. & Bouktir, T. (2007). Economic power dispatch of power system with pollution control using multiobjective ant colony optimization. *International Journal of Power and Computational Intelligence Research*, vol. 03, no. 2, 145-153, 2007.
- Saini, A.; Chaturvedi, D. K. & Saxena, A. (2006). Optimal power flow solution: a GA-Fuzzy system approach. *International journal of emerging electric power systems*, vol. 5, Issue. 2, 1-21.
- Canizares, C. A. (2000). Power flow and transient stability models of FACTS controllers for voltage and angle stability studies. *IEEE Proceeding*.
- Dhaoyun, G. & Chung, T. S. (1998). Optimal active power flow incorporating FACTS devices with power flow constraints, *Electrical Power & Energy Systems*, vol. 20, no. 5, 321-326.



Distributed Generation

Edited by D N Gaonkar

ISBN 978-953-307-046-9

Hard cover, 406 pages

Publisher InTech

Published online 01, February, 2010

Published in print edition February, 2010

In the recent years the electrical power utilities have undergone rapid restructuring process worldwide. Indeed, with deregulation, advancement in technologies and concern about the environmental impacts, competition is particularly fostered in the generation side, thus allowing increased interconnection of generating units to the utility networks. These generating sources are called distributed generators (DG) and defined as the plant which is directly connected to distribution network and is not centrally planned and dispatched. These are also called embedded or dispersed generation units. The rating of the DG systems can vary between few kW to as high as 100 MW. Various new types of distributed generator systems, such as microturbines and fuel cells in addition to the more traditional solar and wind power are creating significant new opportunities for the integration of diverse DG systems to the utility. Interconnection of these generators will offer a number of benefits such as improved reliability, power quality, efficiency, alleviation of system constraints along with the environmental benefits. Unlike centralized power plants, the DG units are directly connected to the distribution system; most often at the customer end. The existing distribution networks are designed and operated in radial configuration with unidirectional power flow from centralized generating station to customers. The increase in interconnection of DG to utility networks can lead to reverse power flow violating fundamental assumption in their design. This creates complexity in operation and control of existing distribution networks and offers many technical challenges for successful introduction of DG systems. Some of the technical issues are islanding of DG, voltage regulation, protection and stability of the network. Some of the solutions to these problems include designing standard interface control for individual DG systems by taking care of their diverse characteristics, finding new ways to/or install and control these DG systems and finding new design for distribution system. DG has much potential to improve distribution system performance. The use of DG strongly contributes to a clean, reliable and cost effective energy for future. This book deals with several aspects of the DG systems such as benefits, issues, technology interconnected operation, performance studies, planning and design. Several authors have contributed to this book aiming to benefit students, researchers, academics, policy makers and professionals. We are indebted to all the people who either directly or indirectly contributed towards the publication of this book.

How to reference

In order to correctly reference this scholarly work, feel free to copy and paste the following:

Belkacem Mahdad, Tarek Bouktir and Kamel Srairi (2010). Optimal Coordination and Penetration of Distributed Generation with Multi Shunt FACTS Compensators Using GA/Fuzzy Rules, Distributed Generation, D N Gaonkar (Ed.), ISBN: 978-953-307-046-9, InTech, Available from:
<http://www.intechopen.com/books/distributed-generation/optimal-coordination-and-penetration-of-distributed-generation-with-multi-shunt-facts-compensators-u>

INTECH

open science | open minds

InTech Europe

University Campus STeP Ri
Slavka Krautzeka 83/A
51000 Rijeka, Croatia
Phone: +385 (51) 770 447
Fax: +385 (51) 686 166
www.intechopen.com

InTech China

Unit 405, Office Block, Hotel Equatorial Shanghai
No.65, Yan An Road (West), Shanghai, 200040, China
中国上海市延安西路65号上海国际贵都大饭店办公楼405单元
Phone: +86-21-62489820
Fax: +86-21-62489821

intechOpen

IntechOpen

© 2010 The Author(s). Licensee IntechOpen. This chapter is distributed under the terms of the [Creative Commons Attribution-NonCommercial-ShareAlike-3.0 License](#), which permits use, distribution and reproduction for non-commercial purposes, provided the original is properly cited and derivative works building on this content are distributed under the same license.

IntechOpen

IntechOpen