

We are IntechOpen, the world's leading publisher of Open Access books Built by scientists, for scientists

4,800

Open access books available

122,000

International authors and editors

135M

Downloads

Our authors are among the

154

Countries delivered to

TOP 1%

most cited scientists

12.2%

Contributors from top 500 universities

**WEB OF SCIENCE™**Selection of our books indexed in the Book Citation Index
in Web of Science™ Core Collection (BKCI)

Interested in publishing with us?
Contact book.department@intechopen.com

Numbers displayed above are based on latest data collected.

For more information visit www.intechopen.com

Ultrawideband Bandpass Filter using Composite Right- and Left-Handedness Line Metamaterial Unit-Cell

Sungtek Kahng

Abstract

The design of a new UWB bandpass filter is proposed, which is based upon the microstrip Composite Right- and Left-Handed Transmission-line(CRLH-TL). In order to bring the remarkable improvement in an attempt to reduce the size, taking the features of the conventional periodic CRLH-TL, only one unit of the structure is chosen. So the component less than a quarter-wavelength is realized to achieve the ultra wide band filtering without the loss of the original advantage of the CRLH-TL. Guaranteeing the compactness in size, the interdigitated coupled lines are used to realize the strong coupling for the design that will be shown to have the size of 'guided wavelength/9.4', the fractional bandwidth over 100%, the insertion loss much less than 1 dB, and the flat group-delay with an acceptable return loss performance in the predicted and measured results.

1. Introduction

In recent years, numerous studies have been conducted to exploit the benefits of the UWB communication, since its unlicensed use was open to the public by the US FCC. As one of many such research activities, the design methods of bandpass filters have been reported[6-10].

Araki et al [6] designed the UWB bandpass filter whose bandwidth is formed by adding zeros in the sections of the transmission line. The frequency response has notches at the specific points as the very narrow regions for out-of-band suppression. H. Wang et al [7] presented the microstrip-and-CPW bandpass filter for the UWB application, which is based upon the Multi-Mode Resonator(MMR) in the form of multiples of quarter-wavelength, to broaden the bandwidth and obtain the enlarged rejection region. The idea of the MMR of the half wavelength is also used in [8] where the coupled lines of a quarter-wavelength are used as the inverter. This work shows the extension of the lower and higher stopbands owing to the increased coupling. A composite UWB filter was designed by W. Menzel et al by combining lowpass and high pass filters as a suspended stripline structure with different planes[9]. Independently, C. Hsu et al presented the composite microstrip filters for the UWB application, where seven or eight TL sections of about quarter-wavelength are sequentially connected[10]. Presently, we describe the design method of a new UWB filter on the basis of the composite right- and left-handed transmission line(CRLH-TL)[11-13].

Different from the reference [11], we take just one segment (smaller than one quarter-wavelength) from the periodic structure of the CRLH-TL to make the component very compact. Besides, instead of mixing two types, for instance, hybrid of the microstrip and CPW, the filter design is pursued with only the microstrip. Most of all, what features in our present work is that the interdigital coupled lines much smaller than a quarter wavelength and the grounded stub account for the strong capacitive coupling and the inductance for the left-handedness, respectively, and the effective inductance of the interdigital capacitor and the effective capacitance of the short-circuited inductor are used to decide the right-handedness characteristics, in order to form a ultra wideband. And then going through the implementation process, the predicted performances of the designed filter are given with the measurement of the fabricated one to validate our design methodology, where the design of the proposed BPF reveals the suitability for the UWB application, showing the size reduction to the guided wavelength/9.4, the bandwidth more than 100%, the insertion loss lower than 1 dB, the group-delay variation less than 0.5 ns with the good return loss property.

2. Design of The Crlh-TI Type Uwb Bpf

The left-handed medium as a metamaterial has been examined theoretically and experimentally as it plays the lumped high pass filter circuit, and its unit cell in a periodic transmission line is smaller than the guided wavelength. Instead of the pure left-handedness, the CRLH-TL as a more practical circuit has been portrayed by C. Caloz et al [11]. It is represented by Fig. 2-1.

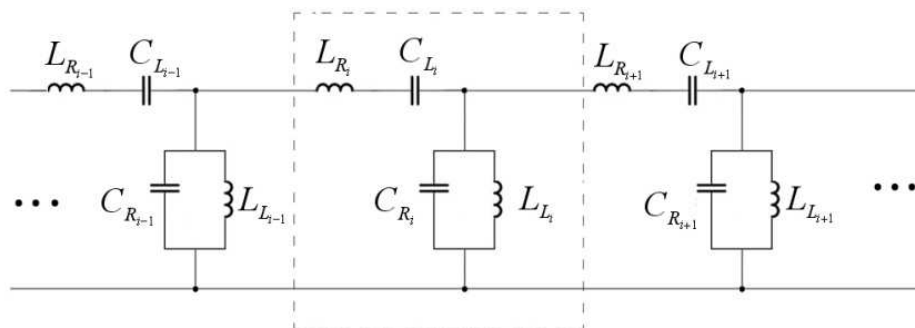

Fig. 2-1. Equivalent circuit model of the conventional periodic CRLH-TL

There are three intermediate units of the periodic CRLH-TL and the i -th segment is marked by the dotted line block in Fig. 1. The i -th segment consists of (C_{L_i}, L_{L_i}) for the left-handedness and (C_{R_i}, L_{R_i}) for the right-handedness property. From the standpoint of the purely left-handed unit, L_{R_i} and C_{R_i} can be considered parasitic inductance and capacitance against C_{L_i} and L_{L_i} , respectively. However, in our design, we use the effective inductance L_{R_i} and the effective capacitance C_{R_i} for the purpose of forming a pass-band for the UWB filter. As is addressed previously, only the basic unit, say, the i -th segment is taken for the present work. Its symmetric version can be expressed a Pi-equivalent circuit in Fig. 2-2.

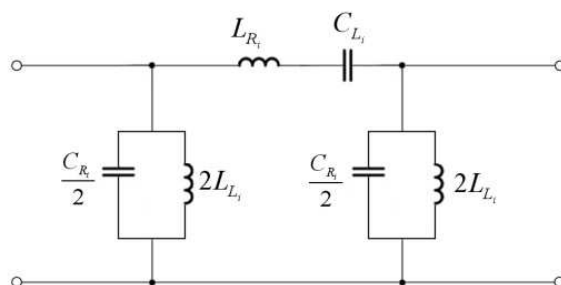

Fig. 2-2. Pi-equivalent circuit of the unit cell from the CRLH-TL

The ladder type of circuit in Fig. 1 has the exactly the same function as that in Fig. 2-2. But the difference between them is the physical configuration, and this will be shed a light on later. What is important in using the basic unit of the CRLH-TL in Fig. 2 is to determine the values of the elements (C_{Li} , L_{Li} , C_{Ri} , L_{Ri}) that produce the performances appropriate to the UWB BPF. We adopt the concept of the Balanced CRLH-TL in [11] to achieve a single broad band without any gap in between the cut-off frequencies of highpass and lowpass filtering. In the Balanced case, the three from four resonance phenomena lead to the following relations.

$$f_{Li} = \frac{1}{2\pi\sqrt{L_{Li}C_{Li}}} \quad , \quad f_{Ri} = \frac{1}{2\pi\sqrt{L_{Ri}C_{Ri}}} \quad (2-1)$$

$$f_{sei} = f_{shi} = f_o \quad , \quad f_o = \sqrt{f_{Li}f_{Ri}}$$

where

$$f_{sei} = \frac{1}{2\pi\sqrt{L_{Ri}C_{Li}}} \quad , \quad f_{shi} = \frac{1}{2\pi\sqrt{L_{Li}C_{Ri}}}$$

That f_{sei} is let equal to f_{shi} means the *balance* in the CRLH-TL, where f_{Li} , f_{Ri} , f_{sei} , f_{shi} , and f_o correspond to the lower band-edge, upper band-edge, series resonance point, shunt resonance point and center frequency, respectively. Solving the equations above, the circuit elements are identified.

In order for a BPF to have the ultra wideband, a strong coupling is essential to the implementation. In particular, the sufficient large amount of C_{Li} is required.



Fig. 2-3. Microstrip interdigital coupled lines and grounded stub

As explained in the introduction with other design cases where the hybrid of the microstrip/CPW or the cascaded transmissions of wavelengths are used, CLi should be large enough, as the designers' main concern. Like them, we need a strong capacitive coupling, but proceed with the microstrip interdigital coupled lines. Even if the interdigital

line has been around for quite some time, as is stated before, its geometric parameters will be explored to find the desired effective inductance L_{Ri} as well as C_{Li} in our design, different from others. Fig. 2-3 presents the typical interdigital line. The geometry of an n_{IDF} fingered interdigital line described with W , l and S denoting the finger width, the finger length and the spacing between the two adjacent fingers, respectively. The capacitance of Fig. 2-3 is given as follows.

$$C(pF) = \frac{\epsilon_{re} 10^{-3}}{18\pi} \frac{K(k)}{K'(k)} (n_{IDF} - 1)l \quad (2-2)$$

where

$$k = \tan^2\left(\frac{a\pi}{4b}\right), \quad a = \frac{W}{2}, \quad b = \frac{W+S}{2}$$

$K(\cdot)$ and $K'(\cdot)$ are the complete elliptic integral of the 1st kind and its complement. Along with the series interdigital line, the grounded shunt stub plays an important role. The expression as follows is commonly used for the inductance of the grounded stub and each finger in the interdigital line (L_{Ri}). Though it is an approximate formula, it helps us quickly approach the initial size.

$$L(nH) = 2 \times 10^{-4} l \left[\ln\left(\frac{l}{W+t}\right) + 1.193 + 0.224 \frac{W+t}{l} \right] \cdot K_g \quad (2-3)$$

where

$$K_g = 0.57 - 0.145 \ln\left(\frac{W}{h}\right)$$

h and t above mean the thickness of the substrate and metallization in use. The expressions for the other circuit elements are found in [9] and used to correct the electrical behaviors based upon Eqns (2) and (3). With all these values, physical sizes are iteratively exploited until the acquisition of the desired performance.

3. Results of Implementation

Use First of all, the interdigital line's size is calculated to realize the capacitance of 0.477pF and its effective inductance of 5.53nH. Via the iterative steps using Eq's (2) and (3), the initial values are found $W=0.20$ mm, $l=1.30$ mm, $S=0.12$ and $n_{IDF}=14$.

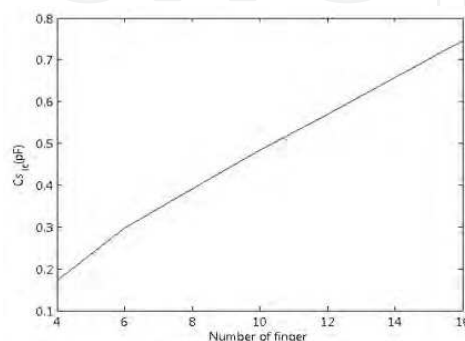

(a)

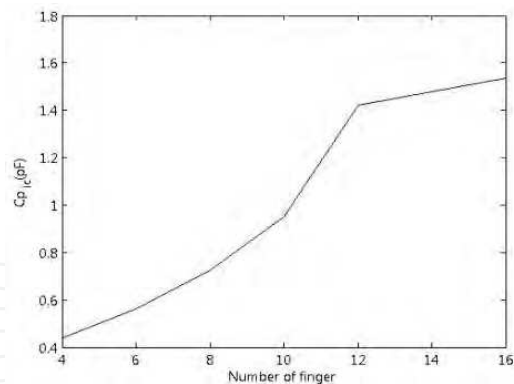

(b)

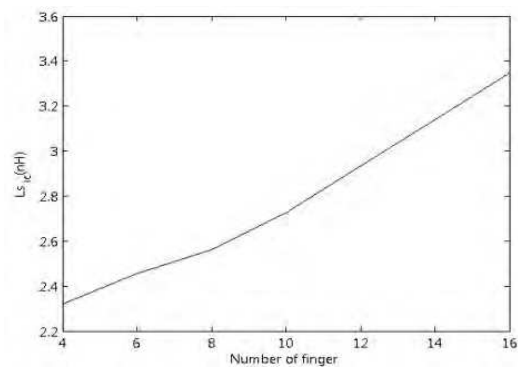

(c)

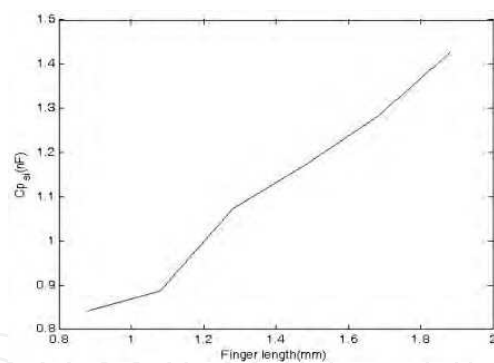

(d)

Fig. 2-4. Interdigital line's capacitance and inductance V.S. geometric changes (a) Number of fingers V.S. C_s (b) Number of fingers VS. C_p (c) Number of fingers V.S. L_s (d) Length of the finger V.S. C_p

This is followed by finding the physical dimensions of the grounded transmission line stub whose W and l are 0.5 mm and 5.0 mm with 1.13nH and 0.20pF. For the substrate, FR4($\epsilon_r = 4.4$) is used. And the circuit values result in the following dispersion diagram. Resorting to the conventional periodic CRLH-TL concept, just for convenience, we check the critical points, say, transmission and stop bands .

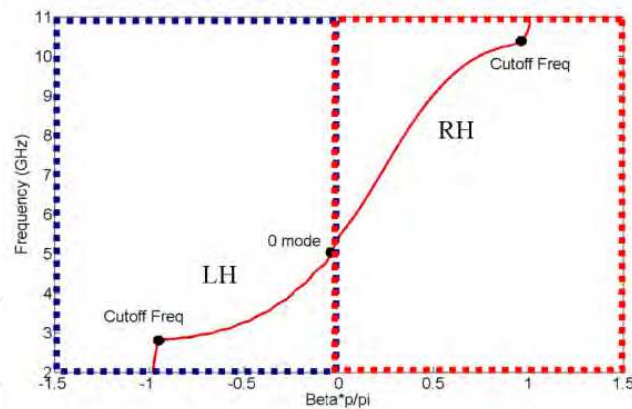
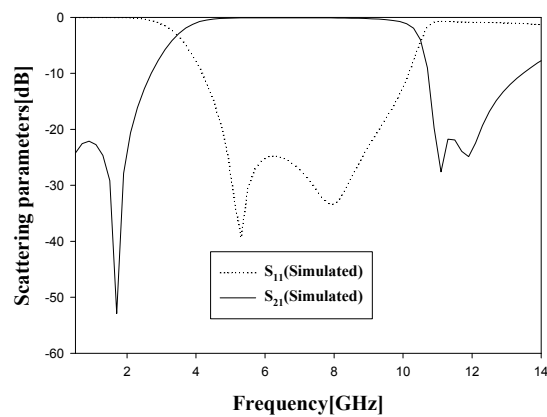
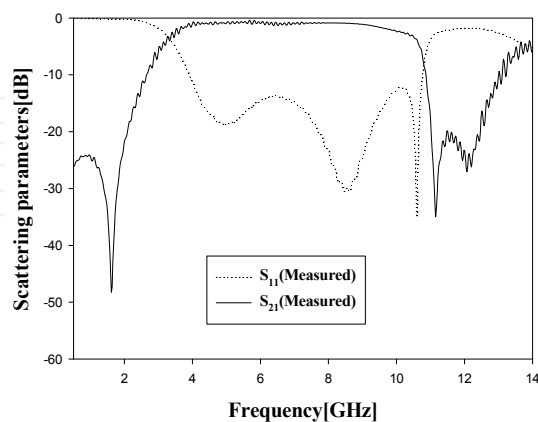

Fig. 2-5. Dispersion curve of the proposed UWB BPF

The refined physical dimensions based upon the initial values for the filter's geometry, the 3D EM full-wave simulation has been carried out.



(a)



(b)

Fig. 2-6. S_{11} and S_{21} of the proposed UWB BPF (a) Simulation (b) measurement.

Fig. 2-6 plots the simulated scattering parameters S_{11} and S_{21} verified by the measurement. Excellent agreement is shown between the simulated and measured S_{21} with almost the same transmission zeros, bandwidth over 100 % and insertion loss less than 1dB. Also, good return loss is given despite the small discrepancy guessed due to the mechanical tolerance error. Next, we need to check out the group-delay of the designed filter.

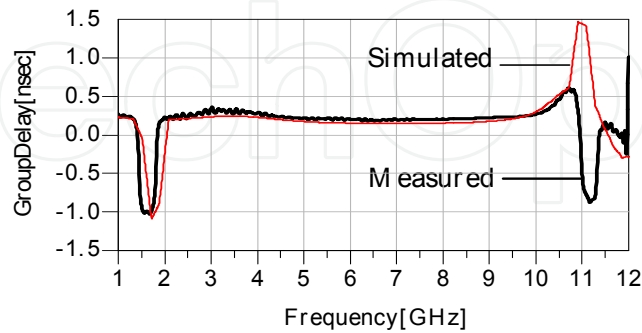

Fig.2- 7. Group-delay of the proposed UWB BPF : Simulation and measurement.

The variation of the group-delay is as small as less than 0.25 nsec over the passband. Lastly, we show the photograph of our fabricated UWB BPF.

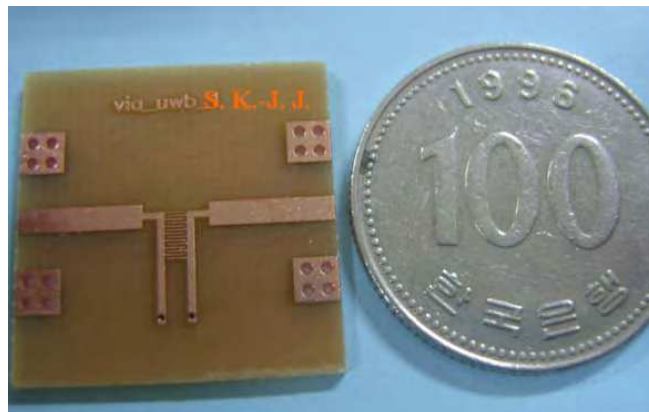

Fig. 2-8. Picture of the designed UWB BPF

The interdigital line sandwiched by the grounded stubs composes the proposed filter which is about 4.7 mm long (far less than a quarter guided-wavelength).

4. Conclusion

The A new compact UWB BPF is proposed using the concept of the CRLH-TL. Only 1 unit of the CRLH-TL is taken for enhanced size reduction and implemented with the interdigital line and grounded stubs with their effective parasitics for the UWB. The designed BPF performs with the BW over 100%, good insertion and return loss, and flat group-delay with the overall size to the guided wavelength/9.4.

5. Acknowledgment

This work was supported by the IT R&D program of MKE/IITA. [2009-S-001-01, Study of technologies for improving the RF spectrum characteristics by using the meta-electromagnetic structure]

6. References

- [1] Miodrag V. Gmitrovic et al, "Fixed and Variable Slope CATV Amplitude Equalizers," *Applied Microwave & Wireless*, Jan/Feb 1998, pp. 77-83.
- [2] M. Sankara Narayana, "Gain Equalizer Flattens Attenuation Over 6-18 GHz," *Applied Microwave & Wireless*, November/December 1998.
- [3] D.J.Mellor , "On the Design of Matched Equalizer of prescribed Gain Versus Frequency Profile". *IEEE MTT-S International Microwave Symposium Digest* , 1997, pp.308-311.
- [4] Broadband MIC Equalizers TWTA Output Response . *IEEE Design Feature*. Oct 1993
- [5] S. Kahng et al, "Expanding the bandwidth of the linear gain equalizer: Ku-band communication," *KEES Journal*, Vol. KEESJ18, No. 2, pp. 105-110, Feb. 2007.
- [6] H. Ishida, and K. Araki, "Design and Analysis of UWB Bandpass Filter with Ring Filter," in *IEEE MTT-S Intl. Dig.* June 2004 pp. 1307-1310.
- [7] H. Wang, L. Zhu and W. Menzel, "Ultra-Wideband Bandpass Filter with Hybrid Microstrip/CPW Structure," *IEEE Microwave And Wireless Components Letters*, vol. 15, pp. 844-846, December 2005
- [8] S. Sun, and L. Zhu, "Capacitive-Ended Interdigital Coupled Lines for UWB Bandpass Filters with Improved Out-of-Band Performances," *IEEE Microwave And Wireless Components Letters*, vol. 16, pp. 440-442, August 2006.
- [9] W. Menzel, M. S. R. Tito, and L. Zhu, "Low-Loss Ultra-Wideband(UWB) Filters Using Suspended Stripline," in *Proc. Asia-Pacific Microw. Conf.* , Dec. 2005, vol. 4, pp.2148-2151
- [10] C.-L. Hsu, F.-C. Hsu, and J.-T. Kuo, "Microstrip Bandpass Filters for Ultra-Wideband(UWB) Wireless Communications," in *IEEE MTT-S Intl. Dig.* , June 2005, pp.675-678
- [11] C. Caloz and T. Itoh, *Electromagnetic Metamaterials : Transmission Line Theory and Microwave Applications*, WILEY-INTERSCIENCE, John-Wiley & Sons Inc., Hoboken, NJ 2006
- [12] S. Kahng, and J. Ju, "Left-Handedness based Bandpass Filter Design for RFID UHF-Band applications," in *Proc. KJMW 2007*, Nov.. 2007, vol. 1, pp.165-168.
- [13] J. Ju and S. Kahng, "Design of the Miniaturized UHF Bandpass Filter with the Wide Stopband using the Inductive-Coupling Inverters and Metamaterials," in *Proc. Korea Electromagnetic Engineering Society Conference 2007*, Nov. 2007, vol. 1, pp.5-8
- [14] K. C. Gupta, R. Garg, I. Bahl, and P. Bhartia, *Microstrip Lines and Slotlines*, Artech House Inc., Norwood, MA 1996



Advanced Microwave and Millimeter Wave Technologies Semiconductor Devices Circuits and Systems

Edited by Moumita Mukherjee

ISBN 978-953-307-031-5

Hard cover, 642 pages

Publisher InTech

Published online 01, March, 2010

Published in print edition March, 2010

This book is planned to publish with an objective to provide a state-of-the-art reference book in the areas of advanced microwave, MM-Wave and THz devices, antennas and system technologies for microwave communication engineers, Scientists and post-graduate students of electrical and electronics engineering, applied physicists. This reference book is a collection of 30 Chapters characterized in 3 parts: Advanced Microwave and MM-wave devices, integrated microwave and MM-wave circuits and Antennas and advanced microwave computer techniques, focusing on simulation, theories and applications. This book provides a comprehensive overview of the components and devices used in microwave and MM-Wave circuits, including microwave transmission lines, resonators, filters, ferrite devices, solid state devices, transistor oscillators and amplifiers, directional couplers, microstripeline components, microwave detectors, mixers, converters and harmonic generators, and microwave solid-state switches, phase shifters and attenuators. Several applications area also discusses here, like consumer, industrial, biomedical, and chemical applications of microwave technology. It also covers microwave instrumentation and measurement, thermodynamics, and applications in navigation and radio communication.

How to reference

In order to correctly reference this scholarly work, feel free to copy and paste the following:

Sungtek Kahng (2010). Ultrawideband Bandpass Filter Using Composite Right- and Left-Handedness Line Metamaterial Unit-Cell, *Advanced Microwave and Millimeter Wave Technologies Semiconductor Devices Circuits and Systems*, Moumita Mukherjee (Ed.), ISBN: 978-953-307-031-5, InTech, Available from: <http://www.intechopen.com/books/advanced-microwave-and-millimeter-wave-technologies-semiconductor-devices-circuits-and-systems/ultrawideband-bandpass-filter-using-composite-right-and-left-handedness-line-metamaterial-unit-cell>

INTECH
open science | open minds

InTech Europe

University Campus STeP Ri
Slavka Krautzeka 83/A
51000 Rijeka, Croatia
Phone: +385 (51) 770 447
Fax: +385 (51) 686 166

InTech China

Unit 405, Office Block, Hotel Equatorial Shanghai
No.65, Yan An Road (West), Shanghai, 200040, China
中国上海市延安西路65号上海国际贵都大饭店办公楼405单元
Phone: +86-21-62489820
Fax: +86-21-62489821

www.intechopen.com

www.intechopen.com

IntechOpen

IntechOpen

© 2010 The Author(s). Licensee IntechOpen. This chapter is distributed under the terms of the [Creative Commons Attribution-NonCommercial-ShareAlike-3.0 License](#), which permits use, distribution and reproduction for non-commercial purposes, provided the original is properly cited and derivative works building on this content are distributed under the same license.

IntechOpen

IntechOpen