

# We are IntechOpen, the world's leading publisher of Open Access books Built by scientists, for scientists

**4,800**

Open access books available

**122,000**

International authors and editors

**135M**

Downloads

Our authors are among the

**154**

Countries delivered to

**TOP 1%**

most cited scientists

**12.2%**

Contributors from top 500 universities



**WEB OF SCIENCE™**

Selection of our books indexed in the Book Citation Index  
in Web of Science™ Core Collection (BKCI)

Interested in publishing with us?  
Contact [book.department@intechopen.com](mailto:book.department@intechopen.com)

Numbers displayed above are based on latest data collected.

For more information visit [www.intechopen.com](http://www.intechopen.com)



# Sensors Characterization and Control of Measurement Systems Based on Thermoresistive Sensors via Feedback Linearization

M. A. Moreira<sup>1</sup>, A. Oliveira<sup>2</sup>, C.E.T. Dórea<sup>2</sup>, P.R. Barros<sup>3</sup>  
and J.S. da Rocha Neto<sup>3</sup>

<sup>1</sup> Universidade Estadual de Campinas

<sup>2</sup> Universidade Federal da Bahia

<sup>3</sup> Universidade Federal de Campina Grande  
Brazil

## 1. Introduction

In this work the application of feedback linearization to characterize thermoresistive sensors and in feedback measurement systems which uses this kind of sensors, is presented.

Thermoresistive sensors, in the general sense, are resistive sensors which work based on the variation of an electrical quantity (resistance, voltage or current) as a function of a thermal quantity (temperature, thermal radiation or thermal conductance). An important application of thermoresistive sensors is in temperature measurement, used in different areas, such as meteorology, medicine and motoring, with different objectives, such as temperature monitoring, indication, control and compensation (Pallas-Areny & Webster, 2001), (Doebelin, 2004), (Deep et al., 1992).

Temperature measurement is based upon the variation of electrical resistance. In this case heating by thermal radiation or self-heating by Joule effect may be null or very small so that the sensor temperature can be considered almost equal to the temperature one wants to measure (contact surface temperature, surround temperature, the temperature of a liquid, etc.).

A successful method for measurement using thermoresistive sensor uses feedback control to keep the sensor temperature constant (Sarma, 1993), (Lomas, 1986). Then, the value of the measurand is obtained from the variation of the control signal. This method inherits the advantages of feedback control systems such as low sensitivity to changes in the system parameters (Palma et al., 2003).

A phenomenological dynamic mathematical model for thermistors can be obtained through the application of energy balance principle. In such a model, the relationship between the

excitation signal (generally electrical voltage or current) and the sensor temperature is nonlinear (Deep et al., 1992), (Lima et al., 1994), (Freire et al., 1994). That results in two major difficulties:

- The static and dynamic characterization of the sensor has to be done through two different experimental tests,
- Performance degradation of the feedback control system as the sensor temperature drifts away from that considered in the controller design.

As an alternative to circumvent such difficulties, the present work proposes the use of feedback linearization. This technique consists in using a first feedback loop to linearize the relationship between a new control input and the system output (Middleton & Goodwin, 1990). Then, a linear controller can be designed which delivers the desired performance over all the operation range of the system. Here, feedback linearization is used in measurement systems based on thermoresistive sensors, allowing for:

- Sensor characterization using a single experimental test,
- Suitable controller performance along the whole range of sensor temperatures.

The Section 2 presents the fundamentals of measurement using thermoresistive sensors. In Section 3, the experimental setup used in this work is described. In Section 4 it is presented the proposed feedback linearization together with the related experimental results. Finally, in Section 5 the control design and the related experimental result are discussed, which attest the effectiveness of the proposed technique.

## 2. Measurement Using Thermoresistive Sensors

### 2.1 Mathematical model

The relationship between temperature and electrical resistance of a thermoresistive sensor depends on the kind of sensor, which can be a resistance temperature detector - *RTD* or a thermistor (thermally sensitive resistor). Details of construction and description about the variation in electrical resistance can be found, for example, in (Asc, 1999), (Meijerand & Herwaarden, 1994).

For a *RTD* the variation in electrical resistance can be given by:

$$R_S = R_0(1 + \alpha_1(T_S - T_0) + \alpha_2(T_S - T_0)^2 + \dots + \alpha_n(T_S - T_0)^n) \quad (1)$$

where  $R_0$  is the resistance at the reference temperature  $T_0$  and  $\alpha_0$  are temperature coefficients.

For a *NTC* (Negative Coefficient Temperature) thermistor the variation in electrical resistance can be given by:

$$R_S = R_0 e^{B(1/T_S + 1/T_0)} \quad (2)$$

where  $R_0$  is the resistance at the reference temperature  $T_0$ , in Kelvin, and  $B$  is called the characteristic temperature of the material, in Kelvin.

For some thermoresistive sensor not enclosed in thick protective well, the equation of energies balance (the relationship of incident thermal radiation, electrical energy, the dissipated and stored heat) can be given by:

$$\alpha SH + P_s(t) = G_{th}[T_s(t) - T_a(t)] + C_{th} \frac{dT_s(t)}{dt} \quad (3)$$

where:

$\alpha$  is the sensor transmissivity-absorptivity coefficient,

$S$  is the sensor surface area,

$H$  is the incident radiation,

$P_s(t)$  is the electric power,

$G_{th}$  is the thermal conductance between sensor and ambient,

$T_a(t)$  is the ambient temperature,

$C_{th}$  is the sensor thermal capacity,

At the static equilibrium condition ( $dT_s(t) / dt = 0$ ) the (Eq. 3) reduces to:

$$\alpha SH + P_e = G_{th}(T_s - T_a) \quad (4)$$

In experimental implementations it is common to use voltage or electric current as the excitation signal, as it is not possible to use electric power directly. Using electric current:

$$P_s(t) = R_s(T_s(t))I_s^2(t) \quad (5)$$

and considering the ambient temperature  $T_a$ , constant, (Eq. 3) can be rewritten as:

$$\alpha SH + R_s(T_s(t))I_s^2(t) = G_{th}T_\Delta(t) + C_{th} \frac{dT_\Delta(t)}{dt} \quad (6)$$

where  $T_\Delta(t) = T_s(t) - T_a$ .

Temperature measurement is based upon the variation of electrical resistance (Eq. 1 or Eq.2).

The measurement of thermal radiation ( $H$ ) or fluid flow velocity (fluid flow velocity related to  $G_{th}$  variation) is based on (Eq. 4). With the sensor supplied by a constant electrical current, or kept at constant resistance (and temperature), the measurement is based on the variation in the sensor voltage.

The thermoresistive sensor used in this research is a *NTC* (Negative Coefficient Temperature).

For  $S$ ,  $G_{th}$  and  $C_{th}$  constant, (Eq. 3) is a first order linear differential equation with variable  $T_s(t)$  and excitations  $H$ ,  $T_a(t)$  and  $P_S(t)$ . In experimental implementations it is common to use voltage or electric current as excitation signal of the sensor (it is not possible to use electric power directly), and the electrical power is done by  $V_S \times I_S$ ,  $R_S \times I_S^2$  or  $V^2 / R_S$ . In this case, (Eq. 3) becomes a nonlinear differential equation (Eq. 6) and causes difficulties for the characterization of the sensor (determination of  $G_{th}$  and  $C_{th}$ ) with electrical signal, and for the measurement of thermal radiation.

## 2.2 Sensor Characterization

Usually the characterization of a thermoresistive sensor is done by combination of three experimental tests. In the first experimental test the parameters of the equation associating electrical resistance and temperature are determined (Eq. 1 or Eq. 2). The other experimental tests are for the determination of  $G_{th}$  e  $C_{th}$  (Eq. 3).

The parameters of (Eq.1) and (Eq.2) are given from de measurement of the electrical resistance at fixed temperatures, (0.01 °C - triple point of water and 100 °C - boiling water), or with the sensor in an equipment with adjustment and control of temperature. In this experimental test the heating by thermal radiation or self-heating by Joule effect may be null or very small. The result of the first experimental test is employed in the other two, for the determination of sensor temperature.

For the second experimental test, the sensor is immersed in a fluid medium (air, water, etc), where one wants to determine  $G_{th}$ . The temperature of this medium is kept constant and the sensor is heated by Joule effect, supplied by a constant electrical current with values  $I_i$  ( $i = 1$  to  $n$ ). In the condition of static thermal equilibrium ( $dT_S/dt = 0$ ) the equivalent voltages,  $V_i$ , of the sensor are measured. With the values of  $I_i$  e  $V_i$ , the values of  $R_{Si}$ ,  $T_{Si}$  e  $P_{Si}$  e  $(T_{Si} - T_a)$  are determined. The value of  $G_{th}$  is then determined by curve fitting from the values of  $P_{Si}$  and  $(T_{Si} - T_a)$ . With low accuracy the value of  $G_{th}$  can be determined from only two points.

In the third experimental test the sensor electric resistance is measured during a given time interval. The values of the sensor temperature, during this time interval, are determined from the resistance values, and then the time constant is calculated  $\tau = C_{th}/G_{th}$ . The variation of the sensor temperature is done by a step of electrical signal or of medium temperature.

By application of a step in the electrical signal, the sensor is maintained in the medium of the previous test and heated by a constant electrical current, reaching a temperature higher than that of the medium. When the electrical current is reduced to zero at instant  $t_0$  (negative step), the temperature of the sensor ( $T_S$ ) falls exponentially from a temperature  $T_0$  to the temperature  $T_a$  of the medium, according to:

$$T_S = T_a + (T_0 - T_a)e^{-(t-t_0)/\tau} \quad (7)$$

Through a step of medium temperature, the sensor is initially maintained in the environment temperature and, at instant  $t_0$ , it is suddenly immersed in the fluid of the second experimental test with temperature higher than that of the environment.

The sensor temperature changes exponentially from  $T_0$  (environmental temperature) to  $T_a$  (temperature of the fluid), with:

$$T = T_a - (T_a - T_0)e^{-(t-t_0)/\tau} \quad (8)$$

The equations (Eq. 7) and (Eq. 8) are particular solutions of (Eq. 3) with  $H = 0$ , and the time constant,  $\tau$ , may be determined by curve fitting or from the falling (rising) time. As shown in the sequel, with feedback linearization  $G_{th}$  and  $C_{th}$  can be determined from a single experimental test.

### 2.3 Methods of Measurement

Considering the measuring operations, the measurement methods can be classified as: substitution or deflection methods; difference methods and null methods (Klaassen, 1996), (Tse & Morse, 1989).

The substitution method uses a single transformation from the value of the measurand to the value of the measuring variable, as, e.g. the temperature measurement with clinic thermometer where temperature of a patient is transformed into the expansion of the liquid in the thermometer.

In the difference method the measuring variable is related to the difference between an unknown quantity and a known reference quantity as, e.g. in the measurement of temperature with *RTD* in a Wheatstone bridge.

In the null method, the unknown value of the measurand is compared with a known reference quantity. A well known example is the balance, where an unknown mass is put on one extremity and a known mass is put on the other extremity until the equilibrium of the balance is reached (null). Another example is resistance measurement using Wheatstone bridge. In these two examples, feedback is provided by the operator.

The method employed in feedback measurement system can be considered as a null method, where a quantity of the system is automatically set to a reference value (equilibrium value) by the variation of the measure variable. This method preserves some known properties of a feedback system, like the reduction of the time constant (or response time) and of the nonlinear behavior, as well as enlargement of frequency pass band.

In measurement with thermoresistive sensor excited by a constant current, a variation in the value of the measurand (thermal radiation or fluid flow velocity) causes a variation in the sensor voltage. This method is known as constant current method and may be classified as a substitution method.

Another possible method is the so-called constant temperature method. In this case, the electrical resistance of the sensor is kept constant by feedback. A variation of the value of the measurand is compensated by a variation of the sensor voltage or electrical current (and indirectly the electrical power) to keep the electrical resistance in a constant reference value.

### 3. Experimental Setup

The experimental setup developed for tests, characterization and control of the sensor temperature is shown in Fig. 1. The block *ambient with sensor* refers to a closed housing where the sensor is kept. Hence, the incident radiation on the sensor surface is null ( $H=0$ ). The internal temperature is monitored by a thermometer in this housing.

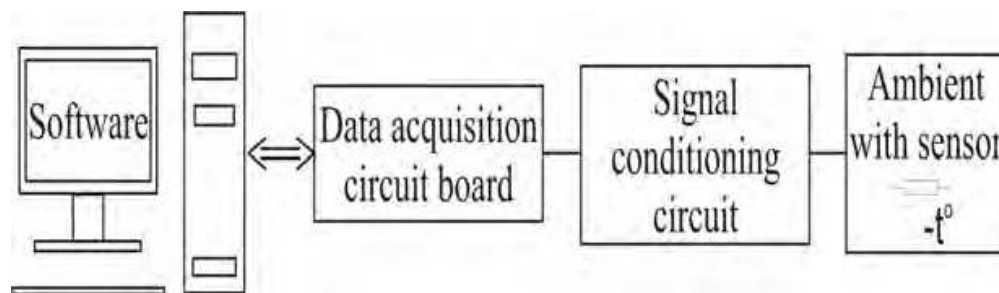

Fig. 1. Block diagram of experimental setup.

The *signal conditioning circuit* (Fig. 2) is intended to: provide the electrical decoupling between the data acquisition system and the sensor, adjust the DAC sensor excitation signal and adjust the sensor output signal to the ADC input requirements.

In this paper, the thermoresistive sensor circuit is highlighted to simplify the theoretical analysis (Fig. 3). The *data acquisition circuit board* is the PCI6024E, produced by National Instruments, and the man-machine interface is developed on LABVIEW. A virtual instrument was designed with this software, where a set of control functions allows quickly change the main program, insuring high flexibility on computer programming.

The manufacturer furnishes a table relating electrical resistance and temperature for the NTC used. This way, the values of the parameters ( $A=R_0 \exp(-B/T_0)$ ) and  $B$  could be calculated from (Eq. 2):  $A=1354.06e^{-5}\Omega$ ;  $B=3342.21K$ . These parameters characterize the static behaviour of the sensor. The feedback linearization developed in the present work makes possible to determine the dynamic parameter (time constant,  $\tau$ ) and another static parameter (DC gain,  $G_{th}$ ) in a single test.



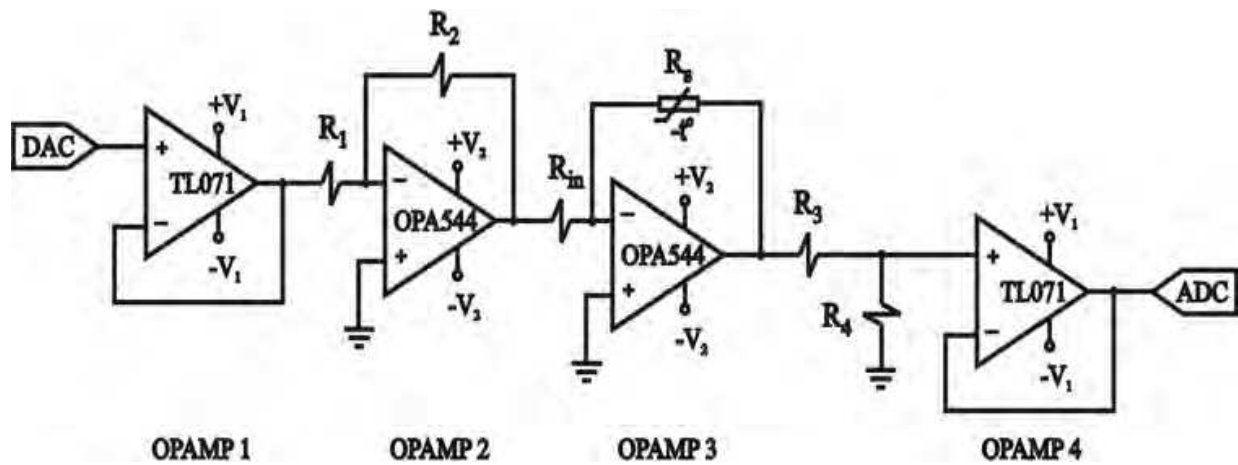

Fig. 2. Developed electronic circuit schematics

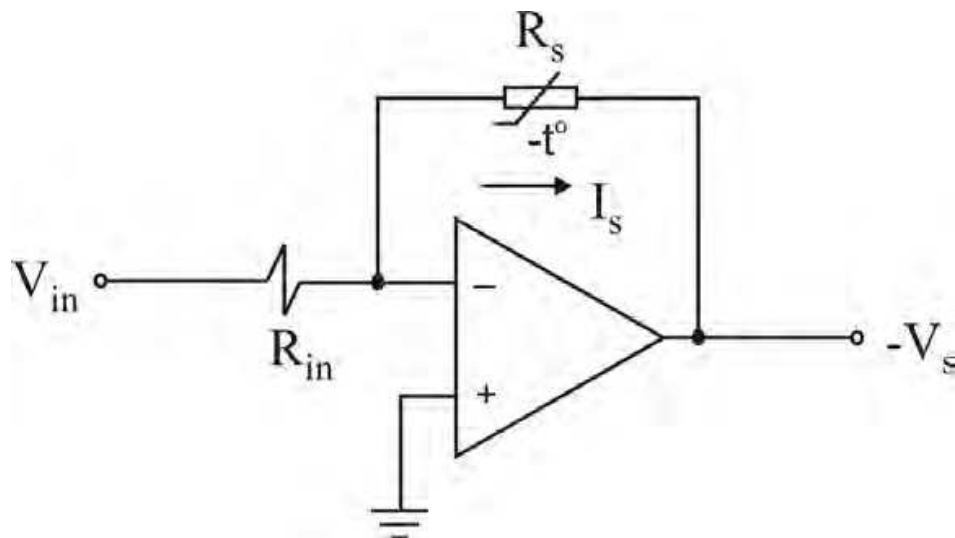

Fig. 3. Electronic sub-circuit.

## 4. Feedback Linearization

### 4.1 Theoretical Development

The proposed feedback linearization scheme is shown in Fig. 4. From this figure one can deduce:

$$I_s(t) = \frac{V_{in}(t)}{R_{in}} \quad (9)$$

$$V_{in}(t) = \frac{a(t)}{b(t)} = \frac{a(t)}{V_s(t)} \quad (10)$$



From (Eq. 9) and (Eq. 10),

$$P_s(t) = V_s(t)I_s(t) = \frac{a(t)}{R_{in}} \quad (11)$$

In this case,  $a(t)$  is a virtual variable that is equivalent to the electric power dissipated by the sensor multiplied by the value of  $R_{in}$ . It is necessary to define a new input variable ( $P_x(t)$ ) to distinguish this virtual product from the real electric power:

$$P_x(t) = \frac{a(t)}{R_{in}} \quad (12)$$

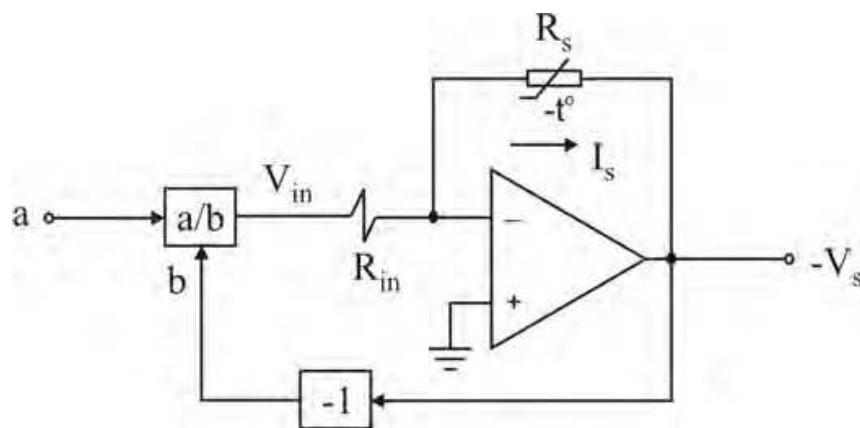

Fig. 4. Electronic sub-circuit with feedback linearization.

Considering null the incident radiation ( $H=0$ ), assuming constant the ambient temperature, and adopting the new input variable defined in (Eq.12), (Eq.1) can be rewritten as:

$$P_x(t) = G_{th}T_{\Delta}(t) + C_{th} \frac{dT_{\Delta}(t)}{dt} \quad (13)$$

From this equation one can note that the feedback system is linear with respect to the new input variable  $P_x(t)$ . The transfer function in the linearized system (applying the Laplace Transform) in (Eq. 13) is a first order function:

$$\frac{T_{\Delta}(s)}{P_x(s)} = \frac{1/G_{th}}{\frac{C_{th}}{G_{th}}s + 1} \quad (14)$$

## 4.2. Experimental results

The sensor response (Eq. 14) to a constant power  $P_{cte}$  is given by:

$$T_{\Delta}(t) = \frac{P_{cte}}{G_{th}} (1 - e^{-t/\tau}) \quad (15)$$

where  $\tau = C_{th}/G_{th}$ .

An increasing stair signal with 100s per step (to guarantee that the sensor would be operating in steady state) was applied to both systems: without feedback linearization (non-linearized system), and with feedback linearization (linearized system). The responses are shown in Fig. 5 and Fig. 6.

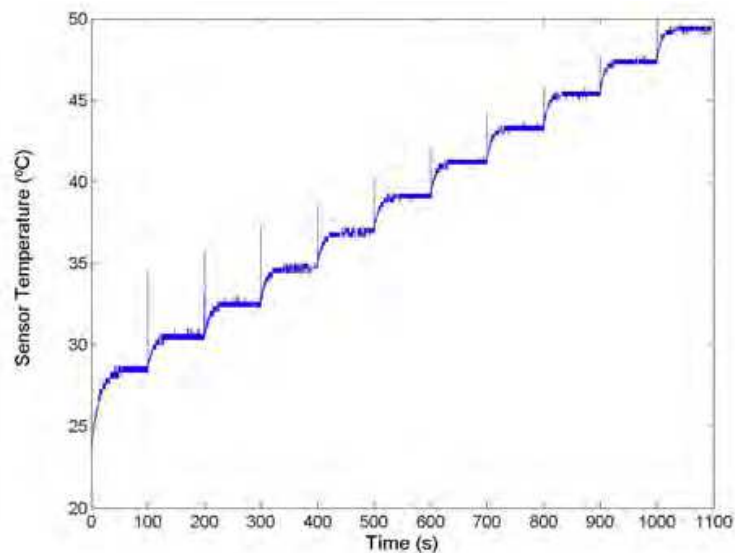

Fig. 5. Output temperature with input in increasing steps (non-linearized system).

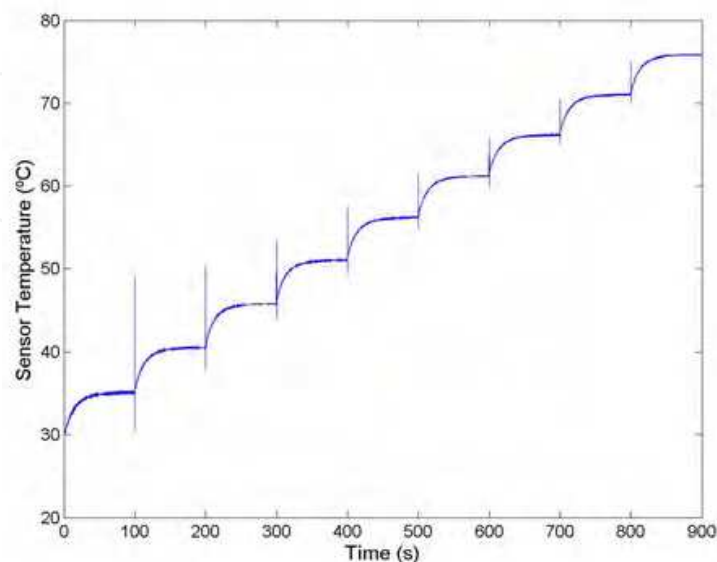

Fig. 6. Output temperature with input in increasing steps (linearized system).

The relation  $T/P_{cte}$  changes when the systems works at different operation points in the non-linearized systems. This time constant is called apparent ( $\tau_a$ ), and it does not correspond to the intrinsic time constant of the sensor ( $\tau$ ). The DC gain ( $G_{th}$ ) is given by:

$$G_{th} = \frac{\overline{P_x}}{\overline{T_\Delta}} \quad (16)$$

where  $\overline{P_x}$  and  $\overline{T_\Delta}$  are the electrical power and the temperature difference in steady state, respectively.

The results for the static parameter ( $G_{th}$ ) and dynamic parameter ( $\tau$ ) for both systems are presented in Table 1. In conclusion, for linearized systems it is possible to determine the static and dynamic behaviours with a single set of experimental data.

Step	Non-linearized		Linearized	
	$G_{th}$ (mW/°C)	$\tau_a$ (s)	$G_{th}$ (mW/°C)	$\tau$ (s)
1	0.80	14.3	1.56	12.0
2	0.80	12.4	1.40	11.3
3	0.82	11.1	1.30	11.3
4	0.80	10.6	1.29	11.3
5	0.81	10.1	1.26	11.6
6	0.82	9.5	1.24	11.4
7	0.83	9.2	1.22	11.5
8	0.81	9.1	1.21	11.4
9	0.81	8.1	1.19	11.7
10	0.82	8.5	-	-
11	0.82	7.8	-	-

Table 1. DC gain and time constant in non-linearized and linearized systems.

## 5. Control Design

### 5.1 Internal Model Control

The control objective is to make the temperature reach and stay in the setpoint as quick as possible. In this sense, the effects of external disturbances and variations at system parameters should be efficiently attenuated. The *IMC* (*Internal Model Control*) control design has the advantage of considering the internal model of the process. By assuming that the system operates in a closed-loop form, this control strategy makes it possible to mitigate the influence of variations and disturbances cited above.

The adopted *IMC* structure is shown in Fig. 7.

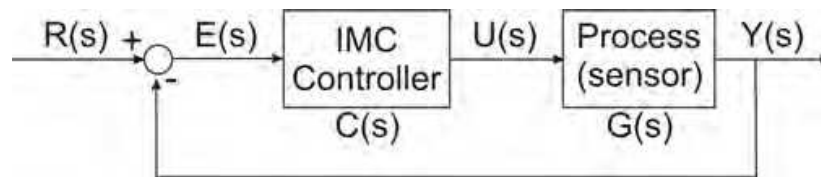

Fig. 7. IMC control structure arranged like a conventional feedback structure.

It turns out that for a simple first order linear system, the IMC controller results in a PI controller whose zero cancels the open-loop pole, i.e.

$$C(s) = K_P + \frac{K_I}{s} = K_P \frac{s + (K_I / K_P)}{s} \quad (17)$$

so that, by choosing  $K_P = C_{th} / \tau_f$  and  $K_I = G_{th} / \tau_f$  (where  $\tau_f$  is the time constant of the IMC low pass filter), one has:

$$C(s)G(s) = \frac{C_{th}s + G_{th}}{\tau_f s} \frac{1}{C_{th}s + G_{th}} = \frac{1}{\tau_f s} \quad (18)$$

and the following closed loop transfer function:

$$\frac{Y(s)}{R(s)} = \frac{1}{\tau_f s + 1} \quad (19)$$

## 5.2. Experimental results

To compare the performance of linearized and non-linearized systems, two PI controllers have been implemented: one for each system. For the non-linearized system, a linear approximation around a specific operation point (70°C) has been made. The results for the following test conditions are presented:

- (i) Setpoint increasing by five steps of 10°C, varying from 50°C up to 90°C, step duration of 60s, closed loop time constant=5s (Fig. 8);
- (ii) Single setpoint by single step (70°C), duration of 60s, closed loop time constant=5s (Fig. 9).

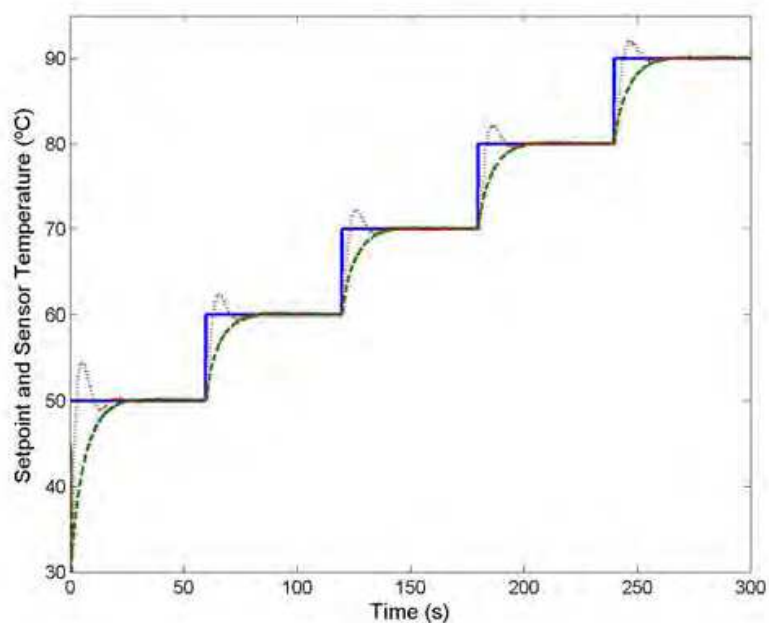

Fig. 8. Setpoint in increasing steps (continuous line), output of linearized system (dashed line) and output of non-linearized system (dotted line) with closed loop time constant=5s

It can be seen that both controllers could drive the temperature to the setpoint. However, in the non-linearized system overshoot occurs for all temperature steps, as well as for the designed operation point. Similar behaviour is observed in (Palma et al., 2003).

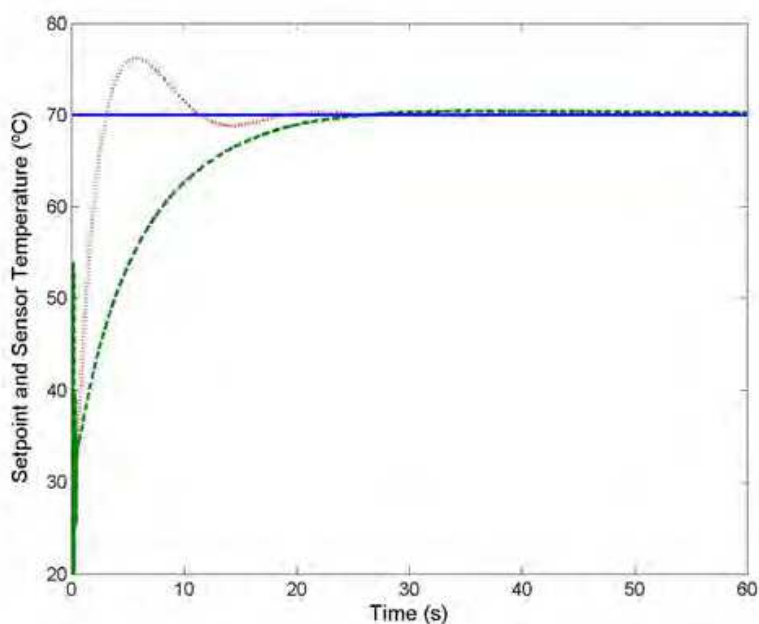

Fig. 9. Setpoint (continuous line), output of linearized system (dashed line) and output of non-linearized system (dotted line) with closed loop time constant=5s

Considering the linearized system, by adjusting the system response curves using the least squares method, for each temperature step (Fig. 8), it was possible to calculate the time constants for each step. These values are shown on Table 2.

Setpoint (°C)	Time constant (s)	Variation of time constant projected (%)
50	4.48	-10.4
60	5.41	+8.2
70	5.78	+15.6
80	5.92	+18.4
90	6.00	+20.0

Table 2. Calculated time constant for linearized system with setpoint in increasing steps and designed closed loop time constant for 5s.

Other different tests of the controller using several closed-loop time constants have been done. The system behaves similarly as for the 5s time constant. The results for the closed time loop constant designed for 0.5s are shown in Fig. 10, Fig. 11 and Table 3. The tests conditions are:

- (i) Setpoint increasing by five steps of 10°C, varying from 50°C up to 90°C, step duration of 10s (Fig. 10);
- (ii) Single setpoint by single step (50°C), duration of 10s, (Fig. 11).

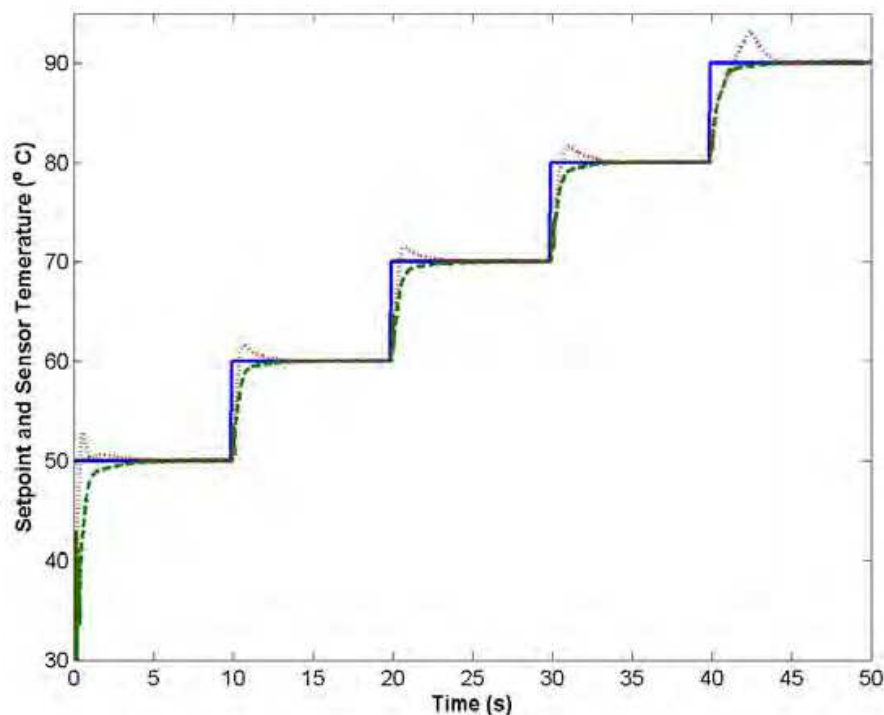

Fig. 10. Setpoint in increasing steps (continuous line), output of linearized system (dashed line) and output of non-linearized system (dotted line) with closed loop time constant=0.5s

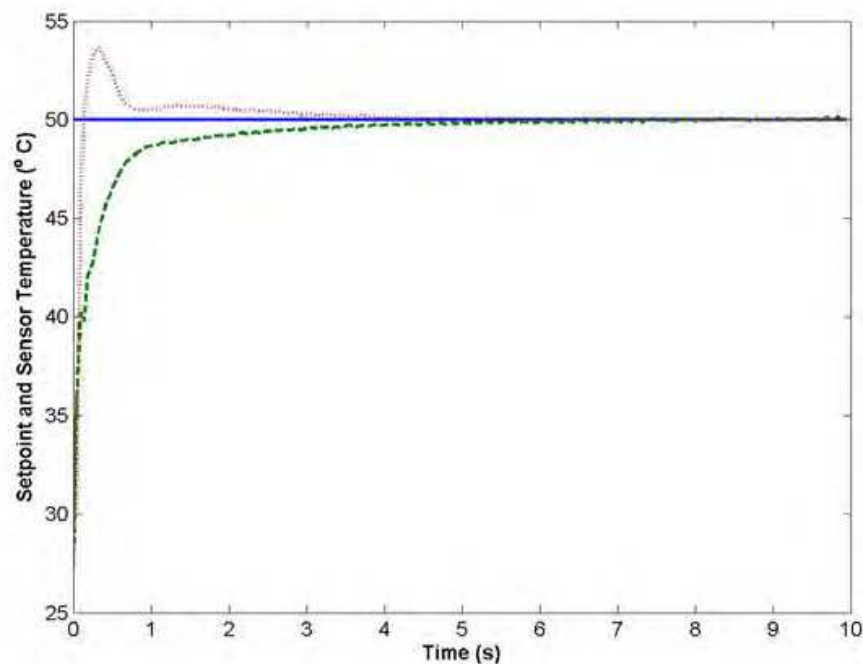

Fig. 11. Setpoint (continuous line), output of linearized system (dashed line) and output of non-linearized system (dotted line) with closed loop time constant equal to  $0.5s$

Setpoint (°C)	Time constant (s)	Variation of time constant projected (%)
50	0.44	-12
60	0.45	-10
70	0.47	-6
80	0.48	-4
90	0.55	+10

Table 3. Calculated time constant for linearized system with setpoint in increasing steps and designed closed loop time constant for  $0.5 s$ .

Variations between the designed and the calculated time constants have been observed. Some of the reasons for this difference could be:

- (i) The expected pole-zero cancellation from the project of *IMC* controller is not precise;
- (ii) The determination of the time constant depends on a curve fitting.

## 6. Conclusions

In this work, the direct use of electrical power as excitation parameter is proposed. This is due to the feedback linearization applied to the system, which also contributes for the characterization of sensor parameters in a single set of experimental test.



The *PI* controller designed by *IMC* technique was able to meet the imposed performance requirements. The results for the linearized system showed to be better when compared to the nonlinearized system, as the model used in the design is valid for all the operation range.

As perspective for future works it could be mentioned:

- (i) The use of feedback linearization to characterize other kinds of thermoresistive sensors;
- (ii) The application of another control strategy in combination with feedback linearization;
- (iii) The use of the measurement system developed to measure physical variables.

## 7. References

- Asch, G. *Les capteurs en instrumentation industrielle*, 5th ed., Dunod, 1999, chap. 6 - Capteurs de température.
- Deep, G.S., R. C. S. Freire, P. C. Lobo, J. S. da Rocha Neto, A. M. N. Lima, "Dynamic response of thermoresistive sensors", *IEEE Transactions on Instrumentation and Measurement*, n° 6, pp. 815-819, 1992.
- Doebelin, E.O. *Measurements systems: application and design*, McGraw Hill, 2004.
- Fransis S. Tse & Ivan E. Morse, *Measurement and Instrumentation in Engineering*, Marcel Dekker, Inc.1989.
- Freire, R.C.S., J. S. da Rocha Neto, G. S. Deep, A. M. N. Lima, P. C. Lobo, "Experimental determination of the time constant of a thermoresistive sensor", *IEEE Instrumentation and Measurement Technology Conference (IMTC'94)*, pp. 450-453, 1994.
- Klaas B. Klaassen, *Electronic Measurement and Instrumentation*, Cambridge University Press, 1996.
- Lima, A.M.N., G. S. Deep, J. S. da Rocha Neto, R. C. S. Freire, P. C. Lobo, "Identification of thermoresistive solar radiation sensors", *IEEE Transactions on Instrumentation and Measurement*, n° 2, pp. 133-138, 1994.
- Lomas, C.G. *Fundamentals of hot wire anemometry*, Cambridge University Press, 1986.
- Meijerand A. W. Herwaarden, *Thermal Sensors*, IOP Publishing Ltda, 1994, cap. 4 - Temperature-sensing Elements.
- Middleton, R.H. & G. C. Goodwin, *Digital control and estimations - an unified approach*, Prentice Hall, 1990.
- Pallas-Areny, R & J. G. Webster, *Sensors and signal conditioning*, John Wiley and Sons Ltd, 2001.
- Palma, L.S., A. Oliveira, A. S. da Costa, A. Q. Andrade Jr., C. V. R. de Almeida, M. Zurita and R. C. S. Freire, "Implementation of a feedback I2-controlled constant temperature environment temperature meter", *Sensors*, n° 10, pp. 498-503, 2003.
- Sarma, G.R. "Analysis of a constant voltage anemometer circuit", *IEEE Instrumentation and Measurement Technology Conference (IMTC'93)*, pp. 731-736, 1993.

IntechOpen

IntechOpen



## **Advances in Measurement Systems**

Edited by Milind Kr Sharma

ISBN 978-953-307-061-2

Hard cover, 592 pages

**Publisher** InTech

**Published online** 01, April, 2010

**Published in print edition** April, 2010

### **How to reference**

In order to correctly reference this scholarly work, feel free to copy and paste the following:

M. A. Moreira, A. Oliveira, C.E.T. Dorea, P.R. Barros and J.S. da Rocha Neto (2010). Sensors Characterization and Control of Measurement Systems Based on Thermoresistive Sensors via Feedback Linearization, Advances in Measurement Systems, Milind Kr Sharma (Ed.), ISBN: 978-953-307-061-2, InTech, Available from: <http://www.intechopen.com/books/advances-in-measurement-systems/sensors-characterization-and-control-of-measurement-systems-based-on-thermoresistive-sensors-via-fee>

# **INTECH**

open science | open minds

### **InTech Europe**

University Campus STeP Ri  
Slavka Krautzeka 83/A  
51000 Rijeka, Croatia  
Phone: +385 (51) 770 447  
Fax: +385 (51) 686 166  
[www.intechopen.com](http://www.intechopen.com)

### **InTech China**

Unit 405, Office Block, Hotel Equatorial Shanghai  
No.65, Yan An Road (West), Shanghai, 200040, China  
中国上海市延安西路65号上海国际贵都大饭店办公楼405单元  
Phone: +86-21-62489820  
Fax: +86-21-62489821

INTECHOPEN

© 2010 The Author(s). Licensee IntechOpen. This chapter is distributed under the terms of the [Creative Commons Attribution-NonCommercial-ShareAlike-3.0 License](#), which permits use, distribution and reproduction for non-commercial purposes, provided the original is properly cited and derivative works building on this content are distributed under the same license.

IntechOpen

IntechOpen