

We are IntechOpen, the world's leading publisher of Open Access books Built by scientists, for scientists

5,300

Open access books available

130,000

International authors and editors

155M

Downloads

Our authors are among the

154

Countries delivered to

TOP 1%

most cited scientists

12.2%

Contributors from top 500 universities



WEB OF SCIENCE™

Selection of our books indexed in the Book Citation Index
in Web of Science™ Core Collection (BKCI)

Interested in publishing with us?
Contact book.department@intechopen.com

Numbers displayed above are based on latest data collected.

For more information visit www.intechopen.com



Solar Power Source for autonomous sensors

José Pelegrí-Sebastiá, Rafael Lajara Vizcaíno and Jorge Alberola Lluch
*Universitat Politècnica de Valencia
Spain*

1. Introduction

This chapter focuses on solar power source for autonomous sensors. Nowadays, low power consumption is assuming the main role in the design of embedded electronic devices or battery powered devices, mainly in wireless sensor networks (WSN) 0. In fact the power consumption of current wireless transceivers IC's is going down until such levels that take us to explore the application of renewable energies for autonomous powered wireless sensor networks, that turned out inefficient or not enough efficient up to now. Several articles discuss about the amount of energy that can be obtained from many environmental energies (Raghunathan et al., 2005; Roundy et al., 2004), (Park et al., 2004; Hande et al., 2006; Chou et al., 2005; Raghunathan et al., 2005; Kansal et al., 2004; Alberola et al., 2008) and it seems sunlight is the most powerful energy available at the probable location of a wireless sensor network outdoors. Currently, small solar panels deliver enough power for both charging batteries and supplying power to these low power wireless nodes (Arms et al., 2005; Rahimi et al., 2003; Hsu et al., 2005). Therefore, the main trade-offs that involve the design of an inexhaustible power source are not only taking care of getting a lot of energy from the solar panel, but mainly taking care of holding-up the stored energy. Thus, a careful selection of the electronic components in the power management circuit is essential to reach high efficiency at really low currents. Furthermore, the designer has to have in mind that batteries suffer the aging problem, by which they can reduce dramatically their capacity in two or three years if they are recharged daily. This chapter focuses on the practical application to automatically manage the sunlight energy and store it efficiently, while minimizing the strain on the storage components to extend the power source lifetime.

2. Background and related work

Most of solar powered devices with backup system are composed by a solar panel, a charging control unit and a single battery backup element (Dreher et al., 2004; Panasonic, 1999). Unfortunately the aging problem is always patent in batteries. Hence, the design of a real inexhaustible power source must take care of it by using storage elements without almost fatigue, like supercapacitors. As it is described in (Jiang et al., 2005), "Prometheus" use a system architecture with two energy buffers, two supercapacitors and a Li+ Battery. There, a electronic system as a microcontroller controls the recharging cycles of the battery and selects the energy path to the load by means of a switch. This architecture is strongly

dependent of the microcontroller, these supervises the switching at the right voltage threshold. Working at low rate duty cycles (among sleeping and working time), typically in network sensors, the wake-up of the microcontroller could be too delayed to switch the backup battery on time. This way, the system could lose the voltage supply and do not wake-up anymore. On the other hand, the consumption of an active microcontroller supervising the stored energy in the supercapacitors at high rate duty cycles could be comparable to the consumption of the current micro power supervisors IC's working at full time, but assuring a safe backup switching.

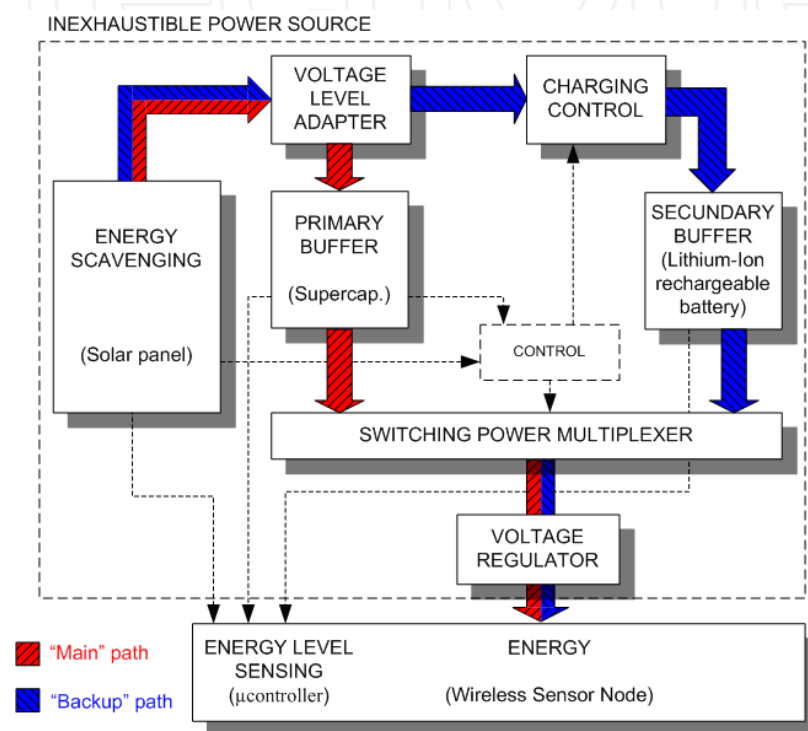

Fig. 1. Block diagram of the system architecture with the "Main" and "Backup" paths.

Therefore we evaluate a new system architecture that is shown in Figure 1, which is entirely independent of the microcontroller. An automatic micro-power control unit manages the energy flow to the load. Besides, the battery is recharged from the solar energy regardless of the state of the supercapacitors. This maintains the energy stored in the supercapacitors at its maximum while the sun hides. In addition an analysis of the current requirements in the two power paths, as much in charge as in discharge, take us to maximize the efficiency within each power path, by choosing the most efficient DC-DC converters for the required currents.

3. Design

Our inexhaustible power source supplies a regulated voltage of 3.3 V to a wireless sensor node with the low power RF transceiver CC2420, which is IEEE 802.15.4 compliant. These kind of wireless devices use to spend most of the time sleeping or within some low power consumption mode in order to save energy, and duty cycles among 1 % and less than 10 % (see Figure 2) are typical in field sensing applications (Roundy et al., 2003; Polastre et al.,

2004). Therefore the design is focused for efficiently managing really low currents (around 6 μA) at sleeping mode, and responding quickly to the relatively large currents (around 22 mA) requested by the load in some active mode (transmitting, receiving or synchronizing). The active time (when the consumption is 22 mA) is fixed arbitrarily to 100 ms and the percentage is referred to this time. The rest of the time (with a load current of 6 μA) corresponds to the sleeping time. The straight lines correspond to the average current. These values of current are only approximated and they try to hardly model the power consumption of a wireless node in a network. Nevertheless these values are useful to choose the most efficient DC-DC converter for the required currents.

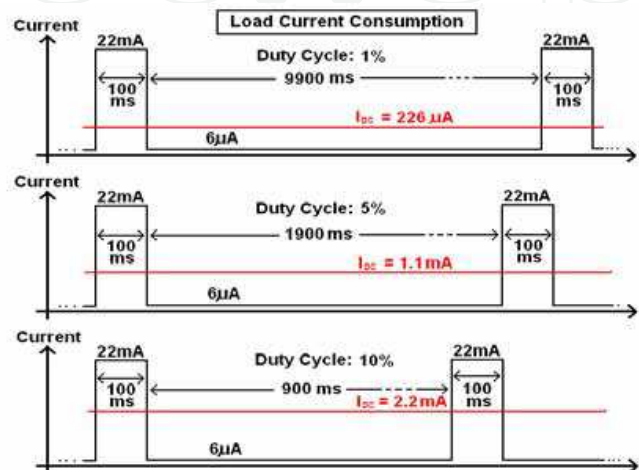

Fig. 2. Load currents tested at different duty cycles to emulate the power consumption of Wireless Sensor Node.

Thus, having in mind the amount of current requested by the storage elements and the load, and also evaluating the step-up and step-down converters in the current market, we propose and evaluate the new system architecture showed in Figure 1. There we differentiate two energy paths with different constraints; "Main", and "Backup". The currents in each path have different levels, so we take their value into account and maximize the efficiency of the "Main" path, that is the most critical path.

3.1. "Main" path

This is the energy path by default because when solar energy is available, block control gives the highest-priority to it. This is the path by where we would like to supply energy to the load permanently; this is, taking energy from the sun for both replenishing the primary buffer and delivering the required current to the load without degrading the primary buffer. This way, the use of the backup system would be minimized and lifetime of the whole system expanded.

The first element in the "Main" path is the solar panel. Since our power source needs to supply a current of at least 22 mA to the load, the selected solar panel has to be able to deliver this minimum value of current directly to the load. Nevertheless, the power source needs to supply more current for charging both storage elements. The larger is the maximum current that the solar panel is able to deliver the quicker is the recharge of the storage elements. Hence, the only upper limit of current is determined by the size of the

solar panel that fits in the application. Solar panels behave like voltage-limited current sources (Würfel et al., 2005; Chuck, 2006; Panasonic, 1999) as opposite to batteries which behave like voltage sources. They have a single operating point or well-known as Maximum Power Point (MPP). Since this operating point moves along the solar panel curves depending on the incident solar radiation, the manner of extracting the maximum power could be tracking the MPP. One could think to use some advanced DC-DC converter that adjusts its duty cycle dynamically (Koutroulis et al., 2001; Lim et al., 2000). Unfortunately, at the moment there are no commercial MPP trackers for such a low power devices. Furthermore, implementing it in a microcontroller possibly would waste more power than we earn by following the MPP with such a low voltage levels. Therefore, there are only two feasible options for efficiently coupling the solar panel and the supercapacitors; directly or using a DC-DC converter. We choose to use a DC-DC converter because it steps-up the solar panel voltage even when the sky is cloudy, reaching the appropriate voltage level for charging the supercapacitors near to its maximum every day, regardless of the solar panel voltage that depends on the solar radiation intensity.

The next element in the "Main" path is the primary buffer. This is the critical element in the design. The key design for autonomous operation is that the primary buffer needs to be recharged daily without accusing a remarkable fatigue. At the same time, it requires enough capacity to hold-up the load during the night, which minimizes the use of the secondary buffer. As it is described in "Prometheus" (Jiang et al., 2005), the only current solution is using supercapacitors. One could think about using other energy storage elements for the primary buffer, because there are other commercial elements with larger capacity like batteries. But the fact is they suffer the aging issue, that is, capacity loss manifests itself in increased internal resistance caused by oxidation with the successive recharging cycles (Buchmann, 2005; MPower, 2006). For example, a Lithium battery suffers a 10% - 20% degradation in capacitance and resistance after only 300 - 500 discharge/charge cycles, this is among one and two years supposing one cycle a day. However, nowadays the supercapacitors have reached large capacities with competitive prices with respect to the current high-capacity batteries. Compared to the Lithium battery, a supercapacitor can be deep cycled at high rates for 500.000-1.000.000 cycles for the same change in characteristics (10-20% degradation), this is among 1.500 and 3.000 years supposing one cycle a day again (Burke, 2000; Cooper, 2006). Moreover, the supercapacitors have additional advantages as pulse power devices; they have high power density, high efficiency, short recharging times, and long shelf and cycle life. In contrast, the primary disadvantage of supercapacitors is their relatively low energy density compared to batteries (Stor & Bussmann, 2007). Nevertheless, they turn the best feasible solution within this kind of low power and low duty cycle applications, where the solar power has to replenish the primary buffer daily and delivering pulsating currents to the load.

By the other hand, when there is no solar energy available, the supercapacitors will start to deliver current to the load and their voltage will start to drop. Therefore a voltage regulator is required to maximize the energy extracted from the supercapacitors and deliver it to the load, which requires a constant voltage. That voltage regulator needs to be very efficient in order to maximize the use of the energy stored in the supercapacitors and therefore minimizing the use of the secondary buffer.

3.2. “Backup” path

This energy path should provide energy to the load when the “Main” path fails; this is, when there is no direct sunlight and the supercapacitors drop below the minimum operating voltage. As it has been named earlier, the “Main” path has been designed to work as much time as possible. Therefore, it is expected “Backup” path only takes part during exceptional situations, which minimizes the recharging cycles on the secondary buffer and therefore, the stress and degradation on it.

The “Backup” path is characterized by housing a large rechargeable energy storage element, this is the secondary buffer (Figure 1), that assures the power supply to the load during long time periods without sunlight. The length of such black-out periods depends essentially on weather factors and on the geographic location. Therefore the optimal autonomy for the secondary buffer remains uncertain and one need to choose the largest rechargeable battery that adapts to the cost and size of the application. Currently there are many type of batteries in the market (Ni-Cd, Ni-MH, Lithium) but it is well-known that Lithium batteries have the highest energy density, the lowest self-discharge rates, and the lowest “memory effect” (Buchmann, 2005; MPower, 2006). Furthermore they are becoming less expensive over time. Although they require a more complex charging method, we can use some dedicated charger chip because the battery charge should only be enabled under excess of solar power conditions. This means when the primary buffer has been full replenished and solar panel maintains the appropriate voltage in their terminals.

By the other hand, the capacity of the secondary buffer can be so much larger than the primary buffer one. Hence, the secondary buffer is able to supply power to the load much more time than the primary buffer even assuming a less efficient path. Therefore “Backup” path, powered from the right sized solar panel to charge it quickly, is not such critical with the component selection, in contrast with the “Main” one.

4. Implementation

We have implemented the inexhaustible power source to supply a regulated voltage of 3.3 V to a wireless sensor node. The prototype board contains a solar panel, two supercapacitors, a Lithium-Ion battery and the energy management integrated circuits that can be seen in Figure 4.

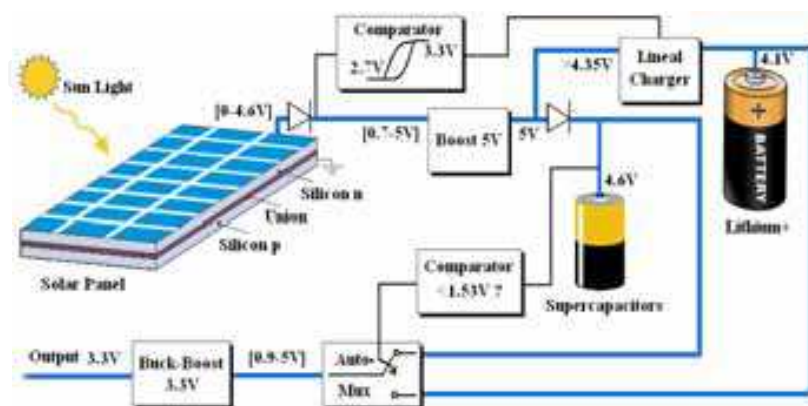

Fig. 3. Electronic schematic of the inexhaustible power source and its voltages while working.

The board also provides a 10 pin straight header that is used for measuring all the important voltages in the circuit, by means of those which an acquisition board is connected through.

4.1 Hardware

This section describes the selection of the components inside the blocks shown in Figure 1 and Figure 3, and the workbench used to test our inexhaustible power source in a house roof.

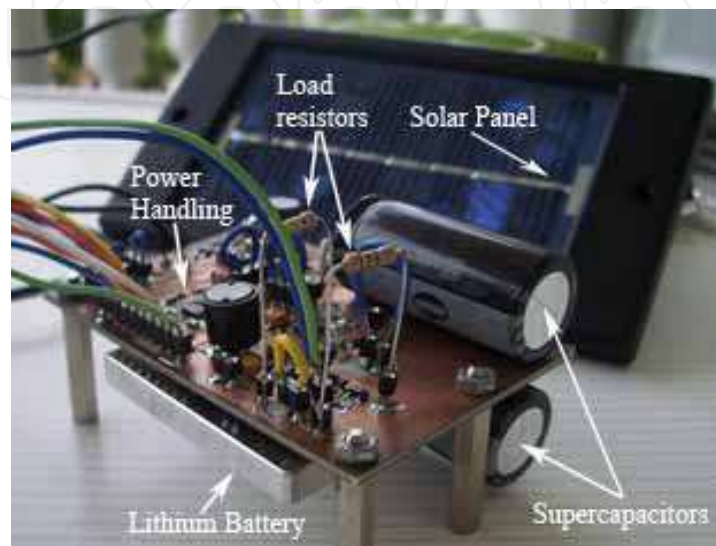

Fig. 4. Picture of the solar inexhaustible power source prototype.

1) Solar Panel

We use the MSX-005F (114 mm x 66 mm) of 0.5 W from Solarex. It was selected because its maximum power point (3.3 V) is the closest to the voltage range that manages our storage components. Moreover, it delivers 150 mA on the nominal point (at maximum solar radiation), which is much more than the maximum current that our load needs (around 22 mA). This way, the solar panel has a huge current margin to recharge the energy storage elements quickly under sunlight conditions.

2) Voltage Level Adapter

We use a step-up converter (MAX1795) between the solar panel and the supercapacitors (Figure 3). Thus, we reach the required voltage (more than 4.35V) for charging the Lithium battery and also for maximizing the charge stored in the supercapacitors. The step-up converter elevates the voltage to 5V and lets the current flows into the supercapacitors even when the sunlight is weak. This way the converter maximizes the energy extracted from the solar panel.

3) Primary Buffer (Supercapacitors)

Since each capacitor admits only 2.3V we connect two in series, that permits to charge the supercapacitors close to 4.6V and reduces the leakage current. The larger is the capacity of the supercapacitor the lower is its leakage current, but the price increases much more. We use two supercapacitors of 50F from PANASONIC due to its availability and relatively low price.

4) *Switching Power Multiplexer*

The new automatic power multiplexer from Texas (TPS2113PW) is the one in charge of selecting the power path to the load. It switches automatically between the primary and the secondary buffer depending on the voltage of the supercapacitors.

5) *Control Block*

Control block is actually embedded in other blocks. That is why it appears with dotted lines in Figure 1. It is composed by a comparator used within the voltage level adapter and a comparator within the switching power multiplexer. The first comparator, which is built in the step-up converter of the voltage level adapter, is used for enabling the charge of the Lithium-Ion battery. This takes place when the voltage measured on the solar panel is above 3.3 V (MPP), and it is disabled below 2.7 V. This comparator has a large hysteresis to prevent a false halt in the charge, due to a voltage drop when the battery starts being recharged.

The second one is a comparator built into the switching power multiplexer. It automatically switches among the inputs, assigning priority to the first one (supercapacitors). This means the second input (the battery) only is selected when the voltage of the supercapacitors drops below the minimum threshold that keeps the switching power multiplexer working on (that in this case is 1.53 V, Figure 7). This comparator also has a small hysteresis (around 60 mV) to prevent from false commutations among the inputs or energy paths.

6) *Voltage Regulator*

This block is composed by a single chip with a step-up converter and a voltage regulator. Its output is a fixed voltage at 3.3 V. We use the TPS61025 from Texas Instruments because it has a really flat efficiency graph (90 % -94 %) even at low currents (from 1 mA to 40 mA).

7) *Secondary Buffer (Battery)*

We use a 1Ah Lithium-Ion (Li+) battery due to its availability and low price.

8) *Charging control*

Since the Lithium-Ion battery is going to be used outdoors and it requires a careful and safety recharge with a limited current, we decided to use a dedicated charge control chip, the MAX1811, which limits the charge current and protects the battery.

4.2 Load (Simulation)

We include two mosfets in the prototype board. Each one has a resistor between its drain node and the output voltage (3.3 V), whose value has been calculated to obtain the load currents shown in Figure 2. This way, we digitally switch them to simulate the load current that a wireless sensor node approximately consumes, but only using two average values (22 mA and 6 μ A), which correspond to the working modes previously described (active and sleeping).

The switching of the mosfets is digitally managed by a microcontroller located in an external board that is used exclusively for the load simulation purposes, and it is powered by a portable acquisition system.

4.3 Acquisition System

We use the data acquisition board NI USB-6008 from National Instruments to sample the evolution of the most significant voltages. Since the voltages in our power source circuit do not change quickly it is enough by using this cheap acquisition module to sample eight voltage nodes every second.

The acquisition system is connected to a computer by means of a USB cable that supplies power to it. Then, a program developed using LabVIEW displays and stores the sampled data.

5. Results and discussion

We located the inexhaustible power source on a house roof for several days. Using a laptop computer connected to the portable acquisition system, we tested our inexhaustible power source sampling every second the voltage on the following nodes:

- * Solar panel terminals.
- * Output of the voltage level adapter.
- * Supercapacitors.
- * Output of the power source.
- * End battery charge signal.
- * Enable battery charge signal.
- * State multiplexer signal.
- * Battery.

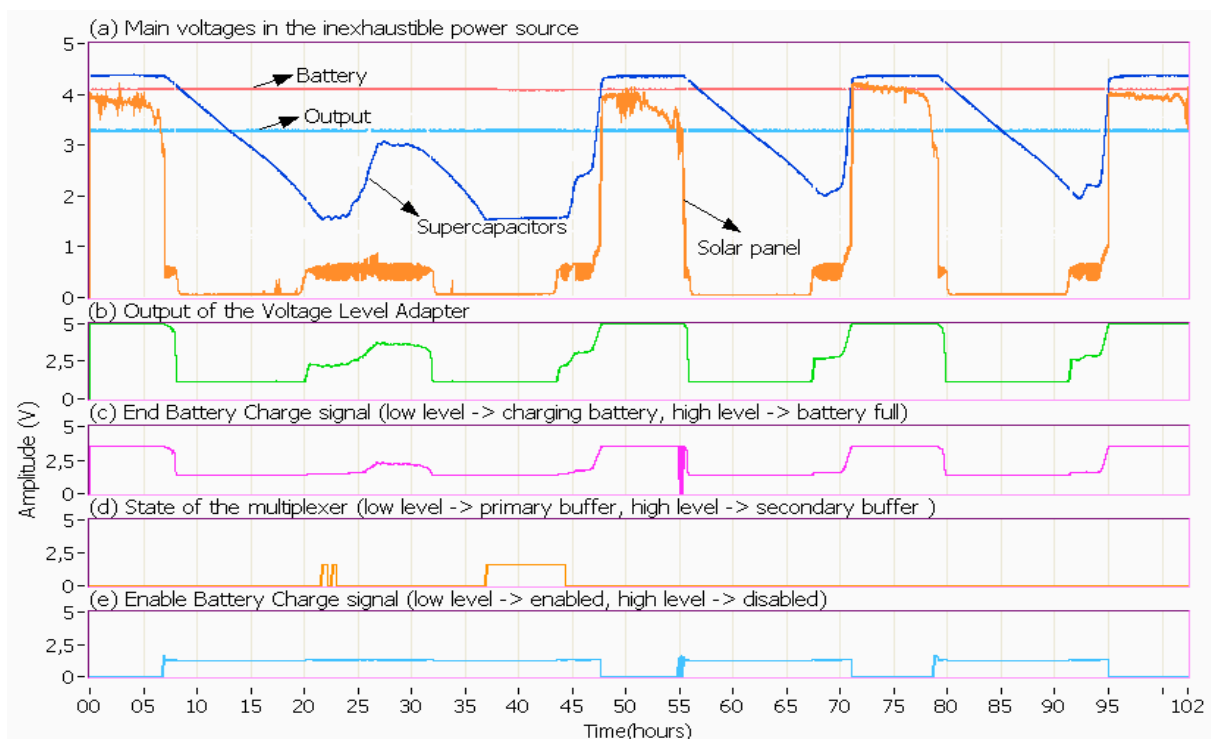

Fig. 5. Evolution of the voltages in the inexhaustible power source.

Figure 5 shows the evolution of the main voltages in the power source. In this case we let the system running autonomously during 5 days. It was supplying 3.3 V to the simulated load, which was working at 4% of duty cycle. We started the measurements on September 22 at midday 12:00 p.m. with full sunlight, the supercapacitors fully replenished at 4.35 V, and the

battery fully charged at 4.1 V (Figure 5a). The solar panel was supplying power directly to the load. After seven hours the sun started to hide and the supercapacitors assumed the main role powering the load. The first night came out (follow the solar panel voltage), and the supercapacitors did not hold-up the load current during the whole night because the second day dawned raining. Although the sunrise was at 8 o'clock (20 h after starting), the solar radiation was too weak for replenishing the supercapacitors. Therefore at 10 o'clock (22 h after starting) the supercapacitors dropped below the working threshold 1.53 V, and the system automatically switched to battery for sustaining the load current (Figure 5d). In spite of the weak sunlight on a very rainy day, the supercapacitors got to raise its voltage within the next hours thanks to the output level adaptor (Figure 5b), but clearly with a smaller slope.

This way, with the supercapacitors charged at 3 V, the system did not support the load during the whole second night, but the backup battery sustained the output voltage at 3.3 V again.

The third day came out again at 8 o'clock (44 h after starting) and this time it was a shiny day. The supercapacitors were replenished from its minimum voltage 1.53 V to its maximum voltage 4.35 V in less than three hours. Moreover since the battery was hardly discharged last day, the power source recharged the battery in a while and it is hardly appreciable in the Figure 5c. Although the Figure 5e shows when the battery is enabled to be recharged, that does not implies the battery is being recharged because this depends on whether the battery is full or not, and whether the output voltage of the voltage level adapter is higher than 4.35 V or not.

Next two sunny days, the power source kept on powering the load without using the Lithium battery. Since supercapacitors are hardly deteriorated as time goes by, the power source promises a long lifetime because the battery will be used only during adverse climate conditions, this is without almost sunlight.

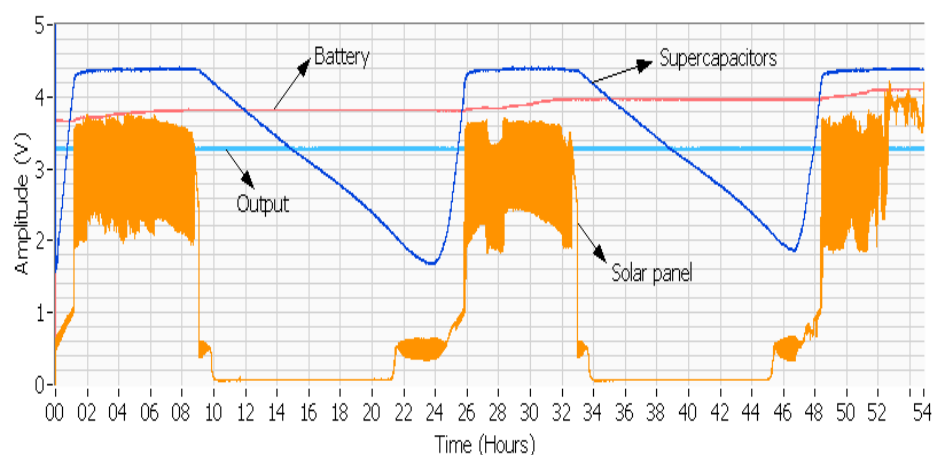

Fig. 6. This figure shows the recovery of the Lithium-Ion battery which was intentionally deeply discharged

A second measurement was carried out to evaluate the recovery time of the Lithium-Ion battery. Initially, we intentionally left the supercapacitors and the battery discharged at 1.57 V and 3.67 V respectively. Then, we exposed the solar panel to the sunlight during three days. Figure 6 shows the evolution of the voltage on the supercapacitors and on the battery, while powering the load at 4 % of duty cycle. Firstly, the energy from the solar panel was

used for fully replenishing the supercapacitors from 1.57 V to 4.35 V, which took less than 2 h. After that, although the second day was a bit cloudy, the 3.7/1Ah Lithium-Ion battery started getting energy from the sun and the battery was recharged from 3.67 V to 4.1 V in two and a half days while powering a load at 4 % of duty cycle. This demonstrates the recovery ability of this inexhaustible power source even under a deep battery discharge.

Finally we carried out some more experiments to evaluate the longevity of our power source. For that, we consider that the autonomy can be near perpetual if under normal climate conditions, this is sunny days, the solar panel and the supercapacitors hold-up the load during the whole day and the whole night. This way, depending on the geographic location, the battery is only eventually used during very rainy days.

Therefore we acquired voltage samples of the supercapacitors during many days and nights with different load currents, this is, varying the duty cycle. We centred our attention at nights, when the supercapacitors remain as the unique active energy source. Figure 7 shows the evolution of the voltage in the supercapacitors during four different nights with a load working at 1 %, 3 %, 4 % and 5 % of duty cycle. Starting with the supercapacitors fully charged and overlapping the four curves to the same hour of a day, the slope for each duty cycle can be easily compared. Moreover, Figure 7 determines that 4 % is the maximum continuous duty cycle which our power source is able to maintain in a September night without using the battery. This means 4 % is approximately the continuous duty cycle that avoids a daily discharge and recharge of the Lithium-Ion battery, expanding much more the lifetime of the entire power source.

Furthermore, using a variable duty cycle, this is adapting the load consumption to the energy available, the designed power source can work even at higher duty cycles than 4% during the day and reducing it during the night depending on the tasks of the wireless sensor node powered.

It is a hard work to predict the lifetime of our power source because it depends among other parameters on the unpredictable climate conditions, but we expect a so much longer lifetime than 3 years, which is the typical lifetime of Lithium-Ion batteries if used daily and charged and discharged deeply (Buchmann, 2005).

In addition, it is expected the battery is not deeply discharged when used in our power source, let us to assume a maximum use of 7 days, which is a long period without sunlight. Using a duty cycle of 4 % for the load of Figure 5, the average current is 886 μA , as it is noted in equation 1. With this current consumption the two supercapacitor in series are able to hold-up the system power supply during 1 day (t_{supercap}) without any recharge from the sun's energy, according to the equation 2 (Stor, 2007).

$$I_{\text{load}} = \frac{(4 \cdot 22\text{mA}) + (96 \cdot 6\mu\text{A})}{100} \approx 886\mu\text{A} \quad (1)$$

$$t_{\text{supercap}} = \frac{C \cdot (V_{\text{max}}^2 - V_{\text{min}}^2)}{I_{\text{load}} \cdot (V_{\text{max}} + V_{\text{min}})} = 1\text{day} \quad (2)$$

$$t_{\text{battery}} = \frac{1\text{Ah}}{886\mu\text{A} \cdot 24\text{hours}} \approx 47\text{days} \quad (3)$$

Where C is the nominal capacitance of the supercapacitor in Farads, I_{load} is the average current delivered to the load, V_{max} and V_{min} are the maximum and minimum threshold voltages for proper working and t is the held-up time. The expected time has been calculated with 25F, 886 μ A, 4.6V and 1.53V. The expected lifetime of the Lithium-Ion battery is 47 days ($t_{battery}$), as it has been calculated in equation 3. Thus, 7 days of discharge correspond to 15% of the total capacity, and this low discharge percentage of charge/discharge means a longer lifetime, close to what we can call near perpetual operation for such a changing technology.

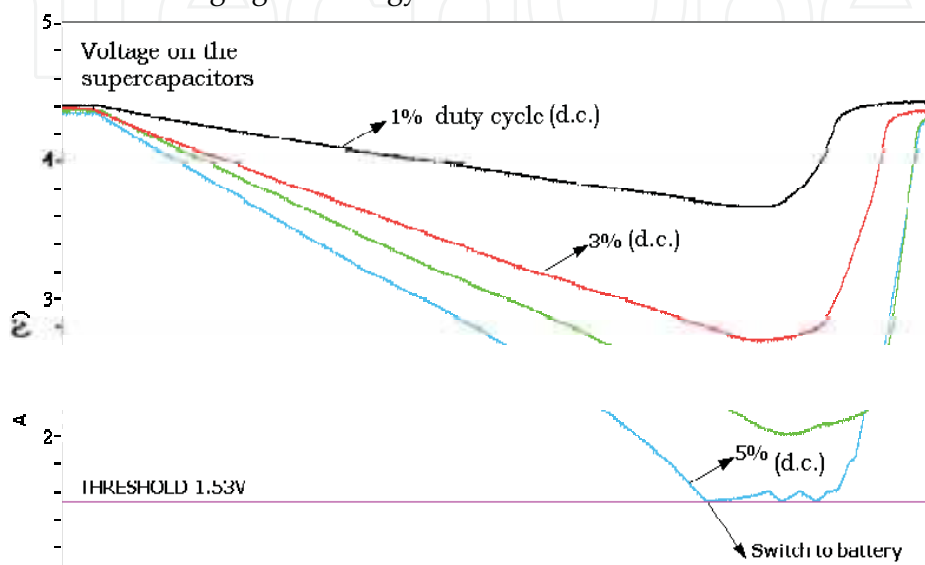

Fig. 7. This figure shows the discharge of the supercapacitors during 4 nights overlapped at different load currents. Each curve belongs to a different night.

6. Conclusion

This chapter discussed a method of design and implementation of an inexhaustible power source that without the human intervention manages and fully recharge the two energy buffers from the solar energy. After several weeks of tests the output of 3.3V has never failed and the battery has been resorted only a very rainy day. We have demonstrated autonomous operation for wireless sensor nodes with an average consumption of 886 μ A. This value corresponds to a load with a fixed 4 % of duty cycle, but we could also assure an autonomous power for even higher duty cycles in case the load adjusts its duty cycle dynamically. Since the wireless sensor node can sense the energy available in our power source, it could reduce its activity during the night and increase it during the day. Nevertheless, the duty cycle depends on the specific application and our evaluated power source could widely cover most of field sensor applications where duty cycles of 1 % or less turn out to be enough (Zhang et al., 2004; Werner-Allen et al., 2005; Noda et al., 2006).

At the end, the new system architecture, in which this power source is based, opens new frontiers to experiment with other energy scavenging sources, because an appropriate use of supercapacitors as the single primary source could eliminate the necessity of large and degradable batteries, which would mean full autonomous power.

7. References

- Alberola, J.; Pelegri, J. & Lajara, R. & Perez, Juan J. (2008). Solar Inexhaustible Power Source for Wireless Sensor Node, IEEE International Instrumentation and Measurement technology Conference, I2MTC 2008, Victoria-Canada.
- Arms, S.W.; Townsend, C.P. & Churchill, D.L. & Galbreath, J.H. & Mundell, S.W. (2005). Power Management for Energy Harvesting Wireless Sensors, International Symposium on Smart Structures & Smart Materials (SPIE), 9 March 2005, San Diego, CA.
- Buchmann, I. (2005). How to prolong lithium-based batteries (BU34), Cadex Electronics Inc., Vancouver. <http://www.batteryuniversity.com/parttwo-34.htm>
- Burke, A. (2000). Ultracapacitors: why, how, and where is the technology, *Journal of Power Sources*, Vol. 91, Issue 1, Nov. 2000, pp. 37-50.
- Chou, Pai H. & Park, C. (2005). Energy-Efficient Platform Designs for Real-World Wireless Sensing Applications, IEEE International Conference on Computer Aided Design, (ICCAD), San Jose, CA, 2005.
- Chuck Wright Consulting, LLC, (2006). The Solar Sprint PV Panel, website. <http://www.chuck-wright.com/SolarSprintPV/SolarSprintPV.html>
- Cooper Industries, (2006), Aerogel Supercapacitors - b series datasheet. <http://www.cooperet.com/products/products.cfm?page=supercapacitors>
- Dreher, R. (2004). Remote Observation Station, *Circuit Cellar: The magazine for computer applications*, Issue 162 January 2004.
- Dubois-Ferrière, H.; Meier, R. & Fabre L. & Metrailler, P. (2006). TinyNode: A Comprehensive Platform for Wireless Sensor Network Applications, *IEEE International Conference on Information Processing in Sensor Networks (IPSN)*, April 19-21, 2006, Nashville, Tennessee, USA.
- Hande, A.; Polk, T. & Walker, W. & Bhatia, D. (2006). Indoor Solar Energy Harvesting for Sensor Network Router Nodes, *Journal of Microprocessors and Microsystems Special Issue on Sensor Systems*, 2006.
- Howell Jones, M. (2004). Energy Scavenging for Sensor Networks. ELG7178F Topics in Communications II Wireless Ad-Hoc Networking November, 2004. www.howelljones.ca/tech/energyscavengefull.pdf
- Hsu, J.; Friedman, J. & Raghunathan, V. & Kansal, A. & Srivastava, M. (2005). Helimote: Enabling self-sustained wireless sensor networks through solar energy harvesting, International Symposium on Low Power Electronics and Design (ISLPED), San Diego, California, August 8-10, 2005.
- Jiang, X.; Polastre, J. & Culler, D. (2005). Perpetual Environmentally Powered Sensor Networks. IEEE International Conference on Information Processing in Sensor Networks (IPSN), Los Angeles, CA, USA, April 25-27, 2005.
- Kansal, A.; Potter, D. & Srivastava, M.B. (2004). Performance Aware Tasking for Environmentally Powered Sensor Networks, ACM Joint International Conference on Measurement and Modelling of Computer Systems (SIGMETRICS), New York, USA, 2004.
- Koutroulis, E.; Kalaitzakis, K. & Voulgaris, N. C. (2001). Development of a Microcontroller-Based, Photovoltaic Maximum Power Point Tracking Control System, *IEEE Trans. Power Electronics*, vol. 16, no. 1, Jan 2001.

- Lim, Y. H. & Hamill, D.C. (2000). Simple maximum power point tracker for photovoltaic arrays. *Electronics Letters*, IEE 2000, 24 February 2000.
- Mpower Solutions for All Your Specialist Portable Power Needs, (2006). <http://www.mpoweruk.com/performance.htm>
- Noda, C.; Fernández, J. & Pérez, C. & Altshuler, E. (2006). Measuring Activity in Ant Colonies: The Wireless Perspective, International Centre for Theoretical Physics (ICTP), February 2006, Trieste, Italy.
- Panasonic, (1999). Solar Cells Technical Handbook 98/99. <http://downloads.solarbotics.com/PDF/sunceramcat.pdf>
- Park, C. & Chou, P. H. (2004). Power Utility Maximization for Multiple Supply Systems by a Load Matching Switch. *IEEE International Symposium on Low Power Electronics and Design (ISLPED)*, pp. 168-173, Newport Beach, California, USA, 2004.
- Park, C.; Liu, J. & Chou, P.H. (2005). Eco: An ultra-compact low-power wireless sensor node for real-time motion monitoring, *IEEE International Conference on Information Processing in Sensor Networks (IPSN)*, Los Angeles, CA, USA, April 25-27, 2005.
- Polastre, J.; Szewczyk, R. & Sharp, C. & Culler, D. (2004). The Mote Revolution: Low Power Wireless Sensor Network Devices, *Hot Chips 2004*, Aug 22-24, 2004.
- Rabaey J. M. (2003). Ultra-low Power Computation and Communication enables Ambient Intelligence, *Keynote Presentations, ELMO Seminar*, Helsinki, Finland, 2003. <http://bwrc.eecs.berkeley.edu>.
- Raghunathan, V.; Kansal, A. & Hsu, J. & Friedman, J. & Srivastava, M. (2005). Design Considerations for Solar Energy Harvesting Wireless Embedded Systems, *IEEE International Conference on Information Processing in Sensor Networks (IPSN)*, pp. 457-462, Los Angeles, CA, USA, April 25-27, 2005.
- Raghunathan, V.; Kansal, A. & Hsu, J. & Friedman, J. & Srivastava, M. (2005) Design Considerations for Solar Energy Harvesting Wireless Embedded Systems, *Fourth IEEE International Conference on Information Processing in Sensor Networks (IPSN)*, Special Track on Platform Tools and Design Methods for Network Embedded Sensors (SPOTS), April 2005.
- Rahimi, M.; Shah, H. & Sukhatme, G.S. & Heideman, J. & Estrin, D. (2003). Studying the Feasibility of Energy Harvesting in a Mobile Sensor Network, *Proc. IEEE International Conference on Robotics and Automation (ICRA)*, pp. 19-24, Taipei, Taiwan, May 2003.
- Roundy, S.; Otis, B. P. & Chee, Y. & Rabaey, J. M. & Wright, P. (2003). A 1.9GHz RF Transmit Beacon using Environmentally Scavenged Energy, *IEEE International Symposium on Low Power Electronics And Devices (ISLPED)*, Seoul, Korea, 2003.
- Roundy, S.; Steingart, D. & Frechette, L. & Wright, P. K. & Rabaey, J. M. (2004). Power Sources for Wireless Sensor Network, *Proc. 1st European Workshop on Wireless Sensor Networks (EWSN)*, Berlin, Germany, 2004.
- Stor, P.; Bussmann C. (2007) Application Note: Design Considerations In Selecting Aerogel Supercapacitors, <http://www.cooperbussmann.com/3/PowerStor.html>
- Werner-Allen, G.; Johnson, J. & Ruiz, M. & Lees, J. & Welsh, M. & Marcillo, O. & (2005). Monitoring Volcanic Eruptions with a Wireless Sensor Network, *Second European Workshop on Wireless Sensor Networks (EWSN)*, Istanbul, Turkey, January-February, 2005.

- Würfel, P. (2005). Chapter 1. Introduction of Physics of Solar Cells: From Principles to New Concepts, 2005 WILEY-VCH Verlag gmbh & Co. KGaA, Weinheim. ISBN: 3-527-40428-7.
- Zhang, P.; Sadler, C.M. & Lyon, S.A. & Martonosi, M. (2004). Hardware Design Experiences in ZebraNet, ACM Conference on Embedded Networked Sensor Systems (SenSys), Baltimore, Maryland, USA, November 3-5, 2004.

IntechOpen

IntechOpen

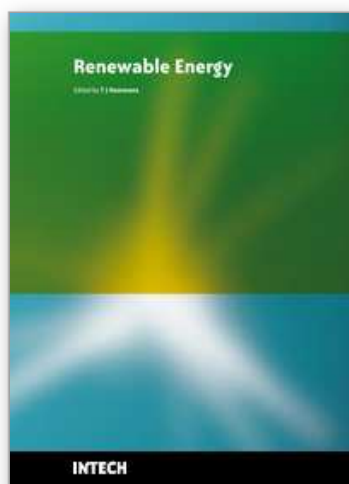

Renewable Energy

Edited by T J Hammons

ISBN 978-953-7619-52-7

Hard cover, 580 pages

Publisher InTech

Published online 01, December, 2009

Published in print edition December, 2009

Renewable Energy is energy generated from natural resources-such as sunlight, wind, rain, tides and geothermal heat-which are naturally replenished. In 2008, about 18% of global final energy consumption came from renewables, with 13% coming from traditional biomass, such as wood burning. Hydroelectricity was the next largest renewable source, providing 3% (15% of global electricity generation), followed by solar hot water/heating, which contributed with 1.3%. Modern technologies, such as geothermal energy, wind power, solar power, and ocean energy together provided some 0.8% of final energy consumption. The book provides a forum for dissemination and exchange of up-to-date scientific information on theoretical, generic and applied areas of knowledge. The topics deal with new devices and circuits for energy systems, photovoltaic and solar thermal, wind energy systems, tidal and wave energy, fuel cell systems, bio energy and geo-energy, sustainable energy resources and systems, energy storage systems, energy market management and economics, off-grid isolated energy systems, energy in transportation systems, energy resources for portable electronics, intelligent energy power transmission, distribution and inter-connectors, energy efficient utilization, environmental issues, energy harvesting, nanotechnology in energy, policy issues on renewable energy, building design, power electronics in energy conversion, new materials for energy resources, and RF and magnetic field energy devices.

How to reference

In order to correctly reference this scholarly work, feel free to copy and paste the following:

Jose Pelegri-Sebastia, Rafael Lajara Vizcaino and Jorge Alberola Lluch (2009). Solar Power Source for Autonomous Sensors, Renewable Energy, T J Hammons (Ed.), ISBN: 978-953-7619-52-7, InTech, Available from: <http://www.intechopen.com/books/renewable-energy/solar-power-source-for-autonomous-sensors>

INTECH
open science | open minds

InTech Europe

University Campus STeP Ri
Slavka Krautzeka 83/A
51000 Rijeka, Croatia
Phone: +385 (51) 770 447
Fax: +385 (51) 686 166
www.intechopen.com

InTech China

Unit 405, Office Block, Hotel Equatorial Shanghai
No.65, Yan An Road (West), Shanghai, 200040, China
中国上海市延安西路65号上海国际贵都大饭店办公楼405单元
Phone: +86-21-62489820
Fax: +86-21-62489821

© 2009 The Author(s). Licensee IntechOpen. This chapter is distributed under the terms of the [Creative Commons Attribution-NonCommercial-ShareAlike-3.0 License](https://creativecommons.org/licenses/by-nc-sa/3.0/), which permits use, distribution and reproduction for non-commercial purposes, provided the original is properly cited and derivative works building on this content are distributed under the same license.

IntechOpen

IntechOpen