

# We are IntechOpen, the world's leading publisher of Open Access books Built by scientists, for scientists

4,800

Open access books available

122,000

International authors and editors

135M

Downloads

Our authors are among the

154

Countries delivered to

TOP 1%

most cited scientists

12.2%

Contributors from top 500 universities



WEB OF SCIENCE™

Selection of our books indexed in the Book Citation Index  
in Web of Science™ Core Collection (BKCI)

Interested in publishing with us?  
Contact [book.department@intechopen.com](mailto:book.department@intechopen.com)

Numbers displayed above are based on latest data collected.

For more information visit [www.intechopen.com](http://www.intechopen.com)



# The Deployment of Intelligent Transport Services by using DVB-Based Mobile Video Technologies

Vandenbergh, Leroux, De Turck, Moerman and Demeester  
*Ghent University  
Belgium*

## 1. Introduction

ITS systems combine (wired and wireless) communication systems, innovative applications, integrated electronics and numerous other technologies in a single platform. This platform enables a large number of applications with an important social relevance, both on the level of the environment, mobility and traffic safety. ITS systems make it possible to warn drivers in time to avoid collisions (e.g. when approaching the tail of a traffic jam or when a ghost driver is detected) and to inform them about hazardous road conditions. Navigation systems can take detailed real-time traffic info into account when calculating their routes. In case of an accident, the emergency services can be automatically informed about the nature and the exact location of the accident, saving very valuable time in the first golden hour. In case of traffic distortions, traffic can be immediately diverted. These are just a few of the many applications that are made possible because of ITS systems, but it is very obvious that these systems can make a significant positive contribution to traffic safety. In literature it is estimated that the decrease of accidents with injuries or fatalities will be between 20% and 50% (Bayle et al., 2007).

Attracted by the high potential of ITS systems, the academic world, the standardization bodies and the industry are all very actively involved in research and development of ITS solutions. The pillars of these systems are the communication facilities connecting the vehicles, the roadside infrastructure and the centralized safety and comfort services. Several wireless technologies can be considered when designing ITS architectures, and they can be divided into three categories: Dedicated Short Range Communication (DSRC) of which IEEE 802.11p WAVE, ISO CALM-M5 and the ISO CALM-IR standard are typical examples, wireless Wide Area Networks (WAN) such as GPRS, WiMAX and UMTS and finally digital broadcast technologies like RDS, DAB and the DVB specifications (DVB-T, DVB-S, DVB-H, etc.).

Since so many suitable technologies exist or are in development today, it is very hard to decide on which technologies future ITS architectures should be based. This problem is the starting point of several major ITS research projects, where much attention is given to solutions based on DSRC and wireless WAN networks. In the CVIS project, the implementation focuses on CALM-M5, CALM-IR, GPRS and UMTS technology (Eriksen et al., 2006). The Car2Car Communication Consortium aims to create and establish an open European industry standard for car2car communication systems based on the WAVE

Source: Digital Video, Book edited by: Floriano De Rango,  
ISBN 978-953-7619-70-1, pp. 500, February 2010, INTECH, Croatia, downloaded from SCIYO.COM

standard (Baldessari et al., 2007). The COOPERS project evaluates the GPRS, CALM IR and DAB communication media (Frötscher, 2008). Although broadcast technologies are not neglected by the research community, it is harder to find examples focused on this category. As already mentioned, the COOPERS project has some attention for DAB, and in Korea a trial implementation of a TPEG based traffic information service system was deployed on their T-DMB network (Cho et al., 2006).

In this book chapter, we focus on the usage of DVB-H and DVB-SH for ITS systems. This approach is driven by the lower cost for the end user compared to wireless WAN solutions, by the lack of scalability issues and by the high provided bandwidth. Section 2 introduces the mobile broadcast technologies that are used in our architecture, and explains what the advantages are of using them in ITS systems. Section 3 describes how heterogeneous communication in mobile environments can be realized by means of the ISO TC204/WG16 CALM standard. This standard enables the seamless combination of DVB-H/SH with other wireless communication technologies such as IEEE 802.11p WAVE or an UMTS internet connection. In section 4 the functional description of our architecture is elaborated, the service architecture is described and a more in depth explanation of the implementation details is given. In section 5, the conclusions are drawn and section 6 finishes with the acknowledgment of the enablers of our research.

## 2. Mobile broadcast technologies

In this section we will elaborate on the broadcast specifications on which our architecture is based upon. We will first shortly introduce each specification and then explain why these technologies are used in our architecture and what the advantage is of using them instead of other communication standards.

### 2.1 Broadcasting to Handhelds ( DVB-H)

DVB-H (Digital Video Broadcasting - Handheld) is a technical specification (ETSI, 2004) for bringing broadcast services to handheld receivers. It adapts the successful DVB-T (Terrestrial) system for digital terrestrial television to the specific requirements of handheld, battery-powered receivers. The conceptual structure of a DVB-H receiver is depicted in Fig. 1. It includes a DVB-H demodulator and a DVB-H terminal. The DVB-H demodulator includes a DVB-T demodulator, a time-slicing module and a MPE-FEC module.

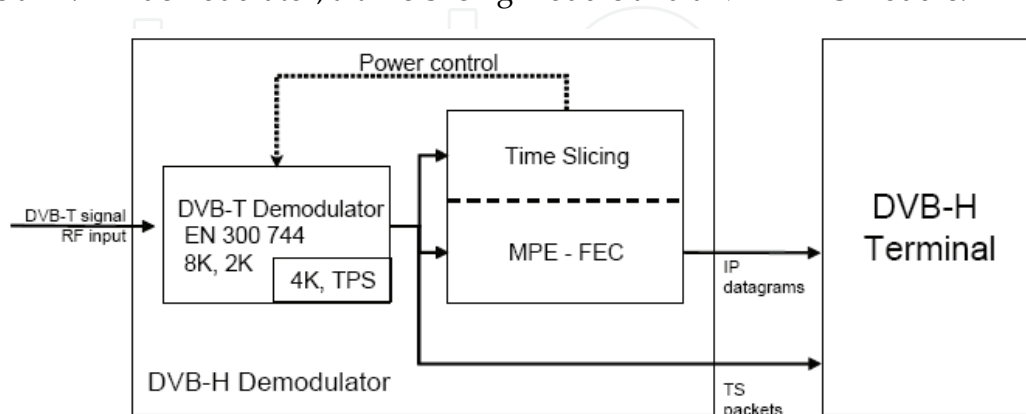

Fig. 1. Conceptual structure of a DVB-H receiver.

The DVB-T demodulator recovers the MPEG-2 Transport Stream packets from the received DVB-T RF signal. It offers three transmission modes 8K, 4K and 2K with the corresponding

Transmitter Parameter Signaling (TPS). Note that the 4K mode, the in-depth interleavers and the DVB-H signaling have been defined while elaborating the DVB-H standard. It aims to offer an additional trade-off between single frequency network (SFN) cell size and mobile reception performance, providing an additional degree of flexibility for network planning.

The time-slicing module, provided by DVB-H aims to save receiver power consumption while enabling to perform smooth and seamless frequency handover. Power savings of up to 90% are accomplished as DVB-H services are transmitted in bursts (using a high instantaneous bit rate), allowing the receiver to be switched off in inactive periods. The same inactive receiver can be used to monitor neighboring cells for seamless handovers. Time-slicing is mandatory for DVB-H.

The objective of Multi-Protocol Encapsulation - Forward Error Correction (MPE-FEC) is to improve the mobile channel tolerance to impulse interference and Doppler effect. This is accomplished through the introduction of an additional level of error correction at the MPE layer. By adding parity information calculated from the datagrams and sending this parity data in separate MPE-FEC sections, error-free datagrams can be output (after MPE-FEC decoding) even under bad reception conditions.

**DVB-H** is designed to be used as a bearer in conjunction with the set of DVB-IPDC (see Section 2.3) systems layer specifications. DVB-H has broad support across the industry. Currently, more than fifty DVB-H technical and commercial trials have taken place all over the world and further commercial launches are expected. In March 2008 the European Commission endorsed DVB-H as the recommended standard for mobile TV in Europe, instructing EU member states to encourage its implementation.

## 2.2 Satellite Services to Handhelds (DVB-SH)

DVB-H is primarily targeted for use in the UHF bands (but may also be used in the VHF- and L-band), currently occupied in most countries by analogue and digital terrestrial television services. DVB-SH (ETSI, 2007a; ETSI, 2008) seeks to exploit opportunities in the higher frequency S-band, where there is less congestion than in UHF. The key feature of DVB-SH is the fact that it is a hybrid satellite/terrestrial system that will allow the use of a satellite to achieve coverage of large regions or even a whole country. This is shown in Fig. 2. TR(a) are broadcast infrastructure transmitters which complement reception in areas where satellite reception is difficult, especially in urban areas; they may be collocated with mobile cell site or standalone. Local content insertion at that level is possible, relying on adequate radio frequency planning and/or waveform optimizations.

TR(b) are personal gap-fillers of limited coverage providing local on-frequency re-transmission and/or frequency conversion; typical application is indoor enhancement under satellite coverage; no local content insertion is possible.

TR(c) are mobile broadcast infrastructure transmitters creating a "moving complementary infrastructure". Depending on waveform configuration and radio frequency planning, local content insertion may be possible.

DVB-SH's major enhancements when compared to its sister specification DVB-H are:

- The availability of more alternative coding rates.
- The inclusion of support for 1.7 MHz bandwidth.
- FEC using Turbo coding.
- Improved time interleaving.

As mentioned above, DVB-H systems have already been widely deployed, mostly on a trial basis so far. DVB-SH will be a complement to DVB-H and could potentially be used as such

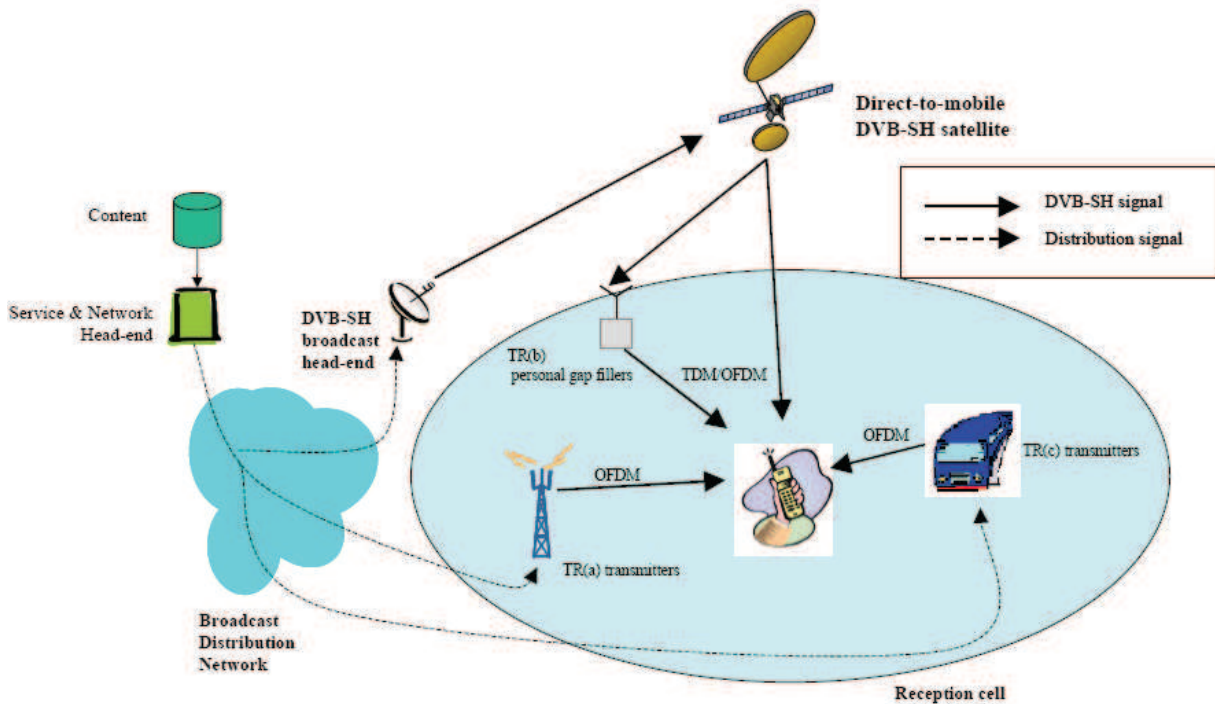

Fig. 2. Overall DVB-SH system architecture.

in a number of ways. Nationwide coverage could be achieved with the satellite footprint. Terminals that are in development will be dual mode, receiving DVB-SH in S-Band and DVB-H at UHF, and the over-lapping use of the DVB-IPDC specifications ensures that the two systems will be complementary.

### 2.3 Internet Protocol Datacast (DVB-IPDC)

Many commercial mobile TV networks are likely to be hybrid networks combining a uni-directional broadcast network, typically involving a wide transmission area and high data throughput, with a bi-directional mobile telecommunications network, involving much smaller transmission areas (cells). The set of DVB specifications for IP Datacasting (DVB-IPDC) (ETSI, 2007b) are the glue that bind these two networks together so that they can cooperate effectively in offering a seamless service to the consumer.

DVB-IPDC is originally designed for use with the DVB-H physical layer, but can ultimately be used as a higher layer for all DVB mobile TV systems. Currently, work is ongoing to make the necessary additions and adaptations to the DVB-IPDC specifications to allow interfacing with the DVB-SH standard. This work already resulted in the recent document "DVB Document A112-2r1: IP Datacast over DVB-SH". DVB-IPDC consists of a number of individual specifications that, taken together, form the overall system. The way the different elements fit together is defined in a reference architecture of the IPDC system whilst a further specification sets out the various use cases that are allowed for within the system.

The protocolstack of an IP Datacast over DVB-H system is shown in Fig. 3. The integration of an IP layer in the broadcaststack is one of the key concepts of an IPDC system. These IP datagrams are encapsulated inside the MPEG Transport Stream (TS) using MPE and MPE-FEC to improve mobile performance. For the delivery of streaming media, IP Datacast specifies the use of the Real-time Transport Protocol (RTP) and file delivery is performed by using File Delivery over unidirectional Transport (FLUTE) (IETF, 2004). FLUTE is a protocol



for unidirectional delivery of files over the Internet. In Section 3.3 we elaborate on the DVB-IPDC specifications as we point out how ITS services are incorporated into our architecture.

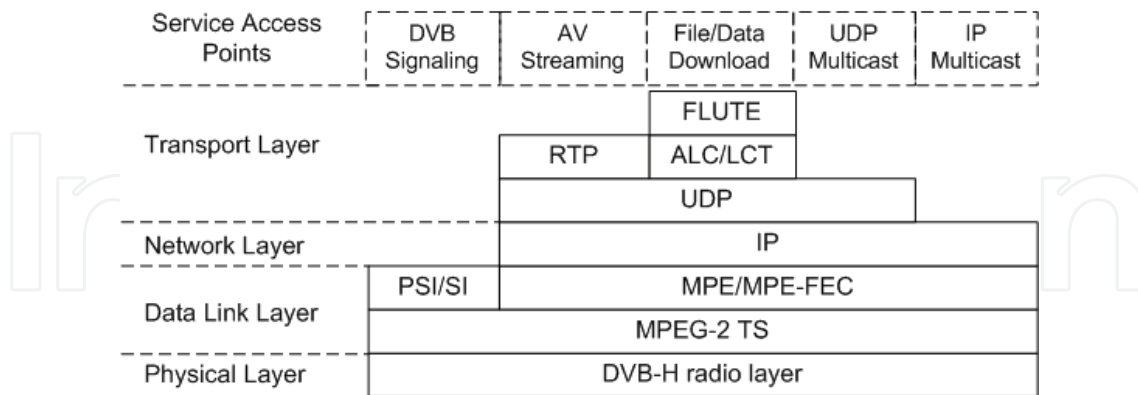

Fig. 3. The DVB-IPDC protocol stack.

### 2.4 Advantages of using DVB-H/SH as bearer technology

The goal of this section is to point out why DVB-H/SH technology is a very well suited candidate for the implementation of ITS systems. First, the advantages of using a digital broadcast technology are described. Second, we compare DVB-H and DVB-SH with other (mobile) broadcast technologies.

As already mentioned in the introduction, several wireless technologies can be considered when designing ITS architectures. There are roughly three categories of wireless systems that may be used: DSRC, wireless WAN and digital broadcast technologies. DSRC systems typically have a limited range of a few up to a few hundred meters. They were originally designed for direct link communications such as toll collect, but newer technologies support multi-hop communications. Examples are the IEEE 802.11p WAVE standard, or the ISO CALM-M5 standard. Wireless WAN technologies have a much larger range, and typically provide internet connectivity to mobile devices. Examples are GPRS, UMTS and WiMAX. Digital broadcast technologies can also cover large areas, but they do not offer two-way communications, only broadcast services. Examples technologies are RDS, DAB and the on DVB based technologies such as DVB-T or DVB-S.

When selecting a technology for the implementation of ITS systems, it is important to know that using broadcast technologies instead of wireless WAN solutions has some important advantages:

**Scalability** - Using a broadcast medium offers independence of the number of users that are connected to the system and thus the number of users that is able to receive ITS services. Antennas of non-broadcast systems could become overloaded when e.g. there is a traffic jam and all the car terminals would retrieve the same traffic info from the same antenna that covers the traffic jam's region.

**Low cost - high user adoption** - Recent large-scale motorist surveys have revealed that although users find ITS systems very useful, they are not very willing to pay for these services (RACC Automobile Club, 2007). This means that the cost of wireless WAN solutions could be a major stumbling block in the adoption of ITS systems by motorists. As broadcast media may provide free-to-air services, the cost to end users is kept much lower. When ITS systems use e.g. UMTS as the bearer technology then even if the service itself is free, the user (or the terminal manufacturer) still has to pay for the UMTS data connection.

Another cost-lowering property of broadcast technology is the fact that it enables travellers to enjoy ITS services abroad without having to pay expensive roaming fees.

Within the group of broadcast technologies, the usage of DVB-H and DVB-SH provides some additional advantages compared with its competitors:

**Mobility** – As DVB-H and DVB-SH are specifically developed for the delivery of data to handheld terminals, they provide a lot of error correction mechanisms for terminals that are moving at high speed. This is a major advantage over e.g. DVB-T.

**High Bandwidth** – As DVB-H and DVB-SH are initially developed for the delivery of mobile TV services, they provide a much bigger bandwidth (8 to 15 mbit per second for DVB-H) in comparison to other standards such as DAB (120 kbit per second) and RDS (1.1 kbit per second) (Chevul et al., 2005).

**Industry adoption** – As already mentioned in the previous sections, DVB-H has become the European standard for mobile television thus giving DVB-H a lead to other mobile television technologies such as T-DMB. This advantage is of course dependant on the region where the ITS service will be deployed but note that the deployment of DVB-H (and in the near future DVB-SH) is definitely not restricted to only Europe.

**User adoption** – When using DVB-H and DVB-SH technology for ITS services, user can also receive DVB-H/SH digital television broadcasts on their on-board equipment. This extra comfort service could be an important feature to attract new users, and could prove to be the catalyst that accelerates the adoption of on-board ITS equipment. The consumer interest in on-board television can already be observed today: portable DVD-players have become common consumer products, and some of the newest personal navigation devices can already receive DVB television broadcasts (e.g. Garmin nüvi).

**Return channel integration** – As DVB-IPDC is specifically designed for the convergence of DVB-H and DVB-SH with a bidirectional channel such as UMTS (through the integration of an IP layer), mobile terminals can still make use of a return channel. Since only the client uplink data will be transported over this return channel, the data cost will be much lower than when only using a unicast channel. This combination of technologies heavily relieves the bidirectional channel, having a positive influence on the scalability issues of wireless WAN solutions.

All the above makes it obvious that an ITS system based on IP Datacast over DVB-H/SH theoretically has many advantages, but as with all new technologies the question remains if the technology will be able to live up to the expectations in practice. Based on our experience within the IBBT MADUF project (MADUF, 2008), which was a trial DVB-H rollout in the city of Ghent, we are convinced that this will indeed be the case. In this trial we implemented our own middleware framework for the delivery of interactive services through DVB-H (Leroux et al., 2007). Measurements were also done concerning the performance of DVB-H for in-car usage (Plets et al., 2007). This trial made clear that DVB-IPDC is very suitable for the delivery of non-video data and that DVB-H has a good performance, even when using in a car at high speed.

### 3. Heterogeneous communication in mobile environments

In this section, we elaborate on the ISO TC204/WG16 CALM standard (Williams, 2004). This standard is the ISO approved framework for heterogeneous packet-switched communication in mobile environments, and supports user transparent continuous communications across various interfaces and communication media. It is, together with the DVB-H/SH broadcast technology, one of the key components of the ITS architecture presented in this book chapter.

The CALM architecture is depicted in Fig. 4. The two main elements are the CALM router, which provides the seamless connectivity, and the CALM host which runs the ITS applications with varying communication requirements. On both the CALM router and the host, different subcomponents can be distinguished:

- **CALM communication interface:** the CALM Communication Interface (CI) consists of a communication module and the necessary service access point for interfacing with the CALM networking layer (C-SAP)
- **CALM networking layer:** the CALM networking layer routes packets to the appropriate functional unit or program addressed. It also isolates the upper OSI layers from the different technologies that are making the connections. CALM supports multiple optional and complementary network protocols running independent of each other. Example protocols are standard IPv6 routing; CALM FAST, which is a non-IP protocol required for user applications with severe timing constraints and low-latency requirements (e.g. time-critical safety related applications); and geographic-aware routing, with or without map information. The CALM networking layer also provides a service access point for interaction with the CALM User Services / Applications (the T-SAP)
- **CALM management:** The CALM communications and station management comprises global functionality, and functionality grouped into three groups: Interface Management Entity (IME), Network Management Entity (NME) and CALM Management Entity (CME). Disregard of this grouping, the CALM management is one entity, and there are no observable or testable interfaces between IME, NME and CME. The role of the IME is to directly control the communication interfaces, and to allow access to a communication interface for the purpose of receiving and transmitting management data packets. The role of the NME is to directly control the network and transport layer protocols. The CME provides the decision-making process to the CALM mechanism. The CME collects the specification of the communication parameters enabled by each of the desired communications mechanisms and the requirements from each of the applications from the initialization process. It monitors the availability of lower level communications mechanisms and issues. Based on this information and on policies a decision on how to route data packets is made.
- **CALM service layer:** The CALM service layer shall provide an application programmer interface (API) to user applications, and it shall provide an A-SAP to the CME. Using the API, applications can easily define how their data should be exchanged with other CALM nodes (local broadcast, n-hop broadcast, directional communication, unicast to known address, ...), the level of importance of the data (for QoS classification), the delay constraints, etc.
- **CALM applications:** three kinds of applications can run on the CALM host: CALM FAST applications, CALM IP-based applications, and non-CALM aware applications. The first category has the ability to control the interaction with the CALM environment. Such applications can respond to CALM management entity requests for registration information or are able to request registration upon initialization. They get real-time access to pre-selected parameters of specific CALM communication interfaces in line with applicable regulations, and to the CALM networking layer in order to control the real-time behaviour of the communication link. This control functionality includes e.g. power settings, channel settings, beam pointing. These applications typically use the CALM FAST or Geo-routing networking protocols. CALM IP-based applications are



similar to CALM FAST applications, but they typically have less stringent timing constraints, and are more session oriented. Therefore they generally use the IPv6 networking protocol. Non-CALM aware applications operate with the assumption of the programmer that a normal UDP or TCP connection is being established for communication. Such applications operate without the ability to control any interaction with the CALM environment. The CALM management entity must hide all CALM environment peculiarities from these applications.

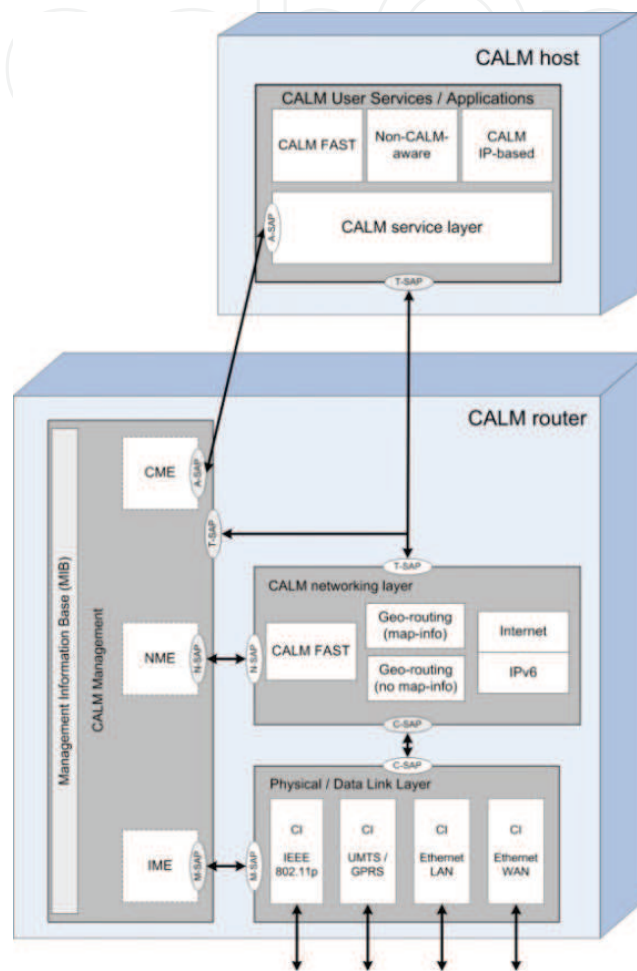

Fig. 4. The CALM architecture

## 4. Architecture

In this section, we present our ITS architecture based on IP Datacast over DVB-H/SH. First, the functional description of the architecture and its global communication aspects are described. Then the service architecture is detailed, and finally some implementation details of the architecture will be given.

### 4.1 Functional description

The core idea of the communication architecture (Fig. 5) is to use DVB technology to broadcast data to the vehicles. When DVB-H coverage is already available, this infrastructure can be reused, minimizing necessary investments. If this is not the case, rural areas can be covered by a single DVB-SH satellite, and DVB-SH repeater antennas can be

installed in urban areas to guarantee coverage. Communication between vehicles is provided by the IEEE 802.11p WAVE technology. Since the combination of DVB and WAVE technologies provides both communication from the central infrastructure to the vehicles, and between vehicles, most ITS applications are supported by this base architecture (collision avoidance, hazardous road warnings, traffic situation-aware navigation, etc.). If the user requires interactive applications (notification of emergency services, sending info to the traffic control centre, etc.) the base architecture can be expanded with a return channel, e.g. by using existing UMTS infrastructure.

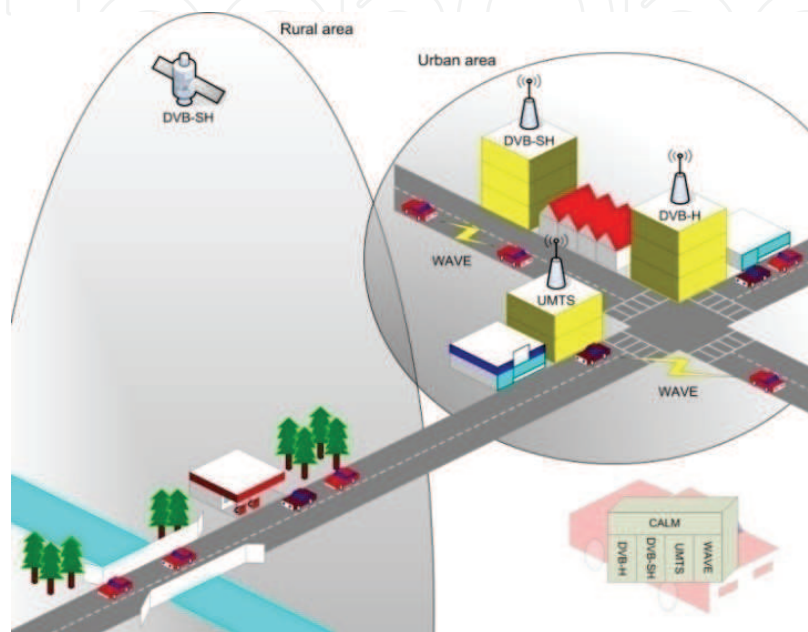

Fig. 5. Communication architecture

In this communication architecture, it is necessary to equip every vehicle with at least a WAVE module and a DVB-H or DVB-SH receiver. Optionally, an UMTS module can also be installed. To coordinate the collaboration of these different wireless interfaces, we rely on the ISO TC204/WG16 CALM standard (Williams, 2004) described in section 3. This standard is the ISO approved framework for heterogeneous packet-switched communication in mobile environments, and supports user transparent continuous communications across various interfaces and communication media. It already supports WAVE and UMTS technology, and due to its modular design, it can easily be expanded to support DVB-S/H media. The CALM standard is, together with the WAVE standard, one of the most important upcoming communication standards within the ITS domain. Since both technologies are incorporated in the architecture, it is compliant with current and future ITS trends and activities.

Since the proposed communication architecture is based on the usage of DVB-H/SH, it inherits the advantages of this technology (see section 2.4): the cost to end users is kept low, scalability issues do not arise, and users can enjoy extra comfort services such as mobile digital television.

#### 4.2 Service architecture

The service architecture of the proposed ITS solution is depicted in Fig. 7. An important concept within this service architecture is the use of the Transport Protocol Expert Group

(TPEG) standards. TPEG is a bearer and language independent Traffic and Travel Information (TTI) service protocol which has a unidirectional and byte oriented asynchronous framing structure (Cho et al., 2006). It is defined in two standards: TPEG binary, originally developed for digital radio, and tpegML, developed for internet bearers and message generation using XML. Integrating them into our service architecture makes the architecture compliant with current and future ITS trends and activities.

```

<?xml version="1.0" encoding="ISO-8859-1" ?>
<!DOCTYPE tpeg_document (View Source for full doctype...)>
- <tpeg_document generation_time="2009-07-13T13:58:09+0">
- <tpeg_message>
  <originator country="UK" originator_name="BBC Travel News" />
  <summary xml:lang="en">M25 Surrey - Two lanes closed and queueing traffic anticlockwise due to overturned lorry between
  J8, Reigate and J7 M23</summary>
- <road_traffic_message message_id="3147219" message_generation_time="2009-07-13T13:37:52+0" version_number="7"
  start_time="2009-07-13T13:26:03+0" stop_time="2009-07-13T14:37:37+0" severity_factor="very severe">
- <obstructions number_of="1">
- <vehicles number_of="1">
  <vehicle_problem vehicle_problem="overturned" />
  <vehicle_info vehicle_type="lorry" />
</vehicles>
</obstructions>
- <network_conditions>
  <position position="driving lane 1" />
  <restriction restriction="restriction" />
</network_conditions>
- <network_performance>
  <performance network_performance="queueing traffic" />
</network_performance>
- <location_container language="English">
- <location_coordinates location_type="route">
  <WGS84 latitude="51.258436" longitude="-0.198008" />
  <location_descriptor descriptor_type="road number" descriptor="M25;" />
  <location_descriptor descriptor_type="town name" descriptor="Surrey" />
  <location_descriptor descriptor_type="intersection name" descriptor="Reigate" />
  <location_descriptor descriptor_type="junction name" descriptor="M25; 8" />
  <location_descriptor descriptor_type="Junction with" descriptor="A217;" />
  <WGS84 latitude="51.263682" longitude="-0.127723" />
  <location_descriptor descriptor_type="road number" descriptor="M25;" />
  <location_descriptor descriptor_type="town name" descriptor="Surrey" />

```

Fig. 6. TpegML example

In our architecture, the tpegML variant will be used for broadcasting traffic information. The advantage of this XML based flavour is that tpegML can be decoded by end-users with any XML enabled browser, tpegML messages are human understandable and machine readable, and tpegML messages are usable with and without navigation systems (European Broadcasting Union, 2009). An example tpegML message is shown in Fig. 6 (BBC, 2009).

As shown in Fig. 7, the service architecture contains the several entities involved, and how they relate to each other. Together, they provide all the mechanisms needed by ITS systems, from content generation to end user applications. The Traffic Control Centre is responsible for generating road traffic information, and forwarding it to the TPEG service provider. The information is produced using several sources such as cameras and counter loops in the road. It can include various kind of information, e.g. real time average travel time on road segments, incident reports and speed limit alterations.

The Public Transport Services are the different public transport operators (e.g. bus, rail or air operator). They possess information regarding their operations, and are responsible for sending this information (such as schedules, delays, etc.) to the TPEG service provider.

The Touristic Info Services can be any entity involved in touristic activities, and they can send metadata information that links to their web servers to the TPEG service provider. The real data on the web servers is available on demand through the return channel.

Optionally, very popular information may also be sent to the Broadcast Network Provider for transmission on a dedicated broadcast channel.

The TPEG service provider is responsible for gathering all kinds of ITS relevant data from different sources and generating TPEG message from this content. It is also responsible for

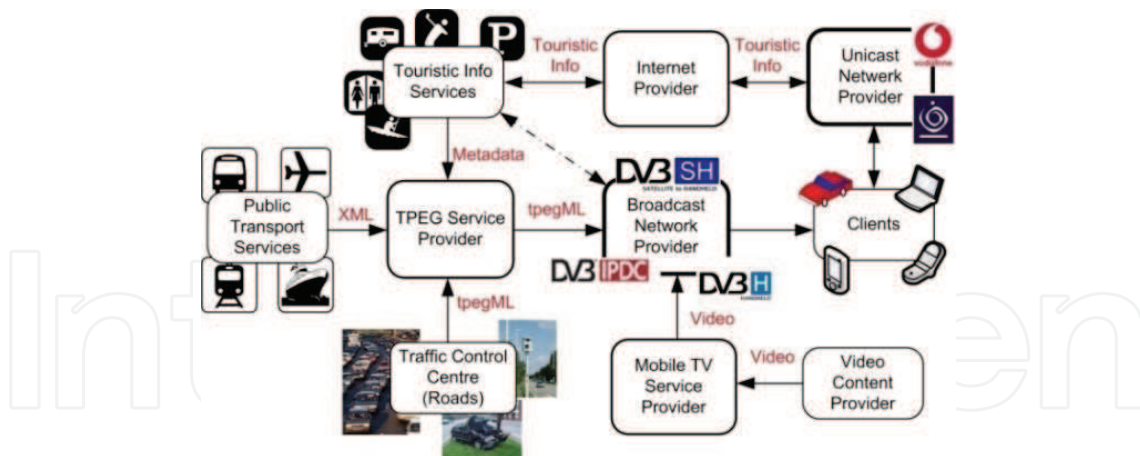

Fig. 7. Service architecture

providing these messages to the end user. Therefore, it will deliver the generated tpegML messages to the broadcast network provider. From the end users perspective, the TPEG service provider is the contact point for ITS information.

The Video Content Providers produces digital television programs and delivers them to the Mobile TV Service Provider. The Mobile TV Service Provider collects content from different Video Content Providers, and is responsible for providing this content to the clients. From the end user point of view, the Mobile TV Service Provider is the contact point for mobile digital television.

The Broadcast Network Provider is responsible for the DVB-H or DVB-SH network. It broadcasts digital television and ITS information to the end devices. It receives this content from the TPEG service provider and the Mobile TV Service Provider.

The clients are all the devices that can receive DVB-S/H broadcasts. The most obvious example is the in-vehicle infotainment system, but this can also be a PDA, a personal navigation device or a mobile phone.

The Unicast Network Provider is responsible for the wireless network that provides the (optional) two-way communication necessary for interactive applications. The Internet Provider is responsible for the internet access for clients connected to the unicast network. In most cases, the Internet Provider and the Unicast Network Provider will be the same company, both from a logical and service provider point of view they are two separate entities.

### 4.3 Implementation details

This subsection provides a more in depth explanation of how the required services can be provided over DVB-H/SH. Attention is given to the question how TPEG services can be integrated into the IPDC headend, and how the tpegML files can be delivered through FLUTE.

#### 4.3.1 Integrating TPEG services in the IPDC headend

Fig. 8 details how the ITS services are integrated into a typical DVB-IPDC headend. In our setup, the Video Content Provider streams its multimedia data over SDI (Serial Digital Interface) to the encoders. These H.264 encoders also encapsulate all the data into RTP packets. Following the protocol stack as defined by DVB-IPDC, these RTP-streams are sent over UDP and then multicast into the Multicast IP Network. At the TPEG Service Provider, a file server sends all the tpegML data to the Flute Server of the headend.

Both the encoders (through Session Description Protocol (SDP) (IETF, 1998) files) and the TPEG Service Provider (not standardized) sent metadata to the ESG server in order to make



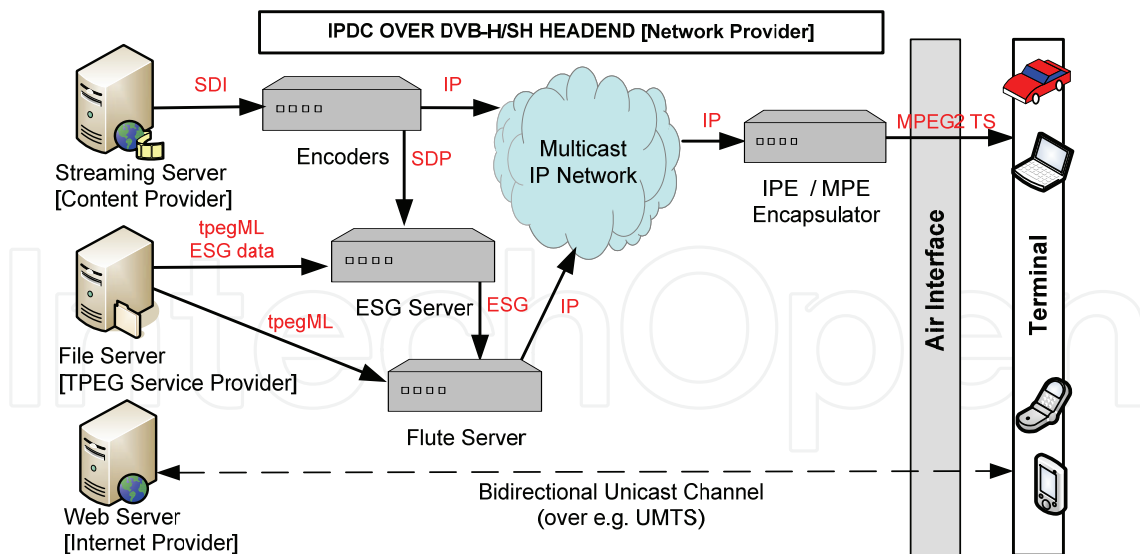

Fig. 8. Coupling of the TPEG Service Provider with the IPDC over DVB-H/SH headend

sure that the TPEG middleware and the decoders are able to find and correctly interpret all the broadcasted data. All the ESG data is then sent to the Flute server which will multicast all the data into the Multicast IP Network.

The IPE/MPE Encapsulator encapsulates all the multcasted IP packets into an MPEG2 TS (transport stream). This MPEG2 TS is then sent to the satellite or antennas, where the stream is finally modulated and sent over the air to the user's terminal. As a return channel, a bidirectional unicast channel such as e.g. UMTS may be used to acquire more information (such as local touristic information) through the Internet Provider. Note that for single frequency networks (SFN) an additional component, a so-called SFN adapter, should be placed after the IP/MPE encapsulators.

#### 4.3.2 Delivery of tpegML through FLUTE

DVB-IPDC not only defines protocols for the delivery of audio and video streams, but it also specifies how binary files should be incorporated into the MPEG data streams and sent to the end users. This IPDC file delivery mechanism is based on the FLUTE protocol (IETF, 2004). FLUTE (File delivery over Unidirectional Transport) is a fully-specified protocol to transport files (any kind of discrete binary object), and uses special purpose objects - the File Delivery Table (FDT) Instances - to provide a running index of files and their essential reception parameters in-band of a FLUTE session. FLUTE is built on top of the Asynchronous Layered Coding (ALC) protocol instantiation (IETF, 2002) which provides reliable asynchronous delivery of content to an unlimited number of concurrent receivers from a single sender. FLUTE is carried over UDP/IP, and is independent of the IP version and the underlying link layers used.

There are 5 types of file delivery sessions that are specified on the basis of FLUTE. We will only detail the most advanced session type, more specifically the Dynamic file delivery carousel as this is the required method in our architecture for the delivery of ITS related data to all the users. A dynamic file delivery carousel is a possibly time-unbounded file delivery session in which a changing set of possibly changed, added or deleted files is delivered. The use of a carousel mechanism (of which teletext is a typical example) is necessary as in a broadcast scenario you don't know exactly when a user tunes in. As a carousel mechanism



continuously repeats or updates the traffic info, users who just started their car will still be able to receive all relevant traffic info, even if they missed the initial message.

The time that a random user has to wait for its traffic info will be dependent on the size of the carousel. As we want to support an unlimited number of TPEG services in our architecture, encompassing all these services into the same data carousel would invoke a round trip time of the data carousel that is much too high. Secondly, the use of one big carousel would ensue that the antenna has to be turned on for longer periods which in turn partly undoes one of the main advantages of DVB-H/SH, namely the reduced power consumption. Therefore we use one main FLUTE data carousel which continuously repeats all road related traffic info. After each such road related traffic block, exactly one other object is placed. This second object will be one of the public transport services or the touristic metadata. As already explained in section III.B, the touristic metadata only informs the user's terminal where to find specific information, related to the current location of the terminal.

Our FLUTE data carousel is illustrated in Fig. 9. Object 1 always contains the road-related data. As shown in Fig. 9, object 1 is continuously repeated while changes in this object (object 1') and the fact that the second object is continuously alternating are indicated by the File Delivery Table (object 0).

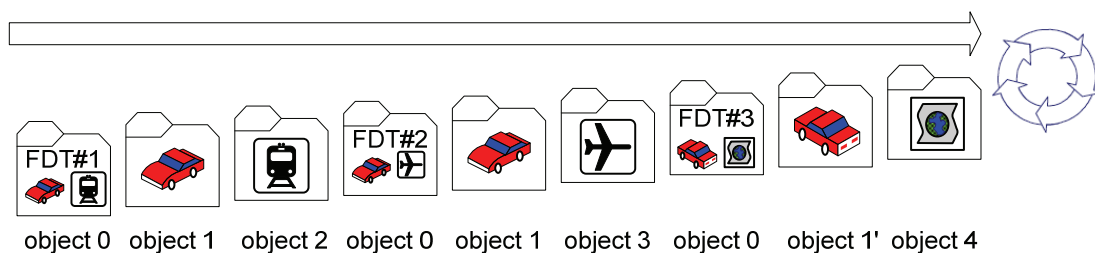

Fig. 9. Delivering ITS services via a dynamic FLUTE carousel

Note that DVB-IPDC only specifies that one FLUTE channel should be supported but that the use of several concurrent FLUTE channels may be supported by the terminals. For terminals that do not support multiple channels, it should be possible for them to receive enough data from the first channel named base FLUTE channel in order to declare the channel as complete. In our architecture the base FLUTE channel contains all the information that comes from the Traffic Control Centre and the changes in Bus, Rail and Air operator services. As such, all DVB-H terminals shall automatically be able to receive all the traffic related info. If the manufacturer finds it relevant to also support other services than the manufacturer may still incorporate the support of multiple FLUTE sessions into its devices. Terminals that do not support multiple channels shall ignore all but the base FLUTE channel.

## 5. Conclusion

In this paper we presented an ITS architecture that was based on the usage of the mobile broadcast technologies DVB-H and DVB-SH. It was explained why these technologies are very well suited for the delivery of ITS services and what the advantages are of using these technologies. The proposed architecture is complimentary with the available set of DVB-IPDC specifications and details were provided of how exactly ITS services should be integrated into a DVB-IPDC system.

## 6. Acknowledgment

The authors would like to thank the Flemish Interdisciplinary institute for Broadband technology (IBBT) for defining the MADUF and NextGenITS projects.

## 7. References

- Baldessari, R.; Bödekker, B.; Brakemeier, A. et al (2007). *CAR 2 CAR Communication Consortium Manifesto*, deliverable of C2C-CC project
- Bayly, M.; Fildes, B.; Regan, M. & Young K. (2007). Review of crash effectiveness of Intelligent Transport Systems, *Deliverable D4.1.1-D6.2*, TRACE project
- BBC (2009). *BBC Travel News – TPEG*, accessed online at <http://www.bbc.co.uk/travelnews/xml/> on July 13<sup>th</sup> 2009
- Chevil; Karlsson; Isaksson et al (2005). Measurements of Application-Perceived Throughput in DAB, GPRS, UMTS and WLAN Environments, *Proceedings of RVK'05*, Linköping, Sweden
- Cho, S.; Geon, K.; Jeong, Y.; Ah, n C.; Lee, S.I. & Lee, H. (2006). Real Time Traffic Information Service Using Terrestrial Digital Multimedia Broadcasting System. *IEEE transactions on broadcasting*, vol. 52, no 4, 2006
- Eriksen, A.; Olsen, E.; Evensen K. et al (2006). Reference Architecture, *Deliverable D.CVIS.3.1*, CVIS project
- European Broadcasting Union (2009). *TPEG- What is it all about?*, accessed online at <http://tech.ebu.ch/docs/other/TPEG-what-is-it.pdf> on June 25<sup>th</sup> 2009
- ETSI (2004). *EN 302304 v1.1.1: Digital Video Broadcasting (DVB), Transmission System for Handheld Terminals (DVB-H)*
- ETSI (2007a). *TS 102 585 V1.1.1: System Specifications for Satellite services to Handheld devices (SH) below 3 GHz - TS 102 585*
- ETSI(2007b). *TS 102 468 V1.1.1: Digital Video Broadcasting (DVB); IP Datacast over DVB-H: Set of Specifications for Phase 1*
- ETSI (2008). *EN 302 583 V1.1.0: Framing Structure, channel coding and modulation for Satellite Services to Handheld devices (SH) below 3 GHz*
- DVB Document A112-2r1. Digital Video Broadcasting (DVB); IP Datacast: Electronic Service Guide (ESG) Implementation Guidelines Part 2: IP Datacast over DVB-SH.
- Frötscher, A. (2008). *Co-operative Systems for Intelligent Road Safety*, presentation of COOPERS project, available on [http://www.coopers-op.eu/uploads/media/COOPERS\\_Presentation\\_TRA\\_Ljubljana\\_2008.pdf](http://www.coopers-op.eu/uploads/media/COOPERS_Presentation_TRA_Ljubljana_2008.pdf)
- IETF (1998). *RFC 2327: SDP, Session Description Protocol*
- IETF (2002). *RFC 3450: Asynchronous Layered Coding (ALC) Protocol Instantiation*
- IETF RFC 3926: *FLUTE- File Delivery over Unidirectional Transport*, 2004.
- Leroux, P.; Verstraete, V.; De Turck, F. & Demeester, P. (2007). Synchronized Interactive Services for Mobile Devices over IPDC/DVB-H and UMTS, *Proceedings of IEEE Broadband Convergence Networks*, Munchen
- MADUF, <https://projects.ibbt.be/maduf>, 2008.
- Plets, D.; Joseph, W.; Martens, L.; Deventer, E. & Gauderis, H. (2007). Evaluation and validation of the performance of a DVB-H network, *2007 IEEE International Symposium on Broadband Multimedia Systems and Broadcasting*, Orlando, Florida, USA
- RACC Automobile Club (2007). Stakeholder utility, data privacy and usability analysis and recommendations for operational guarantees and system safeguards: Europe, *Deliverable D.DEPN.4.1*, CVIS project
- Williams, C.C. B. (2004). *The CALM handbook*, available on <http://www.tc204wg16.de/Public/The%20CALM%20Handbookv2-060215.pdf>



## **Digital Video**

Edited by Floriano De Rango

ISBN 978-953-7619-70-1

Hard cover, 500 pages

**Publisher** InTech

**Published online** 01, February, 2010

**Published in print edition** February, 2010

This book tries to address different aspects and issues related to video and multimedia distribution over the heterogeneous environment considering broadband satellite networks and general wireless systems where wireless communications and conditions can pose serious problems to the efficient and reliable delivery of content. Specific chapters of the book relate to different research topics covering the architectural aspects of the most famous DVB standard (DVB-T, DVB-S/S2, DVB-H etc.), the protocol aspects and the transmission techniques making use of MIMO, hierarchical modulation and lossy compression. In addition, research issues related to the application layer and to the content semantic, organization and research on the web have also been addressed in order to give a complete view of the problems. The network technologies used in the book are mainly broadband wireless and satellite networks. The book can be read by intermediate students, researchers, engineers or people with some knowledge or specialization in network topics.

### **How to reference**

In order to correctly reference this scholarly work, feel free to copy and paste the following:

Vandenberghe, Leroux, De Turck, Moerman and Demeester (2010). The Deployment of Intelligent Transport Services by using DVB-Based Mobile Video Technologies, Digital Video, Floriano De Rango (Ed.), ISBN: 978-953-7619-70-1, InTech, Available from: <http://www.intechopen.com/books/digital-video/the-deployment-of-intelligent-transport-services-by-using-dvb-based-mobile-video-technologies>

**INTECH**  
open science | open minds

#### **InTech Europe**

University Campus STeP Ri  
Slavka Krautzeka 83/A  
51000 Rijeka, Croatia  
Phone: +385 (51) 770 447  
Fax: +385 (51) 686 166  
[www.intechopen.com](http://www.intechopen.com)

#### **InTech China**

Unit 405, Office Block, Hotel Equatorial Shanghai  
No.65, Yan An Road (West), Shanghai, 200040, China  
中国上海市延安西路65号上海国际贵都大饭店办公楼405单元  
Phone: +86-21-62489820  
Fax: +86-21-62489821

© 2010 The Author(s). Licensee IntechOpen. This chapter is distributed under the terms of the [Creative Commons Attribution-NonCommercial-ShareAlike-3.0 License](#), which permits use, distribution and reproduction for non-commercial purposes, provided the original is properly cited and derivative works building on this content are distributed under the same license.

IntechOpen

IntechOpen