

We are IntechOpen, the world's leading publisher of Open Access books Built by scientists, for scientists

4,800

Open access books available

122,000

International authors and editors

135M

Downloads

Our authors are among the

154

Countries delivered to

TOP 1%

most cited scientists

12.2%

Contributors from top 500 universities



WEB OF SCIENCE™

Selection of our books indexed in the Book Citation Index
in Web of Science™ Core Collection (BKCI)

Interested in publishing with us?
Contact book.department@intechopen.com

Numbers displayed above are based on latest data collected.

For more information visit www.intechopen.com



RFID in Metal Environments: An Overview on Low (LF) and Ultra-Low (ULF) Frequency Systems

D. Ciudad, P. Cobos Arribas, P. Sanchez and C. Aroca
*ISOM, ETSI Telecomunicación, Universidad Politécnica de Madrid (UPM),
Spain*

1. Introduction

Depending on their frequency, radio waves can be absorbed by water and biological tissues (Bottomley & Andrew, 1978). They can also be shielded by metals due to the eddy currents. These effects constitute a huge problem for the implementation of radio frequency identification (RFID) systems in real environments.

RFID systems can be classified into three different groups depending on the physics involved: i) inductive coupling; ii) back-scattering; and iii) electrical coupling. Another classification can be done attending to the electromagnetic band used: i) LF (125-134.5 kHz); ii) HF (13.56 MHz); iii) UHF (~900 MHz); and iv) ISM (2.4 GHz). The last three systems (HF, UHF and ISM) require an environment without metals or water to work properly. On the other hand, LF systems are less affected by metals on the surroundings and can penetrate some materials like water, but they cannot work properly through metals due to the shielding or detuning of the electromagnetic signal. These problems could be avoided by reducing the working frequency. However, both LF and HF systems are based on the inductive coupling between tag and reader and this coupling become rapidly inefficient with the frequency reduction.

Some different solutions have been proposed to solve these problems. In this chapter we explain the basics of the inductive coupling method and the detuning and shielding effects due to metals. Additionally, a new system that is able to work at ultra-low frequencies ULF (1-100 kHz) and through a metallic shielding is proposed. Finally we compare the properties of the LF and the new ULF systems.

2. Inductive coupling based systems and metal environments

2.1 Basics on the inductive coupling method

Inductive coupling between two wires appears when the change in the current flow through one wire induces a voltage across the ends of the other wire. See Figure 1.

The reader (or transceiver) powers the tag (or transponder) through an AC electromagnetic field. The reader can also modulate this electromagnetic field to send information to the tag. Once the tag is powered, it can change the energy it takes from the electromagnetic field. These changes of energy give rise to some other changes in the powering of the reader. It

Source: Radio Frequency Identification Fundamentals and Applications, Design Methods and Solutions, Book edited by: Cristina Turcu, ISBN 978-953-7619-72-5, pp. 324, February 2010, INTECH, Croatia, downloaded from SCIYO.COM

allows the tag to send information. An accurate model of LF systems is given in (EM Microelectronic, 2002). Inductive systems can be modelled as the circuit showed in Figure 2 (EM Microelectronic, 2002).

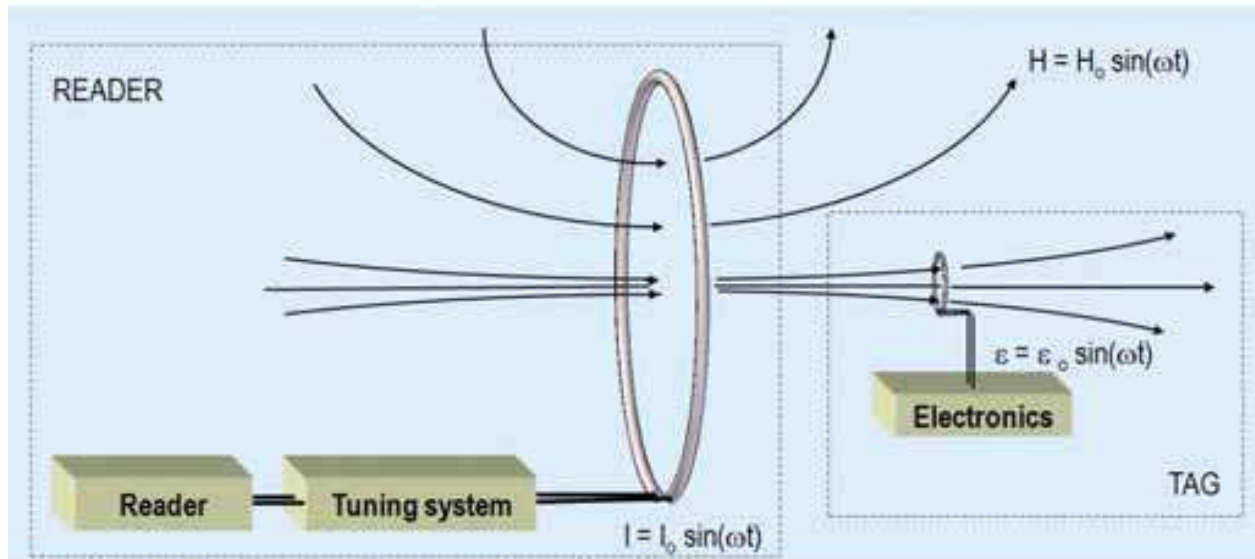

Fig. 1. Schematics of the inductive coupling.

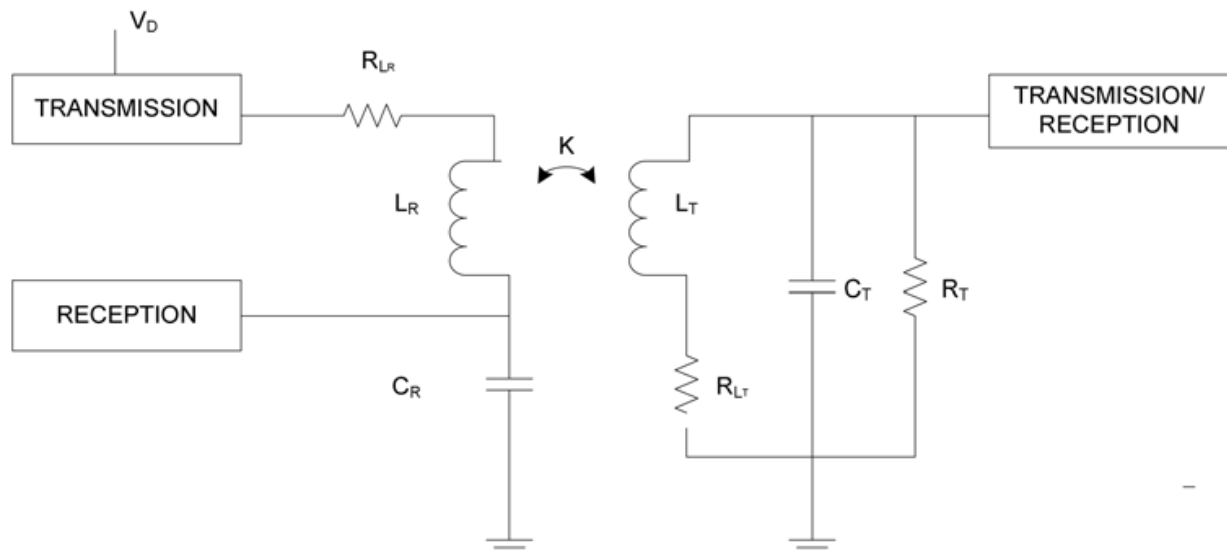

Fig. 2. Model of the LF systems. The circuit in the left is the reader. This one in the right is the tag.

This circuit allows the accurate calculation of the coupling factor k between reader and tag. It can be done by using the theory of transformers. See (EM Microelectronic, 2002).

Here we will not calculate the k factor. We will only analyse the resonance frequency. Both reader and tag must be tuned at the same resonance frequency to maximize k . The resonance frequency f_0 is given for both circuits by:

$$(Reader) \quad f_0 = \frac{1}{2\pi\sqrt{L_R C_R}} \tag{1}$$

$$\text{(Tag)} \quad f_0 = \frac{1}{2\pi\sqrt{L_T C_T}} \quad (2)$$

As introduced in Figure 2, L_R and C_R are the inductance and the capacitance of the reader, and L_T and C_T these of the tag.

2.2 Influence of metals in radio frequency systems: distortion of the magnetic field, detuning, and shielding

The different effects produced by metals on RFID systems comes from the presence of eddy currents. These effects are: i) distortion of the electromagnetic field; ii) detuning; and iii) shielding. As a result, the readable area is reduced. See Figure 3.

The inductive coupling method is based on the resonance of the antenna-tag circuit. The metal produces a drift of the working frequency. This is the so called detuning effect. A proper design of the system can allow RFID systems to work with metals on the surroundings avoiding this effect. Some different techniques and methods have been proposed. They are based on introducing dielectric gaps in between the metal and the tag, or in the use of magnetic materials like ferrite in the tag. See for example (Dixon et al., 2007), (Dixon et al., 2008) and (Bovelli et al., 2006).

Shielding happens when working through metals. Sometimes it can be avoided by using a set of different antennas. However, if the tag is enclosed in metals it can only work in some particular geometries that include dielectric gaps (Finkenzeller, 2003).

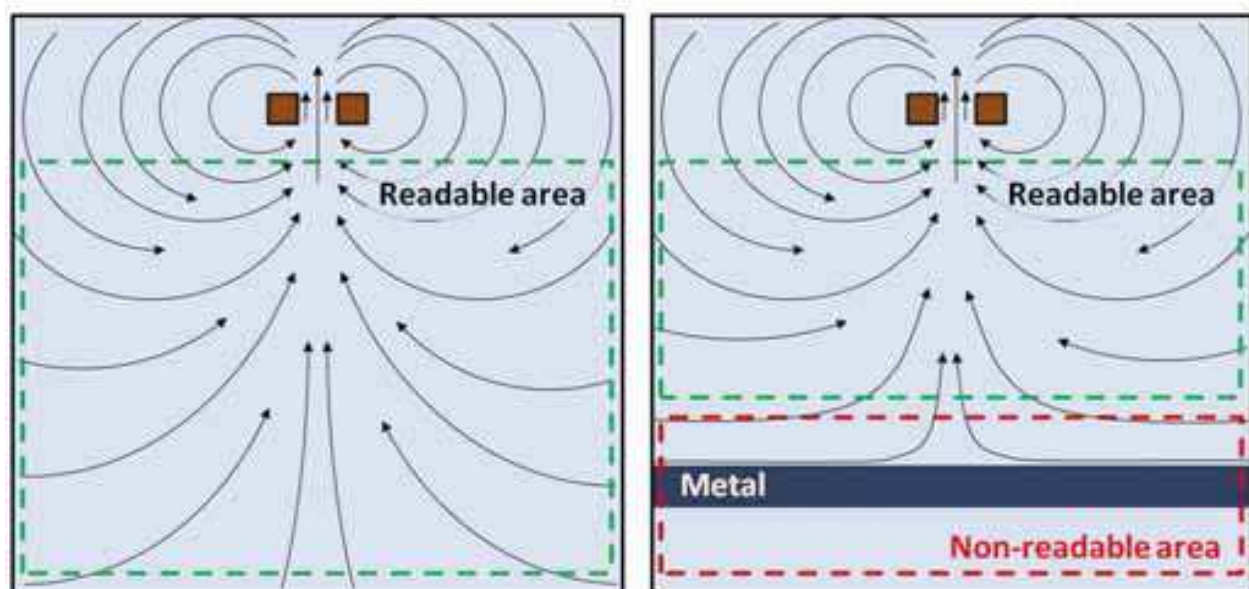

Fig. 3. Effect of a metal layer on an alternating magnetic field. On the left: the magnetic field produced by a wire in an environment without metals. On the right: the lines of the magnetic field are distorted by a metallic layer.

2.2.1 Distortions of the magnetic field

From Maxwell's equations and the appropriate boundary conditions, it is obtained that only normal electric fields to the surface and tangential components of the magnetic field are

allowed in the surface of a perfect conductor. A metal is not a perfect conductor but it still produces a deformation of the magnetic field close to its surface. For mathematical details see (Balanis, 1997).

In addition, eddy currents appear in any conductive material in the presence of an AC electromagnetic field. These currents create a magnetic field perpendicular to the surface of the conductor.

As a result of these effects, a common planar RFID tag cannot work when it is in close contact to the surface of a metal. An appropriate design of the RFID system must be done to allow the tag to work close to metallic objects.

In (Dobkin & Weigand, 2005) it is shown a study on the read range of HF RFID tags as a function of the length of the gap between tag and a metal or water. This is not so critical in LF systems, but it still can cause some problems.

2.2.2 Detuning

Detuning happens due to eddy currents which produce a magnetic field perpendicular to the metal layer. This field opposes the original magnetic field applied. When metals are in between the reader and the tag or in the surroundings, they can be modelled as an additional parallel inductance, L_M , on the circuit of the tag (Hoeft & Hofstra, 1988).

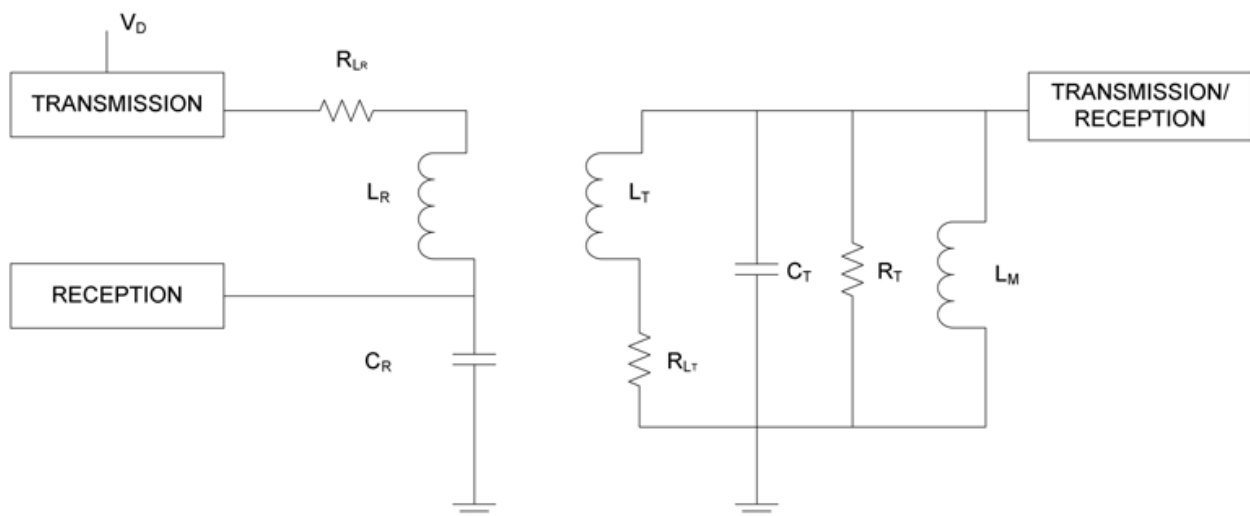

Fig. 4. Model of the LF system with metals on the surroundings of the tag.

The new inductance produces a change of this circuit resonant frequency from f_0 to f_1 :

$$\text{(Tag + metal)} \quad f_1 = \frac{1}{2\pi\sqrt{L_{Teff}C_T}} \quad (3)$$

L_{Teff} is the effective inductance:

$$L_{Teff} = \frac{L_T L_M}{L_T + L_M} \quad (4)$$

The effect is usually a reduction of the total inductance (Bowler & Huang 2005). It increases the working resonance frequency f_{res} . Metals can also introduce a parasitic capacitance.

These parasitic impedances cause the detuning of the system since the resonance frequency of the reader and that of the tag are different. It hinders the tag from being properly powered. If the metallic material is placed close to the reader, the impedance of the reader also changes. It can be used to measure the conductivity of materials through eddy currents (Bowler & Huang 2005). In RFID this effect also produces the detuning of the system.

2.2.3 Shielding and power loss

Shielding is also due to eddy currents. They allow the metal to absorb RF energy reducing the effectiveness of a RFID system. If an electromagnetic wave propagates through a metal a distance t_s , its amplitude B_0 is exponentially reduced according to the Skin's formula:

$$B'_0 = B_0 e^{-\frac{t_s}{\delta}} \quad (5)$$

B'_0 is the amplitude of the magnetic field after having covered the distance t_s through the metal. The parameter δ is the penetration depth. This is the distance in which the amplitude of the magnetic field is reduced a factor e . For a good conductor, δ is given by:

$$\delta = \sqrt{\frac{2}{\mu_s \sigma \omega}} \quad (6)$$

μ_s is the permeability of the metal, σ its conductivity and ω the angular frequency of the electromagnetic field. Figure 5 shows the penetration depth δ for different metals.

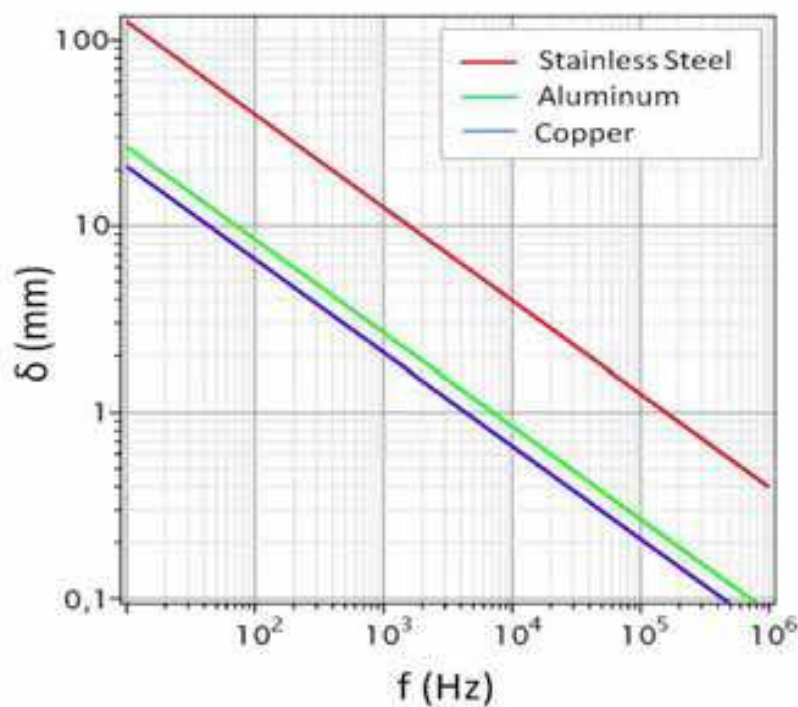

Fig. 5. Penetration depth versus frequency for different materials. $\mu \sim \mu_0$. The conductivity is 1.51 MS/m for stainless steel, 35.40 MS/m for aluminium and 58.00 MS/m for copper. Data from (Lide, 2009) and (Bowler & Huang, 2005)

Even if the detuning problems are avoided, the tag of a LF RFID system will only receive a fraction of the total energy without shielding. This is due to the reduction of the intensity of the magnetic field. Eddy currents and their related effects are explained in detail in (Ida & Bastos, 1997). Being H_0 the amplitude of the applied magnetic field when reaching the surface of the metal, the average power loss per unit volume in the metal due to eddy currents is:

$$p = \frac{1}{24} \sigma \omega^2 t_s^2 \mu_s^2 H_0^2 \quad (7)$$

Inductive coupling-based systems can work through metals only with thicknesses below the penetration depth approximately. Thicker layers completely shield the tag. For example, attending to Figure 5 it can be roughly concluded that LF RFID systems cannot work through any aluminium layer thicker than 0.25 mm.

3. RFID through metals: ultra-low frequency ULF system

In this section we explain the new ULF RFID system. It is able to work in metallic noncleaned surroundings and even through metals. This is achieved by operating at ultra-low frequencies (1- 100 kHz). In the ULF range, inductive coupling cannot be used due to: i) the loss of the efficiency - in the inductive coupling it decreases squarely with the frequency-; ii) detuning problems; and iii) the high inductance and capacitance values needed to produce the resonance of the circuit. Instead, the capability of work at such low frequencies in a non-resonant system is achieved by measuring the change of the magnetization of a magnetic core integrated in the tag.

3.1 System description

The main idea is to measure changes on the magnetization of a magnetic material included in the tag. The ultra low-frequency RFID system is formed by three different elements:

1. An antenna to produce an ultra low frequency magnetic field
2. A tag with a soft magnetic core and a winding around it.
3. A reader to detect any change on the magnetization of the tag.

The antenna produces an AC magnetic field that magnetizes the tag. The antenna must provide an area to place the reader without being magnetically saturated. This objective can be achieved by using different geometrical coil arrangements.

The tag has a low resistance winding around the magnetic core. When this winding is in open-circuit configuration, the magnetic field produced by the antenna magnetizes the magnetic material in the tag. At the same time in the winding it is induced an electromotive force (e.m.f.) able to feed a microcontroller. On the other hand, when the winding is in shortcircuit configuration, a current is induced in it. This current avoids the magnetization of the magnetic core. The micro-controller located in the tag can send information by opening and short-circuiting the winding. It produces some changes in the magnetization of the core that are easy to detect with a magnetic sensor.

The reader is a fluxgate in which a double demodulation in-phase technique is performed (Aroca et al., 1995). In the inductive systems, both the reception coil and tag must have large cross section areas and high turn number to work at low frequencies. An effective way to reduce the size of the antenna without losing effective cross section is to use soft-magnetic cores. This is one of the basics of the fluxgate magnetic sensors. Due to its magnetic core, the

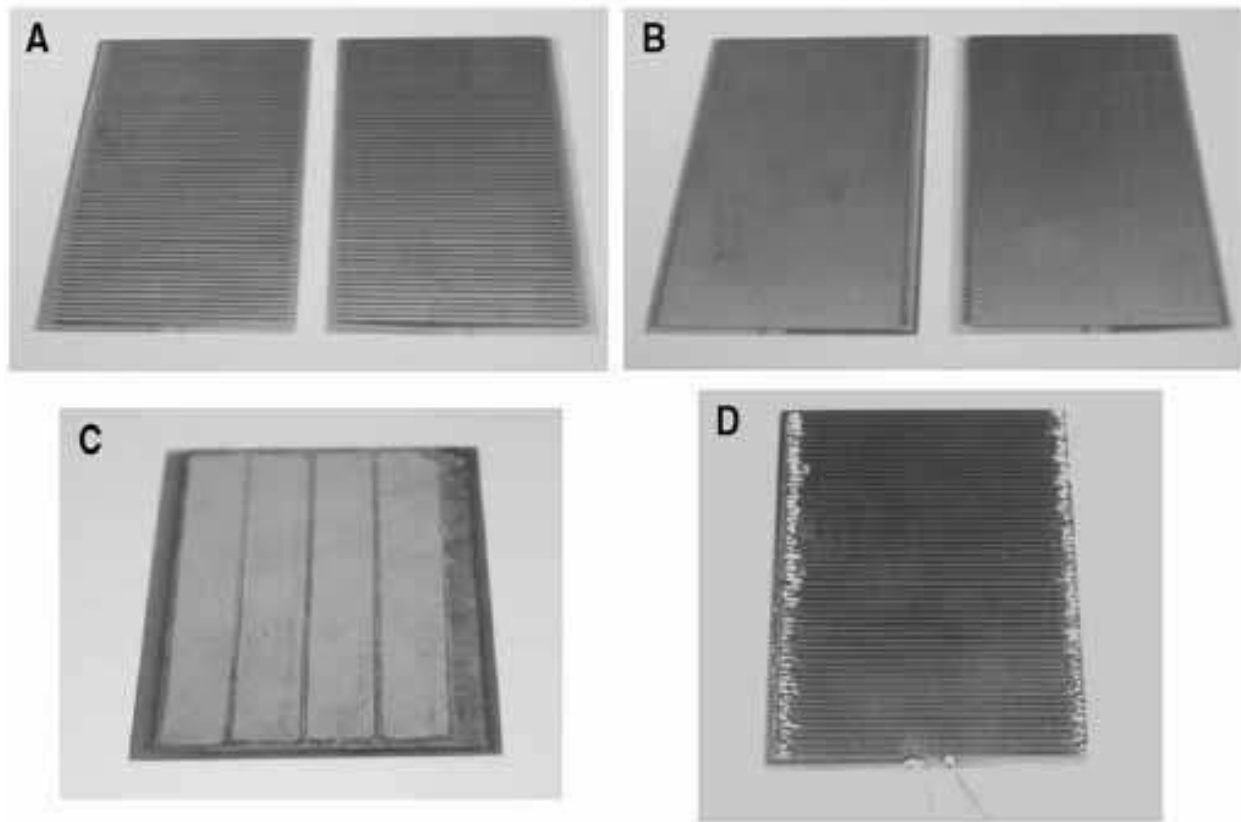

Fig. 7. Photographs of the PCBs used to fabricate the tag. A and B: before the electrodeposition of the magnetic material. C: one of the PCBs with the electrodeposited magnetic material. D: the card after soldering the tracks of both PCBs.

Magnetic core

We have electrodeposited CoP multilayers to fabricate the magnetic core of the tag. These multilayers are particularly useful due to their low coercivity and high permeability. CoP monolayers exhibit perpendicular to plane magnetic anisotropy. It means that the material is difficultly magnetized in plane. However, $\text{Co}_x\text{P}_{1-x}$ multilayered films with different composition within the span ($0.74 < x < 0.86$) show soft magnetic properties: i) in-plane magnetic anisotropy; ii) low coercivity; and iii) high permeability (Perez et al., 2000).

The total thickness of the multilayer was $40 \mu\text{m}$. It is formed by the stacking $(\text{Co}_{0.74}\text{P}_{0.26}/\text{Co}_{0.83}\text{P}_{0.17})_N$ bilayers with each layer of 20nm . This two compositions were selected in order to have amorphous alloys covering all the substrate (Ciudad Rio-Perez et al., 2008).

$(\text{Co}_{0.74}\text{P}_{0.26}/\text{Co}_{0.83}\text{P}_{0.17})_N$ multilayered amorphous films were electrodeposited on Cu substrates under the conditions referred in (Perez et al., 2000). It was used an Autolab-PGSTAT30 potentiostat/galvanostat to control the current density. The electrolyte was: CoCO_3 (39.4 g/l - 0.33M), $\text{CoCl}_3 \cdot 6\text{H}_2\text{O}$ (181 g/l - 0.76M), H_3PO_3 (65 g/l - 0.76M), and H_3PO_4 (50 g/l - 0.51M). The temperature of the electrolyte during the deposition was 80°C . It was used a 99.9% chemical purity Co anode. The density of the electrical current needed to deposit $\text{Co}_{0.74}\text{P}_{0.26}$ was $100 \text{ mA}/\text{cm}^2$ whereas for $\text{Co}_{0.83}\text{P}_{0.17}$ was $500 \text{ mA}/\text{cm}^2$.

Electronics of the tag

In a first approach, the electronics of the tag was designed in two different modules: one for powering and another for communications. See Figure 8. The module for powering is an

analog multiplier circuit. Some different capacitors are charged due to the induced e.m.f in the winding of the tag. The module for communications is formed by a microcontroller that provides control signals (0/1) to the gate of a MOSFET. This MOSFET acts like a switch to open and short-circuit the winding. The communication module is also similar to an analog multiplier circuit in which some capacitors have been removed in order to improve the response time. As microcontroller we have used a PIC16LF84A from MicroChip. It can be powered by only 2V and it can work with only 15 μ A.

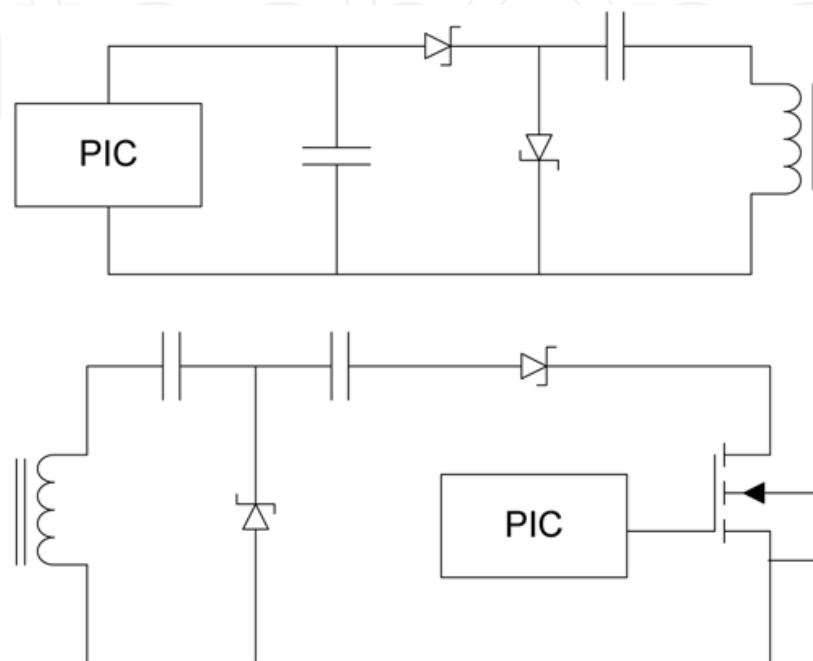

Fig. 8. Initial designs for the electronics of the tag. Up: module to power the PIC. Down: module for communications.

The inductive coupling-based RFID systems use to include a Zener diode 5V6 to protect the circuit of the tag from high voltages when approaching it to the antenna. In our case, this protection is not needed because the voltage is limited by the capacitors.

In a later stage, we simplified these circuits by unifying both modules as shown in Figure 9.

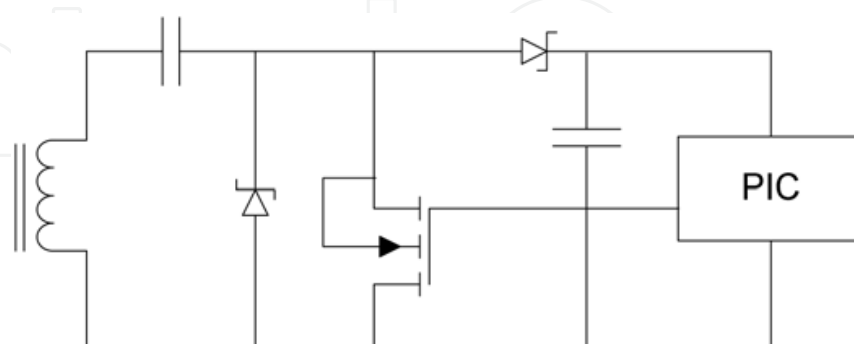

Fig. 9. Simplified electronics of the tag for powering and communications.

3.2.2 Reader

The reader is a tuneable magnetic field sensor. It detects the change in the magnetization of the tag due to the switching of the winding. The magnetic sensor must be tuned at the

frequency of the magnetization of the tag. This frequency is that of the applied magnetic field by the antenna.

The best option is to use a fluxgate and the double demodulation in phase technique (Aroca et al., 1995).

Fluxgate

A fluxgate is formed by a soft magnetic core and two different windings. The primary or excitation winding generates a magnetic field able to saturate periodically in both polarities the magnetic core. In the secondary or pickup winding is induced an e.m.f. The amplitude of the second harmonic of the e.m.f. in the secondary winding is proportional to any external magnetic field. The sensitivity of the fluxgates spans in the range 10^{-10} to 10^{-4} T. A good introduction to fluxgate sensors can be found in (Ripka, 2001).

We have used two different fluxgates. A common one described in (Aroca et al., 1995) and a planar one described in (Perez et al., 2004). The last one is particularly interesting because it is fabricated in PCB technology and its magnetic core is electrodeposited.

Double demodulation in phase

Figure 6 shows the demodulation technique used in the RFID system. All signals for excitation and sensing are obtained from the same frequency source. The primary winding is excited by an AC current with frequency f . A first lock-in amplifier is used to select the second harmonic of the signal induced in the secondary winding of the fluxgate sensor (frequency $2f$). The time constant must be carefully selected so that the amplitude of the second harmonic, as well as any change due to the presence of the tag in the surroundings, can be measured.

If the tag is magnetized with frequency f_m ($f_m \ll f$) by the applied magnetic field, the amplitude of the signal after the first lock-in amplifier is modulated at this frequency. A second lock-in is used to demodulate the output signal of the first lock-in amplifier. The reference frequency for the second one is f_m .

3.2.3 Antenna

It produces the AC magnetic field to power the tag and magnetize the magnetic material in it. The antenna must also provide of an area in which the magnetic field is compensated. This area is needed to place the reader avoiding its magnetic saturations due to the applied magnetic field. Different antennas can be designed. We have successfully proved two different geometrical arrangements.

Antenna for a standard fluxgate

The first design of the antenna was a Helmholtz pair of coils with both coils connected in opposition. Figure 10. The fluxgate is placed centred in between the two coils. In this area the magnetic field is zero. We have used a standard fluxgate with a 12 kHz excitation signal. Applying an AC magnetic field of only 1 gauss of amplitude and 1.9 kHz of frequency, the reader is able to detect the signal of the tag even through an aluminium folder and in close contact to the tag and with a thickness up to 0.2 mm.

The magnetic field as a function of the distance for this antenna is given in (Ciudad et al., 2004).

Antenna for a planar-type fluxgate

The antenna for the planar fluxgate is also planar. Figure 10. This antenna can be fabricated in PCB technology. It is formed by two spiral and planar windings. They are connected to

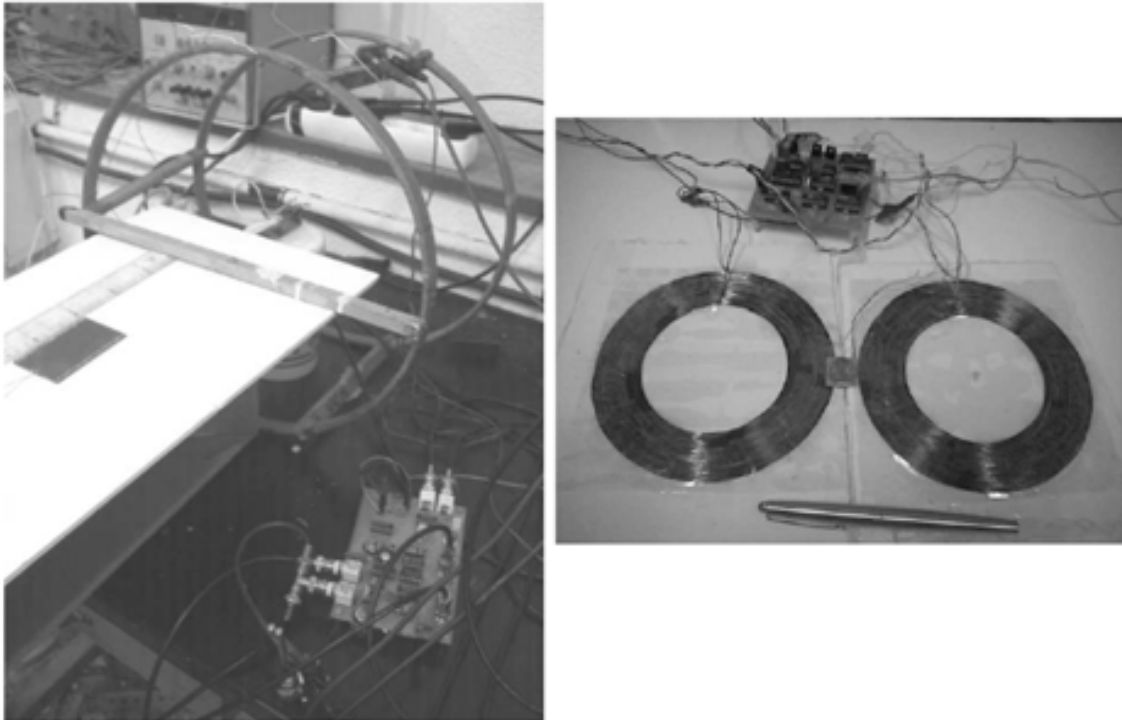

Fig. 10. Different designs for the antenna. Left: antenna for a standard fluxgate. The fluxgate is centred in the Helmholtz coils. Right: antenna for a planar one. The fluxgate is between the planar coils.

compensate the magnetic field they produce in the area in between them. This is the place to fix the fluxgate. Both windings have been done using a copper fill of 1 mm of diameter. Each spiral has 25 turns. The inner radius is 3.5 cm and the outer one 7.5 cm. The distance in between their centres is 18 cm. The magnetic field produced by this antenna as a function of the distance is given in (Ciudad Rio-Perez et al., 2008).

This RFID system works with an AC magnetic field of only 5 gauss of amplitude and 6 kHz of frequency.

3.3 Experimental testing

The system has been tested for the different fluxgates and antennas. It can work through metals at very low frequencies down to the 1 kHz order. This is two orders of magnitude below the working frequency of the inductive coupling-based systems.

Some of the signals produced in the different parts of the system are shown below. They have been taken from the system with planar fluxgate and antenna.

Figure 11 shows the voltage at the winding of the tag. Zero voltage is obtained when the microcontroller short-circuits the winding.

The output signal from the first lock-in amplifier is shown in Figure 12. This signal is proportional to the amplitude of the second harmonic of the induced e.m.f. in the pickup winding of the fluxgate. The amplitude of the second harmonic changes with frequency f_m due to the presence of the tag. In addition, this AC signal is modulated due to the change of the magnetization of the magnetic material when the microcontroller opens and shortcircuits the winding. Therefore, the low frequency modulation is produced by the switching of the winding of the tag. Compare Figures 11 and 12.

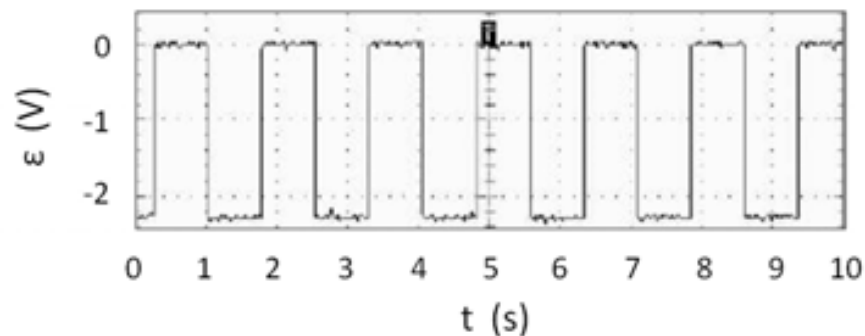

Fig. 11. Signal in the winding of the tag.

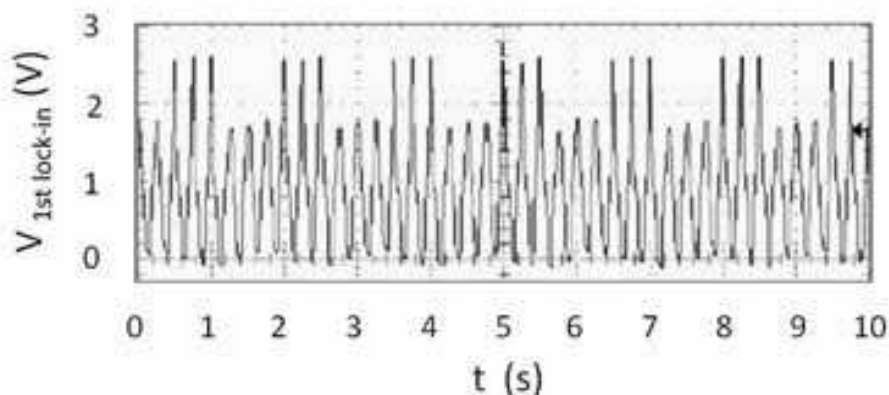

Fig. 12. Signal in the reader after the demodulation in the first lock-in amplifier.

Figure 13 shows the signal after the second lock-in amplifier. It has the same frequency that the signal produced by the microchip in the tag. It means that a signal with the same frequency that the produced in the PIC of the tag has successfully obtained in the reader.

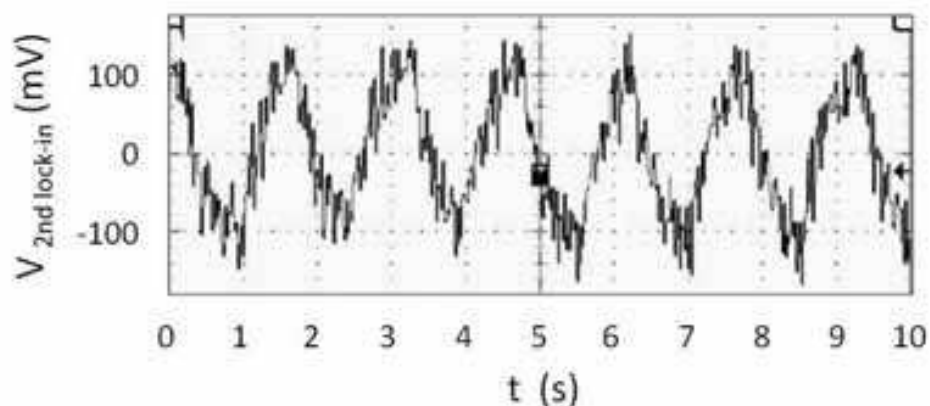

Fig. 13. Signal in the reader after the demodulation in the second lock-in amplifier.

These graphs (Figures 11, 12 and 13) clearly show that the microcontroller in the tag can be powered by a low frequency magnetic field and it can send information. They also show that the fluxgate with the second in-phase demodulation has successfully used as a reader.

3.4 Theoretical model

In (Ciudad Rio-Perez et al., 2008) it is given an accurate model to calculate the distance limitation of the ULF RFID system for a particular application. The model is also compared

with experimental data. This distance limitation can be due to failures in the detection or in powering the tag.

3.4.1 Detection of the tag: minimum sensitivity of the reader (fluxgate sensor).

The magnetic field in the tag position H_{ex} is assumed to be sinusoidal with amplitude H_0 and angular frequency ω :

$$H_{ex} = H_0 e^{j\omega t} \quad (5)$$

The magnetic flux through the tag and the induced e.m.f. in the winding are easily calculated. See (Ciudad Rio-Perez et al., 2008) for a detailed deduction. This e.m.f. is used to charge the capacitors that power the microcontroller. When the PIC in the tag short-circuits the winding, the induced e.m.f. gives rise to the flow of a current through the winding. This current causes a magnetic field. The total magnetic field (H_R) that magnetizes the magnetic core of the tag is the addition of the magnetic fields produced by the antenna (H_{ex}) and the winding (H_{tag}). The total magnetic field is:

$$H_R = \left(1 - \frac{1}{1 + \frac{R}{j\omega L}} \right) H_{ex} \quad (6)$$

R is the resistance of the winding of the tag and L its inductance. When the microcontroller opens the winding, $R = \infty$ and the magnetization of the magnetic core of the tag is given by:

$$M_{open} = \chi H_{ex} \quad (7)$$

χ is the magnetic susceptibility of the magnetic core. However, when this winding is shortcircuited, the magnetic core is not magnetized because $R=0$ and then $H_R = 0$. Therefore, being V the volume of the magnetic core, the change in the magnetic moment of the tag is given by:

$$\Delta m = \chi H_{ex} V \quad (8)$$

If a shielding layer of thickness t_s , conductivity σ and magnetic permeability μ_s is placed between the excitation system and the tag, the magnetic field is attenuated according the Skin's formula (5):

$$\Delta m = \chi H_{ex} V e^{-t_s \sqrt{\frac{\mu_s \sigma \omega}{2}}} \quad (9)$$

The tag is supposed to behave like a magnetic dipole. It implies that the magnetic field produced by the tag is reduced with the cube of the distance to the tag. This behaviour has been experimentally checked. See Figure 13.

The change of the magnetic field ΔH_{tag} when opening and short-circuiting the winding, at a distance r_t along its axis and at the other side of the shielding wall, is given by:

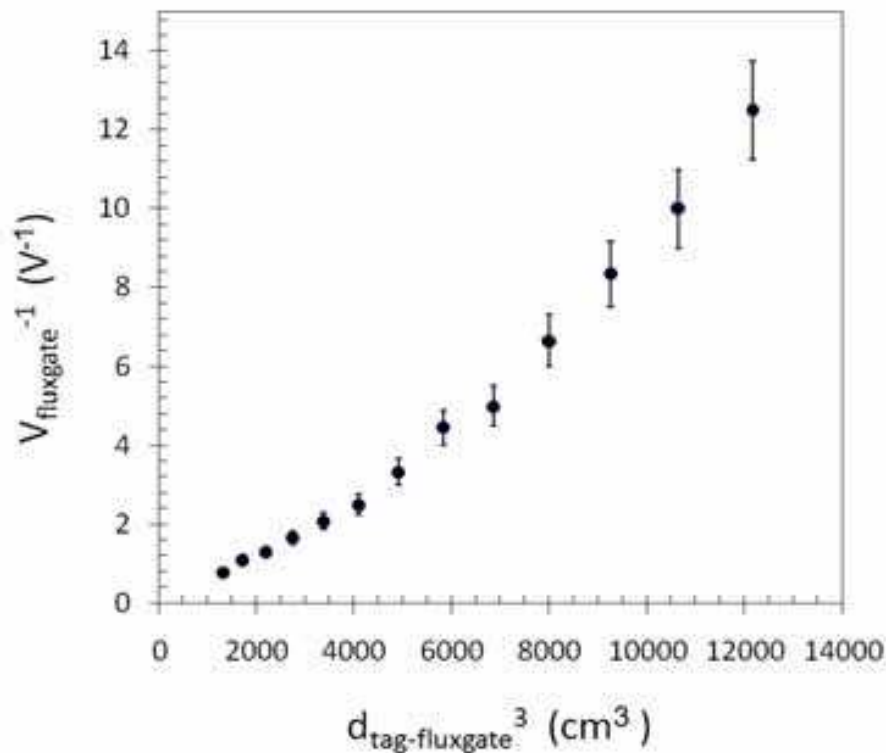

Fig. 13. Change of the signal in the pickup winding of the fluxgate V_{fluxgate} when opening and short-circuiting the winding of the tag as a function of the distance between the tag and the fluxgate. Notice that $V_{\text{fluxgate}} \propto \Delta H_{\text{tag}}$. The relation $V_{\text{fluxgate}}^{-1} \propto d_{\text{tag-fluxgate}}^3$ is characteristic of the dipolar behaviour.

$$\Delta H_{\text{tag}} = e^{-t_s \sqrt{\frac{\mu_s \sigma \omega}{2}}} \frac{\Delta m}{2\pi r_t^3} = \frac{\chi H_{\text{ex}} V}{2\pi r_t^3} e^{-2t_s \sqrt{\frac{\mu_s \sigma \omega}{2}}} \quad (10)$$

This expression gives the minimum sensitivity of the fluxgate sensor that is needed in order to detect the tag at a distance r_t and through the shielding. This expression is in good accordance with our experimental measurements (Ciudad Rio-Perez et al., 2008).

3.4.2 Powering of the tag

Using any low-power microcontroller like a PIC16F84 from Microchip (working parameters: $\varepsilon = 2$ V and $I = 15$ μ A at 32 kHz), the main limitation of the system is the maximum distance at which the induced e.m.f. in the tag is able to power its electronics. The r.m.s. value of the e.m.f. in the tag is given by:

$$\varepsilon_m = \omega \mu n S \frac{H_0}{\sqrt{2}} e^{-t_s \sqrt{\frac{\mu_s \sigma \omega}{2}}} \quad (11)$$

Formula (11) is in good accordance with the experimental values (Ciudad Rio-Perez et al., 2008). This simple model allows a proper design of the new RFID system for a particular application. Any particular arrangement of metals can be modeled by using an effective theoretical shielding.

4. Conclusions

Inductive coupling-based systems show different problems to work in the presence of metals. The low frequency (LF) systems can work with metals in the surroundings. However, they only can work through metals in some particular circumstances and designs. The different problems arising from metal non-cleaned surroundings have been showed in section 2. All these problems could be avoided if the working frequency is reduced. However, the inductive coupling becomes inefficient quickly.

We have developed and experimentally tested a new system to work through metals. It is shown in Section 3. It works at ultra low frequencies (1 - 100 kHz) and through metals. The new RFID system works without any resonant circuit. It is based on measuring changes of the magnetization of a magnetic core included in the tag. Different geometrical arrangements for the antenna and the reader have been designed. This is of importance since the magnetic fields produced by these antennas have different directions in the position of the tag. The characteristics of the antennas can be checked in (Ciudad et al., 2004) and (Ciudad Rio- Perez et al., 2008). A combination of those antennas will allow to avoid any directional problem. In addition, we give a theoretical model of the system. It allows a better design of the system for any particular application.

In section 3.4 it is explained a theoretical model of the system. According to this model and our experimental data, the work distance is bellow 0.4 m for a typical antenna and low intensity magnetic fields. The system has demonstrated to be able to work through aluminium layers with thicknesses up to 0.2 mm and in close contact to the tag.

Table 1 summarizes the characteristics of LF and ULF systems. The comments are relative to the different RFID systems. Some similar tables for other RFID systems can be found in (Wilding & Delgado, 2004) and references therein.

5. References

- Aroca, C.; Prieto, J.L.; Sanchez, P.; Lopez & Sanchez, M.C. (1995). Spectrum analyzer for low magnetic field, *Review of Scientific Instruments*, 66, (1995) 5355-5359
- Balanis, C.A. (1997). *Antenna theory: analysis and design* (2nd). John Wiley & Sons Publisher, 0- 471-59268-4, New York
- Bovelli, S.; Neubauer, F. & Heller. (2006). C. A novel antenna design for passive RFID transponders on metal surfaces, Proceedings of the 36th European Microwave Conference, pp 580-582, September 2006, Manchester UK
- Bottomley, P.A. & Andrew, E.R. (1978). RF field penetration, phase shift and power dissipation in biological tissue: implications for NMR imaging, *Phys. Med. Biol.* 23 (1978) 630-643.
- Bowler, N. & Huang, Y. (2005). Electrical conductivity measurement of metal plates using broadband eddy-current and four-point methods. *Measurement Scientific Technology*. 16 (2005) 2193-2200
- Ciudad, D.; Perez, L.; Sanchez, P.; Sanchez, M.C.; Lopez, E. & Aroca, C. (2004). Ultra low frequency smart cards, *Jurnal of electrical engineering*, 55, 10/S, (2004) 58-61.
- Ciudad Rio-Perez, D.; Arribas, P.C.; Aroca, C. & Sanchez, P. (2008). Testing thick magnetic shielding effect on a new low frequency RFIDs sytem. *IEEE Transaction on Antennas and propagation*, 56, 12 (December 2008) 3838-3843
- Dixon, P.F.; Carpenter, M.P.; Osward, M.M. & Gibbs, D.A. (2007). *RFID Tags*, US Patent 7205898, April 17 2007
- Dixon, P.F.; Carpenter, M.P.; Osward, M.M. & Gibbs, D.A. (2008). *RFID tags having improved read range*, US Patent 7378973, May 27 2008

	ULF System	LF Systems
Physical principle	Fluxgate magnetometry	Inductive coupling
Work frequency	1 kHz-100 kHz	125-134 kHz
Range	<0.4m (non-resonant configuration)	< 1m
Size issues	Small size (due to the use of fluxgates)	Large size
Data transfer rate	Very slow	Slow
Metals: in the surroundings	No problem	No problem (some design issues)
Metals: wrapping the tag	No problem. Distance range reduced	Only under very particular circumstances
Prize: Antenna	High	High
Prize: Tag	High (since it contains magnetic material)	Low
Sensors	The tag can power sensors connected to it as well as send the measurements.	Sensors cannot be powered by the RFID system
Applications	Any system having problems with metals and no high data transfer ratio requirements.	Animal tracking. Item tracking. Product identification. Car key.

Table 1. Comparison of the characteristics of LF and ULF systems.

- Dobkin, D.M. & Weigan S.M. (2005) Environmental effects on RFID tag antennas, *2005 IEEE MTT-S International Microwave Symposium Digest*, pp. 135-138, 0-7803-8845-3, June 2005, Long Beach-California, IEEE
- EM Microelectronic. (2002). *AppNote 411: RFID Made Easy*. EM Microelectronic - Marin SA, September 2002
- Finkenzeller, K. (2003). *RFID Handbook (2nd)*, John Wiley & Sons Publishers, 0-470-84402-7, West Sussex
- Hoeft, L.O. & Hofstra J.S. (1988). Experimental and theoretical analysis of the magnetic field attenuation of enclosures, *IEEE Transactions on electromagnetic compatibility*, 30, 3 (August 1988), 326-340, 0018-9375
- Ida, N. & Bastos, J.P.A. (1997). *Electromagnetics and calculations of fields (2nd)*, Springer-Verlag, ISBN 0-387-94877-5, New York
- Lide, D R. (ed.). (2009). *CRC Handbook of Chemistry and Physics*, 89th Edition (Internet version 2009), CRC Press, Taylor and Francis, Boca Raton, F.L.
- Perez, L.; de Abril, O.; Sanchez, M.C.; Aroca, C.; Lopez, E. & Sanchez, P. (2000). Electrodeposited amorphous CoP multilayers with high permeability, *Journal of magnetism and magnetic materials*, 215-216 (2000) 337-339
- Perez, L.; Aroca, C.; Sanchez, P.; Lopez, E. & Sanchez, M.C. (2004). Planar fluxgate sensor with an electrodeposited amorphous core, *Sensors Actuators A*, 109 (2004) 208-211
- Ripka, P. (ed.) (2001). *Magnetic sensors and magnetometers*, Artech House Inc., 1-58053-057-5, Norwood
- Wilding, R. & Delgado, T. (2004). RFID demystified: Part 1 The technology, benefits and barriers to implementation, *Logistic & Transport Focus*, 6, 3 (2004) 26-31

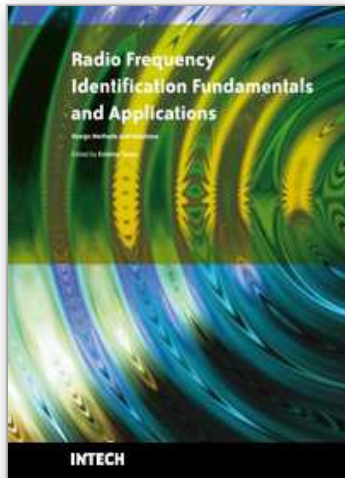

Radio Frequency Identification Fundamentals and Applications Design Methods and Solutions

Edited by Cristina Turcu

ISBN 978-953-7619-72-5

Hard cover, 324 pages

Publisher InTech

Published online 01, February, 2010

Published in print edition February, 2010

This book, entitled Radio Frequency Identification Fundamentals and Applications, Bringing Research to Practice, bridges the gap between theory and practice and brings together a variety of research results and practical solutions in the field of RFID. The book is a rich collection of articles written by people from all over the world: teachers, researchers, engineers, and technical people with strong background in the RFID area. Developed as a source of information on RFID technology, the book addresses a wide audience including designers for RFID systems, researchers, students and anyone who would like to learn about this field. At this point I would like to express my thanks to all scientists who were kind enough to contribute to the success of this project by presenting numerous technical studies and research results. However, we couldn't have published this book without the effort of InTech team. I wish to extend my most sincere gratitude to InTech publishing house for continuing to publish new, interesting and valuable books for all of us.

How to reference

In order to correctly reference this scholarly work, feel free to copy and paste the following:

D. Ciudad, P. Cobos Arribas, P. Sanchez and C. Aroca (2010). RFID in Metal Environments: An Overview on Low (LF) and Ultra-Low (ULF) Frequency Systems, Radio Frequency Identification Fundamentals and Applications Design Methods and Solutions, Cristina Turcu (Ed.), ISBN: 978-953-7619-72-5, InTech, Available from: <http://www.intechopen.com/books/radio-frequency-identification-fundamentals-and-applications-design-methods-and-solutions/untitrfid-in-metal-environments-an-overview-on-low-lf-and-ultra-low-ulf-frequency-systems>

INTECH
open science | open minds

InTech Europe

University Campus STeP Ri
Slavka Krautzeka 83/A
51000 Rijeka, Croatia
Phone: +385 (51) 770 447
Fax: +385 (51) 686 166
www.intechopen.com

InTech China

Unit 405, Office Block, Hotel Equatorial Shanghai
No.65, Yan An Road (West), Shanghai, 200040, China
中国上海市延安西路65号上海国际贵都大饭店办公楼405单元
Phone: +86-21-62489820
Fax: +86-21-62489821

© 2010 The Author(s). Licensee IntechOpen. This chapter is distributed under the terms of the [Creative Commons Attribution-NonCommercial-ShareAlike-3.0 License](#), which permits use, distribution and reproduction for non-commercial purposes, provided the original is properly cited and derivative works building on this content are distributed under the same license.

IntechOpen

IntechOpen