

We are IntechOpen, the world's leading publisher of Open Access books Built by scientists, for scientists

4,800

Open access books available

122,000

International authors and editors

135M

Downloads

Our authors are among the

154

Countries delivered to

TOP 1%

most cited scientists

12.2%

Contributors from top 500 universities



WEB OF SCIENCE™

Selection of our books indexed in the Book Citation Index
in Web of Science™ Core Collection (BKCI)

Interested in publishing with us?
Contact book.department@intechopen.com

Numbers displayed above are based on latest data collected.

For more information visit www.intechopen.com



Near Field On Chip RFID Antenna Design

Alberto Vargas and Lukas Vojtech
*Czech Technical University in Prague
 Czech Republic*

1. Introduction

This chapter deals with the designing strategy and process integration for a small On-Chip-Antenna (OCA) with a small Radio Frequency Identification (RFID) tag on a chip-area 0.64×0.64 mm at 2.45 GHz for communication in near field. On the other hand, communication between Reader device and set of OCA-Tag is based on inductive coupling.

Embedded antenna is an important step down into the route of miniaturisation. A special micro-galvanic process that can take place on a normal CMOS wafer makes it possible. The coil could be placed directly onto the isolator of the silicon chip in the form of a planar (single layer) spiral arrangement and contacted to the circuit below by means conventional openings in the passivation layer (e.g., Usami, 2004). Dimension of the conductor flows in the range of $5\text{-}10 \mu\text{m}$ with a layer thickness of $15\text{-}30 \mu\text{m}$ (Finkenzeller, 2003).

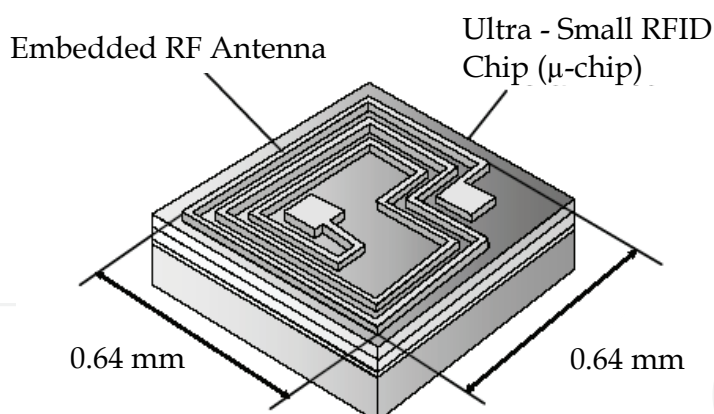

Fig. 1. Embedded antenna structure of ultra-small RFID chip.

RF signal can be radiated effectively if the linear dimension of the antenna is comparable with the wavelength of the operating frequency; however, the wavelength at 2.45 GHz is 12.24 centimetres. Due the size minimization of the transponder (reducing its area), a loop antenna in the shape of a coil that is resonating have to be used. Since the operating read range of these tags is relatively small compared to a wavelength, they operate in the near-field radiation region. The tag made up of OCA is preferred to save a major portion of the assembly cost in fabrication and it also enhances the system reliability.

Design strategy and communication principles are introduced by the description of its equivalent circuit parameters. The next step is matching network design and simulation

Source: Radio Frequency Identification Fundamentals and Applications, Design Methods and Solutions, Book edited by: Cristina Turcu, ISBN 978-953-7619-72-5, pp. 324, February 2010, INTECH, Croatia, downloaded from SCIYO.COM

based on the complex impedance of real RFID chip EM4222 and silicon chip materials constants. These preliminary steps are presented, the OCA structure design, simulation and final dimension optimisation duties are performed.

The resulting OCA transponder with an integrated antenna implemented on the chip thus requires only approx. 0.64 mm² of silicone. Its small dimensions allow for expansion of applications used for marking various miniature objects as e.g. minicontainers for chemical or biological samples. Economical and application reasons force us to modify the existing object marking technologies. One of the development trends is the miniaturization of identifiers, and especially the reduction of their price. Low price and miniaturization allow for production of new RFID technology applications.

2. Tag antenna design

The efficiency of the antenna is limited by its allowable area, which is simply determined by the underlying tag chip area. The antenna for backscattering model is a far-field one (dipole, slot or patch antenna) and its typical dimension should be $\lambda/2$ or $\lambda/4$. Understanding a symbol λ as wavelength. According to these, the size of the antenna should be around several centimetres. Since the chip dimension is about micrometers, it is too small to use the backscattering model although it is widely used in 2.45 GHz. In comparison, with an inductive-coupling model, the dimension of the inductor coils can be very small as in mm range. Therefore, OCA antenna becomes the best suitable technology to embed into Chip.

As magnetic-coupling model, OCA should be a coil on the Tag, a portion of the transformer, constructed together with another coil of the Reader collectively, based on Inductive Coupling technology as shown in figure 3. The tag either receives energy from the Reader or communicates the signal to Reader through those two coils. High coupling efficiency, or communication efficiency between the Reader and Tag, can be obtained by optimizing the design of the antenna coils. In addition to these, OCA's coil needs to be designed with a large inductive reactance, in order to obtain a high electric potential induced under a given intensity of magnetic field, generated by the Reader's antenna.

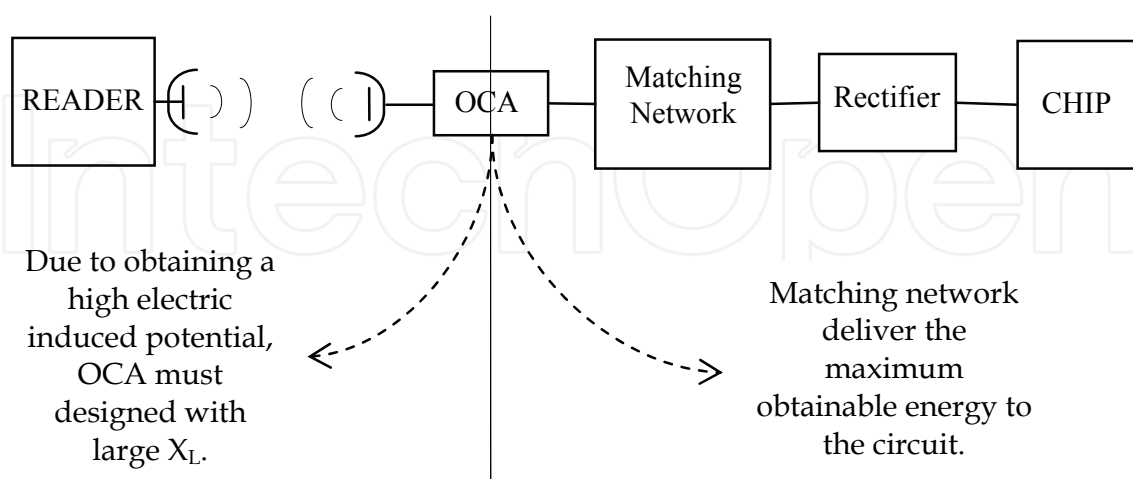

Fig. 2. Model scheme of the circuit to design

Going in depth into the entire design of the receiver part or the Tag, as shown in figure 2, antenna, matching network and doubler rectifier in series are implemented. The antenna

must be matched with the input impedance of the subsequent circuit, Z_{RC} , in order to deliver the maximum obtainable energy to the Chip. Furthermore, this Matching Network has to be only constructed from capacitors since inductors will share the energy in OCA and thus reduce the efficiency of the coil. On the other hand, selected Chip contains Doubler Schottky rectifier (Prat, 1999) and internal capacitance, which are responsible for converting AC signal into DC. Indeed, not only rectifier capacitance is usually assumed integrated, but also parasitic capacitances of the Tag's Chip material.

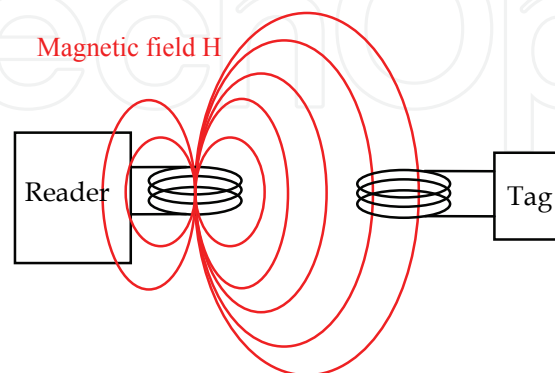

Fig. 3. Scheme of the Inductive Coupling Technology.

In terms of analysis, load process of the Chip is often modelled by a resistance at its highest current usage (Atmel, 2002) at power-up reset or during an EEPROM write.

Keeping the resistance of the coil to the minimum permits to enhance the quality factor, Q , of the antenna and increase the available energy to the Tag. In order to obtain the high electric potential induced, OCA must be designed with a large inductive reactance. Furthermore, OCA must be fabricated of a required Q -factor performance to satisfy the matching, and a rate around 3 is assumed (Guo et al, 2006).

2.1 Parameters

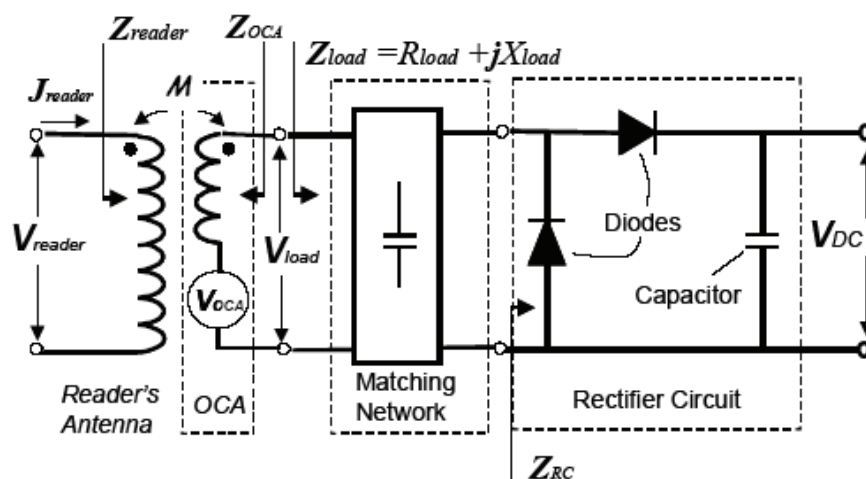

Fig. 4. Schematic diagram of the Reader and the Tag.

Figure 4 shows the equivalent circuit where the Reader and the Tag antennas are magnetically coupled via mutual inductance, M . The parallel resonant circuit of the antenna's Tag includes the inductance of the loop, L_{OCA} , and as well, its own impedance Z_{OCA} (1).

$$Z_{OCA} = R_{OCA} + j X_{OCA} \quad (1)$$

Voltage induced in the antenna, V_{OCA} , involves both the Tag and the Reader coils in a linear expression, as it can be check in formula 2. J_{reader} is the current throughout the Reader's antenna.

$$|V_{OCA}| = \omega K \sqrt{L_{reader} L_{antenna}} J_{reader} \quad (2)$$

Where ω is the circular frequency ($\omega = 2\pi f$) and K is the coupling coefficient between OCA and reader's antenna. Power delivered to the Chip (3), understanding loading stage (figure 4) as the set of Matching network, Double rectifier, the Chip and its input voltage is assumed as follows:

$$P_{load} = \frac{1}{2} |V_{OCA}|^2 \frac{R_{load}}{(R_{load} + R_{OCA})^2 + (X_{load} + X_{OCA})^2} \quad (3)$$

$$V_{load} = \frac{R_{load} + jX_{load}}{(R_{OCA} + R_{load}) + j(X_{OCA} + X_{load})} \cdot V_{OCA} \quad (4)$$

In terms of design process, when the Chip is properly matched with the antenna coil (5), the maximum voltage (7) and power (6) is delivered to the load.

$$Z_{OCA} = Z_{load}^* \quad (5)$$

$$P_{load \max} = \frac{1}{8} \frac{|V_{OCA}|^2}{R_{OCA}} = \frac{1}{8} \frac{|V_{OCA}|^2}{R_{load}} \quad (6)$$

$$|V_{load \max}| = \frac{1}{2R_{OCA}} \sqrt{R_{OCA}^2 + X_{OCA}^2} \cdot |V_{OCA}| \quad (7)$$

According to the Power maximum load and the theory of the Q -factor in the resonant LC circuit, detailed below in section 4.1, both factors can be expressed in function of each other. Thus, the voltage supplied to the load depends on the voltage of the OCA. Achieving a higher Q -factor is faced, and 3 is assumed optimal value as reported in the initial part of this section.

$$P_{load \max} = \frac{1}{8} \frac{|V_{OCA}|^2}{R_{OCA}} \cdot Q_{OCA} \quad (8)$$

$$|V_{load}| = \frac{1}{2} \sqrt{1 + Q_{OCA}^2} \cdot |V_{OCA}| \quad (9)$$

Finally, signal amplitude on the Reader side, ΔV_{reader} , which is sent back from the Tag to the Reader is proportional to the current throughout the Reader's antenna and the OCA's Q -Value:

$$\Delta V_{reader} = \frac{1}{2} \frac{\omega^2 M^2 Q_{OCA}}{X_{OCA}} \cdot J_{reader} \quad (10)$$

3. Circuit modelling

The suggested design scenario starts with co-designing of the reader's antenna (L_{reader}) and OCA (L_{OCA}) based on the available fabrication technology to meet the required specifications. Besides, Q-factor for the power conversion is specified on the based of three-dimensional electromagnetic simulation would determine the Tag's efficiency. Matching Network between OCA and Chip takes an important stage and it is considered through checking the input impedance of the circuit. Overall, goals must meet according to the specifications provided by manufacturer of the Chip.

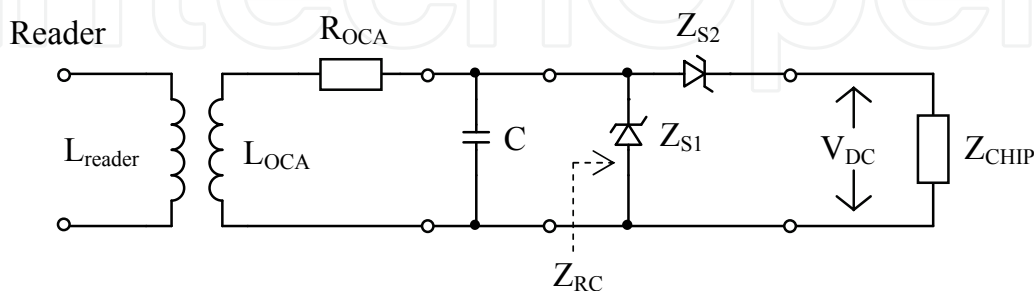

Fig. 5. Equivalent Schematic made by lumped elements

3.1 Design goals

Maximum power at the entrance of the Chip from the reader's antenna takes an important requirement to face within design process of the antenna. It is a full duplex system; this means that Tag must be designed to receive and send data, allowing signal communication between Reader and Chip. The RFID antenna receives signal from the reader's antenna and the signal is powering the Chip when OCA delivers voltage enough to wake up the Integrated Chip. In transmitting mode, Chip is serving as a source and also responsible for sending out its stored data through the RFID antenna. The most important and critical design-procedure is transmitting part, to such an extend if the best results in this mode are achieved, there are also the best outcomes in receiving mode.

The most important tag performance characteristic is read range. One limitation on the range is the maximum distance from which the tag receives just enough power to turn on from the reader. Another limitation is the maximum distance from which the reader can detect this signal from the tag. The read range is the smaller of two distances (typically, the first one since RFID reader sensitivity is usually high). Because reader sensitivity is typically high in comparison with the tag, the read range is defined by the tag response threshold. Read range is also sensitive to the tag orientation, the material of the tag is placed on, and to the propagation environment. Theoretical read range depends on the power reflection coefficient and can be calculated using the Friis free-space formula as:

$$r_{\max} = \frac{\lambda}{4\pi} \sqrt{\frac{P_t G_t G_r (1 - |s|^2)}{P_{th}}} \quad (11)$$

where λ is the wavelength, P_t is the power transmitted by the RFID reader, G_t is the gain of the transmitting antenna ($P_t G_t$ is EIRP, equivalent isotropic radiated power), G_r is the gain of the receiving tag antenna, P_{th} is the minimum threshold power necessary to power up

the chip. Typically P_t , G_t , G_r and P_{th} are slow varying, and $|s|^2$ is dominant in frequency dependence and primarily determines the tag resonance. Received power in decibel, formula 12, where L_{system} is the system losses that need to be taken into account during the measurement. This includes the cable and connector losses, temperature differences that cause internal losses in the instruments (i.e. antenna + transceiver of reader and tag). Indeed, our main goal is to deliver the maximum power from the chip to the OCA during transmitting mode in terms of feeding our Tag; once internal impedance of the tag (Z_{RC} , figure 4 and 5) is known and the type of the antenna is chosen (coil), tuning step will support us to achieve the final goal in terms of matching dimension between OCA and Tag.

$$P_r = P_t - L_{system} + G_t + G_r + (1 - |s|^2) - 20 \log_{10} \left(\frac{4\pi}{\lambda} \right) - 20 \log_{10} (r_{max}) \quad (12)$$

4. Matching network

Initially, as discussed before, Antenna’s impedance is fixed to Tag’s conjugated one at the frequency working (5). Both in figure 6 and 7 are useful to locate the input impedance of the double rectifier plus Chip (IC); Smith Diagram has been used through Mixed Series and Parallel Connections software, v. 2.8. Parameters such as equivalent impedance, admittance, its series and parallel scheme and its location in the Z-Smith Chart can be observed.

$$Z_{RC} = 80 - j232 \quad (13)$$

OCA’s resistance must be kept as small as possible in order to get a higher Q-factor inductor coil antenna. Since capacitors are exclusively employed in the matching network and trying

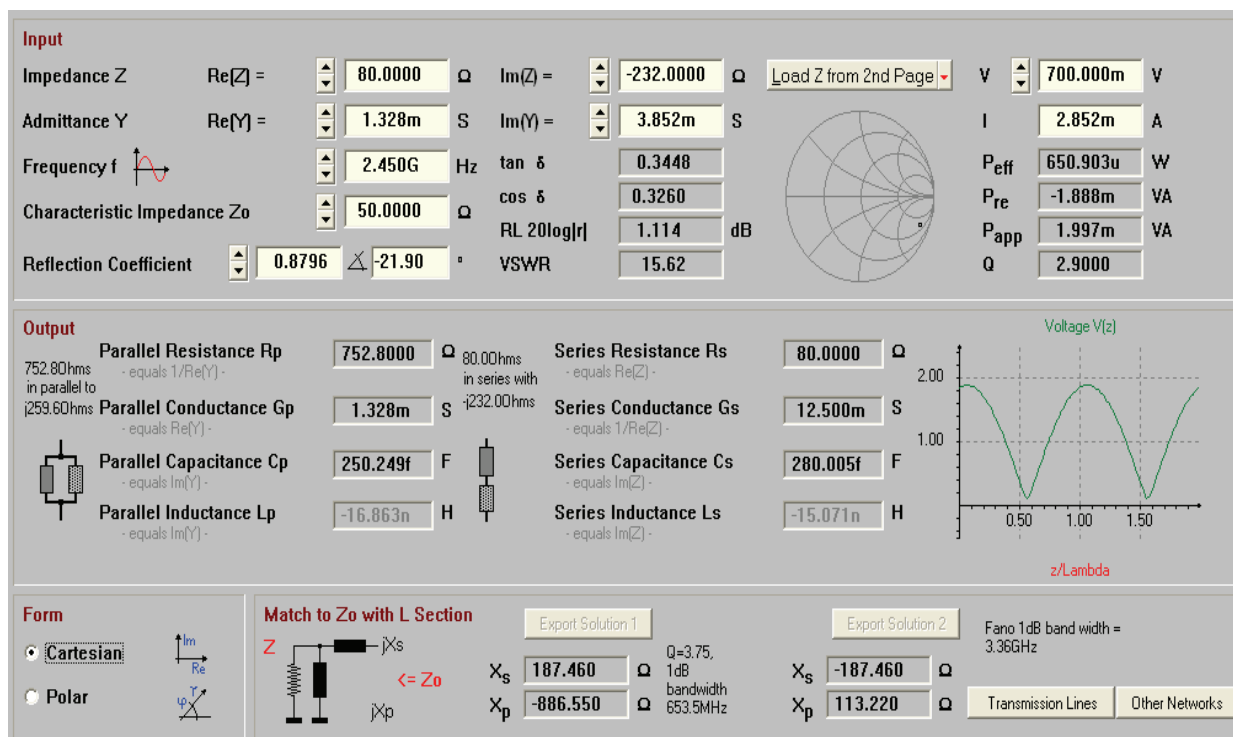

Fig. 6. Equivalent impedance, admittance, its series and parallel scheme and its location in the Z-Smith Chart at the frequency working 2.45 GHz. Characteristic impedance 50 Ω .

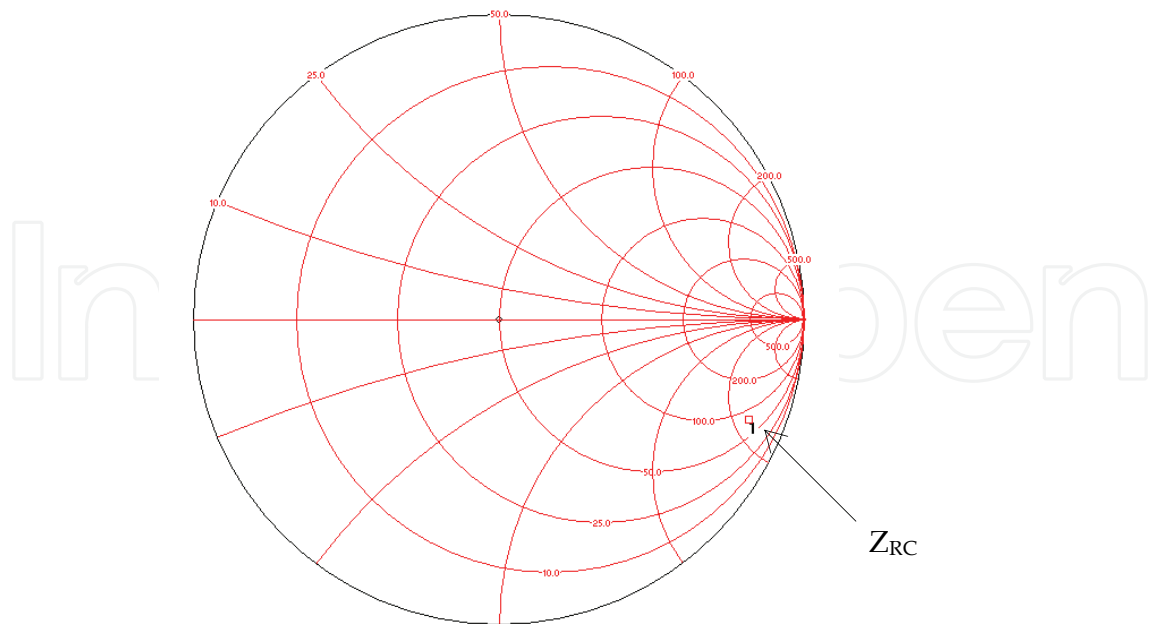

Fig. 7. Z-Smith Chart and the location of the input impedance of the RFID Tag used, Z_{RC} .

to get a good Q -factor of the OCA, suitable values for equivalent impedance will be computed and analyzed. Besides, capacitors influence only in imaginary part of the impedance within reactance part, but not in resistance. According to all of these OCA resistance can be designed equally to the Tag resistance, formula 14.

$$R_{OCA} = R_{RC} = 80 \Omega \quad (14)$$

On the other hand, relationship between reactance and resistance given below (15) together with Q -factor around 3, provide a consistent and a reliable design of OCA's impedance.

$$Q = \frac{X_{OCA}}{R_{OCA}} \approx 3 \rightarrow X_{OCA} \approx 3R_{OCA} \quad (15)$$

As a result, a consistent reactance for the tag antenna is $X_{OCA} \approx 240\Omega$ ($L_{OCA}=15.6nH$) is concluded. The impedance of OCA could be $Z_{OCA}=80+j240 \Omega$, and formula 16 shows the normalized value according to the characteristic impedance, which is located at the up-hemisphere of the Smith Chart, figure 8:

$$\overline{Z}_{OCA} = \frac{Z_{OCA}}{Z_0} \approx 1,6 + j4,6 \quad (16)$$

As it can be seen, OCA impedance has an inductive feature, which is coherent with the type of antenna, a coil. It is actually an inductive set by both the reader and the Tag coils. In this case, the matching area is the region inside of the Middle-Line and the frontier of the resistance and conductance in the down-hemisphere.

An ideal case would be if OCA antenna Impedance is exactly as the Chip input one; then no Matching network would be needed because both stages would be already matched, figure 9.

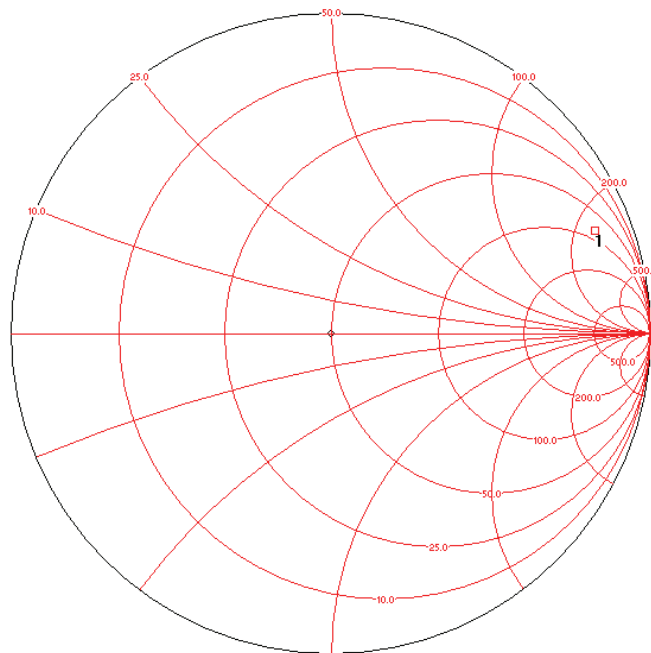

Fig. 8. DP-Nr. 1 ($80.0 + j240.0\Omega$, $Q = 3.0$ at 2.450 GHz.

Data Number Point	Impedance Ω	Q-Factor
1	$80-j240$	2.9
2	$80+j240$	2.9

Table 1. Data Point Numbers with its corresponding impedance and Q-factor at 2,45 GHz.

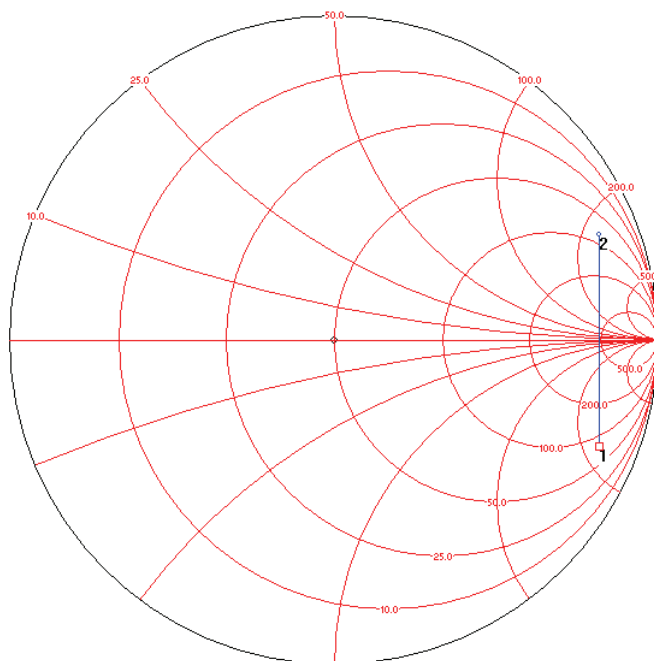

Fig. 9. Z-Smith Chart of the circuit impedance and its corresponding matching conjugated point.

Table 1 shows that the Q -factor for the circuit's impedance - 2,9 - is quite close to the value we want to reach. Anyway, we have designed a suitable matching network and for that reason the capacitors inside this network are so small. Actually, using this matching we can reach Q -factor equal to 3.

Matching Network is used to achieve formula 5 though the use of Smith Chart. According to the theory of RF adaption, a serial capacitor ($C_1=6.6\text{pF}$) plus a parallel capacitor ($C_2=2.8\text{pF}$) are chosen after analyzing some tests based on Smith Chart and considering desired goals.

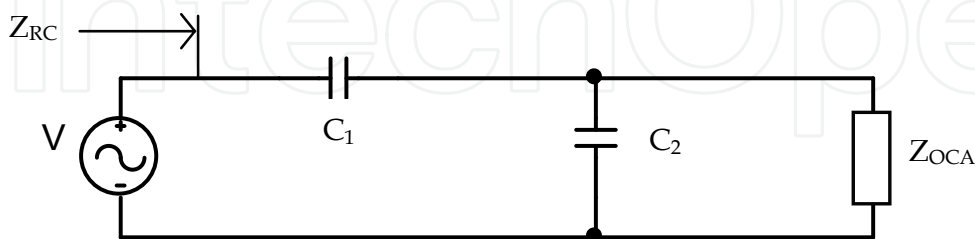

Fig. 10. Final Scheme of the Matching Network.

Impedance	Ω	Q-Factor
Z_{RC}	$80-j232$	2.9
Z_{OCA}	$80+j240$	3.0

Table 2. impedance and Q-factor at 2,45 GHz

In fact, the set of the Integrated Chip, matching network and transformer can be analyzed as a RLC resonant circuit. Then, in chapter 4.1, a study of the whole circuit and its response is going to be performed.

4.1 Resonant circuit RLC parallel process.

The equivalent Circuit model of the Reader plus the entire Tag can be modelled as a parallel resonant circuit LC (Yan et al, 2006). According to coupling volume theory the resonance is required to make good use of the power transferred to the label antenna.

$$f_{\text{resonant}} = \frac{1}{2\pi\sqrt{L \cdot C}} \quad (17)$$

Optimal power transferred to the label antenna is achieved through coil inductance at the carrier frequency resonance ($f_{\text{resonant}}=f_0=2.45$ GHz). The capacitor's chip is about 28pF, which fulfills our goals, also being acceptable compared to other researches (e.g., Sabri et al, 2006). On the other hand, designed capacitance is charged up to 1.5 V level in less than 50 s (Gregori et al, 2004) in order to deliver an output voltage higher than 1.2V to the Chip.

After analyzing whole equivalent impedance, set by lumped elements, on the right side of the Receiver (figure 11), Transformer's equivalent circuit will lead us to study and determine the OCA and reader antennas (figure 12).

$$n = \sqrt{\frac{L_{\text{reader}}}{L_{\text{OCA}}}} \quad (18)$$

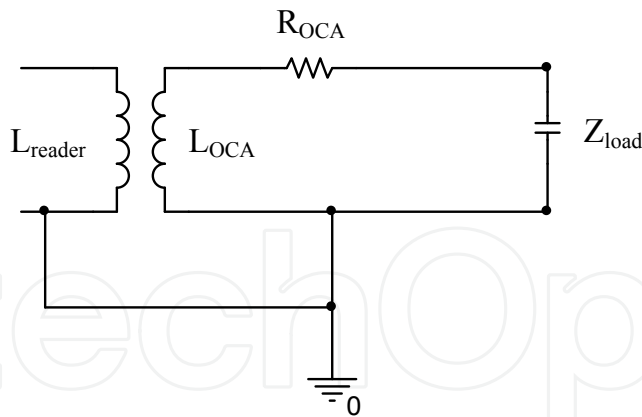

Fig. 11. The Reader, OCA and Tag equivalent scheme.

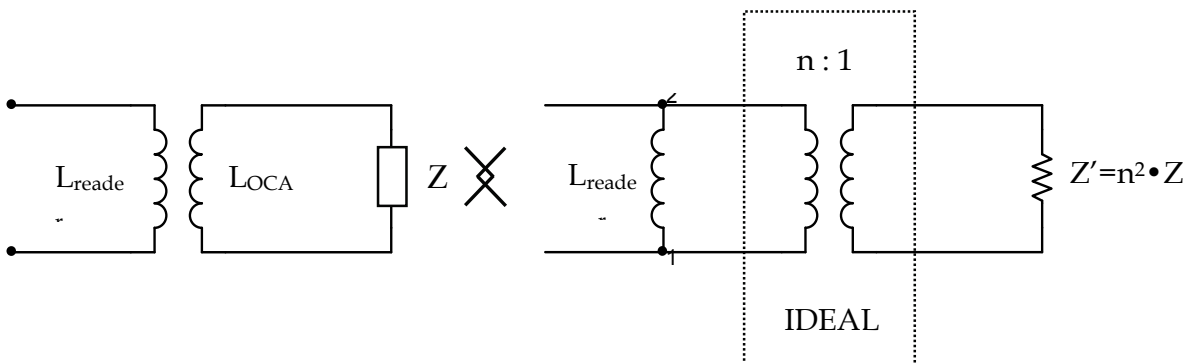

Fig. 12. The equivalent circuit of the transformer.

According to the electrical equivalent scheme of the transformer, both coils inductances can be substituted by the reader antenna introducing a new parameter n , which is the proportional to the reader antenna and inversely proportional to the Tag.

Assuming that Z is composed by R_{OCA} and X_{load} in series, as figure 7 shows. Thus, $Z = R_{OCA} + R_{load} \parallel C_{load} = 160 \Omega \parallel 270 \text{ pF}$.

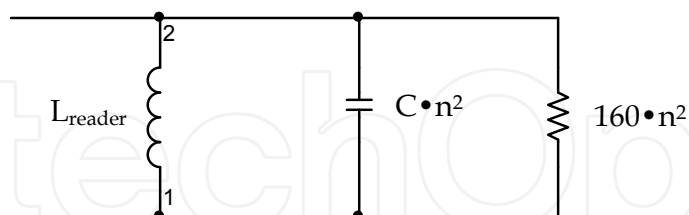

Fig. 13. Equivalent RLC circuit

Resonant RLC circuit provides (figure 13), through formula 18 a relationship between both coils and parameter n , a solution for the reader's coil at resonant frequency of the circuit, f_0 .

$$L_{reader} = \sqrt{\frac{L_{OCA}}{C} \cdot \frac{1}{(2\pi \cdot f_0)^2}} \tag{19}$$

Actually, the final expression for the Reader's inductance depends on the value of the OCA's inductance and the capacitors located at the matching network. Thus, Tag's antenna has been finally designed by $L_{reader} = 15,6 \text{ nH}$ and $n = 1$.

4.2 Lumped element model

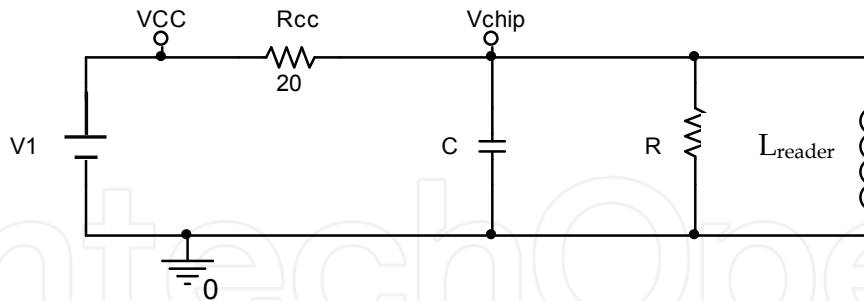

Fig. 14. Final equivalent RLC scheme.

As a result, figure 14 shows the equivalent circuit of the entire Tag, which describe the same behaviour, working at the resonant frequency and delivering enough voltage to feed the Chip (wake-up voltage claimed by producer into datasheet is 1.4V). Therefore, the input signal, after rectifier stage, supplied to the subsequent circuit will be stable for establishing and maintenance a communication between reader and Tag within a near field.

5. Tag antenna geometry

The type of chosen antenna is called a magnetic dipole antenna. Where the radius of the loop and the current (I) which has a Φ orientation and the radiation vector is:

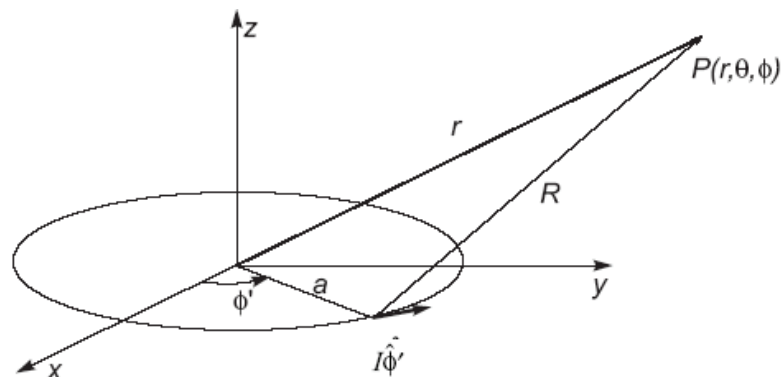

Fig. 15. total Power and Magnetic field radiated by a loop.

$$\vec{N} = \oint_{\langle 2\pi \rangle} I \hat{\phi}' e^{jk\hat{r}} a d\phi' \quad (20)$$

The expressions for the radiation vector in a loop in polar coordinates can be expressed (r, θ, Φ):

$$N_r = a I \sin\theta \int_0^{2\pi} e^{jka \sin\theta \cos(\phi-\phi')} \sin(\phi-\phi') d\phi' \quad (21)$$

$$N_\theta = a I \cos\theta \int_0^{2\pi} e^{jka \sin\theta \cos(\phi-\phi')} \sin(\phi-\phi') d\phi' \quad (22)$$

$$N_\phi = a I \int_0^{2\pi} e^{jka \sin\theta \cos(\phi-\phi')} \cos(\phi-\phi') d\phi' \quad (23)$$

These last expressions is illustration of the Bessel functions. Computing these formulas according to the geometry of antenna, we get this new formulas:

$$N_r = 0 \quad (24)$$

$$N_\theta = 0 \quad (25)$$

$$N_\phi = j2\pi a I J_1(ka \sin\theta) \xrightarrow{\text{when } a \ll \lambda} N_\phi = jk\pi a^2 I \sin\theta \quad (26)$$

The correct proof for a circular loop with the uniform current. The total radiated power is:

$$P_r = \iint K d\Omega = 20\pi^2 (ka)^4 \quad (27)$$

$$\text{and } K = \frac{\eta}{4\lambda^2} |N_\phi|^2 = k^2 \eta \pi a^2 I \frac{e^{-jkr}}{4\pi r} \sin\theta \quad (28)$$

Where η is the impedance wave and k is the wave number.

From the centre of the loop, its near magnetic field radiation falls off with r^{-3} and increases linearly with the number of turns N . Reminding that μ_0 is the permeability of the free space ($\mu_0 = 4\pi \cdot 10^{-7}$).

$$B_z = \frac{\mu_0 I N a^2}{2(a^2 + r^2)^{3/2}} \xrightarrow{r^2 \gg a^2} B_z = \frac{\mu_0 I N a^2}{2r^3} \quad (29)$$

5.1 Structure

OCA schematic structure consists of a copper coil layer (Cu/USG single damascene process loop) with thickness of 1 μm to come up with both optimal Q-factor for the power conversion and match the antenna to the subsequent Chip. OCA was also covered by a 0,5 μm silicon nitride as passivation. Then, a thick dielectric undoped SiO_2 (USG) layer $\sim 19,3 \mu\text{m}$. The coil and Al-shielding layer are interspaced by a SiO_2 dielectric substrate containing deep vias, with a lower thickness of the metal. In order to resume the mutual EM interference between OCA and the tag's circuit an AL-shielding layer is used. It also enhances the Q-factor, reducing its rate. Finally, the silicon substrate is given by closed boundary (ground) to represent the backing plate.

5.2 Design

The optimal goal in terms of size, minimizing OCA in order to suit with the Integrated Chip dimension which is 0,64mm \times 0.64 mm. Modelling is initiated by entering the substrate details of the layers such as shown in figure 16. Details depend upon whether the substrate layer is lossless, lossy, or a conducting layer, it is important to achieve these parameters in the 1 correct manner. For lossless substrates such as silicon dioxide (SiO_2) the relative permittivity ($\epsilon_r = 4.1$) and thickness is entered. For substrates with complex permittivity (and hence lossy) such as silicon (Si), the real part of the permittivity is entered together with a conductivity value in S/m. For metals, parameters are conductivity and thickness (Wilson, 2002). The variations of Q-factor pointed to the thickness of the substrate -19,3 μm

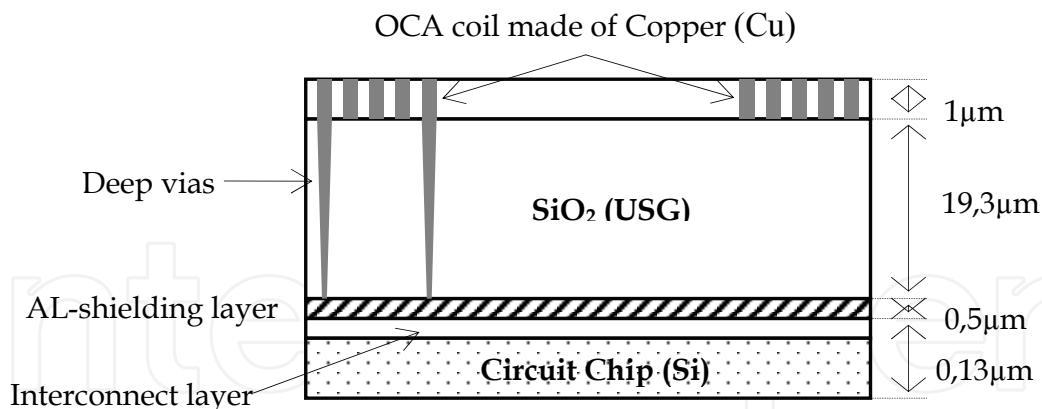

Fig. 16. The schematic cross-section of tag chip with OCA.

thickness of SiO_2 - of OCA's Coil (Guo et al, 2004). Nevertheless, Metal thickness (Cu) is set to $1 \mu\text{m}$ in order to design the steady antenna, when longer copper increases the real part of the impedance.

OCA design is performed through software IE3D; all parameters given previously with advised geometry of the coil. OCA impedance is characterized through reactance and resistance computed from the measured S_{11} parameter at the working frequency ($f_0 = 2.45 \text{ GHz}$), and dimension optimisation is performed in order to reach global goals; both size and load impedance.

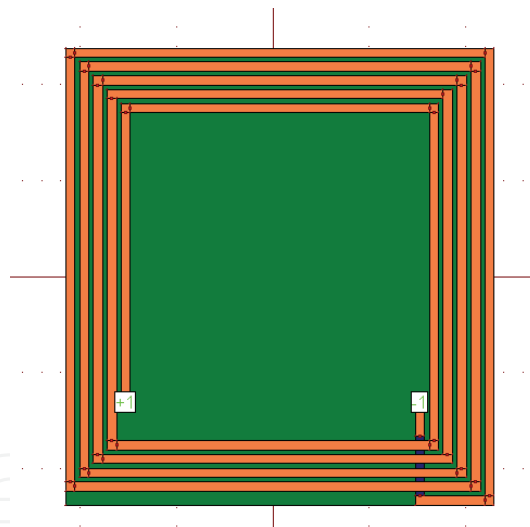

Fig. 17. Initial design.

Going in depth with the main goal, in terms of size, minimizing OCA in order to suit with the Tag dimension which is $0.64\text{mm} \times 0.64 \text{ mm}$. Looking at the pattern, by changing the space of trace width and line spacing, input impedance of the coil becomes modified too. Actually, when playing with the width on the antenna, it means the breadth of the SiO_2 substrate layer, it is possible to modify the real part of the input impedance of the antenna. Final goal keeps on the same state; the challenge is to get 80 and 232Ω as a real and imaginary part respectively. However, it is possible to play with the width (initially set to $12 \mu\text{m}$) of the metals used - copper and aluminium layer - and change also the input impedance. Do not forget about the length of the inductors metallic layer, in this case copper. If it is getting longer, then the real part is increasing. Space line is set to $6 \mu\text{m}$. It is

important to point it out that the ports are located in the exact place as Pad1 and Pad2, in order to get the most optimal-real antenna.

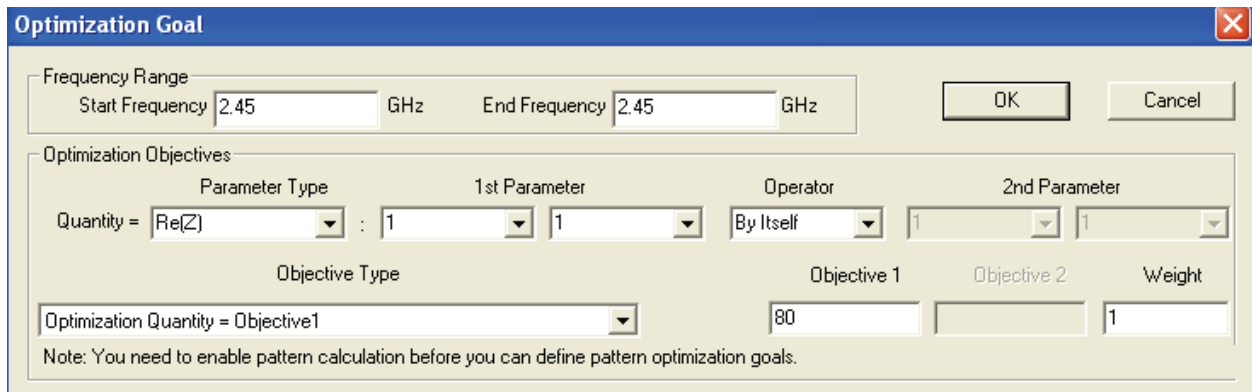

Fig. 18. Optimization goal for the real part of S_{11} at 2.45 GHz. Objective: $\text{Re}[S_{11}] = 80\Omega$.

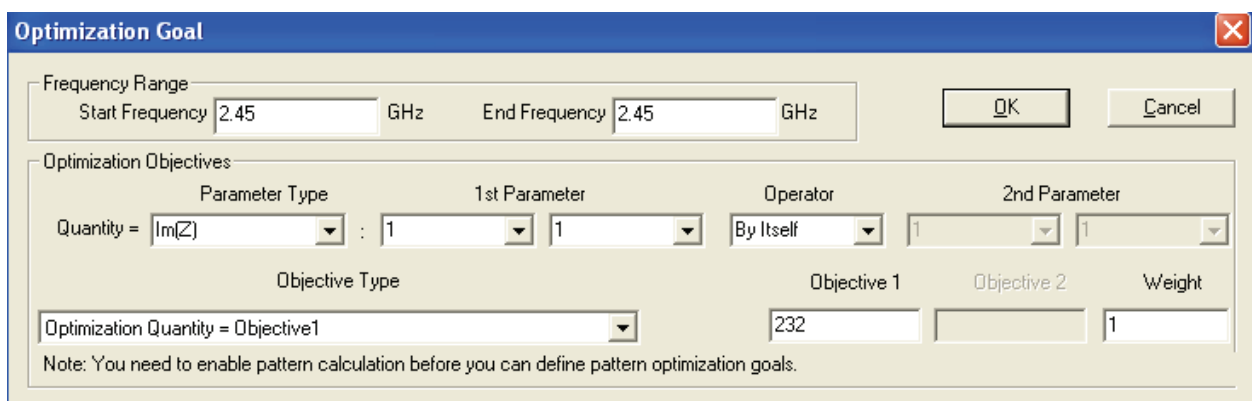

Fig. 19. Optimization goal for the imaginary part of S_{11} at 2.45 GHz. Objective: $\text{Im}[S_{11}] = 232\Omega$.

Indeed, figure 21 shows the final Antenna’s model after optimization process, a rectangular coil; 0.7 mm x 0.75 mm, which is quite close to the optimal one introduced initially. Looking at its properties and behaviour, Figure 22 shows the equivalent input impedance, computed through the S_{11} parameter, which fully accomplish the desired properties.

<input checked="" type="checkbox"/>	#	Z
<input checked="" type="checkbox"/>	3	0.019800
<input checked="" type="checkbox"/>	2	0.000500
<input checked="" type="checkbox"/>	1	0.000000
<input checked="" type="checkbox"/>	A	3D Polygon

Fig. 20. Layers’ depths

6. Conclusion

The process of fabricating the antenna on the top of the RFID chip eliminates the need for a separated and costly expensive process for antenna printing and assemblage, compulsory for a separated “off-chip” antenna which is much more times larger than the chip itself. This

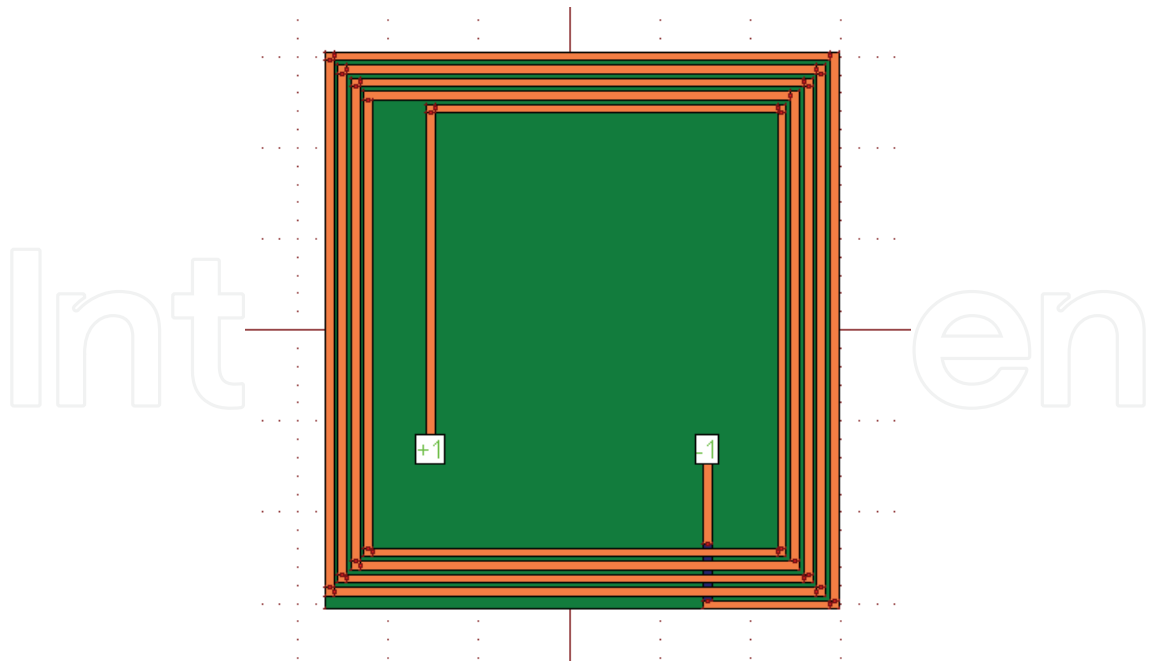
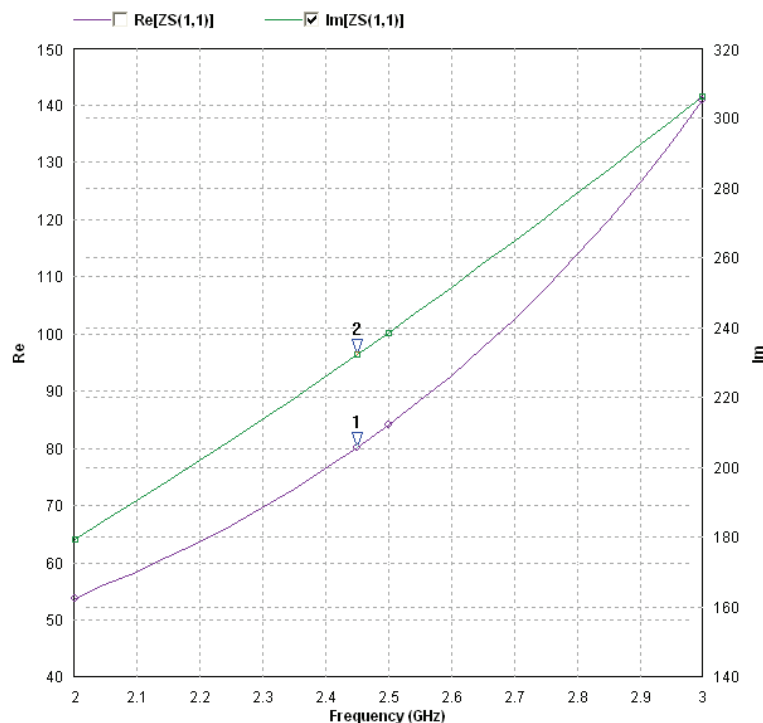

Fig. 21. Optimized design.



#	X	Y
1	2.45	80.1176
2	2.45	232.237

Fig. 22. Final input impedance of the antenna designed.

technology requires a layer of a suitable dielectric to be deposited on the chip surface and isolates the antenna from the circuits below. Overall, conventional RFID tags are typically of a few cm² in size and more expensive as well. In comparison, this newly developed chip

(EM4222) is considerably miniaturized, less than 1 mm² and at a lower cost, which is packed with powerful functions too. Furthermore, designed On-Chip Antenna (OCA) is based on inductive coupling technology resonating at the working frequency selected and embedded into the Chip. The antenna is performed by the coil and it is modelled by lumped elements and it is implemented through 3D EM simulation tool; the software used to perform this design is IE3D.

Design at glance, both the Reader and the Tag coils are drawn together in order to deliver the maximum signal permitted to wake up the Chip. The matching network stage must be designed in order to deliver maximum power from the Tag coil to the Chip. However, the final Antenna designed (0.7 mm x 0.75 mm) is a bigger than the Chip (0.64mm x 0.64 mm), but considered optimal since it is referred to a millimeter scale and its features accomplish main goals in the terms of adaptation. Our results, according to settings and chosen materials, bring into agreement with the title of this chapter, a small OCA antenna operating within the near field.

7. Acknowledgement

This work has been conducted in the Department of Telecommunication Engineering at the Czech Technical University in Prague and supported by the Ministry of Education, Youth, and Sport of the Czech Republic under research program MSM6840770038.

8. References

- Atmel Corporation. (2002). Atmel release document. *Tag Tuning/RFID, application Note*. 2055A-RFID-07/02. San Jose. USA.
- Lauss Finkenzeller. (2003). *RFID Handbook, fundamentals and Applications in Contactless Smart Cards and Identification*. Editorial Wiley, pp 20.
- Stefano Gregori, Yunlei Li, Huijuan Li, Jin Liu, Franco Maloberti,. (2004). ISLPED'04, August 9-11 2.45 GHz Power and Data Transmission for a Low-Power Autonomous Sensors Platform. California. USA.
- L. H. Guo, W. G. Yeoh, Y. B. Choi, X. S. Chen, H. Y. Li, M. Tang, G. Q. Lo, N. Balasubramanian, and D. L. Kwong. (2004). *Design and Manufacturing of Small Area On-Chip-Antenna (OCA) for RFID Tags*. Institute of Microelectronics, 11 Science Park Road, Singapore.
- L. H. Guo, A. P. Popov, H. Y. Li, Y. H. Wang, V. Bliznetsov, G. Q. Lo, N. Balasubramanian, and D.-L. Kwong. (2006). *A Small OCA on a 1×0.5-mm² 2.45-GHz RFID Tag – Design and Integration Based on a CMOS-Compatible Manufacturing Technology*. IEEE electron device letters, vol. 27, no. 2, february 2006.
- Lluis Prat Viñas. (1999). *Circuits and electronics devices. Electronic's theory*. UPC Publishing. pp 169. Barcelona. Spain.
- Sabri Serkan Basat, Dr. Manos M. Tentzeris, Dr. John Papapolymerou, Dr. Joy Laskar. (2006). *Design and characterization of RFID modules in multilayer configurations*. Georgia Institute of Technology, December. Georgia.
- M. Usami. (2004). *An ultra small RFID chip: μ-chip*. Proc. RFIC, 2004, pp. 241-244.. Japan.
- H. Yan, J.G. Marcias Montero, A. Akhnoukh, L.C.N. de Vreede, J.N. Burghartz. (2006). *An Integration for RF Power Harvesting*. DIMES institute of the Delf. University of Technology. Netherlands.
- M P Wilson. (2002). *Modelling of integrated VCO resonators using Momentum*. Tality,UK.

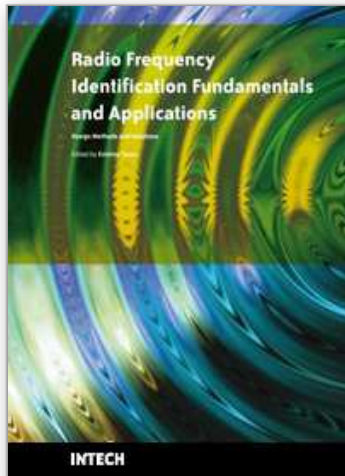

Radio Frequency Identification Fundamentals and Applications Design Methods and Solutions

Edited by Cristina Turcu

ISBN 978-953-7619-72-5

Hard cover, 324 pages

Publisher InTech

Published online 01, February, 2010

Published in print edition February, 2010

This book, entitled Radio Frequency Identification Fundamentals and Applications, Bringing Research to Practice, bridges the gap between theory and practice and brings together a variety of research results and practical solutions in the field of RFID. The book is a rich collection of articles written by people from all over the world: teachers, researchers, engineers, and technical people with strong background in the RFID area. Developed as a source of information on RFID technology, the book addresses a wide audience including designers for RFID systems, researchers, students and anyone who would like to learn about this field. At this point I would like to express my thanks to all scientists who were kind enough to contribute to the success of this project by presenting numerous technical studies and research results. However, we couldn't have published this book without the effort of InTech team. I wish to extend my most sincere gratitude to InTech publishing house for continuing to publish new, interesting and valuable books for all of us.

How to reference

In order to correctly reference this scholarly work, feel free to copy and paste the following:

Alberto Vargas and Lukas Vojtech (2010). Near Field On Chip RFID Antenna Design, Radio Frequency Identification Fundamentals and Applications Design Methods and Solutions, Cristina Turcu (Ed.), ISBN: 978-953-7619-72-5, InTech, Available from: <http://www.intechopen.com/books/radio-frequency-identification-fundamentals-and-applications-design-methods-and-solutions/near-field-on-chip-rfid-antenna-design>

INTECH
open science | open minds

InTech Europe

University Campus STeP Ri
Slavka Krautzeka 83/A
51000 Rijeka, Croatia
Phone: +385 (51) 770 447
Fax: +385 (51) 686 166
www.intechopen.com

InTech China

Unit 405, Office Block, Hotel Equatorial Shanghai
No.65, Yan An Road (West), Shanghai, 200040, China
中国上海市延安西路65号上海国际贵都大饭店办公楼405单元
Phone: +86-21-62489820
Fax: +86-21-62489821

© 2010 The Author(s). Licensee IntechOpen. This chapter is distributed under the terms of the [Creative Commons Attribution-NonCommercial-ShareAlike-3.0 License](#), which permits use, distribution and reproduction for non-commercial purposes, provided the original is properly cited and derivative works building on this content are distributed under the same license.

IntechOpen

IntechOpen