

We are IntechOpen, the world's leading publisher of Open Access books Built by scientists, for scientists

4,800

Open access books available

122,000

International authors and editors

135M

Downloads

Our authors are among the

154

Countries delivered to

TOP 1%

most cited scientists

12.2%

Contributors from top 500 universities



WEB OF SCIENCE™

Selection of our books indexed in the Book Citation Index
in Web of Science™ Core Collection (BKCI)

Interested in publishing with us?
Contact book.department@intechopen.com

Numbers displayed above are based on latest data collected.

For more information visit www.intechopen.com



Measurement and Control of Carrier-Envelope Phase in Femtosecond Ti:sapphire Laser

Zhiyi Wei, Hainian Han, Wei Zhang, Yanying Zhao, Jiangfeng Zhu,
Hao Teng and Qiang Du

*Joint Laboratory of Advanced Measurement Technology, Institute of Physics, Chinese
Academy of Sciences, Beijing 100190.
PR China*

1. Introduction

The emergence of few-cycle laser pulses induced enormous interests on the nonlinear phenomena, such as above-threshold ionization[1~3], high harmonic generation[4, 5] and isolated attosecond generation[6~13] etc. The state-of-the-art few-cycle laser generators, like Kerr-lens mode-locked Ti:sapphire lasers, have delivered directly from oscillator optical pulses with the duration of 5fs [14,15], which corresponds to less than two optical cycles in the near infrared wavelength range. At such short pulse duration, the peak electric field strength of the laser depends strongly on the relative phase between the carrier and the envelope of the pulse. This relative phase is the carrier-envelope phase (CEP). The CEP occurs in the ultrashort pulses, for longer pulses, in general it is not ignored because of the neglectable role. However, the CEP will become significant on the laser matter interaction for few-cycle pulses. It is obvious that the CEP plays an important role in physical processes stated above, especially in attosecond generation schemes, such as interaction between the inert gases and the few-cycle intense pulses [6, 7]and Fourier coherent synthesis among ultrashort lasers with different wavelength[16,17], controlling the CEP is always an important prerequisite.

In fact, the CEP from pulse to pulse in a pulse train that emitted by a mode-locked femtosecond laser is different because of dispersion. The group and phase velocity will differ and cause CEP evolve rapidly when propagating through materials inside the cavity, such as Ti:sapphire crystal, coating mirrors and prisms etc. The pulse-to-pulse CEP change is the carrier-envelope phase offset (CEO). Up to now, several methods have been developed to measure and control the CEO of femtosecond laser pulses train in the frequency domain[18~26]. In this chapter, we will introduce two schemes for measuring the CEO frequency of pulses in femtosecond Ti:sapphire laser. The first and the most widely used technique is the self-reference method, also be termed the f -to- $2f$ method [19~21]. It is to measure the interference beat frequency between the high frequency and the frequency-doubled low frequency spectral components of an octave spanning spectrum. Normally, a photonic crystal fiber (PCF)[27~31] is used to broaden the laser spectrum to octave-spanning bandwidth in such f -to- $2f$ CEO frequency measurement scheme. Although the PCF has advantage of high nonlinear coefficient be easy to generate supercontinuum spectrum by

Source: *Advances in Solid-State Lasers: Development and Applications*, Book edited by: Mikhail Grishin,
ISBN 978-953-7619-80-0, pp. 630, February 2010, INTECH, Croatia, downloaded from SCIYO.COM

self phase modulation (SPM) and four-wave mixing frequency effect, the small core diameter (1~2 μm) and high loss (>70%) may cause significant spectrum fluctuation in case of tiny perturbation, and also limit the usable maximum output power. Then we adopted a novel measurement technique based on difference frequency generation (DFG) in a nonlinear crystal,[22~26], which is also named as Monolithic Scheme. Through the interference beat between the fundamental and the DFG spectral components in the overlapped infrared spectrum region, the CEO frequency signal with high signal-to-noise ratio can be achieved, and at the same time the DFG laser in the mid-infrared spectrum region can also be generated. It is worth mentioned that the CEO of the DFG pulses generated in the mid-infrared is zero, in other words, is self-stabilized, which is valuable in attosecond generation. After stabilized by the servo-electronics phase-locked loop, the CEO frequency of laser pulses in Ti:sapphire lasers based on two schemes showed the similar high stability in short terms, but in the long term characteristics, the latter had obvious advantages than the former in hold time and coherence[32~35]. The measurement schemes and control results of CEO frequency of pulses in Ti:sapphire oscillator will be described in detail in the third and fourth segment.

In chirped pulse amplification (CPA) system, although the CEO frequency of seed pulses emitted from femtosecond oscillator stabilized highly, the CEO of amplified laser pulses can change through the amplified crystal, dispersion material and air[36~38]. Lastly we described the measurement and control the CEO frequency of few-cycle high energy laser pulses at 1kHz repetition rate.

2. Carrier-envelope phase offset in femtosecond laser pulse

As already stated above, the CEP is the relative phase between carrier and envelope peak for a single laser pulse and the CEO is the CEP change from pulse to pulse for a pulses train. If we write the electric field of the laser pulse as

$$E(t) = A(t)\cos(\omega_c t + \varphi) \quad (2.1)$$

then φ determines the CEP, often used to be referred "absolute" phase. The CEO is designated as $\Delta\varphi$. This terminology "absolute" is helpful for distinguish between φ and $\Delta\varphi$ and to emphasize the fact that φ is not relative to a second reference beam. In practice, the methods on measurement and control of φ and $\Delta\varphi$ are different completely. In our experiments, we focused on the measurement and control of $\Delta\varphi$ in the frequency domain.

To understand deeply φ and $\Delta\varphi$, the time and frequency domain descriptions will be helpful. In the time domain, the pulses train emitted from the mode-locked femtosecond lasers delivers the same time interval τ , while in the frequency domain, the spectrum can easily be obtained by a Fourier series expansion, yielding a comb of regularly spaced frequencies, where the comb spacing is inversely proportional to time interval between the adjacent pulses. The corresponding relationship of the pulse train in the time domain and the frequency domain is shown in Fig1 (a) and (b). If $\Delta\varphi$ is zero, the frequency comb distribution of the pulse train from mode-locked Ti:sapphire oscillator is plotted by the dashed lines in Fig.1(b), and if $\Delta\varphi$ isn't zero, there occurs an frequency offset of the whole comb caused by $\Delta\varphi$, defined as f_0 .

The CEO in the pulse train emitted by a mode-locked laser occurs because the phase and group velocities inside the cavity are different. Due to dispersion, the successive pulses

(a) Time Domain

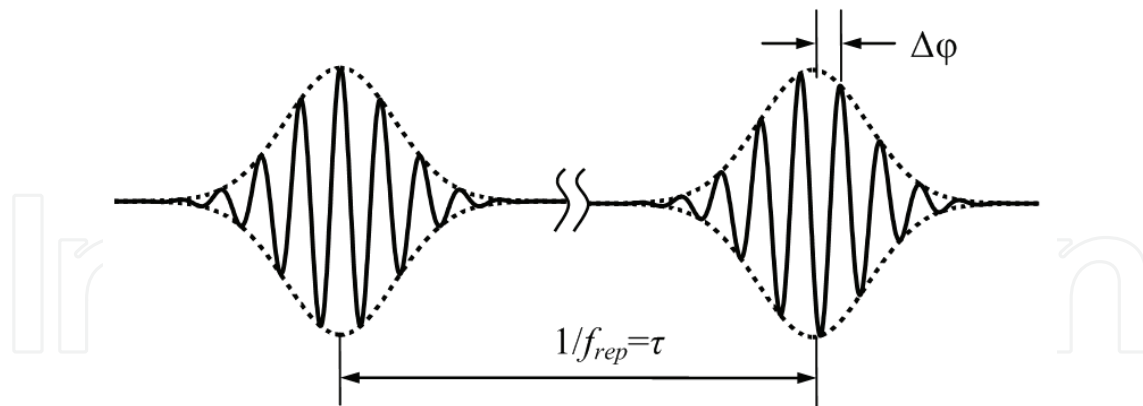

(b) Frequency Domain

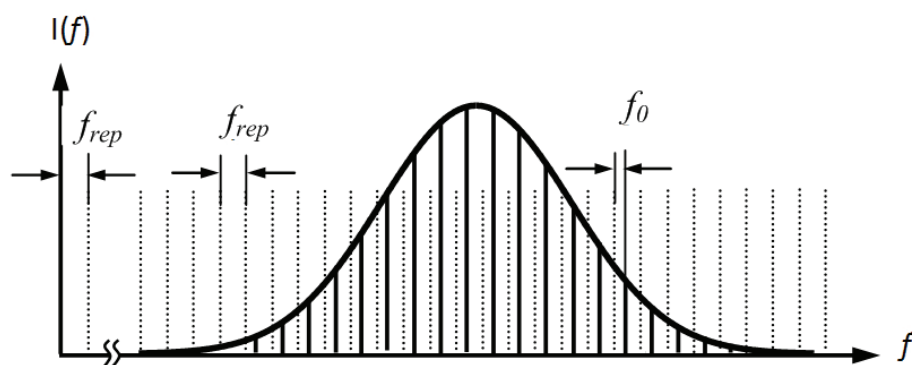

Fig. 1. Pictures of the time-frequency correspondence for a pulse train

output after once per round trip in the cavity will produce the offset phase, it can be expressed as

$$\Delta\phi = 2\pi\omega_c \cdot l \cdot (1/v_g - 1/v_p) \quad (2.2)$$

Where v_p (v_g) is the mean phase (group) velocity in the laser cavity, l is the length of the laser cavity, and ω_c is the carrier frequency.

In the frequency domain, the optical frequencies of the comb lines can be written as:

$$f_m = mf_{rep} + f_0 \quad (2.3)$$

Where m stands for a large integer of order millions that indexes the comb line, f_{rep} is the repetition rate at less than 1GHz in general, and f_0 is the comb offset due to $\Delta\phi$. The f_0 has the relationships with $\Delta\phi$

$$f_0 = \frac{1}{2\pi} f_{rep} \Delta\phi \quad (2.4)$$

Thus, the task of stabilizing $\Delta\phi$ is switched to stabilization of f_0 .

From Eq. (2.3), we can find that the optical frequency f_m is connected directly to the repetition rate f_{rep} and the CEO frequency f_0 . That means a comb system has two degrees of freedom, f_{rep} and f_0 , and both need to be controlled for implement a stable frequency comb.

3. Schemes for measuring the CEO frequency

Controlling the CEO is an important prerequisite for many high intensity laser phenomena that are sensitive to the electric field. To control it, we have to measure it firstly. It is easy to measure the repetition rate with a photo diode detector, however, measurement of the CEO is a much more difficult task. From Eqn. (2.4), we see that the pulse-to-pulse phase evolution causes a rigid shift of the frequency comb by f_0 . Thus, if we can measure f_0 , we can determine the CEO. This gives us an idea that it is possible to measure f_0 with frequency heterodyne coherent techniques. In this segment, we will compare two different frequency measurement schemes for two different home-built mode-locked Ti:sapphire oscillators, that is, f -to- $2f$ technique and 0 -to- f technique.

3.1 f-to-2f interferometer method

To measure the CEO frequency with f -to- $2f$ technique, it is necessary to broaden the spectrum wider than one octave. However, the spectrum bandwidth generated from an ordinary mode-locked Ti:sapphire oscillator is generally less than 100nm. To produce an octave spanning spectrum, the photonic crystal fiber (PCF), an ideal material with high effective nonlinearity is used to extend the spectrum by self-phase-modulated the femtosecond laser pulse generated from ordinary Ti:sapphire oscillators.

If the spectrum is sufficiently broad, for example covering an octave, the low frequency component of the spectrum can be written as

$$f_n = nf_{rep} + f_0 \quad (3.1)$$

and the high frequency component of the spectrum is given by

$$f_{2n} = 2nf_{rep} + f_0 \quad (3.2)$$

There occurs spectrum region where high frequency components and the frequency-doubled of the low frequency components overlapped. Measuring the heterodyne beat signal between the f_{2n} and $2f_n$ in the overlapped spectrum, the offset frequency f_0 can be obtained:

$$2f_n - f_{2n} = 2(nf_{rep} + f_0) - (2nf_{rep} + f_0) = f_0 \quad (3.3)$$

Since the high frequency components and the frequency-doubled of low frequency components are from the same spectrum, the f-to-2f measurement technique also is termed "self-referencing". It should be noticed that the octave-spanning spectrum can be produced by the PCF used outside the cavity of the narrow-bandwidth femtosecond Ti:sapphire oscillator stated above, and also can be yielded directly by the ultrabroad-bandwidth femtosecond Ti:sapphire oscillator developed successfully in recent years[39,40].

The typical experimental setup implementing the f-to-2f interferometer is shown in Fig.2. In reality, a group of comb lines contribute phase coherently to the photodiode signal, so even with at most 10 nanoWatts per comb line (a typical amount for a 100MHz spaced comb after broadening in microstructure fiber) there is enough signal to noise (S/N) to properly lock f_0 . In our experience the achieved S/N is higher than 30 dB enough for reliable phase lock. Except for implementing such typical apparatus for measuring f_0 , there is another f-to-2f interferometer with slight modification in the configuration used in our previous experiments[21]. In our opinion, this new f-to-2f interferometer has some advantages in the

structure and operation, let's introduce it curtly. Fig. 3 shows the modified f-to-2f interferometer configuration. The biggest difference from the standard one is in the position of the PCF and the frequency-doubled crystal. Just this subtle position exchange not only reduces the optical components such as two lens for focusing on LBO crystal, but also relaxes the need of spectrum broaden by PCF, it will be enough to extend the spectrum to 400nm in short wavelength. And the S/N of CEO frequency by this interferometer is higher than 30 dB, satisfy a tight lock.

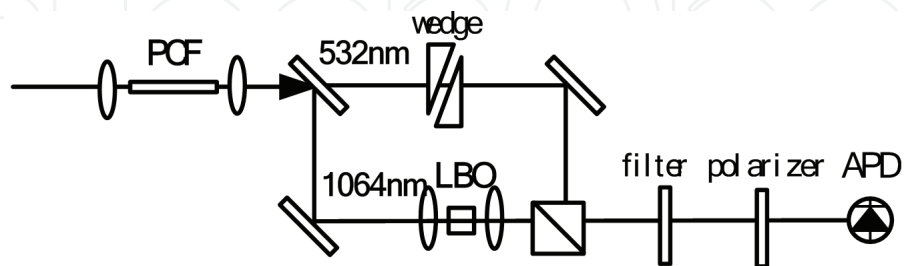

Fig. 2. The standard f-to-2f interferometer configuration

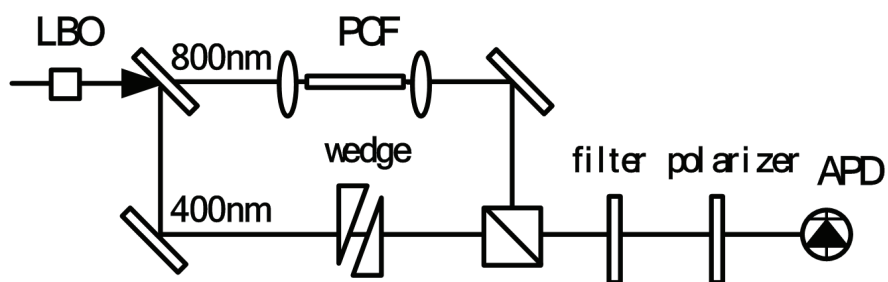

Fig. 3. The configuration of f-to-2f interferometer with modification

3.2 0-to-f method based on difference frequency generation

Although the f-to-2f measurement technique is widely used to measure the CEO frequency of ultrashort pulses emitted from mode-locked Ti:sapphire laser, there have been some disadvantages in the stabilized frequency comb system based on f-to-2f scheme because of its complicated configuration and alignment-sensitive PCF. To generate strong nonlinear effects when ultrashort pulses propagating through it, the core diameter of the PCF has to be made very small, generally at $1\mu\text{m}\sim 2\mu\text{m}$. However, such small core diameter may cause high loss, significant spectrum change in tiny disturb and limit the maximum comb output power. Moreover, excessive dispersion and phase noise of the nonlinear interferometer prevents the broadband spectrum laser from being compressed to few-cycle pulses with low time-jitter. Recently, a novel CEO frequency measurement technique based on the nonlinear difference frequency generation (DFG) and self-phase modulation (SPM) of the few-cycle pulses focused in the monolithic highly nonlinear periodically poled magnesium-oxide-doped lithium niobate (PP-MgO:LN) crystal or other nonlinear crystals is provided [25]. In regions of spectral overlap, a CEO beat frequency between the fundamental wave extended by SPM and the DF wave was observed. This method is termed 0-to-f measurement technique. The schematic of 0-to-f technique by use of DFG is shown in Fig. 4. The DF frequency comb (red line) is produced by mixing of the high frequency part and the low frequency part of the spectrum (blue line), given by

$$f_{DF} = (n_h f_{rep} + f_0) - (n_l f_{rep} + f_0) = (n_h - n_l) f_{rep} \quad (3.4)$$

It is independent of f_0 , means that the CEO of the DF pulse train is zero and the CEP of every pulse is the same. This is the unique characteristics of 0-to-f technique, which is important for precision frequency metrology and attosecond generation.

If the spectrum of fundamental wave broad enough by SPM, it will overlap with the DF frequency comb, where interference beat signal can be obtained at f_0 by 0-to-f comparison.

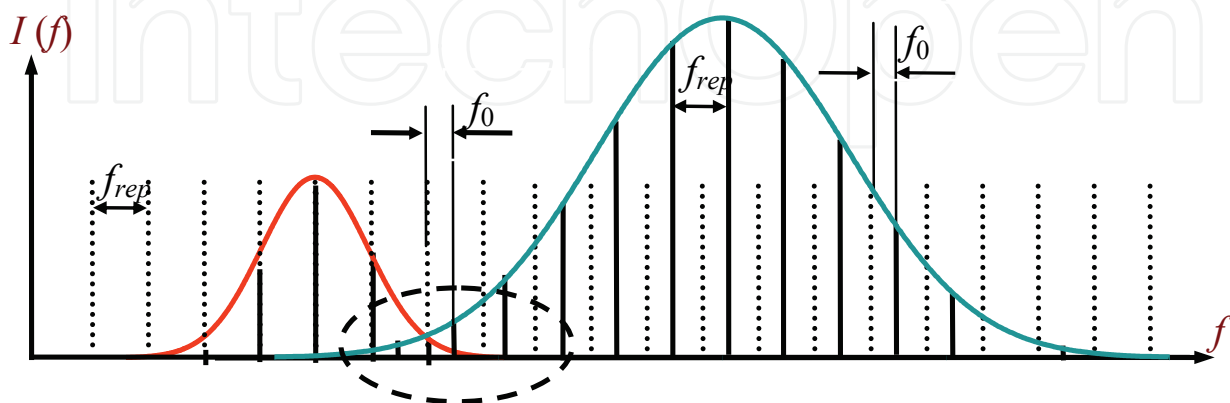

Fig. 4. Schematic of 0-to-f technique for measuring the CEO

The 0-to-f measurement technique is usually implemented in the laser pulse shorter than 10fs with the ultrabroadband spectrum even less than one octave. Such mode-locked Ti:sapphire lasers are available based on the chirped-mirror dispersion compensation technique[41~43]. In our experiment[44,45], the typical laser cavity consists of a pair of concave chirped-mirror, a plane chirped-mirror and an output coupler. The schematic is shown in Fig. 5. The high doped Ti:sapphire crystal (Ti:Sa) was cut at Brewsterd angle with length in 2mm, CM1, CM4 and CM5 are chirped mirrors with high reflectivity from 580 to 1100nm, CM2 and CM3 is a chirped pair mirror with ROC of 50mm, OC is the output coupler. All these mirrors were optimized choiced based on the calculation for dispersion balance among all optics intracavity. Once the mode-locking was started, ultrabroaden

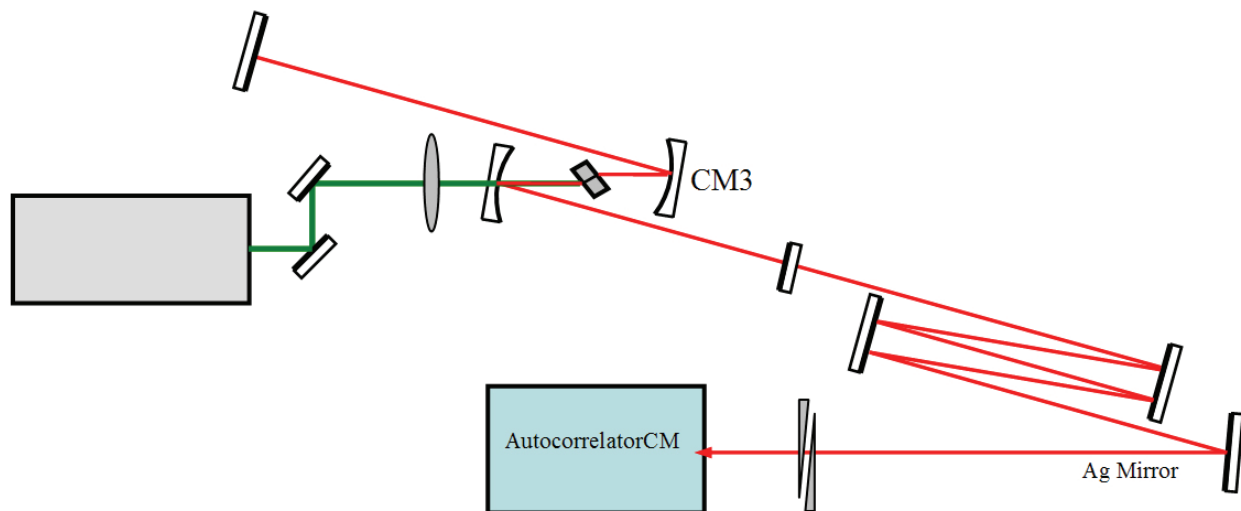

Fig. 5. The mode-locked Ti:sapphire oscillator based on the chirped-mirror dispersion compensation

spectrum can be obtained through the optimized alignment the distance between CM2 and CM3. With the optimized dispersion compensation extracavity with CM 4, CM5 and a pair of silica wedge, we got the interferometer resolved autocorrelation trace as figure 6(A) by using a commercial autocorelator (Femtolasers Inc). It infers the pulse duration is shorter as 7.5fs.

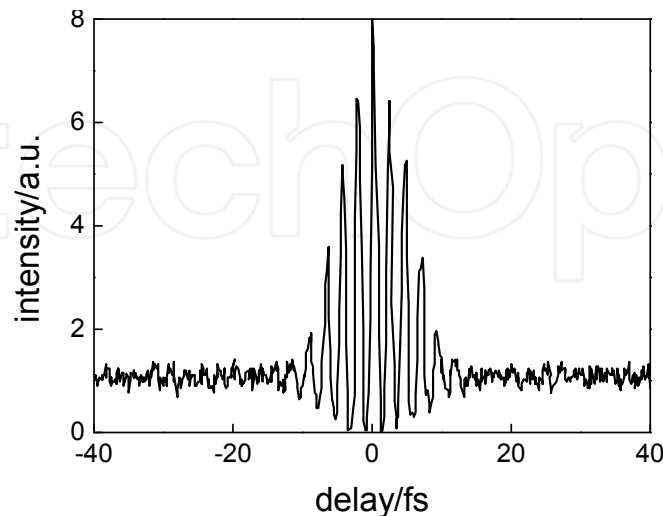

Fig. 6. A. The interferometer resolved autocorrelation trace

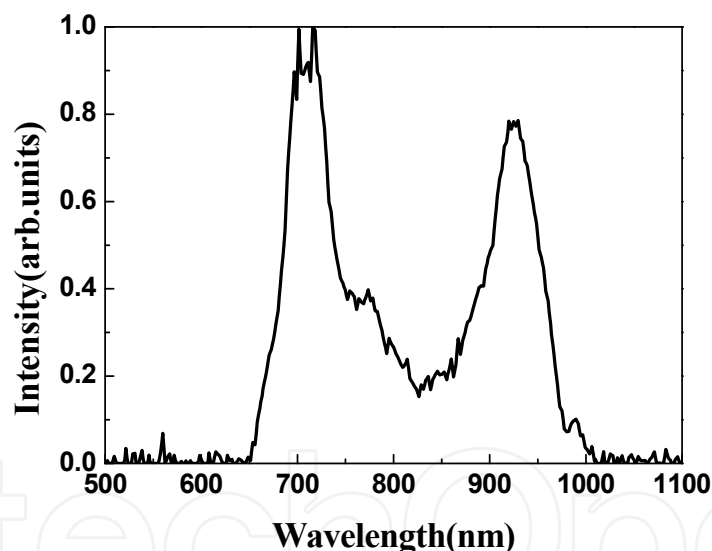

Fig. 6. B Output spectrum of Ti:sapphire oscillator

In 0-to-f measurement technique, the difference frequency is generated between the frequency components in two sides of spectrum, the middle parts of spectrum has little contribution. To generate DFG effectively, we designed and used a special output coupler in the Ti:sapphire laser to enhance the laser intensity in both edges than the central spectrum. With this idea, we generated the artificial spectrum with U-shaped distribution, as Fig.6(B). Two peaks appear around the wavelength of 710nm and 940nm. Such spectrum can greatly optimize the signal-to-noise ratio because of the efficient DFG between two wavelengths at spectrum edges.

Fig. 7. shows the schematic of measuring the CEO frequency of 7.5 fs laser pulses emitted from the Ti: sapphire oscillator by the 0-to-f technique[26]. The few-cycle pulses are reflected

firstly several rounds by two chirped-mirrors outside the cavity to compensate the dispersion caused by the output coupler, and then through a pair of wedges to adjust carefully the residual dispersion. This is a key step for generating the high S/N beat signal. Because both the high and low frequency components for DFG come from the same laser beam, if the dispersion is compensated incompletely, they will not completely overlap in the spatial and temporal domains, which will lead to unable to generate difference frequency.

There is a unique advantage by use of 0-to-f technique to measure the CEO frequency. Except for the high S/N CEO beat signal in the infrared near the fundamental spectrum, the generation of difference frequency with self-stabilized phase happens in the far infrared from the fundamental spectrum at the same time. The difference frequency spectrum is shown in Fig.8[46]. The power of such self-stabilization laser pulses is too low to be measured, however, once through amplification, it will be an ideal light source for some high field applications.

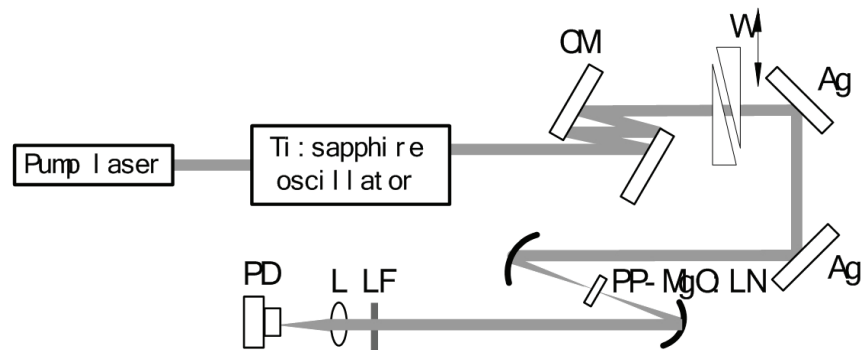

Fig. 7. The Schematic of 0-to-f measurement technique

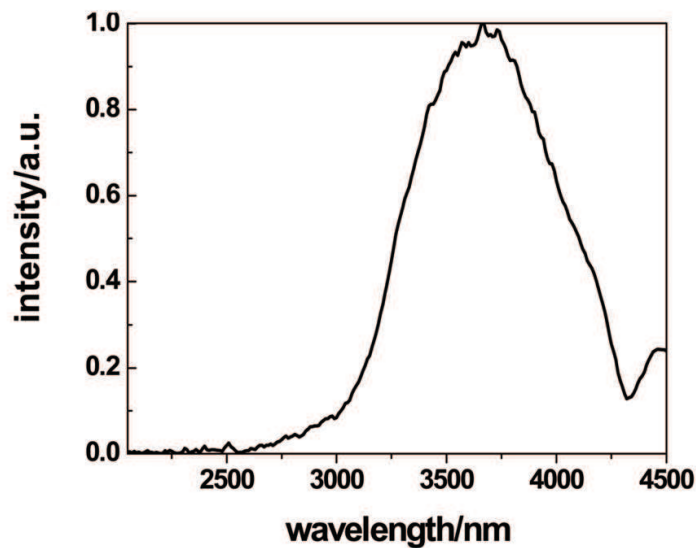

Fig. 8. The spectrum of the DFG with the zero CEO frequency

Comparing with f-to-2f and 0-to-f methods, the latter has obvious advantages, such as higher power, better stability, and no excessive amplitude to phase conversion noise in PCF etc. Additionally, self-stabilization of CE phase by use of DFG, which provides an intrinsically phase-stabilized laser pulses in mid-infrared spectrum, is useful and valuable in the application of the attosecond generation.

4. Robust stabilization of the CEO frequency

The CEO frequency in few-cycle pulses is sensitive to the surrounding environment, such as air flow, temperature shift and even sound noise[47~49]. In practice, anything that can passively reduce the environmental perturbations to the laser relieves the burden placed on servo-loops and leads to a more successful stabilization. From our experiences of stabilizing the CEO frequency in Ti:sapphire laser, cavity design based on the chirped-mirror dispersion compensation is more stable than that based on the prisms dispersion compensation. This is because of beam pointing fluctuations via the prism sequence, which lead to CEP fluctuation, however, CM-based cavities without prisms are free of such fluctuations. In order to realize long term reliable phase lock, some of actions that isolated cavities from the surrounding disturbance include enclosing the cavity in a sealed aluminum box, employing high quality, solid mounts, and using the lowest practical beam height. In addition, it is necessary to use a single frequency, diode-pumped solid state 532nm laser as the pump source, such as Verdi serials made by coherent company, which is helpful to reduce the noise of Ti:sapphire laser.

4.1 Control the repetition rate and the CEO frequency

The repetition rate and the CEO frequency are the two degrees of freedom for few-cycle laser pulses. To stabilize laser frequency corresponds to stabilize these two parameters. In general, the repetition rate and the CEO frequency are locked to the same stable microwave source outside at the same time, such as Rb, Cs or H clocks. Then the stability of the microwave clocks can be transmitted precisely to the optical frequency.

The measurement and control of the repetition rate is relatively easy because of its natural stability, usually shift at Hz level rather than KHz level shift of the CEO frequency. However it is not easy to stabilize with high accuracy. Through glue a mirror to a PZT in the cavity as the controller, then receive the residual transmission light after one mirror by an APD and switch to the electrical signal of the repetition rate, compare with the standard frequency of microwave source and get the control signal after proportional-integral (PI) process to feedback control the PZT, finally the stable cavity length can be realized with experience the long term temperature shift.

Comparatively speaking, control of the CEO frequency is a hard task because it changes fast at KHz level. In this case the responding velocity of PZT is usually unable to follow it, the AOM with high responding velocity used to control the CEO frequency. The AOM can changes lightly the power of the pump laser and lead to the change of the CEO frequency. So in the CEO control feedback loop, the AOM plays the role of controller. In addition, to close the loop, there must be a laser parameter that changes of CEO frequency inside the cavity by hand. A pair of wedges is inserted into the beam path of the cavity to help realization of close loop.

4.2 Stabilization of frequency comb based on DFG

It is well known, under the condition of the same laser average power, each mode power of the comb linearly increases with the repetition rate. Therefore, frequency comb with high repetition rate is more helpful for optical frequency measurements. A mode-locked Ti:sapphire laser with 350MHz repetition rate based on chirped mirrors dispersion compensation technique is developed[35]. Fig.9 is the schematic layout of the stabilized frequency comb system. Chirped-mirror mode-locked Ti:sapphire oscillator consists of five

mirrors, of which mirror M4 with the diameter of 6mm, thickness of 2.3mm is glued to a PZT used to control the length of the cavity. A pair of wedges is put between the mirror M3 and M4 to adjust crudely the CEO frequency for loop close. After dispersion pre-compensating outside the cavity by a pair of chirped mirrors, the output laser with average power of 300mW and pulse duration of 7 fs is focused on a 2mm-thick MgO:PPLN crystal in the in-loop 0-to-f unit for measurement of the CEO frequency. And the excess second 0-to-f measurement unit, called out-of-loop, have built for analyzing and comparing the phase noise of the CEO frequency. Figure 9 also shows the electrical feedback system for f_0 and f_{rep} locking. The signal analyzer, three microwave frequency synthesizers and two frequency counters are all referenced to a 10MHz standard signal derived from a local TV-Rb clock.

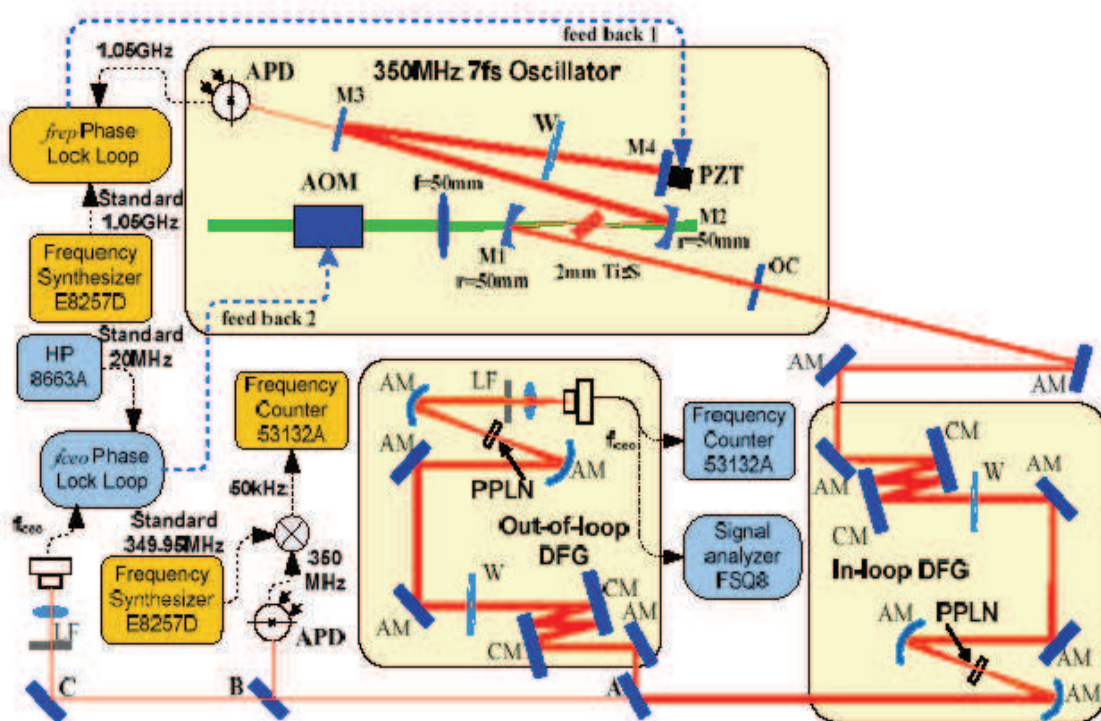

Fig. 9. Setup for stabilizing few-cycle pulses in Ti:sapphire laser

The repetition rate of the femtosecond laser is phase locked to a standard 1.05GHz signal from a frequency synthesizer and stabilized by controlling the cavity length. In the phase locked loop for the stabilization of f_{rep} , the 3rd harmonic of f_{rep} is extracted and mixed with a standard output signal of 1.05GHz from the synthesizer. The phase error signal is filtered by PI processor and fed back to the Ti:sapphire laser oscillator by a PZT mounted on the end mirror M4 to stabilize the cavity length. The locking result of f_{rep} is shown in Fig 10. The continuous locking time is 32673s (Gate time 1s), and the standard deviation is 220 μ Hz, the Allan deviation of locked f_{rep} , starting from 6×10^{-14} (1-s averaging time) and depending on close to τ^{-1} (red line).

Compared with the f-to-2f scheme based on a piece of PCF for octave-spanning spectrum generation and an interferometer for f_0 detection, the monolithic scheme without PCF can make great and outstanding contribution to the long-term stabilization. In the case of no additional servos applied except for two set of phase-locked loop for locking f_0 and f_{rep} simultaneously, the continuous locking time can be exceeded to 32673s (gate time 1-s), i.e.,

more than 9 hours, which is about twenty-fold longer compared to the locking result of f-to-2f scheme we have reported. The locked result of f_0 over the whole period is shown in Fig. 11 and the standard deviation is about 2.6 mHz. The Allan deviation starts from 2×10^{-11} (1-s gate time) and drops close to τ^{-1} (red line in Fig. 9), which is expected for the phase-locked signal.

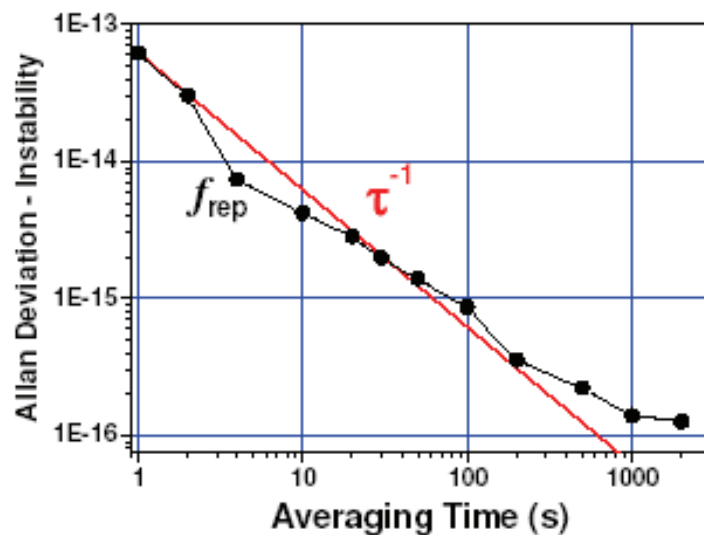

Fig. 10. Allan deviation of f_{rep} at different averaging time

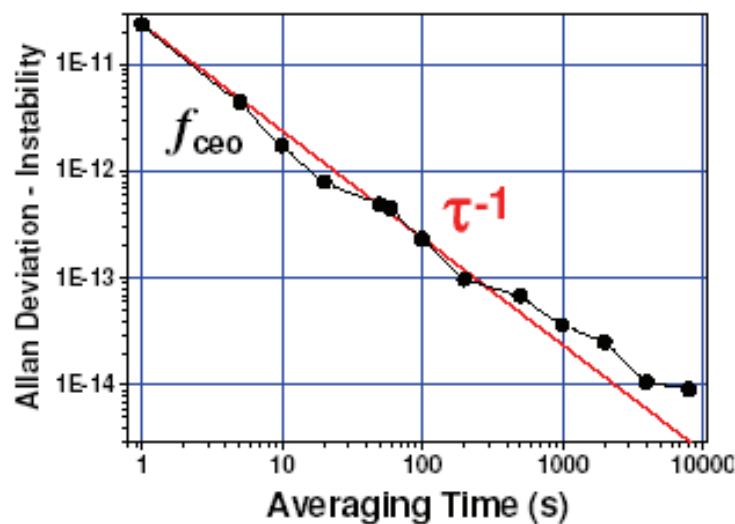

Fig. 11. Allan deviation of f_0 at different averaging time

4.3 In-loop and Out-of-loop phase noise measurement

Long term phase coherence of the CEP became the key parameter for the utility of CEP-stable pulses in many actual nonlinear experiments after control of a pulse train's CEO. As seen from eqn. (2.4), slight offset from $f_0 = 0$ cause an accumulated phase noise in $\Delta\varphi$. Thus the phase noise of $\Delta\varphi$ is displayed by the frequency noise of f_0 and leads to broadening of the linewidth in f_0 . In order to investigate the accumulated phase noise of CEP in the above frequency comb based on 0-to-f scheme and compare the noise induced by PCF and PPLN crystal, two same 0-to-f apparatus are built simultaneously, each with its own monolithic PPLN crystal. As shown in Fig. 9, the laser beam is separated into two parts by a half-to-half

beam splitter (mirror A). One is focused onto the first MgO:PPLN crystal for f_0 control, the other part is focused onto the second MgO:PPLN crystal for an independent out-of-loop phase noise measurement. Though the SNR of f_0 for each part is about 35dB (100kHz resolution bandwidth), which is lower because the input power of each beam decreases to only one half than before, it is still sufficient for control and phase noise measurement. The in- and out-of-loop single-side-band (SSB) phase-noise power spectral densities (PSD) of f_0 are obtained by injecting these signals into a signal analyzer. The measured SSB phase-noise PSD of f_0 and the noise floor of analyzer are shown in Fig. 12, respectively. The phase error integrated from 1Hz to 100kHz is about 230mrad for in-loop and 242 mrad for out-of-loop. There is a typical 12 mrad increase from in-loop accumulated phase noise to out-of-loop. On the contrary, in the conventional f-to-2f scheme, where a piece of PCF is used for octave-spanning spectrum generation, the phase noise for out-of-loop is usually increased by several times compared with that for in-loop. As reported in Ref. [50], the accumulated phase noise is 0.1 rad for in-loop and more than 0.2 rad for out-of-loop [1Hz, 100kHz], corresponding to an approximate two-fold increase. This significant difference originates from the conversion of amplitude fluctuations to phase fluctuations in PCF. Based on the monolithic scheme, however, there is no additional noise introduced by PCF, and then the difference between in- and out-of-loop is steeply decreased.

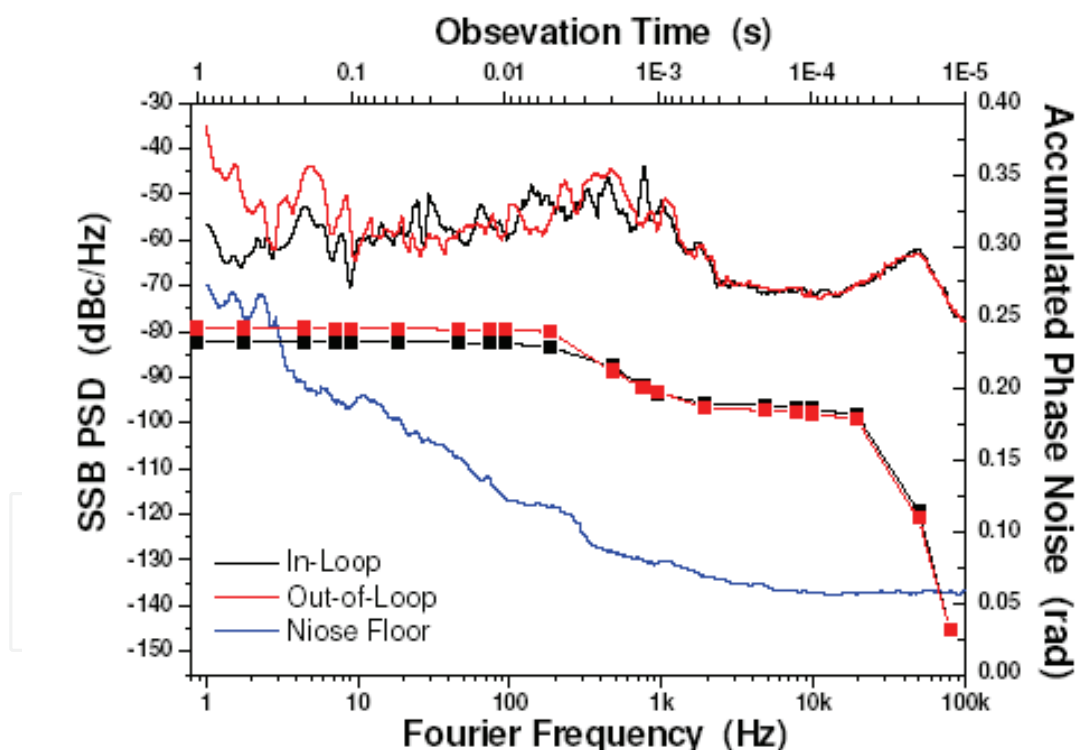

Fig. 12. Bottom-Left: the SSB noise power spectrum of f_0 as the function of Fourier frequency. Black line: in-loop phase error. Red line: out-of-loop phase error. Blue line: the noise floor of the signal analyzer. Top-Right: the accumulated phase noise of in-loop (black closed square) and out-of-loop (red closed square) as the function of observation time.

Here it should be specifically noted that the coherence of f_0 is not a coherence of optical carrier wave with successive pulses, just is the coherence of CEP. In the in-loop and out-of-loop phase measurement, the repetition rate is not locked, so the optical carrier frequency

varies with f_{rep} in the case of stable f_0 . If f_{rep} is stabilized then optical coherence in pulses train can be realized. Measuring the phase noise of f_0 without locking f_{rep} doesn't affect the coherence result of CEP here. However, considering that the optical frequency has a large multiplication factor of 10^6 at repetition rate, simply locking f_{rep} to a stable microwave clock will be not adequate for realization of the long term coherence of optical frequency. There have been interests of locking f_{rep} to an optical clocks or ultrastable optical cavity, which will most likely be necessary to get much higher stability and longer coherent time.

5. Control the CEP of high energy laser pulse at 1kHz repetition rate

CEP control of the few cycle light pulses enables the generation of optical waveforms with the reproducible electric field profile which has shown its importance in the observed phenomena, such as above-threshold ionization and high-order harmonic generation (HHG). In particular, isolated attosecond pulse generation through HHG is strongly affected by the drift of CEP. Additional CEP drift is occurred in the amplification stage even if the CEP of the seed oscillator is fixed. Several factors including thermal fluctuation of the environment, beam pointing fluctuation and the laser pulse energy fluctuation may result in the drift and fluctuation to the CEP of the amplified pulses. Typically the amplification is operated at a low repetition rate with large pulse energy. To evaluate and further control the CEP slip of the amplified pulses, a single-shot measurement of the spectral interference (SI) is proposed[36,37].

Phase locking is achieved by modulating the pump power of the seed oscillator through the AOM which varies the transmitted power proportional to the phase error signal generated by the phase locking electronics. As a result, for Ti:sapphire CPA system at 1kHz repetition rate seeded by few-cycle pulses at 80MHz repetition rate, given selecting $f_0=20\text{MHz}$ and being locked to quarter of f_{rep} , every 4th pulse replicates itself. When a pulse picker is triggered to pick every 80 000th pulse for subsequent amplification, all pulses look alike.

5.1 Spectral interferometry

Since the repetition rate of the amplified pulses is only 1 kHz, it is difficult to use f-to-2f or DFG method to detect CEP signal. In the year 2001, Kakehata *et al.* [13] proposed a method of SI to measure CEP for single shot pulses. The method uses a dispersive media to delay and spectrally broaden the pulse, so that the interference between the short wavelength portion and its second harmonic could be detected as a periodical curve, from which the CEP frequency could be calculated. The expression of the electric field of a Gaussian profile ultrashort laser pulse is

$$E_F(\omega) = \sqrt{2\pi} \exp\left\{-\left[(\omega - \omega_c) / 2\right]^2\right\} \exp(j\varphi_{CE}), \quad (5.1)$$

Here ω_c is the center frequency in its spectrum, and φ_{CE} is the CEP.

Considering the long wavelength portion and its harmonic, when passing through a dispersive media, the short wavelength portion delays τ and appears as a phase delay $\exp(-j\omega\tau)$. Calculating its 1st and 2nd order of electric dipole, the intensity of interference curve is:

$$I(\omega) \propto \left|P_\tau^{(1)}(\omega) + jP^{(2)}(\omega)\right|^2 \propto I_F + I_{SH} + 2[I_F I_{SH}]^{1/2} \cos[\omega\tau + \varphi_{CE} + \pi/2]. \quad (5.2)$$

For a specific dispersive media, the delay time τ is constant. So φ_{CE} is able to extract by Fourier transforming the interference signal. Moreover, the gap of the interference streak is inverse proportional to the delay time, which indicates that only short delay could get large streak gap for interferometers to identify.

The Fourier transform of interference signal (for clearance, the Fourier frequency is k) is:

$$F(I(\omega)) \propto \exp\left[\frac{k - \tau/2\pi}{2}\right]^2 \exp(j\varphi_{CE}), \quad (5.3)$$

$$\arg[F(I(\omega))|_{k=\tau/2\pi}] \propto \tan^{-1}(\varphi_{CE}). \quad (5.4)$$

In the real experiment, by introducing $\sim 1\%$ of the amplified pulses, about 10 μJ into a 1 mm thick sapphire plate white light continuum of an octave spanning is produced, then a BBO crystal is used to frequency double the infrared spectrum to generate spectral interference with the blue parts. The SI signal is collected by a spectrometer and is analyzed by the PC software. Fig.13 shows the interference spectrum at the center wavelength of 525nm with the bandwidth of 30nm which covers about 17 interference fringes. It must be mentioned that the prerequisite of the achievement of this interference spectrum is to lock the CEO of the seed pulses train emitted from Ti:sapphire oscillator. The phase-locked loop for feedback control the CEO of multiple-MHz repetition rate seed pulses is called "fast-loop", relatively, "slow-loop" designated to the electrical servo-control CEP for successive kHz repetition rate amplified pulses. It is obvious that there is no interference phenomenon in the spectrum of amplified pulses unless "fast-loop" turned on.

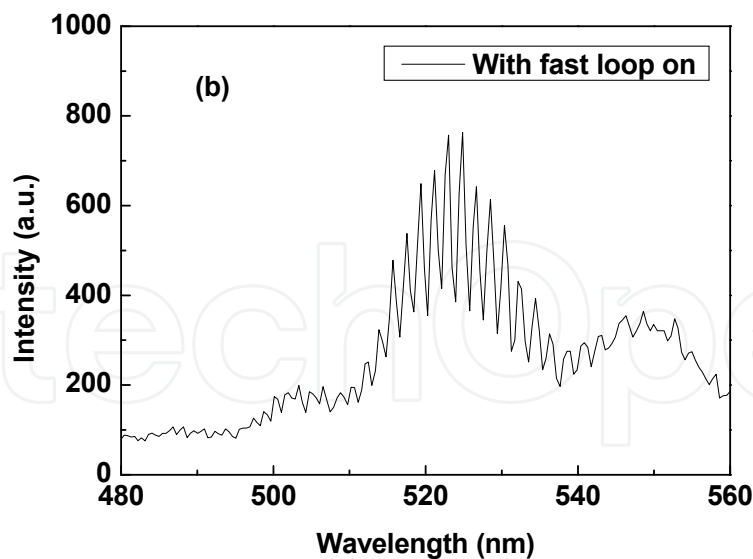

Fig. 13. The interference spectrum of amplified pulses

5.2 Control of CEP in amplified pulses

The CEP control process for amplified pulses is implemented by a real-time software running on a PC, which acquires the output of the interferometer (Ocean Optics, HR2000)

and output the control signal by D/A conversion through an DAQ card (National Instrument, PCI-6221). Firstly, the system samples the interference curve and applies FFT to spectrum region of interest to get CEP power and phase spectrum. Secondly, the peak frequency offset of CEP spectrum k is automatically evaluated from the Fourier spectrum so that the corresponding φ_{CE} could be calculated. From equation (9), the transfer function of 'slow loop' phase detection process is:

$$H_2(\varphi_{CE}(t))|_{\varphi_{CE} \ll 1} \approx K_2 \varphi_{CE}(t), H_2(s) \approx K_2 \frac{1}{s^2}. \quad (5.5)$$

The PI controller, $G_{c2}(s) = K_{p2} \cdot \left(1 + \frac{1}{T_{i2}s}\right)$, compensates the phase error and outputs control

signal for 'fast loop' to change its reference point so that both PLLs could be closed. As a result, the CEP of the amplified pulses can readily be controlled by both "fast" and "slow" feedback to the seed oscillator through phase locking electronics. To meet equation (4) and tune the controller's parameter for different experiment conditions, the design of controller must have adaptivity. An algorithm of auto-tuning method based on setpoint relay is applied to optimize P/I parameter for shortest rise time and minimum overshoot. Experiment shows that the auto-tuning method may have 2-3 times smaller CEP error than manually tune the parameters.

Fig.14 displays the locking results of amplified pulses with the slow loop on and off. In Fig 14, curve A shows CEP drift of the amplified pulses during 5 minutes when only locking the oscillator by 'fast loop', curve B is the result after locking 'slow loop'. It is clear that the CEP is changing greatly in the former state, while the rms error of CEP is only 53 mrad in the later one. The system is able to lock for over 3 hours. For even lower repetition rate lasers, although the SI method is still able to effectively detect CEP, the feedback loop bandwidth is limited by the repetition rate, so the performance of noise suppressing is also limited.

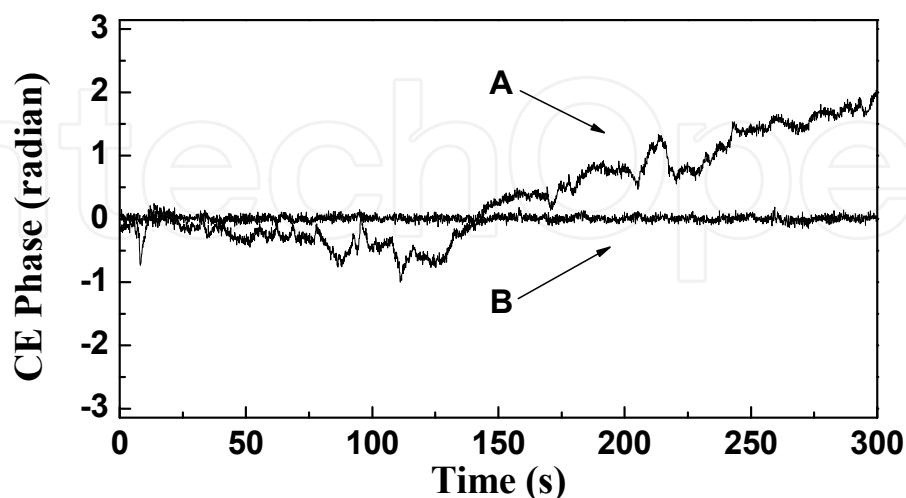

Fig. 14. Amplified pulses CEP varies by time, Curve A is only locking the oscillator; Curve B is locking two PLLs simultaneously.

6. Summary

Frequency comb techniques (stabilization of CEO in oscillator) have brought a truly revolutionary influence to the optical frequency metrology and precision spectroscopy since it emerged about ten years ago. Specially, in recent years a number of nonlinear physical processes dependent on electric field rather than intensity envelope of the pulse have been investigated, such as coherent control of atomic and molecular system, optimization of high harmonic generation, and dynamic of electron motion on femtosecond and attosecond time scales, where clearly the CEP stabilization in amplified pulses played an important role. We presented a novel monolithic 350MHz frequency comb system based on 0-to-f measurement technique with excellent long term phase lock, and realized stabilization of high energy pulses at 1kHz with the phase fluctuation less than 60 mrad. Accordingly, we believed that CEP stabilized femtosecond laser using advanced techniques will continue to open up new fields of applications in the future.

7. References

- [1] T. Brabec, and F. Krausz, "Intense few-cycle laser fields: Frontiers of nonlinear optics," *Rev. Mod. Phys.* 72, 545 (2000)
- [2] P.B. Corkum, "Plasma perspective on strong field multiphoton ionization," *Phys. Rev. Lett.*, 71, 1994-1997 (1993)
- [3] G. G. Paulus, F. Grasbon, H. Walther, P. Villoriesi, M. Nisoli, S. Stagira, E. Priori, and S. De Silvestri, "Absolute-phase phenomena in photoionization with few-cycle laser pulses." *Nature (London)* 414, 182 (2001)
- [4] C. G. Durfee, A. R. Rundquist, S. Backus, C. Herne, M. M. Murnane, and H. C. Kapteyn, "Phase matching of high order harmonics in hollow waveguides," *Phys. Rev. Lett.* 83, 2187 (1999)
- [5] C. Spielmann, N. H. Burnett, S. Sartania, R. Koppitsch, M. Schnurer, C. Kan, M. Lenzner, P. Wobrauschek, and F. Krausz, "Generation of coherent X-rays in the water window using 5-femtosecond laser pulses," *Science* 278, 661 (1997)
- [6] I. P. Christov, M. M. Murnane, and H. C. Kapteyn, "High-harmonic generation of attosecond pulses in the 'single-cycle' regime," *Phys. Rev. Lett.* 78, 1251 (1997)
- [7] Paul P M, Toma E S, Breger P, et al. Observation of a train of attosecond pulses from high harmonic generation. *Science*, 2001, 292(5522): 1689-1692
- [8] M. Hentschel, R. Kienberger, Ch. Spielmann, G. A. Reider, N. Milosevic, T. Brabec, P. Corkum, U. Heinzmann, M. Drescher and F. Krausz, "Attosecond metrology," *Nature* 414, 509-513 (2001).
- [9] R. Kienberger, M. Uiberacker, E. Goulielmakis, A. Baltuska, M. Drescher, F. Krausz, "Single sub-fs soft-x-ray pulses: generation and measurement with the atomic transient recorder," *J. Modern Optics* 20,261 (2005)
- [10] R. Kienberger, M. Hentschel, M. Uiberacker, Ch. Spielmann, M. Kitzler, A. Scrinzi, M. Wieland, Th. Westerwalbesloh, U. Kleineberg, U. Heinzmann, M. Drescher, and F. Krausz. "Steering attosecond electron wave packets with light," *Science* 297, 1144 (2002)
- [11] M. Drescher, M. Hentschel, R. Kienberger, M. Uiberacker, V. Yakovlev, A. Scrinzi, Th. Westerwalbesloh, U. Kleineberg, U. Heinzmann and F. Krausz., "Time-resolved atomic inner-shell spectroscopy," *Nature* 419, 803 (2002)
- [12] Baltuška A, Udem Th, Uiberacker M, et al. Attosecond control of electronic processes by intense light fields. *Nature*, 2003, 421(6293): 611-615
- [13] F. Krausz, "Attosecond spectroscopy comes of age," *Opt. Photon. News* 13, 62-68 (20)

- [14] Baltuska A, Wei Z, Pshenichnikov M S, et al. Optical pulse compression to 5 fs at a 1-MHz repetition rate. *Opt Lett*, 1997, 22(2): 102-104
- [15] U. Morgner, F. X. Kärtner, S. H. Cho, Y. Chen, H. A. Haus, J. G. Fujimoto, E. P. Ippen, V. Scheuer, G. Angelow and T. Tschudi, "Sub-two-cycle pulses from a Kerr-lens modelocked Ti:sapphire laser," *Opt. Lett.* 24, 411-413(1999).
- [16] Y. Kobayashi, K. Torizuka, Zhiyi. Wei, Kobayashi Y, Torizuka K, Control of relative carrier-envelope phase slip in femtosecond Ti: sapphire and Cr: forsteritelasers. *Opt. Lett.* 28, 746 (2002)
- [17] Z. Wei, Y. Kobayashi, K. Torizuka, Relative carrier-envelope phase dynamics between passively synchronized Ti: sapphire and Cr:forsterite lasers, *Opt. Lett.*, 27, 2121(2001).
- [18] Telle H R, Steinmeyer G, Dunlop A E, et al. Carrier-envelope offset phase control: A novel concept for absolute optical frequency measurement and ultrashort pulse generation. *Appl Phys B*, 1999, 69(4): 327-332
- [19] A. Apolonski, A. Poppe, G. Tempea, C. Spielmann, T. Udem, R. Holzwarth, T. W. Hänsch, and F. Krausz, "Controlling the phase evolution of few-cycle light pulses" *Phys. Rev.Lett.* 85, 740 (2000)
- [20] Jones D J, Diddams S A, Ranka J K, et al. Carrier-envelope phase control of femtosecond mode-locked lasers and direct optical frequency synthesis. *Science*, 2000, 288(5466): 635-639
- [21] Han H N, Wei Z Y, Zhang J et al., Measurement of Carrier-Envelope-Offset in the femtosecond Ti:sapphire laser, *Acta Physica Sinica (in Chinese)*, 2005, 54(1):155~158
- [22] Mucke O. D., Kuzucu O., Wong F. N. C., Ippen E. P., Kaertner F. X., Foreman S.M., Jones D. J., Ma L. S., Hall J. L., Ye J., Experimental implementation of optical clockwork without carrier-envelope phase control, 29 2806 *Opt. Lett.* (2004)
- [23] Zinllnellmann M., Gohle Ch, Holzwarth R, Udem Th, Hansch T., Optical clockwork with an offset-free difference-frequency comb: accuracy of sum- and difference-frequency generation *Opt. Lett.* 29 310(2004)
- [24] Fuji T, Apolonski A, Krausz F. Self-stabilization of carrier-envelope offset phase by use of difference-frequency generation. *Opt Lett*, 2004, 29(6): 632-634
- [25] Takao Fuji, Jens Rauschenberger et, Monolithic carrier-envelope phase-stabilization scheme, *Opt. Lett.* 30 332(2005)
- [26] Han H N, Zhao Y Y, Zhang W et al., Measurement of Carrier-Envelope Phase of few cycles Ti:sapphire laser by Difference Frequency Technique, *Acta Physica Sinica (in Chinese)*, 2007, 56(5):2756~2759
- [27] J. C. Knight, T. A. Birks, P. St. J. Russell, and D. M. Atkin. "All-silica single-mode fiber with photonic crystal cladding". *Opt. Lett.* 19, 1547-1549 (1996)
- [28] J. K. Ranka, R. S. Windeler, and A. J. Stentz. "Visible continuum generation in air silica microstructure optical fibers with anomalous dispersion at 800nm". *Opt. Lett.* 1, 25-27 (2000)
- [29] Stephane Coen, Alvin Hing Lun Chau, Rainer Leonhardt, and John D. Harvey. "White-light supercontinuum generation with 60-ps pump pulses in a photonic crystal fiber". *Opt. Lett.* 17, 1356-1358 (2001)
- [30] L. Provino, J. M. Dudley, H. Maillotte, N. Grossard, R. S. Windeler, and B. J. Eggleton. "Compact broadband continuum source based on microchip laser pumped microstructured fiber". *Electron. Lett.* 37, 558-560 (2001)
- [31] A. V. Husakou and J. Herrmann. "supercontinuum generation , four-wave mixing, and fission of higher-order solitons in photonic-crystal fibers". *J. Opt. Soc. Am. B*, 9, 2171-2182 (2002)

- [32] H. N. Han, W. Zhang, P. Wang, D. H. Li, and Z.Y. Wei, "Precise control of femtosecond Ti:sapphire laser frequency comb," *Acta Physica Sinica(in Chinese)* 56, 2760-2764 (2007).
- [33] H. N. Han, W. Zhang etc, Control of carrier-envelope phase offset in femtosecond laser with PLL and TV-Rb clock, *Acta Physica Sinica(in Chinese)* 56, 291 (2007)
- [34] W. Zhang, H. N. Han, P. Wang, and Z. Y. Wei, "Stabilization and phase control of femtosecond Ti:sapphire laser with a repetition rate of 90MHz," in 27th International Congress on High-Speed Photography and Photonics, Proc.of SPIE 6279, 62793X1-X8 (2007)
- [35] Zhang Wei, Han Hainian, Zhao Yanying, Du Qiang, Wei Zhiyi, "A 350MHz Ti:sapphire laser comb based on monolithic scheme and absolute frequency measurement of 729nm laser" *Opt. Exp.* 17,6059-6067 (2009)
- [36] Kakehata M, Fujihira Y, Takada H, et al. Measurements of carrier-envelope phase changes of 100-Hz amplified laser pulses. *Appl Phys B*, 74(9): 43 (2002)
- [37] Kakehata M, Takada H, Kobayashi Y, et al. Single-shot measurement of carrier-envelope phase changes by spectral interferometry. *Opt Lett*, 26 1436(2001)
- [38] Chang Z. Carrier-envelope phase shift caused by grating-based stretchers and compressors. *Appl Opt*, 45(32): 8350 (2003)
- [39] Sutter D H, Steinmeyer G, Gallmann L, et al. Semiconductor saturable absorber mirror assisted Kerr-lens mode-locked Ti:sapphire laser producing pulses in the two-cycle regime. *Opt Lett*, 24, 631(1999)
- [40] Ell R, Fujimoto J G, Scheuer V, et al. Generation of 5-fs pulses and octave spanning spectra directly from a Ti:sapphire laser. *Opt Lett*, 26, 373 (2001)
- [41] Jung I D, Kartner F X, Matuschek N, et al. Self-starting 6.5-fs pulses from a Ti:sapphire laser. *Opt Lett*, 22, 1009(1997)
- [42] Wei Z Y. Solid state self-mode-locking Ti:Al₂O₃ laser with chirp mirrors. In: Academic Report Memoir of the 14th National Laser (in Chinese), Beijing, 1999
- [43] Liao R, Wen J H, Liu Z G, et al. Generation sub-10-fs pulse from KLM Ti:sapphire laser. *Chin Sci Bull (in Chinese)*, 47, 345(2002)
- [44] Zhang Wei, Han Hai-Nian, Teng Hao, and Wei Zhi-Yi, "Generation of 10 fs Ti:sapphire laser at repetition rate of 525MHz and measurement of carrier-envelope phase frequency" *Chinese Physics B Vol.18*,1105(2009)
- [45] ZHAO YanYing, WANG Peng, ZHANG Wei et al, Generation of sub-7 fs laser pulse directly from a compact Ti:sapphire laser with chirped mirrors *Sci China-Phys Mech Astron* 50, 1-6(2007)
- [46] Han H N, Zhao Y Y, Zhang W et al. A new monolithic measurement scheme for carrier-envelope offset frequency with enhanced signal-to-noise ratio, The 6th Asia Pacific Laser Symposium(APLS2008), Nagoya, Japan
- [47] J. Stenger, H. R. Telle, " Intensity-induced mode shift in a femtosecond laser by a change in the nonlinear index of refraction", *Opt. Lett.* 25, 1553(2000)
- [48] Kevin W. Holman, R. Jason Jones, Adela Marian, Steven T. Cundiff, Jun Ye, "Detailed studies and control of intensity-related dynamics of femtosecond frequency combs from mode-locked Ti:sapphire lasers", *IEEE Journal of Selected Topics in Quantum Electronics* 9,1018 (2003)
- [49] F. W. Helbing, G. Steinmeyer, J. Stenger, H. R. Telle, U. Keller, "Carrier-envelope-offset dynamics and stabilization of femtosecond pulses", *Appl. Phys. B74(Suppl.)* S35 (2002)
- [50] T. M. Fortier, D. J. Jones, J. Ye, and S. T. Cundiff, "Highly Phase Stable Mode-Locked Lasers," *IEEE J. Selected Top. Quant. Electron* 9, 1002-1010 (2003).

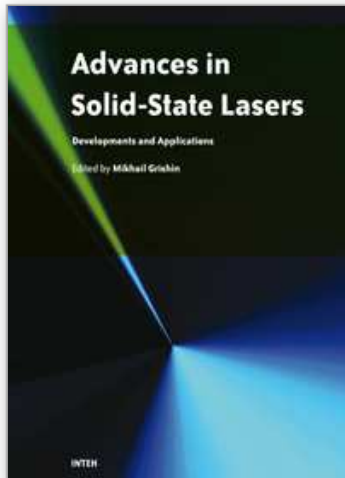

Advances in Solid State Lasers Development and Applications

Edited by Mikhail Grishin

ISBN 978-953-7619-80-0

Hard cover, 630 pages

Publisher InTech

Published online 01, February, 2010

Published in print edition February, 2010

Invention of the solid-state laser has initiated the beginning of the laser era. Performance of solid-state lasers improved amazingly during five decades. Nowadays, solid-state lasers remain one of the most rapidly developing branches of laser science and become an increasingly important tool for modern technology. This book represents a selection of chapters exhibiting various investigation directions in the field of solid-state lasers and the cutting edge of related applications. The materials are contributed by leading researchers and each chapter represents a comprehensive study reflecting advances in modern laser physics. Considered topics are intended to meet the needs of both specialists in laser system design and those who use laser techniques in fundamental science and applied research. This book is the result of efforts of experts from different countries. I would like to acknowledge the authors for their contribution to the book. I also wish to acknowledge Vedran Kordic for indispensable technical assistance in the book preparation and publishing.

How to reference

In order to correctly reference this scholarly work, feel free to copy and paste the following:

Zhiyi Wei, Hainian Han, Wei Zhang, Yanying Zhao, Jiangfeng Zhu, Hao Teng and Qiang Du (2010). Measurement and Control of Carrier-Envelope Phase in Femtosecond Ti:sapphire Laser, *Advances in Solid State Lasers Development and Applications*, Mikhail Grishin (Ed.), ISBN: 978-953-7619-80-0, InTech, Available from: <http://www.intechopen.com/books/advances-in-solid-state-lasers-development-and-applications/measurement-and-control-of-carrier-envelope-phase-in-femtosecond-ti-sapphire-laser>

INTECH
open science | open minds

InTech Europe

University Campus STeP Ri
Slavka Krautzeka 83/A
51000 Rijeka, Croatia
Phone: +385 (51) 770 447
Fax: +385 (51) 686 166
www.intechopen.com

InTech China

Unit 405, Office Block, Hotel Equatorial Shanghai
No.65, Yan An Road (West), Shanghai, 200040, China
中国上海市延安西路65号上海国际贵都大饭店办公楼405单元
Phone: +86-21-62489820
Fax: +86-21-62489821

© 2010 The Author(s). Licensee IntechOpen. This chapter is distributed under the terms of the [Creative Commons Attribution-NonCommercial-ShareAlike-3.0 License](#), which permits use, distribution and reproduction for non-commercial purposes, provided the original is properly cited and derivative works building on this content are distributed under the same license.

IntechOpen

IntechOpen