

We are IntechOpen, the world's leading publisher of Open Access books Built by scientists, for scientists

4,800

Open access books available

122,000

International authors and editors

135M

Downloads

Our authors are among the

154

Countries delivered to

TOP 1%

most cited scientists

12.2%

Contributors from top 500 universities



WEB OF SCIENCE™

Selection of our books indexed in the Book Citation Index
in Web of Science™ Core Collection (BKCI)

Interested in publishing with us?
Contact book.department@intechopen.com

Numbers displayed above are based on latest data collected.

For more information visit www.intechopen.com



Dynamic Modelling of a Wind Farm and Analysis of Its Impact on a Weak Power System

Gastón Orlando Suvire and Pedro Enrique Mercado
*Instituto de Energía Eléctrica – Universidad Nacional de San Juan
 Argentina*

1. Introduction

Wind power generation is considered the most economic viable alternative within the portfolio of renewable energy resources. Among their advantages are the large number of potential sites for plant installation and the rapidly evolving technology with many suppliers offering from the individual turbine set to even turnkey projects. On the other hand, wind energy projects entail high initial capital costs and, in operation, a lack of controllability on the discontinuous or intermittent resource. In spite of these disadvantages, their incorporation is growing steadily, a fact that is making the utilities evaluate the various influencing aspects of wind power generation onto power systems.

Throughout the world there are large scarcely populated areas with good wind power potential where the existing grids are small or weak, due to the small population. A typical example is the large expanse of the Argentine Patagonia, with small cities clustered on the coastal areas and the Andean valleys. In these areas the capacity of the grid can very often be a limiting factor for the exploitation of the wind resource. One of the main problems concerned with wind power and weak grids is the voltage fluctuations. Several factors contribute to the voltage fluctuations in the terminals of a wind turbine generator (Suvire & Mercado, 2006; Slootweg & Kling, 2003; Ackermann, 2005; Chen & Spooner, 2001; Mohod & Aware, 2008; Smith et al., 2007): the aerodynamic phenomena, i.e., wind turbulence, tower shadow, etc.; the short-circuit power at the connection points; the number of turbines and the type of control. Besides, wind turbines may also cause voltage fluctuations in the grid if there are relatively large current variations during the connection and disconnection of turbines. With these aspects in mind, it turns necessary to ponder the information stemming from models that simulate the dynamic interaction between wind farms and the power systems they are connected to. Such models allow performing the necessary preliminary studies before connecting wind farms to the grid.

The purpose of this chapter is to show by means of simulations the voltage fluctuations caused by a wind farm in a weak power system. A model for dynamic performance of wind farms is presented, which takes into account the dynamic behaviour of an individual wind turbine and the aggregation effect of a wind farm (i.e., the larger the wind farm, the smoother the output waveforms). In addition, the wind speed model and wind turbine models are briefly presented. Validation of models and simulations of the interactions between the wind farm and the power system are carried out by using SimPowerSystems of SIMULINK/MATLAB™.

Source: Dynamic Modelling, Book edited by: Alisson V. Brito,
 ISBN 978-953-7619-68-8, pp. 290, January 2010, INTECH, Croatia, downloaded from SCIYO.COM

2. Wind system model

The main subsystems in a wind system model are the wind, the turbine and the farm. Fig. 1 shows this general structure with its main composing models.

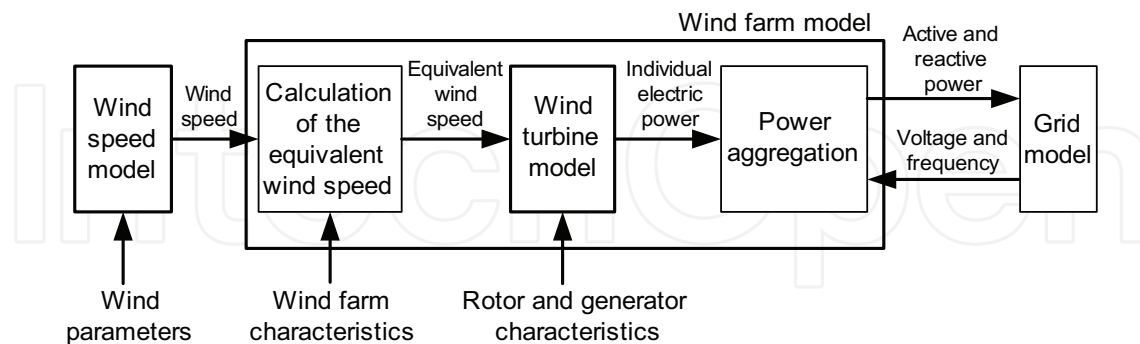

Fig. 1. General structure of a wind system model

From left to right, the wind speed model produces a wind speed sequence whose parameters are chosen by the user according to the wind pattern of the region. Then, the equivalent wind speed for the individual turbines is calculated using both the wind speed and the wind farm characteristics. The equivalent wind speeds are used to calculate the electric power generated by individual turbines, using the wind turbine model and both rotor and generator characteristics. The electric power outputs of the individual turbines are added using the power aggregation block. Thus, the total power of the wind farm injected to the power system is found.

2.1 Wind speed model

In the long-term range, i.e., for consideration over days and weeks, macro-meteorological influences dominate the wind speed. In the short-term range from several seconds up to minutes, fluctuations of particular interest here occur, e.g., in the form of wind gusts. In the medium time range the wind speed can be viewed as more or less stationary (Hassan & Sykes, 1985; Welfonder et al., 1997). As a result, mean values and mean standard deviations of the wind speed can be determined over a range of hours. In the process, the fluctuations of this mean wind speed and the superimposed short-term wind-speed fluctuations can be examined and modelled, independent of each other. The research on wind power conversion systems, especially the development of control solutions, involves the modelling of wind speed as a random process. Wind speed is considered as consisting of two elements (Nichita et al., 2002; Leithead et al., 1991): a slowly varying mean wind speed of hourly average; and a rapidly varying turbulence component. Since this chapter is focused on voltage fluctuations caused by wind generation, only the rapidly varying turbulence component is modelled and a mean wind speed is considered constant throughout the observation period. This component is modelled by a normal distribution with a null mean value and a standard deviation that is proportional to the current value of the mean wind speed. The block diagram of Fig. 2 is used as the referential base for modelling the wind speed behaviour (Welfonder et al., 1997).

The source for wind speed variation is assumed to be normally distributed white noise caused by a generator of random numbers. The output signal thus obtained shows the null mean value and a normalized standard deviation equal to one.

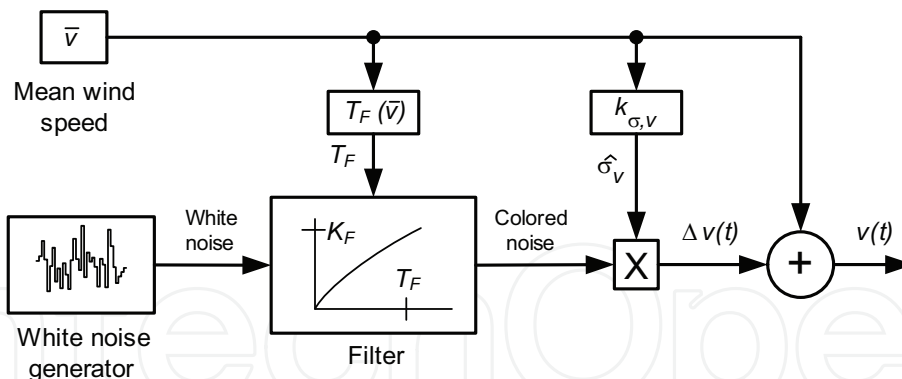

Fig. 2. Model for simulating the wind speed behaviour

However, since the wind speed $v(t)$ cannot change abruptly (because of physical reasons), but rather continuously, the white noise is smoothed using a properly designed signal-shaping filter with transfer function $H_F(j\omega)$. This way, it is transformed into a colored noise. The signal-shaping filter used in the model has a gain K_F and a time constant T_F . With a gain K_F of this shaping filter adapted to the filter time constant T_F , the standard deviation of the colored noise signal turns to be equal to one as well. The fluctuating part of the wind speed $\Delta v(t)$ is obtained by multiplying this normalized colored noise signal and the respective wind speed dependent standard deviation $\hat{\sigma}_v$. Then, the respective mean speed \bar{v} is added to this value. The characteristics of the artificial wind speed signals determined in this way are dependent on the wind parameters.

The mean wind speed and the standard deviation are linearly related with the constant $k_{\sigma,v}$

$$\hat{\sigma}_v = k_{\sigma,v} \cdot \bar{v} \quad (1)$$

$k_{\sigma,v}$ is found experimentally and it depends on the characteristics of the place. Typical values of $k_{\sigma,v}$ are 0.1...0.15 for the coastal and offshore sites and 0.15...0.25 for the cases where the site topography is more important.

If the transfer function of the shaping filter is specified according to (Welfonder et al., 1997), e.g.

$$H_F(j\omega) = \frac{K_F}{(1 + j\omega T_F)^{5/6}} \quad (2)$$

then, a very good correspondence between the measured and the simulated values is obtained. The amplification factor K_F is computed on the condition that the colored noise from the filter has a standard deviation value equal to one. This condition is set by the following relationship between K_F and T_F .

$$K_F = \sqrt{\frac{2\pi}{B\left(\frac{1}{2}, \frac{1}{3}\right)} \frac{T_F}{T}} \quad (3)$$

where T is the sampling period and B is the beta function, also called the Euler integral of the first kind.

The time constant T_F of the shaping filter is chosen as:

$$T_F = \frac{L}{V} \quad (4)$$

where L is the turbulence length scale and it depends on the site characteristics. Typical values of L are 100...200m for coastal and offshore sites and 200...500m in cases where site topography is more important.

2.2 Wind turbine model

The produced electrical power from wind turbines does not have the same behaviour in terms of variation as the wind. Wind turbines are dynamic generators with several components that influence the power conversion from the wind. The dynamics of the wind turbine filter out the high frequency power variations but it also includes new components due to its dynamics itself.

Wind turbines can in most cases be represented by a generic model with its main parts: the rotor and the generation system. These model elements are presented below.

Rotor

The turbine rotor reduces the air speed and at the same time transforms the absorbed kinetic energy of the air into mechanical power, P_{MECH} . The mechanical power of the wind turbine is given using the following equation:

$$P_{MECH} = \frac{1}{2} \rho A v^3 C_p(\lambda, \beta) \quad (5)$$

where ρ is the air density, A the area swept by the rotor, v is the wind speed, C_p is the power coefficient, β is the blade angle of the wind turbine, and λ is the tip-speed ratio, which is defined by:

$$\lambda = \frac{\omega_{turb} R}{V} \quad (6)$$

where ω_{turb} is the turbine rotational speed and R is the rotor radius.

The power coefficient C_p depends on the aerodynamic characteristics of the wind turbine. The following generic equation can be used to model C_p (Siegfried, 1998):

$$C_p(\lambda, \beta) = 0.5 \left(\frac{116}{\lambda_i} - 0.4\beta - 5 \right) e^{-\frac{21}{\lambda_i}} \quad (7)$$

where

$$\lambda = \frac{\omega_{turb} R}{V} \quad (8)$$

It may be noted that C_p is a highly nonlinear power function of λ and β , where λ in turn is dependent of the turbine rotational speed and the wind speed.

Generation System

There are different types of generation system. According to the rotational speed of the rotor, wind generation systems can be classified into two types: fixed-speed systems and variable-speed systems (Slootweg & Kling, 2003; Jenkins et al., 2000).

Fixed-speed systems

In fixed-speed machines, the generator, usually of induction with squirrel-cage rotor, is directly connected to the grid. The frequency of the grid establishes the rotational speed of the generator. The slow rotational speed of the turbine's blades is transmitted to the generator by means of a gear box.

Squirrel-cage induction generators always require reactive power. Thus, the use of reactive power is always provided by capacitors so as to reach a power factor close to one.

Fixed-speed systems have the advantage of simplicity and low cost and the disadvantage of requiring reactive power supply for the used induction generators. Fig. 3 shows a model of fixed-speed systems for wind turbines. This model consists mainly of the squirrel-cage induction generator and the compensating capacitors. For the generator, standard models of this type of machine are usually employed.

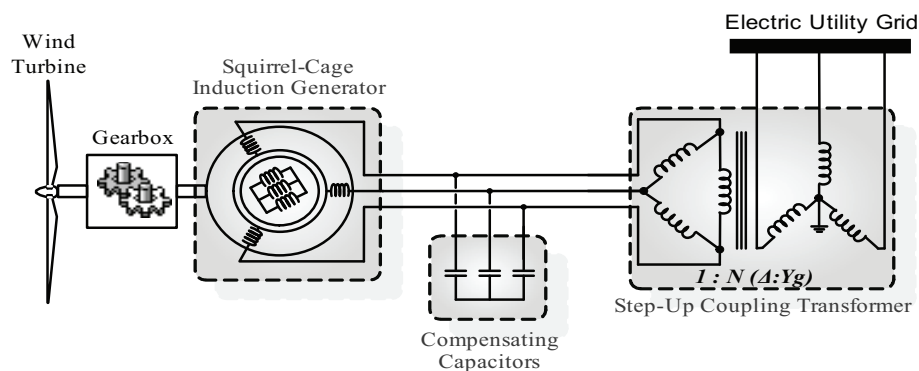

Fig. 3. Fixed-speed systems

Variable-speed systems

Variable-speed systems usually use power electronics to connect the generator with the grid, what makes it possible to uncouple the rotational speed of the rotor from the frequency of the grid, hence, allowing the rotational speed of the rotor to depend only on the speed of the wind. Since power is transmitted through power electronic converters, there is significant electric loss. However, there are some important advantages using variable speed, such as: a better energy exploitation; a decrease in mechanical loss, which makes possible lighter mechanical designs; and a more controllable power output (less dependent on wind variations). In variable-speed systems, wind turbines mainly use some of the following generating systems:

a. Direct-driven synchronous generator

In this system, the generator is completely uncoupled from the grid by means of power electronic converters connected to the winding of the stator and so, it does not need a gear box to connect to the grid. On the grid's side, the converter used is a voltage source converter. On the generator's side, it can be a voltage source converter or rectifier diodes. Fig. 4 shows a model of this type of generating system.

b. Doubly-fed induction generator (wound rotor)

In these systems, the excitation windings of the generator are fed with an external frequency through an ac/dc/ac converter; in this way, the rotor speed can be uncoupled from the electric frequency of the system. This variable-speed system have the advantage over direct-driven synchronous generators of using power electronic converters that can be reduced in size, owing to the fact that these can only be found in the circuit of the rotor. However, these systems have the disadvantage of necessarily requiring a gear box for the connection to the grid, what can reduce reliability. Fig. 5 shows a model of this type of generating system.

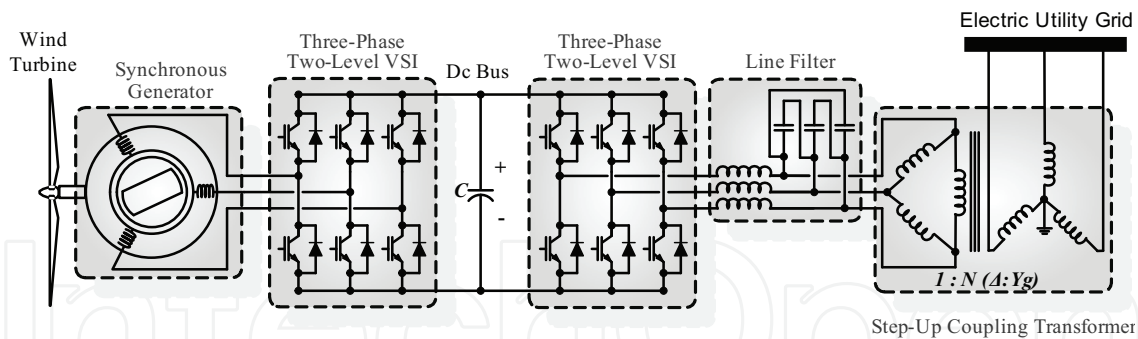

Fig. 4. Variable-speed system with direct-driven synchronous generator

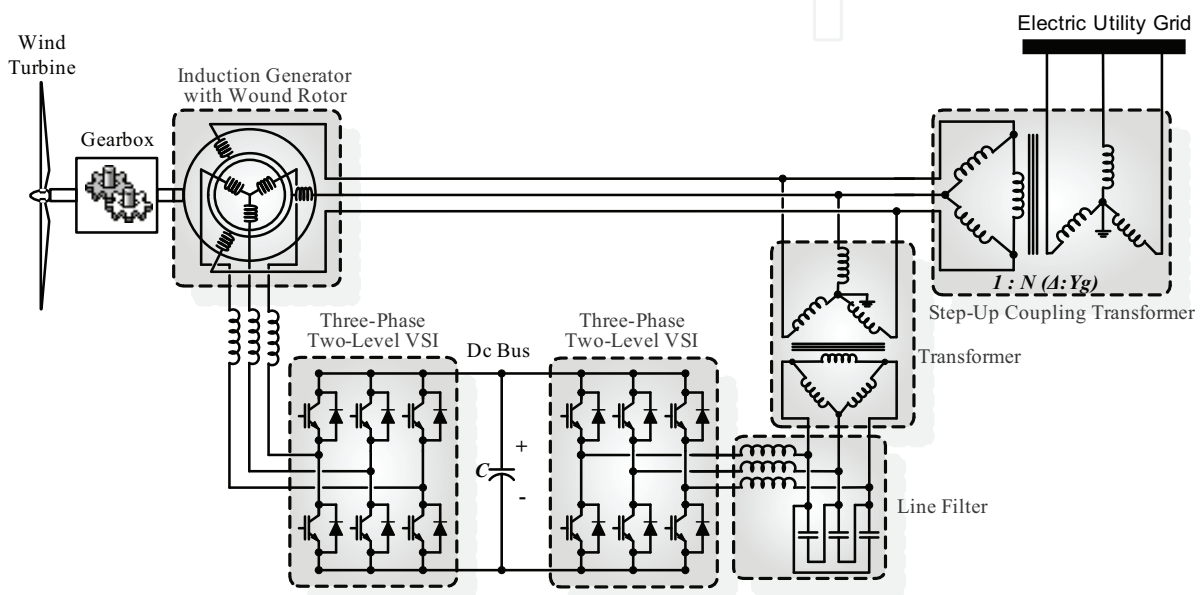

Fig. 5. Variable-speed system with doubly-fed induction generator

2.2.1 Simplified model of fixed-speed wind turbines

The wind turbine topology used in this study is the type of the fixed-speed wind turbine. This turbine type is equipped with an induction generator (squirrel cage or wound rotor) that is directly connected to the grid. Detailed models for wind turbines are complex, with differential equations requiring much computational work. For certain studies (e.g., power system dynamics) these models can not be applied, which calls instead for simplified models. The development of simplified models implies a compromise between, on the one hand, making substantial simplifications to reduce the computational load and, on the other hand, keeping the necessary adequacy to allow predicting the influence of wind power on the dynamic behaviour of the system. A simplified equivalent model for power behaviour of a typical fixed-speed wind turbine is presented below, based on an equivalent transfer function developed in (Soens et al., 2005; Delmerico et al., 2003).

For fixed values of mean wind speed, the entire system is assumed to be linear and, thus, can be approximated by a simple transfer function. This transfer function must be a first order low-pass filter for low wind speeds (i.e., a value below the rated wind speed) and a higher order function for high wind speeds (higher values than the rated wind speed) (Soens et al., 2005; Delmerico et al., 2003). Rated wind speed is the wind speed for which the

turbine generates its rated power. Fig. 6 shows the model used. The input of the function is the available wind speed. The output is the turbine's power available for electricity generation. Considering the upper part of Fig.6, the wind speed is low-pass filtered and converted into power using the turbine's power curve. The time constant of the low-pass filter depends on the average wind speed. For this simplified model, it is assumed constant. The power curve of the wind turbine is depicted in Fig. 7.

The power curve has an upper limit for the output power, which is equal or near the rated power (i.e., 1pu). The upper input of the summator in Fig. 6 remains nearby at 1pu for high wind speeds. The effect of wind speed fluctuations at rated power operation is taken into account by a second transfer function (lower part of Fig. 6).

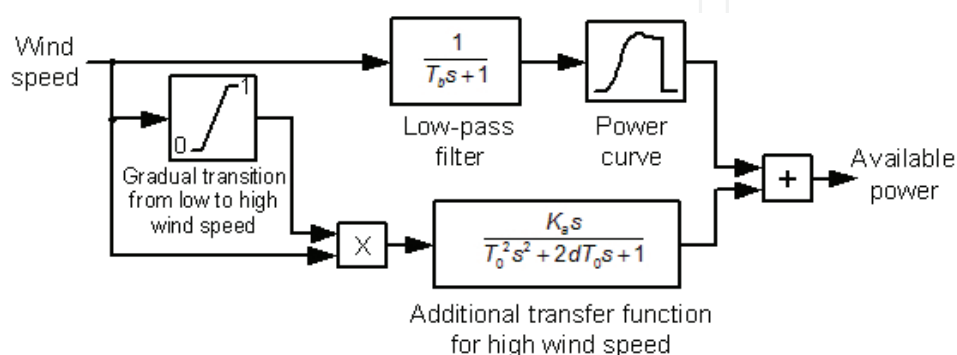

Fig. 6. Equivalent Transfer Function for the wind turbine model

The simplified model contains a gradual transition between the low wind speed and the high wind speed region. For wind speeds below 90% of rated wind speed, the transfer function for high wind speeds is not regarded (factor 0). For wind speeds above 100% of rated wind speed, the transfer function for high wind speeds is fully taken into account (factor 1). A linear interpolation is used for the intermediate wind speeds.

The parameters of the equivalent transfer function were obtained through simulations. The output of the equivalent transfer function was compared with the output of the detailed model of a wind turbine included in the library of the SimPowerSystems/Simulink. In this way, adjustments were progressively made on the parameters of the equivalent function until obtaining a good fit between both models.

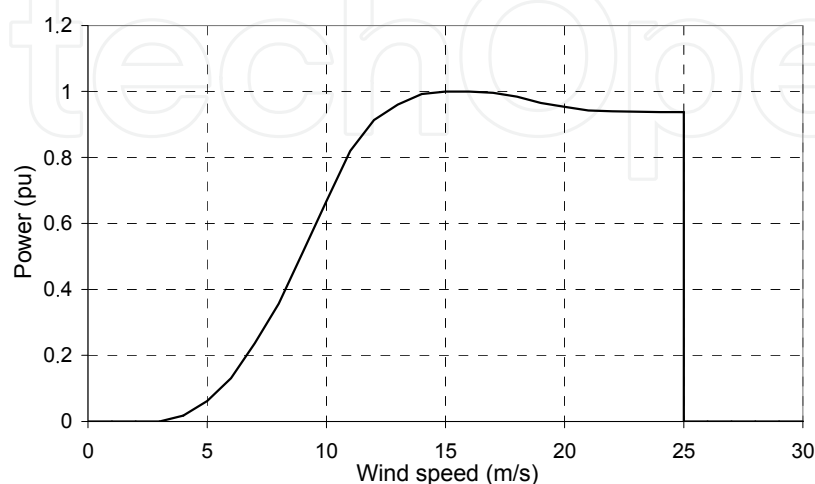

Fig. 7. Power curve of the wind turbine

2.3 Wind farm model

The mathematical model used for the wind farm behaviour in power systems is presented in this section. Typically, the number of wind turbines in a wind farm is high. In fact, a large wind farm can feature hundreds of wind turbines. Therefore, only for wind farm projects it is necessary to analyze in detail the entire generating facility, with each wind turbine represented individually.

In studies where the objective is to verify the influence of the wind farm on the electrical system, the model of every individual turbine of the wind farm would need excessively long processing times and a very robust computational infrastructure. In such studies, the wind farm is represented by an equivalent model from the viewpoint of the electrical system (Pavinatto, 2005; Pálsson et al., 2004; Pöller & Aechilles, 2003).

The simplest way to represent the wind farm is to model the entire farm as an equivalent single wind turbine (Pálsson et al., 2004). This approach assumes that the power fluctuations from each wind turbine are all equal throughout the farm. This assumption, however, does not reflect reality, because the power fluctuations of a wind farm are relatively smaller than those of a wind turbine. Another way to model the wind farm is through a detailed modelling of the farm and considering factors such as the coherence and the correlation of wind turbulence as the presented in (Rosas, 2003; Sørensen et al., 2007). These models imply a heavy load of mathematical modelling and sizable hardware to process them. The model presented in this work takes into account the aggregation effect of the wind farm using an equivalent for the wind added to groups of wind turbines in the farm (Pavinatto, 2005). The model thus conformed renders a good approximation of the behaviour of the wind farm, from the electric system viewpoint. As an advantage, the need for computational resources is reduced.

In order to take into account the aerodynamic effects associated to the layout of wind turbines in the farm, the scheme of Fig. 8 has been considered. The wind turbines of the first row of M turbines take a part of the kinetic energy of the wind. Therefore, the wind speed for the second row is reduced, and so on in the following rows. This speed decrease is illustrated in Fig. 9.

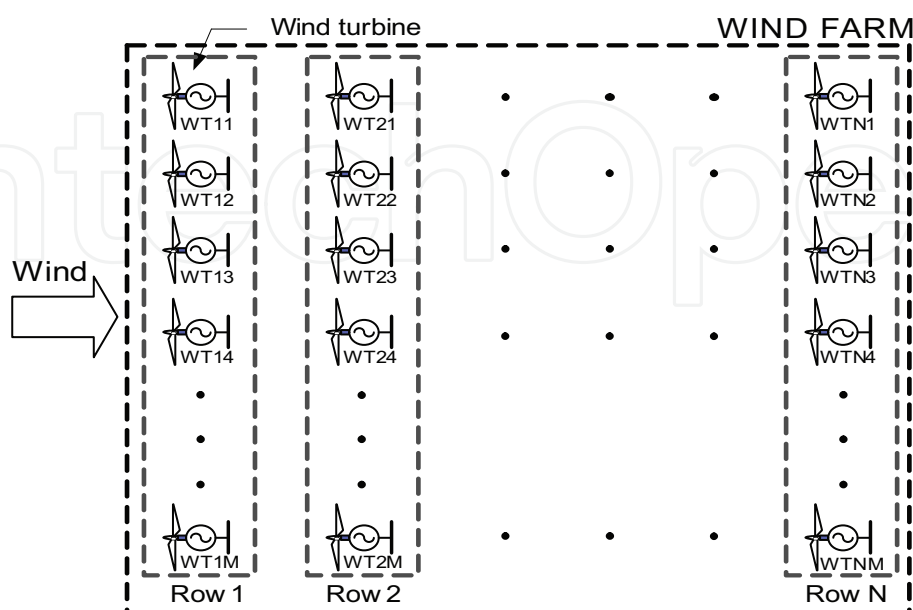

Fig. 8. Layout of a typical wind farm

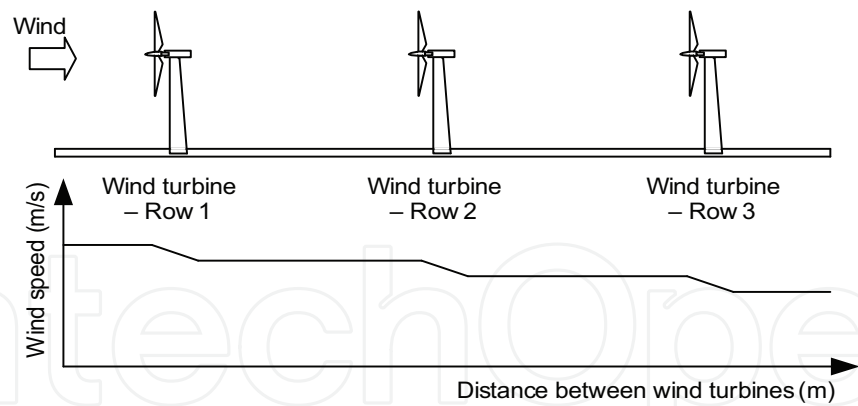

Fig. 9. Decrease of the wind speed due to the aerodynamic shadow effect of a turbine upon the following one

Reference (Frandsen et al., 2004) presents several methods to quantify this wind speed decrease. Typically, this speed reduction as the wind passes through the farm is characterized by the general pattern of Fig. 10.

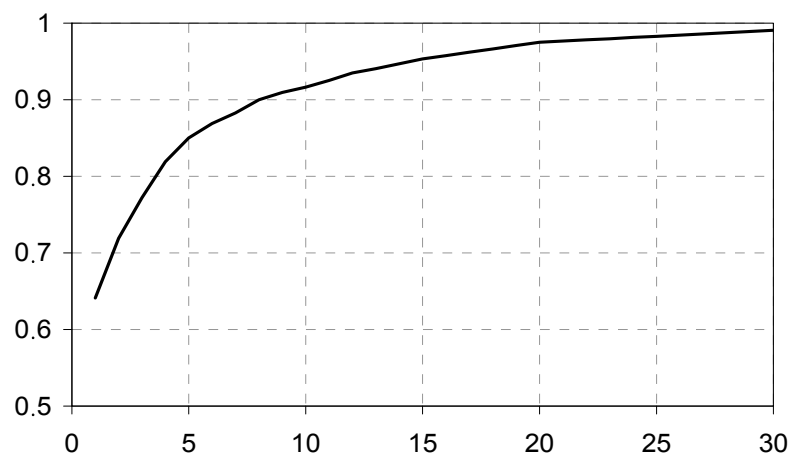

Fig. 10. Comparison of wind speed in two rows of wind turbines

In addition to the phenomenon of wind speed reduction, the effect of a temporary delay in the variations of the wind speed in these turbines is a contributing factor as well. That is, the turbines of the second row experience the wind speed variations of first row after a certain time, called the propagation time, which depends on the wind speed and the separating distance between turbines.

2.3.1 Calculation of the equivalent wind speed

For calculations, each row of turbines is considered as a single equivalent turbine, subjected to the effects from the wind speed decrease and propagation time. Equations (9) to (11) are used for modelling the wind speed on each turbine row (Pavinatto, 2005; Pálsson et al., 2004). The time series of wind speed for the first row is as follows:

$$v_{eq_s}(t) = \bar{v} + \frac{v(t) - \bar{v}}{\sqrt{M}} \quad (9)$$

where $v_{eq_s}(t)$ is the time series of the equivalent wind speed for the first row; $v(t)$ is the wind speed simulated in modeling; \bar{v} is the mean wind speed (for ten minutes, in this case) and M is the number of wind turbines for each row.

For the consecutive rows, the following expression is used:

$$v_{eq_sk}(t, k) = \left[v_{eq_s}(t + t_p) \right] a_r^{k-1} \quad (10)$$

$$t_p(k) = \frac{D(k-1)}{\bar{v}} \quad (11)$$

where k is the row number; $v_{eq_sk}(t, k)$ is the series of values of the equivalent wind speed for row k ; a_r is the coefficient that represents the reduction effect of the wind speed; $t_p(k)$ is the propagation time for row k , and D is the separating distance between rows in the farm.

The series of wind speed obtained for each row is applied to the dynamic simplified model of the wind turbine presented before.

2.3.2 Power aggregation

The output power of the wind turbine is multiplied by the number of wind turbines of the row, M . Thus, the total power of the row is obtained (P_{WT}). Finally, the corresponding values for the N rows are added up to attain the total power generated by the wind farm (P_{WF}). The overall structure of the wind farm model is presented in Fig. 11.

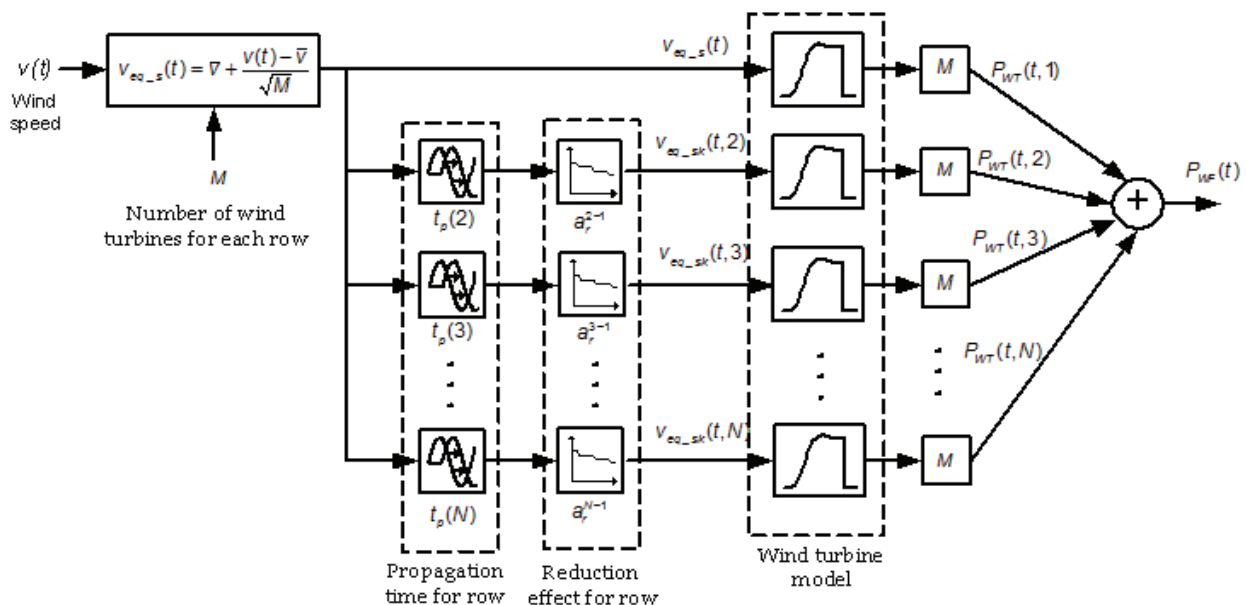

Fig. 11. Overall structure of the wind farm model

3. Test system

The test system to evaluate the interaction of the wind farm with the power system is shown in Fig. 12 as a single-line diagram. Such a system features a substation, represented by a Thevenin equivalent with a short circuit power of 100MVA, which feeds a transmission network operating at 132kV/50Hz.

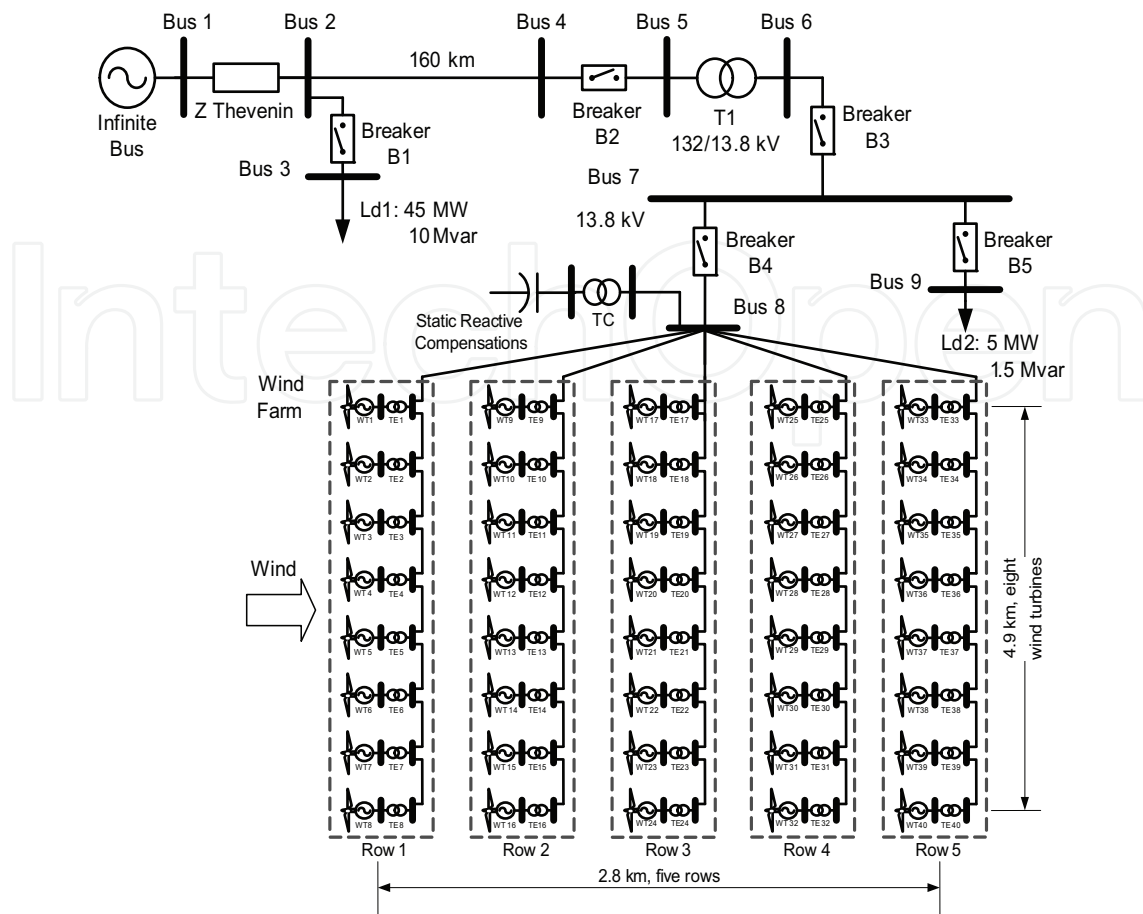

Fig. 12. Test system

Sets of loads are connected to bus 3 (Ld1: 45MW, 10Mvar) and at bus 9 (Ld2: 5MW, 1.5Mvar). A 160km transmission line links, through a 132/13.8kV transformer, the load Ld2 and the wind farm to the substation. The wind farm consists of five rows with eight wind turbines each. The distance between two neighbour turbines and between two consecutive rows is 700m. The wind turbines use a fixed-speed system; and their power curve is shown in Fig. 7. The rated power of each wind turbine is 1.5MW. Therefore, the forty-turbine wind farm has 60MW rated power. Each wind turbine is connected to the grid through an induction generator with squirrel-cage rotor. The demand of reactive power from the wind farm is supplied by capacitors so as to reach a close-to-one power factor. The capacitor banks feature five sections, one per each turbine row. Now, for simplicity in the figure the sections are represented by a single capacitor.

4. Simulation results

4.1 Wind speed and wind farm

This section shows the main results of the models described, mainly of the wind speed model and wind farm model. Fig. 13 shows a profile of wind speed, generated using the model of Fig. 2. Chosen parameters in the algorithm are: $L = 200\text{m}$, $k_{\sigma,v} = 0.15$ with a sampling period of $T = 1\text{s}$. The wind model is applied with three mean values for wind speed, $\bar{v}_1 = 4\text{m/s}$, $\bar{v}_2 = 10\text{m/s}$, and $\bar{v}_3 = 16\text{m/s}$, and for a time period of 10min. Fig. 13 shows the increase of fluctuation amplitudes for growing mean wind speed.

A mean wind speed of 10m/s was chosen for showing the simulation results of the wind farm model. This wind profile is regarded the impinging wind on the first row. Fig. 14 shows the equivalent wind speed for each row of wind turbines. When comparing the wind speed $\bar{v}_2 = 10\text{m/s}$ of Fig. 13 with the wind speed of the row 1 of Fig. 14, it can be noted a reduction of wind turbulence in the wind speed of row 1 of Fig. 14. This reflects the non-coincidence of power fluctuations in all turbines of the same row. Moreover, in Fig. 14, a reduction is noted on the wind speed for all rows, and a time delay of wind speed fluctuations among rows.

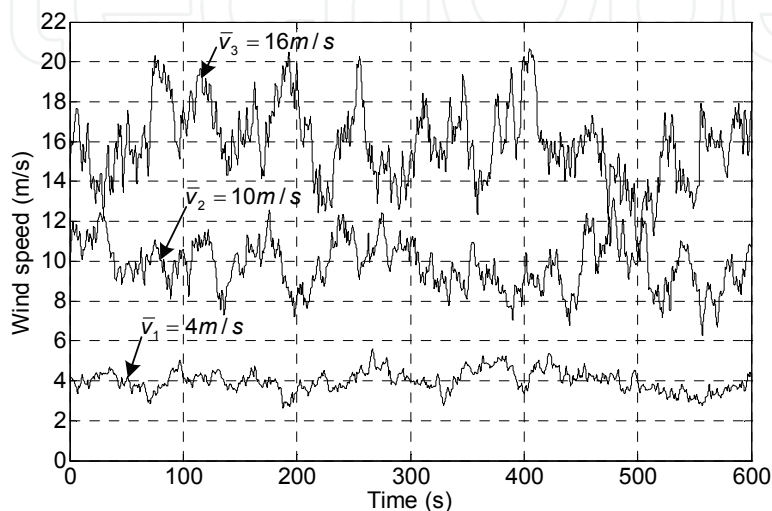

Fig. 13. Profiles of the generated wind speed, for different values of mean speed: $\bar{v}_1 = 4\text{m/s}$, $\bar{v}_2 = 10\text{m/s}$, and $\bar{v}_3 = 16\text{m/s}$

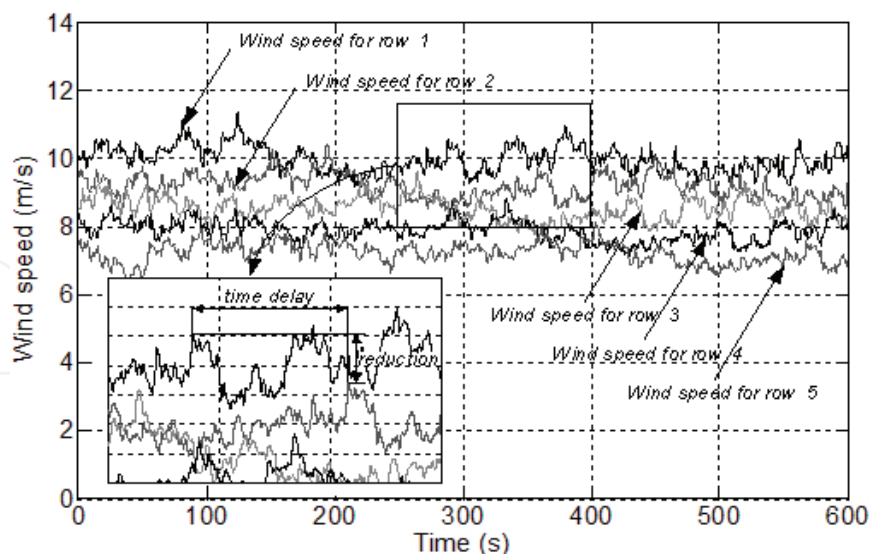

Fig. 14. Equivalent wind speed for each row of the wind farm

Fig. 15 shows the active power generated by each row and the total active power delivered by the wind farm. Fig. 16 shows the reactive power produced by the wind farm and compensated by a capacitors bank for a mean wind speed of 10m/s. In Fig. 15, an important fluctuation of the active power delivered by the wind farm can be noted. This fluctuation of active power is

transmitted into the grid via the transmission line, which may cause problems not only at the connection point of the wind farm but also at other points of the system.

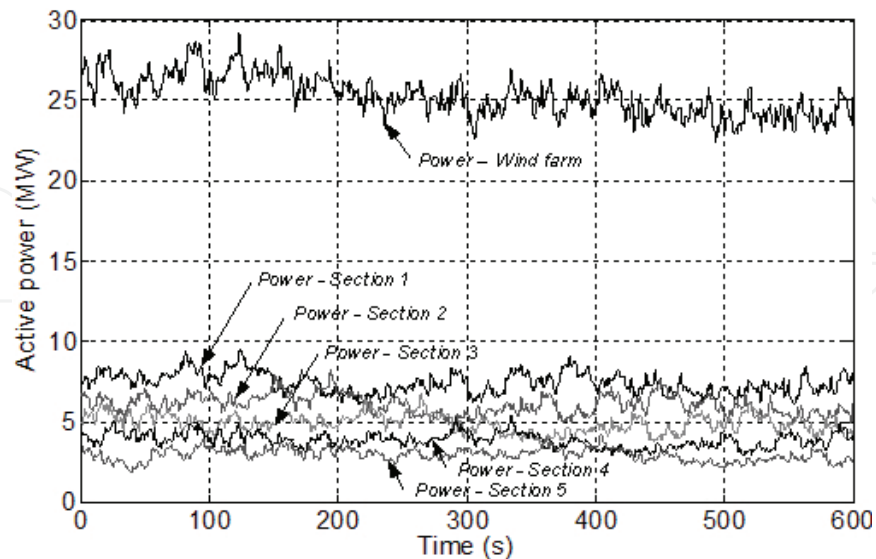

Fig. 15. Active power generated by the wind farm and by each row of wind turbines

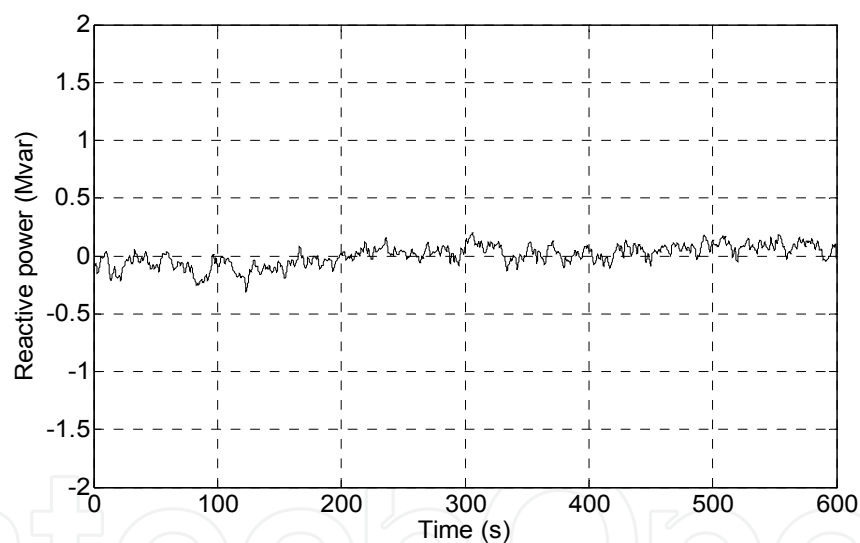

Fig. 16. Reactive power generated by the wind farm and the capacitors bank

4.2 Impacts of wind power on the power system

This section studies the impacts of the wind farm on the power system of Fig. 12. For this, case studies that represent different operating states of the wind farm are simulated. The behaviour of the voltage is observed at bus bars of the wind farm and at loads. First, an analysis is made on the wind farm operating with two mean wind speeds. Finally, the effects are studied when contingencies arise in the farm.

4.2.1 Wind farm operating with mean wind speeds of 10 m/s and 6 m/s

Two cases are simulated with the wind farm operating with all wind turbines connected. One of them has a mean wind speed of 10m/s and the other has mean wind speed of 6m/s.

In the first case, the power through the line flows from the wind farm to the substation. With a value of 10m/s of mean wind speed, the wind farm injects into the grid both the active and reactive power as shown in Fig. 15 and in Fig. 16, respectively. Since the load is constant; the same power fluctuations injected by the wind farm are transmitted along the transmission line to the rest of the system. In the second case, with a mean wind speed of 6m/s, the power through the line flows from the substation to the wind farm bus; because the power injected by the wind farm cannot supply the entire demand at bus 7. Fig. 17 shows both the active and the reactive power injected by the wind farm, with a mean operating wind speed of 6m/s. In this case, the capacitors bank compensates the reactive power for a mean wind speed of 6m/s, rendering the system with a null average reactive power.

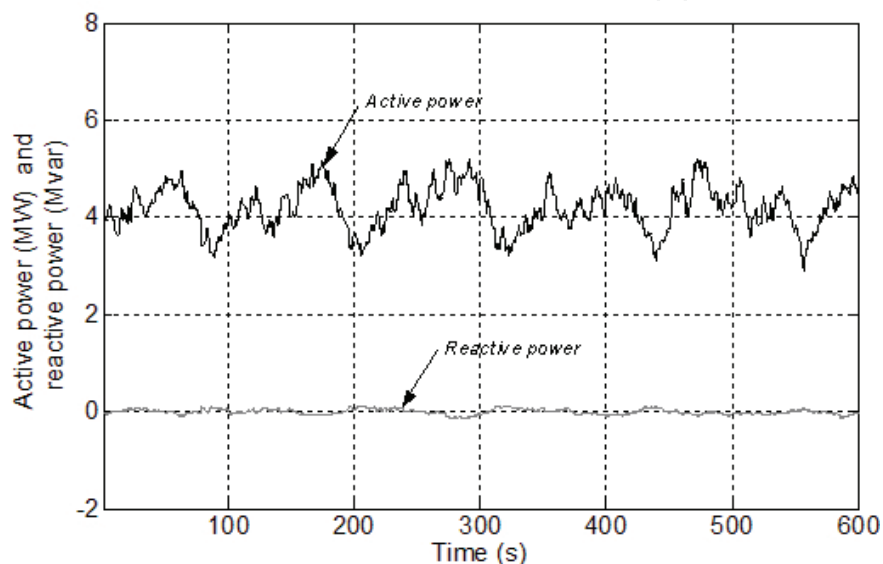

Fig. 17. Active and reactive power injected by the wind farm with a mean wind speed of 6m/s

As mentioned above, the power injections of the wind farm are transmitted to the entire system through the transmission line. These power injections may cause certain problems at different points in the grid. This is most likely to happen in a weak system as the one discussed in this chapter. Fig. 18 and Fig. 19 show the voltage at two buses of the system: at bus 7 (13.8kV), where the wind farm is connected, and where the load is present; and at bus 2 (132kV), at the other end of the transmission line, where load is also present. Figs. 18 and 19 show, respectively, the voltage for the wind farm operating with a mean wind speed of 10m/s and 6m/s.

The figures show that both simulated cases experience marked voltage fluctuations, even when the farm operates with a mean wind speed of 6 m/s and injecting relatively little power to the grid. Besides, for both cases, these voltage fluctuations take place not only at the connection point of the wind farm but also at bus 2 on the other end of the line. The reason for this is that it is a relatively weak system and that it has a low short circuit power at bus 2.

Finally, when the wind farm operates with a mean wind speed of 10m/s, it may be noted that the voltage is above the desired value of 1 pu at bus 7. This is mainly due to the injection of a large power flow at a point where the load is relatively small.

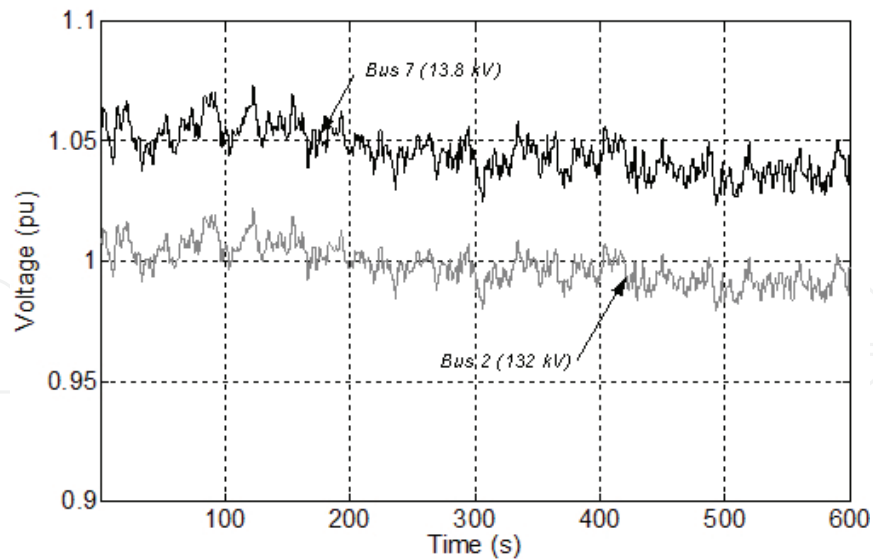

Fig. 18. Voltage at bus 2 and bus 7 for the wind farm operating with a mean wind speed of 10m/s

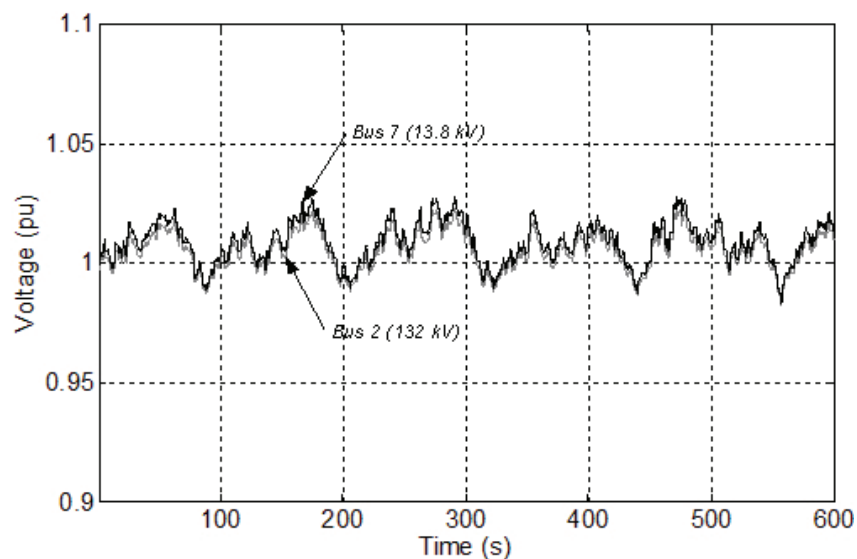

Fig. 19. Voltage at bus 2 and bus 7 for the wind farm operating with a mean wind speed of 6m/s

4.2.2 Contingencies in the wind farm

This section discusses two cases for a wind farm system introducing contingencies into the grid. In both cases simulated, a mean wind speed of 10m/s is used.

The first case simulates the gradual connection of eight wind turbines with their respective capacitors banks. At first, it is considered that the wind farm is operating with four of the five rows of Fig. 12. Then, the fifth row is added by gradually connecting by pairs its eight turbines at: $t = 150s$, $t = 250s$, $t = 350s$ and $t = 450s$. When connecting each pair, the corresponding capacitors for reactive power compensation are gradually connected as well; in four steps every 15s. Fig. 20 shows, respectively, the active and reactive power injected to the grid.

In the second case, a fault is simulated for one turbines row which causes the disconnection of the row's eight wind turbines. First, a normal operation is considered, i.e., the wind farm with the forty wind turbines connected. In $t = 30\text{s}$ a fault is produced (a short circuit between one phase and ground) in the line that links row 1 with bus 8. Then, at $t = 30.1\text{s}$, the fault is cleared by disconnecting this row of eight turbines from the system. Fig. 21 shows the active and reactive power injected by the wind farm in such a case. It can be seen that the reactive power has a mean value around zero before and after the fault occurrence. This is explained by the fact that, when row 1 is disconnected, the capacitors bank that compensates such row gets disconnected as well.

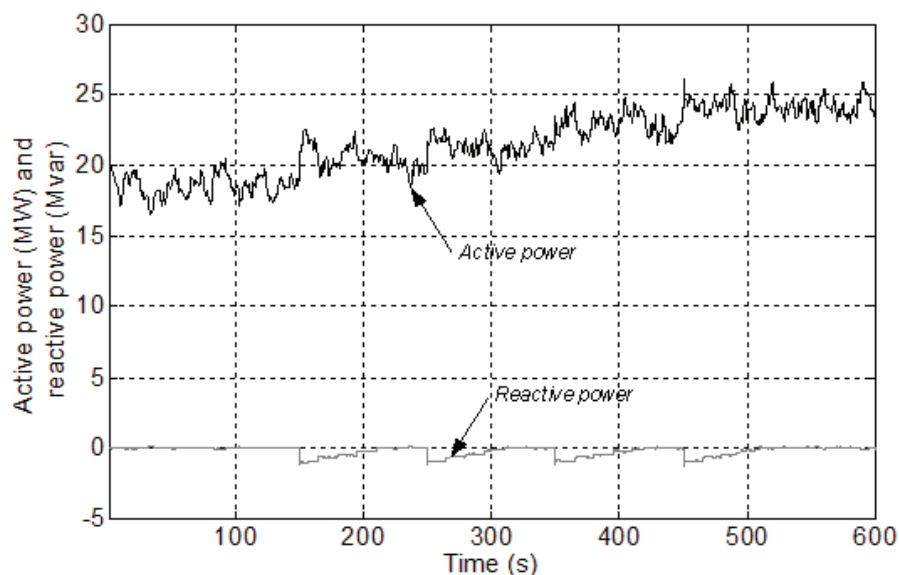

Fig. 20. Active and reactive power injected by the wind farm when the wind turbines are connected

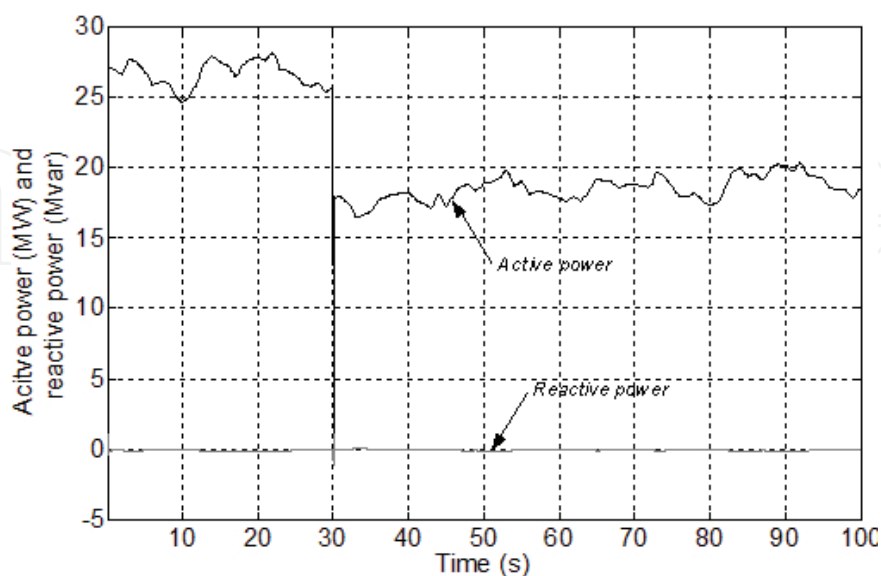

Fig. 21. Active and reactive power injected by the wind farm when a fault inside the farm occurs

These fluctuations of active and reactive power are passed into the system, causing voltage fluctuations at the various buses. Fig. 22 and Fig. 23 show the voltage at bus 7 and at bus 2 for both simulations. In the first case (Fig. 22), voltage fluctuations caused by wind turbulence are noted. In addition, a voltage increase due to the connection of wind turbines is also noted.

In the second case (Fig. 23), it can be noted that when the fault occurs, the voltage at bus 2 and bus 7 falls sharply to values near zero. After clearing the fault and disconnecting the eight wind turbines of row 1, the voltage at both buses remains with lower value than the one existing before the fault arose.

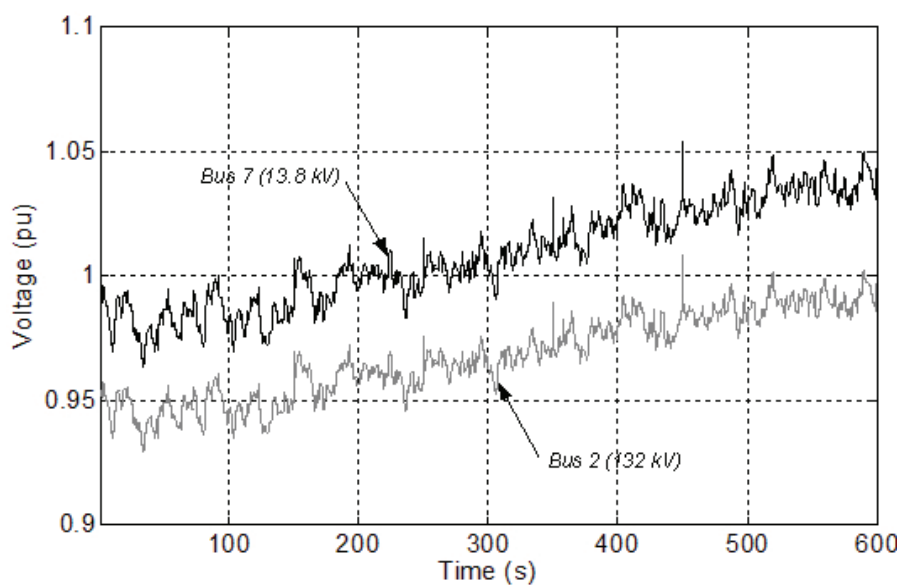

Fig. 22. Voltage at bus 2 and bus 7 for connection of wind turbines

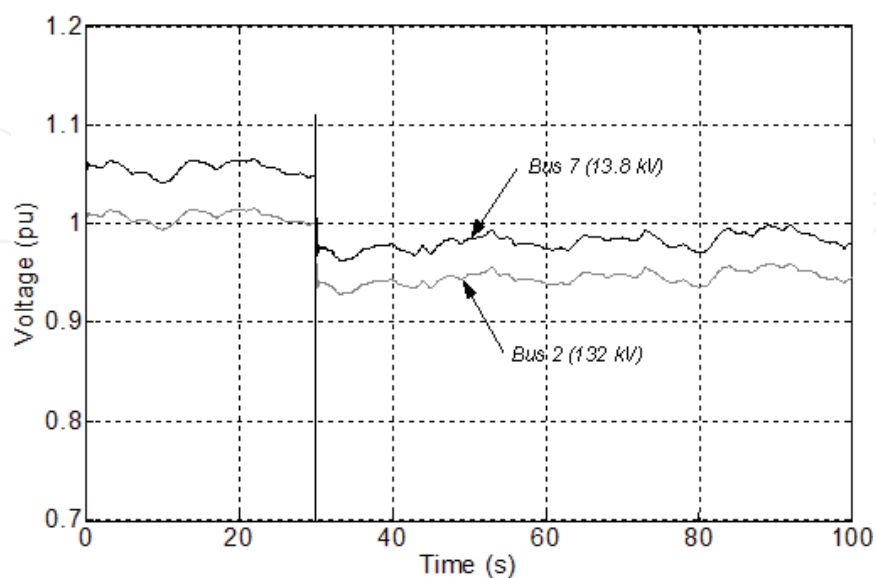

Fig. 23. Voltage at bus 2 and bus 7 for a fault inside the wind farm

Finally, and taking into account all the cases analyzed, it can be concluded that the power fluctuations injected by the wind farm with fixed-speed wind turbines cause significant voltage fluctuations. It was observed that, for this weak power system here studied, these voltage fluctuations take place not only at the point of connection of the wind farm but also at other buses of the system. These voltage fluctuations are mainly caused by wind turbulence and, obviously, are increased when contingencies arise in the system, such as when connecting the turbines or when faults occur. Therefore, the insertion of a wind farm with fix-speed wind turbines into a weak power system introduces significant problems as regards the quality of the voltage levels delivered to the consumers. Voltages with so poor quality could cause malfunction of equipments and significant losses, depending on the type of consumer load.

5. Conclusions

In this chapter, the model aspects and the impact of wind power onto a weak power system have been described. A wind system model was presented that takes into account factors such as a rapidly varying turbulence component of the wind and the aerodynamic effects associated to the layout of wind turbines throughout the farm. A test system was used and case studies for different instances of wind farm operation were analyzed, aiming at evaluating the interaction of the wind farm with the power system.

The results here obtained have shown that the incorporation of the wind farm with fix-speed wind turbines into a weak power system introduces important problems in the quality of voltage. Therefore, in order to insert the wind farm into a weak power system would call for incorporating additional means and equipment to improve the voltage quality rendered to the costumers. Among the different solutions that could be resorted to, more compensation from local reactive and voltage support devices, such as capacitors, SVCs, etc. should be considered. And for faster voltage fluctuations, synchronous static compensators could be used, such as DSTATCOM devices. Better solutions are obtained if these static compensators incorporate devices for energy storage and fast response, such as flywheels, SMES systems or supercapacitors. These devices with storage capacity not only allow controlling the reactive power but also the active power which can make the wind farm deliver a smoother power output to the grid.

6. References

- Ackermann, T. (2005). *Wind Power in Power systems*. John Wiley & Sons, Ltd, ISBN 0-470-85508-8 (HB), England.
- Chen, Z. & Spooner, E. (2001). Grid Power Quality with Variable Speed Wind Turbines. *IEEE Transactions on Energy Conversion*, vol. 16, N° 2, pp 148-154, June 2001.
- Delmerico, R.W.; Miller, N.; Price, W.W. & Sanchez-Gasca, J.J. (2003). Dynamic Modelling of GE 1.5 and 3.6 MW Wind Turbine-Generators for Stability Simulations, *IEEE Power Engineering Society PES General Meeting*, 13-17, July 2003, Toronto, Canada.
- Frandsen, S.; Barthelmie, R.; Pryor, S.; Rathmann, O.; Larsen, S. & Højstrup, J. (2004). Analytical Modeling of Wind Speed Deficit in Large Offshore Wind Farms.

- European Wind Energy Conference & Exhibition*, pp. 6-11, London, Nov. 2004, England.
- Hassan, U. & Sykes, D.M. (1985). Wind structure and statistics. *Wind Energy Conversion Systems*, Ch. 2. Prentice Hall, New York.
- Jenkins, N.; Allan, R.; Crossley, P.; Kirschen, D. & Strbac, G. (2000). *Embedded Generation*, The Institution of Electrical Engineers, ISBN 978-0-85296-774-4, England.
- Leithhead, W.E.; De la Salle, S. & Reardon D. (1991). Role and Objectives of Control for Wind Turbines. *IEE Proceedings*, vol. 138, Pt.C, N° 2, pp.135-148.
- Mohod, S.W. & Aware, M.V. (2008). Power Quality Issues & It's Mitigation Technique in Wind Energy Generation. *IEEE Harmonics and Quality of Power*, September 2008.
- Nichita, C.; Luca, D.; Dakyo, B. & Ceanga, E. (2002). Large band simulation of the wind speed for real time wind turbine simulators. *IEEE Transactions on Energy Conversion*, vol. 17, N° 4, 2002.
- Pálsson, M.; Toftevaag, T.; Uhlen, K.; Norheim, I.; Warland, L. & Tande, J. O. G. (2004). Wind Farm Modeling for Network Analysis - Simulation and Validation. *European Wind Energy Conference & Exhibition*, pp. 134-138, Nov. 2004, England.
- Pavinatto, E. (2005). Ferramenta para Auxílio à Análise de Viabilidade Técnica da Conexão de Parques Eólicos à Rede Elétrica. *Tese de Mestrado, COPPE/UFRJ*, Rio de Janeiro, Brasil, 2005.
- Pöller, M. & Aechilles, S. (2003). Aggregated Wind Park Models for Analysing Power System Dynamics. *4th International Workshop on Large Scale Integration of Wind Power an Networks for Offshore Wind-Farms*, Billund, Denmark.
- Rosas, P. (2003). Dynamic Influences of Wind Power on the Power System. *PhD thesis, Ørsted•DTU, Section of Electric Power Engineering*, March 2003.
- Siegfried Heier. (1998). *Grid Integration of Wind Energy Conversion Systems*, John Wiley & Sons Ltd, 1998, ISBN 0-471-97143-X, New York, USA.
- Slotweg, J.G. & Kling, W.L. (2003). Is the Answer Blowing in the Wind? *IEEE Power & Energy magazine*, pp 26-33, November/December 2003.
- Smith, J.C.; Milligan, M.R. & DeMeo, E.A. (2007). Utility Wind Integration and Operating Impact State of the Art. *IEEE Transaction on Power System*, vol. 32, N°3, pp.900-907, August 2007.
- Soens, J.; Driesen, J. & Belmans, R. (2005). Equivalent transfer function for a variable speed wind turbine in power system dynamic simulations. *International Journal of Distributed Energy Resources*, vol. 1 num. 2, pp. 111-133, Apr.-Jun. 2005.
- Sørensen, P.; Cutululis, N.A.; Viguera - Rodriguez, A.; Jensen, L.; Hjerrild, J.; Donovan M.H. & Madsen, H. (2007). Power Fluctuations from Large Wind Farms, *IEEE Trans on Power Systems*, vol. 22, N° 3, 958-965, 2007.
- Suvire, G. O. & Mercado, P. E. (2006). Impacts and alternatives to increase the penetration of wind power generation in power systems. *X SEPOPE (X Symposium of specialists in electric operational and expansion planning)*, Florianopolis, May 2006, Brasil.

Welfonder, E.; Neifer, R. & Spanner, M. (1997). Development and experimental identification of dynamic models for wind turbines. *Control Eng. Practice*, vol. 5, N° 1, pp. 63-73, 1997.

IntechOpen

IntechOpen



Dynamic Modelling

Edited by Alisson V. Brito

ISBN 978-953-7619-68-8

Hard cover, 290 pages

Publisher InTech

Published online 01, January, 2010

Published in print edition January, 2010

When talking about modelling it is natural to talk about simulation. Simulation is the imitation of the operation of a real-world process or systems over time. The objective is to generate a history of the model and the observation of that history helps us understand how the real-world system works, not necessarily involving the real-world into this process. A system (or process) model takes the form of a set of assumptions concerning its operation. In a model mathematical and logical assumptions are considered, and entities and their relationship are delimited. The objective of a model – and its respective simulation – is to answer a vast number of “what-if” questions. Some questions answered in this book are: What if the power distribution system does not work as expected? What if the produced ships were not able to transport all the demanded containers through the Yangtze River in China? And, what if an installed wind farm does not produce the expected amount of energy? Answering these questions without a dynamic simulation model could be extremely expensive or even impossible in some cases and this book aims to present possible solutions to these problems.

How to reference

In order to correctly reference this scholarly work, feel free to copy and paste the following:

Gastón Orlando Suvire and Pedro Enrique Mercado (2010). Dynamic Modelling of a Wind Farm and Analysis of Its Impact on a Weak Power System, Dynamic Modelling, Alisson V. Brito (Ed.), ISBN: 978-953-7619-68-8, InTech, Available from: <http://www.intechopen.com/books/dynamic-modelling/dynamic-modelling-of-a-wind-farm-and-analysis-of-its-impact-on-a-weak-power-system>

INTECH
open science | open minds

InTech Europe

University Campus STeP Ri
Slavka Krautzeka 83/A
51000 Rijeka, Croatia
Phone: +385 (51) 770 447
Fax: +385 (51) 686 166
www.intechopen.com

InTech China

Unit 405, Office Block, Hotel Equatorial Shanghai
No.65, Yan An Road (West), Shanghai, 200040, China
中国上海市延安西路65号上海国际贵都大饭店办公楼405单元
Phone: +86-21-62489820
Fax: +86-21-62489821

© 2010 The Author(s). Licensee IntechOpen. This chapter is distributed under the terms of the [Creative Commons Attribution-NonCommercial-ShareAlike-3.0 License](#), which permits use, distribution and reproduction for non-commercial purposes, provided the original is properly cited and derivative works building on this content are distributed under the same license.

IntechOpen

IntechOpen