

We are IntechOpen, the world's leading publisher of Open Access books Built by scientists, for scientists

4,800

Open access books available

122,000

International authors and editors

135M

Downloads

Our authors are among the

154

Countries delivered to

TOP 1%

most cited scientists

12.2%

Contributors from top 500 universities



WEB OF SCIENCE™

Selection of our books indexed in the Book Citation Index
in Web of Science™ Core Collection (BKCI)

Interested in publishing with us?
Contact book.department@intechopen.com

Numbers displayed above are based on latest data collected.

For more information visit www.intechopen.com



Modelling and Design of a Mechatronic Actuator Chain Application to a Motorized Tailgate

K. Ejjabraoui¹, C. Larouci¹, P. Lefranc², C. Marchand³,
B. Barbedette¹ and P. Cuvelier¹

¹*Ecole Supérieure des Techniques Aéronautiques et de Construction Automobile,*

²*SUPELEC Energie,*

³*Laboratoire de Génie Electrique de Paris
France*

1. Introduction

Recently, several mechatronic systems are integrated in automotive applications (motorized tailgate, electrical seats...) (Su and al., 2005) (R. Juchem and B.Knorr, 2003) (Mutoh and al., 2005) (Joshi and al., 2008). The modelling of these applications needs to take into account multi-physic aspects (mechanical, electrical, control ...) in order to consider the coupling effects between these domains. However, the existing tools are not well adapted to this multi-physic modelling because they are rather mono-field, less libraries are available, modelling levels (0D-1D and 2D-3D) are generally not possible in the same tool, the mechanical and electrical aspects are not modelled with the same accuracy, high difficulties to manage multi-time scale.... The close association of some potential existing tools (G. Remy and al., 2009) appears most favorable to achieve the needed mechatronic environment. The aim of this work is to evaluate the performances of MATLAB/SIMULINK/SimPowerSys tool through a motorized tailgate application.

Firstly, a description of the studied mechatronic application will be given. Secondly, different models are developed for each part (battery, dc-dc converter, electrical machine, gearbox, ball-screw and mechanical joints). In this context, dynamic, friction and losses models will be presented. Then, they are implemented and simulated using MATLAB/SIMULINK/SimPowerSys tool. Simulation results in transition and steady states will be discussed. Finally, the performances of this tool will be listed and its mains advantages and disadvantages will be presented.

2. The studied application: motorized tailgate

The figure 1 presents a synopsis of the motorized tailgate application. It's a system providing an autonomous opening and closing of some recent car trunk which uses two electromechanical actuators. In this system, three main parts can be distinguished: electrical part (battery, LC filter, dc-dc converter, and electromechanical actuator), mechanical part (gearbox, mechanical actuator with ball-screw, car tailgate) and control part (master-slave controller with position and current loops).

Source: Dynamic Modelling, Book edited by: Alisson V. Brito,
ISBN 978-953-7619-68-8, pp. 290, January 2010, INTECH, Croatia, downloaded from SCIYO.COM

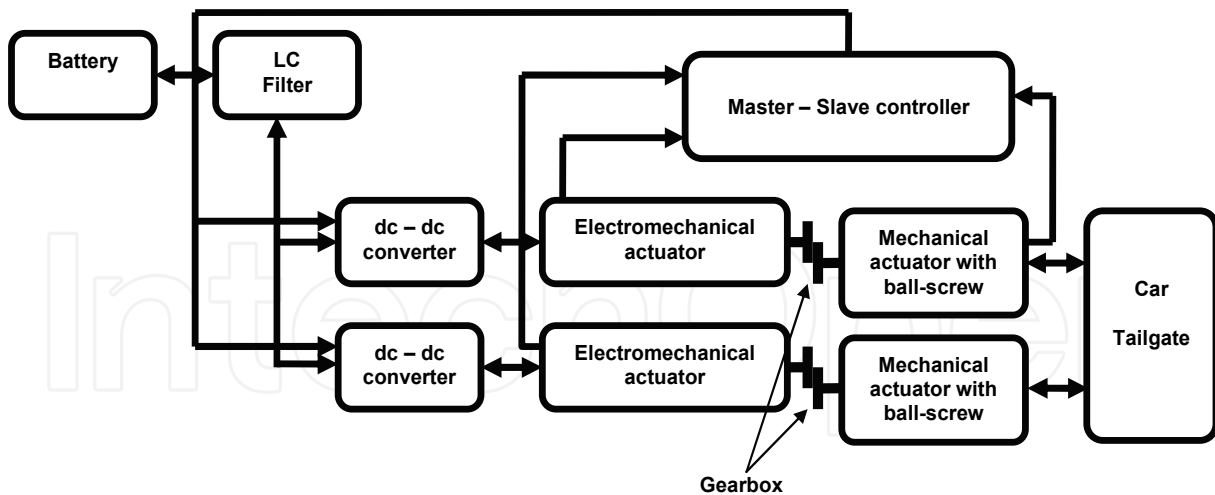

Fig. 1. Synopsis of the motorized tailgate

2.1 Description of the electrical part

The principle of the electrical part for the studied application is given by the figure 2. In fact, two electromechanical actuators (MCC 1 and MCC 2) are used to control two mechanical actuators with ball-screw. These two electromechanical actuators are associated to two dc-dc converters which are connected to a battery. To eliminate the disturbances induced by the switching frequency of the semiconductors, a LC filter is used.

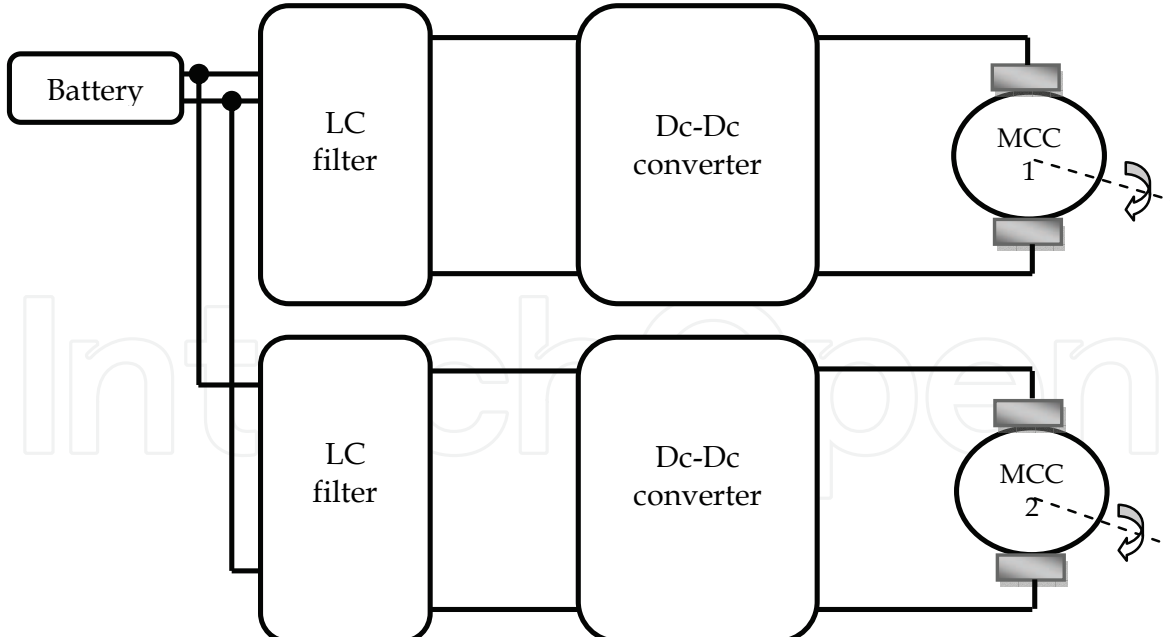

Fig. 2. The principle of the electrical part

2.1.1 Battery

The battery is modelled by a DC voltage source with a resistance representing the losses in the connections between the battery and the LC filter (figure 3).

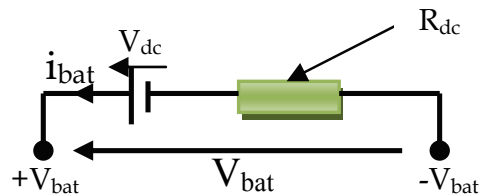

Fig. 3. Simplified model of the battery

2.1.2 LC filter

To eliminate the disturbances induced by the switching frequency of the semi-conductors, a LC filter (figure 4).

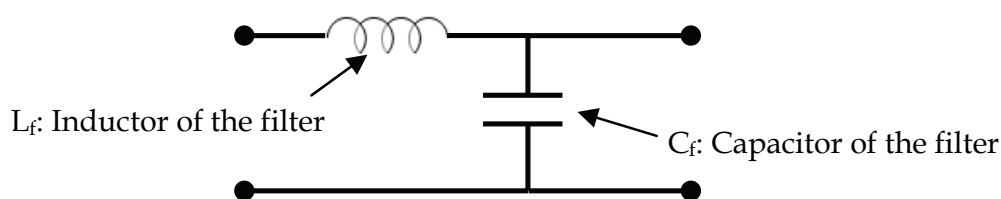

Fig. 4. The input filter scheme

2.1.3 DC-DC converter

The dc-dc converter is used to adapt the energetic exchange between two continuous sources. According to the specifications of the mechanical load (reversibility in torque and in speed) and of the battery (dc voltage source), the chosen converter for the studied application is a four-quadrant dc-dc converter which is composed of four controlled switches and four anti-parallel diodes. The figure 5 shows the architecture of this converter.

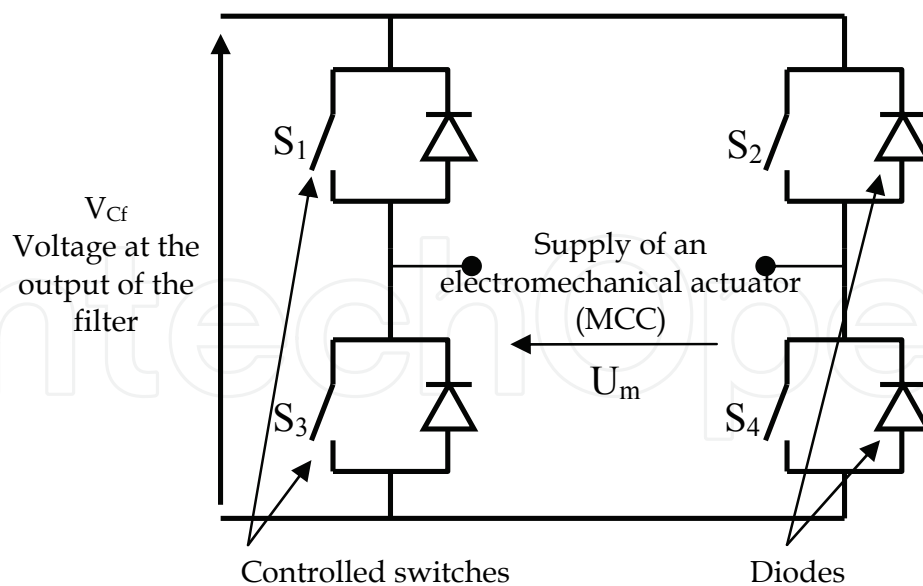

Fig. 5. Architecture of the dc-dc converter

2.1.4 Electromechanical actuator

The electromechanical actuator is used to convert electrical energy to a mechanical energy and reciprocally. It is a dispositive which is reversible in torque (current) and in speed

(voltage) allowing to have two modes of operating: motor mode (transform electrical energy to a mechanical energy) and generator mode (transform mechanical energy to an electrical energy). It is composed of a fixed part (stator) and a mobile part (rotor) as shown in (figure 6.a). The figure 6.b gives the electro-mechanical scheme for this actuator. For the studied application, two electromechanical actuators are used to control two mechanical actuators with a screw-ball through gearboxes.

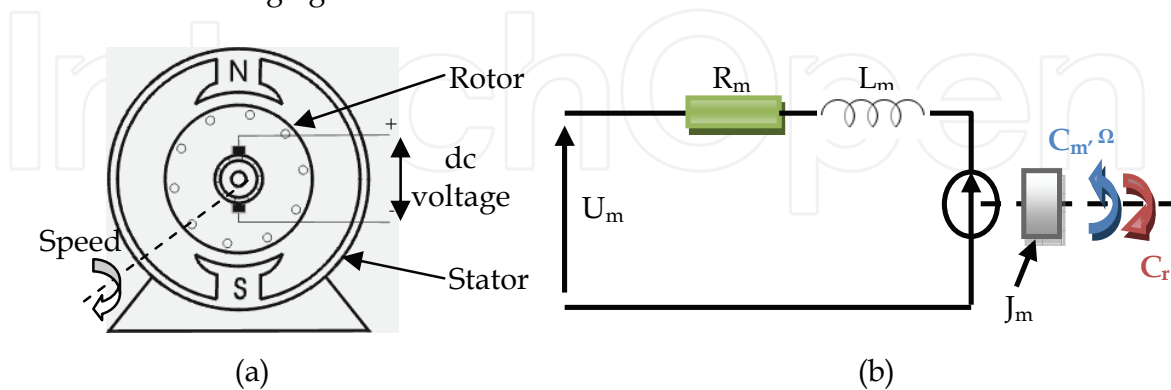

Fig. 6. (a) Physical scheme (b) Electromechanical scheme

U_m is the input voltage of the machine, R_m and L_m are respectively the resistance and the inductance of the armature (stator), C_m is the electromechanical torque of the machine, Ω is the speed angular of the rotor, J_m is the moment of inertia and C_r is the resisting torque due to load and frictions.

2.2 Description of the mechanical part

The mechanical part of the studied application is represented by a mechanical load (car body) which is actuated by two motorized mechanical actuators allowing the autonomous opening and closing of the car tailgate. To adapt the speed between the electrical machine and this mechanical actuator, a gearbox is placed between them.

The kinematics of the tailgate is ensured by hinges that we will approximate to a pivot link between the car body and the tailgate on its upper part and ball joint at lower part of the mechanical actuator.

2.2.1 Car tailgate

The car tailgate is represented by a masse (M) which is centred approximately in the centre of masse of the tailgate in closed position. The tailgate is considered a flexible body by taking into account its first torsion mode. The figure 7 shows the placement of the tailgate masse compared to two mechanical actuators and the car body in the plan (XY).

2.2.2 Motorized mechanical actuator

The motorized mechanical actuators are composed of a body and a stem. A sliding pivot link allows connect these two solids. The extremities of each actuator are connected to the body and the tailgate with a ball joint. During our study, the body of the mechanical actuator is imposed by the industrial partners and it is composed of the electrometrical actuator (DC motor), the gearbox, the spring and the ball screw. The figure 8 presents the composition of the mechanical actuators.

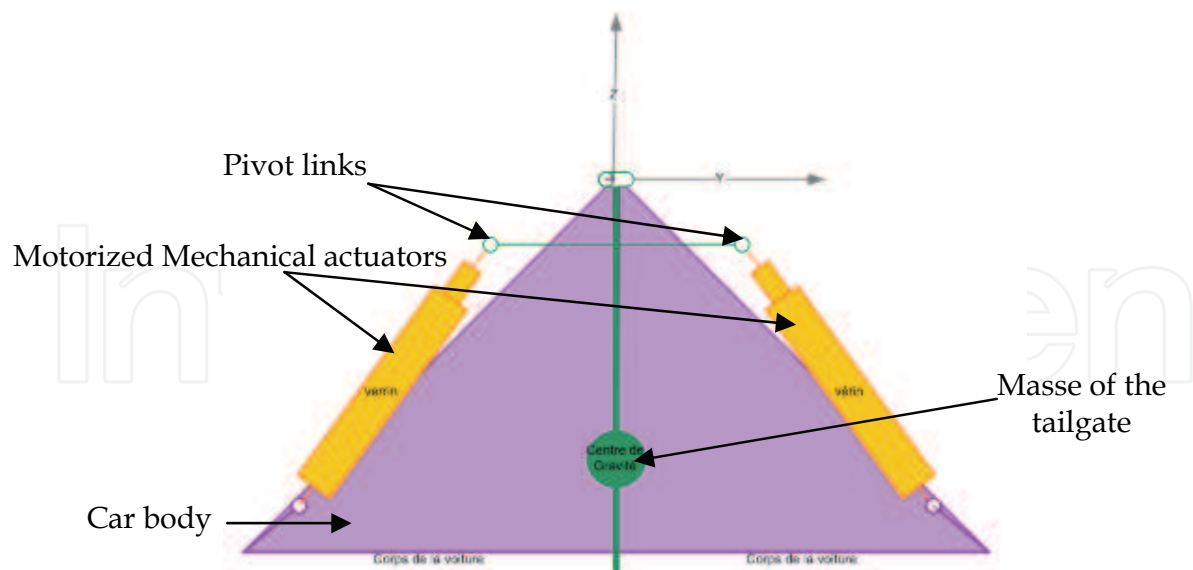

Fig. 7. Placement of the tailgate masse

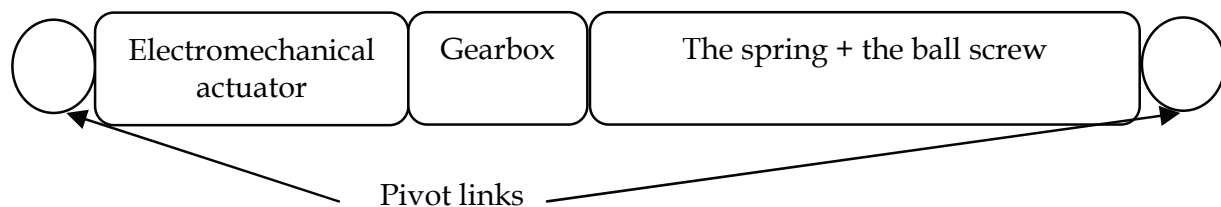

Fig. 8. Composition of the mechanical actuators

2.3 Description of the control part

To ensure the desired performances at the system outputs, a controller is adapted (master – slave controller) and associated to two dc-dc converters. The control strategy is based on a cascade correction. To perform this control aspect, the right mechanical actuator (figure 7) is called slave actuator and the left one is called the master actuator. The primary control (extern loop) is based on the position of the tailgate and the secondary control (intern loop) based on the induced current in the electrical machine. In the intern control loop, the reference current of the slave actuator is measured in the master actuator. For the extern loop, the reference of the tailgate angular position is obtained by integration of the tailgate angular velocity given in figure 9.

The figure 10 shows the principle of the cascade correction adopted for our application.

Com1 and Com2 present the control signals of converters 1 and 2 associated to the master and slave actuators.

A PI corrector is used to the intern loop (current loop) of each machine, while a PID corrector is used for the extern loop (position loop).

3. Modelling

The objective of modeling is to propose models to simulate the motorized tailgate on an open-close cycle. Physical equations governing the operation of the motorized tailgate are

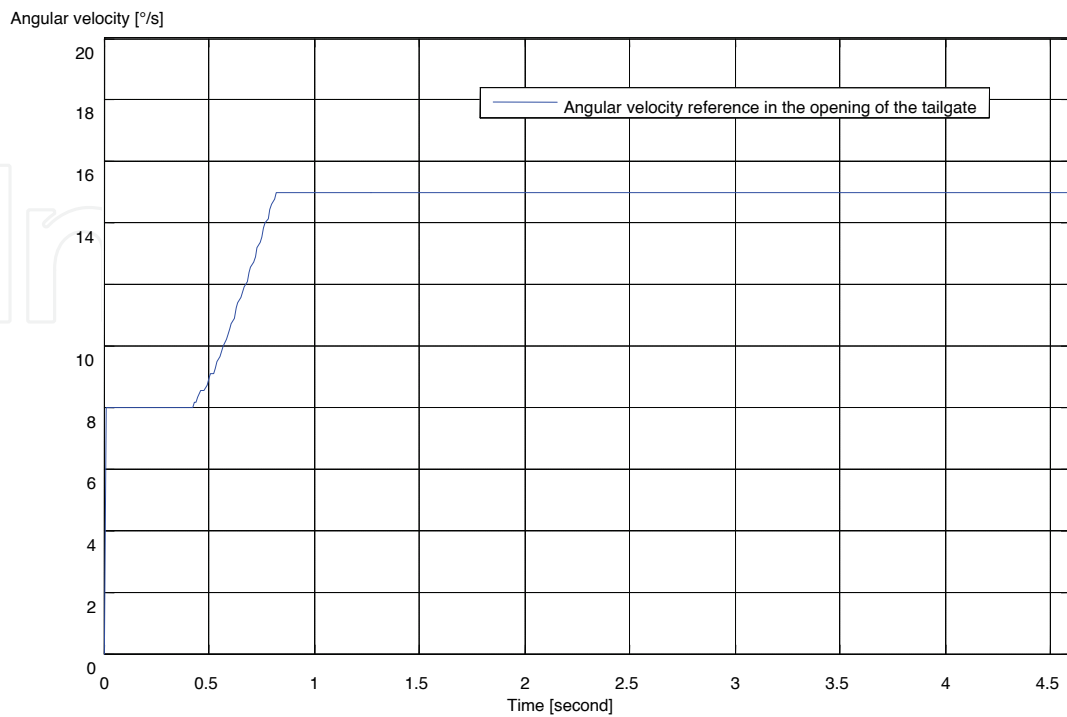

Fig. 9. Angular velocity profile in the opening phase

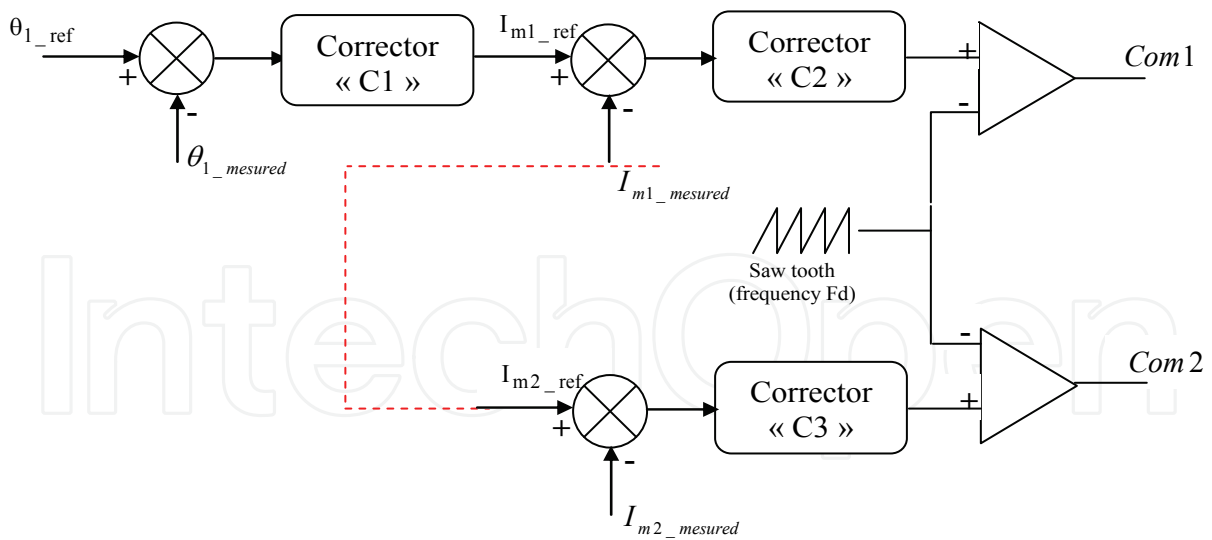

Fig. 10. the principle of the cascade correction

developed. In the electrical part, the electromechanical actuator is modeled by its electrical and mechanical equations. The battery and the LC filter are modeled respectively as shown in figures 3 and 4. In the mechanical part, the motorized tailgate car operation is modeled by differential equations resulting from the application of the kinetic moment theorem.

3.1 Models related to the mechanical part (car tailgate, mechanical actuator, and gearbox)

In order to determine the angular position according to the force developed by the mechanical actuator, we apply the theorem of the kinetic moment to each actuator with the tailgate. We obtain the system of differential equations translating the equations of motion of the tailgate:

$$\left(\frac{J}{2} + \frac{m}{2} R_{XZ}^2\right) \ddot{\theta}_g = R_{XZ} \frac{m}{2} g \cos \gamma_h - r_{XZ} F_{Vg} \cos \gamma_g + K(\theta_g - \theta_d) \quad (1)$$

$$\left(\frac{J}{2} + \frac{m}{2} R_{XZ}^2\right) \ddot{\theta}_d = R_{XZ} \frac{m}{2} g \cos \gamma_h - r_{XZ} F_{Vd} \cos \gamma_d + K(\theta_d - \theta_g) \quad (2)$$

$$\begin{cases} \gamma_{h_d} = \theta_0 + \theta_d - \gamma_0 - \gamma_{ref} \\ \gamma_{h_g} = \theta_0 + \theta_g - \gamma_0 - \gamma_{ref} \end{cases} \quad (3)$$

$$\begin{cases} \gamma_g = \sin^{-1} \left(\frac{D_{XZ}^2 - L_{gXZ}^2 - r_{XZ}^2}{-2L_{gXZ} \cdot r_{XZ}} \right) \\ \gamma_d = \sin^{-1} \left(\frac{D_{XZ}^2 - L_{dXZ}^2 - r_{XZ}^2}{-2L_{dXZ} \cdot r_{XZ}} \right) \end{cases} \quad (4)$$

J is the inertia of the tailgate

m is the masse of the tailgate

R_{XZ} is the distance between the center of the pivot link and the center of mass in the XZ plane.

g is the gravity

D_{XZ} is the distance between (O: center) and (B_d : attachment point between the left mechanical actuator and the car body or B_g : attachment point between the right mechanical actuator left and the car body) projected in the XZ plane

L_d is the length of the left mechanical actuator projected in the XZ plane

L_g is the length of the right mechanical actuator projected in the XZ plane

r_{XZ} is the distance between (O : center) and (C_d : attachment point between the left mechanical actuator and the tailgate or C_g : attachment point between the right mechanical actuator and the tailgate) projected in the XZ plane

θ_0 is the Angle projected in the XZ plane between axes (OB) and (OC) in the closed position

θ_d is the left angle opening of the tailgate

θ_g is the right angle opening of the tailgate

F_{Vd} is the force developed by the left mechanical actuator

F_{Vg} is the force developed by the right mechanical actuator

K is is the torsion coefficient of the tailgate

γ_h is the angle projected in the XZ plane between axes (OX) and (OG)

γ_0 is the angle projected in the XZ plane between axes (OX) and (OB)

γ_{ref} is the Angle projected in the XZ plane between axes (OC) and (OG)

3.2 Models related to the electrical part

In this part, the electro-mechanical actuator is modeled by its electrical, mechanical and coupling equations.

The electrical equation is given according to the operating mode of the machine:

- Motor mode:

$$U_m = k_m \cdot \Omega_m + R_m \cdot I_m + L_m \cdot \frac{dI_m}{dt} \quad (5)$$

- Generator mode:

$$U_m = k_m \cdot \Omega_m - R_m \cdot I_m - L_m \cdot \frac{dI_m}{dt} \quad (6)$$

The mechanical equations with the electromechanical coupling are given by the following formulas:

$$C_{em} - C_{rch} - C_{fv} - C_{fs} = J_{mt} \cdot \frac{d\Omega_m}{dt} \quad (7)$$

$$C_{em} = k_m \cdot I_m$$

C_{em} is the electromechanical torque

C_{rch} is the resisting torque imposed by the load

C_{fv} is the viscous friction torque

C_{fs} is the dry friction torque

J_{mt} is the total moment of inertia

Ω_m is the angular speed of the machine

U_m is the armature voltage

R_m and L_m are respectively the resistance and the inductance of the machine armature

K_m is the electromechanical coupling coefficient

I_m is the current in the machine armature

To have compromise between simulation time and precision of the desired performances for the tailgate, the modeling of the dc-dc converter is performed by using three levels:

- **First level**

The converter is considered as a perfect controlled voltage source $V = (2 \cdot \alpha - 1) \cdot V_{bat}$. This level of modeling allows to quickly validate the system without taking into account the switching of semiconductors.

α : is the duty cycle associated with the converter control

V_{bat} is the voltage of the battery

- **Second level**

In this case, an average model of the converter is used by replacing the switching-on semiconductors during $\alpha \cdot T_d$ (or $(1 - \alpha) \cdot T_d$) by a current source with a value $\alpha \cdot I_m$ (or $(1 - \alpha) \cdot I_m$) and the switching-off semiconductors during $\alpha \cdot T_d$ (or $(1 - \alpha) \cdot T_d$) by a voltage source with a value $\alpha \cdot V_{bus}$ (or $(1 - \alpha) \cdot V_{bus}$).

T_d is the switching period

V_{bus} is the input voltage of the converter

- **Third level**

In this case, the semiconductors of the converter are modeled by controllable switches and anti-parallel diodes. This level allows considering other physical aspects (thermal, CEM...). The figure 11 below summarizes the four possible configurations for this switch and its associated equivalent scheme.

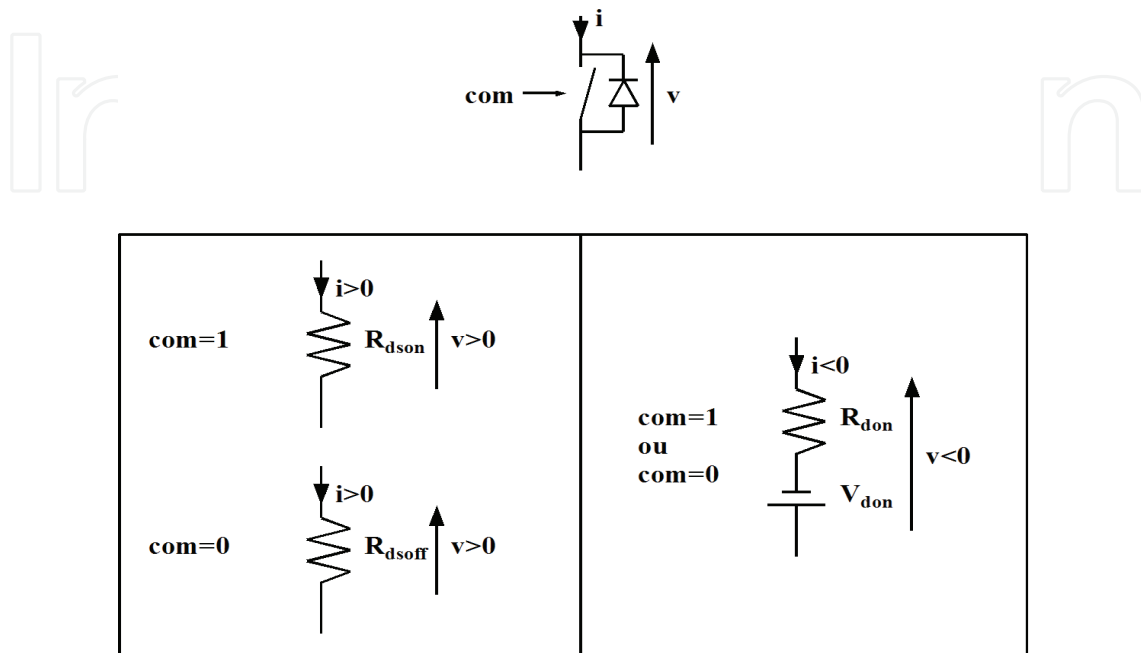

Fig. 11. the principal configurations of the elementary switch

- com : control signal of switch ($com=1$: closed switch, $com=0$: open Switch)
- R_{dson} : resistance of the switch in on state (dynamic resistance of the switch).
- R_{dsoff} : resistance of the switch in off state
- R_{don} : resistance of the diode in the conducting state (dynamic resistance of diode)
- V_{don} : voltage drop of the diode in the conducting state

4. Implementation in MATLAB/SIMULINK/SimPowerSys

Figure 12 shows the principal of the motorized tailgate implementation in MATLAB/SIMULINK/SimPowerSys. In this work, the implementation is based on a combination between diagram blocks (by respecting the bond graph formalism (effort-flow) allowing a-causal modeling and avoid algebraic loops) in simulink and components of available organs in libraries (in matlab-simulink/SimPowerSystems). In our case, the control part is implemented by using transfer function representing the current controller (PI controller) and the position controller (PID controller). The LC filter is implemented by available organs in libraries (inductance and capacitance). The dc-dc converter is modeled by block diagram in the first level and available organs for the second and the third level. In addition, the electromechanical actuator is modeled by transfer functions representing the electrical and the mechanical aspect (formulas 5, 6 and 7) and by considering the electromechanical coupling. According to the differential equations given by the formulas 1, 2, 3 and 4 previously expressed and the other equations related to the ball screw and the tailgate, the tailgate car is implemented by using diagram blocks.

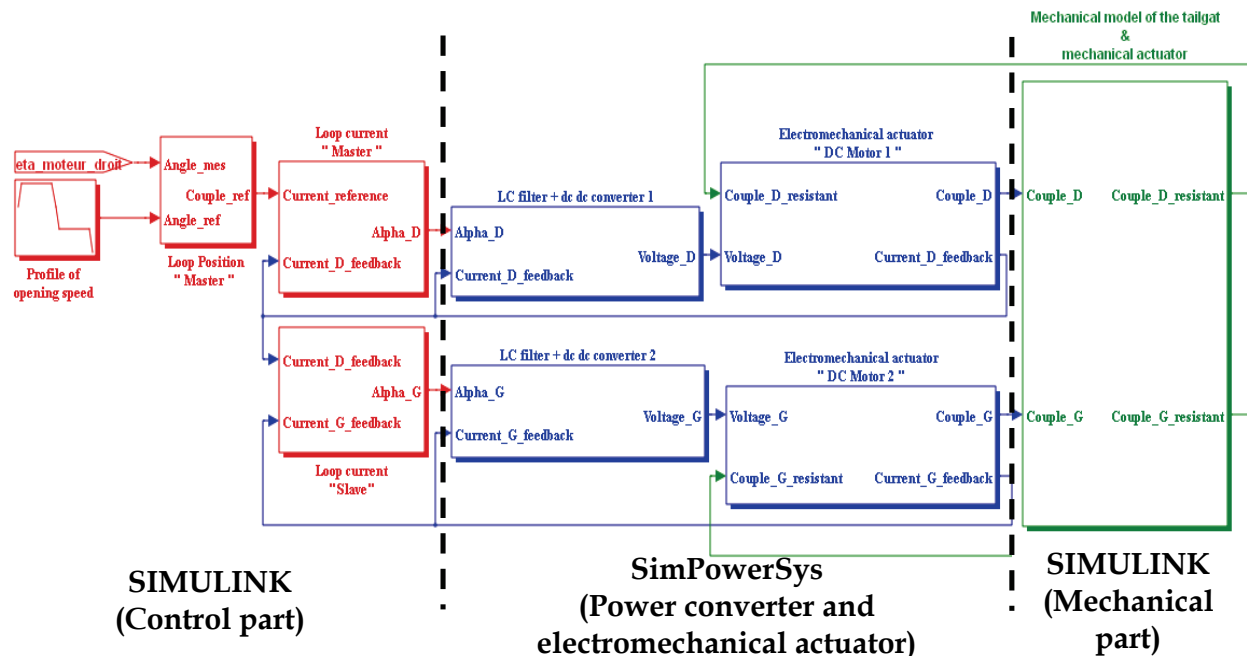

Fig. 12. Implementation in MATLAB / SIMULINK / SimPowerSys

5. Simulation results

The figures 13, 14 and 15 show respectively the tailgate opening angles, the electric machine currents and the mechanical actuator forces related to the master and slave actuators during the opening phase of the tailgate.

To carry out these simulations:

- The initial conditions for the opening angle, the length of the mechanical actuator and the spring force has been taken equal to final values of the closing cycle
- The initial conditions for the closing angle, the length of the mechanical actuator and the spring force has been taken equal to final values of the opening cycle.
- The alimentation of electrical machine (electromechanical actuator) has been stopped at the end of the opening phase and was restored early in the closing phase.
- The integrators of the controllers have been reset in the early closing phase.

Note that the third level of modeling for dc-dc converter is performed in the MATLAB/SIMULINK/SimPowerSys by multi-time scale. In fact, this aspect allows to separate the different time constants in the system which has a mechanical time constant (mechanical load) very slow that the electrical time constant corresponding to the switching frequency of the converter (20 kHz).

As results, the master and slave actuators have the same behaviour. In addition, the opening angle reference is well respected which validate the control aspect (cascade correction) used in this application.

At the beginning of the opening phase, an important torque is delivered by the electrical machine (high absorbed current) to overcome the static frictions. Then, the mechanical actuator ensures the opening with a small contribution of the electrical machine. At the end of the opening phase, the absorbed current increases in order to help the mechanical actuator to establish the tailgate at its final opening position. Note that the ripples observed in the current and a force curves are related to the semi-conductor switching of the dc-dc converter.

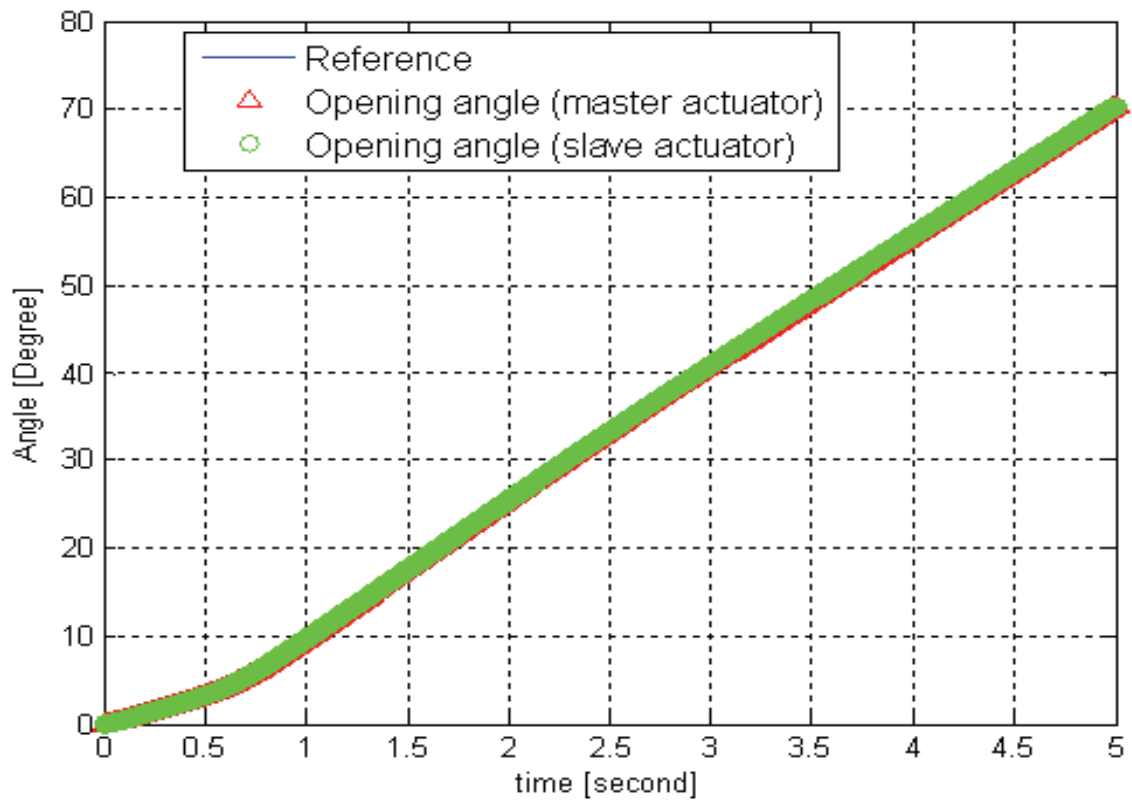

Fig. 13. Opening angles of the tailgate

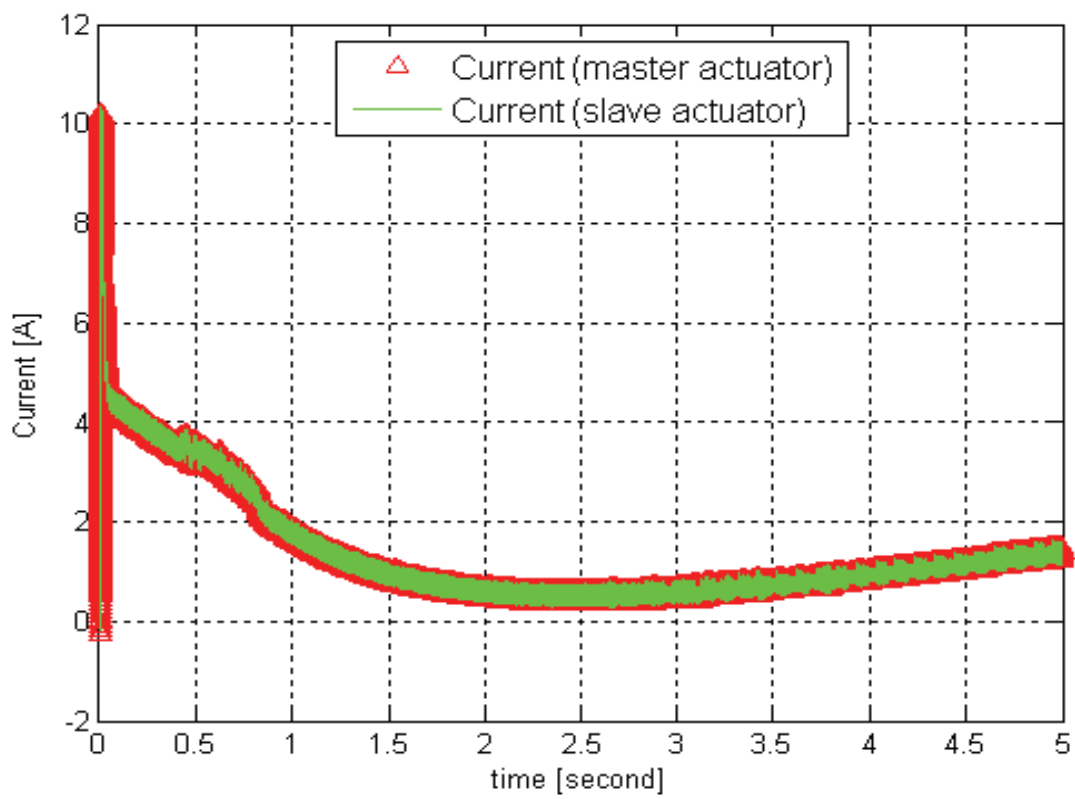

Fig. 14. Currents of the electric machines

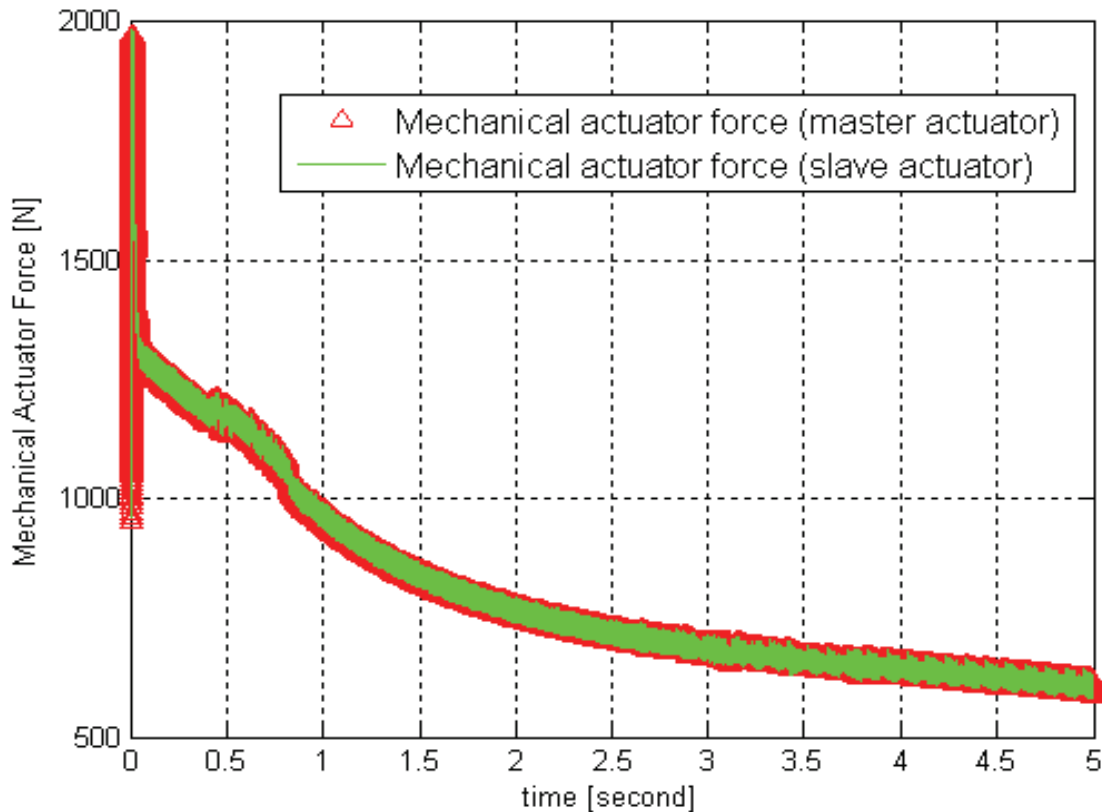

Fig. 15. Mechanic actuator forces

The results presented in figures 13, 14 and 15 are obtained by using the third level modeling for the dc-dc converters. Concerning the first and de the second levels modeling we have the same behavior but without oscillations. In addition, the imposed angular position in these levels is respected. The difference points between these three levels are concentrated on the simulation time which is increasing from first to third level and precision obtained on the outputs of system in order to reach its real behavior.

All simulations are performed using the same settings for different blocks of the system. The objective of these simulations is to test MATLAB/SIMULINK/SimPowerSys to model a mechatronic system type (motorized tailgate) and extract these different performances.

6. Performances analysis

The motorized tailgate is chosen to evaluate the performances of MALAB/SIMULINK/SimPowerSys and to test this tool to simulate a mechatronic system. To perform this analysis, some criteria's are considered (management of the multi-time scale, friction modelling and mechanical modelling in SIMULINK, electrical modelling using SimPowerSys, models implementation difficulties and time simulation of the opening phase...).

According to the implementation of the different part of the system and the all simulations carried out during this work, the table 1 summarizes the analysis of the criteria's defined previously.

The table 2 gives main advantages and disadvantages resulting from the modelling and simulation of the motorized tailgate in MALAB / SIMULINK / SimPowerSys.

Criteria's	Analysis
Management of the multi-time scale	This aspect is well treated in MALAB/SIMULINK, we can easily separate the different time constant of all the system to make the simulation faster
Frictions and mechanical modeling in SIMULINK	<p>These frictions are well modeled using block diagram with a condition to have all the physical equations.</p> <p>The disadvantage is that the mechanical model produces undesirable algebraic loop which increase considerably the simulation time.</p>
Electrical modelling using SimPowerSys	<p>This part of the system is well implemented by using the different components available in SimPowerSys library.</p> <p>Some model parameters are not explicit.</p> <p>Some models require information of many parameters which makes them unusable</p>
Models implementation difficulties	<p>Easy implementation of the different models using the block diagram of simulink with a condition to eliminate any algebraic loops.</p> <p>To model the electrical system with organ available in the library, we must have knowledge of the different parameters to inform, we must have an explicit instructions on the use of each organ and also their domain of validity.</p> <p>Knowledge related to the choice of the solver and its settings are needed to properly simulate the system in good conditions.</p>
Time simulation of opening phase	<p>The simulation is very faster when using the first and the second level of modelling for dc-dc converter. In the third level, the simulation is slower (existence of different time constants in the system) but it is improved by using multi-time scale and an accelerator mode of the used solver.</p> <p><i>For indication</i></p> <p>First level : 47.83 s (without accelerator) and 17.33 s (with accelerator)</p> <p>Second level : 49.84 s (without accelerator) and 17.21 s (with accelerator)</p> <p>Third level : 273.2 s (without accelerator) and 159.9 s (with accelerator)</p> <p><i>Characteristics of the used PC</i></p> <p>Dell Precision 390, Core 2 CPU 6400, 2.13 GHz, 2 Go RAM</p>

Table 1. Analysis of the criteria's

Advantages	Disadvantages
<ul style="list-style-type: none"> - Management of multi-time scale - Using models of electrical components (semiconductors, passive components, electrical machine) available in the SimPowerSystem library - Locating errors - We can inform about the component settings using script (. m) 	<ul style="list-style-type: none"> - Requires some decline on the implementation in block diagram in order to avoid algebraic loops - Not management of causality - Require the implementation of the mechanical part (components not available) - Setting difficult to some electrical components

Table 2. Main advantages and disadvantages of MALAB / SIMULINK / SimPowerSys

7. Conclusion

In this work, a mechatronic application (motorized tailgate) is studied to evaluate the simulation performances of MATLAB/SIMULINK/SimPowerSys. Firstly, the principle of this application is given and explained. Secondly, each part (electrical, mechanical and control) of this application are detailed. Then, the models representing the operation of each part are developed. A modeling in three levels of a dc-dc converter is proposed which allowed compromise between the simulation time and the simulation results accuracy. An implementation of the different parts by using block diagram in simulink and by using the available components in SimPowerSys library is carried out. The simulation results show that the imposed angular position of the tailgate is respected which validate the proposed cascade correction. Analyses of some performances of MATLAB / SIMULINK / SimPowerSys are given and the main advantages and disadvantage resulting from the implementation and simulation of the motorized tailgate are listed. It has been shown that the SimPowerSys suits well to simulate the electrical part of the tailgate. However, the modeling of the mechanical part by block diagram is not the best approach because it generates algebraic loops and the friction modeling is very hard. To overcome these difficulties, specific toolboxes of MATLAB/SIMULINK can be used (SimScape, SimMechanics).

8. References

- R. Juchem, B.Knorr, (2003) "Complete automotive electrical system design", Vehicular Technology Conference. VTC 2003-fall. 2003 IEEE 58th, 6-9 Oct, Volume 5, pp 3262 - 3266.
- Su, G.-J. Peng, F.Z. (2005) "A low cost, triple-voltage bus DC-DC converter for automotive applications", twentieth Annual IEEE, APEC. 6-10 March 2005, on page(s): 1015-1021, Vol. 2.
- Mutoh, N. Nakanishi, M. Kanasaki, M. Nakashima, (2005) "Control methods for EMI noises appearing in electric vehicle drive systems", twentieth Annual IEEE, APEC. 6-10 March 2005, on page(s): 1022-1028 Vol. 2.
- Joshi, R.P. Deshmukh, A.P. (2008) "Vector Control: A New Control Technique for Latest Automotive Applications (EV)", ICETET '08, 16-18 July, on page(s): 911-916.
- G. Remy, K. Ejjabraoui, C. Larouci, F. Mhenni, R. Sehab, P. Lefranc, B. Barbedette, S.A. Raka, C. Combastel, S. Cannou, F. Cardon, P. Cuvelier, C. Marchand, D. Barbier (2009) "Modeling guidelines and tools comparison for electromechanical system design in automotive applications", EMM 2009, 7th European Mechatronics Meeting. CIUP, Paris, France, June 24 & 25



Dynamic Modelling

Edited by Alisson V. Brito

ISBN 978-953-7619-68-8

Hard cover, 290 pages

Publisher InTech

Published online 01, January, 2010

Published in print edition January, 2010

When talking about modelling it is natural to talk about simulation. Simulation is the imitation of the operation of a real-world process or systems over time. The objective is to generate a history of the model and the observation of that history helps us understand how the real-world system works, not necessarily involving the real-world into this process. A system (or process) model takes the form of a set of assumptions concerning its operation. In a model mathematical and logical assumptions are considered, and entities and their relationship are delimited. The objective of a model – and its respective simulation – is to answer a vast number of “what-if” questions. Some questions answered in this book are: What if the power distribution system does not work as expected? What if the produced ships were not able to transport all the demanded containers through the Yangtze River in China? And, what if an installed wind farm does not produce the expected amount of energy? Answering these questions without a dynamic simulation model could be extremely expensive or even impossible in some cases and this book aims to present possible solutions to these problems.

How to reference

In order to correctly reference this scholarly work, feel free to copy and paste the following:

K. Ejjabraoui, C. Larouci, P. Lefranc, C. Marchand, B. Barbedette and P. Cuvelier (2010). Modelling and Design of a Mechatronic Actuator Chain Application to a Motorized Tailgate, Dynamic Modelling, Alisson V. Brito (Ed.), ISBN: 978-953-7619-68-8, InTech, Available from: <http://www.intechopen.com/books/dynamic-modelling/modelling-and-design-of-a-mechatronic-actuator-chain-application-to-a-motorized-tailgate>

INTECH
open science | open minds

InTech Europe

University Campus STeP Ri
Slavka Krautzeka 83/A
51000 Rijeka, Croatia
Phone: +385 (51) 770 447
Fax: +385 (51) 686 166
www.intechopen.com

InTech China

Unit 405, Office Block, Hotel Equatorial Shanghai
No.65, Yan An Road (West), Shanghai, 200040, China
中国上海市延安西路65号上海国际贵都大饭店办公楼405单元
Phone: +86-21-62489820
Fax: +86-21-62489821

© 2010 The Author(s). Licensee IntechOpen. This chapter is distributed under the terms of the [Creative Commons Attribution-NonCommercial-ShareAlike-3.0 License](#), which permits use, distribution and reproduction for non-commercial purposes, provided the original is properly cited and derivative works building on this content are distributed under the same license.

IntechOpen

IntechOpen