

# We are IntechOpen, the world's leading publisher of Open Access books Built by scientists, for scientists

4,800

Open access books available

122,000

International authors and editors

135M

Downloads

Our authors are among the

154

Countries delivered to

TOP 1%

most cited scientists

12.2%

Contributors from top 500 universities



WEB OF SCIENCE™

Selection of our books indexed in the Book Citation Index  
in Web of Science™ Core Collection (BKCI)

Interested in publishing with us?  
Contact [book.department@intechopen.com](mailto:book.department@intechopen.com)

Numbers displayed above are based on latest data collected.  
For more information visit [www.intechopen.com](http://www.intechopen.com)



## Expert System used on Heating Processes

Vizureanu Petrică

The "Gheorghe Asachi" Technical University from Iasi  
Romania

### 1. Introduction

The expert systems are numerical structures of regulating and automat control using an operation system, a programming environment and a series of execution organs that fulfill promptly the commands of the expert systems.

The thermal system represents the totality of the equipment and parameters of the thermal process concerning at the achieving of a heating region according to the technological conditions and these of the material to be processed.

The link between the expert system and the thermal system can be done through a logic and physic interface materialised in an alorythm and a hardware component. The relation between the two systems is that the expert system *determines* the thermal system, because the first is based on knowledge, professional experience (of human factor who build it!), as well as a logic reasoning, while the second is the necessary and sufficient infrastructure enabling the relation between the two systems (equipment, command elements, measurement apparatus etc.).

### 2. Industrial systems assisted by expert systems

An expert system undertakes a human problem of which solutions can be logically determined by a natural deductive system (natural system based on a series of solid knowledge) and codes it with the help of a computer. It results in this manner a software component that interprets the logical solution and transforms it into a codes solution. If all this process takes place in its expected order, then one can foresee the expected results.

The relevance of these systems results from the fact that the economy of energy is a priority for the human society, especially form Romania. The proposal estimates economies of resources up to 25 % on the assembly of the processing industry of metallic and non-metallic materials.

There is a *present tendency* in the development of industrial processes of thermal processing of materials, consisting in the computer assisting of processes and heating equipment, expressed here by the shape of thermal systems.

An another *national preoccupation* refers to the integration of the thermal processes among other fabrication processes by computer assisting.

The proposed expert system is a software instrument for the automate command of a heating system, with modern means, by processing the specific knowledge and expertise in the field. The automate planning of the technological process supposes the integration of the

Source: Expert Systems, Book edited by: Petrică Vizureanu,  
ISBN 978-953-307-032-2, pp. 238, January 2010, INTECH, Croatia, downloaded from SCIYO.COM

entire production process, integration between the constructive designing, computer aided-CAD, and the computer aided fabrication designing CAM, through a designing system of the technological process - CAPP. The system is an interactive medium, modern and efficient in view of technologies designing.

The system of planning of the technological process enable the rapid processing of knowledge, achieving a simple and efficient dialog with the user, the control and management of a great quantity of dots and necessary knowledge, the adequate representation of information of geometric and technical type.

The main goal is the implementation, in Romania, of this modern solution on international level for command, control and programming of the thermal equipment used in materials processing, in view to enabling economical revamping of the Romanian economic agents, by increasing the products quality and enabling a true competitiveness during UE integration, to ensure the stability on internal market and real succes in European competition.

The *expert systems* (figure 1) are numerical structures of regulating and automat control using an operation system, a programming environment and a series of execution organs that fulfill promptly the commands of the expert systems.

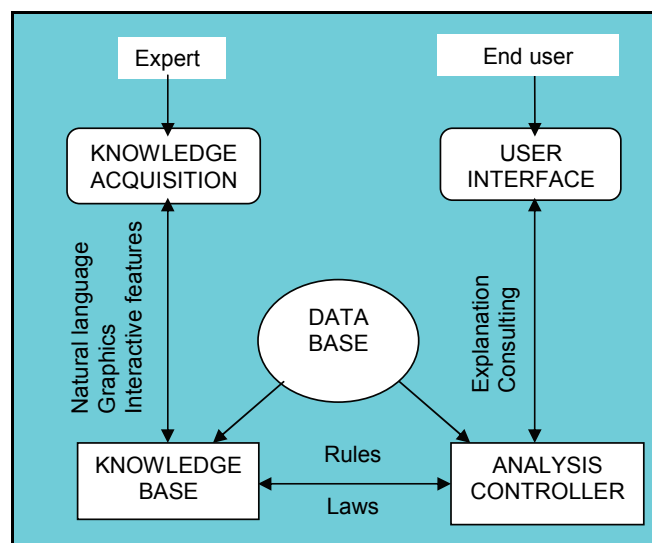

Fig. 1. The expert system.

**Knowledge accumulation** - specific for the field (in the shape of rules and laws), gathered by an expert and associated with the problem.

**Database** - relevant information, hystory, statistics, components, coefficients etc.

**Analysis, command** - analysis the rules, laws together with the actions of the user for the determination of the new conditions of identification of the possible solutions. The system will react in the field of the problem being based on the data base and using the input data from the **final user**.

**The user interface** - ensures the link between the expert system and user and designed in such a manner than to offer explanations of the system actions.

The *heating system* (figure 2) represents the totality of the equipment and parameters of the thermal process concerning at the achieving of a heating region according to the technological conditions and these of the material to be processed.

The **power source SP** can be constituted in a steady state convertor type M3, ensuring a three phase supplying of the thermal system with a continuum voltage.

**Heating elements R** ensures the temperature of the thermal process according to the technological needs.

**Measurement amplifiers A1, A2** used to increase the signals power from the temperature transducers.

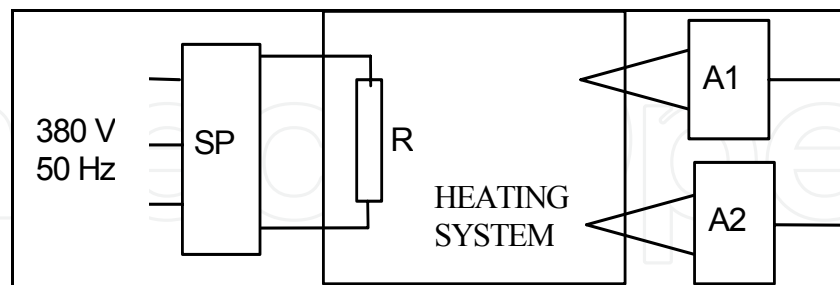

Fig. 2. The heating system.

The link between the expert system and the thermal system can be done through a logic and physic interface materialised in an algorithm and a hardware component. The relation between the two systems is that the **expert system** *determines* the **thermal system**, because the first is based on knowledge, professional experience (of human factor who build it!), as well as a logic reasoning, while the second is the necessary and sufficient infrastructure enabling the relation between the two systems (equipment, command elements, measurement apparatus etc.).

The variant A (figure 3) represents an expert system OFF-LINE type, the computer is not connected directly to the process and the exchange of data between the computer and the process is established by means of an operator. The computer receives information about the process by means of the operator that introduces the dates and following the processing the operator gets the results of the calculus and applies them in a manual manner in the process. In this case the computer is "off-line" (outside the line). The input dates referring to the process can be taken completely manual or in an automatic way. Such an expert system can be used in places when the delays do not matter and where the dates handling is not expressive.

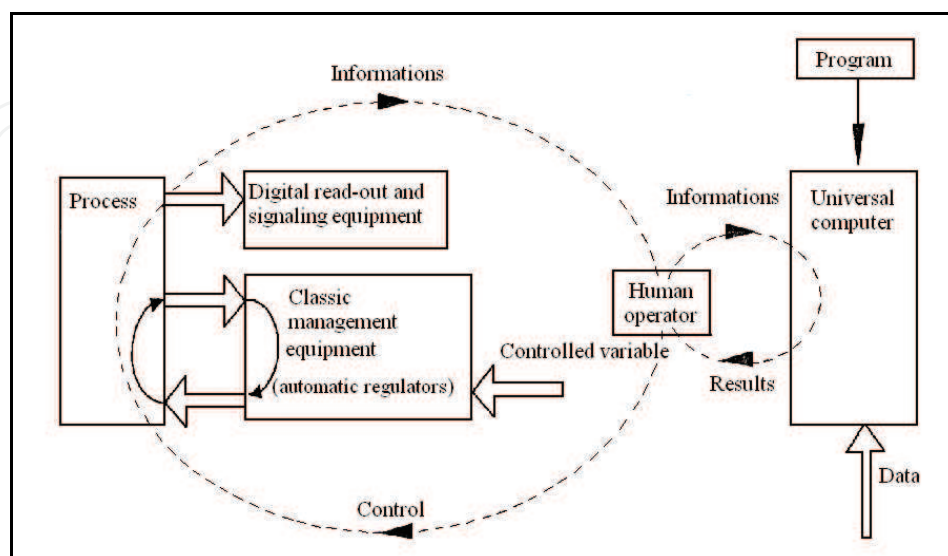

Fig. 3. The expert system OFF-LINE type.

The variant B (figure 4) represents an expert system of IN-LINE type: in the case of this kind of connecting the operator introduces dates concerning the process, directly in the computer, rapidly with the process, introduces in the computer can be processed immediately and the results are manually applied by the operator. In this type of expert system, as in the "off-line" one the information from the computer exists as shown as a typed message or on a display.

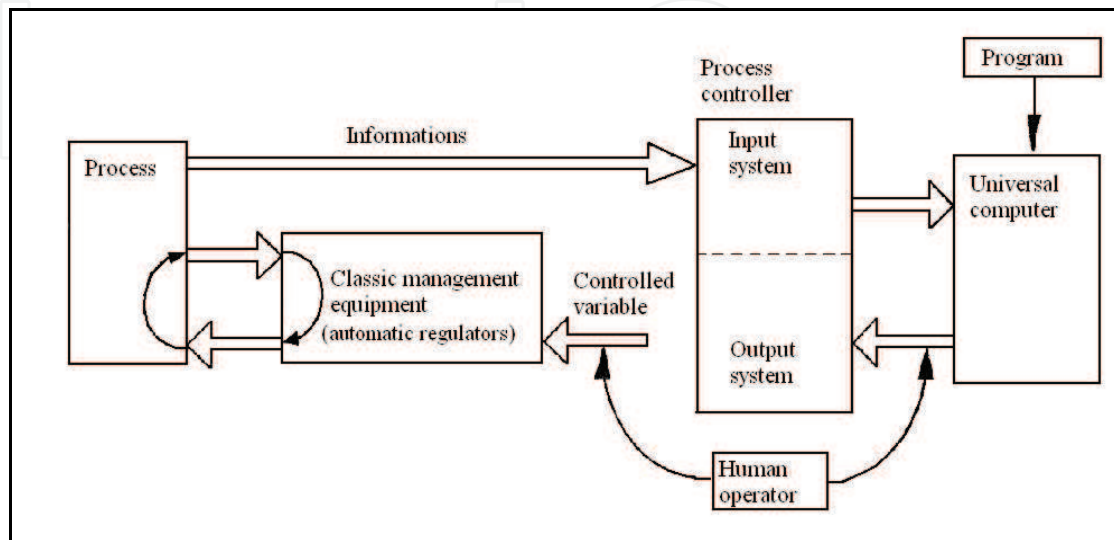

Fig. 4. The expert system IN-LINE type.

The variant C (figure 5) is an expert system of "ON-LINE" type: an expert system connected physically with the process so it gets information physically with the process so it gets information without human intervention and without delay.

The computer can get information directly from the process through its peripheries. In this case the computer works "on-line". The "on-line" system sends information from the process to the computer memory without immediately processing information, in a compulsory manner. When the processing of "on-line" sent information takes place immediately, during the process, the system is named "on line" in real time.

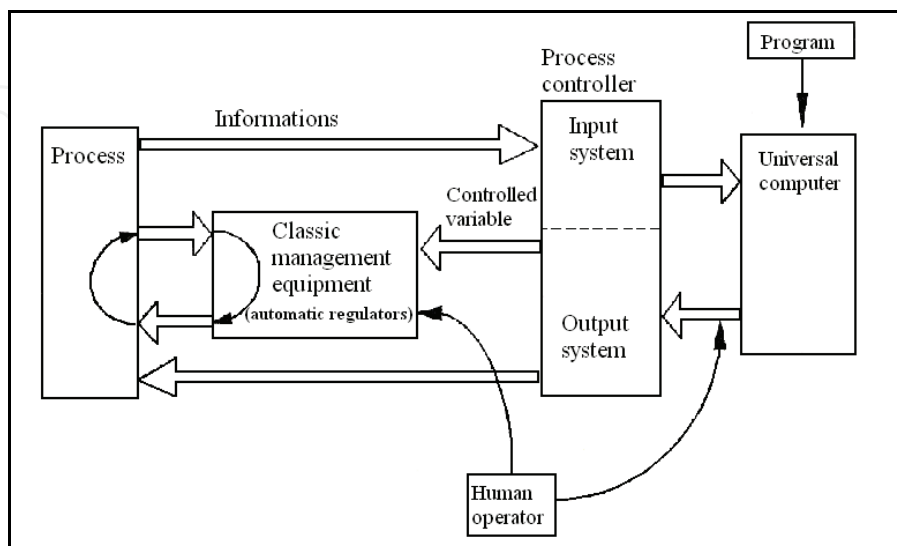

Fig. 5. The expert system ON-LINE type.

The output dates given by the computer after processing the inputs can be applied manually or directly to the process regulating devices. In the case of output dates transmission as messages and the decisions of commanding the regulation devices of the process, the system is named "on line" in open circuit, the computer operates in a regime "guide-operator", in the quality of process conduction consultant.

The variant taken into consideration is D (figure 6) because it shows the most advantages way of conducting because it can be implements on an existing conventional automation structure and in the case at failure of the computer the conduction of the process can be done with conventional equipments.

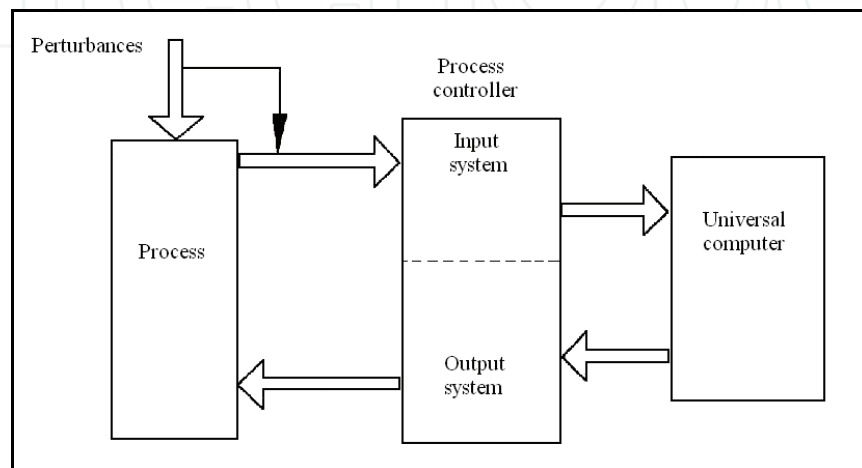

Fig. 6. The expert system ON-LINE type in closed circuit.

In the case there is no need of human intervention, the conduction actions are estimated by the computer and applied directly in the process, the system is called "ON LINE" in closed circuit.

### 3. Expert system designed for heating processes

The novel degree and the originality of such equipment consists in the regulation method that will be used as a combination between the variation of the quantity of energy in the heating elements and the variation of the connecting time of them as well as the replacing of the command of the thermal system, type "all or nothing" with a command with continuous regulation, ensuring in this way the growing of reliability and life duration of the thermal system.

In the figure 7 is shown the block scheme of on expert system of command of a thermal system is given; it is supplied at the industrial power network 380V, 50Hz and it has as a measurement parameter the temperature.

The power source SP can be constituted in a steady state convertor type M3, ensuring a three phase supplying of the thermal system with a continuum voltage.

**IBM - PC** represents a personal computer, compatible IBM, that has the role of numeric regulator and achieves it by the software component.

The **parallel programmable interface IPP** has as a purpose the expanding of the number of outputs available on the parallel standard interface LPT of a computer compatible IBM-PC. Given the necessity of existence of two parallel parts of 8 bytes, for data exchange with the block D/A and A/D, as well as a part for commands, for configuring the system, one can use a specialized circuit in the INTEL family.



The **block of digital-analogic conversion D/A** has as a purpose the supplied at its output of an electric signal (voltage or current), proportional with the numeric expression received at the output. In this case, through the foreseen channel in the block scheme, the block D/A receive from the IBM-PC system a numeric value and supplies at the output a continuum voltage ranging between 0-10V, necessary for the command of the power source SP.

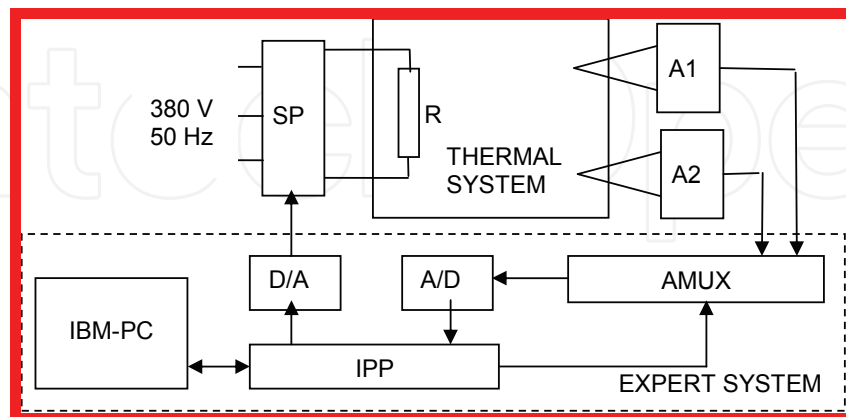

Fig. 7. The expert system for heating system programming.

The **block of analogic-digital conversion A/D** supplies at the output a number in binary representation, proportional with the analogical measure from the output. The convention A/D supposed the superposition of the input signal at two operations: sampling and quanting. The first operating defines the temporal aspect of the conversion and the way of taking the sample and the second defines even the way of obtaining of the numeric equivalent of the analogue measure.

The **block of analogic multiplexing AMUX** has the role to enable the reception of ware electric signals on a single channel, it actually achieves a time partitioning of the input channel of the block A/D. The analogic multiplying operating needs commutation devices to direct the useful signal on a desire channel. In a simple variant the analogic switch can be assimilating with a rotative switch with a position or with an ensemble of  $n$  swiches one being closed during the other stay opened.

**Measurement amplifiers A1, A2** - the majority of the expert system working with analogic dates work with high level tension signals (0.5V, 0..10V), but not always the transducers used (in the case of measuring some non-electrical measures) can supply such signals. It appears the necessity of amplifying the signals supplied towards the expert system up to values compatible to these it is able to read as input data. For solving this problem the measure amplifies are being used. The practical implementing of the measurement amplifies has at the basis the operational amplifiers that is capable to ensure a big gain in a wide range of frequencies and as characterized by symmetric output, amplification and input impedance very big.

Performance parameters of the system:

- Ensuring a precision of achievement of the heating diagram in the range 3 and 5 °C;
- Achieving of an energy recovery, comparing eith the classic varriant of the thermal system about 25 %, economic efficiency estimated as an average of the solutions that will be applied in industry;
- The expert system achieved will enable the obtaining of low heating speeds of 8 - 10 °C/h.

Quality parameters of the system:

- The functioning of the proposed solution at the series production level;
- The industrial implementation with minimum costs of the new proposed technology;
- The success rate of the application (degree of repetability of the results);
- The clarity of definition and framing of the technologic parameters according to the estimated success rate in industrial conditions.

Estimated technical performance:

- The thermal system functional revamping;
- Simplifying the thermal system elements;
- The significant growing of thermal systems durability;
- The enhance of the fiability in exploitation of the industrial thermal systems with 8 - 10 %;
- The productivity growing by reduction of technological operation and a fabrication cycle with 10 %.

Prognosed economic efficiency:

- The development of the production capacity by upgrading the fabrication technology;
- The productivity growing goes to the significant growing of profitability for potential economical partners, when they will produce such expert systems;
- The oportunity of valorization of product, inside and outside market, because of big demanding that exists and because the advantages that the system have;
- Growing of skill level of people by expert systems implementation.

Impact on technological development at regional level:

- Promotion at the regional level of a higher performance and quality level of the technologies/products through the collaboration among partners of the same unfavorable region;
- The increase of the competence level through re-technology based on the modernizing and research, through the initiation of the partner among the economic agents and the research-development units.

The impact on the scientific and technical medium:

- The increase of the agents' economic capacity to assimilate in an efficient way the latest technologies and the results of the research activity;
- The development within the D-R units of the activity of promoting new materials and technologies, as well as of the advanced analysis and control techniques.

Social and medium impact:

- Social stability through the improvement of the economic medium;
- Creation of new working places and the perfecting of the working force which will assure the success of the technological transfer and the efficient implementation of the proposed solution;
- The increase of the biosecurity and bioethical levels through stimulation within the project of the responsible factors of ec. agents to enforce working discipline and the environment protection through the personnel conscience in the perspective of Romania's adherence in the EU.

Economical impact:

- The increase of economic efficiency at the level of the beneficiary through the reducing of the manufacturing expenses and maintenance of the heating systems;
- The possibility to obtain new contracts in order to assure financial stability and investments;



- The extension of the application field through the diversity of the heating systems, obtained through the technical solution;
- The increase of the affair figure through the promotion of quality and new products.

#### 4. Expert system designed for heat treatment furnaces

Measurement and control digital systems had mainly enforced in the last decades cause to the technological revolution within electronic components domain. It is hereby obtained a bigger accuracy in digital information processing by facilitating the direct connecting with computer, a bigger speed work and an increased automation degree of the process.

The expert system is made on the basis of an original mathematical model theoretically and experimentally obtained. The mathematical model respects and combines static and dynamic behavior of an industrial furnace and the model of a temperature regulator with PID behavior.

Measurement and numeric control (digital) systems have mainly imposed in the last decades because the technological revolution within electronic components domain. It is thus obtained a bigger accuracy in numeric information processing by facilitating the direct connection with computer, a higher work speed and an increased automation degree of the process.

It was accomplished an original "on-line" management system in closed circuit with gradual command of heating electric power and self-adaptive control with PID behavior of temperature. The hard structure is made of a command unit with thyristor connected to an electronic device specialized on its interface with an electronic computer.

The calculus program is based on an original mathematical model theoretically and experimentally obtained. The mathematical model respects and combines static and dynamic behavior of an electric furnace and the model of a temperature regulator with PID behavior. That is why the model can be used for any other furnace than the one used during experiments. As any theoretical model, it has a lot of coefficients whose identification can be made only experimentally in order to respect the constructive functional particularities of the installation.

The expert system assures the self-adjusting parameters of the temperature regulator with PID through the indicial response method of the furnace. Taking into consideration the experimental knowledge necessity of the furnace constructive functional characteristics it was made the first experiment to determine its indicial response. The gradual command of heating power was realized by using thyristor commanded in phase angle. In this case the relation between power and command angle  $\Psi$  is (Ciochina & Negrescu., 1999):

$$P = \frac{U_s^2}{R} \left( 1 - \frac{\psi}{\pi} + \frac{\sin 2\psi}{2\pi} \right) \quad (1)$$

The variation of command angle of  $\pi$  radians corresponds to a variation of  $U_{com}$  command tension from the exit of digital-analogical converter of 10 V thus,  $U_{com} = 0$  V corresponds to the angle  $\psi = \pi$  (rad), and  $U_{com} = 10$  V corresponds to the angle  $\psi = 0$  (rad). Hence there is a relation:

$$\psi = \pi - \frac{U_{com}}{10} \pi \quad (2)$$

or

$$\frac{\psi}{\pi} = 1 - \frac{U_{com}}{10} \quad (3)$$

$$2\psi = 2\pi - U_{com} \frac{\pi}{5} \quad (4)$$

It results the relation:

$$P = \frac{U_s^2}{R} \left( \frac{U_{com}}{10} + \frac{\sin\left(\frac{\pi U_{com}}{5}\right)}{2\pi} \right) \quad (5)$$

The relation between variator theme  $U_{com}$  and the number of bits applied to digital - analogical converter on eight bits is:

$U_{com} = 10$  V - corresponds to a number of 256 bits

$U_{com} = 0$  V - corresponds to a number of zero bits

It results that at an  $U_{com}$  tension  $N$  bits will correspond after the formula:

$$N = \frac{U_{com} \cdot 256}{10} \text{ (biti) } \text{ sau } U_{com} = \frac{10N}{256} \quad (6)$$

To angle  $\psi=0$  will correspond the power  $P = \frac{U_s^2}{R} = P_{maximă}$ , and to angle  $\psi = \pi$  will correspond power  $P=0$ . Hence we can write that:

$$P = P_{MAX} \left( 1 - \frac{\psi}{\pi} + \frac{\sin 2\psi}{2\pi} \right) \quad (7)$$

Replacing  $\psi$  we can write:

$$P = P_{MAX} \left( \frac{U_{com}}{10} + \frac{\sin\left(\frac{\pi U_{com}}{5}\right)}{2\pi} \right) \quad (8)$$

Expressed with the help of a bits number:

$$P = P_{MAX} \left( \frac{N}{256} + \frac{\sin\left(\frac{2\pi N}{256}\right)}{2\pi} \right) \quad (9)$$

The program is based on a logical scheme forwards presented in figure 8.

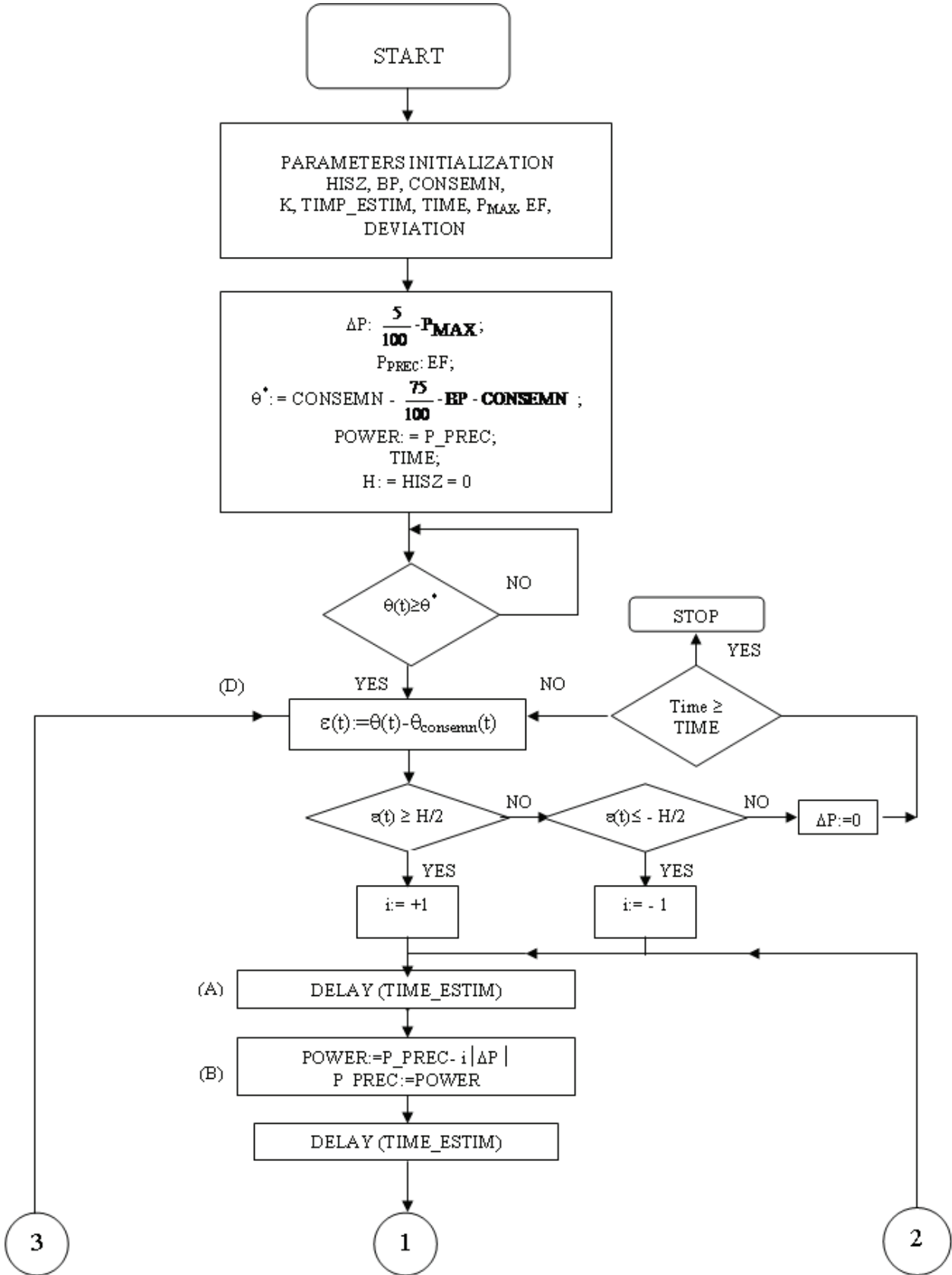

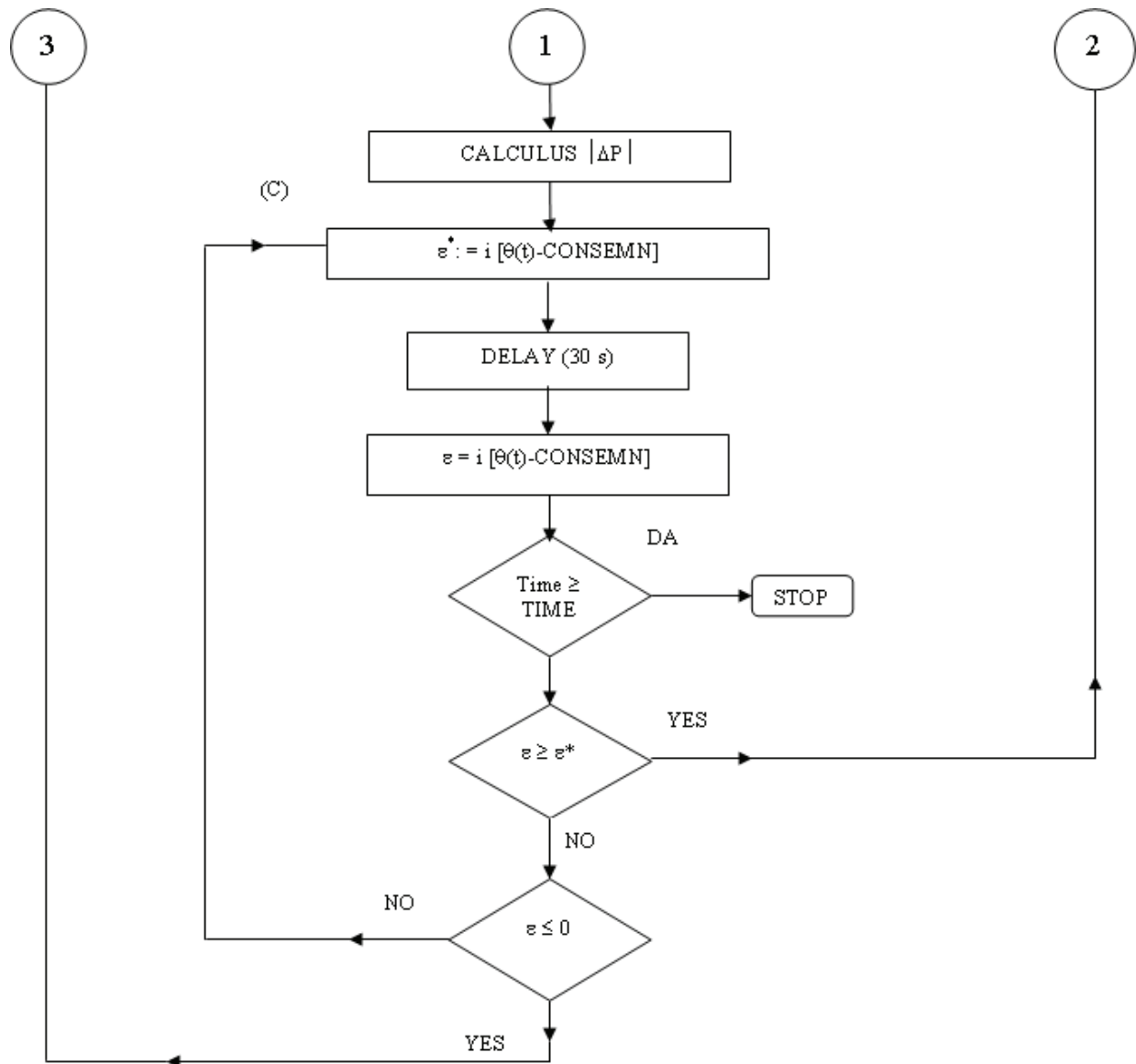

Fig. 8. Logical scheme of the expert system programming.

Mathematical model correspond to following steps:

I. Parameters initialization:

1°. Consign temperature (CONSEMN) (°C)

2°. Proportionality band (BP) (%): 5% ... 40%

3°. Hysteresis (HISZ) meaning  $\max |\theta_{\text{measured}}(t) - \theta_{\text{programmed}}(t)|$ : 2°C ... 5°C

4°. Initial power applied to furnace (EF) (%):  $(60 \dots 80) \times P_{\text{MAX}}/100$

5°. Time (TIME), (min)

6°. Sampling quantum (K): 10 ... 15 seconds

7°. Estimate time (TIME\_ESTIM) of  $T_u$  and  $V_{\text{MAX}}$  parameters: 3 ... 4 min

8°. Admitted maximum deviation (ABATERE) meaning:

$$\max |\theta_{\text{mäsarat}}(t) - \theta_{\text{estimat}}(t)| : 1 \dots 3^\circ\text{C}$$

II. The furnace is at ambient temperature thus we apply an initial power equal to that which was adjusted at aforementioned point 4° (EF).

III. When the furnace temperature  $\theta(t)$  has the value:

$$\theta(t) \geq \text{CONSEMN} - \frac{75}{100} \times BP \times \text{CONSEMN} \quad (10)$$

We will verify the Hysteresis condition:

$$|\text{CONSEMN} - \theta(t)| \leq \frac{\text{HISZ}}{2} \quad (11)$$

If temperature respects this condition the power must not be modified ( $\Delta P=0$ ).

If the measured temperature does not respect this condition it should be applied a supplementary power step after the following algorithm:

1°. Sampling quantum (expressed in seconds) is  $K$  and sampling time ( $\text{TIMP\_ESTIM}$ ) (expressed in minutes) it will result a quanta number:

$$\text{number} = \frac{\text{TIMP\_ESTIM} \times 60}{K} \quad (12)$$

In time range  $\text{TIMP\_ESTIM}$  we will memorize the temperatures values measured at equal time intervals ( $K$ ) in the rank:

$$\text{TEMP\_TC}_2[j]$$

where  $j$  index is varying from a maximum value of quanta number, aforementioned number (in logical scheme - see A block).

2°. It applies a supplementary power step to the furnace:  $5/100 P_{\text{MAX}}$ .

Taking into consideration the approximate linear variations on small time intervals of 3-4 minutes order ( $\text{TIMP\_ESTIM}$ ) we could estimate the evolution of temperature in the furnace if it was not applied the above power step.

We note with (1) the variation of temperature in furnace measured in 0-T interval ( $T = \text{TIMP\_ESTIM}$ ) in figure 9. Without supplementary power step the temperature evolved in (T-2T) interval after curve (1), which we could approximate as AB line noted with (2) on a smaller time interval ( $T-3T/2$ ). The line gradient (2) is calculated like this:

We trace a line 0A and measure it in moment  $T/2$  as a difference:

$$\theta\left(\frac{T}{2}\right) - \frac{\text{TEMP\_TC}_2[0] + \text{TEMP\_TC}_2[T]}{2} = \text{ECART} \quad (13)$$

We prolong the line 0A until it meets C point where the ordinate value will be:

$$\text{DREAPTA}[2T] = 2 \times \text{TEMP\_TC}_2[2T] - \text{TEMP\_TC}_2[0] \quad (14)$$

We find B point by decreasing for five times the value of temperature range, value which is experimentally determined for temperature tangent variations not bigger than  $1^\circ\text{C}/\text{min}$ .

In order to estimate temperature I made the row:

$$\text{BETA}[q] = \text{DREAPTA}[\text{numar}] + q \times \left( (\text{DREAPTA}[2 \times \text{numar}] - 5 \times \text{ECART}) - \text{DREAPTA}[\text{numar}] \right) / \text{numar} \quad (15)$$

where  $q$  index is varying from 0 to a maximum value= number (in logical scheme see the B block).

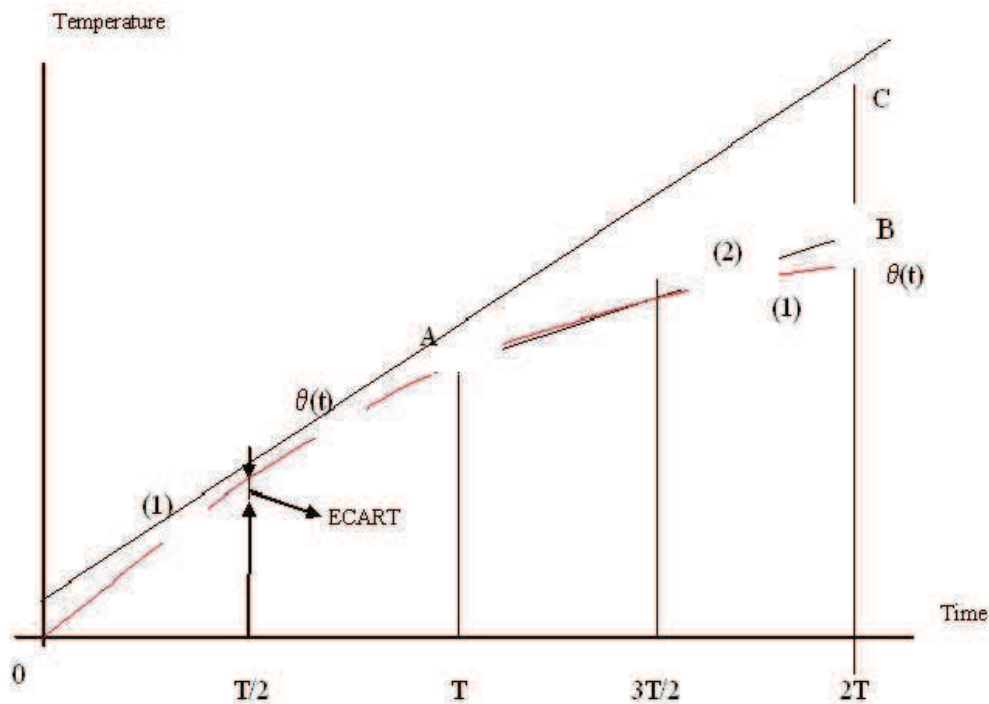

Fig. 9. Graphical representation of the estimation model of temperature evolution.

3°. In  $(T-2T)$  time interval we verify the condition:

$$TEMP\_TC_2[q] - BETA[q] \leq ABATERE \quad (16)$$

For  $q=1 \dots$  number, meaning the maximum deviation between the measured value and the estimate one which should not excel the adjusted value.

The last index  $q$  that satisfies the above condition will give us  $T_u$  into a first estimation:

$$T_u = q \times K$$

4°. At the end of  $T$  period we can calculate  $tg\alpha_{max} = V_{max}$ , according to figure 10, which graphically represent the determination method of calculus parameters implied in the calculus of PID continuous regulator.

$$V_{max} = \frac{\theta(T) - \theta(i \cdot K)}{T - i \cdot K}, \quad (17)$$

where  $i \cdot K = T_u$ , the one from the first estimation (point 3°).

But  $V_{max}$  can be also expressed as:

$$V_{max} = \frac{\theta(i \cdot K)}{i \cdot K - t_m} \quad (18)$$

This will let us recalculate the time  $T_u$ :

$$T_u = t_m = i \cdot K - \frac{\theta(i \cdot K)}{V_{max}} \quad (19)$$



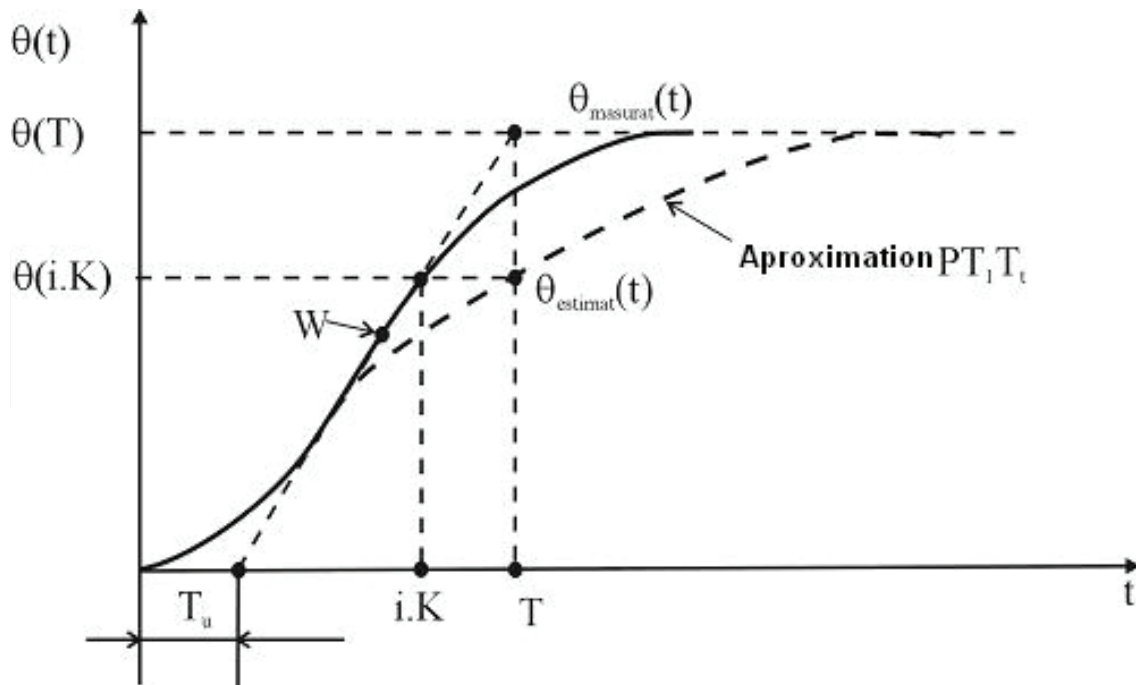

Fig. 10. Graphical calculus model used in determining the parameters of continuous PID regulator

IV. At the end of T period we could calculate:

$$\int_0^T \theta_{masurat}(t)dt \quad \text{și} \quad \int_0^T \theta_{estimat}(t)dt. \quad (20)$$

$$\Delta W = K_R \left( \int_0^T \theta_{masurat}(t)dt - \int_0^T \theta_{estimat}(t)dt \right) \quad (20)$$

$$\frac{\Delta W}{T} = P(T) - P(0) \quad (21)$$

In relation (21) P (0) represents the old power step and P (T) the new power applied to the furnace. It results:

$$K_R = \frac{T[P(T) - P(0)]}{\int_0^T \theta_{masurat}(t)dt - \int_0^T \theta_{estimat}(t)dt} \quad (22)$$

Now we know the nest parameters at the end of T period:  $T_w$ ,  $V_{max}$  and  $K_R$ , which are essential to recalculate the parameters  $K_P$ ,  $T_I$  and  $T_D$  in the case of a continuous PID regulator.

V. In order to reach the desired temperature  $\theta_{consemn}$  it will be necessary to apply a power step:

$$\Delta P = K_R \cdot \left[ K_P (\theta_{consemn} - \theta(T)) + \frac{1}{T_i} \cdot \int_0^T (\theta_{consemn} - \theta(t))dt + T_d \cdot \frac{d(\theta_{consemn} - \theta(t))}{dt} \right] \quad (23)$$

where  $K_P$ ,  $T_I$  and  $T_D$  will be calculated accordingly to the next empirical rules deduced by applying Ziegler-Nichols method (the method of indicial response):

$$K_P = \frac{\theta_{consemn}}{1,7 \cdot V_{\max} \cdot T_u \cdot 100}, \quad T_I = 2T_u, \quad T_D = 2T_u$$

It results:

$$\Delta P = K_R \cdot \left[ \frac{\theta_{consemn}}{1,7 \cdot V_{\max} \cdot T_u \cdot 100} (\theta_{consemn} - \theta(T)) + \frac{1}{2T_u} \cdot \frac{\theta(0) - \theta(T)}{2} T + 2T_u \frac{\theta(0) - \theta(T)}{T} \right] \quad (24)$$

VI. After calculating the power step  $\Delta P$  necessary for reaching the prescribed consign temperature (CONSEMN) we will measure a difference  $\varepsilon^* = \theta(t) - \text{CONSEMN}$  and after a period of 30 seconds we will measure again:

$$\varepsilon = \theta(t) - \text{CONSEMN} \quad (25)$$

If the time (time) overcomes the adjusted value TIME, the adjusting process ends (block STOP from logical scheme). If not, we will continue testing if it takes place a diminishing of the distance between measured and prescribed temperature in these 30 seconds (CONSEMN),  $\varepsilon \geq \varepsilon^*$ .

If the distance increases is obvious that we should recalculate the power step  $\Delta P$ .

If the distance decreases ( $\varepsilon < \varepsilon^*$ ), but  $\varepsilon > 0$ , we will recalculate  $\varepsilon^*$  and  $\varepsilon$  (back to block (C) from logical scheme).

If, this time,  $\varepsilon \leq 0$  it is moment to resume testing the Hysteresis interval (block (D) in logical scheme).

According to research methodology presented the constructive-functional improvement of heat treatments installations for copper alloys realized on determination base through experimental methods of theoretical mathematical models parameters. These demonstrate the complexity of the construction and functioning of these installations. This expert system assures the accuracy and uniformity of temperature within charge.

The experimental researches were made at Faculty of Materials Science and Engineering, The "Gh. Asachi" Technical University of Iasi, within the department of Plastic Processing and Heat Treatments, at S.C. "COMES" S.A. Savinesti, Neamt and at S.C. "PETROTUB" S.A Roman, Neamt, Romania.

The installation used for experiments was a CE 10-6.6.4 electric furnace made by „Independenta" Sibiu, Romania and having a command, adjust and control panel made once with the furnace by the same productive firm. This type of installation can be found in the use of many heat treatments departments of the firms from the entire country not only in machine constructions domain or metallurgical one.

## 5. Conclusion

In order to obtain the precision of temperature (imposed by the technological demands) it was replaced the panel within the furnace with an original leading system and the uniformity of temperature in charge was realized an auxiliary heating device closed muffle type where the pieces were placed. The necessity of using an auxiliary heating device came

from the conclusions of the experiments made with the initial heat treatment installation no-load and on load that showed the existence of some high temperature differences unallowable for copper alloys especially at the furnace arch and base of hearth.

Choice criteria for muffle form and material start from the phenomena of the complex heat transfer within the furnace, the furnace construction (useful space and heating elements disposal), the treated charge type (alloy, shape and dimensions for the pieces, pieces laying in the auxiliary heating device), the characteristics of used metallic materials (high alloyed refractory steels) such as mechanical strength at high temperatures, resistance to creep, refractoriness, thermal conductivity.

There of it was used the auxiliary heating device of T20CrNi370 austenitic alloy - SR-EN 6855-98.

From the dependency analysis between the view factors value between two parallel surfaces where there exist heat transfer through radiation and the distance size between that surfaces it results that the muffle walls must be as closer as possible to the heating elements (mounted in the walls).

From the conclusions of thermal fields in closed metallic muffle cubic and cuboids (presented in the fourth chapter of the paper) we chosen the cubic form with the dimensions 450x450x450 [mm] for the auxiliary heating device. The construction was welded in closed variant without cover sealing.

The expert system contains a hard structure and a specialized soft. Both were realized by taking into consideration the specific of the used installation (furnace power, thermocouples type, the indicial response of the furnace) and they form an „ON-LINE” self adaptive leading system in closed circuit with PID temperature adjusting.

## 6. References

- Bhadেশia, H.K.D.H., (1999) *Neural network in materials science*, ISIJ International, vol. 39.
- Ciochină, S., Negrescu, C., (1999) *Sisteme adaptive*, Colecția Comunicații, 352 p.
- Dima, A., Vizureanu, P., (1997) About Software and Hardware Control on the Heat Processing Furnaces, *IV<sup>th</sup> International Conference Measurement and Control in Complex Systems*, Vinnytsia, p. 222-225.
- Dumitrescu, D., (1999) *Principiile inteligenței artificiale*, Ed. Albastră, Cluj-Napoca.
- Edenhofer, B., (1990) La flexibilité en traitement thermique grâce aux méthodes modernes de contrôle, *Revue de Traitement Thermique*, Nr. 241, p.20-27.
- Garnearek, Z., (1992) Degree of heterogeneity of thermal: a method of evaluation, *Heat and Mass Transfer* Nr. 11, p. 30-36.
- Hallday, W., (1998) Model computerizat pentru controlul cuptoarelor de recoacere, *Steel Times International*, Anglia, vol. 12, nr. 6, decembrie 1998, p. 22-23.
- Hatasescu, O., (1998) *Indreptar de metalurgie*, Editura Tehnică, Bucuresti, Romania.
- He Jian-jun, Yu Shou-yi, (2005) Temperature Intelligent Control System of Large-Scale Standing Quench Furnace, *Journal of Electronic Science and Technology of China*, Vol.3 No.1, Mar. 2005.
- Henrik A., (2005) *Simulation of Welding and Heat Treatment Modelling and Validation*, Doctoral Thesis:33 ISSN: 1402-1544, ISRN: LTU-DT - -05/33 -SE.
- Higuchi, S., Allen, G., W. Bencze, R. Byer, A. Dang, D. B. DeBra, D. Lauben, S. Dorlybounxou, J., Hanson, L., Huffman, F., Sabur, K. Sun, R. Tavernetti, L. Rolih, R. VanPatten, Wallace, J. Williams, S. (2006) High-stability temperature control for ST-

- 7/LISA Pathfinder gravitational reference sensor ground verification testing, *Journal of Physics: Conference Series* 32 125-131.
- Kang, J., Rong, Y., Wang, W. (2004) Numerical simulation of heat transfer in loaded heat treatment furnaces, *Journal of Physics*, Vol. 4, France, No. 120, pp. 545-553.
- Lalam, Sree Harsha, (2000) *Modelling of Mechanical Properties of Ferritic Steel Weld Metals*, University of Cambridge, UK.
- Lilantha S. (2003) *Distributed Control of Electric Drives via Ethernet*, TRITA-ETS-2003-09, ISSN 1650{674xISRN KTH/EME/R 0305-SE}, Stockholm 2003.
- Lazăr, C., Păstrăvanu, O., Poli, E., Schonberger, F., (1996) *Conducerea asistată de calculator a proceselor tehnice*, Editura Matrix Rom, București.
- Mackay, David J.C., (1995) Bayesian No-Linear Modelling with Neural Networks, *University of Cambridge, Programme for Industry*, March 6, UK.
- Malinov, S., Sha, W., (2003) Software products for modelling and simulation in materials science, *Computational Materials Science* 28, 179-198.
- Nicolae, A., Predescu, C., (2001) *Bazele teoretice ale agregatelor termotehnologice din industria materialelor metalice*, Editura Printech, București.
- Nilsson, N., (2001) *Introduction to Machine Learning*, <http://robotics.stanford.edu/people/nilsson/mlbook.html>.
- Partridge, D., Hussain, K.M., (1995) *Knowledge Based Information Systems*, Mc Graw-Hill Book Company Europe, London.
- Singh S.B. et al., (1999) Neural Network Analysis of Steel Plate Processing, *Iron making and Steel making*, vol. 25, no. 5, p. 355-365.
- Sourabh C., (2006) Transformation in TRIP-assisted Steels : Microstructure and Properties, *PhD Thesis, University of Cambridge*, UK.
- Ștefan, M., Bădărău, Gh., Ioniță, I., Vizureanu, P., Răileanu, T., Baciuc, C., Manole, V., Mihai, D., (2007) *Conducerea automată și informatizată în procesarea materialelor metalice*, Editura Tehnopress, Iași, 372 pg., ISBN 978-973-702-438-1
- Ștefan, M., Vizureanu, P., Bejinariu, C., Manole, V., (2008) *Baze de date și sisteme expert în selecția și proiectarea materialelor*, vol. I, Editura Tehnopress, Iași, 298 pg., ISBN 978-973-702-514-2
- Vermesan, G., (1987) *Tratamente termice*, Editura Dacia, Cluj, Romania.
- Veronesi M. (2003) Performance Improvement of Smith Predictor Through Automatic Computation of Dead Time, *Yokogawa Technical Report English Edition*, No. 35.
- Vizureanu, P., (1998) Modern System for Heat Treatment Assisted by Computer, *Modelling and Optimisation in the Machines Built Field*, Romanian Academy, p.137-141.
- Vizureanu, P., (2005) Process Control Strategy on Industrial Furnaces, *37th International Conference on Mining and Metallurgy, Proceedings*, Bor, 3-6.10.2005, Serbia, p. 376-379.
- Vizureanu, P., (2006) *Experimental Programming in Materials Science*, Mirea Publishing House, Moscow, 2006, 116 pg., ISBN 5-7339-0601-4
- Vizureanu, P., Andreescu, A., Iftimie, N., Savin, A., Steigmann, R., Leițoiu, S., Grimberg, R., (2007) Neuro-fuzzy expert systems for prediction of mechanical properties induced by thermal treatments, *Buletin I.P.Iași*, tom LIII (LVII), fasc. 2, secția Știința și Ingineria Materialelor, 2007, pg. 45-52.
- Vizureanu, P., Ștefan, M., Baciuc, C., Ioniță, I., (2008) *Baze de date și sisteme expert în selecția și proiectarea materialelor*, vol. II, Editura Tehnopress, Iași, 2008, 262 pg. (40 rânduri/pg.) ISBN 978-973-702-515-9

- Vizureanu, P., (2009) *Echipamente și instalații de încălzire*, Editura PIM, Iași, 2009, 316pg., ISBN 978-606-520-349-5.
- Wang, D. M., (1993) An approximate solution for the dynamic response of wall transfer probes, *Heat and Mass Transfer* nr. 18, p.12-17.
- Xu Xiaoli, Wu Guoxin and Shi Yongchao, (2005) Development of intelligent system of thermal analysis Instrument, *Journal of Physics: Conference Series* 13 59–62.
- Yescas, M.A., (2001) Modelling the Properties of Austempered Ductile Cast Iron, *PhD Thesis, University of Cambridge, UK*.
- Zang, X., (1993) *Les perturbations générées par les gradateurs alimentant des Charges resistives et inductives constants et solutions*, EDF.
- \*\*\*, *Heat Treating of Copper Alloys*, Heat Treatment, v.4, ASM International, (1994), p.821-889.
- \*\*\*, *Standards: EN 10028, EN 10137, EN 10113*.

IntechOpen



## **Expert Systems**

Edited by Petrica Vizureanu

ISBN 978-953-307-032-2

Hard cover, 238 pages

**Publisher** InTech

**Published online** 01, January, 2010

**Published in print edition** January, 2010

Expert systems represent a branch of artificial intelligence aiming to take the experience of human specialists and transfer it to a computer system. The knowledge is stored in the computer, which by an execution system (inference engine) is reasoning and derives specific conclusions for the problem. The purpose of expert systems is to help and support user's reasoning but not by replacing human judgement. In fact, expert systems offer to the inexperienced user a solution when human experts are not available. This book has 18 chapters and explains that the expert systems are products of artificial intelligence, branch of computer science that seeks to develop intelligent programs. What is remarkable for expert systems is the applicability area and solving of different issues in many fields of architecture, archeology, commerce, trade, education, medicine to engineering systems, production of goods and control/diagnosis problems in many industrial branches.

### **How to reference**

In order to correctly reference this scholarly work, feel free to copy and paste the following:

Vizureanu Petrică (2010). Expert System Used on Heating Processes, Expert Systems, Petrica Vizureanu (Ed.), ISBN: 978-953-307-032-2, InTech, Available from: <http://www.intechopen.com/books/expert-systems/expert-system-used-on-heating-processes>

**INTECH**  
open science | open minds

### **InTech Europe**

University Campus STeP Ri  
Slavka Krautzeka 83/A  
51000 Rijeka, Croatia  
Phone: +385 (51) 770 447  
Fax: +385 (51) 686 166  
[www.intechopen.com](http://www.intechopen.com)

### **InTech China**

Unit 405, Office Block, Hotel Equatorial Shanghai  
No.65, Yan An Road (West), Shanghai, 200040, China  
中国上海市延安西路65号上海国际贵都大饭店办公楼405单元  
Phone: +86-21-62489820  
Fax: +86-21-62489821



© 2010 The Author(s). Licensee IntechOpen. This chapter is distributed under the terms of the [Creative Commons Attribution-NonCommercial-ShareAlike-3.0 License](#), which permits use, distribution and reproduction for non-commercial purposes, provided the original is properly cited and derivative works building on this content are distributed under the same license.

IntechOpen

IntechOpen