

We are IntechOpen, the world's leading publisher of Open Access books Built by scientists, for scientists

4,800

Open access books available

122,000

International authors and editors

135M

Downloads

Our authors are among the

154

Countries delivered to

TOP 1%

most cited scientists

12.2%

Contributors from top 500 universities



WEB OF SCIENCE™

Selection of our books indexed in the Book Citation Index
in Web of Science™ Core Collection (BKCI)

Interested in publishing with us?
Contact book.department@intechopen.com

Numbers displayed above are based on latest data collected.

For more information visit www.intechopen.com



Humanoid Robot With Imitation Ability

WEN-JUNE WANG and LI-PO CHOU
*National Central University & National Taipei University of Technology,
Taiwan, ROC*

1. Introduction

This chapter designs an intelligent humanoid robot that not only can walk forward, backward, turn left, turn right, walk sideward, squat down, stand up and bow smoothly, but also can imitate several human basic motions. The robot's structure is composed of 17 AI motors with some self- design acrylic sheets connections. The robot is like a human in that it also has two hands, two feet, and a head. The head is a web camera which serves as its eye of the robot. The eye can recognize the color marks pasted on the human body in any complex background. The robot can recognize and imitate human motions according to the relative positions of those marks. The imitated human motions include the various motions of the hand and the lower body, such as "raise hand", "Stand up", "Squat down", and "Stand on one foot". Furthermore, the robot can also imitate "walking forward", "walking backward" and "walking sideways". The webcam automatically rotates to search the marks pasted on the human when they move outside the robot's vision. Notably, the stability and balance of the robot should be maintained, regardless of the motion performed by the robot.

Humanoid biped robots have been widely studied. Those investigations always focus on keeping balance control and walking as smoothly as possible. Zero Moment Point (ZMP) concept has been used to implement the balance control for the biped robot (Erbatur et al., 2002), (Kim & Oh, 2004) and (Park & Chung, 1999). The paper (Kanehiro et al., 1996) developed a walking pattern generator and a gravity compensation function to enable the biped robot to walk and carry objects. (Grizzle et al., 2001) established the existence of a periodic orbit in a simple biped robot, and analyzed its stability properties. A biped robot has been designed in (Loffler et al., 2004) to achieve a dynamically stable gait pattern, allowing for high walking velocities. A walk control for biped robots, consisting of a feed forward dynamic pattern and a feedback sensory reflex, has also been proposed in (Huang & Nakamura, 2005).

(Sias & Zheng, 1990) proposed the number of degrees of freedom corresponding to robot motions. For instance, each foot should have four degrees of freedom at least for the basic walking of a biped robot and should have five degrees of freedom at least for walking up stairs and down stairs. A robot can turn and walk smoothly on the ground with six degrees of freedom per foot, and can walk with a large step given seven degrees of freedom per foot. Furthermore, a robot needs at least eight degrees of freedom per foot to walk like a human being. The above information is helpful for the robot designers when determining the number of degrees of freedom of a robot.

Conversely, many papers have discussed the interaction motions between robots and humans. Motion imitation is one of the interaction motions. (Nakaoka et al., 2005) used eight cameras to detect and recognize 32 marks on a dancer body such that the robot can imitate Japanese dance motions. (Zhao et al., 2004) applied six cameras to detect and recognize 38 marks to allow a robot to imitate humans in playing “TaiChi” gong-fu. (Tanco et al., 2005) designed a robot that can imitate hand motions of humans in real time by recognizing the skin of human’s two hands. Moreover, a dance robot was developed in Japan in 2003 (Kosuge et al., 2003).

The organization of this chapter is as follow. Section 2 describes the mechanisms of the robot. Section 3 proposes the walking path planning method for the robot. Section 4 presents the motor torque control and timing arrangement for the robot. Section 5 describes the extraction of the markers pasted on the human’s body and the motion imitation for the robot. Some experiments for the humanoid robot are provided in Section 6. The conclusion is discussed in the final section.

2. Mechanisms of the robot

The humanoid biped robot designed in this study is composed of 17 AI motors (AI-1001 and AI-601) and some self design acrylic sheet connections. The robot is 40 cm tall, 23 cm wide and 1.5 kg weight and is shown in Fig. 2.1. Each foot of the robot has five degrees of freedom comprising two degrees of freedom in the hip, one in the knee and two in the ankle. Each hand has three degrees of freedom consisting of two degrees of freedom in the shoulder and one in the elbow. There is also a degree of freedom in the neck and a camera on the head to serve as an eye. The motor on the neck can rotate the camera up and down. All AI motors have different ID numbers and are connected in series as shown in Fig. 2.2. The motors in highing load positions, namely ID-1~ID-14, are AI-1001 motors which has a maximum torque of 10Kg/cm. The motors in low loading positions, namely ID-15~ID-17, are AI-601 motors which has a maximum 6Kg/cm torque.

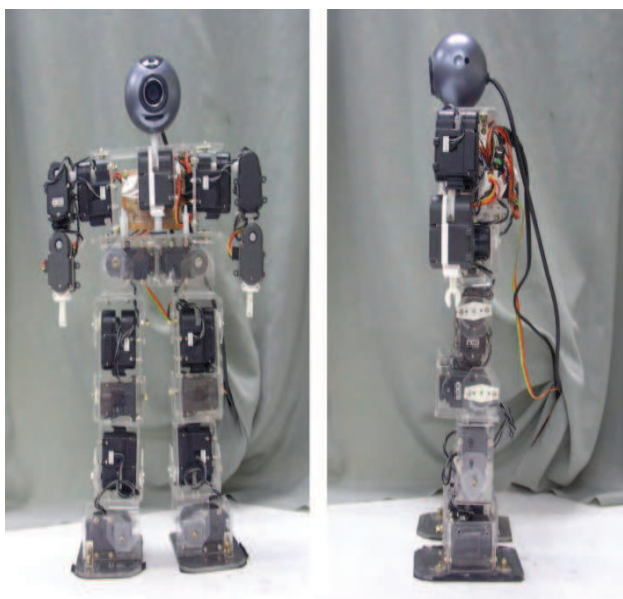

Fig. 2.1. The humanoid biped robot

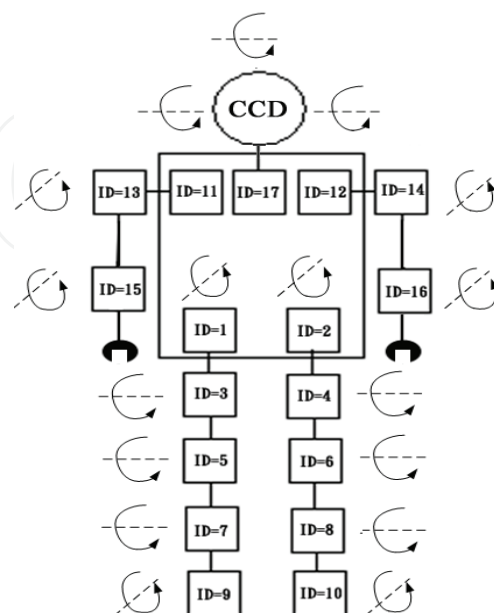

Fig. 2.2. All motors on the robot

The controller delivers command packets to the AI motor to control the motor actions. Those packets are the commands of Position Send, Position Read, Act Down, Power Down and 360° Rotation (see Fig. 2.3(a)). The motor returns response packets, containing the current and position data of the motor (see Fig. 2.3(b)), back to the controllers. The AI motor is connected to the personal computer (PC) via an RS-232 asynchronous serial communication link (Kim et al., 2000). The camera on the head of the robot is a webcam linked to the computer by USB 2.0 interface. The webcam can take 30 pictures/sec and has a resolution of 1280 × 960. Moreover, Borland C++ Builder 6.0 is used to develop a human-machine interface. In summary, the robot is controlled by a PC with a webcam and the communication of RS-232. All hardware framework connection of the robot system is shown in Fig. 2.4.

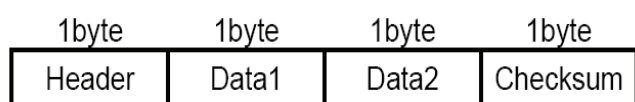

Fig. 2.3(a). The command packets

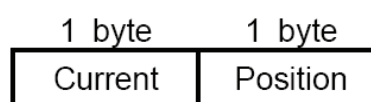

Fig. 2.3(b). The response command packets

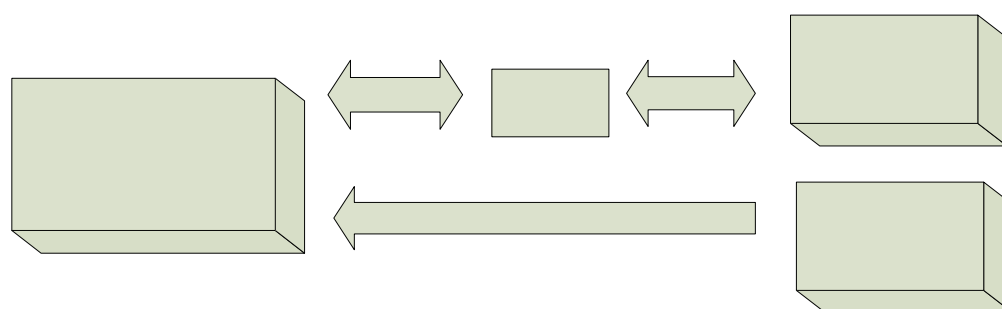

Fig. 2.4. The hardware framework connection of the robot system

3. Path planning for the basic walking

Walking path planning is important in ensuring that humanoid robot walks stably. Fig. 3.1 shows a walking path planning, namely the cycloid plan (Huang et al., 2001) & (Hodgins & Raibert, 1991)). In the figure, dotted lines denote the cycloid paths of the hip and the swinging ankle of a humanoid robot to perform a walking motion.

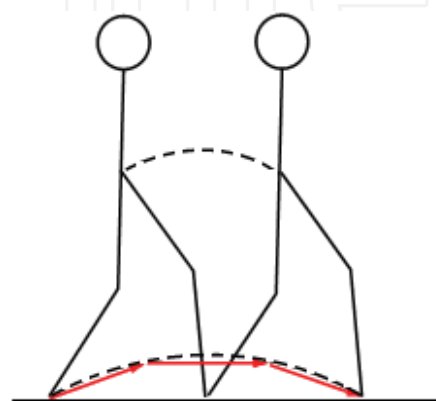

Fig. 3.1. The cycloid path

The cycloid paths shown in Fig. 3.2(a) can be obtained from equations in the papers (Hodgins & Raibert, 1991) and (Kurematsu et al., 1988). Any point on the cycloid paths can be solved from those equations and then the rotating angles of AI motors can be obtained by the inverse kinematics (Kim et al., 2000). However this approach is only suitable for walking and its calculation is very complicated. To simplify the calculation and design, the proposed method set four sampling points along a step path as shown by the gray points in Fig. 3.2(b). Further, one additional point (the white point in Fig. 3.2(b)) is added between the starting gray point and the second gray point to emphasize the smooth moving for the instant of off landing. These five sampling points are the reference points to establish the walking path.

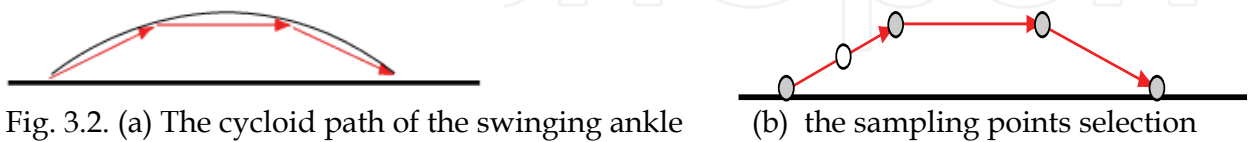

Fig. 3.2. (a) The cycloid path of the swinging ankle

(b) the sampling points selection

A walking path planning method is to construct a trajectory to be followed by the ankle or the hip. The next issue for the walking plan is to locate the center of gravity (COG). A basic walking motion of a robot can be divided into eight steps, in terms of the changes of COG:

Step 1: Stand with two feet; COG is between two feet.

Step 2: Move the COG onto the left (right) foot.

Step 3: Lift the right (left) foot and move forward.

Step 4: Land the right (left) foot on the ground.

Step 5: Move COG between two feet.

Step 6: Move COG on the right (left) foot.

Step 7: Lift the left foot and move forward.

Step 8: Land the left foot on the ground.

For a basic walking motion, the above eight steps can be seen as eight states. Fig. 3.3 is the series of walking motion, where the black point is the COG of the robot. The shifting of COG from Step 1 to Step 8 is presented in the figure. Fig. 3.4 shows the walking motion of a real humanoid robot.

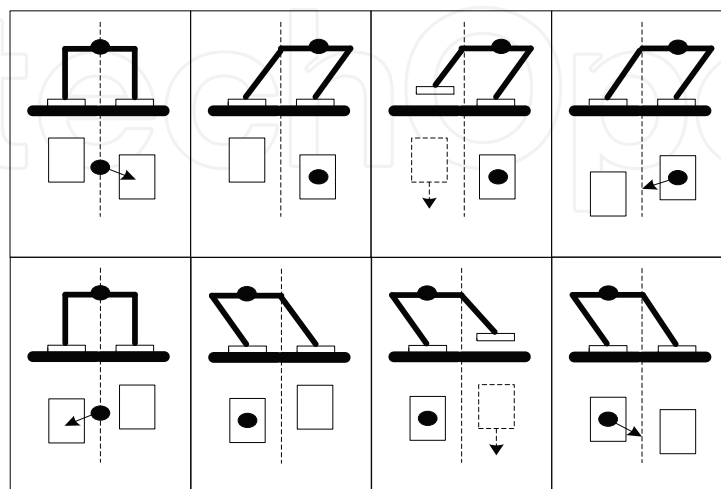

Fig. 3.3. A series of walking motions

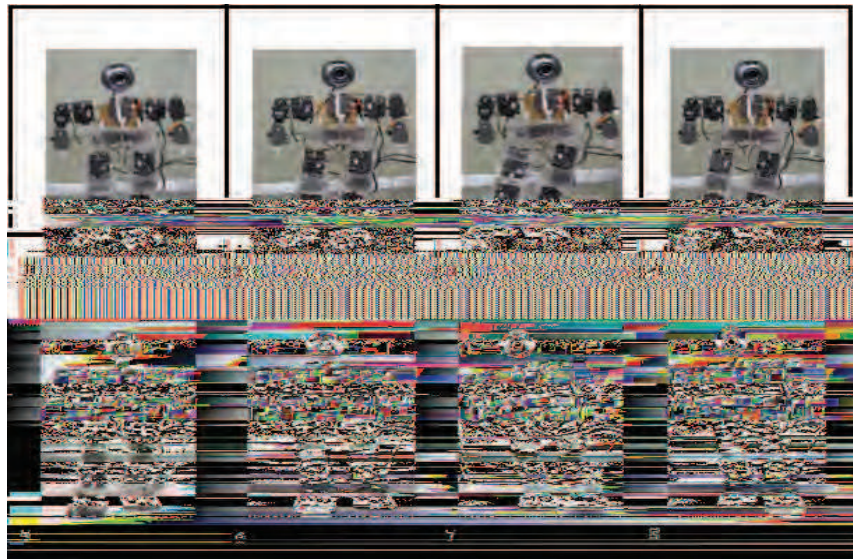

Fig. 3.4. Walking motions of a real humanoid robot

A humanoid robot walks following the above procedure. However, implementing these eight steps does not produce a smooth walking, since a motor with high torque that rotates a large degree directly and then generates an unpredictable inertia and momentum causing the robot to fall down or move unstably. Therefore, to improve the smoothness and stability of walking motion, the number of sample points between two successive states should be increased, ideally at least 10. Increasing the number of samples reduces inertia, thus enabling the robot to move smoothly and stably. However, the smoothness is ignored, if the robot needs additional momentum to achieve some motion at some instant (for instance, the instant of foot lifting off the ground). The number of samples can be reduced in this case. The above analysis for basic walking can also be applied to the other motions, such as stand up, squat down, hand up and down.

4. Motor torque control and timing arrangement

The torque control of each motor is also an issue when the robot is moving. The ankle always needs a large torque, because it has a very high loading. Furthermore, when the robot stands on one foot, the thigh needs a large torque too. In other words, each motor needs a proper torque corresponding to its motion. Therefore, each motor's torques should be properly given when the robot is performing a motion.

Additionally, the robot has many serially connected motors for which the timing arrangement is very important. It is known that the motor performing large degree rotation needs much more time than that motor performing small degree rotation. Therefore, time arrangement work is not only to arrange the order of motor operating, but also to set a certain delay time (waiting time) for the motor which performs small degree rotation such that the motor, which performs large degree rotation, can finish its operation before the next state starts.

After the moving path is planned and sample points are obtained, then the robot needs to follow the path and the sample points to move. Therefore, by trial and error, all proper data of the corresponding motors at each sample point are found and saved to perform the

motion. The data contain the rotation degree, torque magnitude, and operation time for each motor. In summary, a basic walking motion involves torque control, path planning and timing arrangement for the motor operations.

5. Motions recognition and imitation

Before imitating a human motion, the robot has to recognize the motions exhibited by the imitated human (called Mr. A) in this work. An experiment was performed in which some specific marks with red and yellow color were pasted on the body of Mr. A. Two yellow marks were pasted on the stomach (or body) and right foot of Mr. A; and three red marks are pasted on two hands and left foot as shown in Fig. 5.1(a). The following motions were imitated: motions of lower part of the body, namely stand up, squat down, and stand on a single foot; and the motions of the hands, namely hand up and down, both hands lifting evenly, and hand curving. Sideways movement was also performed.

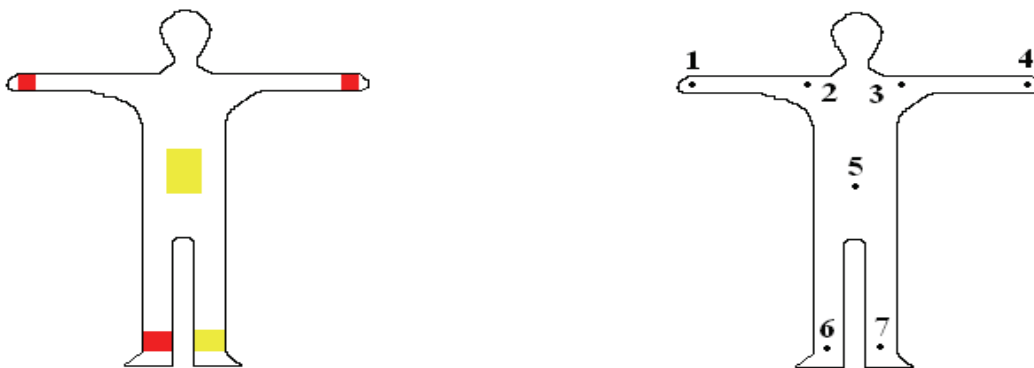

Fig. 5.1. (a) The five color marks

(b). Seven key points

First, let us introduce the following procedure to get the seven key points of Mr. A.

Step 1: Capture the image of Mr. A with 320×240 pixels by robot's head camera.

Step 2: Transform RGB color model of the image to YUV color mode to reduce the effect of changes in brightness.

Step 3: Detect the five color marks on the body of Mr. A and calculate the center of each mark.

Step 4: Identify the given key points from the relative locations of five color marks on the body of Mr. A. These points are the stomach (or body), left hand, right hand, left foot and right foot.

Step 5: Based on the five key points in step 4, estimate the other two key points, left and right shoulders (see Fig. 5.1(b)).

Now let the coordinates of seven key points be shown in Table 5.1 and the motions of Mr. A as shown in Fig. 5.2 be imitated.

Positions	left hand	right hand	left foot	right foot	left shoulder	right shoulder	Stomach (body)
Notations	(x_{lh}, y_{lh})	(x_{rh}, y_{rh})	(x_{lf}, y_{lf})	(x_{rf}, y_{rf})	(x_{ls}, y_{ls})	(x_{rs}, y_{rs})	(x_b, y_b)

Table 5.1 Notations of seven key points

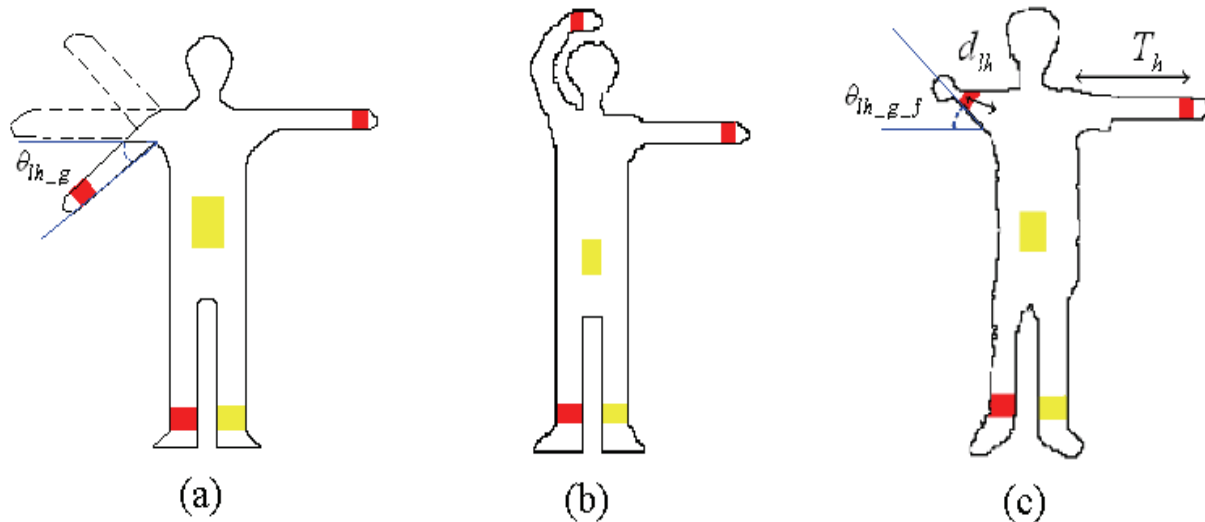

Fig. 5.2. (a) Hand up, down and lifting sideward; (b) Hand up and curving ; (c) Hand lifting forward.

The motions of Mr. A’s hands in Fig. 5.2 can be recognized by the equations in the table.

Conditions	θ_{lh_g} or $\theta_{lh_g_f}$	Motions
$x_{lh} < x_{ls}$	$\theta_{lh_g} = \tan^{-1} \left(\frac{y_{ls} - y_{lh}}{x_{ls} - x_{lh}} \right)$	Hand up, down and lifting sideways
$x_{ls} < x_{lh} \ \& \ y_{lh} < y_{la}$	$\theta_{lh_g} = \tan^{-1} \left(\frac{y_{ls} - y_{lh}}{x_{ls} - x_{lh}} \right)$	Hand up and curving
$d_{lh} < T_h$	$\theta_{lh_g_f} = \cos^{-1} \left(\frac{d_{lh}}{T_h} \right)$	Hand lifting forward

Table 5.2. Conditions of hands’ motions

where θ_{lh_g} and $\theta_{lh_g_f}$ are the angles that left hand lifts sideways and forward, respectively. d_{lhs} and d_{rhs} are the distance from the left hand to left shoulder and from the right hand to right shoulder, respectively, where T_h is a threshold and d_{lhs} is defined as

$$d_{lhs} = ((x_{ls} - x_{lh})^2 + (y_{ls} - y_{lh})^2)^{1/2} \tag{1}$$

The motions of right hand can be figured out similarly.

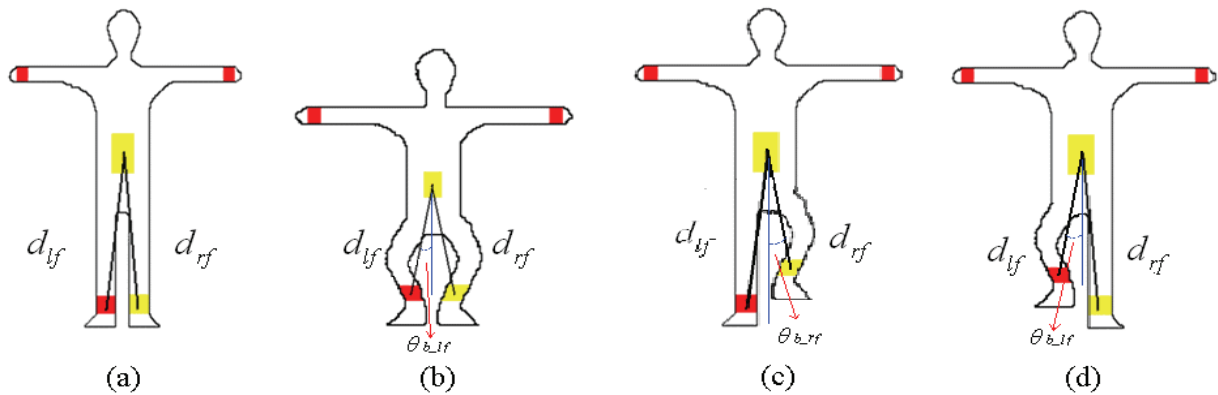

Fig. 5.3. (a) Stand up; (b) Squat down; (c) Stand on the left foot ; (d) Stand on the right foot.

The motions of Mr. A's feet as shown in Fig. 5.3 can be recognized by the equations in the following table.

Conditions	θ_{b_lf}	Motions
$d_{lf} > T_f \ \& \ d_{rf} > T_f$	$\theta_{b_lf} = \tan^{-1}\left(\frac{x_b - x_{lf}}{y_b - y_{lf}}\right)$ and $\Delta d = 0$	Stand up
$d_{lf} < T_f \ \& \ d_{rf} < T_f$	$\theta_{b_lf} = \tan^{-1}\left(\frac{x_b - x_{lf}}{y_b - y_{lf}}\right)$ and $\Delta d = 0$	Squat down
$d_{lf} > T_f \ \& \ d_{rf} < T_f$	$\theta_{b_rf} = \tan^{-1}\left(\frac{x_{rf} - x_b}{y_b - y_{rf}}\right)$ and $\Delta d = T_f - d_{rf}$	Stand on the left foot only
$d_{lf} < T_f \ \& \ d_{rf} > T_f$	$\theta_{b_lf} = \tan^{-1}\left(\frac{x_b - x_{lf}}{y_b - y_{lf}}\right)$ and $\Delta d = T_f - d_{lf}$	Stand on the right foot only

Table 5.3. Conditions of feet's motions

where θ_{b_lf} is the angle between body and the left foot, d_{lf} and d_{rf} are defined as follows:

$$\begin{aligned} d_{lf} &= ((x_b - x_{lf})^2 + (y_b - y_{lf})^2)^{1/2} \\ d_{rf} &= ((x_b - x_{rf})^2 + (y_b - y_{rf})^2)^{1/2} \end{aligned} \quad (2)$$

d_{lf} and d_{rf} are the distances from left foot to the body and right foot to the body, respectively. T_f is a threshold defined by the designer and $\Delta d = T_f - d_{lf}$ (or $\Delta d = T_f - d_{rf}$) is the height of one foot lifting. When Δd is large, that means the robot lifts one foot highly. When the robot recognizes the motions of human, then the robot should imitate those motions. However, the robot should also be able to switch smoothly from one motion to another motion. Fig. 5.4 shows a finite state machine representing the motion switching paths of the lower part of the robot's body.

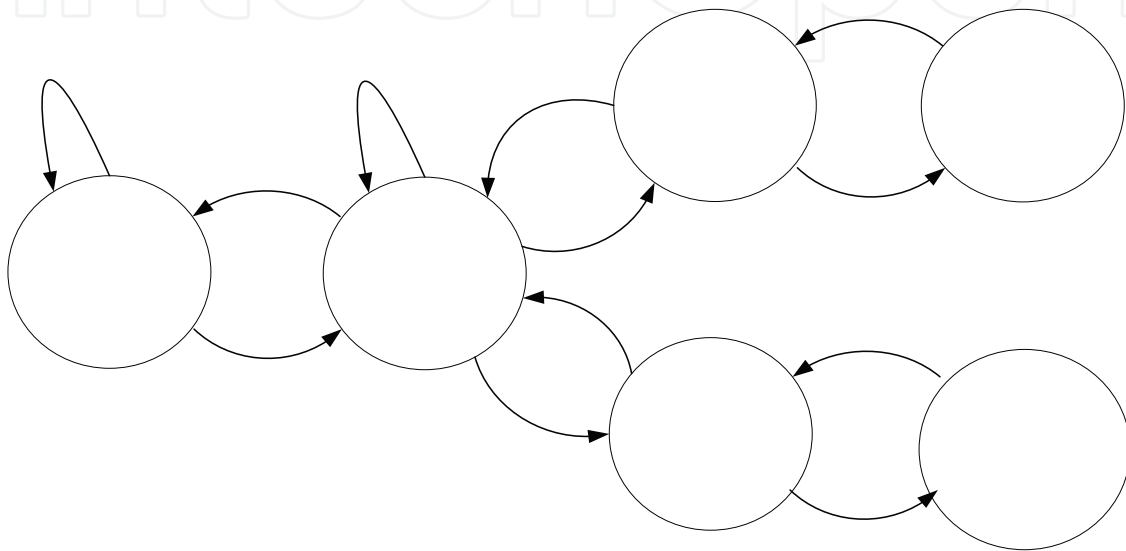

Fig. 5.4. Finite state machine for the switching of the robot's motions

For instance, suppose the robot stands on two feet initially (status 0). If the robot detects that Mr. A squate down, then it follows path 9 causing its status to change to status 5. If the robot then detect Mr. A stands on two feet again, then it follows path 10 to change its status to status 0 again. The robot can thus switch from status to status by following the corresponding path. Here, each path is planned in advance by following the method of Section 3.

The motions of moving sideways, forward and backward are now discussed. Since there is a yellow mark pasted on the body of Mr. A, the distance between the next and current locations of the mark's center can be adopted to recognize him moving sideways. For instance, $x_b(t+1) - x_b(t) < -T_b$ means Mr. A is moving left-ward; and $x_b(t+1) - x_b(t) > T_b$ means Mr. A is moving right-ward, where $x_b(t+1)$ and $x_b(t)$ are the next and current positions, respectively, of the yellow mark's center; further, T_b is a threshold. On the other hand, Mr. A moving forward or backward is recognized by the perceived size of the yellow mark on his body. If the mark looks smaller by the webcam of the robot at current status than at his previous status, then Mr. A moves backward. Conversely, if the mark appears larger at the current status than at the previous status, then Mr. A is moving forward.

Path 11

6. Experiment results

This section presents motion experiments for a humanoid robot. Part A presents some basic motions of a humanoid robot, namely walking forward and backward, turning right or left, moving sideways, squat down, stand up and bow. Part B presents the motion imitations of the robot. Data figures, photographs and detailed descriptions are presented in these two parts. Because the humanoid robot and the human face each other, the photographs are opposite to each other. For example, if Mr. A raises his right hand, the humanoid robot raises its left hand.

Part A: Basic motions

By using the path planning introduced in section 3, the humanoid robot practices the motions of forward, backward, turn right, turn left, stand up and squat down. For instance, Fig. 6.1 shows a series of pictures of two basic motions walking forward for two steps. Fig. 6.2 shows the motions of squatting down and standing up. The above six motions can be finished smoothly and stably following the path planning.

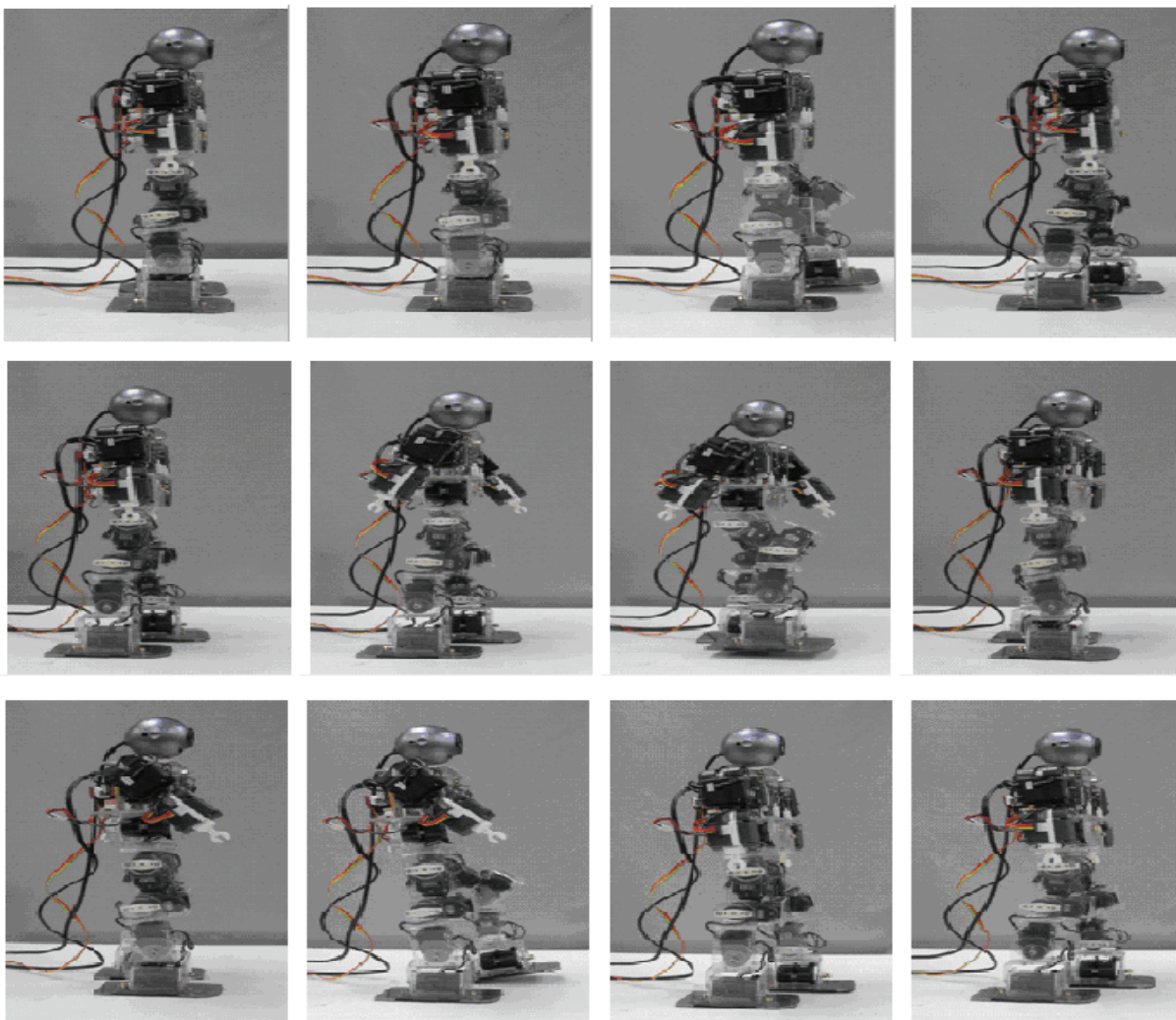

Fig. 6.1. A series of pictures of walking forward for the robot

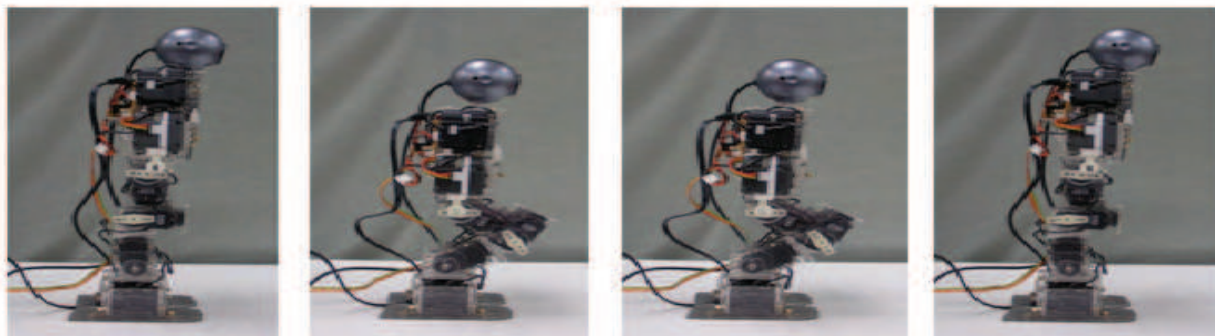

Fig. 6.2. The motions of squatting down and standing up

Part B: Motion imitation

The motions to be imitated in part B are hand up and down, hand lifting sideways, hand up and curving, and hand lifting forward. For instance, Fig. 6.3 shows a series of figures in which the robot's left hand is down initially and lifts sideways from the 1.7th second to the 3.3th second, and then puts down again at the 4.5th second. The left hand lifts again from the 5th second and keeps lifting from the 6th second to the 7.5th second and down at the 8th second. From Fig. 6.4, the humanoid robot is standing on two feet for the initial 7 seconds, standing on the right foot only during 7 -10 seconds, and standing on the left foot only during 15 -21 seconds; and then the robot squats down during 24 - 28 seconds and returns to stand on two feet after the 28th second. Experiment results indicate that the humanoid robot can switch its status when Mr. A changes his motions. Fig. 6.5 shows a series of pictures for several motion imitations, in which the humanoid robot imitate Mr. A's motions very well.

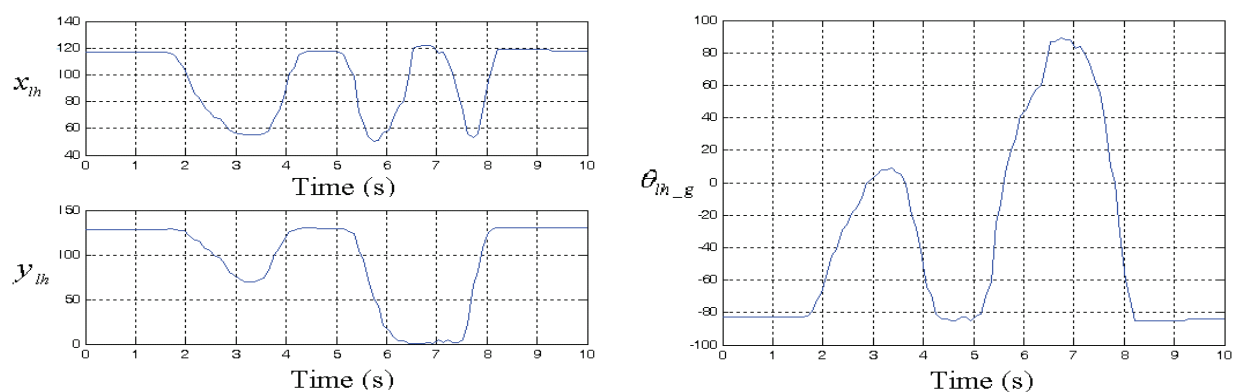

Fig. 6.3. A series of figures for the left hand lifting.

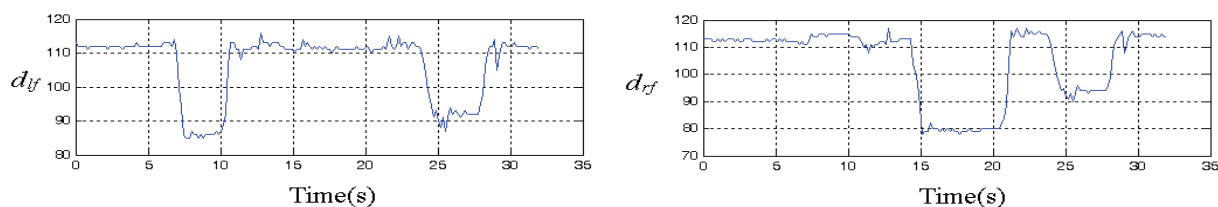
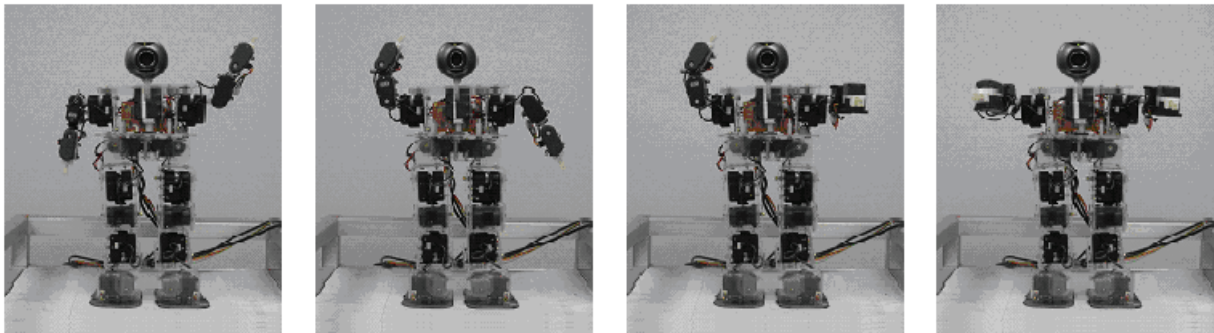
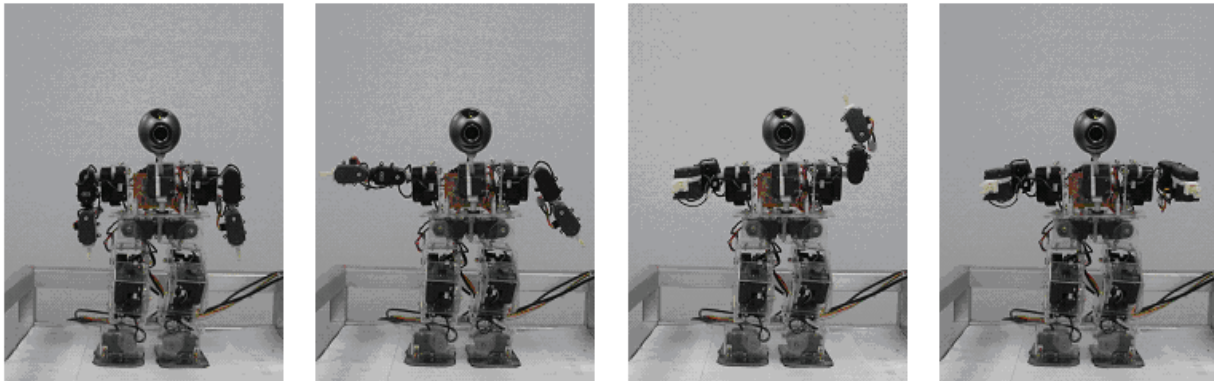
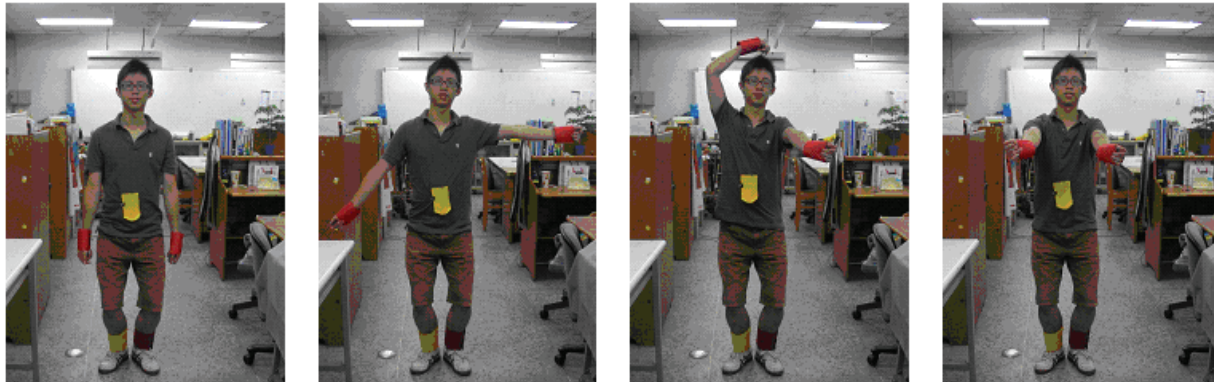

Fig. 6.4 The distances from the left foot and the right foot to the body.



(a)



(b)

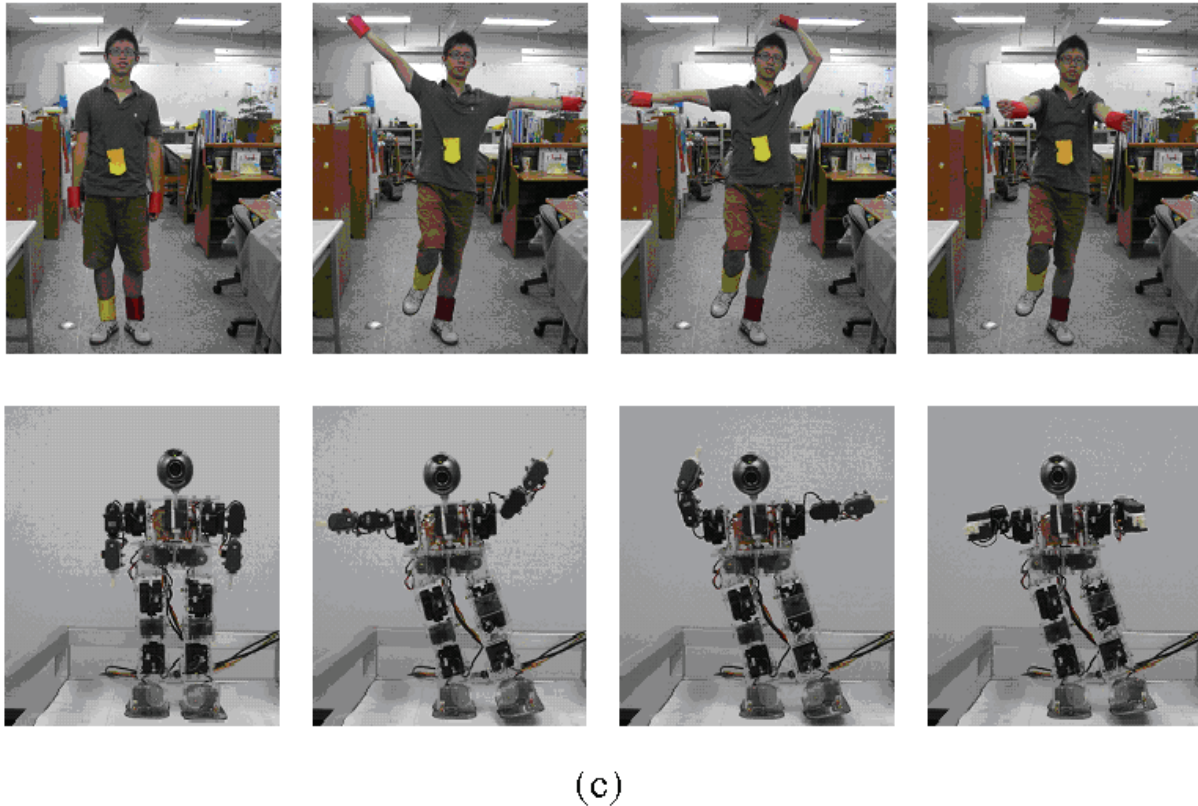

Fig. 6.5 Motion imitations (a) hand up, down, curving and lifting sideways; (b) squatting down; (c) Standing on one foot.

7. Conclusion

This chapter has proposed a scheme by which a humanoid robot can perform basic motions, and can imitate some human motions. The basic motions consist of walking forward, walking backward, turning left, turning right, walking sideways, squatting down, standing up and bowing. The imitated motions are hands up and down, squatting down, standing up, hand lifting sideways, hand up and curving, and hand lifting forward. The designed humanoid robot comprises 17 AI motors and one camera, and is controlled by a PC. The robot control strategy includes motion path planning, torque control, and timing arrangement. The experiments show that the robot works very well in both basic and imitated motions.

8. Reference

- Erbatur, K.; Okazaki, A.; Obiya, K.; Takahashi, T. & Kawamura, A. (2002). A study on the zero moment point measurement for biped walking robots, *Proceedings of International Workshop on Advanced Motion Control*, pp. 431–436, Jul. 2002
- Grizzle, J. W.; Abba, G. & Plestan, F. (2001). Asymptotically Stable Walking for Biped Robots: Analysis via Systems with Impulse Effects, *IEEE Transactions on automatic control*, Vol. 46, Jan. 2001 pp. 51 - 64, 0018-9286

- Hodgins, J. K. & Raibert, M. H. (1991). Adjusting step length for rough terrain locomotion, *IEEE Transactions on Robotic and Automation*, Vol. 7, Jun. 1991 pp. 289–298, 1042-296X
- Huang, Q. & Nakamura, Y. (2005). Sensory reflex control for humanoid walking, *IEEE Transactions on Robotic and Automation*, Vol. 21, Issue 5, Oct. 2005 pp. 977–984, 1552-3098
- Huang, Q.; Yokoi, K. ; Kajita, S.; Kaneko, K.; Arai, H.; Koyachi, N. & Tanie, K. (2001). Planning Walking Patterns for a Biped Robot, *IEEE Transactions on Robotic and Automation*, Vol. 17, No. 3, Jun. 2001 pp. 280- 289, 1042-296X
- Kanehiro, F.; Inaba, M. & Inoue, H. (1996). Development of a two-armed bipedal robot that can walk and carry objects, *Proceedings of IEEE/RSJ International conference on Intelligent Robots and Systems*, Vol.1, pp. 23–28, 1996
- Kim, D. J.; Kim, K. I.; Zheng, Y. F.; Sun, Z. & Sun F. (2000). Design of Small Power Biped Robot by Load Sharing of Walking Gait, *Proceedings of IEEE International conference on Robotics and Automation*, Vol. 4, pp. 3359–3364, Apr. 2000
- Kim, J. H. & Oh, J. H. (2004). Walking control of the humanoid platform KHR-1 based on torque feedback control, *Proceedings of IEEE International conference on Robotics and Automation*, Vol. 1, pp. 623–628, 2004
- Kosuge, K.; Hayashi, T.; Hirata, Y. & Tobiyama, R. (2003). Dance partner robot - Ms DanceR, *Proceedings of IEEE/RSJ International conference on Intelligent Robots and Systems*, Vol. 3, pp. 3459-3464, 2003
- Kurematsu, Y.; Kitamura, S. & Kondo, Y. (1988). Trajectory Planning and Control of a Biped Locomotive Robot-Simulation and Experiment, *Robotics and Manufacturing, Recent Trends in Research, Education and Applications*, M.Jamshidi(ed.), pp.65-72, ASME Press, 1988
- Loffler, K.; Gienger, M.; Pfeiffer, F. & Ulbrich, H. (2004). Sensors and control concept of a biped robot, *IEEE Transactions on Industrial Electronics.*, Vol. 51, Oct. 2004 pp. 972-980, 0278-0046
- Nakaoka, S.; Nakazawa, A.; Kanehiro, F.; Kaneko, K.; Morisawa, M. & Ikeuchi, K. (2005). Task model of lower body motion for a biped humanoid robot to imitate human dances?, *Proceedings of IEEE/RSJ International conference on Intelligent Robots and Systems*, pp. 3157–3162, 2005
- Park, J. H. & Chung, H. (1999). ZMP compensation by online trajectory generation for biped robots, *Proceedings of IEEE International conference on Systems, Man, and Cybernetics*, Vol. 4, pp. 960–965, 1999
- Sias, F. R.; Jr. & Zheng, Y. F. (1990). How Many Degrees-of-Freedom Does a Biped Need?, *Proceedings of IEEE International Workshop on Intelligent Robots and Systems*, Vol. 1, pp. 297–302, Jul. 1990
- Tanco, L.; Bandera, J. P.; Marfil, R. & Sandoval, F. (2005). Real-time human motion analysis for human-robot interaction, *Proceedings of IEEE/RSJ International conference on Intelligent Robots and Systems*, pp. 1402–1407, 2005
- Zhao, X. J.; Huang, O.; Peng, Z. & Li, K. (2004). Kinematics mapping and similarity evaluation of humanoid motion based on human motion capture, *Proceedings of IEEE/RSJ International conference on Intelligent Robots and Systems*, vol.1, pp. 840–845, 2004

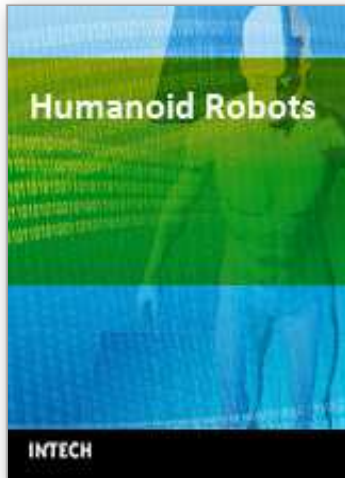

Humanoid Robots

Edited by Ben Choi

ISBN 978-953-7619-44-2

Hard cover, 388 pages

Publisher InTech

Published online 01, January, 2009

Published in print edition January, 2009

Humanoid robots are developed to use the infrastructures designed for humans, to ease the interactions with humans, and to help the integrations into human societies. The developments of humanoid robots proceed from building individual robots to establishing societies of robots working alongside with humans. This book addresses the problems of constructing a humanoid body and mind from generating walk patterns and balance maintenance to encoding and specifying humanoid motions and the control of eye and head movements for focusing attention on moving objects. It provides methods for learning motor skills and for language acquisition and describes how to generate facial movements for expressing various emotions and provides methods for decision making and planning. This book discusses the leading researches and challenges in building humanoid robots in order to prepare for the near future when human societies will be advanced by using humanoid robots.

How to reference

In order to correctly reference this scholarly work, feel free to copy and paste the following:

Wen-June Wang and Li-Po Chou (2009). Humanoid Robot With Imitation Ability, Humanoid Robots, Ben Choi (Ed.), ISBN: 978-953-7619-44-2, InTech, Available from:

http://www.intechopen.com/books/humanoid_robots/humanoid_robot_with_imitation_ability

INTECH
open science | open minds

InTech Europe

University Campus STeP Ri
Slavka Krautzeka 83/A
51000 Rijeka, Croatia
Phone: +385 (51) 770 447
Fax: +385 (51) 686 166
www.intechopen.com

InTech China

Unit 405, Office Block, Hotel Equatorial Shanghai
No.65, Yan An Road (West), Shanghai, 200040, China
中国上海市延安西路65号上海国际贵都大饭店办公楼405单元
Phone: +86-21-62489820
Fax: +86-21-62489821

© 2009 The Author(s). Licensee IntechOpen. This chapter is distributed under the terms of the [Creative Commons Attribution-NonCommercial-ShareAlike-3.0 License](https://creativecommons.org/licenses/by-nc-sa/3.0/), which permits use, distribution and reproduction for non-commercial purposes, provided the original is properly cited and derivative works building on this content are distributed under the same license.

IntechOpen

IntechOpen