

We are IntechOpen, the world's leading publisher of Open Access books Built by scientists, for scientists

4,800

Open access books available

122,000

International authors and editors

135M

Downloads

Our authors are among the

154

Countries delivered to

TOP 1%

most cited scientists

12.2%

Contributors from top 500 universities



WEB OF SCIENCE™

Selection of our books indexed in the Book Citation Index
in Web of Science™ Core Collection (BKCI)

Interested in publishing with us?
Contact book.department@intechopen.com

Numbers displayed above are based on latest data collected.
For more information visit www.intechopen.com



Fundamentals of Underwater Vehicle Hardware and Their Applications

Hiroshi Yoshida

Japan Agency for Marine-Earth Science and Technology
Japan

1. Introduction

The evolution of electrical and electronic engineering technology including nanotechnology over the last several years has led to improvements in the development of mobile underwater platforms or autonomous underwater vehicles (AUVs) enabling them to go where tethered vehicles or manned vehicles have trouble reaching, such as under the ice, other dangerous zones, and into the deepest depths. In order to survey the whole ocean efficiently, the development of intelligent underwater vehicles will be one necessary solution. For the development of practical intelligent underwater vehicles, designers need cutting-edge fundamental devices incorporated into advanced underwater vehicles. Over the past ten years, the underwater research and development team to which the author belongs has developed five custom-made underwater vehicles: *Urashima* (Aoki 2001 & 2008), *UROV7k* (Murashma 2004), *MR-X1* (Yoshida 2004), *PICASSO*, and *ABISMO*.

Urashima is the prototype vehicle of a long cruising range AUV (LCAUV) powered by the hybrid power source of a lithium-ion battery and a fuel cell. *Urashima* autonomously travelled over 300 km for about 60 hours in 2005. The LCAUV aims to make surveys under the arctic ice possible for distances of over 3000 km. The *UROV7k* is a tether cable-less ROV, having its power source in its body like an AUV. The *UROV7k* was designed to dive up to 7000 m without large on-board equipment such as a cable winch, a traction winch or a power generator. The *MR-X1* is a middle-size prototype AUV for the test of modern control methods and new hardware and for the development of new mission algorithms. The plankton survey system development project named Plankton Investigatory Collaborating Survey System Operon (*PICASSO*) project at the Japan Agency for Marine-earth Science and TEChnology (JAMSTEC) aims to establish a multiple vehicle observation system for efficient and innovative research on plankton. By using the ROV *Kaiko*, which was the deepest diving ROV in the world, a number of novel bacteria were found from mud samples taken in the Challenger Deep in the Mariana Trench (Takai, 1999). However, the lower vehicle of the *KAIKO* system was lost when the secondary tether was sheared (Watanabe 2004). The most important goal of the *ABISMO* system is to obtain mud samples from the Challenger Deep in the Mariana Trench, because scientists still want uninterrupted access to the deepest parts of the oceans using a vehicle equipped with sediment samplers. *ABISMO* consists of a sampling station and a sediment probe. The station contains two types of bottom samplers. One launches the probe to make a preliminary survey, launching the sampler to obtain a sample.

Source: Underwater Vehicles, Book edited by: Alexander V. Inzartsev,
ISBN 978-953-7619-49-7, pp. 582, December 2008, I-Tech, Vienna, Austria

Through the development of these vehicles, many improvements in fundamental devices for underwater vehicles were made. In this chapter, firstly, hardware information on the key devices needed to make cutting edge intelligent underwater vehicles are described. These include new original devices: a small electrical-optical hybrid communication system, an HDTV optical communication system, an inertial navigation system, buoyancy material for the deepest depths, a thin cable with high-tensile strength, a USBL system, a broadcast class HDTV camera system, an HDTV stereoscopic system, a high capacity lithium ion battery, a high efficiency closed-cycle PEM fuel cell, and a prototype of an underwater electromagnetic communication system. In the third section, we present attempts made for data processing methods for autonomous control of underwater vehicles. Finally, the details of the AUVs using the above-mentioned devices are given, including some of the sea trial results.

2. Underwater vehicle hardware

2.1 Categories of unmanned underwater vehicles and their basic device components

Remotely operated vehicles (ROVs) and autonomous underwater vehicles (AUVs) are well-known kinds of underwater vehicles. Recently, there are also newer categories of underwater vehicles, untethered ROVs (UROVs) and hybrid ROVs (HROVs). UROVs (Aoki et al., 1992) have the feature that the vehicle is only connected to its support ship via a long thin optical fiber cable. The vehicle of an UROV system has its own power supply, in the form of batteries - much like an AUV. An operator controls the vehicle in real-time and has access to high quality real-time video images using high data rate optical communication tools. UROVs have both the advantages of ROVs and AUVs. An HROV (Bowen et al., 2004), one of which is under development at the Woods Hole Oceanographic Institution, is a single vehicle that can perform two different, but related, missions. It refers to the vehicle's ability to do scientific research while tethered to the ship, and also while swimming freely. Traditionally, a separate vehicle is used to conduct long range surveys, while another vehicle performs the close-up work and sampling. The HROV will simply transform between its two modes of operation to accomplish both of these tasks. In this section, cutting edge basic devices, except for those devices used for controlling vehicles and power sources, are described.

a. Buoyancy Materials and Cables

These are fundamental devices for underwater vehicles. In extreme environments, such as in the deepest depths, a developer should use special devices to match the mission. Full depth buoyancy materials have been commercialized but they have never actually been used in real situations at full ocean depth. The HROV project group at WHOI has chosen SeaSpheres, produced by Deepsea Power & Light, as an alternative to syntactic foams made from micro glass balloons. JAMSTEC has developed a new buoyancy material usable at full ocean depth. The prototype was used in the ABISMO system and it successfully withstood a 10,300 m depth deployment in 2008. The specifications of the prototype are a crush pressure of 56 MPa and a specific gravity of 0.63.

Tether cables for underwater vehicles are also a key device for successful development. Many companies have produced underwater cables, except for cables rated for full depth. Kyo (Kyo 1999) used a Kevlar fiber cable for the full depth vehicle *Kaiko*, but it was broken during retrieval of the *Kaiko* vehicle in the face of an approaching typhoon (Watanabe 2004). JAMSTEC thus started the development of a new cable using para-aramid fiber with a

tensile strength of 350kg/mm² in 2005. This rod type aramid fiber does not concentrate stress. The cable (ϕ 20 mm x 160 m) consists of this aramid fiber, two coaxial cables, four single wire cables for power lines, cable sheath, and resin. The cable is covered in polypropylene. Specific gravity of the cable is around 1.3 and rupture strength is about 70 kN.

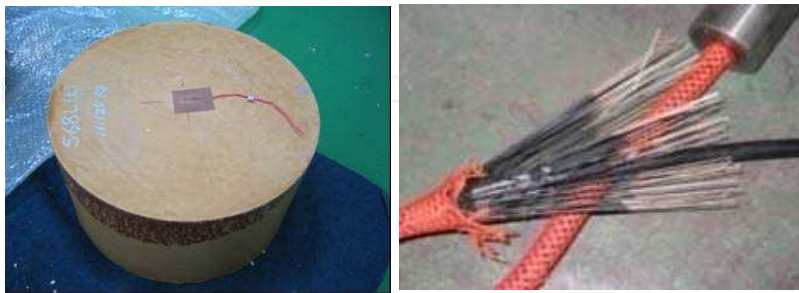

Fig. 1. A prototype of the full ocean depth buoyancy material (left) and the secondary cable made from para-aramid fiber (right).

Thin fiber optic cable and spoolers are used for UROV and HROV systems. Traditional ϕ 0.9 mm single mode fiber (Murashima 2004) or thinner fiber cable (Young 2006) is practically used for underwater vehicles.

b. Lights and Cameras

For the observation of marine organisms, seafloor geology and underwater object recognition, the selection and arrangement of lights and cameras are important. The popularity of high definition television (HDTV) cameras and LED lights are causing an increase in availability of underwater video. In addition to high quality camera imaging, there are holographic cameras, laser scanning systems, acoustic imaging systems and so on. Further information on these imaging systems has been reviewed by Kocak et al. (2008).

The underwater vehicle *PICASSO*, developed by JAMSTEC (Yoshida 2007), is equipped with a broadcast quality HDTV camera. This high resolution, high sensitivity camera enables precise observation of plankton beyond that which was possible with traditional NTSC cameras. The increase in resolution means animals can be identified to species rather than genus or simply family in some cases. JAMSTEC has developed an original wideband optical communication system with five interfaces: one HD-SDI, three NTSCs, four RS-232Cs, two RS-485s, and 8-channel parallel I/O for the vehicle. This system will be discussed later. They installed SONY's compact high definition camera system, HDC-X300K, and an original camera control board with a CAN interface into an aluminum pressure hull. A special coaxial underwater cable with pressure-tight SMB type RF connectors was made for connecting between pressure hulls. HDC-X300 has the following specifications: effective pixels 1440×1080, sensitivity of 2000 lx @ F10, minimum luminance of 0.003 lx @ F1.4, smear level of -120 dB, and signal to noise ratio of 52 dB. Its image sensor system consists of three 1/2" 1.5M-pixel CCDs. Remote control of the focus, iris, and zoom of this camera via the original control board is possible. The HD-SDI output signal the camera is directly transmitted to an on-board system as an optical modulation signal via the optical communication system. The HD-SDI signal, demodulated and output from the on-board system, is connected to both of an HDCAM recorder and an HDTV display. Any movie subjects are lighted using HID lamps (three custom 30 watt lamps diverted from car use) and/or handmade 20 watts LED array lights. Examples of captured HDTV images obtained by *PICASSO* are shown in Figure 2.



Fig. 2. An examples of an HDTV images taken by *PICASSO-1*. In this picture, the sponge and crabs are illuminated by a single HID lamp (left).

High power white LEDs, originally developed by Nichia corporation, have become widely used. Many underwater device makers produce underwater LED lights but they may be expensive. A low cost LED array in an oil-filled pressure balanced case is available to use to 11000 m depth. This consists of LEDs, a copper base plate, resistors, an underwater connector, and a 1/2" clear tube (Yoshida 2007b).

c. Stereoscopic HDTV Camera System.

Three-dimensional (3-D) television is one application for a stereoscopic camera system. 3-D television would make an effective operation environment for vehicle operators and viewers. There are lots of commercial software and hardware solutions to make and display 3-D images on a television display and a television screen. Miracube C190x produced by PAVONINE INC. for presentations aimed at small groups employs a 3-D expression method called the Parallax Barrier (Meacham, 1986.). This method doesn't need the observer to wear special glasses but only a single user can enjoy 3D vision and only from certain positions. Use of commercial projector systems for 3-D vision uses shutter glasses or polarizer glasses for users. The use of HDTV cameras for 3-D television gives the audience a more realistic experience. The *PICASSO-1* vehicle has the capability to deploy a stereoscopic HDTV camera system. The configuration of the camera system is shown in Figure 3. The major part of the system consists of two pressure-tight HDTV cameras (HDR-SR7 made by SONY) and a controller. Each aluminum pressure hull ($\phi 170\text{mm} \times 390\text{ mm}$; 9 kilograms in air; depth rating of 4,000 meters; acrylic window) includes an HDTV camera, an interface

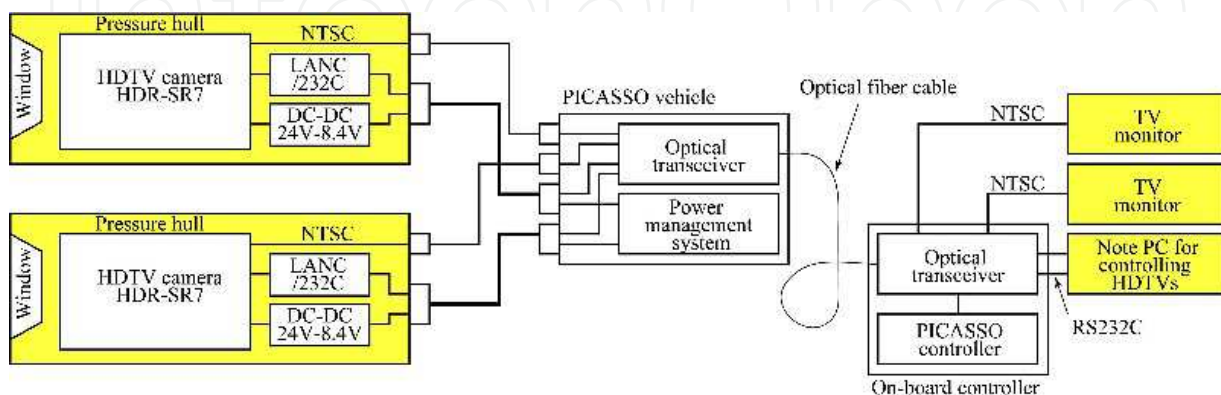

Fig. 3. System configuration of the stereoscopic high definition television camera system installed in the *PICASSO-1* system.



Fig. 4. *PICASSO-1* equipped with the stereoscopic HDTV camera system. Two LED light arrays were additionally made for this system and installed on either side.

adaptor, and a DC-DC converter. HDTV images (MPEG4 AVC/H.264) are locally recorded on the internal 60GB hard disk of the HDR-SR7. Figure 4 shows a snap shot of the *PICASSO-1* vehicle equipped with this stereoscopic HDTV camera system.

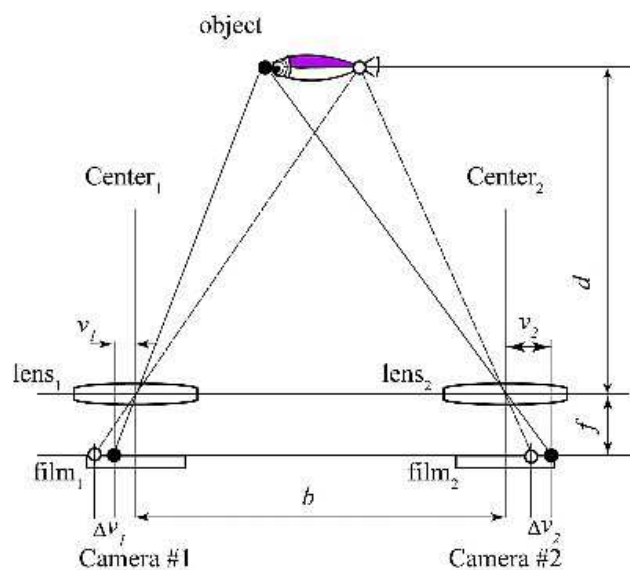

Fig. 5. Camera placement and coordinate system for stereovision.

The other application for the stereoscopic camera system is as an object scale estimation system. By using HDTV cameras for scale estimation, the resolution of the system become threefold compared with a conventional NTSC-based camera system. For measuring the distance to an object and estimating its size using stereovision, triangulation is generally used. In this method a disparity map is prepared. The disparity map is a depth map where the depth information is derived from offset images of the same scene. Figure 5 shows the coordinate system of the camera system for calculation. The disparity (d) between the left and right image points is defined as the difference between v_2 and v_1 . The depth; D is calculated from equation 1,

$$D = \frac{bf}{d} \quad (1)$$

Where b , f , and d denote base offset, focal length of camera (distance between lens and film), and disparity, respectively. Object size; S is roughly estimated from equation 2,

$$s = \frac{b}{2d}(\Delta v_1 + \Delta v_2) \quad (2)$$

In this equation, Δv_1 and Δv_2 are the image size on each film. To measure disparity in the camera system, we compute a given pixel location in either the right or left image coordinate frame with a stereo matching technique. Zitnick and Kanade (Zitnick & Kanade, 1999) have developed a better stereo algorithm. For calculation in real time using high definition images, a very high performance computer would be needed, so this calculation will be done after a dive has finished.

d. Inertial Navigation System (INS)

An INS is one of the most important devices for an AUV because an AUV must obtain an accurate position and information on any attitude changes itself. IXSEA's Phins, which is an INS based on a fiber optic gyroscope having a pure inertial position accuracy of 0.6 NM/hour, is widely used with a Doppler velocity log (DVL) in AUVs. A sufficient level of position accuracy is achieved by the aid of an external sensor, a ground referenced DVL. Larsen reported (Larsen 2002) that the Doppler-inertia based dead-reckoning navigation system, MARPOS, has a proven accuracy of 0.1 per cent of the distance traveled for straight-line trajectories. If an AUV equipped with an INS/DVL hybrid system cruises at a high altitude from a seafloor, a DVL cannot measure its velocity. This leads to increase of positioning error. To reduce this error an AUV usually requires an acoustic navigation system and operators set acoustic transponders in underwater positions before deployment of the AUV. In the case of longer range AUV operations, the time period of AUV navigation using pure inertial positioning data becomes long and this means that many transponders must be deployed – usually an untenable solution. From this point of view an INS should have the highest pure inertial position accuracy possible. Ishibashi *et. al.* have proposed a unique error reducing technique based on a ring laser gyro (Ishibashi 2008). The position error of an INS results from its drift-bias errors, the sources of which are unidentified random noises. They have proposed a method where the axial rotational motion is applied to the INS. They were able to achieve a high pure inertial position accuracy of 0.09 NM/hour by this method.

e. Ultra Short Base Line (USBL) System

Acoustic navigation systems for underwater vehicles are produced by many companies but USBL systems with full depth capability are very rare. Watanabe *et. al.* (Watanabe 2006) have developed a small USBL system for full depth use. The system consists of two major parts: a USBL transceiver installed on the station and a transponder fixed on the probe. Table 1 shows the specifications of the USBL system. The accuracy of the position is relatively low because the probe position is directly obtained using the station TV camera in their plan. In this system, the M-sequence signal is used as the modulation signal. An original processing unit has been developed using a DSP (Black Fin produced by Analog devices) and an FPGA (Cyclone produced by Altera). The system was tested in the Marianas Trench in 2008.

2.2 Communications devices and methods needed for each vehicle

Optical communication systems allow operators access to high speed data delivery and allows real-time control of a vehicle. The systems are widely used for communications

Items	Specifications
Beam width	120 deg
Accuracy	<5% within 200 m range
Range	2,000 m
Depth rating	11,000 m
Frequency	20 kHz
Modulation	BPSK
Data	M-sequence signal
Sensors	Sound velocity meter
Transducer	4 array
TX sound pressure	180 dB re uPa at 1m
RX sensitivity	-210 dB re 1V/uPa at 1m

Table 1. Specifications of the USBL

solutions with ROVs, UROVs and HROVs. In recent years, data traffic on networks has drastically increased with the evolution of broadband networks. In order to meet the demand, developers are trying to develop a 40 Gbps optical communication system using a dense wavelength division multiplexing technique for land and submergible cable applications.

For wireless remote control and status monitoring of AUVs, an acoustic communication system or an acoustic modem is used. This is also effective for monitoring an UROV or an HROV. For close-range communication, electromagnetic communication would be useful because radio communication performance would be less affected by multi-pass interference. Optical communication systems having a capacity of 622 Mbps and 2.488 Gbps are generally used for underwater vehicles. Prizm Advanced Communication Electronics Inc. provides a communication board with an HD-SDI interface. Canare in Japan manufactures fiber-optic products including an 8-channel coarse wavelength division multiplexing HD-SDI transceiver module. Neither of these manufacturers produces an all-in-one optical transceiver, which would consist of video interfaces, serial data interfaces, and parallel interfaces on one printed circuit board. Yoshida *et. al.* (Yoshida 2007b) have developed two types optical communication boards: one is an optical-electrical communication system for the *ABISMO* system and the other is a high speed device for an UROV vehicle, with the prototype being installed in the *PICASSO* system.

a. An Optical-electrical Communication System

The *ABISMO* system consists of a launcher and a vehicle. The support ship and launcher are mutually connected by optical fiber cable for data transmission. The launcher and the vehicle are mutually connected by a metallic cable. Three-point-communication (the ship - the launcher - the vehicle) is therefore needed in the *ABSIMO* system. The block diagram of the optical communication system model, JT3 for the ship-launcher communication and the radio frequency digital communication device, JT3-RC for the station-probe communication, are depicted in Figure 6. Its optical communication bit rate is the same as the SONET (STM-4) standard but the protocol is an original one. Every input signal is sampled, time shared, Manchester encoded, and then transmitted at a bit rate of 622 Mbps. The JT3-RC is a full duplex transceiver with 8 RS-232C channels. In the JT3-RC circuit board, its synchronization is achieved by a sequential synchronization using Manchester encoding with a 16 bit preamble. The time-division multiplex data rate is 12.96 Mbps. Maximum transmission range is designed to be 200 meters by using 2.5-2 V standard coaxial cable. A pre-emphasis

circuit reduces deformation of the transmission wave caused by loss through the cable. This system was practically tested in the Marianas Trench in June 2008 at a depth of 10300 m.

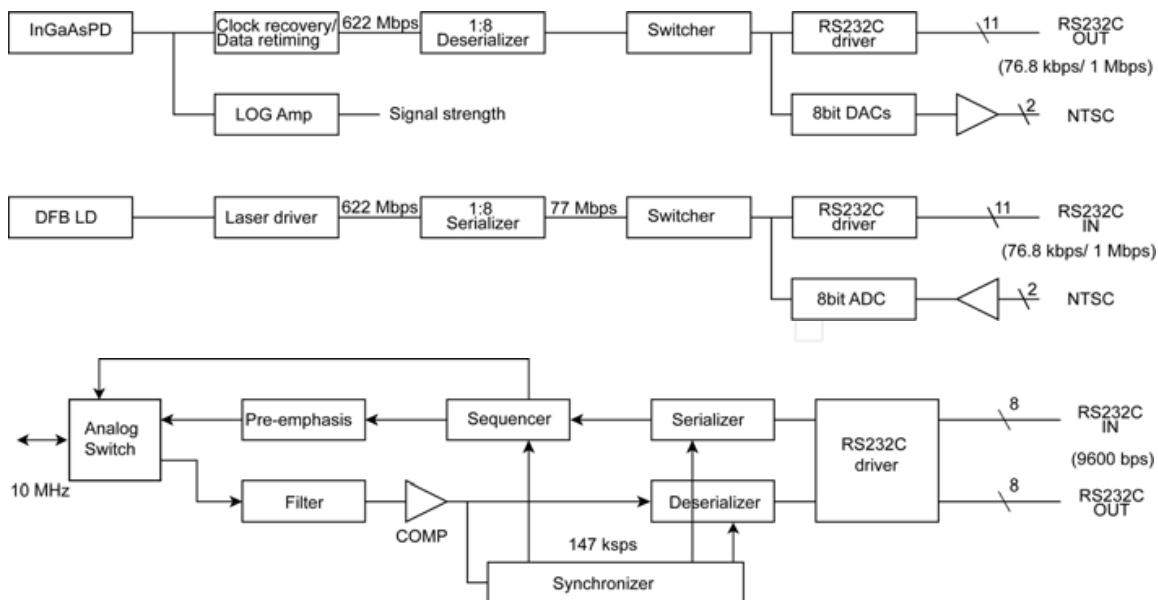

Fig. 6. The block diagram of the optical communication part of the JT3 (upper) and the blockdiagram of the JT3-RC. The synchronizer in JT3-RC regenerates the sampling clock.

b. A Low Cost 2.5 Gbps Optical Communication System with HD-SDI Interface

The system consists of a pair of transceiver units for the vehicle and the ship side. The transceiver unit consists of two printed circuit boards: a protocol converter board and a power supply board (each board size is 120 x 80 mm). Major devices for the converter are a 2488 Mbps optical transceiver module produced by Sumitomo Electric Industries, Ltd. and a TLK3101 transceiver chip by Texas Instruments Incorporated which is composed of 2.5 Gbps to 3.125 Gbps Serializer / Deserializer. The transceiver has the interfaces: one HD-SDI data interface for an HDTV camera, three NTSC interfaces, four RS-232C interfaces, two RS-485 interfaces, and 8-channel parallel I/O interfaces.

c. Acoustic Modem Using Time-Reversal Waves in Shallow Water

An advanced acoustic communication method utilizing time-reversal waves has been developed (Kuperman 1998, Shimura 2004). In most acoustic communications the ship-vehicle configuration is vertical because there are many multi-path signals in the horizontal configuration. It would be better to use a time-reversal technique for communication under multi-path fading in the shallow water zone. Shimura did a simulation for communication between a ship and a vehicle in the shallow water zone using high frequencies (Shimura 2006). He reported that the method of time-reversal process with an adaptive filter provides good communication results. When the vehicle, however; moves, the advantage of the method is depressed. We will try to modify the method and choose the best parameters, aiming at better ship-vehicle communication up to 500 m in distance.

d. Communication by Electromagnetic Field.

In seawater the attenuation coefficient, α in the HF band and below is obtained by equation 3 which is derived from Maxwell equations.

$$\alpha = 8.686 \times \sqrt{\pi \mu_0 \sigma_0} \sqrt{f} \text{ (dB/m)}, \quad (3)$$

where μ_0 is the permeability, σ_0 is the conductivity of the seawater, and f is frequency in Hertz. Substitution of $\mu_0 = 4\pi \times 10^{-7}$ and $\sigma = 4 \text{ S/m}$ into equation 3, one obtains,

$$\alpha = 3.45 \times 10^{-2} \sqrt{f} \text{ (dB/m)}. \quad (4)$$

The equation means that an RF wave in seawater is rapidly damped, for example 128 dB/m at 10 MHz. A number of tries at RF communication in seawater have been made. Siegel attempted propagation measurements in seawater at 100 kHz and 14 MHz (Siegel & King 1973) by preparing a special underwater antenna. They concluded that the experimental data are in good agreement with theoretically obtained data from asymptotic formulas. A new approach to electromagnetic wave propagation through seawater has been proposed (Al-Shamma'a 2004). In their theory, there are conduction currents in the near field and displacement currents in the far field. This causes rapid signal attenuation in the vicinity of the antenna but in the far field the attenuation is comparable with the dielectric loss. JAMSTEC has also carried out propagation measurements in seawater from a quay. The propagation characteristics in the ELF roughly agreed with the theoretical characteristics. The curve according to the HF measurement data as shown in figure 7 is similar to the one that Al-Shamma'a obtained. This means that someone should make a careful investigation at HF.

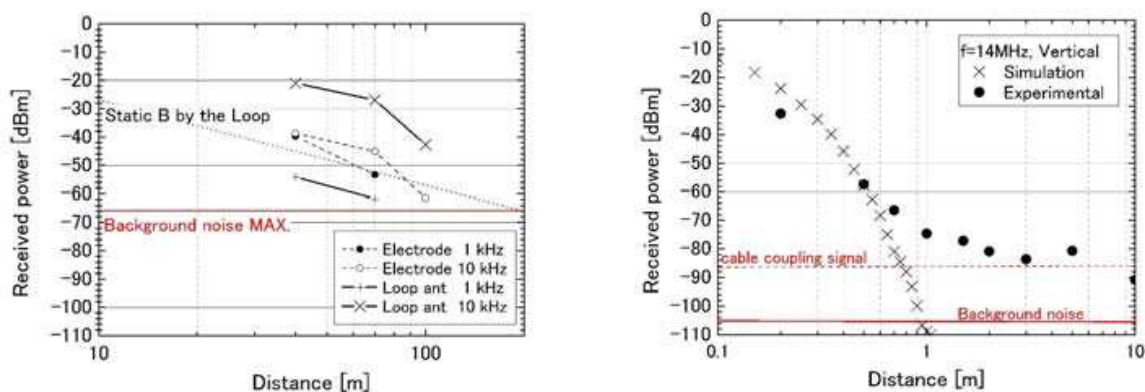

Fig. 7. Propagation characteristics of electromagnetic waves in seawater in the ELF band (left) and the HF band (right).

JAMSTEC has been developing a new communication tool that uses electromagnetic waves. This method is used for mutual communication between vehicles at up to 50 m distance. A prototype transmitter, a receiver, and antennas were made. An NTSC camera for underwater use was connected to the transmitter. The transmitter encodes and modulates the image data and then supplies power of 17 Watts to a multi-turn coil antenna. A high sensitivity search coil antenna receives the modulated data. The receiver demodulates, decodes, and outputs the image in QVGA format. In the tank test, QVGA images were transmitted to the receiver set 30 m away from the transmitter.

e. Satellite Communication system

Most satellite communications from the ocean use an earth orbiter satellite, for example Argos satellites and Iridium satellites, rather than a geostationary satellite because the latter needs a large sized antenna such as a parabolic antenna. However, a geostationary satellite can provide full real-time communication and a large coverage area. The Eighth

Engineering Test Satellite, ETS-VIII has as its main purpose, dealing with the increasing demand for digital communications, such as mobile phones and other mobile devices. The satellite (weight of 3 tons and diameter of 40 m) has two Large Deployable Antenna Reflectors (LDARs). Table 2 lists specifications of the ETS-VIII.



Fig. 8. Picture of ELF wave transceiver tested in tap water and a received image.

Figure 9 shows the concept of this project. Devices or facilities on the ocean are able to communicate with land stations via a satellite with a large capacity wireless network. This enables us to remotely control these devices or facilities, resulting in effective research in marine-earth science. By using the ETS-VIII, remote control of an underwater vehicle from a land station at JAMSTEC as shown in Figure 9 will be possible. For this purpose development of a satellite communication system with help from the Japan Aerospace Exploration Agency and National Institute of Information and Communications Technology was started since 2003.

Items	Spec.	Unit	Remarks
Downlink freq	2500.5-2503.0	MHz	
Up link freq	2655.5-2658.0	MHz	
Satellite EIRP	61.8-63.8	dBW	
Satellite G/T	12-14	dB/K	
Satellite Antenna Gain	41	dBi	
Communication rate	64 - 384	Kbps	internal ant

Table 2. The specifications of ETS-8.

A custom antenna is needed for underwater vehicles because there is no commercial pressure-tight or water-resistant small antenna. A left-handed circularly polarized; double resonance antenna is matched to the ETS-VIII. Antenna minimum gain is 6.3 dBi. A four-element patch antenna, with a gain of about 14 dBi, and a single element patch antenna with phase difference feeding lines were made. The gain of the single element planar antenna is only 7 dBi. By decreasing the communication rate by 64 kbps, which gains 7 dB on power per bit compared with 384 kbps, antenna margin is kept.

The ocean-based system should be equipped with a satellite tracking system to lock on to the satellite, because of the vehicle oscillation. The tracker must also be water-resistant. For these reasons, a tracking system has developed using data on network design and the oscillating characteristics of the *Urashima* vehicle. Oscillation of the vehicle was measured with the high accuracy inertial navigation system installed in *Urashima* in a sea trial. An oscillation angle of 7 degrees and period of 0.15 Hz were estimated. We set the design target to pitching and rolling angles of less than 20 degrees and maximum frequency of 0.5 Hz. The tracking system consists of an attitude sensor and an attitude controller. To obtain the direction of the satellite, an inertial navigation system and a GPS are used as attitude sensors. The attitude controller has a three axis stepping motor driver. The system is currently undergoing tests with the first sea trial in November 2008.

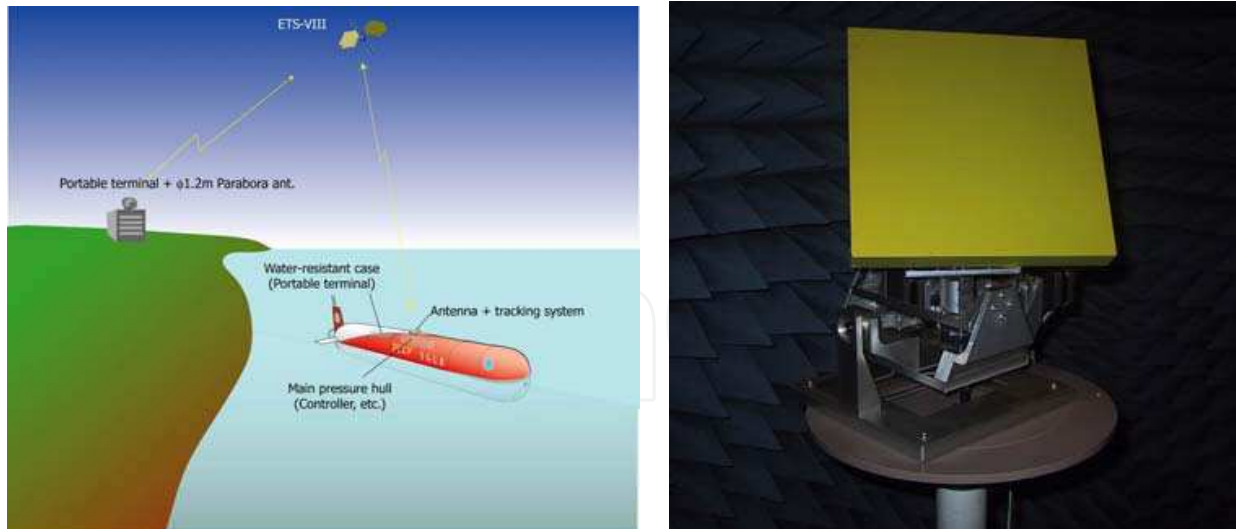

Fig. 9. (left) An image of satellite communications with an underwater vehicle. (right) Photograph of the attitude controller with the 4-element planar antenna.

2.3 Modern power sources

Power sources are extremely important in underwater vehicle development, in particular for AUVs, UROVs and HROVs. Power source capacity limits the cruising range and mission style of underwater vehicles. Two main evaluation factors for power sources are the specific energy, energy per unit mass: Wh/kg, and the energy density, energy per unit volume: Wh/L. In vehicle design, not only the energy of the power source is considered, but also the maximum output power. In this section, modern power sources for intelligent underwater vehicles, secondary batteries and fuel cells in particular are described because these are rechargeable and are able to be run in a closed system in the underwater environment.

a. Batteries

A number of kinds of secondary battery, lead-acid, silver-zinc, nickel-MH, lithium-ion and lithium-polymer batteries are utilized in AUV design. Lithium-ion and lithium-polymer batteries have the advantages of easy handling, higher energy density and longer cycle life as shown in Table 1. Davies and Moore (Davies 2007) have proposed the ratio of specific energy and energy density, D as an index for helping power source design.

$$D \text{ (kg/L)} = \text{energy density} / \text{specific energy} \quad (5)$$

If D is smaller than the density of seawater, approximately 1.03 kg/L, a battery system has positive buoyancy. Calculating the D of various batteries from table 1, it can be seen that lithium type batteries have a smaller density than other types. We thus focus on lithium-ion batteries and lithium-polymer batteries because they have good prospects for future use and development (Armand 2008). Both batteries use lithium metallic oxide in the cathode and carbon material in the anode. Lithium-ion batteries use lithium ions in an electrolyte inside the battery and these transfer between the cathode and the anode during charge or discharge. In contrast lithium-polymer batteries use a solid polymer composite. The advantages of Li-polymer over the lithium-ion design include lower cost of manufacturing and being more robust to physical damage.

Battery Type	Specific energy, Wh/kg	Energy density, Wh/L	Cycle life
Lead-acid	20-30	60-80	700
Silver-zinc	100-120	180-200	100
Nickel-MH	50-70	100-150	1500
Lithium-ion	90-150	150-200	600-1000
Lithium-polymer	130-190	170-240	300-3000

Table 3. Performance of batteries (ref. Abu Sharkh 2003)

Lithium type secondary batteries have been used in a number of AUVs including Autosub6000 (McPhail 2007), ABE (Bradley 2000), Nereus (Bowen 2004), MMT3000 (Gornak 2006), and *Urashima* (Aoki 2001). REMUS, which is a mass-produced compact AUV developed at WHOI and is now commercially available only through Hydroid, Inc., also uses lithium ion batteries. Autosub6000, 5.5 m long and 2000 kg in weight, runs over 1000 km at 1 m/s and is powered by 12 pressure balanced Lithium-polymer battery packs including Kokam cells. Each pack stores energy of 18 MJ within 405 battery cells. The *Urashima* vehicle, designed by JAMSTEC, is powered by two pressure balanced lithium-ion battery packs: a main battery pack of 15.6kWh of energy and a 3.6 kW sub battery pack. It has travelled over 120 km and the energy density of its batteries is about 180 Wh/L. JAMSTEC has investigated lithium-ion battery performance by changing the cathode material and battery shape. They have now obtained a sheet type lithium-ion battery with an energy density of over 210 Wh/L. A pressure resistance test using an oil-filled pressure balance case was done up to 11000 m in depth.

Utilization of lithium-based batteries will continue for a considerable period of time in the future because most small AUV designers will choose higher energy density batteries and a vehicle mounting a generator requires a battery for start-up. The nanotechnology revolution will help increase the performance of lithium ion batteries in terms of capacity, power, cost, and materials sustainability (Armand 2008) in the near future. Lithium-oxygen batteries, which can have a capacity of 1200 mAh/g according to the reaction $2\text{Li} + \text{O}_2 \rightarrow \text{Li}_2\text{O}_2$, have greater potential compared with lithium-ion batteries of about 150 mAh/g, theoretically. There are now prominent failures in this type of battery but Armand expects that much more work may break through the issues after 2050. If this battery becomes of practical use, the cruising range of every AUV will see an eightfold increase from that of present AUVs.

b. Fuel Cells and Semi-Fuel Cells

A semi fuel cell is a generator but its usability is rather like a battery because it requires a reactant, hydrogen peroxide, besides an exchange of the anode, due to corrosion of the aluminium cathode in the electrical generation process, and the electrolyte. Aluminium/hydrogen peroxide energy semi-fuel cells can theoretically generate an energy density of 3418Wh/kg and practically one of about 400 Wh/kg. This corresponds to 3 times that of a lithium-ion system. This type of semi-fuel cell contains only liquid and solid materials, independently running under the ambient pressure. A vehicle designer is thus able to design a pressure balanced battery system with a semi-fuel cell. A semi-fuel cell would be suitable for mid size underwater vehicles because the size of a pressure-hull-less semi- fuel cell is not so large (Adams 2002). The Hugin 3000 autonomous underwater vehicle, 5 m long and 1400 kg in weight, uses a semi fuel cell as the main power source (Hasvold 2002). This semi-fuel cell generates energy of 45 kWh for 50 hours.

Many types of fuel cell system have been developed around the world. Proton exchange membrane fuel cells (PEMFC) are the most suitable for underwater applications such as for autonomous underwater vehicles. Its operation temperature are around 70 degrees Celsius and its reactive product is only pure water. Underwater, a typical PEMFC system for land applications, such as found in automobiles, cannot be used because intake air does not exist underwater and the water reaction product is not easily drained into the high pressure external environment. The underwater vehicle *Urashima* is equipped with a closed-cycle PEFC system that consists of a fuel cell generator, high pressure oxygen tank, and a metal hydride tank. Its generating system must be perfectly closed so that there is no emissions underwater. The energy density of the fuel cell generator itself is high, although for the whole fuel cell system has a lower value due to weight gain from hydrogen, oxygen, and reactant water tanks, auxiliary components, and control electronics. Decreasing the size and weight of these devices is needed for underwater applications of fuel cell technology.

JAMSTEC has developed underwater vehicles for surveys in the vast underwater environment. The vehicles are utilized for sea floor observations, ocean environmental research, energy source exploration, and research on marine organisms and micro-organisms. One of the important underwater vehicles is an AUV with a large capacity energy source, a highly accurate positioning system, and a smart control system for autonomous cruising. In 2005, JAMSTEC made a world record of cruising distance of 317 km by the autonomous underwater vehicle *Urashima*, powered by a closed-cycle PEFC system. They aim to develop an underwater platform that can survey across entire oceans for scientific research into global climate change, ocean-trench earthquakes, marine microorganisms and multicellular organisms. In 2007, they started research and development on a second generation long-range cruising AUV (LCAUV) to cruise over 3000 km. The development of an improved power source for the vehicle is important to realize this goal. A fuel cell system has to be the best choice for a power source aimed at long-range cruising with a limited payload.

The PEFC system for the LCAUV must satisfy the following requirements; 1) high efficiency (over 60 %), 2) fuel of pure hydrogen and oxygen and downsizing of the storage system, 3) leakless stacks, 4) perfectly closed system, 5) over 600 hours continuous running time (need high reliability and durability), and 6) small system. Table 1 shows the power system specifications required of successive LCAUVs.

Term	Platform	Endurance	Range	Power	capacity
1998 - present	Urashima	60h	300 km	4 kW (Max)	180 kWh
2007 - 2015	2nd LCAUV	600h	3,000 km	10 kW (Max)	5000 kWh
2016 or later	3rd LCAUV	?	10,000 km	?	?

Table 4. Power system specifications

Urashima, the first prototype of a fuel cell-driven underwater vehicle built by Mitsubishi Heavy Industry Ltd., has the following specifications: length; 10 m, weight; 10 tons, maximum depth rating; 3500 m, maximum cruising speed; 3.2 knots, and endurance; 60 hours. Fuel cells for underwater vehicles should run on pure-hydrogen and pure-oxygen since no air exists underwater. The water byproduct produced in the fuel cell should be stored in the vehicle body to keep its buoyancy constant. If the reactant water is pumped into the external environment, the vehicle consumes much more energy and the vehicle loses weight and will start to float. We have thus developed a completely closed fuel cell

system, which confines energy resources and reactant water to the system, namely the closed-cycle PEFC system as shown in Figure 10. This FC system consists of two stacks, recirculation blowers, humidifiers, a heat exchanger and a reactant water storage tank, generating power of 4 kW. All devices are installed into a titanium pressure vessel. The coolant water from the FC stack is reused to humidify the hydrogen gas. A metal hydride (MH) vessel and a high-pressure oxygen tank are included. The heat generated in the FC stack is applied to heating the MH to extract hydrogen from the MH and the excess heat is radiated into seawater. Figure 11 shows a typical I-V plot of the PEFC system obtained in the 317 km sea trial. The maximum FC system efficiency was about 54 % at typical cruising speed.

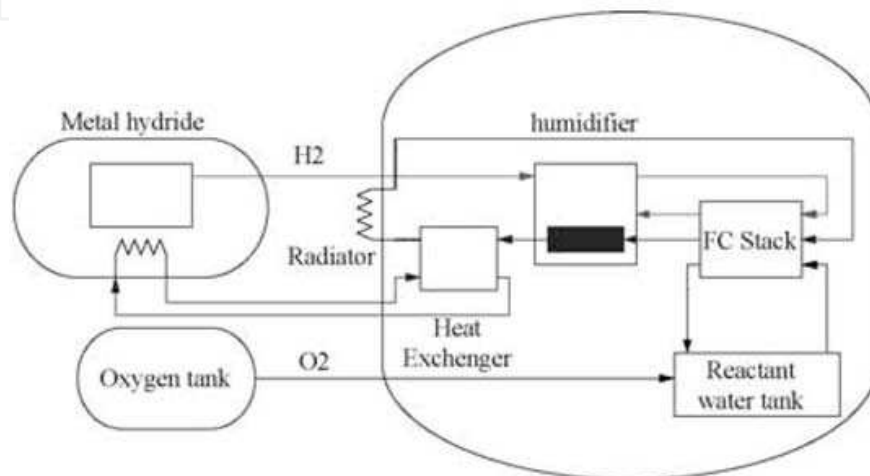

Fig. 10. System configuration of the closed-cycle PEFC for *Urashima*.

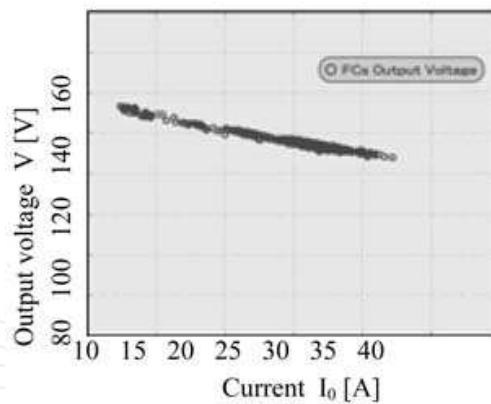

Fig. 11. I-V plotting of the closed-cycle PEFC during a 317 km.

The target cruising range of the 2nd LCAUV has increased tenfold from that of the *Urashima*. JAMSTEC has set target specifications for the fuel cell system, with system efficiency of over 60 % and downsizing of the pressure vessel and tanks as shown in Table 2. They made and tested a single cell which consists of a solid polymer electrolyte membrane, carbon black, platinum-alloy, carbon paper, and metallic separators. The test was done under the following conditions: cell temperature of 60 degrees Celsius, process pressure of 300 kPaA, and gas utility factor of 50 %. Figure 12 shows an I-V plot of the new cell compared with the *Urashima* system. In the figure the circle and the square show that of *Urashima* and that of the new cell, respectively. They have a single cell efficiency of 60 % at a higher heating value

in the target current point. Now JAMSTEC has designed a blower- and humidifier-less system using the new cells.

Platform	Efficiency	Volume ratio
Urashima	54 %	1
2nd LCAUV	60 %	1/2 or less

Table 5. Required PEFC specifications for underwater vehicle

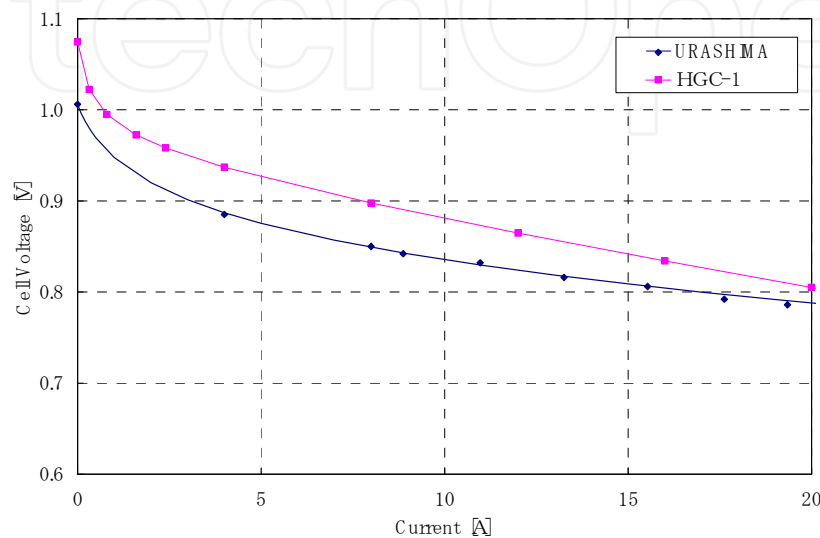

Fig. 12. I-V curve of new cell

3. Data processing

3.1 Control hardware: internal communication bus and distributed CPU system

In control hardware robustness, reliability, high speed, synchronization are important. A distributed CPU system reduces concentration of processing load on a single CPU and allows system redundancy. A distributed CPU system can be composed of printed circuit boards with an embedded CPU chip and an internal bus. In the distributed real-time system, it is important which internal bus is the best for the system considered. Some researchers (Weidong 2006, Blandin 1998, Yoshida 2004) proposed the the Controller Area Network (CAN) bus which was originally developed in the 1980's by R.BOSCH GmbH as an internal bus for AUVs. The CAN bus is based on the broadcast communication mechanism. Every message has a message identifier, which is unique within the whole network since it defines content and the priority of the message. The CAN bus also has the mechanism of bit and frame synchronization. The maximum data transmission rate of CAN is 10 MHz.

3.2 Image sensing and recognition

a. Midwater Organism Tracker

PICASSO will semi-automatically track animals in midwater. In order to detect and track an animal the vehicle has to incorporate animal image recognition and then automatically move so as not to lose the animal that has been recognized. JAMSTEC has developed a prototype system for an animal tracker using the *MROV* vehicle. To simplify the prototype system, only the pan-tilt system of the camera rather than the entire vehicle itself was

controlled by the tracking program. Color deference in HLS (Hue, Saturation, Luminance) color space was basically used for detection. Identification of a target is initially done by clicking on the target on the display. RGB values in the 9×9 pixels around the pixel clicked are converted to the HLS color space. A center of gravity for pixels with the near-HLS value obtained is then calculated. When the distance between the center of gravity and the center of the image obtained by the camera exceeds a preset limit of the pan-tilt, the program controls the camera to center the animal in the middle of the observation space. The program also has a displacement prediction function to predict movements of animals. A detection and tracking test was carried out in the large fish tank (6.5 m in depth, 144 m² area of base) at the Enoshima Aquarium. A scene taken during the test is shown in Figure 13. The prototype system was able to detect and track a small fish (red circle in the figure) for 30 seconds in this test. However, in most cases the duration of capturing the target was only a few seconds because there were many fish in the tank and the background-target contrast was low compared to in the midwater zone of the ocean. For more accurate detection, they will collaborate on an image recognition method with MBARI (Walther 2004). This method simulates human vision functions and has a high target recognition probability. JAMSTEC will also investigate a program to track animals by linking this output with thruster control.



Fig. 13. A tracking test using the MROV in the Enoshima Aquarium. The cross shows the tracking point.

4. Present intelligent underwater vehicles

In this section, vehicles, equipped with state-of-the-art devices, that were developed at the institute for which the author works are the mainfocus.

4.1 Plankton survey vehicles

Research on planktonic organisms is important because they are the link between greenhouse gases being absorbed by the ocean and the final burial of these gases as solid organic carbon in deep sea sediments. Planktonic organisms also occur at very high point biodiversities and insights into how so many species can co-exist in a seemingly homogeneous environment should help shed light on aspects of biodiversity that need to be grasped for protection of biodiversity hotspots and to understand evolution.

Several trials with ROVs and manned submersibles (Wiebe & Benfield, 2003) have been carried out to investigate the distributions of macro- and micro-plankton versus environmental parameters. In this way, one is only able to gain information of a point nature and it is not possible to determine large-scale distributional patterns with limited ship-time. Both winch-controlled towed systems (MOCNESS net, BIONESS net, BIOMAPER-II system) have been equipped with a combination of imaging, acoustic and environmental parameter sensors. However, the maximum operation depth for the BIOMAPER-II and SeaSoar were only 300 m and none of these systems had imaging systems of high enough resolution to identify and quantify plankton at the species level (Wiebe & Benfield, 2003).

Since 2005, JAMSTEC has been developing a multiple-platform autonomous survey system able to quantitatively characterize the midwater environment, including fragile components such as large particulates and gelatinous plankton. This system could be deployable from small to medium sized boats and ships.

Since 2006, we have developed the first small vehicle named *PICASSO-1* Plankton Investigatory Collaborating Autonomous Survey System Operon-1. Fig. 14 shows a snap shot of *PICASSO-1* during a sea trial. *PICASSO-1* is small and light (2.4 m long, 200 kg in weight) and the color of the hull is mostly red because deep sea organisms cannot see light or reflections in the red spectrum as a rule. The vehicle system consists of an on-board topside module and a vehicle, and these are connected via a thin optical fiber cable. One remotely controls the vehicle from the topside module. *PICASSO-1* is composed of the following major parts: an FRP fairing cover, a body frame, buoyancy materials, controllers, communication systems, three 100 W thrusters, one tilt actuator, lights, devices for navigation and observation, oil-filled lithium ion battery, and an optical fiber spooler. The vehicle has one vertical tail fin and two fins for stability. Table 6 shows the *PICASSO-1* specifications.

Item	Specification	Remarks
Dimension	2.1 m x 0.8 m x 0.8 m	without VPR
Weight	200 kg	in air
Depth rating	1,000 m	
Cruising speed	2 kt	
Endurance	6 hours	
Operation mode	UROV	
Propulsion	2 horizontal 100 Watt thrusters with tilt system, 1 vertical 100 Watt thruster	
Communications instrumentation	2 G bps optical communication device , Radio LAN, ARGOS transmitter, acoustic and magnetic transceiver*.	
Navigation instrumentation	MEMS gyro, Doppler velocity log, depth meter, SSBL, compass	
Experiment payload	CTD, TDO, Fluorometer-Turbidity sensor, 4 x NTSC cameras, 3 x 35 Watt HID lamps, Visual Plankton Recorder*, High definition TV camera*, Digital still camera*, 400 watt HID lamp*.	* pick only one device

Table 6. Specifications of *PICASSO-1*

One of the purposes for development of the system is to track plankton. A typical swimming velocity for plankton is slow, a few hundred meters per hour (Matsumoto 1991), and its direction of swimming is random. *PICASSO-1*, therefore; has two lateral thrusters with a 180 degree tilter and a vertical thruster for highly maneuverable cruising and its maximum cruising speed is set to 2 knots. For smaller to larger animal observations, *PICASSO-1* is able to select as its main imaging tool from among three choices: an HDTV camera, a 12 bit high resolution camera, and an underwater “microscope” called the color Visual Plankton Recorder (VPR).

b. The sea trial of *PICASSO-1* in February-March 2007

A sea trial was carried out in 24 February – 4 March in Sagami Bay and Suruga Bay using the support vessel, *Natsushima*. Seven dives were made. In two dives, the VPR was installed on *PICASSO-1* (Figure 14). The vehicle dived to a maximum depth of 601 meters. All function tests were performed well. The images obtained by the HDTV camera were of extremely high quality and several animals were observed. Meso zoo plankton were observed by the VPR (Figure 15). This first sea trial of *PICASSO-1* was successfully finished. Up to the present date *PICASSO-1* has made 25 dives, including dives using a small support ship (Yoshida 2008).



Fig. 14. *PICASSO-1* with the Visual Plankton Recorder being recovered.



Fig. 15. An undescribed species of Bathyctenid comb jelly and a Gnathophausid mysid shrimp obtained by the Visual Plankton Recorder installed in *PICASSO-1*.

4.2 Automatic sediment sampling ROV at full ocean depth

The *ABISMO* system and its 11,000m-cable store winch are mounted on the dedicated ship *Kairei*. The *ABISMO* system consists of an on-board control module which is installed in the ship, a sampling station, a sediment probe, and two samplers. Fig. 16 shows a recovery scene of the station housing the probe. The on-board control module is connected with the station via the primary cable. The secondary cable, which has been newly developed, connects the station and the probe. The sampling station houses the probe and one of the samplers in the bottom cage. The station is mounted with a docking-undocking system and a secondary cable drum for the probe, sampler release gear and a rope-hoisting winch for the sampler. The station furthermore serves as a repeater between the on-board equipment and the probe. The probe cruises below the station freely within the reach of the 160 m cable to survey the sea-bottom surface with a TV camera. The probe is able to take a small sediment sample with a mini manipulator. Two types of sediment samplers - a gravity core sampler and a grab bottom sampler have been prepared. Scientists can choose either sampler in accordance with the intended use. The system specifications are shown in Table 7.



Fig. 16. The full depth ROV, *ABISMO*

Item	Launcher	Vehicle
Rated Depth	11,000 m	11,000 m
Dimensions	3.28 x 2.09 x 1.76(2.78*) m	1.22 x 1.30x 1.215m
Weight in air	3,070 kg	327 kg
Weight in water	2,300 kg	97 kg
Depth rating	11000 m	11000 m

* overall height including the vehicle

Table 7. Specifications of *ABISMO*

a. The first sea trial of the *ABISMO* system in January 2007

The first dive was made at Yokosuka 4th district in Tokyo bay to check system function on January 5. The test results were good and the ship then headed to Sagami Bay. During the second dive an assessment was made as to whether the station thruster could constrain its self rotational motion caused by the primary cable twisting or not. The thrusters behaved well during the 200 meter dive. On January 8 we tried sampling with the gravity core sampler at a location where the bottom sediment was softish, at a depth of 480 m. The station was controlled keeping its heading, coming as close as about 80 meters off the bottom. Keeping its altitude, the sampler was dropped. The sampler was recovered after about ten minutes. A sediment sample about 200 mm long then was obtained.

b. The successful sea trial in the Mariana Trench in June 2008

The fourth sea trial including dives in the Mariana trench had been made from 26th May to 8th June 2008. Before going to the Mariana trench, one dive at Sagami-Bay and also one dive in the Izu-Ogasawara trench were conducted to confirm the additional functions and also the functions that had not been tested in the previous sea trials. In the Mariana Trench *ABISMO* made three dives within three days to depths below 10,000m and marking a 10,257m dive. This depth was limited by the length of the primary cable. The 2-m long gravity core sampler was dropped down in free fall and sediment cores of 1.6 m length were obtained (Figure 17). *ABISMO* also succeeded in obtaining 12 bottles of water samples from the Mariana trench in each dive.



Fig. 17. Mud sample obtained from the sea floor in the Mariana trench (2m-core sampler)

4.2 Cutting edge autonomous underwater vehicles

The prototype AUV *Urashima* is an LCAUV with a range over 300 km, as shown in Figure 18. Its specifications are listed in Table 1. The vehicle consists of titanium frames covered with FRP (Fiberglass Reinforced Plastics) faring covers, pressure vessels made of titanium alloy for protecting control systems and other electrical devices, and buoyancy materials used for additional buoyancy. The vehicle has a cylindrical shape for reducing hydrodynamic drag. The vehicle is equipped with six actuators: a main thruster (D.C. brushless motor, 1.5 kW) for cruising, two vertical thrusters, one horizontal thruster at the stern, a vertical rudder, and a horizontal rudder. The vehicle also has a pitch control system like a level adjuster and buoyancy control system which consists of an oil tank contained in a pressure vessel (VBT: Variable Ballast Tank) and an oil bladder. The system is able to change buoyancy from 0kg to 60kg according to water depth. The vehicle is powered by a fuel cell-battery hybrid power system as mentioned.



Fig. 18. Deep & Long range Cruising AUV, *Urashima*.

Item	Specification
Dimension	10.6 m x 2.55 m x 2.4 m
Weight in air	10,000 kg / 75,000 kg without the FC system
Depth rating	3,500 m
Cruising speed	3 kt
Endurance	60 hours
Navigation instrumentation	Inertial Navigation System, Doppler Velocity Log, Acoustic Homing Sonar, Obstacle Avoidance Sonar
Experiment payload	Side Scan Sonar, Multi Beam Echo Sounder, Sub Bottom Profiler, TV camera, CTDO, Digital Camera

Table 8. Specifications of the *Urashima* vehicle

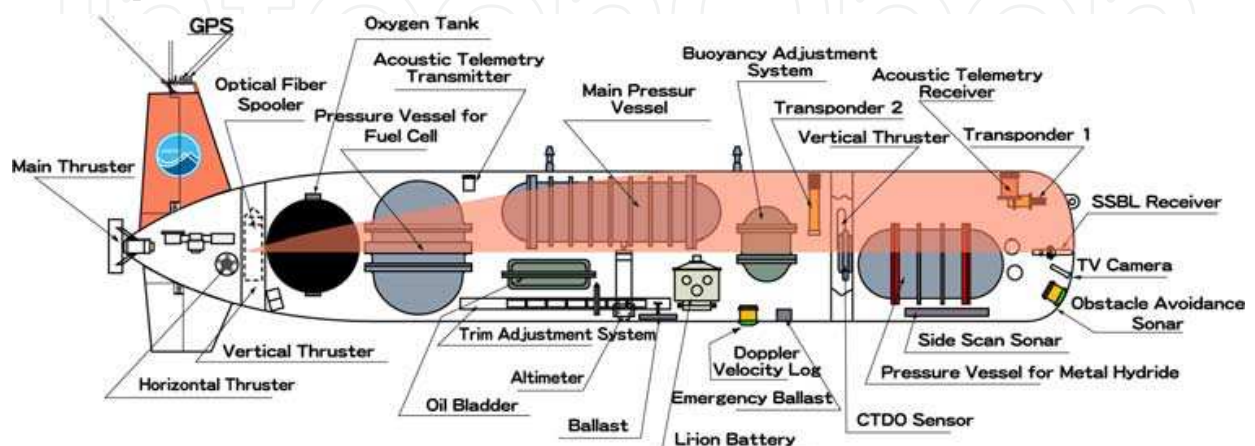

Fig. 19. General arrangement of *Urashima* with the Fuel Cell

The *Urashima*, the biggest AUV in the world, has a large payload capacity of about 500kg. Regular equipment for observations are a TV camera, digital still camera, a CTDO, a side scan sonar, a multi-beam echo sounder and a sub-bottom profiler. The side scan sonar, which has maximum range of 500 m, is a dual frequency type that projects acoustic waves at 120 and 410 kHz at central frequency. The sub-bottom profiler is a chirp sonar that uses frequencies from 1 to 6 kHz, having maximum range of about 50 m. A receiver in an array with 6 channels can record phase data. The multi-beam echo sounder observes bathymetry. The sounder uses 400 kHz burst acoustic waves, ranging about 300 m. The sounder works in a stand-alone mode. The control parameters of the sounder is set before a deployment.

The development project for the *Urashima* is started in 1998. The vehicle powered by a lithium-ion battery system has had 10 sea trials and 40 dives by 2002. In these sea trials, the vehicle both achieved a dive to 3,518m in depth and cruised a distance of 132.5 km in autonomous navigation mode over 29 hours.

In 2003, the lithium-ion battery system was replaced with the fuel cell system and then tests of the fuel cell vehicle started. In February–March 2005, the vehicle achieved a cruising distance of 317km under autonomous navigation mode. The average cruising speed was 2.8 knots. The vehicle maintained a cruising depth of 800m. The performance of the fuel cell system was good throughout the test. Cruising time was 54 hours.

Figure 20 shows the track which measured by the INS at survey on a mud volcano obtained in July 2006 in the Kumano trough. The maximum depth of the survey area was almost 2,100m. Cruising speed was 2.5 knots. Although the vehicle sometimes had almost 30m differences from programmed altitude during rapid slope angle variations, the vehicle kept a stable altitude at approximately 80m above the seafloor while cruising in autonomous mode. The difference is 0.5m between the programmed course and the obtained course by the INS. The vehicle came to within 20m of the seafloor, and cruised at slopes up to 35 degrees. Cruising distance was 28km and cruising time was 8 hours. Figure 19 also shows an acoustic image of the mud volcano based on data obtained by the side scan sonar. The resolution is very high so that the details at the top of the mud volcano can be observed.

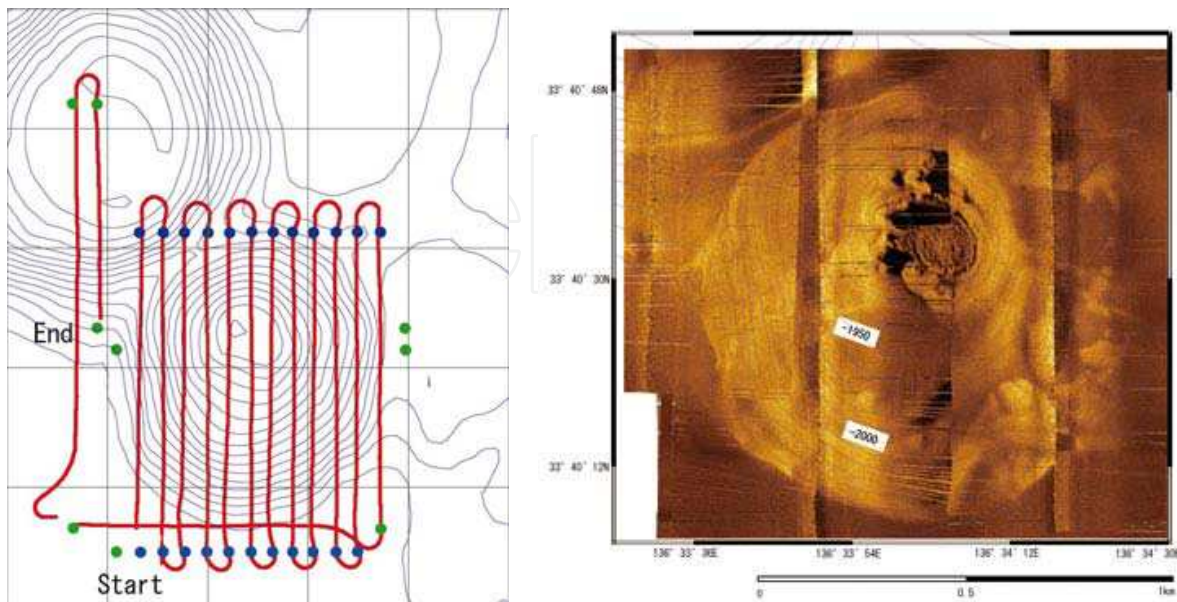

Fig. 20. Track of the vehicle during the survey of the mud volcano (left) and an acoustic image of a mud volcano obtained by the side scan sonar (right).

7. Conclusion

This chapter mainly presents information of hardware devices utilized in the development of new underwater vehicles. Basic devices including a stereoscopic HDTV camera system, communication devices and methods under development, modern power sources, and data processing methods are described. Power sources are extremely important in underwater vehicle design. The recent trends of Lithium-ion batteries, which are better for small to midsize vehicles design, and fuel cells for large vehicles are introduced. Three vehicles developed in JAMSTEC incorporated the mentioned devices and their sea trial results are shown. The development purpose of these vehicles is different but the techniques and the devices were shared in the development of each vehicle. As was mentioned in the introduction, state of the art underwater vehicles will enable a whole ocean research. The configuration of multiple deployment small AUVs and a large LCAUV may be an effective operation style in the future. The improvement of fundamental devices is essential to realize this goal. In order to improve the survey of climate change, assessment of earthquakes, and ocean resources, the accelerated development of intelligent underwater vehicles is also expected.

8. References

- Abu Sharkh, S. M.; Griffiths, G. & Webb, A. D. (2003), Power Sources for Unmanned Underwater Vehicles, In: *Technology and Applications of Autonomous Underwater Vehicles*, Griffiths, G. Ed., pp. 19-35, Taylor & Francis, ISBN 0-415-30154-8, London.
- Adams, M. & Halliop, W. (2002). Aluminium Energy Semi-Fuel Cell Systems For Underwater Applications: The State Of The Art And The Way Ahead, *Proceedings of OCEANS '02. MTS/IEEE*, Vol. 1, pp. 199- 202, ISBN: 0-7803-7534-3, Biloxi, Mississippi, 29-31 Oct. 2002.
- Al-Shamma'a A. I.; Shaw A. & Saman, S. (2004). Propagation of Electromagnetic waves at MHz Frequencies Through Seawater, *IEEE Trans. Antennas and Propagation*, 52, 11 pp. 2843-2849, 2004.
- Aoki, T.; Tsukioka, S.; Hattori, M.; Adachi, T.; Ietsugu, N.; Itoh, T.; Nakae, T. (1992), Development Of Expendable Optical Fiber Cable ROV "UROV", *OCEANS '92. 'Mastering the Oceans Through Technology'. Proceedings*. Volume 2, pp. 813 - 818, ISBN 0-7803-0838-7, Newport, Rhode Island, October 26-29,1992.
- Aoki, T.; Nakajoh, H.; Nakamura, T., Ochi, H.; Tamura K.; Murashima, T.; Tsukioka, S.; Hyakudome, T.; Ida, T.; Akazawa, K. & Hashimoto, K. (2001). Deep and Long Cruising AUV Hybrid-powered with Li-ion Battery and Fuel Cell, *Underwater Intervention Conference Proceedings*, 2001.
- Aoki, T.; Tsukioka, S.; Yoshida, H.; Hyakudome, T.; Ishibashi, S.; Sawa, T.; Ishikawa, A.; Tahara, J.; Yamamoto, I. & Ohkusu, M. (2008). Advanced Technologies for Cruising AUV Urashima, *Trans. of International Journal of Offshore and Polar Engineering*, Vol. 18, No. 2, pp. 81-90, 2008.
- Armand, M & Tarascon, J. M. (2008). Building better batteries, *nature*, vol. 451, no. 7, (2008) pp. 652-657.

- Blandin, J. & Leon, P. (1998). Network architectures for underwater systems: two applications of the CAN bus, *Proceedings of OCEANS '98 Conference*, Vol. 1, pp. 503 - 507, 28 Sept.-1 Oct. 1998.
- Bowen, A.; Yoerger, D. ; Whitcomb, L. L. & Fornari, J. (2004). Exploring the Deepest Depths : Preliminary Design of a Novel Light-Tehered Hybrid ROV for Global Science in Extreme Environments, *the Journal of the Marine Technology Society*, 38, 2,(2004) pp. 92-101.
- Bradley, A. M.; Duester, A.R.; Liberatore, S.P. & Yoerger, D.R., (2000). Extending the Endurance of an Operational Scientific AUV using Lithium-Ion Batteries, *Proceedings of Unmanned Underwater Vehicle Showcase (UUVS) 2000*, Southampton, United Kingdom, September 2000.
- Gornak, V.E.; Inzartsev, A.V.; Lvov, O.Yu.; Matvienko, Y.V. & Scherbatyuk, A.Ph. (2006). MMT 3000 - Small AUV of New Series of IMTP FEB RAS, *Proceedings of OCEANS 2006*, p.p. 1 - 6, ISBN: 1-4244-0115-1, Boston, MA, USA, Sept. 2006.
- Hasvold, O.; Johansen, K.H. & Vestgaard, K. (2002). The alkaline aluminium hydrogen peroxide semi-fuel cell for the HUGIN 3000 autonomous underwater vehicle, *Proceedings of the 2002 Workshop on Autonomous Underwater Vehicles*, pp. 89-94, ISBN 0-7803-7572-6, Feb. 19, 2002.
- Ishibashi, S.; Hyakudome, T.; Yoshida H. & Sawa, T. (2008). The Prototype To Control The Rotational Motion Applied To An Inertial Navigation System Equipped With An Autonomous Underwater Vehicle, *Proceedings of the Eighteenth (2008) International Offshore and Polar Engineering Conference*, p.p. 394-398, ISBN 1-880653-68-0, Vancouver, BC, Canada, July 6-11, 2008.
- Kuperman, W. A.; Hodgkis, W. S.; Song, H. C.; Akal, T.; Ferla, C. & Jackson, D. R. (1998). Phase conjugation in the ocean: Experimental demonstration of an acoustic time-reversal mirror, *J. Acoust. Soc. Am.*, 103, pp. 25-40, 1998.
- Larsen, M. B. (2002). High Performance Autonomous Underwater Navigation, *Hydro. International*, vol. 6, 2002.
- Matsumoto, G. I. (1991). Swimming movements of ctenophores, and the mechanics of propulsion by ctene rows, *Hydrobiologia* 216/217, pp. 319-325.
- Meacham, GB Kirby (1986). Autostereoscopic Displays - Past and Future, *Advances in display technology, Proc. of SPIE*, Vol. 624.
- McPhail, S. (2007). AUTOSUB6000 - a leap forward in capability: a long range and deep diving AUV for marine science, *National Oceanography Centre Southampton Informal Physics Seminar (POETS Corner)*, 29 March 2007.
- Murashima, T.; Nakajoh, H.; Yoshida, H.; Yamauchi, N. & Sezoko, H. (2004). 7000m class ROV KAIKO7000, *Proc. OCEANS '04 MTS/IEEE*, pp. 812 - 817, ISBN 0-7803-8669-8, Kobe, Japan, November. 9-12, 2004.
- Shimura, T. (2004). A study on the focusing property of time reversal waves in shallow water, *Acoust. Sci. & Tech.* 25, 5, pp. 364-372, 2004.
- Shimura, T; Yoshida, H. & Lindsay, D. (2006). Basic study on time-reversal communication in shallow water with high frequency, *Proc. of Techno-Ocean 2006 / 19th JASNAOE OES*. Paper No. 171., 2006.

- Siegel, M. & King, R. W. P. (1973). Electromagnetic Propagation Between Antennas Submerged in the Ocean, *IEEE Trans. Antennas and Propagation*, AP-21,4, pp. 507-513, 1973.
- Takai, K.; Inoue, A. & Horikoshi, K. (1999). *Thermaerobacter marianensis* gen. nov., sp. nov., an aerobic extremely thermophilic marine bacterium from the 11000 m deep Mariana Trench, *Int J Syst Bacteriol* 49 (2) pp. 619-628, 1999.
- Tsukioka, S. Aoki, T. Yamamoto, I. Yoshida, H. Hyakudome, T. Sawa, T. Ishibashi, S. Mizuno, M. Tahara, J. Ishikawa, A. (2005). The PEM Fuel Cell System for Autonomous Underwater Vehicles, *the Journal of the Marine Technology Society*, 39, 3, (2005) pp. 56-64.
- Walther, D.; Edgington, D.R. & Koch, C., (2004). Detection and tracking of objects in underwater video, *Proceedings of the 2004 IEEE Computer Society Conference on Computer Vision and Pattern Recognition*, Vol. 1, pp. I-544- I-549 Vol.1.
- Watanabe, M.; Tashiro, S. & Momma, H. (2004). Loss of the Full Ocean depth ROV Kaiko - Part 3: The Cause of Secondary Cable Fracture, *Proc. of 14th ISOPE-2004*, pp.199-202. Toulon, France, May 2004.
- Watanabe, Y; Mizuno, M.; Yoshida, H. & Ochi, H. (2006). The Acoustic Positioning for The Bottom Sampler, *Proc. of Techno-Ocean 2006 / 19th JASNAOE OES*. Paper No. 179., 2006.
- Weidong, L.; Li'e, G.; Yilin, D. & Jianning, X. (2006). Communication Scheduling for CAN bus Autonomous Underwater Vehicles, *Proceedings of the 2006 IEEE International Conference on Mechatronics and Automation*, pp. 379 - 383, 25-28, June 2006.
- Wiebe, P. H. & Benfield, M. C. (2003). From the Hensen net toward four-dimensional biological oceanography, *Progress in Oceanography* 56, pp. 7-136.
- Yoshida, H.; Lindsay, D. J.; Yamamoto, H.; Ishibashi, S.; Hyakudome, T.; Okuno, H. & Uemura, T. (2008). Development of the AUV/UROV "PICASSO". *The Proceedings of the 18th ISOPE conference*, Vol. II, p.p. 423-428, Vancouver, Canada, July 6-11, 2008.
- Yoshida, H., Lindsay, D.J., Yamamoto, H., Tsukioka, S., Shimura, T., and Ishibashi S. (2007a) Small hybrid vehicles for jellyfish surveys in midwater. *The Proceedings of the 17th ISOPE conference*, p.p. 127-131, Lisbon, Portugal, July 1-6, 2007.
- Yoshida, H.; Aoki, T.; Osawa, H.; Tsukioka, S.; Ishibashi, S.; Watanabe, Y.; Tahara, J.; Miyazaki, T.; Hyakudome, T.; Sawa, T.; Itoh, K.; Ishikawa, A. & Lindsay, D. (2007b). Newly-developed Devices for The Two Types of Underwater Vehicles, *Proceedings of OCEANS 2007 - Europe*, p.p. 1-6, ISBN: 978-1-4244-0635-7, Aberdeen, 18-21 June 2007.
- Yoshida, H.; Aoki, T.; Yamamoto, I.; Tsukioka, S.; Hyakudome, T.; Ishibashi, S.; Sasamoto, R.; Nasuno, Y. & Ishikawa, A. (2004). A working AUV for scientific research, *OCEANS '04. MTT/IEEE TECHNO-OCEAN '04*, Vol. 2, pp. 863 - 868, 9-12 Nov. 2004.
- Young, C.; Fletcher, B.; Buescher, J.; Whitcomb, L.L.; Yoerger, D.; Bowen, A.; McCabe, R. Heintz, M.; Fuhrmann, R.; Taylor, C. & Elder, R. (2006). Field Tests of the Hybrid Remotely Operated Vehicle (HROV) Light Fiber Optic Tether, *Proceedings of*

OCEANS 2006. MTS/IEEE, pp. 1-6, ISBN: 1-4244-0115-1, Boston, MA, USA, Sept. 2006.

Zitnick, C. & Kanade, T. (1999). A Cooperative Algorithm for Stereo Matching and Occlusion Detection, *Tech. report CMU-RI-TR-99-35, Robotics Institute, Carnegie Mellon University*, October, 1999.

IntechOpen

IntechOpen



Underwater Vehicles

Edited by Alexander V. Inzartsev

ISBN 978-953-7619-49-7

Hard cover, 582 pages

Publisher InTech

Published online 01, January, 2009

Published in print edition January, 2009

For the latest twenty to thirty years, a significant number of AUVs has been created for the solving of wide spectrum of scientific and applied tasks of ocean development and research. For the short time period the AUVs have shown the efficiency at performance of complex search and inspection works and opened a number of new important applications. Initially the information about AUVs had mainly review-advertising character but now more attention is paid to practical achievements, problems and systems technologies. AUVs are losing their prototype status and have become a fully operational, reliable and effective tool and modern multi-purpose AUVs represent the new class of underwater robotic objects with inherent tasks and practical applications, particular features of technology, systems structure and functional properties.

How to reference

In order to correctly reference this scholarly work, feel free to copy and paste the following:

Hiroshi Yoshida (2009). Fundamentals of Underwater Vehicle Hardware and Their Applications, Underwater Vehicles, Alexander V. Inzartsev (Ed.), ISBN: 978-953-7619-49-7, InTech, Available from:
http://www.intechopen.com/books/underwater_vehicles/fundamentals_of_underwater_vehicle_hardware_and_their_applications

INTECH
open science | open minds

InTech Europe

University Campus STeP Ri
Slavka Krautzeka 83/A
51000 Rijeka, Croatia
Phone: +385 (51) 770 447
Fax: +385 (51) 686 166
www.intechopen.com

InTech China

Unit 405, Office Block, Hotel Equatorial Shanghai
No.65, Yan An Road (West), Shanghai, 200040, China
中国上海市延安西路65号上海国际贵都大饭店办公楼405单元
Phone: +86-21-62489820
Fax: +86-21-62489821

© 2009 The Author(s). Licensee IntechOpen. This chapter is distributed under the terms of the [Creative Commons Attribution-NonCommercial-ShareAlike-3.0 License](#), which permits use, distribution and reproduction for non-commercial purposes, provided the original is properly cited and derivative works building on this content are distributed under the same license.

IntechOpen

IntechOpen