

# We are IntechOpen, the world's leading publisher of Open Access books Built by scientists, for scientists

4,800

Open access books available

122,000

International authors and editors

135M

Downloads

Our authors are among the

154

Countries delivered to

TOP 1%

most cited scientists

12.2%

Contributors from top 500 universities



WEB OF SCIENCE™

Selection of our books indexed in the Book Citation Index  
in Web of Science™ Core Collection (BKCI)

Interested in publishing with us?  
Contact [book.department@intechopen.com](mailto:book.department@intechopen.com)

Numbers displayed above are based on latest data collected.

For more information visit [www.intechopen.com](http://www.intechopen.com)



# Design Fundamentals and Advanced Techniques of RFID Antennas

Sungtek Kahng  
University of Incheon  
South Korea

## 1. Introduction

The demand on the automated supply chain and logistics has been pervasive, aiming to replace the tedious bar-code labeling, and has driven an increasing number of research activities on the RFID to alternative and trustworthy solutions. The RFID takes the reader-and-tag paradigm where the interrogator(reader) uses its 'remote' correspondent(tag)s. To be sure about the reliable performance of an RFID system, though microelectronics for chip making and data acquisition are important, the antenna technologies for excellent wireless linkage have highly critical importance.

When it comes to the tag and reader antennas for the RFID, designers adopt the concept imitating the radar technology in which the reader transmits a signal to a tag and the tag sends back its recorded data to the reader. The considerations must be made with the frequency, the impedance of the chip and antenna, the constraints(overall size), the radiation pattern and gain, the reading range, and the tagged objects(geometry and materials). Especially, care must be taken of with regard to the realistic environment that affects the near-field region of reader- and tag antennas and the operational quality of the overall RFID system[1-10].

Prior to the design of the reader- and tag antennas, the basics of antennas are tapped to see the way the electromagnetic fields propagate from radiators for higher frequency regimes (860MHz-960MHz) along with the magnetic- and electric coupling mechanisms for lower frequency(125kHz-134kHz). And then as the first place in the UHF-band RFID antenna design, the impedance matching techniques are addressed with a variety of antenna structures apt to the size reduction and acceptable efficient radiation. In particular, a couple of design examples are practiced with the illustrations obtained by the electromagnetic field solver. As a matter of course, this is accompanied by the considerations of the tags' materials and relevant electromagnetic properties. And the advanced design schemes are introduced with the on-going topics such as multiple aspects in band and polarization as well as near-field UHF tags. It is followed by the remarks on the testing methodology of tag antennas' input impedance, gain, pattern and reading distance. Finally, conclusions are presented.

## 2. Principles of radio frequency identification & ABC's of RFID antennas

An RFID system comprises a reader and one tag or more. This is illustrated in Figure 1.

Source: Development and Implementation of RFID Technology, Book edited by: Cristina TURCU, ISBN 978-3-902613-54-7, pp. 554, February 2009, I-Tech, Vienna, Austria

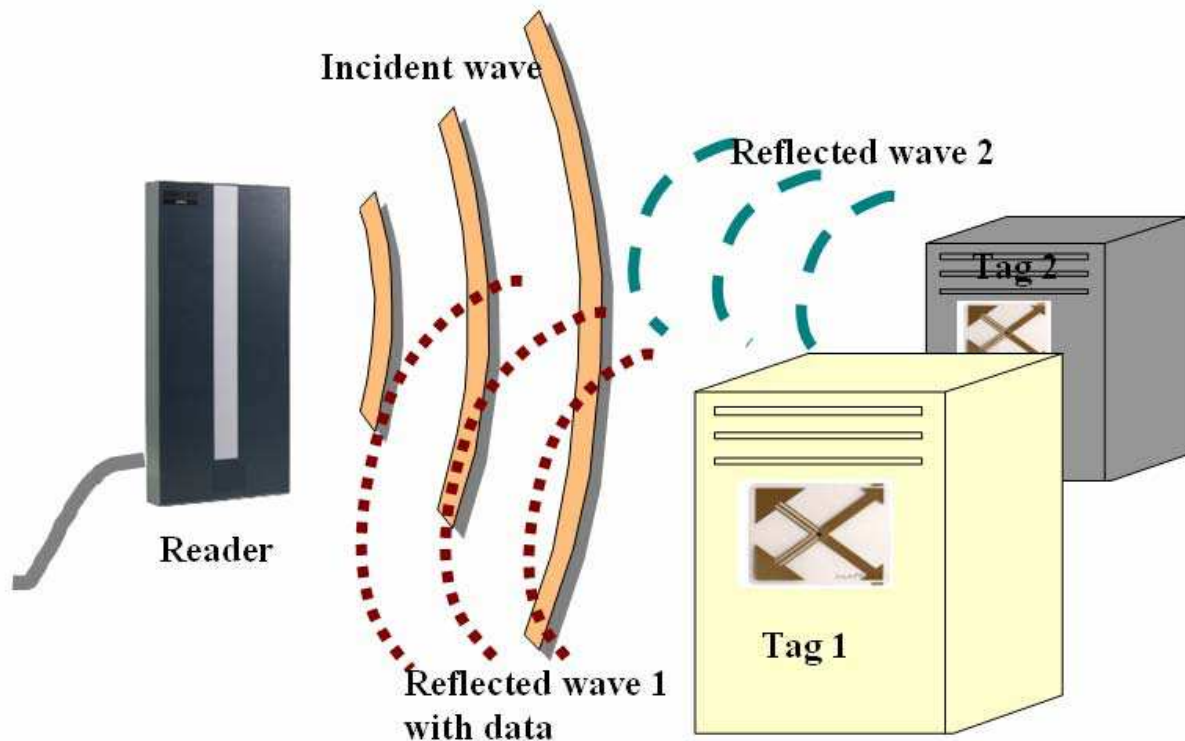

Fig. 1. Sketch of a typical RFID System

The reader sends the signal at a frequency of interest to its neighbor objects with the tags on. Each tag, which is composed of a chip and an antenna, should be responsive as efficiently as possible to the incoming RF signal. The received electromagnetic energy activates the chip through the antenna and the chip provides the stored information for the antenna sends the data conveyed in the RF energy back to the reader.

The interaction between the reader and the tag can be interpreted as what is made in the radar system. Actually, the things like the power, antenna gain and read-range of the antennas at step number 1 in the design are expressed by the so-called 'tag equation' looking pretty much the same as the formula of the radar cross-section(RCS). The only difference between the radar and RFID systems is that the RFID system concerns the impedance matching problem of the target, while the radar system doesn't. In other words, the target in the RFID application is an antenna which is not a simple scatterer.

Assuming the impedance and polarization matched between the reader and the tag, we derive the formulae on the power received by the chip in the tag and the power the reader will get as the re-radiation from the tag. We find them useful in determining the values of the antenna gains for the reader and the tag and input power at the beginning of the RFID system design.

$$P_L = P_{in} G_{reader} G_{tag} \lambda^2 / (4\pi R)^2 \quad (1)$$

$$P_{rec} = P_{in} G_{reader}^2 G_{tag}^2 \lambda^4 / (4\pi R)^4 \quad (2)$$

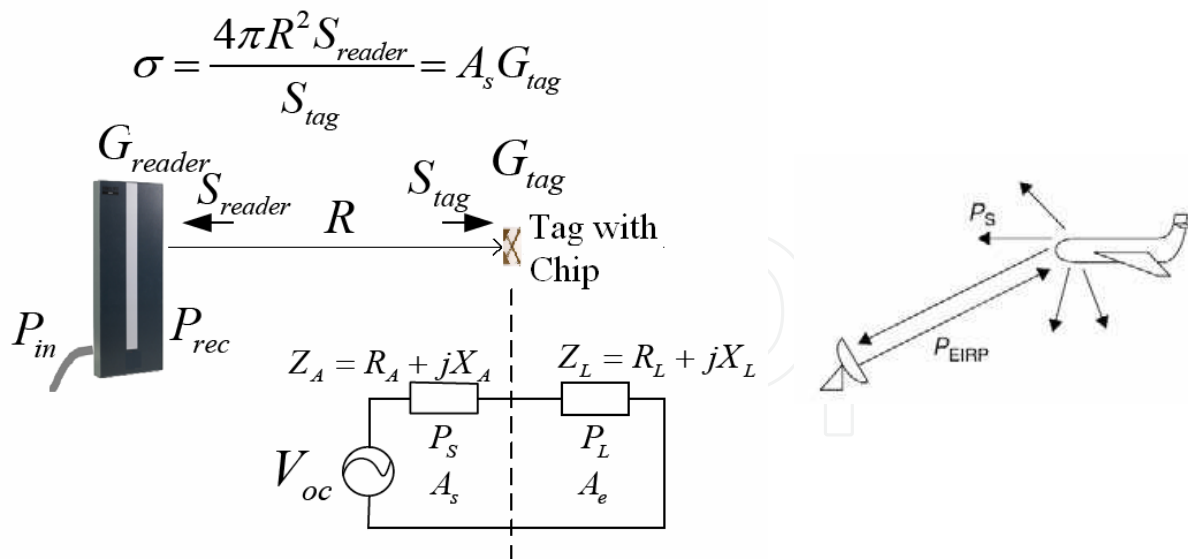

Fig. 2. Tag equation of an RFID system analogous to a radar cross-section problem where the symbols mean

- $A_s$  : effective scattering aperture
- $A_e$  : effective receiving aperture
- $P_L$  : power received by the chip in the tag
- $P_{rec}$  : power received by the reader(via the re-radiation)
- $S_i$  : power density at  $i$
- $G_i$  : Antenna  $i$ 's gain
- $\sigma$  : radar cross-section

If mismatch happens to the impedance and polarization, the equations are modified with the factors  $p$  (polarization mismatch factor) and  $\Gamma_{tag}$  (reflection coefficient from the tag).

$$P_L = (1 - |\Gamma_{tag}|^2) \cdot p \cdot P_{in} G_{reader} G_{tag} \lambda^2 / (4\pi R)^2 \tag{3}$$

$$P_{rec} = p \cdot P_{in} G_{reader}^2 G_{tag}^2 \lambda^4 / (4\pi R)^4 \tag{4}$$

Using the power received by the tag and the reader, we can predict the read range as follows.

$$R_{max} = \min[\{p \cdot P_{in} G_{reader}^2 G_{tag}^2 \lambda^4 / (4\pi)^4\}^{0.25}, \sqrt{(1 - |\Gamma_{tag}|^2) \cdot p \cdot P_{in} G_{reader} G_{tag} \lambda / (4\pi)}] \tag{5}$$

Seeing this formula, it is clear to see what kind of parameter determines how far the RFID communication covers.

Now, let us look at the representative kinds of antennas that are frequently used and designed sticking to the specifications generated for the RFID system having  $R_{max}$  along with  $P_L$  and  $P_{rec}$  above. Firstly, there are tags and readers utilizing the magnetic coupling as follows.

The magnetic coupling is represented by  $B_2(I_1)$  which means the magnetic flux density into loop 2 as the tag, stimulated by the current of the loop 1 ' $I_1$ ' as the reader. The tags based on the magnetic coupling are used mostly in the LF(Low Frequency), say, 125kHz or 134kHz

for the near-field RFID like the animal tracking or access control. The coil tag can be sometimes used in a High Frequency (HF regime) like 13.56MHz.

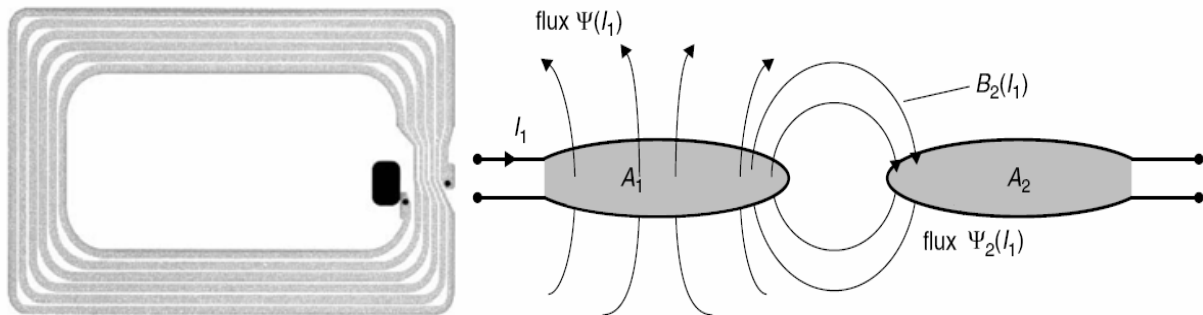

Fig. 3. Coil tag and magnetic coupling between two loops

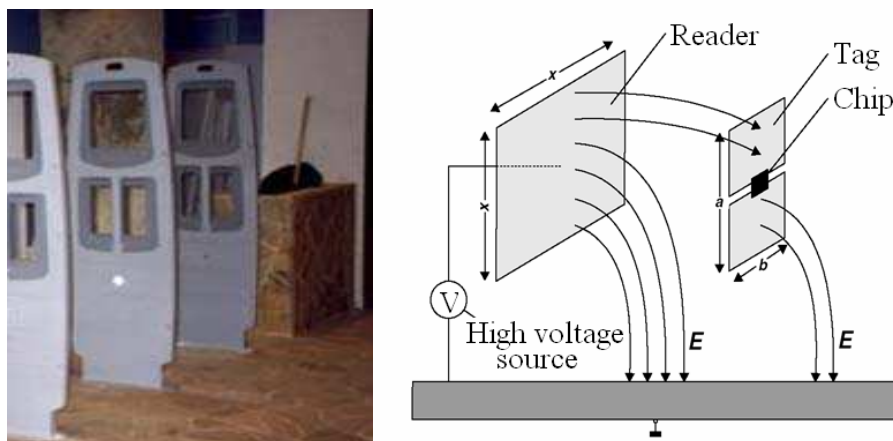

Fig. 4. Electric coupling based tags and electric field coupling in the system

As is seen from the left picture in Figure 4, the metal planes having different voltages form the electric field in between. In other words, the reader of the higher voltage is coupled with the tag of the lower voltage through the electric field as we see the right picture in Figure 4. This coupling is adopted for the LF RFID system such as theft prevention in a library.

For the RFID communication service above 30MHz, mostly the UHF band, instead of the magnetic or electric field coupling, the electromagnetic wave propagation is preferred to have an increased read-range and capacity of information exchange.

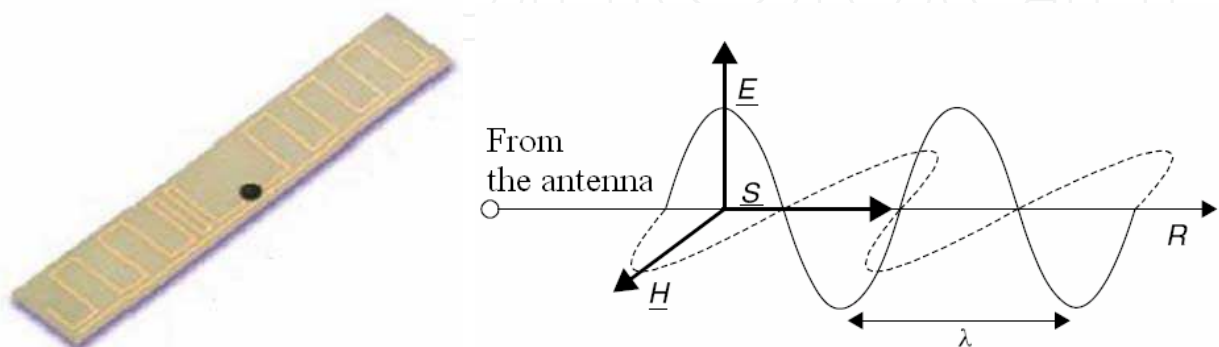

Fig. 5. A UHF RFID tag antenna and electromagnetic wave propagation

With the increasing frequency, the electric and magnetic fields are no more independent from each other, but become incorporated described by the Maxwell equations where the time-varying electric field leads to the space-varying magnetic field and vice versa. And they move in the air, carrying the power.

### 3. Conjugate impedance matching

The impedance matching condition has been addressed very essential regarding the quality of the RFID system with the power received by the tag and reader. In Figure 2, a simplified transmission line models the linkage of the reader antenna and the tag with the chip. The transmission line circuit is connected to the input impedance of the reader antenna and the tag, and it is ideal for the overall circuit to be matched to both the source and load. However, in practice, the impedance matching for the reader and the tag is split. And for the reader alone, the impedance matching is made to remove the reflection to the antenna from the feeding circuit. Simultaneously, as just for the tag, the impedance of the antenna should be matched with that of the chip. Though the matching problems of the reader and the tag are treated separately, the schemes are the same. Hence, throughout this section, we talk about the impedance matching techniques (Shunt stub matching, Inductive loop matching and Nested slot matching) for only the tag.

#### 3.1 Shunt stub(T-) matching

The chip has the capacitive impedance which has the negative imaginary term. In order to have the best tag antenna efficiency, the input impedance of the antenna should have the inductive reactance, which cancels the capacitance reactance of the chip, when they are connected.

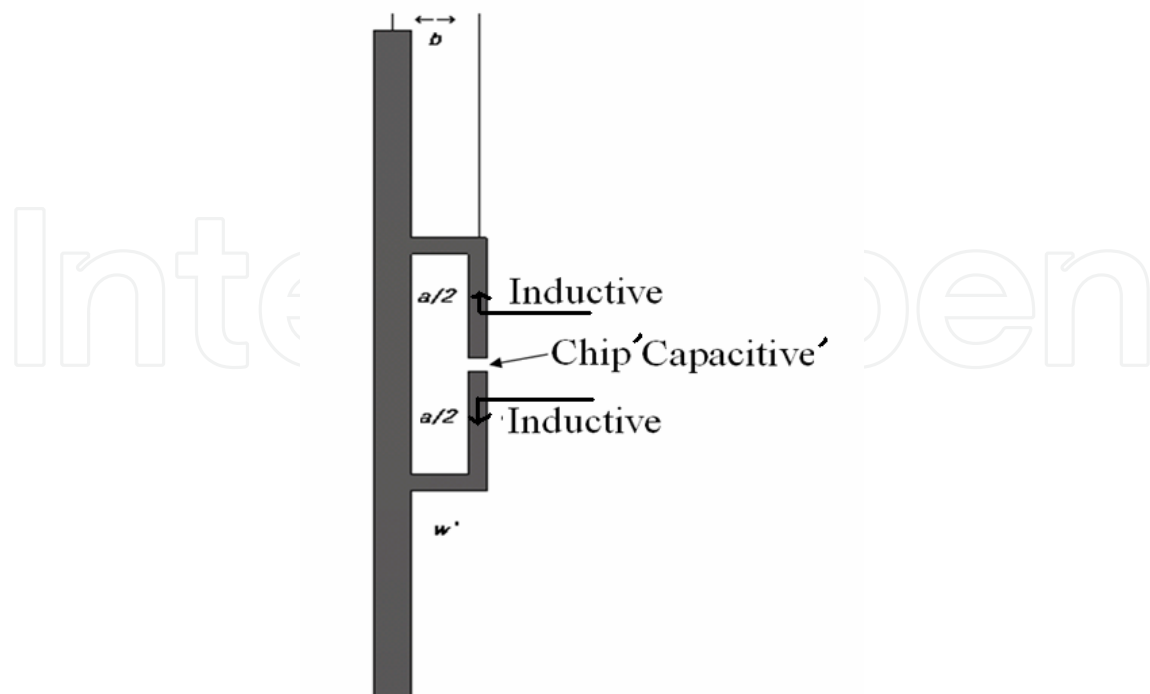

Fig. 6. Inductive stub matching of the antenna against the capacitive chip

As an example, the chip has the negative reactance  $-j100$  in Figure 7. For the total input impedance of the tag to have only the real term  $70\Omega$ , the antenna with the stub should have the positive reactance  $+j100$ .

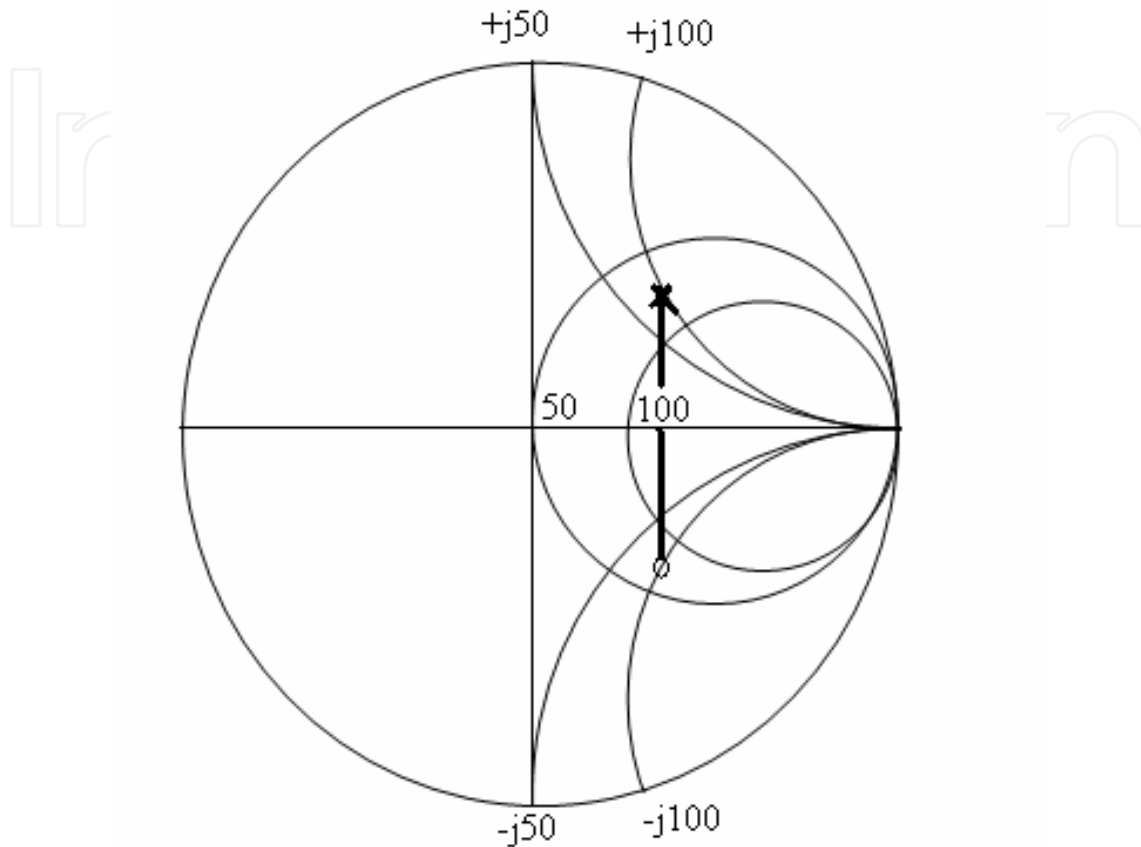

Fig. 7. Capacitive Chip( $Z_L=70-j100$ , 'O') meets the antenna of the Inductive reactance('X')

In reality, it is not true that all the capacitive reactance results from only the chip and the tag designers can use the antenna size as large as they want. Almost all the RFID tag antenna designs pursue the way they fit into the small spots specified on an object and this ends up with the decrease in the size from the original resonance length for the antenna radiation at the operating frequency. When the antenna size becomes smaller from the resonance(radiation) length, its input impedance becomes capacitive, namely, having the negative reactance or negative imaginary part. So the impedance matching must be carried out to consider the capacitive reactance due to not only the chip but also the shortened antenna.

### 3.2 Inductive loop matching

Related to the shunt stub matching, the inductive reactance of the antenna is needed to play the countermeasure of the capacitive reactance of a chip. This inductive reactance or the positive imaginary part of the antenna's input impedance can be alternatively introduced by the following configuration.

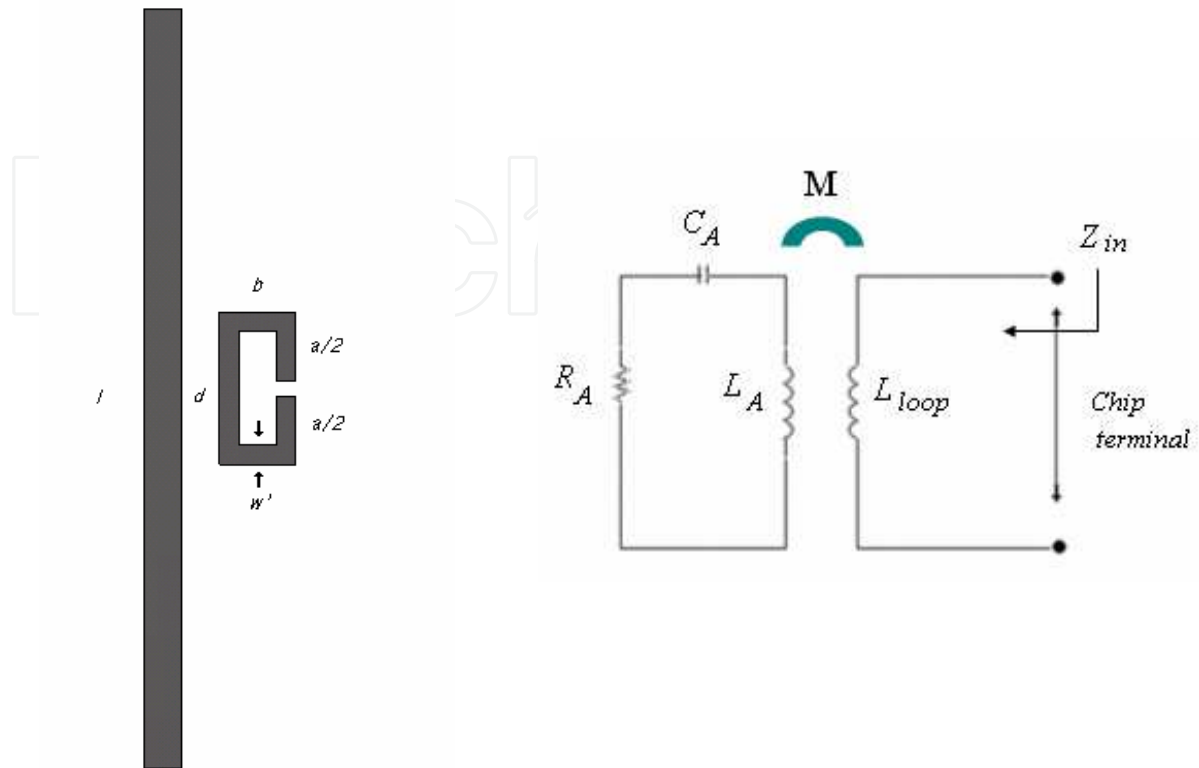

Fig. 8. An inductive loop near the main radiator and a circuit interpretation

Seeking a way to increase the inductive reactance, there are a variety of methods, and a metal loop and magnetic coupling can be used. If the spacing between the loop and the nearby radiator is not too small, the magnetic field from the loop forms the linkage to the radiator and it plays an important role in beefing up the imaginary part of the antenna's input impedance. The magnetic flux is represented by the transformer that renders the input impedance  $Z_{in}$

$$Z_{in} = Z_{loop} + (2\pi f M)^2 / Z_A \quad (6)$$

where  $Z_{loop}$  is  $j2\pi f L_{loop}$ .

It is a matter of course that  $M$  is the mutual inductance between the loop and the main radiator. And it should be noted that on the contrary to the shunt stub- or T- matching, the inductive loop matching is suitable for the case the input impedance's real term is far smaller than the imaginary term.

### 3.3 Nested slot matching

The former two matching approaches have added another metal geometry to the main one to use the concept of induction. However, a different scheme can be tried and practiced by forming slots inside the main radiator. For a short while, let us remind ourselves of the meaning of a slot[9]. A slot is an aperture or a window made by removing the area from the solid metal surface. For better understanding, the following figure has the slot area nested by the rest of the metal patch.



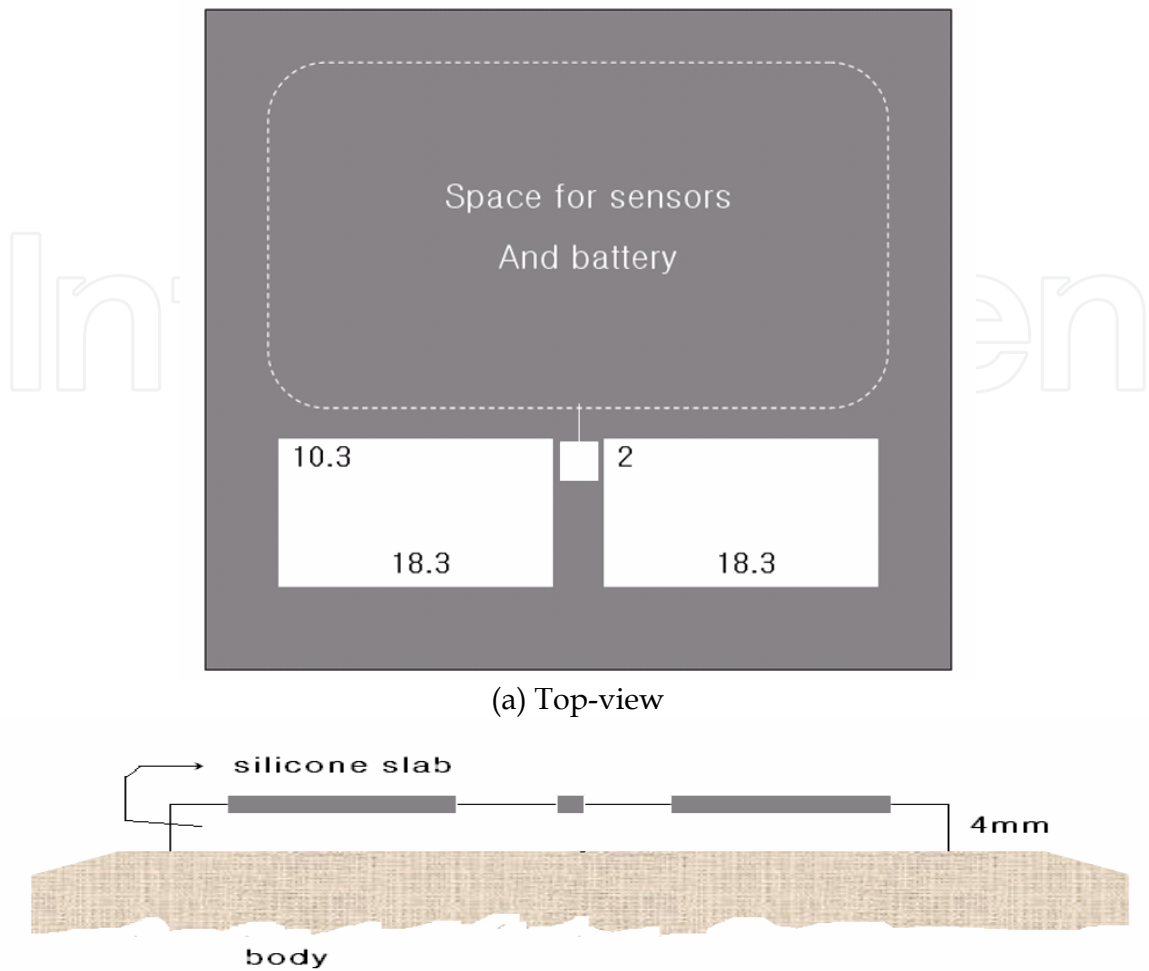

(b) Side-view showing different material layers(Air, Silicon slab, Metal patch, and Metal body)

Fig. 9. Top-and side-views of a metal patch with the nested slot

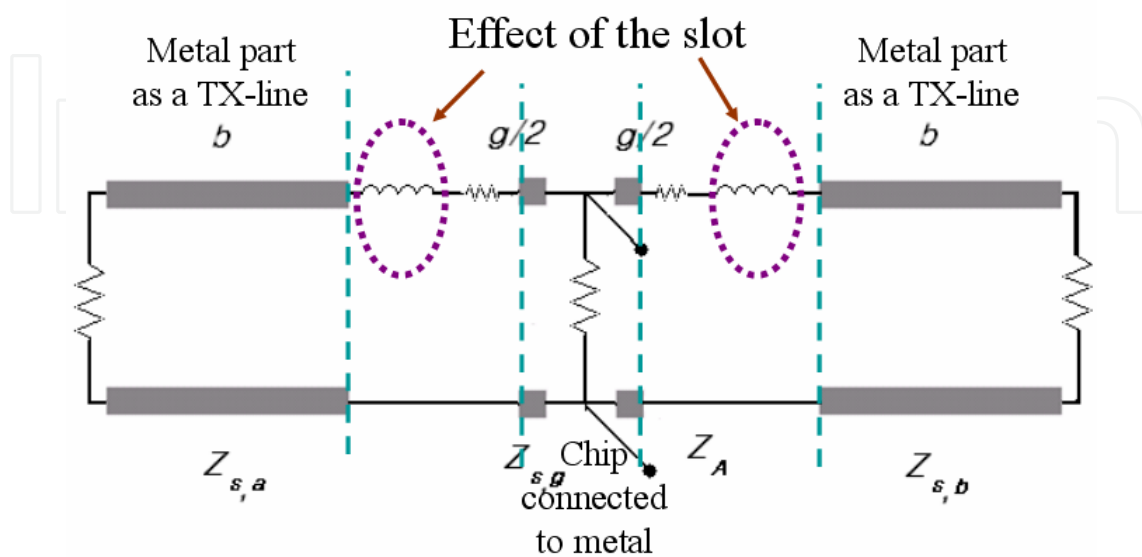

Fig. 10. Circuit model of the metal patch with the nested slot in Figure 9

The formation of the slot disturbs the surface electric current path of the original rectangular patch. The current starting from the driving point(chip connecting point) will flow along longer paths such as the edges of the slot. Especially, when the operating frequency is high enough, say, UHF or GHz band, each piece or segment( $\Delta L$ ) of a conduction current path the current is equivalent to  $j2\pi fL_{loop}\Delta L$  or the inductance.

As is shown in Figure 10, the inductance between the TX(transmission)-lines due to the slot can be used to cancel the capacitance of the chip. It is noteworthy that the real term of the impedance is as large as the imaginary term like the shunt stub matching case

#### 4. Size reduction techniques

In the design of the RFID antennas, the size of the geometry is treated equally important as the impedance matching, since they tend to look for light, low-profiled and portable RFID equipment. Owing to the modern antenna technologies including materials, manufacturing, and electromagnetic field prediction, the size of an antenna has been successfully minimized, when it is needed to place in a portable device. In this section two ways of size reduction are presented.

##### 4.1 Meandering

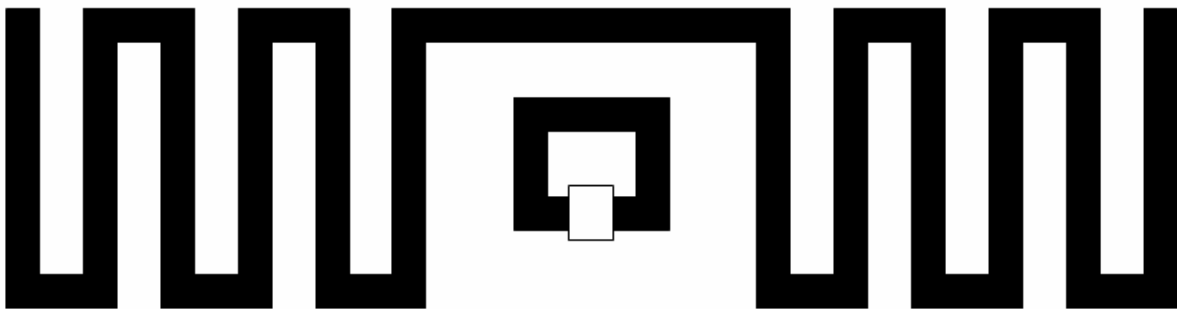

Fig. 11. Inductive loop with a meandered conducting wire

Figure 11 shows the inductive loop coupled with the meandered line[5-6]. Just remember the loop driven by the chip could bring the inductive reactance when it has the nearby main radiator which is as long as half-wavelength. Considering the straight main radiator stretches over the required area, the shape can be changed by meandering to fit the space or within the boundary, while its radiation and impedance performance meets the specifications. We will see later the design steps of a meandered tag antenna.

##### 4.2 Inverted-F structure[7]

With the tendency that mobile phones are wanted to be less bulky, the wire antenna such as whipped(monopole ) antenna is disappearing and the inverted-F type has been preferred from the outset of its invention. The word 'inverted-F' itself comes from its geometrical appearance that two conductors touch the metal ground and support a metal planar radiator. The two conductors are the feed and the shorting pin. The positions of the two conductors determine the impedance and bandwidth as well as the field pattern.

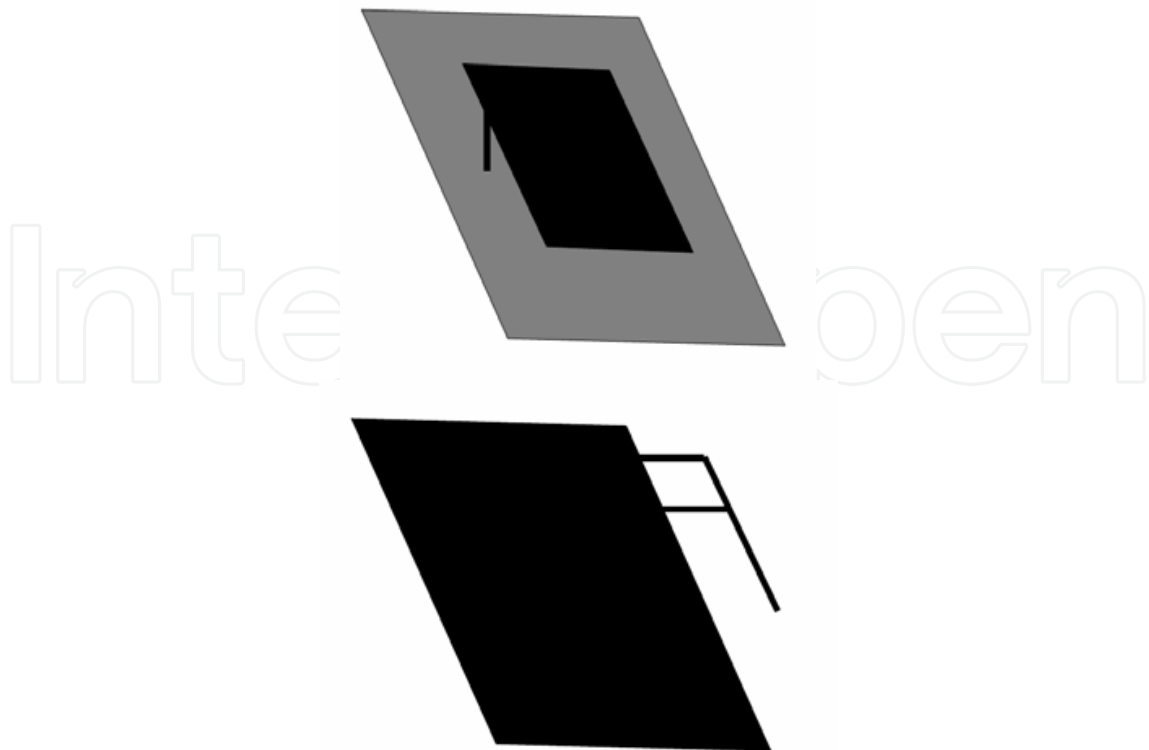

Fig. 12. Inverted-F antenna and its coplanar version

Seeing the structures in Figure 12, on your left side, the typical inverted-F antenna where the main planar radiator resides on the dielectric (or air) substrate, and on the right reversed letter 'F', which is the wire version of the inverted-F antenna, is attached to the ground on the same layer (coplanar). Basically, these antennas belong to the quarter-wavelength or monopole antenna. But the radiator is placed near the ground to keep a low-profile compared to the monopole which has its top end up in the air.

## 5. Other issues

As the wireless technologies are getting developed rapidly, the demands on the challenging requirements become more and more complicated such as the circular- or dual-polarization, the dual-band and so and so forth.

As we have seen before, the polarization mismatch lowers the power received by the tag and the reader and the resultant degradation of the RFID system's quality, with equations 3 and 4. This is why the antennas for the tag and the reader are designed to have circular polarization which is less vulnerable to the mismatched polarization, or dual polarization which provides polarization diversity.

Regarding the frequency regimes adopted for the RFID applications, there exist a number of bands [8-10]. Different countries have different RFID industrial standards and different frequency bands. After a product is made in one country, it is shipped to another and it is assumed to have the RFID tag working at one frequency band. The tracking of the product will be failed as soon as it disembarks. In order to avoid this trouble, antennas are wanted to show dual-band operations. The following is an example of a dual-band RFID tag antenna.

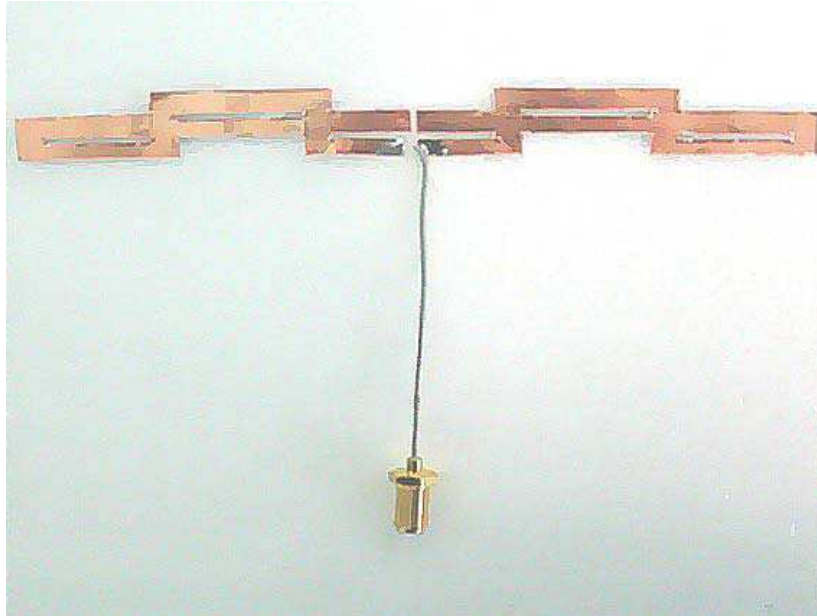

Fig. 13. A dual-band dipole antenna[11]

In Figure 13, the collinear-type antenna has up-and-down metal segments and slots together. Radiation occurs at two frequency bands 900MHz-UHF band and 2.4GHz-band. The lower band radiation results from the surface current resonant on the metal segments and the slots account for the higher band radiation.

## 6. Design example

We are going through the design procedure for a meander wire antenna with a parasitic element, using FEKO™ a full-wave EM simulator[11].

Step 1) Define Variables and Input Parameters

See Figure 14. Here, we set the operating frequency( = 916MHz), BW, constitutive parameters, etc

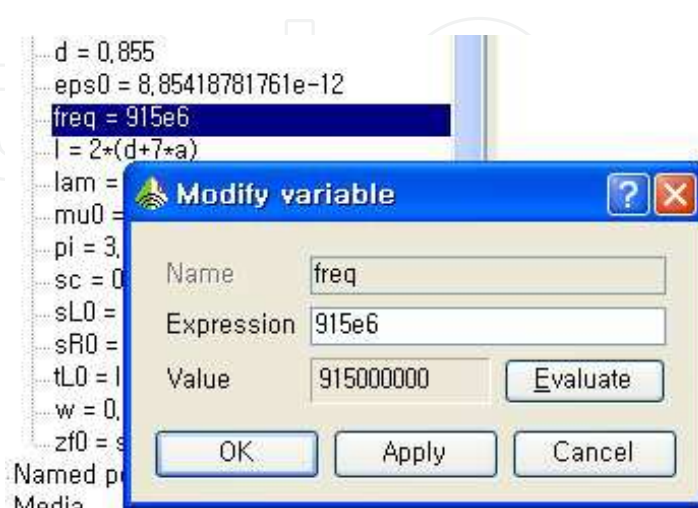

Fig. 14. Defining Variables and Input Parameters

```

Variables
a = 0,57
b = 1,33
C_l = 1/(434*2*pi*905e6)
c0 = 1/sqrt(eps0*mu0)
d = 0,855
eps0 = 8,85418781761e-12
freq = 915e6
l = 2*(d+7*a)
lam = c0/freq/sc
mu0 = pi*4e-7
pi = 3,14159265358979323846
sc = 0,01
sL0 = min(tL0,1,5*w)
sR0 = w/4
tL0 = lam/20
w = 0,0665
zf0 = sqrt(mu0/eps0)

```

Fig. 15. Defined Variables and Input Parameters

Step 2) Draw the Geometry

Draw the shape of the antenna on your mind.

See Figure 16.

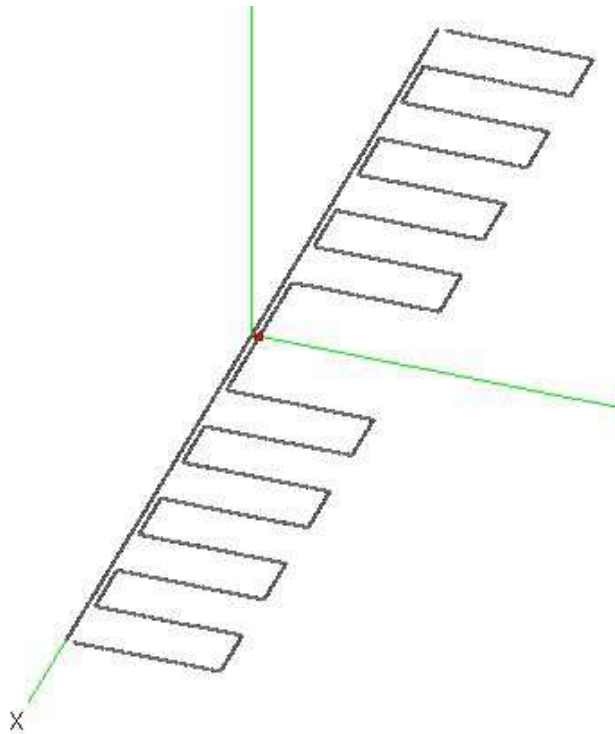

Fig. 16. Drawing the meander line

Step 3) Set the port or voltage source

Set the position of the driving point (port) and set the type such voltage gap source

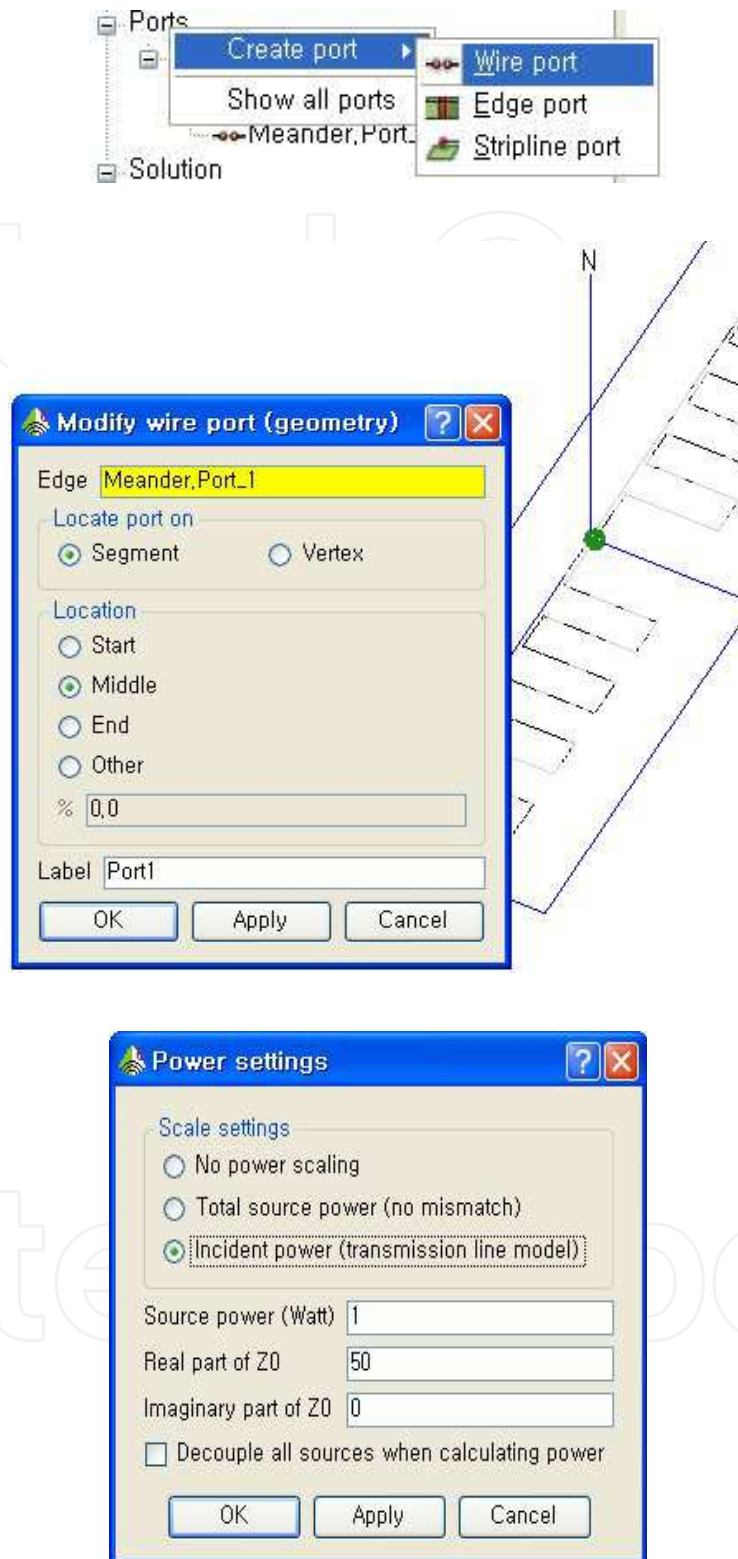

Fig. 17. Define the port and set the type

Step 4) Set the condition for the far-field calculation

Determine the conditions of the far-field such as the pattern and the boundary of simulation

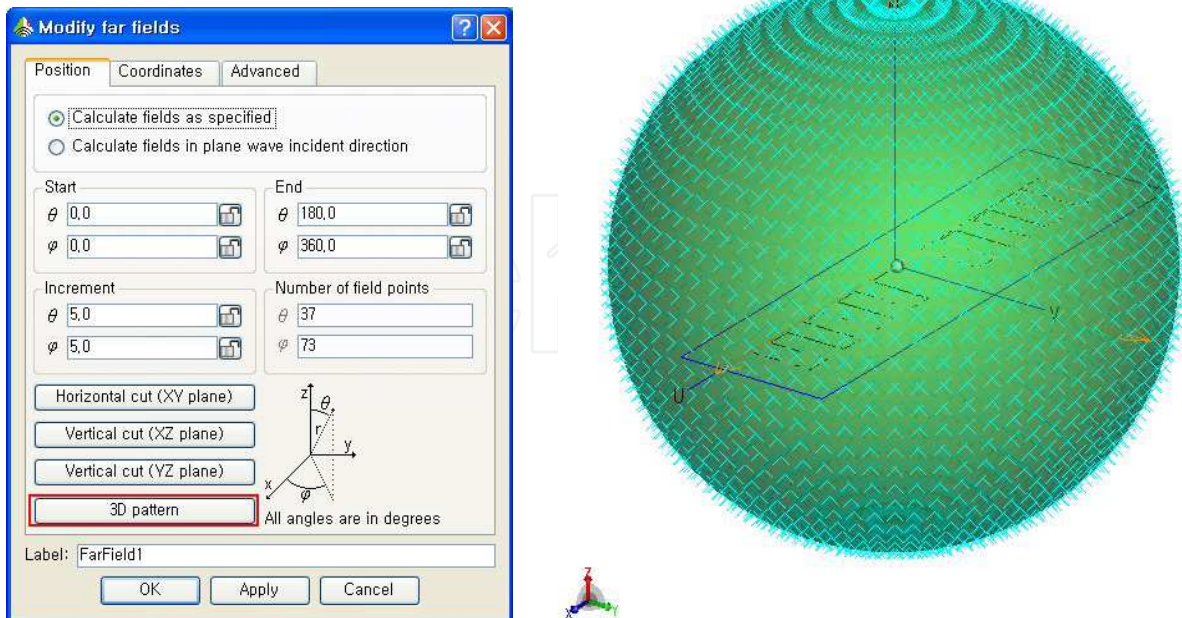

Fig. 18. Determine the conditions for the far-zone field simulation

Step 5) Set the condition for the meshing for the full-wave calculation

Determine the conditions of the meshing for the 3D full-wave calculation

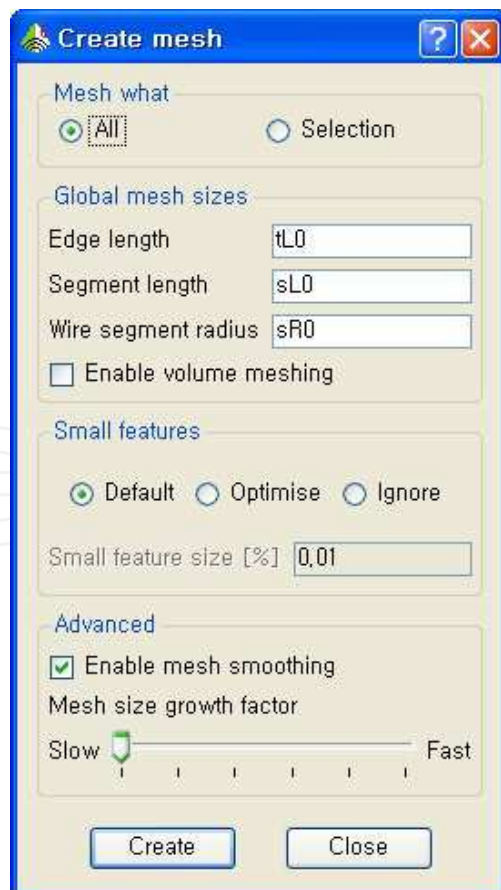

Fig. 19. Set the meshing condition for the meshing

Step 6) Running the program and getting the results

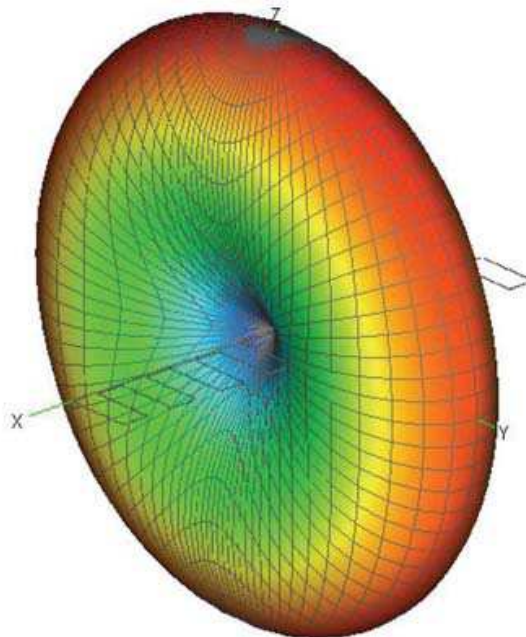
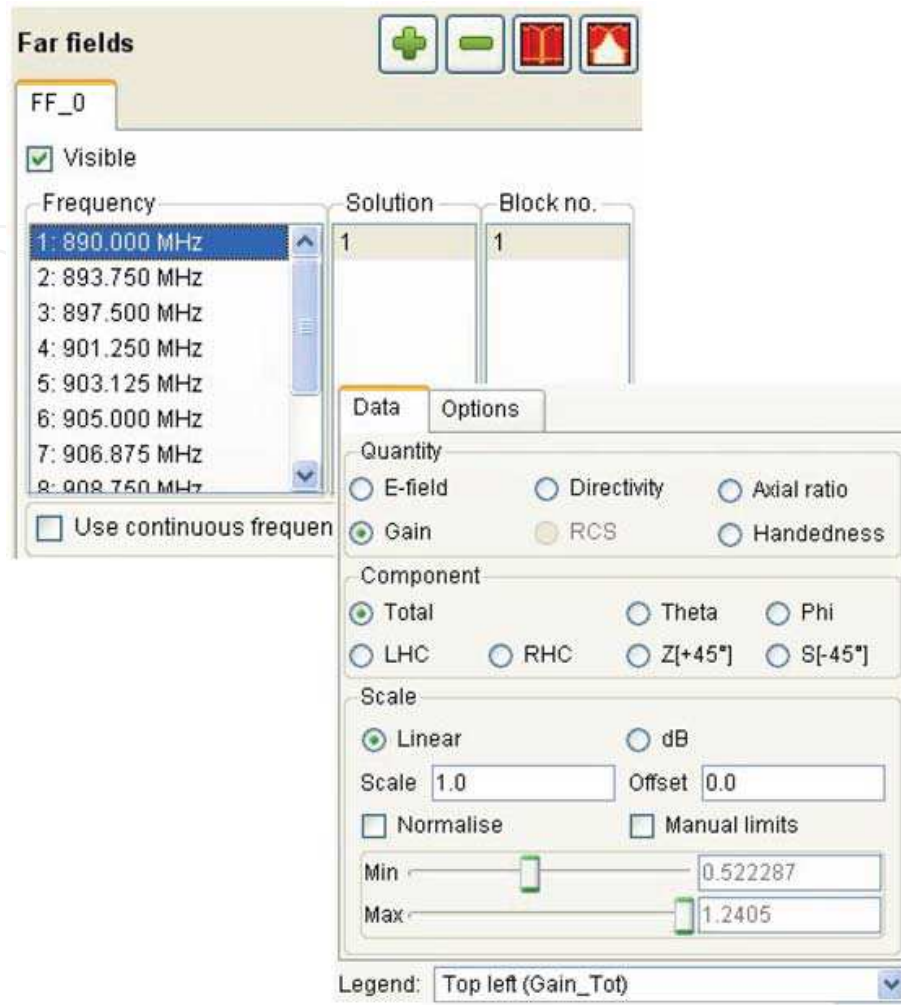

Fig. 20. Acquiring the data we need such as the 3D far-field pattern



## 7. References

- [1] J. Curty, N. Joehl, C. Dehollain and M. J. Delercq, "Remotely Powered Addressable UHF RFID Integrated System," *IEEE Journal of Solid-State Circuits*, 40, 11, November 2005, pp. 2193-2202.
- [2] S. Basat, S. Bhattachary, A. Rida, S. Johnston, L. Yang, M. M. Tentzeris and J. Laskar, "Fabrication and Assembly of a Novel High-Efficiency UHF RFID Tag on Flexible LCP Substrate," *Electronic Components and Technology Conference*, May-Jun 2006, pp. 1352-1355.
- [3] Marrocco G. (2007), RFID antennas for the UHF remote monitoring of Human subjects, *IEEE Transaction on. Antennas and Propagation*, Vol.55, N. 6, June 2007, pp. 1862-1870
- [4] Y. Lee, "Antenna Circuit Design for RFID Applications," Microchip Technology Inc., Application Note AP710, 2003, available at <http://ww1.microchip.com/downloads/en/AppNotes/00710c.pdf>.
- [5] W. Choi, H. W. Son, C. Shin, J. H. Bae and G. Choi, "RFID Tag Antenna with a Meandered Dipole and Inductively Coupled Feed," *IEEE International Symposium on Antennas and Propagation*, Albuquerque, NM, July 2006, pp. 619-622.
- [6] S. A. Delichatsios, D. W. Engels, L. Ukkonen and L. Sydanheimo, "Albano Multidimensional UHF Passive RFID Tag Antenna Designs," *Int. J. Radio Frequency Identification Technology and Applications*, , 1, January 2006, pp. 24-40.
- [7] C. Cho, H. Choo and I. Park, "Design of Novel RFID Tag Antennas for Metallic Objects," *IEEE International Symposium on Antennas and Propagation Digest*, Albuquerque, NM, July 2006, pp. 3245-3248.
- [8] M. Hirvonen, K. Jaakkola, P. Pursula and J. Saily, "Dual-Band Platform Tolerant Antennas for Radio-Frequency Identification," *IEEE Transactions on Antennas and Propagation*, AP-54, 9, September2006, pp. 2632-2636.
- [9] S. Nambi and S. M. Wentworth, "5.8 GHz Dual-Polarized Aperture-Coupled Microstrip Antenna," *IEEE International Symposium on Antennas and Propagation Digest*, Washington, DC, July 2005, pp. 235-238.
- [10] S. Jeon, Y. Yu, S. Kahng, J. Park, N. Kim and J. Choi, "Dual-Band Dipole Antenna for ISO 18000-6/ISO 18000-4 Passive RFID Tag Applications," *IEEE International Symposium on Antennas and Propagation Digest*, Albuquerque, NM, July 2006, pp. 4285-4288.
- [11] EM Software & Systems-S.A. (Pty) Ltd., FEKO User's Manual, Suite 5.1, Stellenbosch, South Africa. December 2005, available at <http://www.feko.info>



## **Development and Implementation of RFID Technology**

Edited by Cristina Turcu

ISBN 978-3-902613-54-7

Hard cover, 450 pages

**Publisher** I-Tech Education and Publishing

**Published online** 01, January, 2009

**Published in print edition** January, 2009

The book generously covers a wide range of aspects and issues related to RFID systems, namely the design of RFID antennas, RFID readers and the variety of tags (e.g. UHF tags for sensing applications, surface acoustic wave RFID tags, smart RFID tags), complex RFID systems, security and privacy issues in RFID applications, as well as the selection of encryption algorithms. The book offers new insights, solutions and ideas for the design of efficient RFID architectures and applications. While not pretending to be comprehensive, its wide coverage may be appropriate not only for RFID novices but also for experienced technical professionals and RFID aficionados.

### **How to reference**

In order to correctly reference this scholarly work, feel free to copy and paste the following:

Sungtek Kahng (2009). Design Fundamentals and Advanced Techniques of RFID Antennas, Development and Implementation of RFID Technology, Cristina Turcu (Ed.), ISBN: 978-3-902613-54-7, InTech, Available from: [http://www.intechopen.com/books/development\\_and\\_implementation\\_of\\_rfid\\_technology/design\\_fundamentals\\_and\\_advanced\\_techniques\\_of\\_rfid\\_antennas](http://www.intechopen.com/books/development_and_implementation_of_rfid_technology/design_fundamentals_and_advanced_techniques_of_rfid_antennas)

# **INTECH**

open science | open minds

### **InTech Europe**

University Campus STeP Ri  
Slavka Krautzeka 83/A  
51000 Rijeka, Croatia  
Phone: +385 (51) 770 447  
Fax: +385 (51) 686 166  
[www.intechopen.com](http://www.intechopen.com)

### **InTech China**

Unit 405, Office Block, Hotel Equatorial Shanghai  
No.65, Yan An Road (West), Shanghai, 200040, China  
中国上海市延安西路65号上海国际贵都大饭店办公楼405单元  
Phone: +86-21-62489820  
Fax: +86-21-62489821

© 2009 The Author(s). Licensee IntechOpen. This chapter is distributed under the terms of the [Creative Commons Attribution-NonCommercial-ShareAlike-3.0 License](#), which permits use, distribution and reproduction for non-commercial purposes, provided the original is properly cited and derivative works building on this content are distributed under the same license.

IntechOpen

IntechOpen