

We are IntechOpen, the world's leading publisher of Open Access books Built by scientists, for scientists

4,800

Open access books available

122,000

International authors and editors

135M

Downloads

Our authors are among the

154

Countries delivered to

TOP 1%

most cited scientists

12.2%

Contributors from top 500 universities



WEB OF SCIENCE™

Selection of our books indexed in the Book Citation Index
in Web of Science™ Core Collection (BKCI)

Interested in publishing with us?
Contact book.department@intechopen.com

Numbers displayed above are based on latest data collected.

For more information visit www.intechopen.com



High-Speed Adaptive Control Technique Based on Steepest Descent Method for Adaptive Chromatic Dispersion Compensation in Optical Communications

Ken Tanizawa and Akira Hirose

*Department of Electronic Engineering, The University of Tokyo
Japan*

1. Introduction

The traffic volume of the data transmission is increasing each year with the explosive growth of the Internet. The networking technologies supporting the data transmission are optical fiber transmission technologies. In the physical layer, the networks are classified into three networks, the long-haul network that connects city to city, the metropolitan area network that connects the central station in the city to the neighboring base station, and the access network that connects the base station to the home. In order to adapt to the increase of the data transmission, we need to achieve high-speed transmission and increase the capacity of transmission in each network.

In the access network, many kinds of passive optical networks (PON) are studied to offer a high-speed access to the Internet at low cost. In the metropolitan area network, we contemplate the update of the network structure from the conventional peer-to-peer transmission to the ring or mesh structure for the high-capacity and highly reliable networks. In the long-haul network, the study on multilevel modulation such as the differential quadrature phase shift keying (DQPSK) is a recent popular topic for the high-capacity transmission because the multilevel modulation utilizing the phase information offers high-speed transmission without increasing the symbol rate. Other modulation and multiplexing technologies are also studied for the high-capacity networks. The orthogonal frequency division multiplexing (OFDM) is one of the wavelength division multiplexing methods and achieves high spectral efficiency by the use of orthogonal carrier frequencies. The optical code division multiple access (OCDMA) is a multiplexing technique in the code domain. These techniques are developed in the wireless communication and modified for the optical transmission technologies in these days.

In the long-haul and the metropolitan area networks whose transmission distance is over 10 km in 40 Gb/s, chromatic dispersion (CD) is one of the main factors which limits the transmission speed and the advances of the network structure. The CD is a physical phenomenon that the group velocity of light in the fiber depends on its wavelength (Agrawal, 2002). The CD causes the degradation of the transmission quality as the optical

signals having a spectral range are distorted by the difference of the transmission speed in the wavelength domain. The effect of dispersion increases at a rate proportional to the square of the bit-rate.

In the high-speed optical transmission over 40 Gb/s, we have to compensate for the CD variation caused by the change of strain and temperature adaptively in addition to the conventional static CD compensation because the dispersion tolerance is very small in such a high-speed transmission. Also, in metropolitan area networks employing reconfigurable networking technology such as the mesh or ring network, the transmission route changes adaptively depending on the state of traffic and the network failure. As the CD value depends on the length of the transmission fiber, we have to compensate for the relatively large CD variation caused by the change of the transmission distance.

With the aforementioned background, many researches and demonstrations have been conducted in the field of the adaptive CD compensation since around 2000 (Ooi et al., 2002; Yagi et al., 2004). The adaptive compensations are classified into two major groups, the optical compensations and the electrical compensations. In the electrical compensation, we utilize the waveform equalizer such as the decision feedback equalizer (DFE), the feed forward equalizer (FFE) or the maximum likelihood sequence equalizer (MLSE) after detection (Katz et al., 2006). These equalizers are effective for the adaptive CD compensation because they act as a waveform reshaping. The compensation based on DFE and FFE has advantages that the equalization circuit is compact and implemented at low cost. However, the compensation range is limited because the phase information of the received signal is lost by the direct detection. The MLSE scheme is very effective in 10 Gb/s transmission. However it is difficult to upgrade high bit-rate over 40 Gb/s because the scheme requires high-speed A/D converter in implementation.

In the optical domain, the adaptive CD compensation is achieved by the iterative feedback control of a tunable CD compensator with a real-time CD monitoring method as shown in Fig. 1. Many types of tunable CD compensators are researched and developed recently. The tunable CD compensator is implemented by the devices generating arbitral CD value. Also, many kinds of CD monitoring methods are studied and demonstrated for the feedback control of tunable CD compensators. While the compensation devices and the dispersion monitoring methods are studied with keen interest, the adaptive control algorithm, how to control the tunable CD compensator efficiently, has not been fully studied yet in the optical domain CD compensation. When the tunable CD compensator is controlled iteratively for the adaptive CD compensation, the control algorithm affects the speed of the compensation to a great degree as well as the response time of the compensation devices and the monitorings. Although the simple hill-climbing method and the Newton method are employed as a control algorithm in many researches and demonstrations, these algorithms are not always the best control algorithm for the adaptive CD compensation.

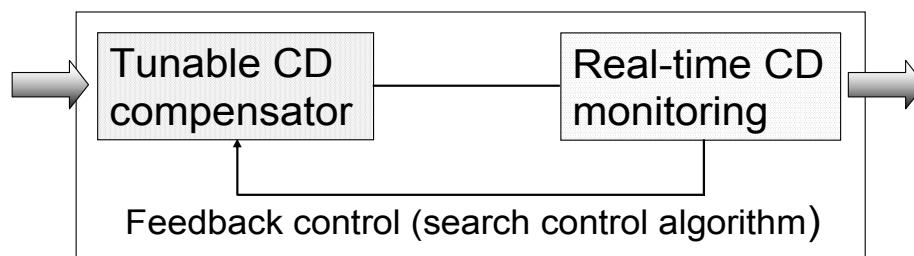

Fig. 1. Adaptive CD compensation in the receiver.

In this chapter, we report the adaptive CD compensation employing adaptive control technique in optical fiber communications. We propose a high-speed and low cost adaptive control algorithm based on the steepest descent method (SDM) for feedback control of the tunable CD compensator. The steepest descent approach has an ability to decrease the iteration number for the convergence. We conducted transmission simulations for the evaluation of the proposed adaptive control technique, and the simulation results show that the proposed technique achieves high-speed compensation of the CD variation caused by the change of the transmission distance in 40 Gb/s transmission.

The organization of this chapter is as follows. In Section 2, we explain the fundamentals of CD and adaptive CD compensation in optical fiber communications for the background knowledge of this research. Then we propose the adaptive control technique based on the SDM for adaptive CD compensation in Section 3. In Section 4, we show the demonstrations and performance analysis of the proposed technique in 40 Gb/s transmission by simulations. Finally, we summarize and conclude this paper in Section 5.

2. Chromatic Dispersion in Optical Fiber Communications

2.1 Fundamental of chromatic dispersion

The group velocity of the light depends on its wavelength when the light is propagating in mediums. This phenomenon is called CD or group velocity dispersion (GVD). In optical communications utilizing the optical fiber as a transmission medium, the optical pulse is affected by the CD as the propagation time depends on the constituent wavelength of the optical pulse as shown in Fig. 2. The CD has two contributions, material dispersion and waveguide dispersion in a single mode fiber (SMF). The material dispersion is attributed to the characteristics of silica that the refractive index changes with the optical wavelength. The waveguide dispersion is caused by the structure of optical fiber, the core radius and the index difference.

Considering optical propagation in the fiber, the propagation constant β is a function of the angular frequency ω and expanded by Taylor expansion as follows.

$$\beta(\omega) = \beta_0 + \beta_1(\omega - \omega_0) + \frac{1}{2}\beta_2(\omega - \omega_0)^2 + \frac{1}{6}\beta_3(\omega - \omega_0)^3 + \dots \quad (1)$$

Here, ω_0 is a center angular frequency, and β_0 , β_1 , β_2 , and β_3 are Taylor's coefficients. The time required for the propagation of unit length τ is obtained by differentiating partially the propagation constant β as follows.

$$\tau(\omega) = \beta_1 + \beta_2(\omega - \omega_0) + \frac{1}{2}\beta_3(\omega - \omega_0)^2 + \dots \quad (2)$$

It is confirmed from (2) that the required time is angular frequency dependent; the propagation time of optical pulse depends on the wavelength in optical communications. The coefficients β_2 and β_3 are first-order and second-order constants indicating the degree of the angular frequency dependence, respectively. Assuming that the second-order CD is negligible, the CD parameter is defined as

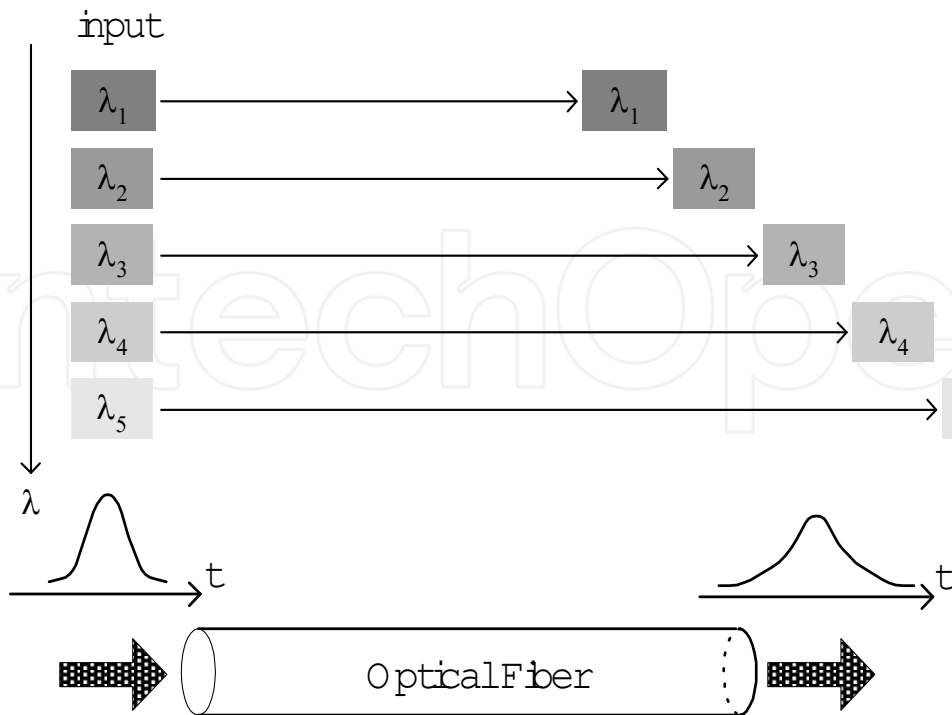

Fig. 2. Schematic diagram of chromatic dispersion.

$$D = \frac{d\tau}{d\lambda} = -\frac{2\pi c}{\lambda^2} \beta_2 \quad (3)$$

where c is the speed of light. The unit of the CD parameter is ps/nm/km.

In SMF, the CD parameter is zero at around 1300 nm and about 20 ps/nm/km at the typical wavelength used for optical communications, around 1550 nm. We have many characteristics of optical fibers such as dispersion shifted fiber (DSF) whose CD parameter is zero at around 1550 nm for the reduction of CD effect in optical fiber communications, and dispersion compensating fibers (DCF) whose CD parameter is minus value for the purpose of static CD compensation.

In optical fiber communications, the optical pulse is affected by the CD as it has relatively wide spectral range corresponding to the bit-rate. Assuming that the optical pulse is a Gaussian waveform for the simplicity, the waveform in time-domain is expressed as

$$U(0, T) = \exp\left(-\frac{T^2}{2T_0^2}\right) \quad (4)$$

where T_0 is a full width at half maximum (FWHM) of the pulse. When the pulse is transmitted for arbitral distance z , the waveform is affected by the CD and distorted as

$$U(z, T) = \frac{T_0}{(T_0^2 - j\beta_2 z)^{1/2}} \exp\left(-\frac{T^2}{2(T_0^2 - j\beta_2 z)}\right) \quad (5)$$

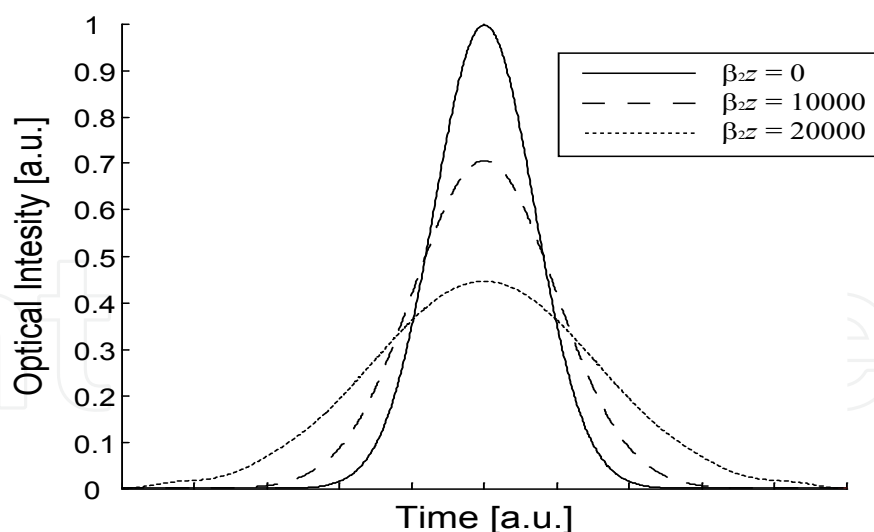

Fig. 3. Optical pulses affected by chromatic dispersion.

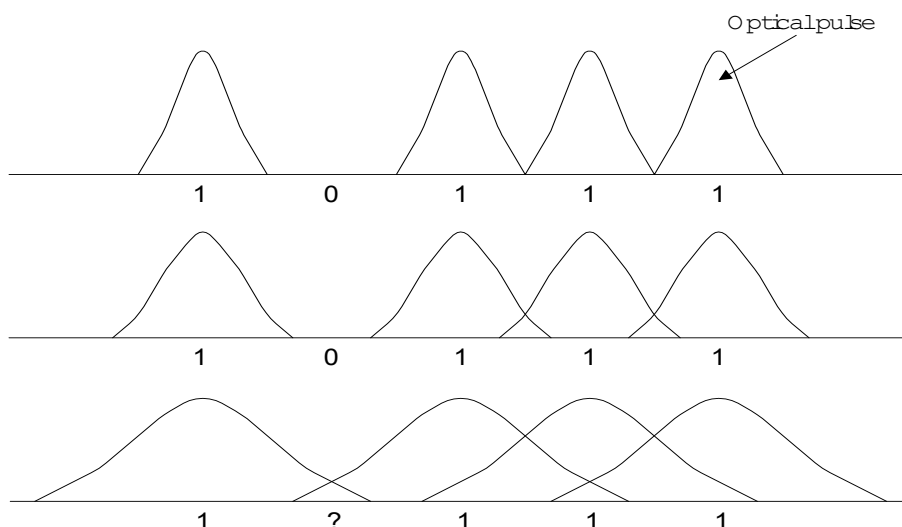

Fig. 4. Interference of neighboring pulses in optical communication.

where we neglect the second-order CD for simplicity as the first-order CD is dominant. Figure 3 shows the waveforms of optical pulse when we change the product of β_2 and z under the condition that $T_0=100$ ps. The larger the product of β_2 and z is, the wider the FWHM of the transmitted waveform is; the effect of CD is larger in the case that the transmission distance is longer and the CD parameter is larger. If the FWHM of the optical pulse gets wider, the possibility of the inter symbol interference (ISI) is higher as shown in Fig. 4. As the ISI causes code error in optical communications, the transmission distance is limited by the CD. Also, the maximum transmission distance is reduced according to the bit rate of the transmission B because the FWHM of the optical pulse T_0 is decreased when the bit rate increases. We can also understand it from the fact that the spectral width is wide in short optical pulse. The effect of CD on the bit rate B can be estimated and the CD tolerance D_T , the limitation of CD that the quality of the transmission is assured, is expressed as

$$|D_T| < \frac{1}{Bz\Delta\lambda} \quad (6)$$

where $\Delta\lambda$ is the range of wavelength in the optical pulse. The CD tolerance is inversely proportional to the bit rate and the transmission distance and the wavelength range of the input pulse.

2.2 Adaptive chromatic dispersion compensation

As mentioned in Section 1, the adaptive CD compensation is an essential technology for high-speed optical fiber communications as the CD tolerance is very small in the systems whose transmission speed is over 40 Gb/s. Many researches have been conducted for the adaptive CD compensation in optical communications. The principle of the CD compensation is very simple as shown in Fig. 5. We can achieve the CD compensation by placing a transmission medium which has the inverse CD value of the transmission fiber in the transmission line. The adaptive CD compensation is achieved by changing the compensating CD value adaptively according to the CD in the transmission fiber. The conventional setup of the adaptive CD compensation is shown in Fig. 1; the tunable CD compensator is feedback controlled with the real-time CD monitoring. In this section, tunable CD compensators and CD monitoring techniques are briefly introduced for the background information of the adaptive control algorithm to be proposed.

We have many types of tunable CD compensators for the adaptive compensation. They are basically implemented by the dispersive medium with the function of tunability, for example, chirped fiber Bragg grating (CFBG) with heater elements (Matsumoto et al., 2001; Eggleton et al., 2000), micro-electro mechanical system (MEMS) (Sano et al., 2003), ring resonator (Takahashi et al., 2006), and so on. We adopt a virtually imaged phased array (VIPA) compensator in the following research. The VIPA compensator is a tunable CD compensator, which is consisted of the combination of a VIPA plate and a three dimensional adjustable surface mirror (Shirasaki, 1997; OOi et al., 2002). The VIPA plate operates as a grating, and the specific spectral components of light is reflected by the mirror to induce CD.

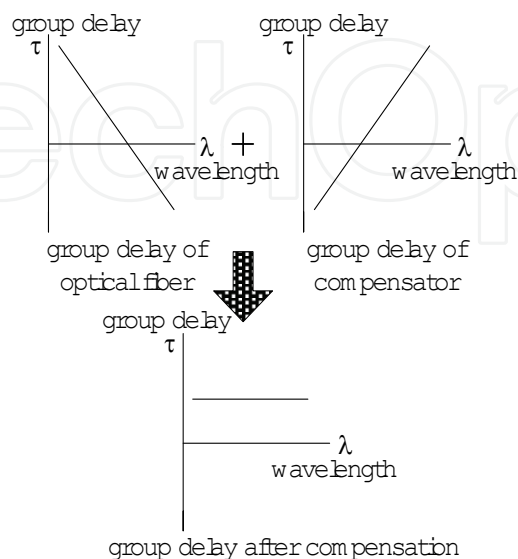

Fig. 5. Principle of chromatic dispersion compensation.

	Response time	Cost	Relationship between transmission quality and monitoring signal	Monitoring range	Pilot signal
Clock power level monitoring method	Good	Good	Fair	Good	Not required
Clock phase detection method	Good	Fair	Good	Poor	Not required
Eye-diagram	Good	Fair	Excellent	Good	Not required
BER	Fair	Poor	Excellent	Good	Required

Table 1. Performances of feedback signals in adaptive CD compensation

We can generate arbitral CD value as the change of the geometry of the three dimensional mirror. In the VIPA compensator, wide compensation range, ± 1800 ps/nm in 10 and 40 Gb/s, is achieved by the appropriate design of the three dimensional mirror.

Also, many kinds of CD monitoring methods are studied and demonstrated for the feedback control of the tunable CD compensators. The typical monitoring signals are bit error rate (BER), eye-diagram, clock power level (Sano et al., 2001), and phase difference of clock signals (Qian et al., 2002). We show the performance comparison of the feedback signals for adaptive control of the tunable CD compensator in Table 1. The requirement of pilot signal is the disadvantage for the BER as the monitoring signal. If we consider each characteristic of the feedback signal, the extracted-clock power level or the eye-diagram is better for the feedback signal in adaptive CD compensation. We adopt the eye-opening value obtained from the eye-diagram as the feedback signal in the adaptive control method to be proposed.

3. High-Speed Adaptive Control Method Based on Steepest Descent Method

In this section, we propose a method of high-speed adaptive control of tunable CD compensator for adaptive CD compensation. We apply the steepest descent method to the adaptive control algorithm in order to reduce the compensation time. The approximation of partial derivative for the steepest descent approach is proposed and applied to the control of the VIPA compensator.

3.1 Steepest descent-based control algorithm for adaptive chromatic dispersion compensation

The adaptive control system must be low cost, high-speed, and applicable to wide dispersion ranges for the adaptive CD compensation in optical communications. Most control systems require high-cost measuring instruments for the CD monitoring. We therefore propose the feedback control method that does not require high-cost CD monitoring. In our proposal, the feedback signal is a received waveform in the time domain. The tunable CD compensator is controlled repeatedly to reshape the waveform. The measurement of the waveform is relatively easy and uninfluential in the transmission

conditions such as pilot-signal requirements. Conventional feedback control is based on the hill-climbing method, which requires a lot of time for optimization. We have therefore applied the steepest descent method to the feedback control for high-speed compensation. Figure 6 shows an optical dynamic routing network with the adaptive CD compensation. Transmitted signals are passed through a route that is chosen arbitrarily among optical paths, being affected by the CD. In the receiver part, the degraded signals are fed into the tunable CD compensator and the dispersion is compensated. The adaptive dispersion compensation is achieved by the combination of a tunable CD compensator and a controller. The compensated signals are received by a photodiode and demodulated.

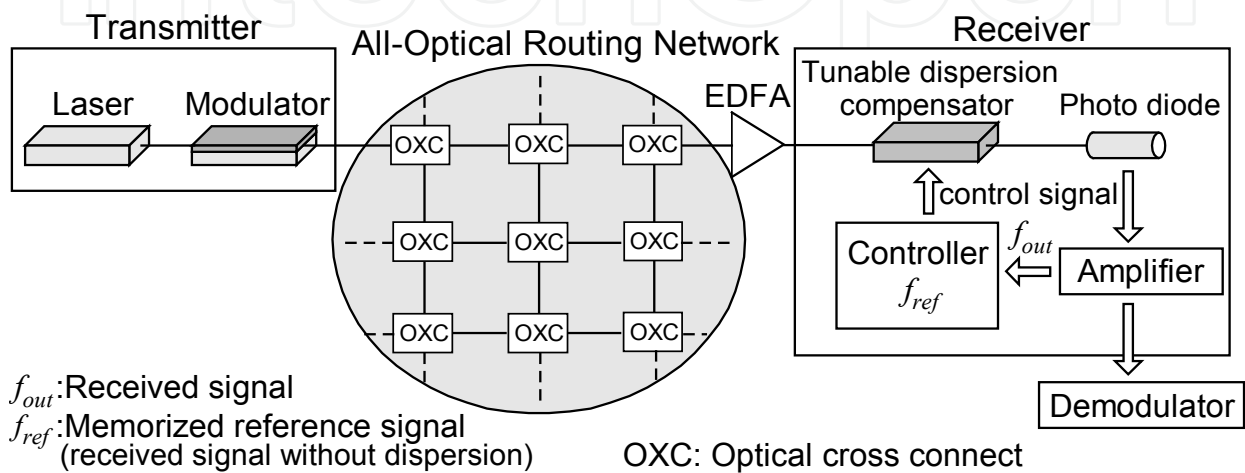

Fig. 6. Schematic diagram of all-optical dynamic routing network with the adaptive dispersion compensation technique.

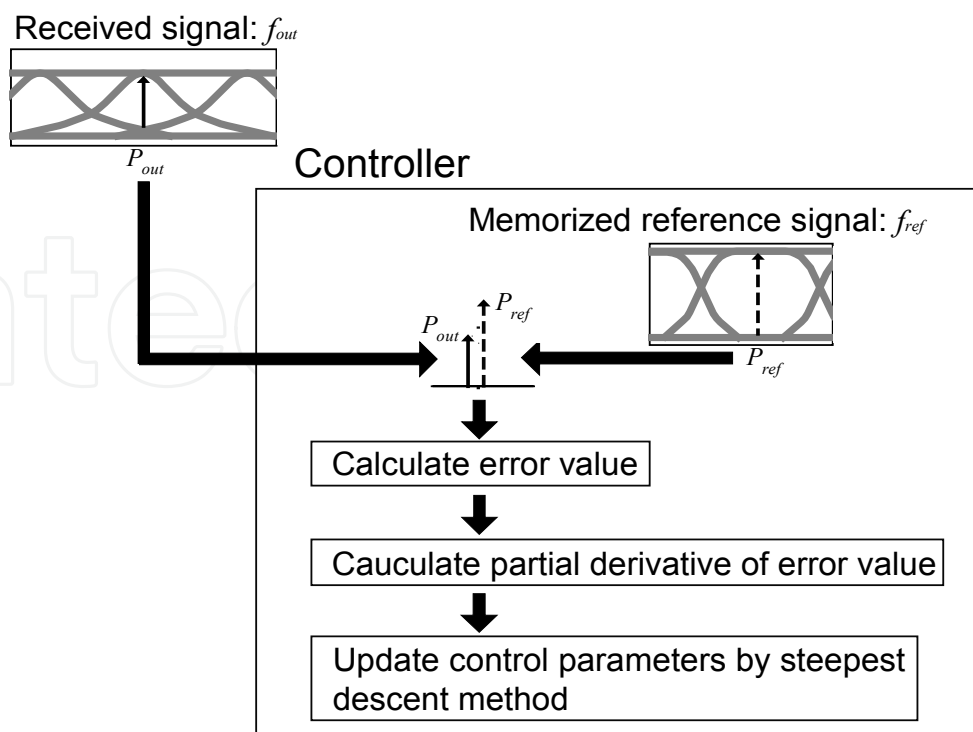

Fig. 7. Procedure of proposed steepest-descent-based control.

The tunable compensator is controlled by our proposed adaptive control method based on the steepest descent method. The proposed procedure of the controller is shown in Fig. 7, where P_{out} and P_{ref} are the eye-opening values (normalized as $P_{ref} = 1$) of the received and reference signals, f_{out} and f_{ref} respectively. In this method, we measure and register the reference signal, f_{ref} which is a received signal unaffected by the CD. The reference signal is determined from the characteristics of the transmitter-receiver set. Therefore, we can copy the reference signal to other receivers after it has been measured once.

The first step is a calculation of an error value: Er . The error value is defined as the difference between the eye-opening values, P_{out} and P_{ref} .

$$Er = \frac{1}{2} (P_{ref} - P_{out})^2 \quad (7)$$

The next step is a calculation of partial derivatives of Er in terms of the control parameters, x_i ($i=1,2,\dots, n$), for the update based on the steepest descent method.

$$\frac{\partial Er}{\partial x_i} = (P_{out} - P_{ref}) \frac{\partial P_{out}}{\partial x_i} \quad (8)$$

We need to measure small changes in P_{out} when x_i changes slightly in order to get the accurate partial derivatives of P_{out} with respect to x_i . However, this is unrealistic as it takes a lot of time for the measurement and our goal is to achieve quick CD compensation. Therefore, we approximate the partial derivatives of P_{out} with respect to x_i . The approximation is to be mentioned at the next subsection.

In the final step, the control parameters are update as

$$x_i \Rightarrow x_i - \varepsilon \frac{\partial Er}{\partial x_i} \quad (9)$$

where ε is an appropriate constant concerning the speed and accuracy of the convergence. We repeat this procedure until the transmission quality becomes optimal. The required number of update iterations is fewer than that of the normal feedback control based on the hill-climbing method due to the steepest descent approach. In practical all-optical dynamic routing networks, the procedure is repeated all the time as the transmission route changes at frequent intervals.

3.2 Approximation of partial derivatives for steepest descent approach

To approximate the partial derivatives of P_{out} with respect to x_i , we need to know the change in one-bit waveforms of the received signal, $w_{out}(t)$, caused by the change in x_i . When we assume that the waveform of the transmitted signal is a Gaussian-like pulse (the peak level is unity) just like in the approximation in return-to-zero transmissions and that the transmission is affected only by the CD, the waveform, $w_{out}(t)$ is calculated analytically in terms of the CD values of the transmission fiber, D_{fiber} ps/nm and TDC, D_{TDC} ps/nm, as

$$w_{out}(t) = v_{peak} \exp\left(-\frac{v_{peak}^2 t^2}{T_{FWHM}^2}\right) \quad (10)$$

$$v_{peak}^2 = \frac{T_{FWHM}^2}{T_{FWHM}^2 + \left(\frac{\lambda^2}{2\pi c} D_{fiber} + \frac{\lambda^2}{2\pi c} D_{TDC}\right)^2} \quad (11)$$

where T_{FWHM} is the FWHM of the transmitted signal, λ is the center wavelength, t is time, and c is the speed of light. The partial derivative of $w_{out}(t)$ with respect to x_i is calculated from (10) and (11).

$$\frac{\partial w_{out}(t)}{\partial x_i} = \pm \frac{v_{peak}^2}{T_{FWHM}^2} \sqrt{1 - v_{peak}^2} \left(\frac{2t^2 v_{peak}^2}{T_{FWHM}^2} - 1\right) \exp\left(-\frac{t^2 v_{peak}^2}{T_{FWHM}^2}\right) \cdot \frac{\lambda^2}{2\pi c} \frac{\partial D_{TDC}}{\partial x_i} \quad (12)$$

Equation (10) shows that the value v_{peak} is the peak level of $w_{out}(t)$. We can measure it in a practical system. Therefore, (12) shows that we can obtain the approximated partial derivative of $w_{out}(t)$ with respect to x_i because T_{FWHM} and λ are known parameters. We obtain the partial derivative of the peak value in $w_{out}(t)$ by substituting 0 for t .

$$\left. \frac{\partial w_{out}(t)}{\partial x_i} \right|_{t=0} = \frac{\partial v_{peak}}{\partial x_i} = \pm \frac{v_{peak}^2}{T_{FWHM}^2} \sqrt{1 - v_{peak}^2} \cdot \frac{\lambda^2}{2\pi c} \frac{\partial D_{TDC}}{\partial x_i} \quad (13)$$

The value of v_{peak} corresponds to the eye-opening value in nonreturn-to-zero (NRZ) transmission approximately. Therefore, the partial derivative of P_{out} with respect to x_i is approximated as follows.

$$\frac{\partial P_{out}}{\partial x_i} = \pm \frac{P_{out}^2}{T_{FWHM}^2} \sqrt{1 - P_{out}^2} \cdot \frac{\lambda^2}{2\pi c} \frac{\partial D_{TDC}}{\partial x_i} \quad (14)$$

3.3 Detailed control algorithm for VIPA compensator

In the simulations described in the next section, we employ a VIPA compensator as the tunable CD compensator. The VIPA compensator has a single control parameter, i.e. CD S ps/nm. The detailed control procedure of the VIPA compensator is as follows. In general, we can apply the proposed method to any kind of tunable CD compensators.

- (i) Initialize the parameter of the VIPA compensator: S ps/nm

$$S = 0 \text{ ps/nm} \quad (15)$$

- (ii) Calculate the error value: Er

The error value, E_r , is derived from (7).

If P_{out} is zero, we go to (iii), otherwise to (iv).

(iii) Update S by the hill-climbing method

$$S \Rightarrow S - \Delta S \tag{16}$$

where ΔS ps/nm is an appropriate small constant. We then go on to (v).

(iv) Update S by the steepest descent method

We calculate the partial derivative of E_r from (8) and (14).

The partial derivative of P_{out} with respect to S is approximated as

$$\frac{\partial P_{out}}{\partial S} = \pm \frac{P_{out}^2}{T_{FWHM}^2} \sqrt{1 - P_{out}^2} \cdot \frac{\lambda^2}{2\pi c} \tag{17}$$

The parameter S is updated as

$$S \Rightarrow S - \varepsilon \frac{\partial E_r}{\partial S} \tag{18}$$

where ε is an appropriate constant. We then go to (v).

(v) Judge the error value: E_r

We calculate E_r again by using (7). If E_r increases or becomes small enough, the procedure stops. Otherwise, we go back to (ii) and repeat the same process. However, in practical all-optical dynamic routing networks, the compensation process is repeated all the time as the dispersion value changes frequently.

4. Transmission Simulations at 40 Gb/s

4.1 Simulation results in NRZ-OOK transmission at 40 Gb/s

Numerical transmission simulations using OptiSystem were conducted to verify the application of the proposed technique to 40 Gb/s optical fiber transmission system. In the proposed control method, we have to set the constants for search, ε and ΔS , appropriately. They were adjusted for the 40 Gb/s transmission and set at 3×10^5 and 30, respectively. The output power of a distributed feedback laser diode (DFB-LD) at the transmitter was 0 dBm. We supposed that the modulation format were NRZ-OOK. The central wavelength of the transmitted signal was 1550 nm. The transmission path was a non-zero dispersion shifted fiber (NZ-DSF). We assumed that CD, polarization mode dispersion (PMD), self-phase modulation (SPM), and other nonlinearity affect the transmitted signal. The power loss was amplified to 0 dBm by an erbium-doped fiber amplifier (EDFA) after both of the fiber transmission and the dispersion compensation by the VIPA compensator. The EDFA, the

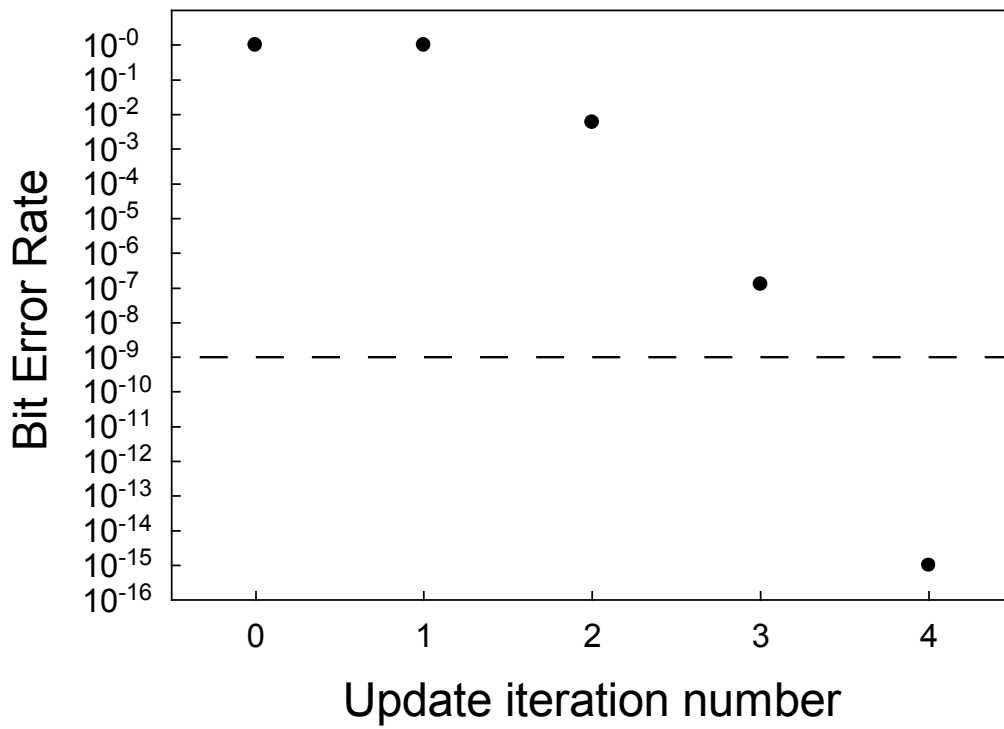

(a)

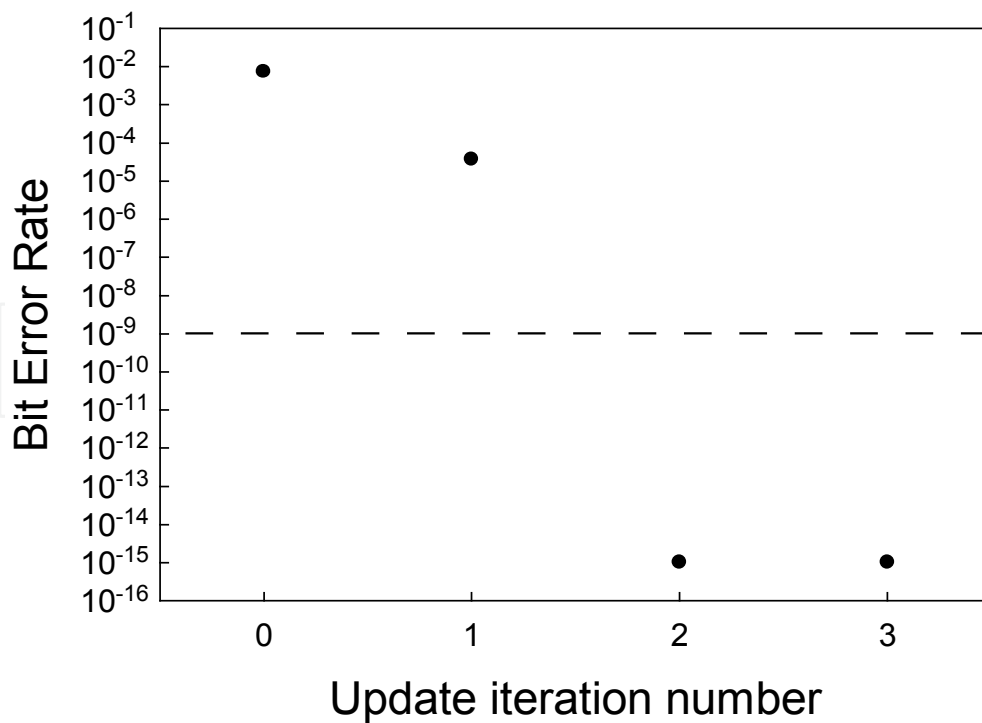

(b)

Fig. 8. BERs at every update of the compensator (a) 0→20km, (b) 20→25km.

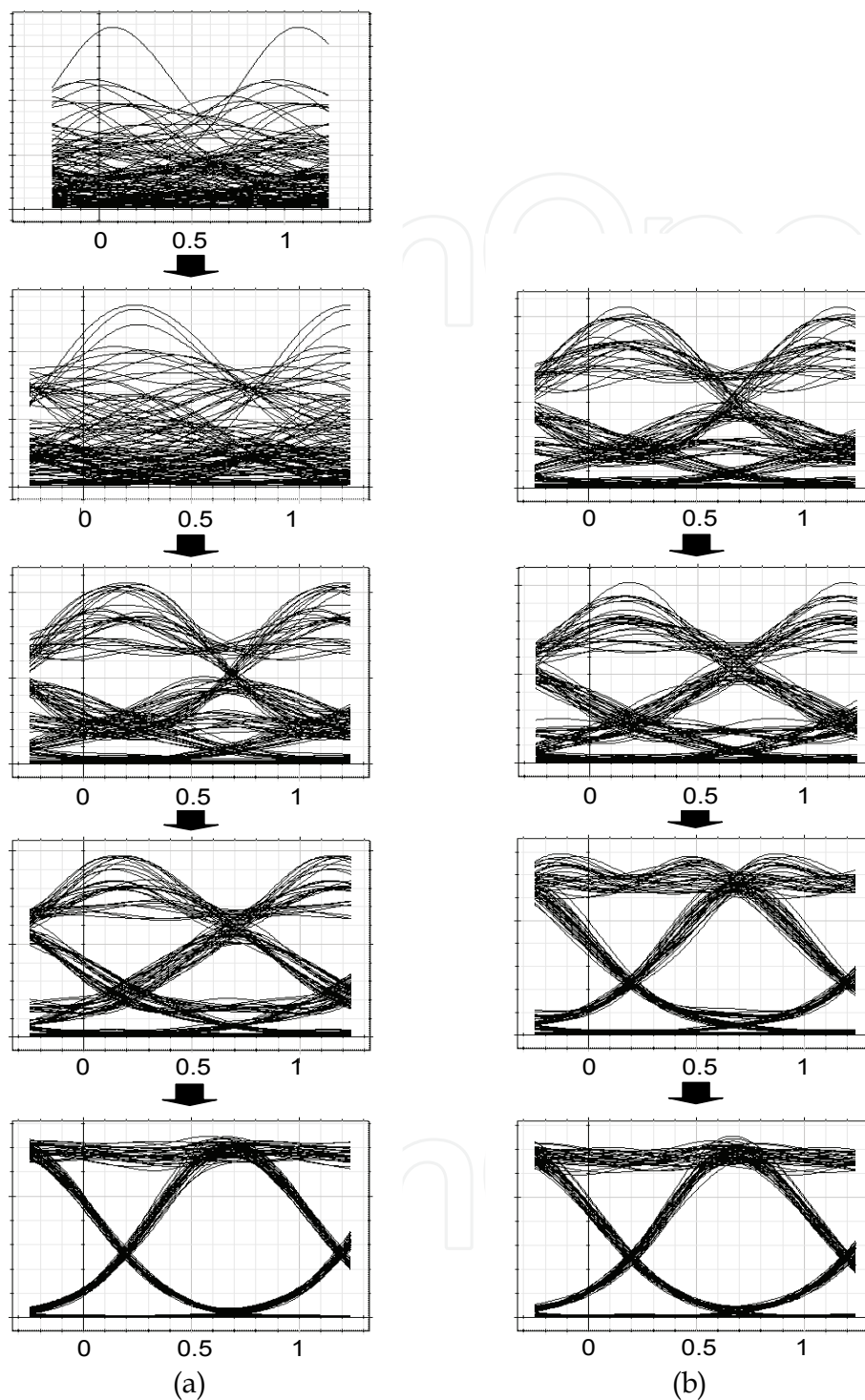

Fig. 9. Eye-diagrams at every update of the compensator (a) 0→20km, (b) 20→25km.

receiver, and other optical components were assumed to have moderate levels of noise. Transmission simulation results are shown in Fig. 8 and Fig. 9. In these simulations, the initial value of S was set at 0. Fig. 8 shows the BERs at every update of the VIPA compensator when the transmission distance changes (a) from 0 to 20 km (dispersion: 0 →

100 ps/nm) and (b) from 20 to 25 km (dispersion: 100 \rightarrow 125 ps/nm). The compensation improved the BER (a) from 1.0×10^0 to 1.0×10^{-15} and (b) from 7.41×10^{-3} to 1.0×10^{-15} , respectively. As shown in Fig. 9, the eye-diagrams measured by a sampling oscilloscope were found reshaped. These results show that the CD compensation with the proposed control method improve the transmission quality.

The update iteration number to achieve a sufficiently low BER ($<10^{-9}$) were four and two, respectively in these two cases. A single calculation of the next dispersion value requires less than 10 ms. The response time of the VIPA compensator is 2 ms for every 1 ps/nm compensation. Therefore, the time required for ± 400 ps/nm CD compensation is about 1 s, which is determined practically by the response time of the VIPA compensator. This technique achieves a high-speed adaptive control of a tunable CD compensator in 40 Gb/s transmission since the update iteration number is small and the calculation time with the proposed approximation is short enough. The proposed technique is more effective if the response time of the tunable CD compensator is faster as the required iteration number is decreased by our proposed adaptive control technique based on the steepest descent method.

4.2 Compensation range and required iteration number

Figure 10 shows the compensation range of the proposed method at 40 Gb/s. We measured BERs before and after compensation when the CD value changed from 0 ps/nm to arbitrary value. The compensation range in which the BER after compensation is less than 10^{-9} is about from -450 to 450 ps/nm, corresponding to a NZ-DSF path-length change of about ± 90 km. This range is wide enough for compensating the change of CD caused by dynamic routing. In this wide compensation range, the iteration number required for error free transmission ($\text{BER} < 10^{-9}$) is less than 15. The fast adaptive CD compensation is also achieved by the proposed adaptive control technique as the required iteration number is small.

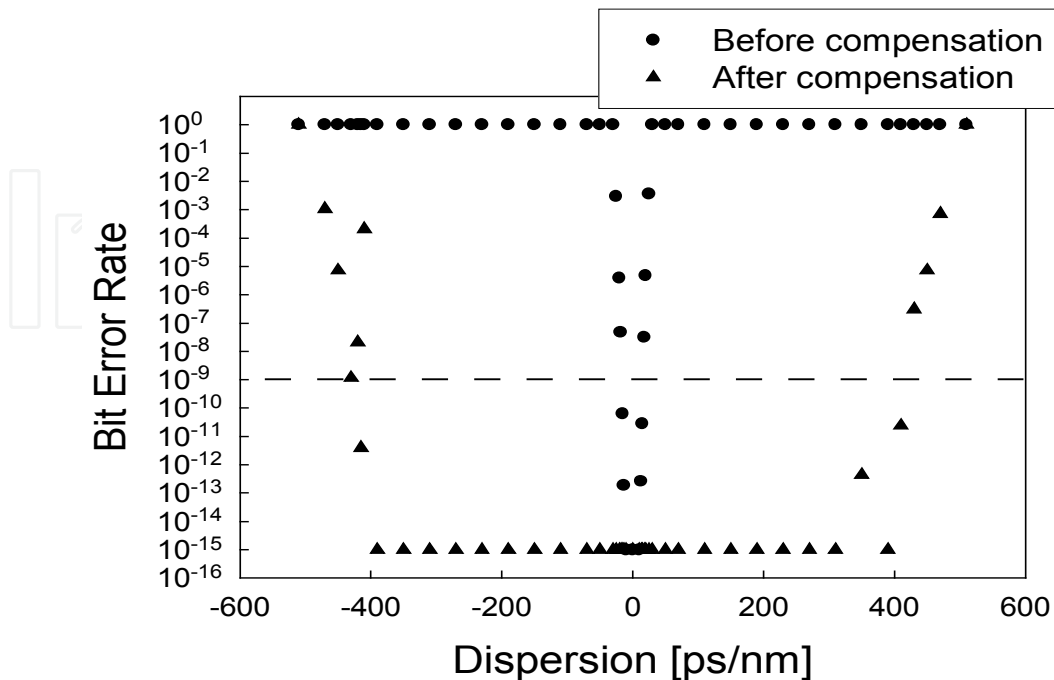

Fig. 10. Compensation range of the proposed method at 40 Gb/s.

5. Conclusion

In this chapter, we have proposed high-speed adaptive CD compensation with the adaptive control method based on the steepest descent method and reported the performances evaluated by numerical simulations.

The simulation results show that the proposed control method based on the steepest descent method controls the tunable CD compensator quickly and effectively for a wide dispersion range in 40 Gb/s transmission. The range is up to ± 450 ps/nm, and the required compensation time is about 1 s for the CD variation within ± 400 ps/nm at 40 Gb/s. These achievements are valuable for the future optical networks employing dynamic routing technique.

6. References

- Agrawal, G. (2002). *Fiber-Optic Communication Systems*, Wiley-Interscience, ISBN 0-471-21571-6, USA
- Eggleton, B. J.; Ahuja, A.; Westbrook, P. S.; Rogers, J. A.; Kuo, P.; Nielsen, T. N. & Mikkelsen, B. (2000). Integrated Tunable Fiber Gratings for Dispersion Management in High-Bit Rate Systems. *IEEE/OSA Journal of Lightwave Technology*, Vol. 18, No. 10, (Oct. 2000) pp. 1418-1432
- Katz, G.; Sadot, D. & Tabrikian, J. (2006). Electrical Dispersion Compensation Equalizers in Optical Direct- and Coherent-Detection Systems. *IEEE Transactions on Communications*, Vol. 54, No. 11, (Nov. 2006) pp. 2045-2050
- Matsumoto, S.; Ohira, T.; Takabayashi, M.; Yoshiara, K. & Sugihara, T. (2001). Tunable Dispersion Equalizer with a Divided Thin-Film Heater for 40-Gb/s RZ Transmission. *IEEE Photonics Technology Letters*, Vol. 13, (Aug. 2001) pp. 827-829
- Ooi, H.; Nakamura, K.; Akiyama, Y.; Takahara, T.; Terahara, T.; Kawahata, Y.; Isono, H. & Ishikawa, G. (2002). 40-Gb/s WDM Transmission With Virtually Imaged Phased Array (VIPA) Variable Dispersion Compensators. *IEEE/OSA Journal of Lightwave Technology*, Vol. 20, (Dec. 2002) pp. 2196-2203
- Sano, T.; Iwashima, T.; Katayama, M.; Kanie, T.; Harumoto, M.; Shigehara, M.; Suganuma, H.; & Nishimura, M. (2003). Novel Multichannel Tunable Chromatic Dispersion Compensator Based on MEMS and Diffraction Grating. *IEEE Photonics Technology Letters*, Vol. 15, No. 8, (Aug. 2003) pp. 1109-1111
- Shirasaki, M. (1997). Chromatic-Dispersion Compensator Using Virtually Imaged Phased Array. *IEEE Photonics Technology Letters*, Vol. 9, No. 12, (Dec. 1997) pp. 1598-1600
- Tanizawa, K. & Hirose, A. (2007). Adaptive Control of Tunable Dispersion Compensator That Minimizes Time-Domain Waveform Error by Steepest Descent Method. *IEEE Photonics Technology Letters*, Vol. 18, No. 13, (Jul. 2006) pp. 1466-1468
- Tanizawa, K. & Hirose, A. (2007). Performance Analysis of Steepest-Descent-Based Feedback Control of Tunable Dispersion Compensator for Adaptive Dispersion Compensation in All-Optical Dynamic Routing Networks. *IEEE/OSA Journal of Lightwave Technology*, Vol. 24, No. 4, (Apr. 2007) pp. 1086-1094
- Yagi, M.; Satomi, S.; Tanaka, S.; Ryu, S.; & Asano, S. (2005). Field Trial of Automatic Chromatic Dispersion Compensation for 40-Gb/s-Based Wavelength Path

Protection. *IEEE Photonics Technology Letters*, Vol. 17, No. 1, (Jan. 2005) pp. 229-231

IntechOpen

IntechOpen



Adaptive Control

Edited by Kwanho You

ISBN 978-953-7619-47-3

Hard cover, 372 pages

Publisher InTech

Published online 01, January, 2009

Published in print edition January, 2009

Adaptive control has been a remarkable field for industrial and academic research since 1950s. Since more and more adaptive algorithms are applied in various control applications, it is becoming very important for practical implementation. As it can be confirmed from the increasing number of conferences and journals on adaptive control topics, it is certain that the adaptive control is a significant guidance for technology development. The authors the chapters in this book are professionals in their areas and their recent research results are presented in this book which will also provide new ideas for improved performance of various control application problems.

How to reference

In order to correctly reference this scholarly work, feel free to copy and paste the following:

Ken Tanizawa and Akira Hirose (2009). High-Speed Adaptive Control Technique Based on Steepest Descent Method for Adaptive Chromatic Dispersion Compensation in Optical Communications, Adaptive Control, Kwanho You (Ed.), ISBN: 978-953-7619-47-3, InTech, Available from:

[http://www.intechopen.com/books/adaptive_control/high-](http://www.intechopen.com/books/adaptive_control/high-speed_adaptive_control_technique_based_on_steepest_descent_method_for_adaptive_chromatic_disp)

[speed_adaptive_control_technique_based_on_steepest_descent_method_for_adaptive_chromatic_disp](http://www.intechopen.com/books/adaptive_control/high-speed_adaptive_control_technique_based_on_steepest_descent_method_for_adaptive_chromatic_disp)

INTECH

open science | open minds

InTech Europe

University Campus STeP Ri

Slavka Krautzeka 83/A

51000 Rijeka, Croatia

Phone: +385 (51) 770 447

Fax: +385 (51) 686 166

www.intechopen.com

InTech China

Unit 405, Office Block, Hotel Equatorial Shanghai

No.65, Yan An Road (West), Shanghai, 200040, China

中国上海市延安西路65号上海国际贵都大饭店办公楼405单元

Phone: +86-21-62489820

Fax: +86-21-62489821

© 2009 The Author(s). Licensee IntechOpen. This chapter is distributed under the terms of the [Creative Commons Attribution-NonCommercial-ShareAlike-3.0 License](#), which permits use, distribution and reproduction for non-commercial purposes, provided the original is properly cited and derivative works building on this content are distributed under the same license.

IntechOpen

IntechOpen