

We are IntechOpen, the world's leading publisher of Open Access books Built by scientists, for scientists

4,800

Open access books available

122,000

International authors and editors

135M

Downloads

Our authors are among the

154

Countries delivered to

TOP 1%

most cited scientists

12.2%

Contributors from top 500 universities



WEB OF SCIENCE™

Selection of our books indexed in the Book Citation Index
in Web of Science™ Core Collection (BKCI)

Interested in publishing with us?
Contact book.department@intechopen.com

Numbers displayed above are based on latest data collected.

For more information visit www.intechopen.com



Robotic Excavation

Ahmad Hemami
McGill University
Canada

1. Introduction

In this chapter robotic excavation or automated excavation is discussed. Excavation as performed by an excavator is the process of moving bulk material by digging, cutting and scooping, or a combination of them. The term robotic excavation implies the application of state of the art in robot motion control for automating excavating machinery, so that such a machine can accomplish excavation tasks by itself and without the continuous supervision and intervention of an operator. This type of application is still in its state of infancy and much more remains to be developed yet.

1.1 Introduction

Excavation in general term is the process of removing soil, ore or any bulk material from its original place, by digging out or digging away, and loading it (say, onto a vehicle for hauling). In this sense, it covers a variety of methods that may or may not include all the different functions of loosening (or cutting) the material, digging it and finally loading it. Also, the equipment used for this purpose are different, based on the geometry and physical properties of the environment they excavate, and the way the three basic functions (loosening, digging and loading) are executed (sequentially or combined together). There are two types of machines, in general, rotary and cyclic. The work here is intended for automation of cyclic excavating machines.

Automation of excavation process becomes required in a number of applications. For instance, in mining for more productivity, safety of workers and more efficiency an automated system is desirable; in remote places like moon an automated excavating device is required to get samples. Hazardous contaminated soil removing and mining radioactive materials are other examples.

Attention must be paid to the difference between an excavation operation and an excavation process. The latter is the function performed by an excavator. Thus, excavation process comprises a combination of cutting, digging and scooping. Automation of the process, in fact, implies the automation of the machine that performs the task. For automation, an analysis of the process and what is involved in it is necessary.

It is very important to note that the physical properties of the material to be excavated have a direct effect on the excavation method and the properties and design of the equipment. In fact they significantly determine the forces required on the cutting tool, and hence the power requirement of the machine. For simplicity of expression, hereafter, the material to be excavated will be referred to as "bulk media" or "soil". Also, instead of excavation automaton, the term "robotic excavation" is often interchangeably used.

1.2 Chapter contents

A general but brief review of the various excavation processes and the sort of machines in use is given in section 2. This will indicate the broad scope of the scenarios on excavation and its automation. The emphasis of the chapter is to make a distinction between what is involved in an excavation operation and the process of excavation, itself. In section 3 the question of automating the excavation operation is investigated. An example illustrates all the various tasks to be automated in an excavation operation by a particular class of an excavating machine. In this work, we narrow down our concern only to the issues relevant directly to automating an excavation process. Section 4 covers the analysis of the forces involved in an excavation process. These force components vary during the excavation and depend on the machine used. These are the forces that the cutting tool of an excavator must overcome. Knowledge about the force of excavation is quite important to automation of the task. Section 5 covers the analysis of robotic excavation and the necessary steps to be followed for robotic modelling of an excavating machine. The discussion is enhanced by some detailed analysis of a front-end loader and its counter part in underground mining (Hemami, 1992). This example is used for all the other discussions throughout the chapter. Section 6 is devoted to modelling of a front-end-loader type excavator as a robot manipulator. Section 7 considers the nature of what happens in an excavation process and how it can be modelled. The criteria to be used for automating such a process are also discussed. Section 8 elaborates on the conclusion of what must be carried out towards a workable automated machine.

2. Excavation methods and equipment

2.1 General excavation methods

Although not a sharp distinction line could, in general, be drawn between the various types of excavation, but because of dependency of the scope of operation on the factors such as: the quantity of the soil to be moved, the location of the excavation site, the relative width, breadth and depth, the type of soil and the purpose of excavation, excavation falls into the following basic types:

1. bulk-pit excavation
2. bulk wide area excavation
3. loose bulk excavation
4. limited-area vertical excavation
5. trench excavation
6. tunnel excavation
7. dredging

Bulk-pit excavation is excavation of considerable depth as well as considerable volume. The equipment must work against the face of nearly vertical walls from inside the pit, and the soil must be hauled away.

Bulk wide-area excavation is like the bulk-pit excavation, but shallower in depth and larger in area, and the site is accessible from many directions. The excavated soil is hauled a shorter distance.

Loose bulk excavation is like excavation of canals where the soil is not hauled away but cast into a new position. Moreover, the operation is usually performed from the surrounding ground rather than from inside the pit.

Limited-area vertical excavation is where the soil must, out of necessity, be lifted out vertically; the method is used for loose and wet soil, and the banks must be supported by shoring or sheathing.

Trench excavation sometimes falls into the category of the limited- area vertical excavation; generally, the width and depth of operation are limited.

Tunnel excavation is completely underground; the width and depth (or height) are limited. (Tunnel excavation can be divided into underground excavation and tunnelling.

Dredging is the removal of soil from underwater.

In mining, particularly considering the various equipments, excavation may be categorized as:

- Open-pit excavation (in surface mining)
- Underground excavation
- Tunnelling
- Underwater excavation

In **open-pit excavation** the various types of excavation methods, as mentioned in numbers 1 to 5 above, are used. For **underground operations**, because of space and other limitations, the type of the equipment that can be used are quite different from size, capacity and manoeuvrability points of view, as will be discussed later. Special tunnelling machines are employed in general **tunnelling** operations (which are usually different from ore mining operations). The environmental conditions for **underwater excavations** are quite different from others, as the name implies; however, depending on each particular case some of the equipment for other types of excavation might be utilized for excavating under the water, or other special equipment would be necessary. Tunnelling and underwater equipment are not discussed further in more detail in this study.

2.2 Excavating machines

In this section an overview of the various equipments that are currently in use by mining and construction industries are presented, without getting into their detailed description.. These equipments can be first categorized into **surface mining** or **open-pit mining excavating** equipment, and **underground mining** excavating equipment. Further in each category, they can be divided into **non-continuous (or Cyclic)** and **continuous** machines.

2.2.1 Open-pit mining (surface mining) cyclic machines

Five different types of cyclical excavating machines can be identified; these are:

- Power Shovel
- Dragline
- Scraper
- Clamshell
- Backhoe (hoe)

Figure 1 shows the schematics of these machines illustrating the basic difference between their structures. The **power shovel** is the most efficient of the various machines for excavating and loading large quantities of soil. The **dragline** is the unit of excavating equipment most ideally suited to handle loose bulk excavation. It operates most efficiently from an elevation higher than the soil being dug, thus very suitable for original surface; it is seldom used for excavating at or above its travel level.

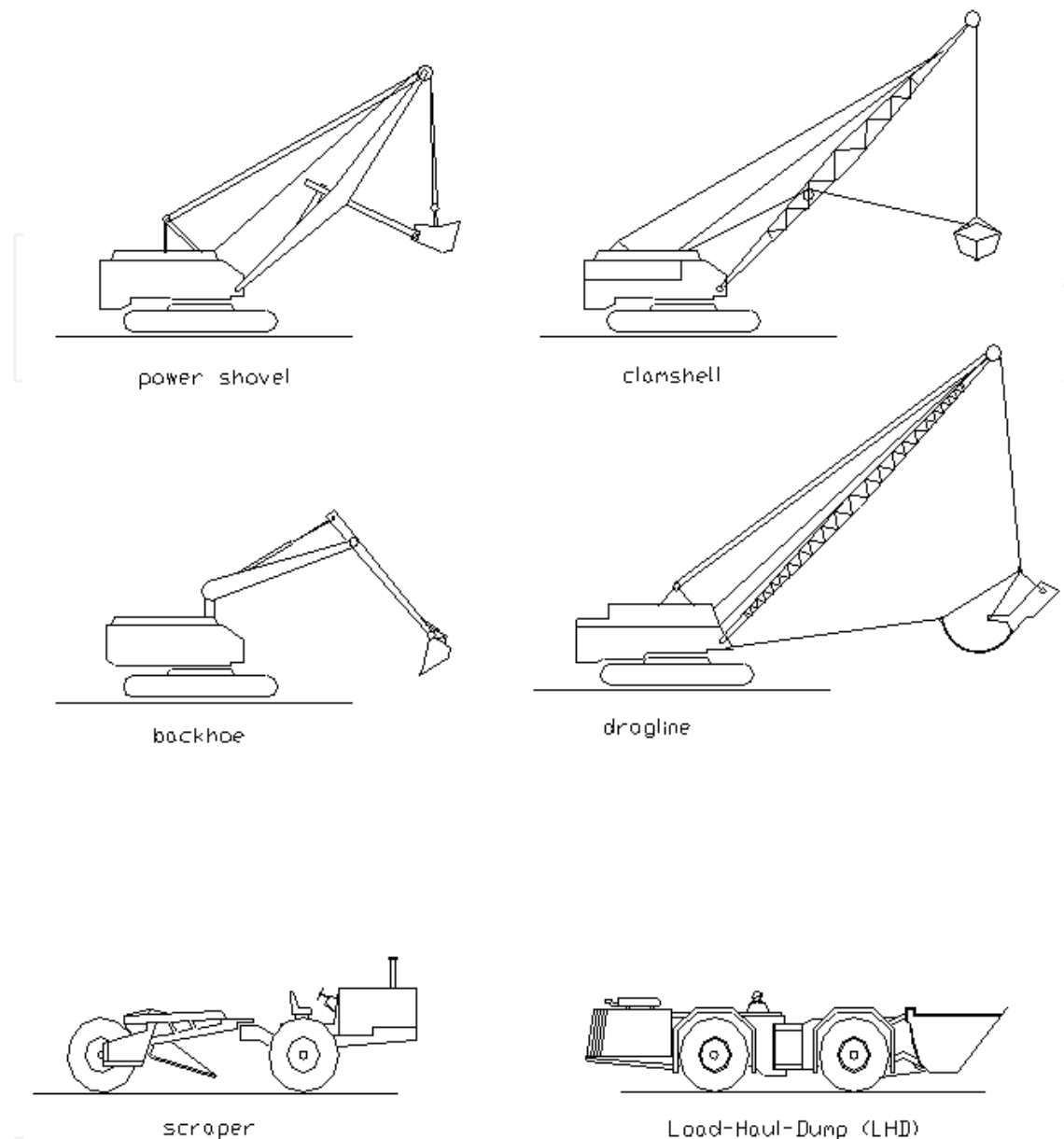

Fig. 1. More frequently used excavating machines

Unlike the power shovel none of its power is available for direct pressure on the soil. The bucket is filled by pulling it toward the dragline after being penetrated into the soil only by the force of its weight. The dragline performs many kinds of loose bulk excavation well; it has an extensive use in overburden stripping and surface mining. Draglines are mounted on crawlers which enable them to work on tight areas.

The **scraper** is designed for loading a thin layer of soil over a large area. It has the advantage of being able to haul and unload the soil to the desired destination. Thus it is very appropriate for bulk wide-area excavation. This machine is mostly pushed or/and pulled by tractors mounted on rubber tires; the cutting edge of the bowl (its bucket) penetrates 4-6 in. into the soil, depending on the density of the soil formation. Difficulty is encountered in loading loose dry sand and rock and, also, in unloading wet, sticky soil. Their greatest use is found in unconsolidated soil that requires little or no loosening; but they are finding increasing applications in loading and hauling in open-pit mining.

The **clamshell** is most suitable for limited-area vertical excavation, like foundation excavations; for this reason, most generally it is used as a secondary unit to muck out in the rear of the more productive machines. For various jobs that call for removal of the soil from below the level where the machine rests, or require moving the soil above the machine, in particular where the soil being dug is loose, soft or wet, the clamshell is ideal. The clamshell consists of a bucket hung from the boom of a crane that can be either crawler or wheel mounted. The two halves of the bucket are dropped onto the soil to be excavated; then the bucket is closed, encompassing soil between the two halves.

The **backhoe** is customarily a secondary tool in surface mining. Contrary to the shovel and dragline where the general concern is the volume excavation, the backhoe is convenient for scraping off and cleaning adhering overlay soil from surface, and also for trenching and digging ditches.

2.2.2 Underground mining cyclic machines

The choice of equipment employed for underground mining primarily is enforced by the properties of the ore to be excavated. The physical size of the ore and its geometry, that determine the method of mining, and the cost are secondary parameters. For instance, continuous mining machines can be used for soft and semi hard soil, but do not have much success with hard rock that must be fragmented by blasting (or alternative method) before excavation.

The machines for underground mining are much smaller in size and the capacity in comparison with the equipment for open-pit mining. Two most used underground mine cyclic excavators are:

- Overshoot loader
- Load-Haul-Dump (LHD) unit

Overshoot Loader is a device which picks up the blasted soil from the front and without turning discharges it to the rear in a truck to do the haulage, or to a conveyor. It may be powered by compressed air, electricity or diesel engine. The mounting can be crawlers, wheels or it is bound to move on rails. The operator stands by the side of the machine, or he can operate from a few meters away by a remote system, if equipped. Overshoot loaders are usually small in size to be able to work in small drifts.

In larger mines a **Loader** (front-end loader) can be used to excavate and transfer the soil to a **mining truck** (dump-truck). A loader is extensively used in construction and road work, and to a less extent in surface mining; in the same way it can be used for loading the ore. However, the size of loader, and the space it requires for operation make it less desirable for underground, unless for the wide and high stopes, where the high mobility and rapid loading overweighs the shortcoming.

A **Load-Haul-Dump** machine, or simply **LHD**, as the name implies (Figure 2), can combine the work of a loader and a dump-truck. In this way, one operator works instead of two in the former case. LHD's are specially designed for working in mines; their physical structure, and size thus enable them to operate and move without difficulty in narrower areas and with smaller height. Moreover, they are made in two parts hinged together in order to facilitate their turning through curves (Figure 3). LHD's are mounted on rubber tires which give them more mobility, and they are widely used in underground mining work. Some LHD loaders are equipped with two buckets; in this way their transportation capacity is increased.

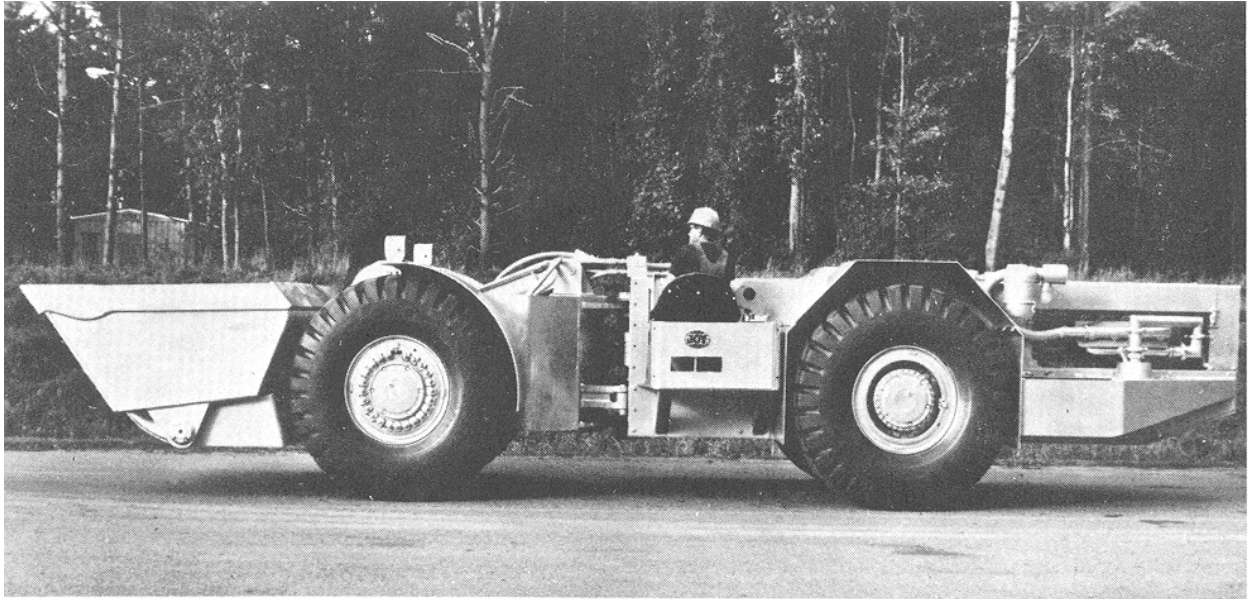

Fig. 2. A Load-Haul-Dump unit

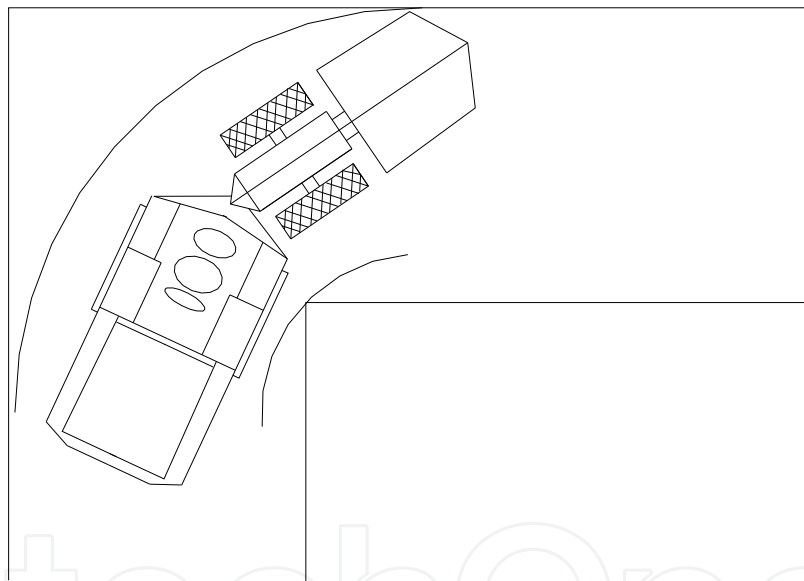

Fig. 3. LHD is designed to negotiate curves better

3. Automation of excavating operation

3.1 Autonomous excavation

In reality what is expected from automation, when it will become possible, is autonomous excavation. In fact auto-loading, which is the whole focus of this chapter, is only a necessary part of a bigger scenario of being able to perform the tasks of an operator by an automated excavation machine. When the outcome of research on excavation automation leads to technical capability for successful auto-loading, this capability must be integrated with other automated tasks, in order to be utilized. Such a scenario is shown in figure 4. In this sense, for an automated loading operation the same sort of actions that an operator does must be automatically performed. This requires the following three processes and integrating them:

- a. Automation of the loading function
- b. Automation of navigation
- c. Automation of obstacle detection and avoidance, for movement of both vehicle and bucket during dumping

A preliminary analysis shows that in order to carry out the above tasks an operator uses his power and intelligence for the following:

1. Determining in what part of muck pile to start loading,
2. Lowering the bucket and running the vehicle forward,
3. Determining the starting point of loading action,
4. Executing the motion for the bucket,
5. Sensing whether motion is taking place in normal way,
6. Sensing if the vehicle advances or tires are slipping,
7. Deciding the final loading point,
8. Moving back and lowering the bucket for haulage,
9. Monitoring the performance of the vehicle,
10. Selecting the delivery point,
11. Deciding on the route to the delivery point,
12. Navigating to that point while watching for avoiding ground obstacles on the way,
13. Raising the bucket while watching for hitting nothing at the delivery point,
14. Dumping the loaded media.

The above list shows that there are various decision making and actions to be executed. All of these must be performed without fault for successful automation.

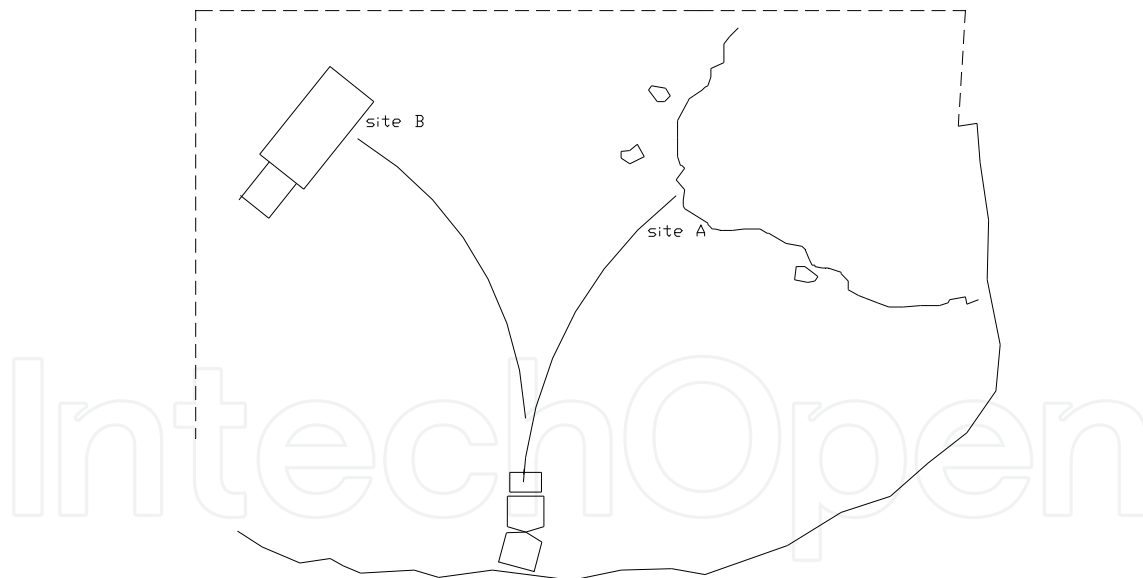

Fig. 4. Various tasks in an excavation scenario

3.2 Auto-loading

Auto-loading concerns only the items 4 to 8 on the list of the subtasks in section 3.1. Considering, again, in more detail, what an operator does in terms of loading function (this depends on the experience and judgement of an operator, so the exact details change from person to person), he drives the lowered bucket to the muck pile, then starts raising and simultaneously tilting the bucket, until it is almost clear from the pile. In this moment the

bucket is supposed to be filled, thus the operator pulls back while lowering the bucket, for haulage. Any part of this cycle will be corrected, repeated and/or adjusted if the result is other than expected. Knowing this is what needs to be performed automatically, the following primary steps summarize what can be done to lead to the required results:

- an appropriate trajectory be defined for the bucket,
- the bucket is driven such that it follows the trajectory,
- the operation is watched to be carried out properly.

Performing the above requires that:

- the essential force is provided and adjusted when necessary,
- this provided force must be used for loading the bucket, rather than wasteful pushing,
- the bucket is getting filled in the process of following the trajectory,
- the machine parts are not damaged.

The rest of this chapter is devoted to the auto-loading only. For this, furthermore, we consider automation of LHD only. As, was said before, an LHD and front loader are similar, for this purpose. Most of the results, nevertheless, are general and applicable to all excavating machines. We are seeking the way the loading function of an LHD can be automated. That is, a machine can load itself without the interference of an operator.

4. Excavation force analysis

In the process of loading, a bucket is subject to resisting forces and torques which, in order for the bucket motion to continue, they must essentially be overcome. Also, the necessary force for moving the bulk of the loaded rock must be supplied by the active forces moving the bucket. There are four resisting forces, denoted by r_1 through r_4 in figure 5, at each instant, which must be overcome. In addition to counteracting these forces, the actuating mechanism must provide r_5 corresponding to the inertia force for motion of the load (not shown). The addressed forces are:

- r_1 : weight of the loaded soil and that of above the bucket.
- r_2 : force of compacting the soil by bucket.
- r_3 : friction forces between bucket and the soil.
- r_4 : digging resistance of the soil.
- r_5 : the necessary force to move the soil in and above the bucket.

The forces to be exerted by the loader bucket at this moment are in the opposite direction of those shown.

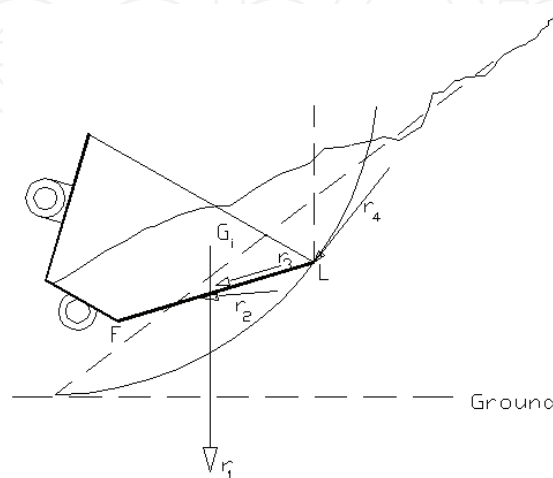

Fig. 5. Medium force components on a bucket

The above defined force elements depend on a number of factors, such as the type of soil, its properties, and the shape and material of the bucket. They have a stochastic nature and can vary considerably from point to point in the mass of a heap of bulk medium. The factors affecting their magnitude can be seen to be of four categories:

1. The tool (Bucket): The shape, size, geometry and material of the cutting device (Also, teeth on the cutting edge)
2. Environment: Temperature, gravity, terrain slope.
3. Excavator: The excavation process, itself, is not unique in various machines
4. Medium: The soil property variation is quite enormous, dictated by :
 - type of soil (its mechanical properties, like hardness and cohesion)
 - uniformity (mixture of various soils)
 - water content
 - temperature
 - particle size
 - compactness
 - adhesion (Also a function of tool material)

Certain references given at the end of this chapter indicate some previous work to formulate the forces encountered by a cutting tool. Because of the great number of the factors (Up to 32 have been reported, some of them less important, but at least 20 of them are quite important), it is quite difficult, if not impossible, to determine the force values based on given properties. Only approximate values of the force can be expected from any formulation.

5. Process analysis

The question of how to automate the operation of a loader, backhoe, Load-Haul-Dump unit, and so on leads to the fact that because motion control is involved, a robot control scheme can be employed. For this reason, the term robotic excavation is often used when referring to excavation automation. In the case of a front-end loader, LHD and power shovel, auto-loading is an analogous term. With regards to the control of industrial robots a good deal of knowledge and technology has been developed for their control. As mentioned before, in what follows all the analysis is performed for a typical LHD, which represents all the excavators of the same category.

There are two major differences between a robotic arm and an LHD (or similar excavating machine). The first difference is the relatively large tool and payload in the case of an excavator compared to usually small tool and payload for a robot manipulator. The tool for an excavator is its cutting element or bucket. This implies a significantly large interaction between the tool and its environment. The second difference is that the base of a robot manipulator is fixed, whereas for an LHD there is no fixed base. As a result of this, the final results can be different from expected, as it is depicted in figure 6, which illustrates a deformation of the vehicle structure leading to a change in the trajectory.

Control of a robot arm is based on the definition of a trajectory and then motion control to lead the tool through the defined trajectory. Based on the similarity to a robot arm, there are then two primary steps: modelling the excavator as a robot arm and defining a trajectory for the bucket to follow. Since a bucket is a rigid body defining a trajectory for it implies defining a trajectory for three of its points. If for simplification we assume the motion of the bucket during scooping to be a planar motion, then the trajectories of two points in the

plane of motion are sufficient to describe the plane trajectory of the bucket. One appropriate choice for motion study is the cutting edge, because it includes the points of action of the cutting forces. Selection of a proper trajectory must be based on a sound analysis rather than repeating the same kind of trajectory as practiced by an operator. Obviously, for any given task the trajectory definition depends on a number of parameters corresponding to the bucket size and the medium to be loaded. Figure 7 illustrates some typical bucket tip trajectories for the same excavator and the same bucket, for example. AN_2 is for a heavier material compared to AN_1 (point L in the figure represents the cutting edge of the bucket; see section 6). It is necessary to point out, however, that in the process of following the trajectory is not the crucial criterion; the main objective is to fill the bucket, preferably with minimum energy.

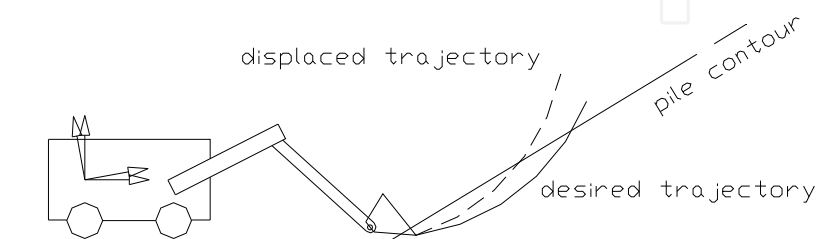

Fig. 6. Deformation of excavator changes the trajectory

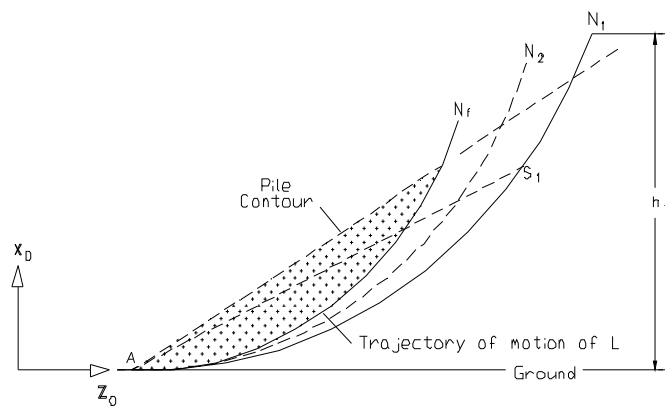

Fig. 7. Trajectories can be defined base on medium property (density, for instance)

In scooping there are a number of forces involved, as discussed before; if the active force on the bucket at each instant while it moves along a trajectory does not accord with the resistive forces, then some undesirable outcome, like an empty bucket or wasteful effort of pushing the vehicle with tires slipping instead of advancing, will result. In any of these cases the action must be stopped. That is to say, if not enough material is loaded in the bucket, the motion must not be continued; also, if a situation like that shown in figure 8 is encountered or the bucket has reached a dead stop, increasing the active force is not the right thing to do, since it is equivalent to wasting energy. This does not mean that in order to properly control the scooping operation one must have the knowledge about the exact magnitudes of the involved forces at each instant (in fact, this force has a stochastic nature, so it is impossible to define its certain magnitude). But, it implies that the force requirement must continuously be monitored, so that none of the two undesirable cases happens.

Monitoring the resistive forces is contrary to considering them as a disturbance to the problem of position control for trajectory following, which one could think of as an alternate approach. The latter is the way an industrial robot is controlled to follow a path. This is because, as pointed out earlier, the primary goal is to fill the bucket, not to just follow a trajectory (possibly with a half filled bucket). In this sense, it becomes essential to determine the approximate variation of the resultant resisting force on the bucket along the trajectory. For the sake of clarity two possible variation patterns are shown in figure 9. These are fictitious patterns, but show that at any point along the trajectory what the maximum and minimum expected values for resistive force are. Any time that the measured force is outside of the range it indicates that either the bucket is not filled enough or it has hit a sizable restriction.

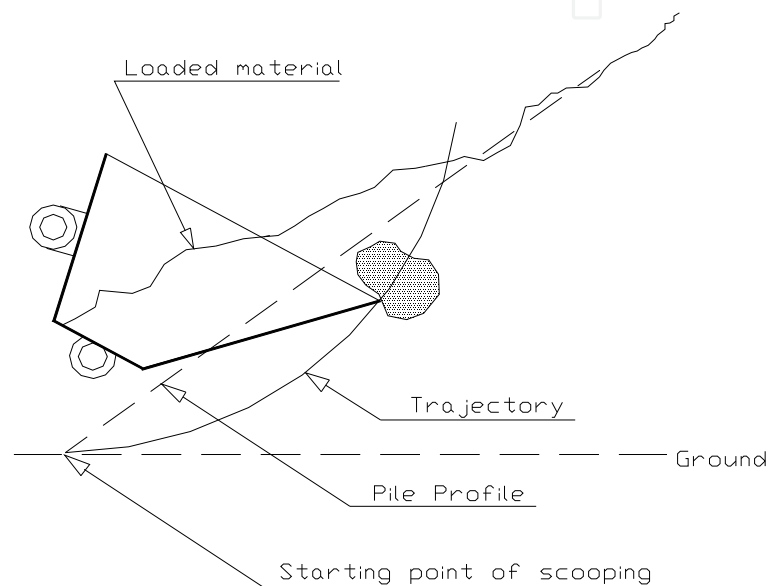

Fig. 8. A possible scenario in practice

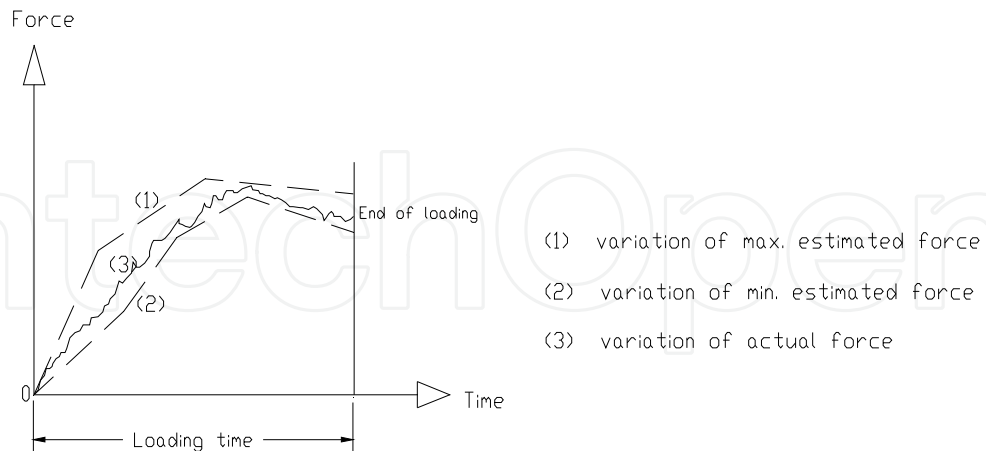

Fig. 9. A range of magnitudes can be found for the resistive forces along the trajectory

6. Kinematic modelling

In this section kinematic modelling of an LHD as a robot manipulator is carried out. A similar approach can be employed for other excavating machines (Ostoja-Starzewski and

Skibinievski, 1989, Vaehae et al, 1991), with the incorporation of more details for additional segments such as the mechanism for manipulating a backhoe bucket (Hemami, 1995). The latter can be slightly different from one manufacturer to other, but the general approach is the same. Section 6.1 describes the kinematic model and definitions, and section 6.2 presents the forward and inverse kinematic solutions for the model. Finally the relationship between the actuators efforts and resistive force at the bucket are expressed by the formulation of Jacobians for the robotic model in section 6.3

6.1 Kinematic model

An LHD consists of a driving unit to which the loading gear is attached through a pivot connection; the reason for pivoting is to make it possible for the longer vehicles to negotiate curves in narrower underground passages. Figure 10 shows the schematic of the loading gear model of a typical LHD-unit. This mechanism can be assumed to consist of a platform to which two sets of linear actuators are attached. The platform is free to move forward (and backward) with respect to the ground (this is symbolically indicated by the rollers in figure 10). There are three distinct actuations in the scooping function of this machine: a push forward by the driving vehicle, a pushing/pulling action of usually two parallel cylinders CE, raising and lowering the supporting arm BEH, and pushing/pulling action by cylinder AD. Observation of a loading action (also in dumping) reveals that the motion of the bucket provided by the three forces involved, the push of the vehicle and the forces of the hydraulic cylinders, can be assumed to be a plane motion. This makes the analysis much simpler. In this sense, the cutting edge of bucket is represented by a point L. The coordinate system $x_4y_4z_4$ is attached to the bucket at this point. The three loading forces provided by the actuators give rise to two force components along x_4 and y_4 and a torque about z_4 , at this edge of the bucket. Figure 10 shows also the definition of various dimensions in the mechanism.

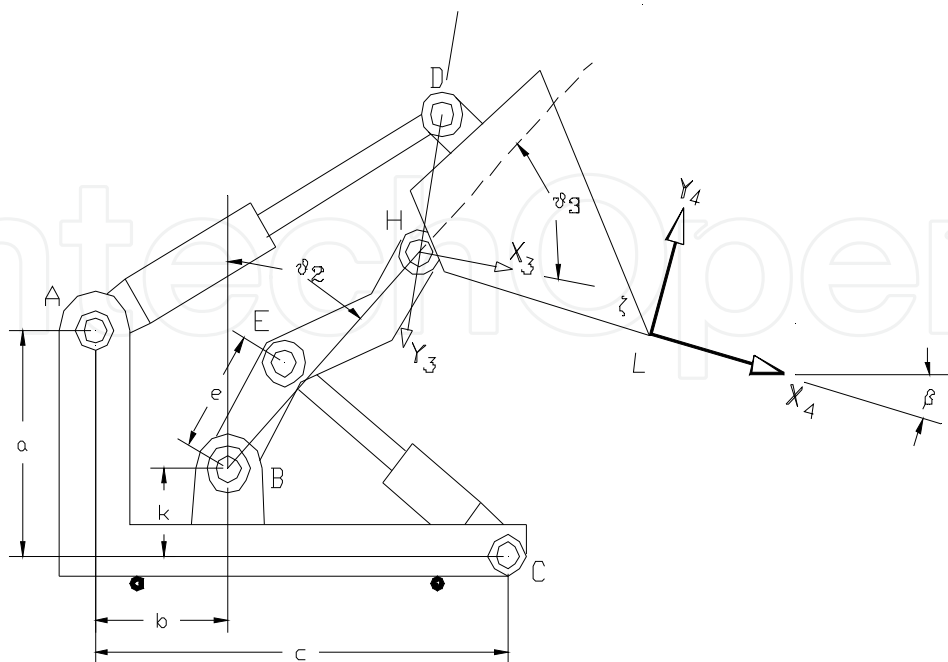

Fig. 10. Model of the loading gear in a loader or LHD

The function of the cylinder CE is to rotate the supporting link BEH about point B; and the function of cylinder AD is to give a rotation to the bucket about point H. Taking into account the fact that the direction of the forward force from the vehicle is almost unchanged during loading, it can be seen that the bucket is manipulated by one force and two torques. It can, thus, be regarded as being actuated by a prismatic joint followed by two revolute joints. Thus, the loading mechanism is modelled as a robotic arm with three degrees of freedom. Point L is taken as the tool point. Figure 11 shows the coordinate system chosen for the three joints based on (Denavit and Hartenberg, 1955) and according to (Lee, 1982).

The frame $x_0y_0z_0$ is attached to the vehicle at any arbitrary point. It serves as the reference coordinate system at any instant before a loading action is started. It serves also to define the direction of the force and movement of the prismatic actuator, both along the z_0 axis. $x_1y_1z_1$ is attached to joint 2 at point B, its direction is such that θ_2 , the second joint variable, has a positive sign when clockwise, as shown. Similarly $x_2y_2z_2$ is attached to joint 3 at point H and it has the same sense of direction as joint 2. Finally the bucket attached coordinates $x_3y_3z_3$ is chosen such that the axis y_3 passes through point D (which is a distinct point on the bucket), and θ_3 is also positive clockwise. This choice of coordinate system slightly simplifies the analysis. $x_4y_4z_4$ coordinate system, which will be used to define the forces on the bucket at the tool point, however, has a different sense of direction. Table 1 shows the associated parameters for the three actuators.

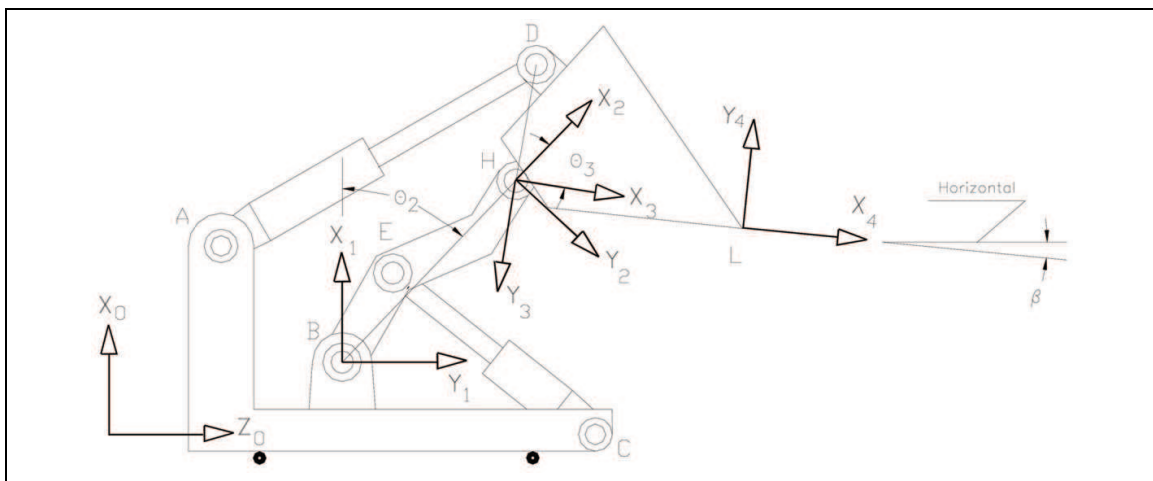

Fig. 11. Definition of coordinate systems

JOINT	α	a	d	θ	TYPE
1	90°	k	var.	0	prismatic
2	0	r	0	var.	revolute
3	0	0	0	var.	revolute

Table 1. Definition of Denavit-Hartenberg parameters

The relationship between the two coordinate systems $x_3y_3z_3$ and $x_4y_4z_4$ is constant and is defined by the transformation matrix:

$$A_4 = \begin{bmatrix} \cos\psi & \sin\psi & 0 & q_1 \\ \sin\psi & -\cos\psi & 0 & q_2 \\ 0 & 0 & -1 & 0 \\ 0 & 0 & 0 & 1 \end{bmatrix} \tag{1}$$

where constants q_1, q_2 are the coordinates of point L in frame 3 and ψ is the angle between x_3 and x_4 (see figure 10). q_1, q_2 and ψ depend on the bucket and the attachment dimensions. The transformation matrices between frame 0 to frame 3 are accordingly given by

$$A_1 = \begin{bmatrix} 1 & 0 & 0 & k \\ 0 & 0 & -1 & 0 \\ 0 & 1 & 0 & b+d_1 \\ 0 & 0 & 0 & 1 \end{bmatrix} \quad (2)$$

$$A_2 = \begin{bmatrix} C_2 & -S_2 & 0 & rC_2 \\ S_2 & C_2 & 0 & rS_2 \\ 0 & 0 & 1 & 0 \\ 0 & 0 & 0 & 1 \end{bmatrix} \quad (3)$$

and

$$A_3 = \begin{bmatrix} C_3 & -S_3 & 0 & 0 \\ S_3 & C_3 & 0 & 0 \\ 0 & 0 & 1 & 0 \\ 0 & 0 & 0 & 1 \end{bmatrix} \quad (4)$$

In equations (3) and (4), C_i and S_i stand for $\cos \theta_i$ and $\sin \theta_i$, respectively. Note that for better clarity, in equation (2) the constant b (See figure 10) is separately added to the offset of joint 1; this is because $x_0y_0z_0$ is shown outside the moving platform.

6.2 Kinematic solutions

In the operation of the loader, we are concerned about the position of point L and the bucket orientation with respect to ground. The position of the loading point L is how high and how much in front of its starting position point L has moved (or must move) at any instant during scooping motion. These two values are the magnitudes of x_0 and z_0 , respectively. As a measure of the bucket angle, a convenient choice is the angle β between z_0 and x_4 , thus when x_4 is parallel to ground this angle is zero. The position and orientation of the bucket (position of point L and the orientation of the front side) is determined from the transformation matrix:

$$T = A_1 A_2 A_3 A_4 = \begin{bmatrix} \cos(\theta_2 + \theta_3 + \psi) & \sin(\theta_2 + \theta_3 + \psi) & 0 & q_1 \cos(\theta_2 + \theta_3) - q_2 \sin(\theta_2 + \theta_3) + r \cos \theta_2 + k \\ 0 & 0 & 1 & 0 \\ \sin(\theta_2 + \theta_3 + \psi) & -\cos(\theta_2 + \theta_3 + \psi) & 0 & q_1 \sin(\theta_2 + \theta_3) + q_2 \cos(\theta_2 + \theta_3) + r \sin \theta_2 + b + d_1 \\ 0 & 0 & 0 & 1 \end{bmatrix} \quad (5)$$

Thus, the upward position of point L, as a function of θ_2 and θ_3 is defined by the first element of the 4th column of matrix T, and the forward displacement is given by the third element of the same column. Also, angle β can be seen to be given by:

$$\beta = \frac{\pi}{2} - (\theta_1 + \theta_2 + \psi) \quad (6)$$

The values of the joint angles θ_2 and θ_3 can be directly measured by means of encoders attached to the joints at B and H. The forward displacement (d_1), when necessary, can also

be determined from the forward motion of the vehicle by using an appropriate sensor and simple calculations.

The inverse kinematic problem for this three degree of freedom manipulator is quite straightforward. If at any instant of time three values are given for β , bucket orientation, h , the height, and l , the forward distance, then equation (5) and (6) can be used to determine d_1 , θ_2 and θ_3 as follows. From the given value of β and equation (6) the sum of $\theta_2 + \theta_3$ can be immediately found. From the calculated value for $\theta_2 + \theta_3$ and the value for h , two values for θ_2 can be obtained; the difference between the two is a \pm sign which results from using a cos function. However, more likely the negative answer is rejected because of the physical range of admissible values. Finally the value for d_1 may be determined from the result of previous calculation of θ_2 and θ_3 and the given value for l .

6.3 Jacobian relationships (relating active and resistive forces)

Jacobian matrices of the mechanism can be used for both velocity relationships and force relationships. That is, defining the bucket velocities (Two translations and a rotation, for planar motion) in terms of the actuator velocities, and the forces at the cutting edge of the bucket (two forces and one torque, associated with planar motion) in terms of actuator efforts. For the force vector at the bucket cutting edge, it is convenient to assume that the bucket is momentarily stationary. This assumption is not unreasonable because of the slow motion of the bucket. Because there are only three degrees of freedom which give a plane motion to this manipulator, only a 3x3 reduced Jacobian matrix is sufficient. Moreover, because weight is always a significant part of the load, then the Jacobian matrix of the tool point with reference to the world coordinates $x_0y_0z_0$ is more appropriate. This matrix is analytically determined in equation (8). The relationship between the force/torque vector in the joints coordinates and that of the load in the reference coordinates is

$$\tau = J^T F \tag{7}$$

where with the choice of J as defined above, that is $J = J^L_0$,

$$J^L_0 = \begin{bmatrix} 0 & -(q_1 S_{23} + q_2 C_{23} + r S_2) & -(q_1 S_{23} + q_2 C_{23}) \\ 0 & -1 & -1 \\ 1 & (q_1 C_{23} - q_2 S_{23} + r C_2) & q_1 C_{23} - q_2 S_{23} \end{bmatrix} \tag{8}$$

$$F = \begin{bmatrix} \text{vertical component of force at } L \\ \text{horizontal component of force at } L \\ \text{torque at } L \end{bmatrix} \tag{9}$$

$$\tau = \begin{bmatrix} \text{Pushing (pulling) force of vehicle} \\ \text{Torque at joint B} \\ \text{Torque at joint H} \end{bmatrix} = \begin{bmatrix} f_1 \\ \tau_2 \\ \tau_3 \end{bmatrix} \tag{10}$$

and T represents transposition.

It is, however, necessary to find the relationships between f_2 , the force in the hydraulic cylinder CE, and τ_2 and between f_3 , the force of cylinder AD and τ_3 . These relationships are functions of θ_2 and θ_3 and can be found from geometric dimensions and angle relationships. Thus:

$$\tau_2 = -ef_2 \sin(\pi - \alpha - \gamma - \varepsilon) = -ef_2 \sin(\alpha + \gamma + \varepsilon) \quad (11)$$

where α is the angle of cylinder CE with the base, γ is that of the link BE with its vertical support and $\varepsilon = \text{angle EBH} = \text{constant}$, all shown in figure 10. But

$$\alpha + \theta_2 = \frac{\pi}{2} \quad (12)$$

and the angles α and γ are related according to

$$\tan \gamma = \frac{k + e \sin(\alpha + \varepsilon)}{c - b - e \cos(\alpha + \varepsilon)} \quad (13)$$

In view of the equations (11), (12) and (13), therefore:

$$\tau_2 = -ef_2 \sin\left(\frac{\pi}{2} - \theta_2 + \varepsilon + \gamma\right) = -ef_2 \cos\left(\theta_2 - \varepsilon - \tan^{-1} \frac{k + e \cos(\theta_2 - \varepsilon)}{c - b - e \sin(\theta_2 - \varepsilon)}\right) \quad (14)$$

Moreover, it can be seen that

$$\tau_3 = gf_3 \sin \eta \quad (15)$$

where $g = \text{HD} = \text{constant}$ and $\eta = \text{Angle HDA}$. Angle HDA is more conveniently, and without ambiguity, calculated from the dot product of vectors AD and HD. In this respect, the relative coordinates of points A, H and D (regardless of d_1) are determined as

$$A: \begin{bmatrix} a \\ 0 \\ 0 \end{bmatrix}$$

$$H: \begin{bmatrix} rC_2 + k \\ 0 \\ rS_2 + b \end{bmatrix} \quad \begin{array}{l} H \text{ is the origin of frame } x_2y_2z_2, \\ \text{thus fourth column of } A_1A_2 \end{array}$$

and

$$D: A_1A_2A_3 \begin{bmatrix} 0 \\ -g \\ 0 \\ 1 \end{bmatrix} \rightarrow \begin{bmatrix} rC_2 + k + gS_{23} \\ 0 \\ rS_2 + b - gC_{23} \end{bmatrix}$$

which lead to:

$$\overline{AD} = \begin{bmatrix} rC_2 + gS_{23} + k - a \\ 0 \\ rS_2 - gC_{23} + b \end{bmatrix} \tag{16}$$

and

$$\overline{HD} = \begin{bmatrix} gS_{23} \\ 0 \\ -gC_{23} \end{bmatrix} \tag{17}$$

It follows from equations (16) and (17), after simplification, that:

$$\eta = \cos^{-1} \frac{r S_3 + (k - a) S_{23} - b C_{23} + g}{\sqrt{b^2 + g^2 + r^2 + (k - a)^2 + 2gr S_3 + 2(k - a)(r C_2 + g S_{23}) + 2b(r S_2 - g C_{23})}} \tag{18}$$

Since η cannot become negative there is no sign ambiguity in the determination of η from equation (18). If $\cos \eta$ is called w then in light of equations (15) and (18)

$$\tau_3 = g f_3 \sqrt{1 - w^2} \tag{19}$$

that is, computation of the angle η , itself, is not necessary.

Equations (7), (14) and (19) can be used to find the three forces f_1 , f_2 and f_3 that are required to give rise to a force F at the tip of the bucket. Conversely, they can be measured to monitor the resisting force/torque at the cutting edge of the bucket.

7. Motion analysis and control

A robotics approach to formulate the problem of auto-loading required the preliminary steps of modelling and analysis, as discussed in the previous sections. In this section the real control problem is touched and discussed. From a control viewpoint this question is raised: For the control of the excavation process (auto-loading) what must be measured and what must be controlled?

7.1 Motion analysis

Considering the operation of an LHD loader by an operator, initially he lowers the bucket until its front edge touches the ground; that is, a zero orientation of bucket with the terrain. He forwards the vehicle towards the pile of soil/fragmented rock, and continues until certain resistive force is sensed. He then operates the hydraulic cylinders to simultaneously tilt and raise the bucket. The entire motion is made around these actions, repeated only once or more, based on each operator's personal experience and specific method. This approach to control the motion of bucket, that is, mimicking the operator's actions to move the bucket,

has been practically implemented (Steel, et al, 1991), later blended with some induced vibration. Without the induced vibration the operation has not been successful. This mimicking the operator's action, however, is not necessarily the best way to load the bucket in terms of the energy used, or its effect on the tires and the other machine components.

A systematic approach suggests that a trajectory with minimum energy be defined for the bucket to follow. Studies for this minimum energy trajectory have given some results (Hemami, 1993). Other studies for an appropriate trajectory can be found in (Sarata et al, 2003, 2005). As mentioned earlier (see figure 6) a fundamental problem that arises is that the defined trajectory is relative to a fixed world coordinates, whereas due to deformation of the loading mechanism the trajectory can be easily displaced or distorted from its original form. For this reason some of the works done on the subject suggest using a camera to monitor the loading action, based on the load inside the bucket (Sing, 1991, Stentz et al, 1999). In reality, this approach does not define how to adjust the motion, particularly if a situation as depicted in figure 8 arises, where the camera is not able to detect).

7.2 Motion control

Various motion control schemes have been suggested. The application has been particularly for a backhoe operation in digging a trench (Seward, et al, 1988, 1992). This is based on the assumption that the machine works always with the maximum power and that the trajectory is a straight line (the bucket moves horizontally to cut a layer in the trench). The actuation power must provide the required forces to maintain the desired velocity. To achieve this, a velocity control scheme may be implemented, while the variation in the resisting forces is regarded as a disturbance to the motion. A fuzzy logic formulation has followed (Shi et al, 1995, 1996).

In a small scale, the excavation process is like when we take sugar with spoon from a pot. If at each instance the power behind the spoon is superior to the resistance faced by the spoon (and the spoon is usually strong enough not to break), the spoon will be filled. One exception is when a big chunk exists, for which we either put it inside or outside the spoon (that is the challenge for an automated system). A review of the reaction of a medium to a cutting force reveals that the medium-tool interface can be modelled as shown in figure 12. This figure shows the situation for a one dimensional tool. In a loader or excavator, this is the case for each actuator. F_A is the actuator force and F_R is the resistive force of the medium. The tool is represented by a mass-spring-damper, which transfers the active force and can deform based on the magnitude of the resistive force. The medium is also modelled as a mass-spring-damper, though the mass and damping are relatively much larger than those of the tool, whereas the stiffness is much smaller. Although this model suggests a linear behaviour, but the process itself is not linear in the sense that if the active force is higher than the resistive force, then there is a motion; otherwise, no motion takes place.

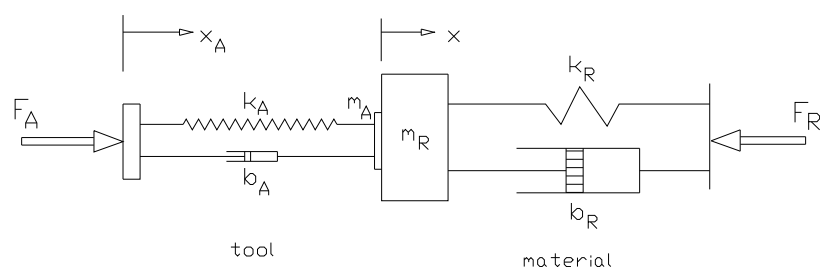

Fig. 12. modelling the interaction of too and medium

7.2 Control strategy

Figure 12 helps in comprehending what happens in a real situation in case of an excavating machine. In an excavator this can happen for each of the actuators, that, if the actuator effort is larger than the effect of the medium resistance, then there will be acceleration, or an already started motion will continue. Otherwise, the motion in that actuator stops and a deformation follows. It also helps to understand the validity of a control strategy, suggesting that a two-level control scheme is necessary (Bullock et al, 1990, Hemami, 1995). At one level motion control is performed based on a feedback from the measurement of actuator positions and velocities. This is a secondary level and the sampling of the variables must be performed at a higher frequency. A primary level control is performed with a lower frequency, which in fact is a corrective monitoring of the defined trajectory. This primary level control is based on a force feedback. That is, sampled at a lower rate the forces at the actuators are measured. If any of these forces is outside of its defined approximate range, then a correction to the trajectory is carried out and the previous trajectory is replaced by a revised one. The “defined approximate range” is based on all the information and the necessary calculations as discussed in section 4 and 6 of this chapter. Figure 13 helps to show this philosophy.

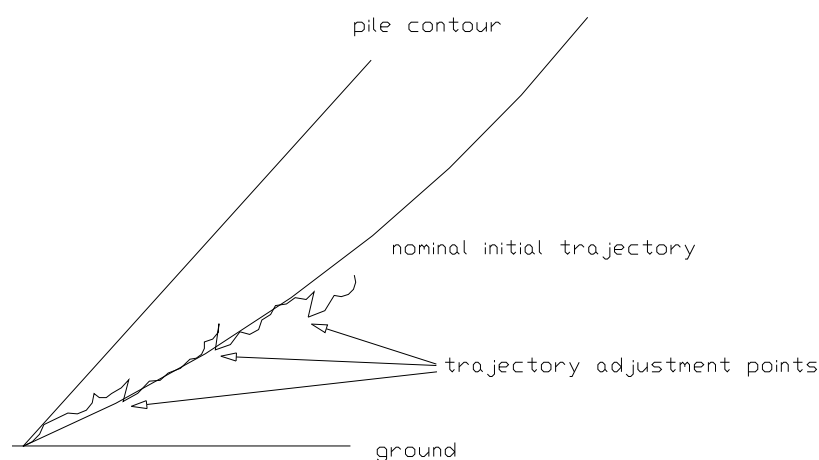

Fig. 13. Illustration of the effect of the conceptual control strategy

8. Concluding remarks

Although the advantages of auto-loading or automated excavation are obvious, and despite considerable work on the subject, a successful machine that can be readily purchased and put to work has not been reported. This implies the uncertainty about any method that has been tried at the industrial level, or that a method has not yet been tried. Alternatively this can be because of the priorities in industry and lack of interest, knowledge or both.

As far as the two-level control is concerned, an immediate conclusion at this point is the necessity of theoretical and experimental work towards investigation and formulation of the five different forces acting on the bucket at each point on the trajectory. This serves for the definition and approximation of a lower and higher range for force variation along the trajectory, in order to be employed for feedback reference values. This involves the studies for values and the variation of the five force components together with the point of action of each force. Out of these force elements the cutting force is the dominant member. Some of the works performed on this issue can be found in (Fabrichnyi, 1975, Balovnev, 1983,

Zelenine et al, 1985, Fielk & Riley, 1991, Hemami, 1994, Takahashi, et al, 1999). In fact plenty of research has been reported on the analysis of the forces in excavation and tillage. A review of all the work can be found in (Blouin et al, 2001).

Based on the conclusions in (Blouin et al, 2001), no uniform and well accepted definition, method or means to verify the results exists for formulation of the cutting force or other forces. A primary essential task is, then, a normalization and comparison of the previous work and comparison and validation of their results.

By the same token, an appropriate tool to verify the results of any control scheme for robotic excavation becomes desirable, in order to avoid the high cost of implementation of various control methods. As part of this, simulation software has been developed (Hemami & Hassani, 2007) for incorporating the behaviour of a medium during loading by a bucket. This software determines the resistive forces that work on a bucket when it moves through the medium when loading.

9. Summary

In this chapter the fundamentals of robotic excavation has been presented. This implies the modelling of an excavating machine as a robot and finding ways to control its motion, so that it can be programmed to automatically carry out an excavation task. The practice of modelling, kinematics, inverse kinematics, Jacobian relationships, etc. is the necessary work that must be repeated for each type of excavator. The present works in this chapter covers the matter for a front-end-loader or its underground counter part, a Load-Haul-Dump unit. The chapter points out the proposed methods for control of the process, although no final results are presented, since the matter can be still seen to be in its infancy stage. Analysis of the forces that a cutting tool or a bucket faces and must overcome during excavation has been done to some reasonable extent. But, this issue is by itself is very involved. An interested reader should consult the references given here for more detail.

10. References

- Balovnev, V.I. (1983), *New Method for Calculating Resistance to Cutting of Soil*, Amerind Publishing Co., New Delhi.
- Bernold, L. E. (1991), "Experimental Studies on Mechanics of Lunar Excavation", *Journal of Aerospace Engineering*, Vol. 4, No. 1 pp 9-23.
- Blouin, S, Hemami, A and M. Lipsett (2001), Review of Resistive Force Models for Earthmoving Processes, *Journal of Aerospace Engineering*, Vol. 14, No. 3, pp 102-111.
- Bullock, D. M., Apte, S. M. and Oppenheim, I. J. (1990), Force and Geometry Constraints in Robot Excavation, *Proc. Space 90 Conf. Part 2*, Albuquerque, pp 960-969.
- Denavit, J., and Hartenberg, R.S. (1955), A Kinematic Notation for Lower-Pair Mechanism Based on Matrices, *J. Applied Mechanics*, pp 215-221.
- Fabrighny, Y. F. (1975), Calculating the Resistance of Blasted Rock to Scooping by a Bucket, *Soviet Mining Review*, Vol 11, No. 4, pp 438-441.
- Fielke J. M. and Riley, T. W. (1991), The Universal Earthmoving Equation Applied to Chisel Plough Wings, *Journal of Terramechanics*, Vol 28, No. 1, pp 11-19.
- Hemami, A. (1992), Modelling Analysis and Preliminary Studies for Automatic Scooping/Loading in a Mechanical Loader, *Int. Journal of Surface Mining and Reclamation*, No 6, pp 151-159.

- Hemami, A. (1993), A Study of the Bucket Motion Trajectory for Automatic Scooping in LHD Loaders, *Trans. of the Institution of Mining and Metallurgy*, Vol. 102, A1-70, pp A37-A42
- Hemami, A. (1994), Study of Forces in the Scooping Operation of a Mechanical Loader, *Transactions of the CSME (Canadian Society of Mechanical Engineers)*, Vol. 18, No. 3, pp 191-205.
- Hemami, A. (1995), A Fundamental Analysis of Robotic Excavation, *J. of Aerospace Engineering*, Vol. 8, No. 4, pp 783-790.
- Hemami A. , Seward D.W. and Quayle S. (1999), Some experimental Force Analysis for Automation of Excavation by a Backhoe., *Proc. 16th Int Conf. on Automation and Robotics in Construction*, Madrid, Spain, pp 503-508
- Hemami, A and F. Hassani (2007), Simulation of the Resistance Forces Bulk Media to Bucket in a Loading Process, *Proc. 24th International Symposium on Automation and Robotics in Construction, ISARC 24*, India, pp 163-168
- Lee, C.S.G. (1982), "Robot Arm Kinematics, Dynamics, and Control", *IEEE Computer*, Dec. 1982, pp. 62-80.
- Michirev, P.A. (1986), Design of Automated Loading Buckets, *Soviet Mining Science*, Vol. 22, No. 4, pp 292-297.
- Ostoja-Starzewski, M. and Skibinievski, M. (1989), A Master-Slave Manipulator for Excavation and Construction Tasks, *Robotics and Autonomous Systems*, Vol 4, No 4, pp 333-337.
- Sarata, S., Osumi, H., Hirai, Y and Matsushima, G. (2003), Trajectory Arrangement of Bucket Motion of Wheel Loader, *Proc. ISARC 2003*, Eindhoven (Netherlands), pp 135-140.
- Sarata, S., Weeramhaeng. Y. and T. Tsubouchi (2005), Planning of scooping position and approach path for loading operation by wheel loader, *Proc. 22nd International Symposium on Automation and Robotics in Construction ISARC 2005 - September 11-14*, Ferrara (Italy)
- Seward, D, D Bradley and R Bracewell (1988), The Development of research models for automatic excavation, *5th Int. Symp. on Robotics in Construction*, Tokyo, Vol. 2, pp 703 - 708.
- Seward, D., Bradley, D., Mann, J. and Goodwin, M. (1992), Controlling an Intelligent Excavator for Automated Digging in Difficult Ground, *Proc. the 9th Int. Symp. on Aut. and Robotics in Construction*, Tokyo, pp 743-750.
- Shi, X, F-Y Wang and, P.J. A Lever (1995), Task and Behaviour Formulation for Robotic Rock Excavation, *Proc. 10th IEEE Int. Symp on Intelligent Control*, pp 247-253.
- Shi, X, Lever, P.J. A and F-Y Wang (1996), Experimental Robotic Excavation with Fuzzy Logic and Neural Networks, *Proc. IEEE Int. Conf. Robotics and Automation*, Vol.1, pp 957-962.
- Sing, S. (1991), An Operation Space Approach to Robotic Excavation", *Proc. IEEE Int. Symp. Int Control.*, NY, PP 481-486.
- Steel, J.P.H., King, R., and Strickland, W., (1991), Modelling and Sensor-Based control of an Autonomous Mining Machine, *Int. Symp. on Mine Mechanization and Automation*, Vol. 1: 6-55--6-67, Golden, Colorado.
- Stentz. A. et al (1999), Position Measurements for Automated Mining Machinery, Robotics Institute (Carnegie Mellon University).

- Takahashi, H., Hasegawa, M. and Nakano, E. (1999), Analysis on the resistive forces acting on the bucket of a Load-Haul-Dump machine and a wheel loader in the scooping task., *Advanced Robotics*, Vol 13, No 2, pp 97-114.
- Vaehae, P. K., Skibniewski, M. J. and Koivo (1991), Kinematics and Trajectory Planning for Robotic Excavation, *Proc. Construction Congress 91*, Cambridge, MA, pp 787-793.
- Wohlford, W. P., Griswold, F. D. and Bode, B. D. (1990), New Capability for Remote Controlled Excavation, *Proc. 38th Conf. on Remote Syst.*, Washington D.C., pp 228-232.
- Zelenin, A. N., Balornev, V. I. and Kerov, I. P. (1985), *Machines for Moving the Earth*, Amerind Publishing Co., New Delhi.

IntechOpen



Robotics and Automation in Construction

Edited by Carlos Balaguer and Mohamed Abderrahim

ISBN 978-953-7619-13-8

Hard cover, 404 pages

Publisher InTech

Published online 01, October, 2008

Published in print edition October, 2008

This book addresses several issues related to the introduction of automaton and robotics in the construction industry in a collection of 23 chapters. The chapters are grouped in 3 main sections according to the theme or the type of technology they treat. Section I is dedicated to describe and analyse the main research challenges of Robotics and Automation in Construction (RAC). The second section consists of 12 chapters and is dedicated to the technologies and new developments employed to automate processes in the construction industry. Among these we have examples of ICT technologies used for purposes such as construction visualisation systems, added value management systems, construction materials and elements tracking using multiple IDs devices. This section also deals with Sensorial Systems and software used in the construction to improve the performances of machines such as cranes, and in improving Human-Machine Interfaces (MMI). Authors adopted Mixed and Augmented Reality in the MMI to ease the construction operations. Section III is dedicated to describe case studies of RAC and comprises 8 chapters. Among the eight chapters the section presents a robotic excavator and a semi-automated façade cleaning system. The section also presents work dedicated to enhancing the force of the workers in construction through the use of Robotic-powered exoskeletons and body joint-adapted assistive units, which allow the handling of greater loads.

How to reference

In order to correctly reference this scholarly work, feel free to copy and paste the following:

Ahmad Hemami (2008). Robotic Excavation, Robotics and Automation in Construction, Carlos Balaguer and Mohamed Abderrahim (Ed.), ISBN: 978-953-7619-13-8, InTech, Available from:

http://www.intechopen.com/books/robotics_and_automation_in_construction/robotic_excavation

INTECH
open science | open minds

InTech Europe

University Campus STeP Ri
Slavka Krautzeka 83/A
51000 Rijeka, Croatia
Phone: +385 (51) 770 447
Fax: +385 (51) 686 166
www.intechopen.com

InTech China

Unit 405, Office Block, Hotel Equatorial Shanghai
No.65, Yan An Road (West), Shanghai, 200040, China
中国上海市延安西路65号上海国际贵都大饭店办公楼405单元
Phone: +86-21-62489820
Fax: +86-21-62489821

© 2008 The Author(s). Licensee IntechOpen. This chapter is distributed under the terms of the [Creative Commons Attribution-NonCommercial-ShareAlike-3.0 License](#), which permits use, distribution and reproduction for non-commercial purposes, provided the original is properly cited and derivative works building on this content are distributed under the same license.

IntechOpen

IntechOpen