

# We are IntechOpen, the world's leading publisher of Open Access books Built by scientists, for scientists

## 4,800

Open access books available

## 122,000

International authors and editors

## 135M

Downloads

Our authors are among the

## 154

Countries delivered to

## TOP 1%

most cited scientists

## 12.2%

Contributors from top 500 universities

**WEB OF SCIENCE™**Selection of our books indexed in the Book Citation Index  
in Web of Science™ Core Collection (BKCI)

Interested in publishing with us?  
Contact [book.department@intechopen.com](mailto:book.department@intechopen.com)

Numbers displayed above are based on latest data collected.

For more information visit [www.intechopen.com](http://www.intechopen.com)

# Precast Storage and Transportation Planning via Component Zoning Optimization

Kuo-Chuan Shih, Shu-Shun Liu and Chun-Nen Huang  
*National Yunlin University of Science and Technology  
Kainan University  
Taiwan (ROC)*

## 1. Introduction

Industry management issues, such as enterprise resource planning (ERP) and supply chain management (SCM), are discussed and implemented successfully in many manufacturing industries but construction. No matter what the nature of construction is manufacturing buildings, risks and uncertainties make its characteristic different to other manufacturing industries. In order to reduce effects of these two scourges, precast is an evolutionary method what is adopted to remove construction work environment from outdoor to indoor and make the procedure of component producing regular as an automatic factory. Thus, precast method is a construction method with its industrial characteristics being closest to those of manufacture industry. However, Practical plans and information identification in working process must be further recognized and achieved. This study proposes an optimization model which focuses on planning issues of precast manufacturing procedure.

The storage and transportation planning of a construction precast project is mainly discussed herein. Generally, whole process of a precast project can be divided into 5 stages: design, production, storage, transportation, and installation. Besides, at least 4 important roles: client, architect, subcontractor, and precast factory, are involved in these 5 stages. Relationships among these four roles depend on contracts of a project. From perspective of the precast factory, two stages are out of their control: design stage and installation stage. In design stage, the architect confirms details of all precast components, such as shape, strength and material, with the client, and then makes components exact. The precast factory receives these component details and then produces components according to architect's designs as orders. In installation stage, the subcontractor installs all completed components at where the places according to architect's design. The precast factory supplies components on time in the installation stage of most cases. It is obvious that the design stage and the installation stage involves two or more roles. Thus, production, storage, and transportation stage are more controllable than these two stages from precast factory's viewpoint. Furthermore, production stage was the issues most frequently investigated and analyzed in prior precast management related study. However, the planning of storage and transportation are still very significant to a precast factory. To complete the management mechanism of precast factory, these two stages need to be investigated.

## 2. Reference

There are many production stage related studies of precast related studies can be referred and enumerated. For example, Chan has studied a lot in precast production planning. In order to suit different standardization degrees of components, Chan (2002) has proposed two production planning models are comprehensive method, which the method utilizes resources regularly in component producing, and specialized method, which the method considers low standardization components, for factory business organization. Furthermore, a coordinated production scheduling and rescheduling model has proposed by Chan (2003, 2005) to deal with risks of component demand. Chan (2005) has adopted simulation to build scenarios of viaduct producing for analysis. Considering resource-constrained environment, Leu (2002) has proposed a GA base scheduling model that discussed the importance of manpower, cranes, steam curing capacity and reinforcement cage storage space. Besides, Viaduct precast considers both supply-demand matching and high productivity.

Storage and transportation planning issues of precast project have been few studied in construction field but manufacturing industry. Storage and transportation plan are two sides of a coin that are presented in many studies in manufacturing industry field. A common study type is the total cost optimization of transportation among factory, warehouse and customer. Furthermore, outsourcing of inventory and transportation may be related to time-base and quantity-base issues (Sila, 2006). For precast project, how to store a special object such as precast component which reduce secondary movement and component finding is a key question. The Acheson & Glover Group (2006) tried to develop a precast storage system. However, ways to store component are also related to safety of labor. For construction process issues in job-site, Hu (2005) proposed a geometric reasoning method that can help to determine the component sequence of demand. Nevertheless, characteristics of construction precast component: huge; heavy; unique in design or installation procedure cause these achievements cannot easily perform in precast factory.

One of problem of precast storage and transportation is huge component. However, containerization is an issue that is valuable to be explored. Vis and Koster (2002) discussed the process of transporting containers from ship to stack in terminal. Means are used to move huge objects, including cranes, vehicles, straddle carrier... etc. Thus, a plan to simplify the process and to use these means efficiently is necessary. Avriel (1998) proposed a mathematic model that tried to deal with the storage planning problem and reduce the shifts of container in a ship. However, the size of the precast component is not the only item to be concerned of one should also be concerned about the different shapes of the component. Sadiq (1996) proposed a cluster-analysis base model the classified all the objects into several sets, then allocated all the sets to different storage zones. This model tried to link the relationship between objects to reduce secondary-movement for objects. The cluster-analysis can also work in precast project and a cluster-analysis named zoning strategy in precast project will be discussed herein.

## 3. Precast component storage and transportation

Optimization is a usual tool for precast factory planning in previous production stage's researches. Thus, this research follows mathematical model discussion with more concern in storage and transportation stages.

### 3.1 Storage stage

Generally speaking, storage stage had been considered in the component producing planning but simplified as an inventory calculation. Daily inventory is a vehicle variable between component producing and the demand. Produced components are stored in factory as inventory and this inventory add up all produced components in factory in a period. In order to match the demand, the component inventory must equal to or exceed the demand of contract at the deadline of project. Thus, a component producing plan considers daily inventory is able to create, and it is still practical for factory business mainly considering production stage. Furthermore, the cost of inventory can be also calculated through the quantity of stored components, and the inventory limits can be restrained if storage space is further concerned as constraints. Nevertheless, traditional precast factory can perform this kind of production planning formulation without considering how to store components.

Component storage must be planned from perspective of a precast factory business. No matter how a precast factory closed to a manufacturing one, the nature of product of precast factory, construction component, is very unique to other industries. In addition, there are less consistent among components when component's sharp, strength and position of a building are in consideration. A component that is unique to any other one is commonly concerned in most construction precast project. Thus, to identify each component is usually important in storage stage. Furthermore, there are several circumstances must be regarded in practical storage work: size of components; limitation in vertical loading of ground; safe distance between components and ways to store components. Briefly, the problem of component storage is a 2-dimensional or 3-dimensional spatial allocation with component identification. These considerations cause component storage complex and identification of component is necessary. It is hard to ignore the storage stage to a precast factory business.

A good storage plan is also benefit to help component delivering in right order and on time. Two sequences are accompanied with component delivering are sequence from production stage to storage stage and sequence from storage stage to installation stage. In the first case, components and molds can be grouped that had mentioned by Chen 2005. In order to produce components smoothly and continually, Components which can be grouped into a same sharp, strength and material can be produced orderly by the same mold or grouped molds which belong to the same category certainly. Under this circumstance, components can be produced as soon as possible in production stage with minimal operation change of mold. This sequence is named production sequence, PS, in this research that means components are delivered according to their group. Besides, PS always causes grouped components storage. The other sequence is named installation sequence or IS. Components must be installed at the positions where they are appointed in architect's design. Thus, components which belong to the same scope of once installation work, for example a one-floor installation, are needed in a short moment. Therefore, components are delivered according to their demand timing from factory to installation worksite. By view of these two sequences, it can be recognize that there is a conflict between PS and IS in precast factory business. Therefore, the functionality of storage plan is not only a quantity calculation of component inventory, but rearrangement of component sequence from PS to IS to resolve this conflict before their installation.

Foreign site storage that component are stored in a space out of both factory and work site is another issue in practical factory business. When the space of the precast factory is insufficient to store all components, foreign site storage is a common alternative. Extra movements of components are needed to deliver components between different sites.

Foreign site storage refers that the precast factory has to look for other storage sites to store the components that cannot be stored in the precast factory during project period. This Foreign site storage issue combines component storage and transportation, and it is complex in both storage and transportation planning. This alternative occurs in practice. Therefore, further component planning and controlling mechanism in storage stage is needed to analysis all above issues for a precast factory.

### **3.2 Transportation stage**

Transportation stage is ignored in previous precast management researches. Components always produced with few redundancies in a construction precast project, and all of them must be transported for installation to meet project requirement. Therefore, the cost of transportation can be treated as a fixed cost in most cases without detail delivery consideration because component delivery is necessary in a project. Thus, component transportation has been a parameter of fix cost which does not need to plan. However, the component transportation still plays an important role in factory business.

There are two kinds of transportation must be recognized in factory business: component movement within a site and component transportation between two sites for a long distance. Component movement within a site means that components are moved within the factory, a storage site, or the work site in short distance. Equipments such as cranes and trams can be utilized for this case. These equipments are owned or rented for daily business by precast factory. Hence, transportation cost in this case can be neglected from single precast project or transformed onto the cost for factory or site setting cost. The other, component transportation for a long distance is performed by trucks. In practice, trucks are mostly rented case by case when components transport in sites or turn over from any site to work site are sure. Two important factors: weight of components and transported distance are commonly adopted for truck rental fee calculation. This long distance transportation is variable case by case. For example, components are delivered from the factory to a foreign site, the factory to the work site, and a foreign site to the work site.

## **4. Component zoning strategy**

Taking to above issues as well as problems with component storage and transportation into consideration, a mechanism for precast factory planning which employed the concept of basic zoning with minimization of total cost is purposed. The related definitions and assumptions are explained in the following sections:

### **4.1 Component Zoning**

Components are grouped into zones herein. A zone is a space that components can be stored following specific rules which assigned by planner. This component zoning is most like the behavior of the goods package in manufacturing that goods can be encased into a box by following rules of what kind of box it is. By the way, a box is both storage and transportation strategy basis. However, there is no real box for precast component, but it can be instead by a specified storage space as a zone without encasement. A zone is also similar to a container to collect components. Components can be moved in respectively. Therefore, the behavior of a zone is flexible that dependent on rules what the planner made to form it as a box or container. However, the rules of zones must be clearly declared before planning.



Zones are able to be alternated to release storage space too. This study mainly focus on how zoning strategy working in storage and transportation stage to represent component zoning. To recognize zoning rules is benefit for precast factory planning and management issue. Zones try to retain the flexibility of storage that planner can declare their own rule. Whole storage and transportation process can be formed by zones and their own rules. Zoning rules of a zone basically contain what kind of component can be stored, how many components can be stored, how much space are required and other specific rules what made by planner. Zoning rules help planner to control storage and transportation process because zones can force components well-regulated in preset rules. Thus, making zoning rules appropriate is a further important issue to meet the request of factory business management. The PS, to store grouped component, and IS, to store component by installation scope, are mainly discussed in component zoning herein.

The component zoning according to grouped component occurs in PS that is the common situation in practical storage business. To store components by group has several advantages: Components can be easily found; the space utility is well in most of cases; storage space demand can be easily calculated. This is why most factories which include all kinds of industry store goods by group of goods type for warehousing, and most of precast factories are working without exception. However, this kind of zoning strategy is not always suit precast factory storage. Hundred or thousand of component groups always occur because of architect's design.

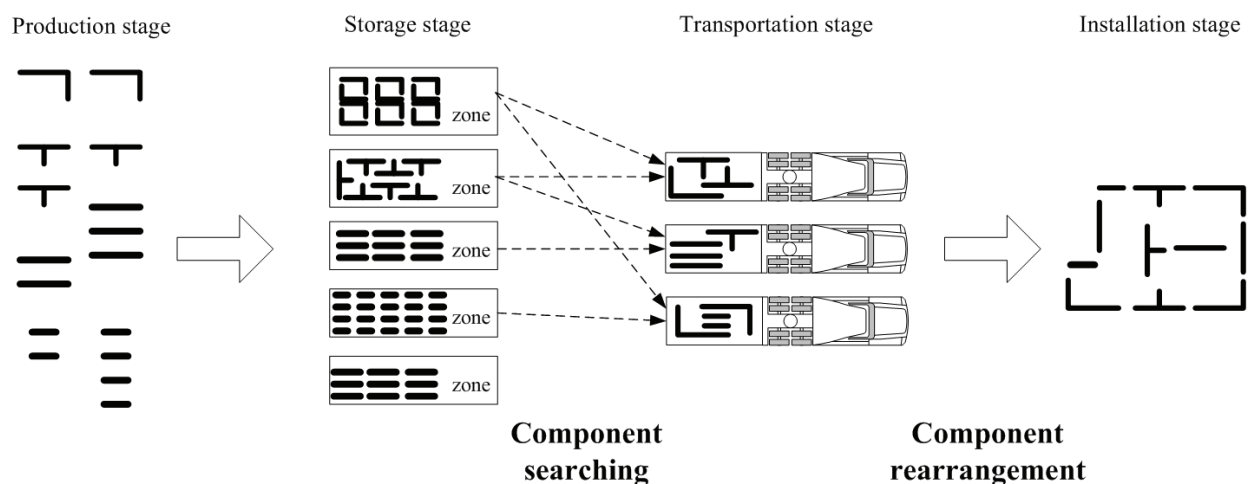

Fig. 1. Zones by following PS

Figure 1 shows a possible case of PS zoning rules and normal storage practice. Components are grouped and stored into zones in storage stage. However component searching or component rearrangement are needed before component installation because IS occurs after transportation stage. Trucks must find out required components through overall zones for component searching, or operations in work site must rearrange components before installation. Additional time and cost are caused in practical. Nevertheless, it can be also a choice in consideration.

Zoning with IS aim to overcome the conflict between PS and IS in factory. Component movement within a site is easier and cheaper than long distance transportation of trucks because cranes and trams can move and rearrange components conveniently. Thus, only component rearrangement is needed in storage stage. Figure 2 shows this situation.

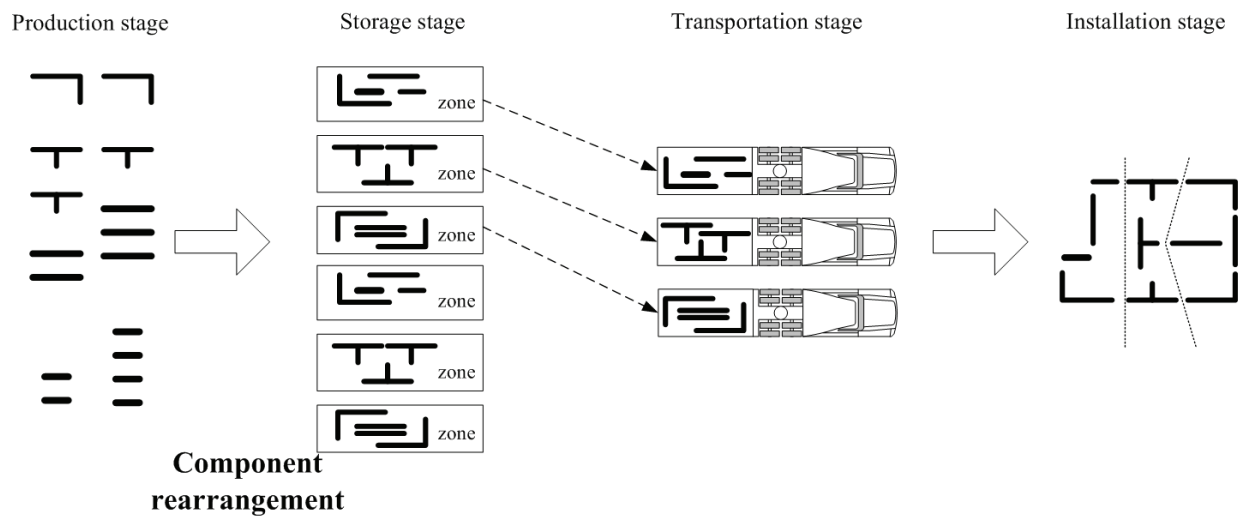

Fig. 2. Zones by following IS

#### 4.2 Zoning strategy

A zoning strategy is composed by zones what are chose for a storage and transportation plan during a planned period. Thus, a zoning strategy can contain zones with same rules, zones with different rules, mutualism zones, and mutually exclusive zones if they are needed. All zones whether PS or IS are alternatives when planner do not really recognize what kind of zone rules are suitable before practice. Planner can create kinds of zones and manifold rules in zones if they are recognized before or during decision making procedure. An optimization model for seek out the optimal zoning strategy with minimal operation cost of precast factory in storage stage and transportation stage by zone selection and allocation is proposed as below.

#### 4.3 Zone selection and allocation

From perspective of component storage, zones are used as basis elements for checking the component storage and utility of each storage site. In order to form an optimized zoning strategy, procedure of picking up appropriate zones, in term of zone selection, is very important. Figure 3 shows a possible situation of zone selection. First at all, components must be collected into zones following the rules of each zone is a basic assumption. This assumption makes sure that whole process of component storage can be represented by zones. Beside, whole inventory space is divided into sites. Two kinds of site that are site inside factory and foreign site are involved according foreign site inventory behaviour, extra site rental fee are considered if a foreign site is adopted during the period of a project. This rental fee contains land usage fee and necessary facility fee to operate storage business. Besides, truck rental fee can also be recognized by location of a foreign site and weight of component which are planned to store in this site.

The zone selection can be explained as relationships among components and zones. Components must be stored for sure, so that at least one zone must exist whenever any components are stored in. In other word, this zone is adopted when any component is planed to be stored in. For example, zone 1, 2, 3, and 5 in figure 3 are selected to store components. On the contrary, zone 4 is not selected to store any component. Besides, component can be stored into a zone when only they are permitted by rules of this zone.

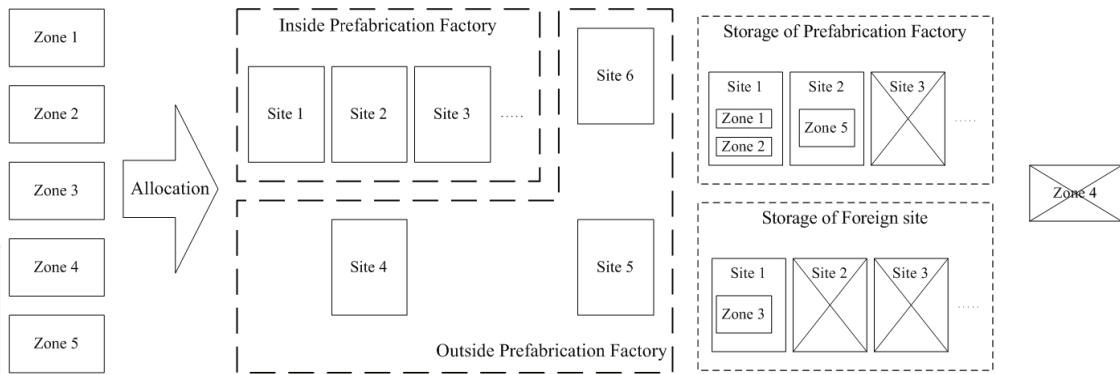

Fig. 3. Illustration of the Relationship among Zones and Storage Sites

The zone allocation can also be present as relationship among zones and sites. As the same circumstance, at least one site must be used or rented because there is at least one zone must be adopted to store components. A zone can be allocated into a site, no matter site inside factory or foreign site, when the storage space of this site is sufficient. The required storage space of this zone is according as its zone rules. Site inside factory or foreign site is allowed to allocate zones, but one zone can be only allocated once and into one site during a planed period. Figure 3 shows that site 1 and site 2 inside factory are occupied by zone1, zone 2 and zone5, and foreign site 1 is occupied by zone 3 respectively. It is allowed that two or more zones allocated in a site. Besides, whenever a foreign site is selected, the rental fee that contains land usage fee and the charge of necessary resource to operate storage business will be added into project cost for entire project period.

**4.4 Transportation between sites**

The whole transportation problem can be divided into 3 layers component movement according to zone allocation that mention above are: 1. Factory, in other word production stage, to sites inside factory; 2. sites inside factory to foreign site; 3. sites to work site, in other word installation stage. The route of component transportation diagram is shown in figure 4 as follows:

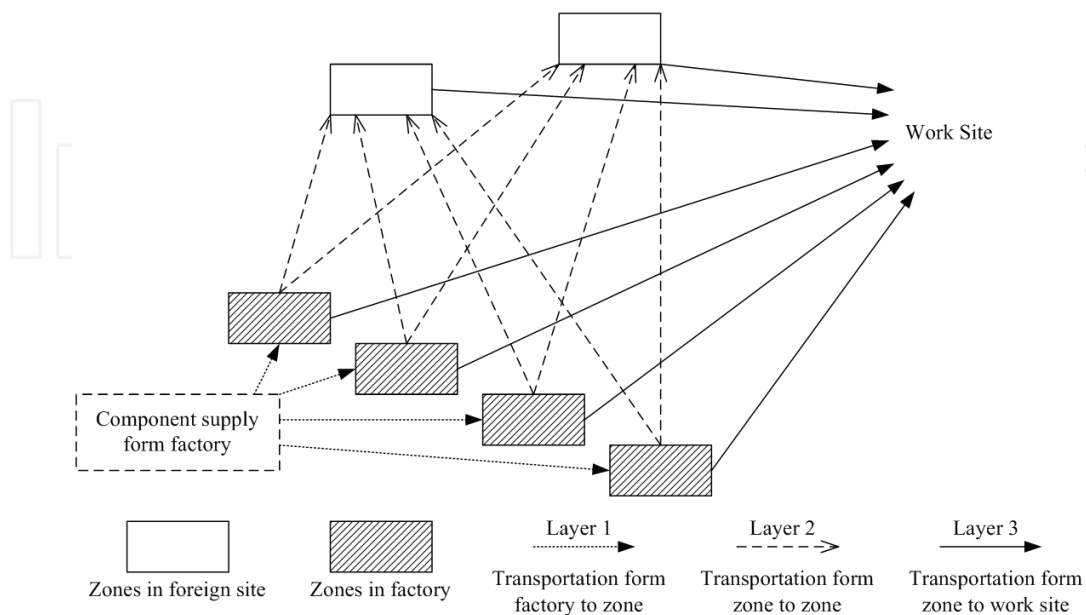

Fig. 4. Component transportation layer



Two types of transportation, within a site and long distance transportation, can be identified into these 3 movements. The case of transportation within the same site occurs when components are moved from factory to sites inside factory, layer 1, obviously. No extra transportation cost will be charged because these movements are completed by equipments belonging to factory. The other, long distance movement occurs in layer 2 and 3 and the truck rental fee according to weight of components and distance between sites will be charged.

## 5. Storage-transportation optimization model

### 5.1 Cost classification of model

Base on the proposed component zoning method, the whole procedure of component storage and transportation can be integrated and transferred into a problem of zone selection and allocation. A mathematic optimization model that belong to mix-integer planning, MIP, has been developed. The objective function of this model is to minimize total cost in whole storage and transportation stage of precast factory. Inventory cost has been further divided into two parts, inside and outside factory, that presented as function (2) are site fee of selected sites. In addition, the transportation cost has been divided into at least three parts that presented as function (3) according to different truck rental fee calculation. The structure and classification show as fig 5.

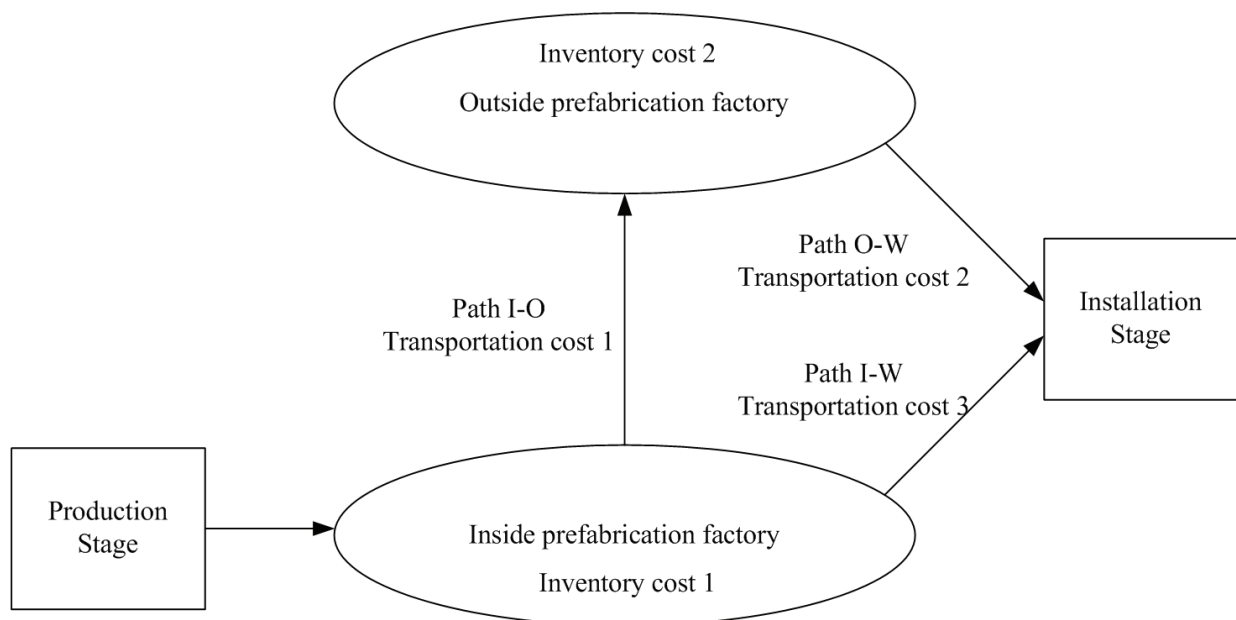

Fig. 5. Cost Classification Chart of the Model

$$\text{Objective function} \quad \text{Minimize } Total\_Cost = IC + TC \quad (1)$$

Where IC is the sum cost in storage stage and TC is the sum cost in transportation stage.

$$IC = \sum_i^{np} UP_i * pcs_i + \sum_j^{ni} UI_j * ics_j \quad (2)$$

Where  $i$  is the index of each site inside factory;  $np$  is the total number of sites inside factory;  $UP_i$  are binary variables for judgment of usage for each site  $i$  by 0 or 1;  $pcs_i$  are parameters of site maintain or holding cost of each site when  $UP_i$  are value 1;  $j$  is the index of each foreign site;  $ni$  is the total number of foreign site;  $UI_j$  are binary variables for judgment of site usage for each site  $j$  by 0 or 1;  $ics_j$  are parameters of site rental and holding cost of each site when  $UI_j$  are value 1.

$pcs_i$  and  $ics_j$  are fixed in consideration of single precast project. Besides, foreign site must be rented until project is completed.

$$TC = \sum_k^{ns} \sum_l^{ns} \sum_m^{ct} \sum_n^p TSQ_{k,l,m,n} * (tc1_m + tc2_m) + \sum_k^{ns} \sum_l^{ns} \sum_m^{ct} \sum_n^p (d_{m,n} - TSQ_{k,l,m,n}) * tc3_m \quad (3)$$

Where  $k$  and  $l$  are both the index of zone. These two parameters present the index of zone that components are transported from and components are transported to respectively when transportation between zones occurs. These situations occur in transportation between sites from inside factory to foreign site;  $ns$  is the total number of zones;  $m$  is the index of component type considering its sharp, weight and strength;  $ct$  is the total number of component type;  $n$  is the index of project time by working days;  $p$  is total working days of whole project period;  $TSQ_{k,l,m,n}$  are positive variables to calculate the quantity of component transportation between zones;  $tc1_m$  are parameters of component transportation cost between zones which are calculated by distance and weight of component;  $tc2_m$  are the parameters of component transportation cost from foreign site to worksite which are calculated by distance and weight of component;  $d_{m,n}$  are parameter of component demand of worksite which present component type and working day as a two dimension matrix;  $tc3_m$  are the parameters of component transportation cost from sites inside factory to worksite which calculation by distance and weight of component.

The demand of components is fixed after design stage of a project. In addition, there are 2 paths the components can be only transported by zones inside factory to worksite through foreign site or zone inside factory to worksite directly. The component demand, parameter  $d_{m,n}$  of worksite is equal to sum of the component number which transported through these 2 paths and also equal to total sum of produced component of a project in main consideration. Beside, foreign site are rented till the end of project and cannot retain component. Thus, the quantity of transported component from site inside factory to foreign site is equal to the quantity of transported component from foreign site to worksite.

Constraints:

Function (4) - (8) present rules of zone selection and allocation in whole project period.

Judging of site usage

$$\forall i \quad M * UP_i \geq \sum_k^{ns} \sum_n^p SLP_{k,i,n} \quad (4)$$

$$\forall j \quad M * UI_j \geq \sum_k^{ns} \sum_n^p SLI_{k,j,n} \quad (5)$$

Where  $M$  is a parameter with infinity value named big  $M$  in IP;  $SLP_{k,i,n}$  are binary variables for zones are allocated into the sites  $i$  which inside factory on day  $n$ .  $SLI_{k,j,n}$  are binary variables as  $SLP_{k,i,n}$  for foreign site  $j$ .

Zone allocation limit 1: Each zone cannot be located in more than one site at the same time.

$$\forall k, n \quad \sum_i^{np} SLP_{k,i,n} + \sum_j^{nj} SLI_{k,j,n} \leq 1 \quad (6)$$

Zone allocation limitation 2: No zone's movement can be made after zone allocation.

$$\forall k, i, n \quad SLP_{k,i,n} \geq SLP_{k,i,n-1} \quad (7)$$

$$\forall k, j, n \quad SLI_{k,j,n} \geq SLI_{k,j,n-1} \quad (8)$$

Function (9) – (10) present the space limit of each site for zone allocation. In most practical case, the unit of space is square meter.

Site space limit:

$$\forall i, n \quad pa_i \geq \sum_k^{ns} (SLP_{k,i,n} * sa_k) \quad (9)$$

$$\forall j, n \quad ia_j \geq \sum_k^{ns} (SLI_{k,j,n} * sa_k) \quad (10)$$

Where  $pa_i$  are parameters of space limit of site  $i$  inside factory;  $sa_k$  are parameters of space requirement of zone  $k$ ;  $ia_j$  are parameters of the space limit of foreign site  $j$ .

Function (11) presents that only when the zone is inside the precast factory can acquire component from production stage.

Supply acquisition Limit:

$$\forall k, m, n \quad \sum_i^{np} M * SLP_{k,i,n} \geq SS_{k,m,n} \quad (11)$$

Where  $SS_{k,m,n}$  are variables to calculate the quantity of component which acquire from production stage on day  $n$ .

Function (12) presents that only the zone inside factory can keep component at the end of project.

Final inventory control:

$$\forall k, m \quad \sum_i^{np} M * SLP_{k,i,n} \geq IS_{k,m,period} \quad (12)$$

Where  $IS_{k,m,period}$  are variables that the component quantity stored in each zone at the end of project; period is a parameter of index n to present the last working day of project. Function (13) presents that all components produced in production stage should be first moved into zones which are allocated in sites inside factory.

Supply allocation:

$$\forall m, n \quad \sum_k^{ns} SS_{k,m,n} = sc_{m,n} \quad (13)$$

Where,  $sc_{m,n}$  are parameters for the quantity of component in type m which produced in production stage on day n.

Function (14) presents that every zone can have initial inventory at the beginning of project. This function retains the flexibility in multiple project planning and rescheduling issue.

Initial inventory of zone:

$$\forall k, m \quad IS_{k,m,0} = ois_{k,m} \quad (14)$$

Where,  $ois_{k,m}$  are parameters for quantity of component m which stored in zone k at the beginning of project.

Function (15) presents that daily inventory calculation of components which stored in each zone.

Daily inventory:

$$\forall k, m, n \quad IS_{k,m,n} = IS_{k,m,n-1} + SS_{k,m,n} + \sum_l^{ns} TSQ_{l,k,m,n} - \sum_l^{ns} TSQ_{k,l,m,n} - TWQ_{k,m,n} \quad (15)$$

Where,  $TWQ_{k,m,n}$  are variables for quantity of component m which stored in worksite on day n.

Function (16) presents as the base zoning rules that the quantity of component which is stored in a zone can not exceed the component quantity limit of this zone.

Zone storage limit:

$$\forall k, m, n \quad IS_{k,m,n} \leq msq_{k,m} \quad (16)$$

Where,  $msq_{k,m}$  are parameters for the maximum component quantity in zone m.

Functions (17)-(20) present inventory relationships in working site.

Initial inventory of worksite:

$$\forall m \quad IW_{m,n} = oiw_m \quad (17)$$

Where,  $oiw_m$  are parameters of initial inventory of component m which are stored in worksite at the beginning day of project.

Daily inventory of worksite:

$$\forall m, n \quad IW_{m,n} = IW_{m,n-1} + \sum_k^{ns} TWQ_{k,m,n} - d_{m,n} \quad (18)$$

Limit of component in worksite storage:

$$\forall m, n \quad IW_{m,n} \leq mwq_m \quad (19)$$

Where,  $mwq_m$  are parameters for limit of components which the max quantity of component can store in worksite.

Final inventory of worksite:

$$\forall m \quad IW_{m,p} = 0 \quad (20)$$

Functions (21)-(23) are detail constraints of transportation between zones to make transportation path of component follow as fig. 4.

Zone Transportation Limit 1:

$$\forall k, m, n \quad TSQ_{k,k,m,n} = 0 \quad (21)$$

Transportation within a site is not allowed

Zone Transportation Limit 2:

$$\forall k, n \quad \sum_i^{np} SLP_{k,i,n} * M \geq \sum_l^{ns} \sum_m^{ct} TSQ_{k,l,m,n} \quad (22)$$

Zones in foreign site are not allowed to transport components to other zones.

Zone Transportation Limit 3:

$$\forall k, n \quad \sum_j^{ni} SLI_{k,j,n} * M \geq \sum_l^{ns} \sum_m^{ct} TSQ_{k,l,m,n} \quad (23)$$

The storage zones inside the factory are not allowed to accept any components transported from zones.

All related variables and parameters in the proposed model are positive integers.

## 5.2 Solving tool

The optimization model proposed herein can be modeled and solved by most of mathematical programming tools. This study adopts ILOG OPL program that contains a mathematic optimization engine named CPLEX to solve the proposed model.

## 6. Experiment of model

### 6.1 Input data

In order to verify the accuracy of the model proposed in this study, an experiment is presented by using a small case study. Data include environmental parameters such as production supply, demand information of worksite and rules of zoning strategies, as shown in Table 3 as follows:



Symbol	Value	
$np$	2 (sites)	
$ni$	3 (sites)	
$ns$	3 (zones)	

Symbol	Value		
$ct$	3 (types)		
$p$	7 (days)		

	Site 1 inside factory	Site 2 inside factory
$pcs_i$	18,000	30,000
$pa_i$	1,500	2,500

	site 1 outside factory	site 2 outside factory	site 3 outside factory
$ics_j$	100,000	50,000	25,000
$ia_j$	5,000	3,000	2,000

	Com 1	Com 2	Com 3
$oiw_m$	0	0	0
$mwq_m$	5	5	5
$tc1_m$	60	60	70
$tc2_m$	350	350	450
$tc3_m$	350	350	450

	Zone 1	Zone 2	Zone 3
$sa_k$	2,000	2,000	2,500

	Zone #	Com 1	Com 2	Com 3
$ois_{k,m}$	1	0	0	0
	2	0	0	0
	3	0	0	0
$msq_{k,m}$	1	0	0	25
	2	0	0	20
	3	10	10	20

	Com #	Day 1	Day 2	Day 3	Day 4	Day 5	Day 6	Day 7
$d_{m,n}$	1	0	0	0	0	0	10	0
	2	0	0	0	0	0	10	0
	3	0	0	0	0	0	0	30
$sc_{m,n}$	1	0	0	0	10	0	0	0
	2	0	0	5	0	5	0	0
	3	10	10	5	0	5	10	0

Table 1. Related Input Parameters of a Case Study

6.2 Output results

The objective value of optimal solution is 76,550 that contains the inventory cost is 55,000 and the transportation cost is 21,550. The details of the optimization solution for variables can be presented as follow:

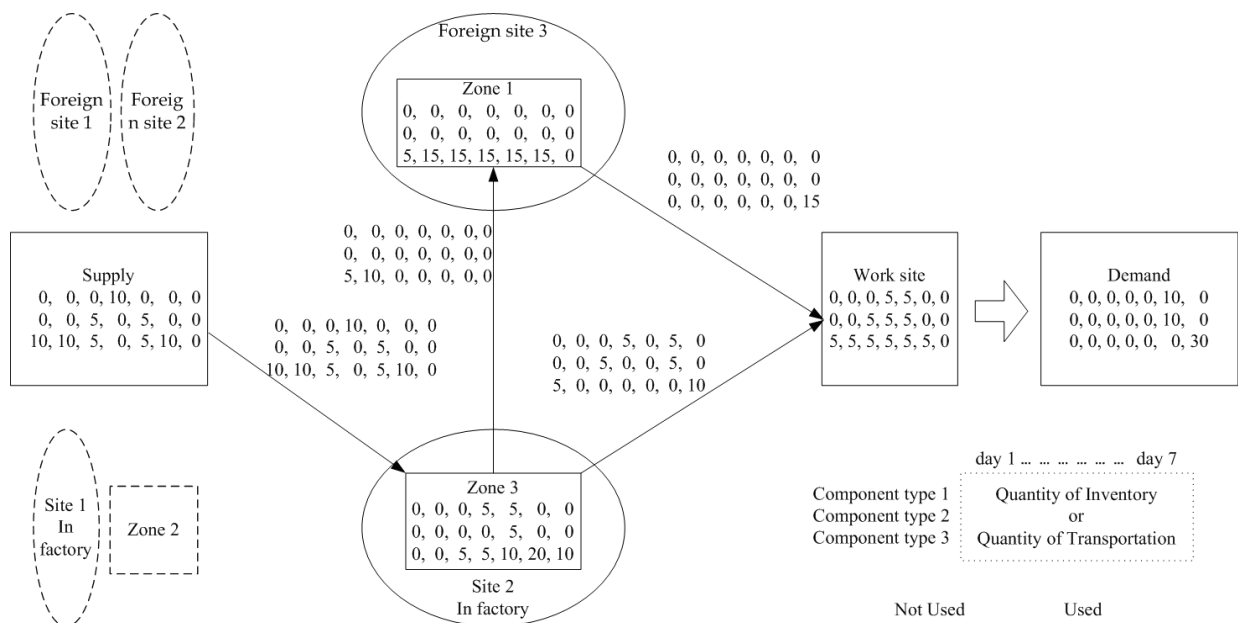

Fig. 7. Output of case experiment

This case experiment is not complex enough to match a practical situation of precast factory business. However, it is easier to explain how the proposed model works and how the zone strategy are formed according to data in table III. A supply-demand relationship that three components' demand of installation and supply of production are identified by array  $d_{m,n}$  and  $sc_{m,n}$ . Component quantity of supply exceeds demand to form a pure case of storage and transportation problem that components is sufficient and some of them will be residual at end of considered period. Figure 7 shows whole storage and transportation information.

In order to store components, zone selection and allocation must be done before any other decisions. However, 3 zones with their rules of  $msq_{k,m}; sa_k$  and 5 sites that their rental fee:

$pcs_i; ics_j$  and storage space:  $pa_i; ia_j$  are known in consideration. Zone 1 and zone 3 are

selected during optimization proceed and they are allocated into site 2 inside factory and foreign site 3 respectively to meet the objective function. By the way, zone 2, site 1 inside factory, foreign site 1 and foreign site 2 are not adopted. All this decisions assembles the best zoning strategy. It is one of important purposes of this research that planners do not fully recognize how to store all components they have, but some clues of zoning rules are known according to their experience of factory business. In this model, all kinds of zones with their own rules that can be considered as parameter or constraints, and several foreign sites that can be use to assist factory in storing components are allowed. In addition, the best zoning strategy will be picked out through this optimization model. In order to avoid unnecessary limit of zoning strategy forming, planner can consider a great quantity of zones with possible rules. However, additional zones and sites will cause more calculation efforts are needed, but a planner with experience is supposed to screen impossible zones and sites to make all parameters reasonable.

Transportation issue can be further resulted after zone allocation. Thus, vehicle path is also determined with certain transported component. This model avoids unnecessary component movement according to function 21-23. That is why zone 1 stores only 15 components although  $msq_{1,3}$  is equal to 25. All other components are transported to worksite directly.

Repeat the optimization process is encouraged to refine the zone strategy because unsuitable zone may occur. The example of zone 1 that mention before implies rules of zone 1 need to be adjusted if able or other suitable zone can be argued because it is not fulfilled during the considered period. Zones of this case study are superficial. However, the output can assist planner to refine their zone strategy with their experience or the latest optimized zoning strategy.

PS and IS are not only two choices of zone types but they are practical. In this case study, zone 1 and zone 2 can be classified into PS because only component 3 can be stored in but zone 3 is relaxed. This study retains possibilities of zones in order to meet kinds of storage environment or ways to store component. Of course, PS and IS are included. However PS always occurs in production stage and IS in installation stage. No matter how varied zone strategy is formed, PS and IS still exist even the conflict between them. To a practical zone strategy, zones that contain PS and IS are encouraged.

The whole process of solution finding took 0.46 seconds only with 1.6GHz CPU and 768 MB RAM of computer. It implies that despite the complicatedness of constraints, which contained 594 constraints and 523 variables, the model could still obtain optimized results. The solving screen of the model is shown in Figure 5 as below:

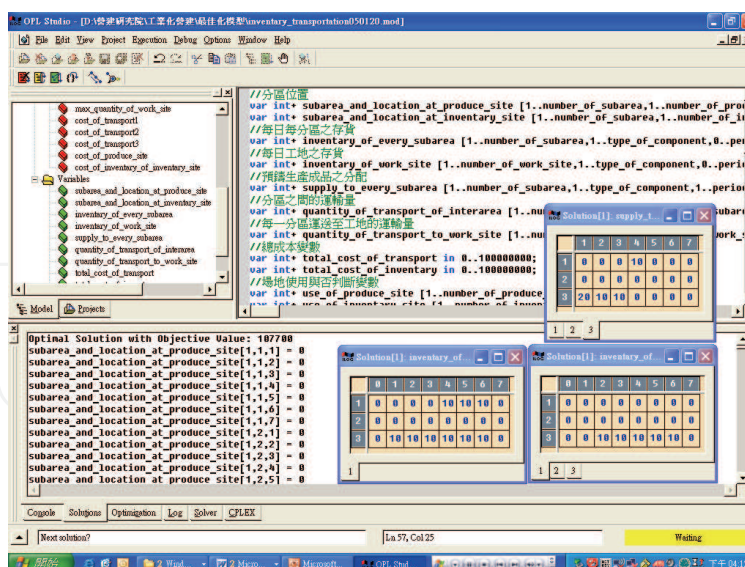

Fig. 8. Screen of Solving by ILOG OPL

## 7. Conclusion

Storage and transportation of precast component are quite practical issues. This study tries to point out its importance through PS and IS discussions, and an optimization model is proposed to refine a best zoning strategy through zone selection and allocation procedure. This model is proved that it can be executed and obtain solutions effectively.

To create zones with practical and significant rules is important to perform this proposed model, and then zones will be confirmed for best zone strategy. This model is used as means to assist planner approaching a beneficial decision of precast factory in storage and transportation stage. Nevertheless, to set rules of each zone based on planner's experience is still critical.

## 8. References

- Chan, W. T. & Hao, H. (2002). Constraint programming approach to precast production scheduling, *Journal of Construction Engineering and Management*, Vol. 128, No. 6, November/December pp. 513-521.
- Sou-Sen Leu & Shao-Ting Hwang (2002). GA-based resource-constrained flow-shop scheduling model for mixed precast production. *Automation in Construction*, Vol. 11, Issue 4, pp. 439- 452.
- Weng-Tat Chan & Zhen Zeng (2003). Coordinated production scheduling of prefabricated building components, *Construction Research Congress - Wind of Change: Integration and Innovation*.
- W. T. Chan & Hao Hu (2002). Production scheduling for precast plants using a flow shop sequencing model, *journal of computing in civil engineering*, Vol. 16, No. 3, July 2002, pp. 165-174.
- Weng-Tat Chan and Zhen Zeng (2005). Rescheduling precast production with multiobjective optimization, *Computing in Civil Engineering*.
- Wenfa Hu (2005). Automatic construction process of prefabricated buildings on geometric reasoning, *Construction Research Congress 2005: Broadening Perspectives*.

- Wah-Ho Chan & Ming Lu (2005). Logistics and operations simulation in precast viaduct construction: case study, *Computing in Civil Engineering*.
- Luisa Equi & Giorgio Gallo & Silvia Marziale & Andres Weintraub (1997). "A combined transportation and scheduling problem", *European Journal of Operational Research*, Vol. 97, Issue 1, pp. 94-104.
- Sila Cetinkaya & Fatih Mutlu & Chung-Yee Lee (2006). A comparison of outbound dispatch policies for integrated inventory and transportation decisions, *European Journal of Operational Research*, Vol. 171, Issue 3, pp. 1094-1112.
- Acheson & Glover, Precast storage system,  
[http://www.acheson-glover.com/constructionpro/precast/storage\\_systems](http://www.acheson-glover.com/constructionpro/precast/storage_systems).
- New Zealand the Department of Labour (2006). Unsafe A-frames used for transportation and storage of precast concrete panels, *Accident Alert*. No. 13.
- Iris F.A. Vis & René de Koster (2003). Transshipment of containers at a container terminal: An overview, *European Journal of Operational Research*, 147 1-16.
- Mordecai Avriel & Michal Penn & Naomi Shpirer & Smadar Witteboon (1998). Stowage planning for container ships to reduce the number of shifts, *Annals of Operations Research*, 7655 - 71.
- Sadiq, M. B. & Landers, T. L. & Taylor, G. D. (1996). An assignment algorithm for dynamic picking systems, *IIE Transactions*, Vol. 28, pp. 607-616.

IntechOpen



## **Robotics and Automation in Construction**

Edited by Carlos Balaguer and Mohamed Abderrahim

ISBN 978-953-7619-13-8

Hard cover, 404 pages

**Publisher** InTech

**Published online** 01, October, 2008

**Published in print edition** October, 2008

This book addresses several issues related to the introduction of automaton and robotics in the construction industry in a collection of 23 chapters. The chapters are grouped in 3 main sections according to the theme or the type of technology they treat. Section I is dedicated to describe and analyse the main research challenges of Robotics and Automation in Construction (RAC). The second section consists of 12 chapters and is dedicated to the technologies and new developments employed to automate processes in the construction industry. Among these we have examples of ICT technologies used for purposes such as construction visualisation systems, added value management systems, construction materials and elements tracking using multiple IDs devices. This section also deals with Sensorial Systems and software used in the construction to improve the performances of machines such as cranes, and in improving Human-Machine Interfaces (MMI). Authors adopted Mixed and Augmented Reality in the MMI to ease the construction operations. Section III is dedicated to describe case studies of RAC and comprises 8 chapters. Among the eight chapters the section presents a robotic excavator and a semi-automated façade cleaning system. The section also presents work dedicated to enhancing the force of the workers in construction through the use of Robotic-powered exoskeletons and body joint-adapted assistive units, which allow the handling of greater loads.

### **How to reference**

In order to correctly reference this scholarly work, feel free to copy and paste the following:

Kuo-Chuan Shih, Shu-Shun Liu and Chun-Nen Huang (2008). Precast Storage and Transportation Planning via Component Zoning Optimization, *Robotics and Automation in Construction*, Carlos Balaguer and Mohamed Abderrahim (Ed.), ISBN: 978-953-7619-13-8, InTech, Available from:

[http://www.intechopen.com/books/robotics\\_and\\_automation\\_in\\_construction/precast\\_storage\\_and\\_transportation\\_planning\\_via\\_component\\_zoning\\_optimization](http://www.intechopen.com/books/robotics_and_automation_in_construction/precast_storage_and_transportation_planning_via_component_zoning_optimization)

**INTECH**  
open science | open minds

### **InTech Europe**

University Campus STeP Ri  
Slavka Krautzeka 83/A  
51000 Rijeka, Croatia  
Phone: +385 (51) 770 447  
Fax: +385 (51) 686 166

### **InTech China**

Unit 405, Office Block, Hotel Equatorial Shanghai  
No.65, Yan An Road (West), Shanghai, 200040, China  
中国上海市延安西路65号上海国际贵都大饭店办公楼405单元  
Phone: +86-21-62489820  
Fax: +86-21-62489821



[www.intechopen.com](http://www.intechopen.com)

IntechOpen

IntechOpen

© 2008 The Author(s). Licensee IntechOpen. This chapter is distributed under the terms of the [Creative Commons Attribution-NonCommercial-ShareAlike-3.0 License](#), which permits use, distribution and reproduction for non-commercial purposes, provided the original is properly cited and derivative works building on this content are distributed under the same license.

IntechOpen

IntechOpen