

We are IntechOpen, the world's leading publisher of Open Access books Built by scientists, for scientists

4,800

Open access books available

122,000

International authors and editors

135M

Downloads

Our authors are among the

154

Countries delivered to

TOP 1%

most cited scientists

12.2%

Contributors from top 500 universities



WEB OF SCIENCE™

Selection of our books indexed in the Book Citation Index
in Web of Science™ Core Collection (BKCI)

Interested in publishing with us?
Contact book.department@intechopen.com

Numbers displayed above are based on latest data collected.

For more information visit www.intechopen.com



New Trends in Evaluation of the Sensors Output

Michal Pavlik, Jiri Haze and Radimir Vrba
*Brno University of Technology
 Czech Republic*

1. Introduction

The area of physical quantity processing in recent sensoric applications demands for high accuracy, low distortion, fast response and low power consumption. There are many physical quantities, which could be processed, mainly pressure, temperature, humidity etc. The pressure processing is one of the most important issues for designers. There exist many problems, which have to be solved i.e. how to measure relative and absolute pressure, how to process signal from sensor with low amplitude, how to withdraw noise and parasitics and so on.

The pressure is usually measured using capacitive principle (Lee & Wise., 1982), (Chavan & Wise, 2001), (He et al., 2007). The capacitor is formed by measuring membrane and substrate, see Fig. 1. When the pressure is applied, the membrane is deformed and the distance between membrane and substrate changes. It causes the change of capacity, which is processed in next stages.

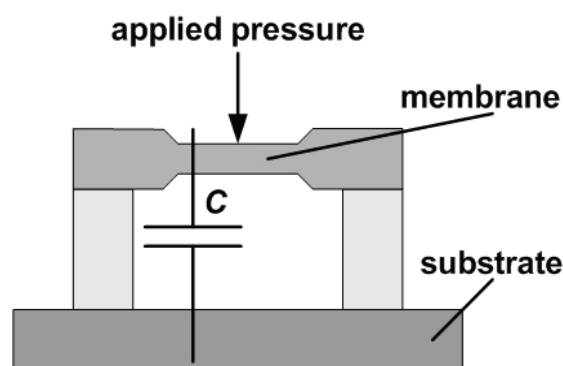

Fig. 1. Capacitive principle of pressure measurement

The capacity is defined as

$$C = \varepsilon_0 \varepsilon_r \frac{S}{d} \quad (1)$$

where C is measured capacity, ε_0 is permittivity of vacuum, ε_r is relative permittivity of the material (usually silicium), S is working area of the capacitor (membrane) and d is distance between membrane and substrate. This kind of structure could be modified for differential pressure measurement, where the measurement is accomplished by a pair of the sensing capacitors (Burczyk et al. 2002).

Source: Robotics, Automation and Control, Book edited by: Pavla Pecherková, Miroslav Flidr and Jindřich Duník,
 ISBN 978-953-7619-18-3, pp. 494, October 2008, I-Tech, Vienna, Austria

The standard differential capacity half bridge, which represents the pressure sensor, includes several parasitics (Fig. 2). There are mainly parasitic capacity C_{DP} , which is formed between top plate of C_{D+} and bottom plate of C_{D-} , the inductance of the wires L_{D+}, L_{D-} between C_{D+}, C_{D-} and their pins and resistance R_{D+}, R_{D-} between C_{D+}, C_{D-} and ground. These parasitics have to be taken into account, when the processing method and circuits are designed.

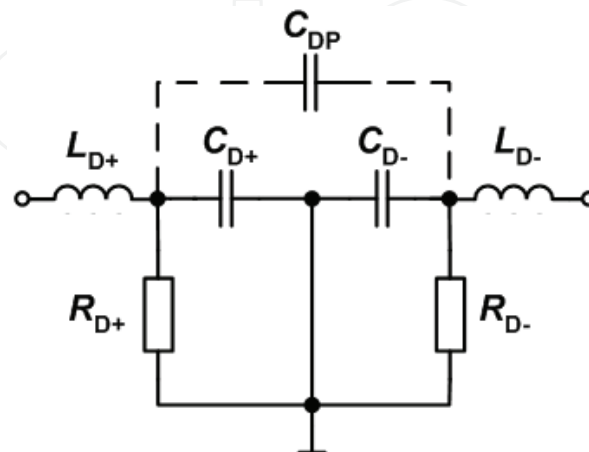

Fig. 2. Parasitics in differential pressure sensor

The ordinary value of the differential capacitors varies from units to hundreds of pF. The high measurement accuracy is important issue. Therefore the AD conversion with resolution of 16 bits or better is usually required. The measurement in order of fF is needed, because of the AD converter high accuracy. However these values are very low, so their measurement is very difficult.

Basically there are two well-known possibilities of pressure measurement. One is based on utilization of AD 7745 chip from Analog Devices Inc., which is capacitance-to-digital number converter (Whytock, 2005). The second is based on measurement using 555 timer/counter principle (Pavlik et al. 2007).

The block diagram of the principle, which uses AD 7745 chip is depicted in Fig. 3. The capacity C_x , which represents changes of pressure, is directly measured by the AD 7745. Since this chip includes sigma-delta converter, the accuracy of measurement is very high. The output digital signal is processed by microcontroller afterwards. Since this chip also includes temperature sensor, it is possible to realize temperature compensation of the output.

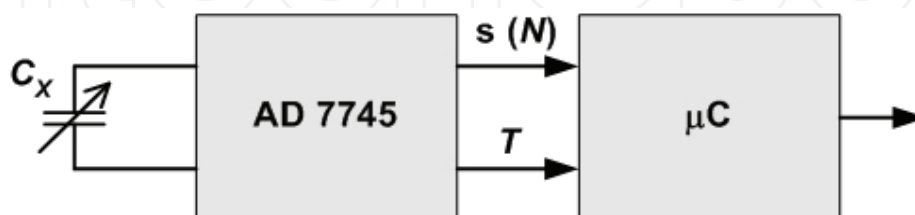

Fig. 3. The block diagram of the measurement principle using AD 7745

The method based on 555 timer/counter works as follows – Fig. 4. The signal processing of the differential pressure sensor is realized by a pair of oscillators. The oscillators are based on the two basic 555 circuits with several modifications. Their output frequencies reflect the

value of the measured pressure. Consequently, galvanically separated stage, which includes microcontroller, converts the output frequency values of the oscillators onto the digital code values. The embedded microcontroller also calculates non-linear correction of the measured values and temperature calibration at the same time. The output quantity of this part of electronic circuitry is a digital calibrated value of pressure. The most important disadvantage of this method is influence of parasitic capacitance C_{DP} between differential pair of measuring capacitors in sensor, which could make the 555 method unusable. It should have capacity of units of pF. Therefore the oscillators in the circuit do not measure exact value of the measuring capacity.

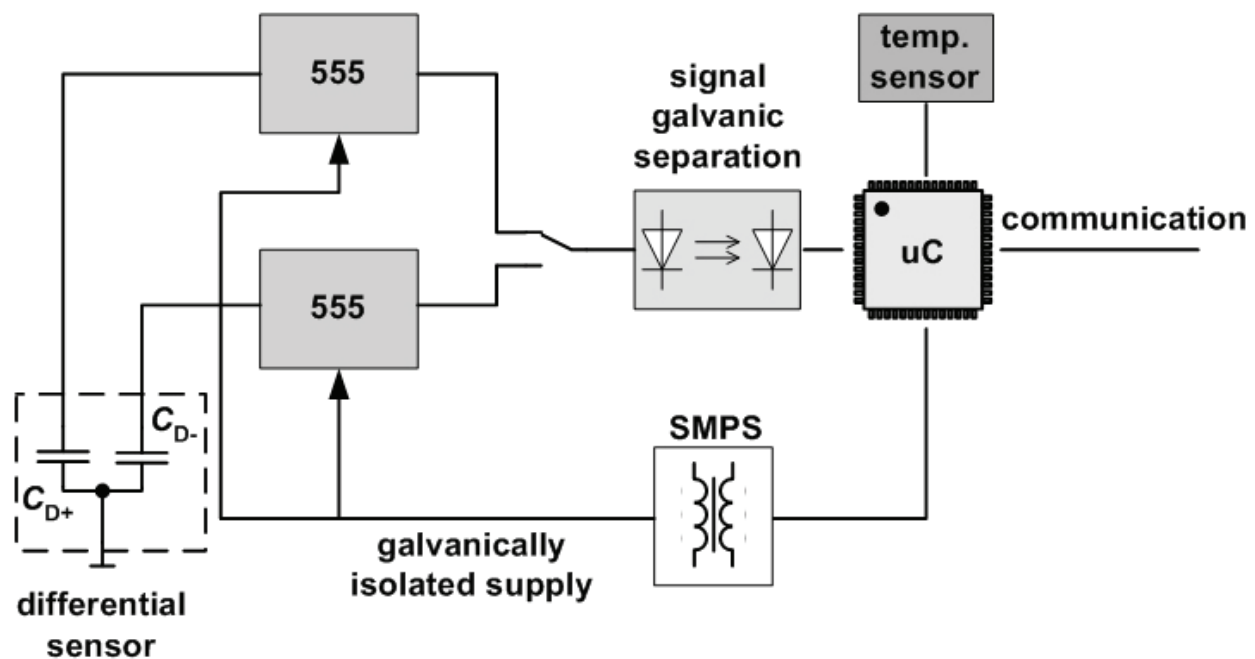

Fig. 4. The block diagram of the measurement method based on 555 timer/counter

Consequently, it is seen, that mentioned methods are relatively simple and effective, they occupy small area of the PCB with low costs. On the other hand they are intended for applications, where is no need for integration of all circuitries as System on Chip (SoC) and they suffer of parasitics influence.

There also exists one method, which is relatively new. This method uses bandpass sigma-delta modulation for pressure measurement (Ong & Wooley 1997), (Brychta, 2005), (Haze et al. 2007). The basic difference between this method and previous two techniques is integration of all functions as SoC. Fig. 5 shows the measurement chain containing a capacitive pressure sensor stage.

This block contains one sensing branch and one reference branch. The phase-locked loop circuit (PLL) provides coherent processing of the input signal in the bandpass sigma-delta modulator. The system works as follows. The pressure influences the ΔC_X capacity and humidity impacts the ΔG_X conductivity of the sensing branch. The $G_X + j\omega C_X$ complex conductance is converted by the bandpass sigma-delta modulator and two digital low pass filters into digital value of the real and the imaginary part. The digital resolution is proportional to the time window of the digital low pass filter.

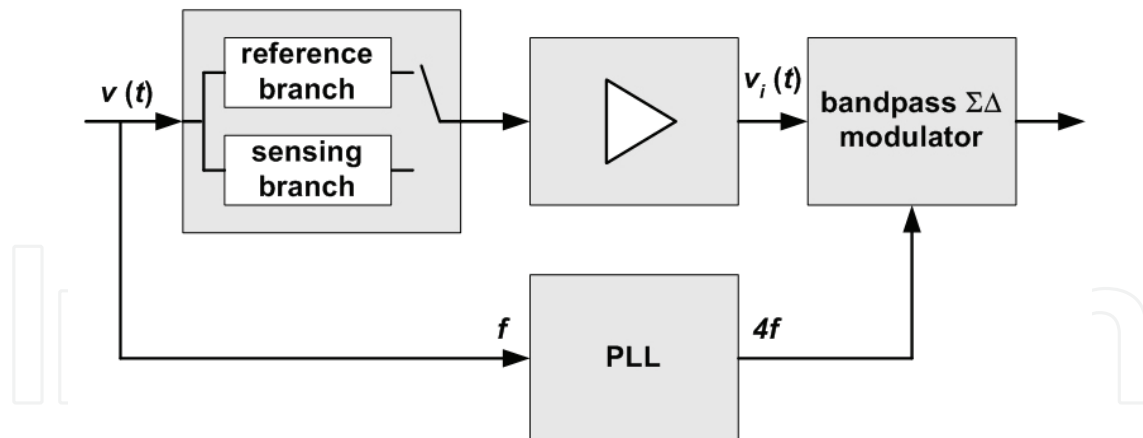

Fig. 5. Pressure sensing using bandpass sigma-delta modulation

The phase shift of the processing block is suppressed by the compensation principle. The difference of the digital values from the sensing branch of the low-pass filter normalized to the value measured in reference branch is expressed by the formula (2). Here measured changes of capacity and resistance changes are

$$\frac{v_1 - v_2}{v_3} = R(j\omega\Delta C_x + \Delta G_x) \quad (2)$$

where v_1 , v_2 and v_3 are voltages measured in each position of the switch, R is resistance in amplifier stage. This principle is more sophisticated than previous methods. It is implemented as SoC with smaller die occupation, low power consumption and higher accuracy of the processed data. On the other hand, because this technique is quite new, some negative aspects could arise during its utilization. Probably it should be narrow area of application, because it is intended for customer defined signals and each change means a lot of changes in whole integrated circuit.

The authors would like to present another approach, which could help to improve the pressure measurement methodology.

2. Charge division approach

Since recent customer demands for low cost, accurate, low power and universal solution of pressure measurement and signal processing, the presented method is designed as SoC. The next reason, why the novel circuitry was designed is parasitic capacity C_{DP} problem, which was discussed above.

The design and simulation of all circuitries were done using OrCAD PSPICE and CADENCE software tool with 035 μm AMIS technology.

2.1 The measurement system

The measurement system utilizes charge division technique on capacitors and subsequent measurement of steady voltage value on parallel combination of capacitors. The principle diagram of measuring circuitry is shown in Fig. 6. This approach requires lower power than other techniques. The main problem of presented technique is very low capacity of output capacitors C_{D+} and C_{D-} . Small value of capacitors (typically 50 to 250 pF) leads to spontaneous losses of charge.

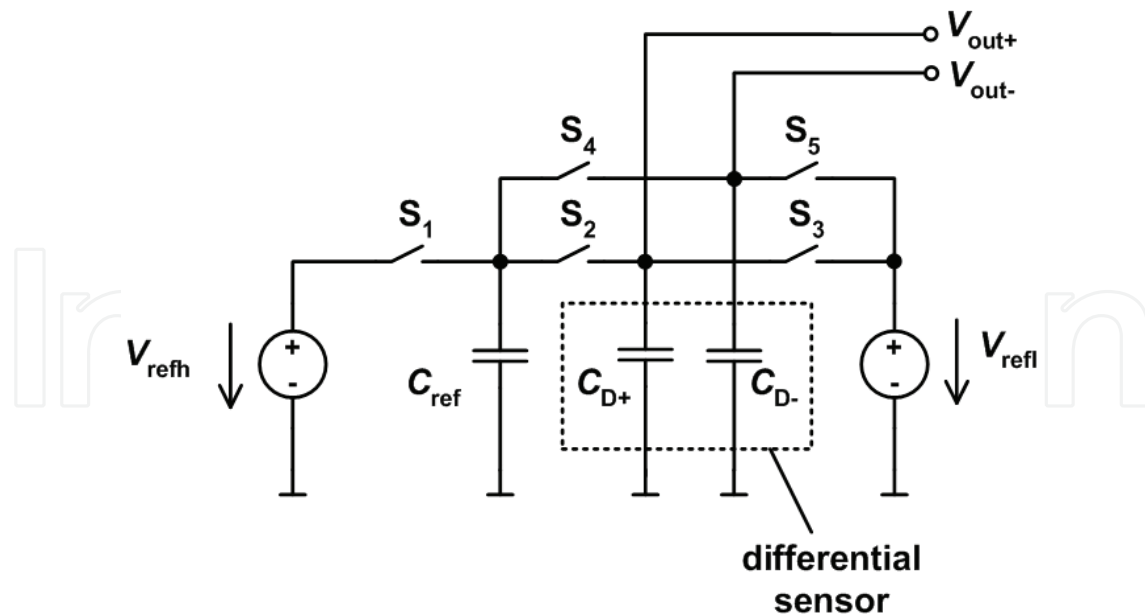

Fig. 6. The proposed charge division method

Many factors act very important role during measurement. The most crucial factors are parasitic leakage currents, charge injection through switches, noise (flicker, thermal) and temperature drift of values.

2.2 The description of measurement process

The whole measurement process is separated into the four phases. The first one is establishing of initial conditions, but only for C_{D+} measurement. Switches S_1 and S_3 are turned on at time t_1 . The referential capacitor C_{ref} is connected to the reference voltage source V_{refh} through the switch S_1 and charged on its voltage. The measured capacitor C_{D+} is connected through switch S_3 to the reference voltage source V_{refl} at the same time.

During the second phase the switches S_1 and S_3 are switched off and switch S_2 is switched on. Therefore the charge transport from the referential capacitor C_{ref} on measured capacitor C_{D+} is allowed. This procedure lasts until the voltages on both capacitors are equal. Now this voltage is sampled by sample and hold circuitry (S/H). The voltage is held for following processing by AD converter.

The third and the last phase are the same like mentioned procedures before with small modification. The capacity C_{D-} is now measured and the working switches are S_1 , S_2 and S_3 . The output of each measurement (on C_{D+} and C_{D-}) is then converted into digital number. These digital outputs are then subtracted, which leads to final digital value of the measured pressure.

2.3 The reference capacitor

The reference capacitor with high quality of dielectric has to be used. Moreover it is problem to implement capacitor with capacitance higher than tens of pF on chip. That is why it is used as external part of the chip. There should be the minimum parasitic leakage currents and the minimum properties changes depending on temperature. The very important parameter is the absolute value of the capacity of the reference capacitor.

The voltage for each differential capacitor is

$$V_{D+} = \frac{Q_{refh} + Q_{D+}}{C_{ref} + C_{D+}} = \frac{V_{refh} C_{ref} + V_{refl} C_{D+}}{C_{ref} + C_{D+}} \quad (3)$$

$$V_{D-} = \frac{Q_{refh} + Q_{D-}}{C_{ref} + C_{D-}} = \frac{V_{refh} C_{ref} + V_{refl} C_{D-}}{C_{ref} + C_{D-}} \quad (4)$$

After merging of both fractions

$$\Delta V = \frac{V_{refh} C_{ref} + V_{refl} C_{D-}}{C_{ref} + C_{D-}} - \frac{V_{refh} C_{ref} + V_{refl} C_{D+}}{C_{ref} + C_{D+}} \quad (5)$$

Fig. 7 shows dependence of voltage variation on reference capacitance and its derivative, which shows the optimal value of referential capacitor with maximum measurement voltage range. The derivative is

$$\frac{d\Delta V}{dC_{ref}} = \frac{V_{refh} (C_{ref} + C_{D-}) + (V_{refh} C_{ref} + V_{refl} C_{D-})}{(C_{ref} + C_{D-})^2} + \frac{V_{refh} (C_{ref} + C_{D+}) + (V_{refh} C_{ref} + V_{refl} C_{D+})}{(C_{ref} + C_{D+})^2} \quad (6)$$

Finally after simplification

$$\frac{d\Delta V}{dC_{ref}} = \frac{2V_{refh} C_{ref} + C_{D-} (V_{refh} + V_{refl})}{(C_{ref} + C_{D-})^2} + \frac{2V_{refh} C_{ref} + C_{D+} (V_{refh} + V_{refl})}{(C_{ref} + C_{D+})^2} \quad (7)$$

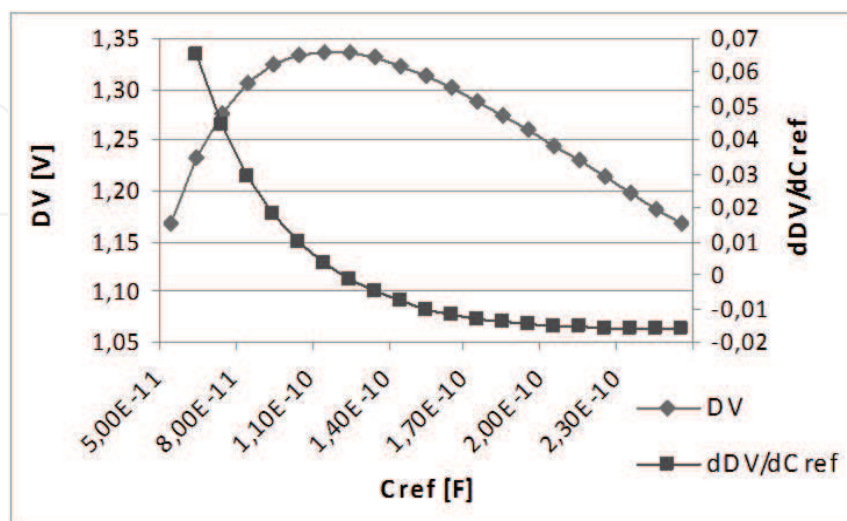

Fig. 7. Dependence of settled voltage after charge division on the value of the reference capacity and its derivative

Now it is simple to find the optimal value of C_{ref} for defined voltage range. For range of measured capacities between 50 pF and 250 pF and reference voltage $U_{refh} = 3$ V the most wide range of final voltage is obtained when reference capacitor is $C_{ref} = 125$ pF. The final voltage range is from 1.33 V to 2.28 V.

The voltage step of one LSB is $V_{LSB} = 14.5$ μ V for desired accuracy of 16 bits. Therefore the maximum uncorrectable error of measured voltage must not exceed 7.25 μ V.

The confirmation of the formulas and the whole principle has been done in OrCAD PSPICE as shown in Fig. 8.

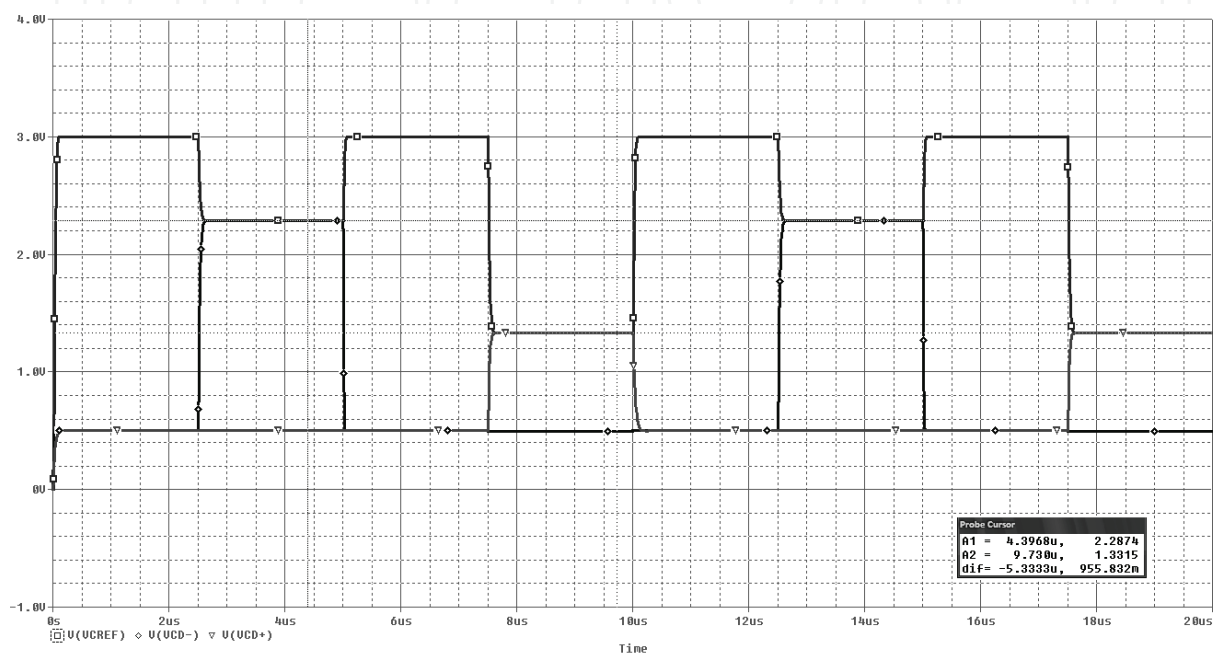

Fig. 8. The charge division method confirmation

The whole measurement process could be divided into two steps. The first includes settling of initial conditions for C_{D+} , measurement and charge division between reference capacitor and C_{D+} . Then this signal is sampled by S/H stage and processed by AD converter. Meanwhile, when the first step is in the middle of its processing period, the second step begins. The only change is that this procedure runs with C_{D-} .

2.4 The errors in proposed system

There arise various errors during measurement process. Some of them are systematic errors (i.e. offset, thermal drift of the switch parameters), which could be eliminated and corrected, for example using correction algorithm or utilizing of some improved circuit techniques (Unbehauen & Cichocki 1989), (Enz & Temes 1996). Fig. 9 shows the dependence of the measured voltage and charging time on the switch dimensions.

It is seen that switch dimensions have significant influence on conversion time and measurement voltage range. Therefore there exists the charge injection influence, too. These errors were corrected by means of dummy switch, utilizing of CMOS switch and fully differential stages (Unbehauen & Cichocki 1989), (Enz & Temes 1996).

There are also uncorrectable accidental errors. The sum of these uncorrectable errors must not exceed half of LSB. The most errors (uncertainty) are caused by the analog switches utilization in proposed measurement system shown in Fig. 6. There are mainly charge injection, parasitic capacitance and leakage current. The first one is charge injection from analog switch into the signal path. The charge is moved onto the switch during switch on phase, while during switch off phase the charge is removed from the switch.

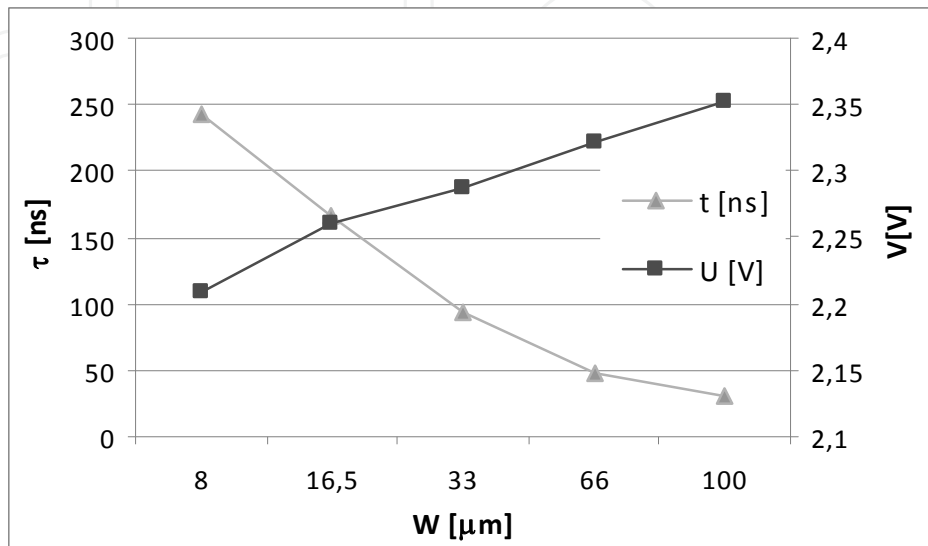

Fig. 9. The problem with switch dimensions

The next problem with real switches is the fact that the value of injected charge hardly depends on the value of the signal voltage. That is why the design shown in Fig. 5 considered this fact. The charge removing from the switches S_1 and S_3 (S_5) is moved on the switch S_2 (S_4). It leads to partial compensation of injected charge. It is clear, that the value of the injected charge depends mainly on dimensions of the analog switch. So it could be supposed, that the value of the injected charge is time independent or depends on time very marginally. Therefore the measurement error by the charge injection could be corrected effectively.

Another error, which is produced by the analog switch, is input parallel parasitic capacity. It is supposed that the error capacity is time independent. This capacity leads to certain capacity offset (about tens of fF) on measured capacitor.

One last important source of measurement error is leakage current of the analog switch between input and ground during switch on and switch off stage. It depends on switch dimensions and it is in order of hundreds of pA. This error is relatively well-known short time independent variable, but its impact leads to gradual discharging of parallel combination of measured and referential capacitor. The conversion time of high resolution and low power ADCs is usually from tens to hundreds of microseconds. The voltage drop on the parallel combination of the capacitors C_{ref} and C_{D} is high, which leads to worthless results of AD conversion. The S/H held the value of measured voltage during the whole measuring process. This voltage must not decrease under presented 0.5 LSB voltage $V_{\text{HLSB}} = 7.25 \mu\text{V}$ of ADC. The same or less drop must be ensured on parallel combination of measured and reference capacitors. There is only short time for acquisition needed, approximately 10^5 shorter than for AD conversion.

2.5 Differential pressure sensor output

The output of differential pressure sensor consists of a pair of variable capacitors as has been presented. Dependence of output capacitors on differential pressure is shown in Fig. 9. The changes of applied pressure are represented by changes of membrane deflection. The basic measurement stage on Fig. 6 was extended by the second part, which serves for measuring of the second capacitor. This modification leads to self compensation of errors caused by parasitic capacities of switches and also partial self compensation of errors produced by leakage currents.

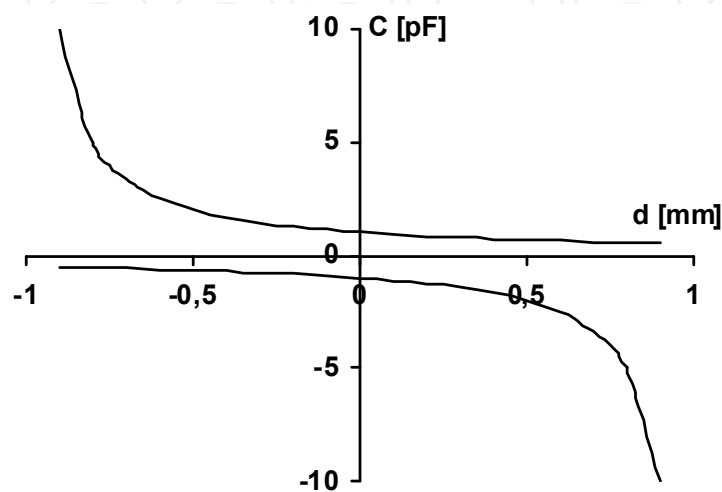

Fig. 9. The dependence of capacitors value on changes of applied pressure

2.6 The design of S/H stage

The input buffer was designed for S/H circuitry because of minimization of input current; otherwise the measured voltage would be influenced. The input of the buffer must have parasitic capacity as small as possible regarding the same problem. The simplified version of the sampling stage without input buffer is shown in Fig. 10. Since it utilizes switched-capacitors approach, the errors caused by this technique were considered and suppressed (Unbehauen & Cichocki 1989), (Enz & Temes 1996).

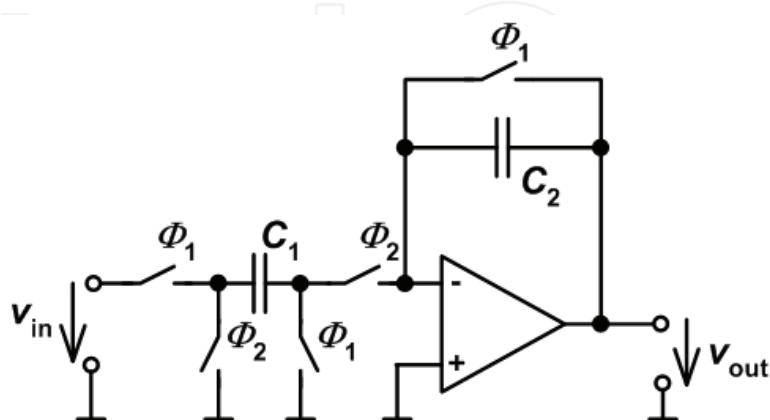

Fig. 10. The sampling stage

Since there was used only one S/H stage for both measured voltages, some additional errors (offset, temperature dependence) are partially suppressed after the processing.

2.7 The design digital part

The modern trend in sensors area tends to utilize a nonvolatile digital memory, which includes information about sensor and calibration values directly on chip. Thanks to this setup each used sensor is uniquely identifiable. Since the calibration values are stored also in the memory, it is possible to calibrate the measured data faster and directly utilizing calibration process. It is clear that due to flexibility requirement and accuracy of the designed device the best solution is placing the chip directly to the sensor.

Even the output of the proposed circuitry is digital output, there is another possibility of the signal processing, which is using of low power microprocessor. The microprocessor could calculate mathematical operations, which are needed for final calibration and its large memory EEPROM or FLASH would be used as storage of calibration data.

2.8 The calibration of the measured values

There are many ways how to calibrate the measured values. The easiest way is a correction of measured values by correction table (Okinori et al. 2003). It is relatively fast method for calibration of nonlinear course of the function, but it is not applicable for calibration, where the high resolution converters above 12-bits are used. It means that the table occupies large part of the memory.

Another fast calibration technique is linear regression (Cohen et al. 2002), but it could be used only for the linear course of the function. The modification based upon the linear regression is a piecewise linear conversion characteristic (Cohen et al. 2002). The accuracy of the calibration depends on number of linear parts. The number of linear parts depends only on character of conversion characteristic therefore individual parts would have not same length. It leads to decrease of memory seriousness and saved place, which would be used for more individual linearized parts. Therefore the most sophisticated solution is an approximation by n -order multinomial. It is possible to linearize the whole conversion characteristic with variable reliability till $R = 99,995\%$. On the other hand this feature is paid by very difficult computing of decimal numbers and power functions.

The polynomial of fifth to eighth order is used for calibration. The basic form of the polynomial is

$$y = a_0 + a_1x + a_2x^2 + \dots + a_nx^n \quad (6)$$

The Lagrange's polynomial is used for calculation of the calibration constants. The Lagrange's polynomial is the lowest order polynomial which goes through specified values. The Lagrange's polynomial can be calculated by

$$\sum_{i=1}^n f(x_i)\lambda_i \quad (7)$$

where

$$\lambda_i = \frac{(x-x_1)(x-x_2)\dots(x-x_{i-1})(x-x_{i+1})\dots(x-x_n)}{(x_i-x_1)(x_i-x_2)\dots(x_i-x_{i-1})(x_i-x_{i+1})\dots(x_i-x_n)} \quad (8)$$

The calibration data are stored in on chip memory.

2.9 The temperature measurement and power supply

The most physical properties of materials depend on temperature variation. That is why the chip design considered this fact. The complete circuitry is proposed as temperature compensated within the range from -40 to 70 °C.

The power supply of the whole SoC is 0 and 3.3 V and it consumes 37 mW.

3. Conclusion and future research

The pressure measurement nowadays tends to processing of the signal from sensor with high accuracy, low cost, low power and high effectivity. Usually the pressure sensor is formed as differential pair of measurement capacitors. There exist several methods of the signal processing, but they suffer from some unwanted effects like parasitic capacitances, inability of integration as SoC, special kind of application etc.

The chapter presents a novel method for pressure processing called charge division. This method is implemented as SoC, so it does not suffer of nonideal effects, which arise using traditional measurement approaches. The switched-capacitors errors are suppressed by means of combination of dummy switches, fully differential circuitries and CDS technique. The main advantages are its complexity, ability to be configured for customers demand, high accuracy and low power of the measurement. The disadvantage is mainly the usage of several external parts, which cannot be implemented on the chip.

The SoC is already finished and it will be fabricated. The testing and redesign will proceed in future towards higher integration a lower power consumption.

4. Acknowledgements

The research has been supported by the Czech Ministry of Education within the framework of the Research Program MSM0021630503 MIKROSYN and by the Czech Science Foundation under the 102/08/1116 Methods of Signal Digitizing for Advanced Sensors Project.

5. References

- Brychta, M. Measure Capacitive Sensors with a Sigma-Delta Modulator, *Electronic design online journal*, April 2005, <http://electronicdesign.com/Articles/Index.cfm?AD=1&AD=1&ArticleID=10185>
- Burczyk, D., Dannhauer, W., Nurnberger, R. Differential pressure sensor and method of differential pressure measurement. US Patent 6581469, 2002
- Cohen, J., West, G., S., Cohen, P., Aiken, L. *Applied Multiple Regression/Correlation Analysis for the Behavioral Sciences* Lawrence Erlbaum Assoc Inc., 2002, ISBN 9780805822236
- Enz, CH., C. & Temes, G., C. *Circuit Techniques for Reducing the Effects of Op-Amp Imperfections: Autozeroing, Correlated Double Sampling, and Chopper Stabilization. Proceedings of the IEEE*, Vol. 84, No. 11, (November 1996), 1584 - 1614, ISSN 0018-9219
- Haze, J., Vrba, R., Fucik, L., Forejtek, J., Zavoral, P., Pavlik, M. & Michaeli, L. *BandPass Sigma-Delta Modulator for Capacitive Pressure Sensor*. Proceedings of IMTC 2007 Conference. Warsaw, Poland, ISBN 1-4244-0589-0

- He, F.; Huang, Q.A. & Qin, M. A silicon directly bonded capacitive absolute pressure sensor. *IEEE Sensors and Actuators A*. Vol. 135, Issue 2, (November 2007), 507 - 514, ISSN 0924-4247
- Chavan, A. & Wise, K.D. A batch-processed vacuum-sealed capacitive pressure sensor, *IEEE Journal of Microelectromechanical Systems*, Vol. 10, No. 4, (Dec. 2001), 580 - 588, ISSN 1057-7157
- Lee, Y. S. & Wise, K. D. A batch-fabricated silicon capacitive pressure transducer with low temperature sensitivity. *IEEE Transactions on Electron Devices*, Vol. 29, Issue 1, (January 1982), 42 - 48, ISSN 0018-9383
- Ong, A., K. & Wooley, B., A. A Two-Path Bandpass SD Modulátor for Digital IF Extraction at 20 MHz, *IEEE Journal of Solid-State Circuits*, Vol. 32, No. 12, Dec., 1997, ISSN 0018-9200
- Okinori, T., Shigeyasu, N., Akihiko, N. *Correction table generation method and method of controlling correction table generation apparatus*. US Patent 6945626, 2003
- Pavlik, M., Haze, J., Vrba, R. & Sveda, M. *Smart Differential Pressure Sensor*. Proceedings of 4th International Conference on Informatics in Control, Automation and Robotics. Angers, France, 244 - 248, INSTICC, ISBN 978-972-8865-87-0
- Unbehauen, R. & Cichocki, A. *MOS Switched-Capacitor and Continuous-Time Integrated Circuits and Systems*. Springer-Verlag, 1989, ISBN 3-540-50599-7, Berlin
- Whytock, P. Capacitance and Impedance Converters - A High-Precision First. *Electronic design online journal*, April 2005, <http://europe.elecdesign.com/Articles/ArticleID/10238/10238.html>
- Pavlik, M., Vrba, R., Kuban, M. Switched Current Flash Analog to Digital Converter. In *Third International Conference on Systems*. 2008. p. 341 - 344. ISBN 978-0-7695-3105-2

IntechOpen



Robotics Automation and Control

Edited by Pavla Pecherkova, Miroslav Flidr and Jindrich Dunik

ISBN 978-953-7619-18-3

Hard cover, 494 pages

Publisher InTech

Published online 01, October, 2008

Published in print edition October, 2008

This book was conceived as a gathering place of new ideas from academia, industry, research and practice in the fields of robotics, automation and control. The aim of the book was to point out interactions among various fields of interests in spite of diversity and narrow specializations which prevail in the current research. The common denominator of all included chapters appears to be a synergy of various specializations. This synergy yields deeper understanding of the treated problems. Each new approach applied to a particular problem can enrich and inspire improvements of already established approaches to the problem.

How to reference

In order to correctly reference this scholarly work, feel free to copy and paste the following:

Michal Pavlik, Jiri Haze and Radimir Vrba (2008). New Trends in Evaluation of the Sensors Output, Robotics Automation and Control, Pavla Pecherkova, Miroslav Flidr and Jindrich Dunik (Ed.), ISBN: 978-953-7619-18-3, InTech, Available from:

http://www.intechopen.com/books/robotics_automation_and_control/new_trends_in_evaluation_of_the_sensors_output

INTECH

open science | open minds

InTech Europe

University Campus STeP Ri
Slavka Krautzeka 83/A
51000 Rijeka, Croatia
Phone: +385 (51) 770 447
Fax: +385 (51) 686 166
www.intechopen.com

InTech China

Unit 405, Office Block, Hotel Equatorial Shanghai
No.65, Yan An Road (West), Shanghai, 200040, China
中国上海市延安西路65号上海国际贵都大饭店办公楼405单元
Phone: +86-21-62489820
Fax: +86-21-62489821

© 2008 The Author(s). Licensee IntechOpen. This chapter is distributed under the terms of the [Creative Commons Attribution-NonCommercial-ShareAlike-3.0 License](https://creativecommons.org/licenses/by-nc-sa/3.0/), which permits use, distribution and reproduction for non-commercial purposes, provided the original is properly cited and derivative works building on this content are distributed under the same license.

IntechOpen

IntechOpen