

We are IntechOpen, the world's leading publisher of Open Access books Built by scientists, for scientists

4,800

Open access books available

122,000

International authors and editors

135M

Downloads

Our authors are among the

154

Countries delivered to

TOP 1%

most cited scientists

12.2%

Contributors from top 500 universities



WEB OF SCIENCE™

Selection of our books indexed in the Book Citation Index
in Web of Science™ Core Collection (BKCI)

Interested in publishing with us?
Contact book.department@intechopen.com

Numbers displayed above are based on latest data collected.

For more information visit www.intechopen.com



Time-Scaling of SISO and MIMO Discrete-Time Systems

Bogdan Grzywacz
Szczecin University of Technology
Poland

1. Introduction

Finally the paper deals with the solution of the following problem:

Let signals $y_1(iT), \dots, y_q(iT)$ (elements of output vector $\mathbf{y}(iT)$) be responses of MIMO discrete-time system to the input signals $u_1(iT), \dots, u_q(iT)$ (elements of input vector $\mathbf{u}(iT)$). Determine discrete-time excitations u_{A1}, \dots, u_{Aq} (elements of vector \mathbf{u}_A) scaling the system responses to the required forms $y_1(iA^{-1}T), \dots, y_q(iA^{-1}T)$, where A is positive number called "time scale coefficient", T -reference sample time, i -sample number.

If $A > 1$, then system responses are speeded up comparing them to reference responses $y_1(iT), \dots, y_q(iT)$. Putting $0 < A < 1$ one slows the responses down. The perfect scaling of system makes, that moments of appearances of consecutive amplitudes belonging to the reference responses $y_1(iT), \dots, y_q(iT)$ are "controlled" according to value of A . The scaling of system responses yields transparent representations in time and frequency domains. Thus, the time-scaling seems to be useful tool for speeding the system responses up, or slowing them down, if forms of reference responses satisfy technical needs. Let us note, that perfect scaling of stable system conserves its stability.

The methods presented in current Chapter can be applied for time-scaling of responses of continuous-time systems on the basis of respective discrete-time models. Thus, the considered methods can be treated as alternative solutions to those for time-scaling of continuous-time systems (Durnas & Grzywacz, 2001; Durnas & Grzywacz, 2002; Grzywacz, 2006). Of course, there are other ways of application of time-scaling techniques, like those, for example, presented in (Moya et al., 2002; Respondek & Pogromsky, 2004), where problem of synthesis of controllers and observers for certain classes of non-linear plants has been solved. In current Chapter we do not deal with time-scaling in this meaning.

2. The idea of method for SISO systems

2.1 Slowing the system response down

Let us consider the class of SISO nonlinear, discrete-time systems of order n defined for sample time T by state equations system:

Source: New Approaches in Automation and Robotics, Book edited by: Harald Aschemann, ISBN 978-3-902613-26-4, pp. 392, May 2008, I-Tech Education and Publishing, Vienna, Austria

$$\begin{aligned}
 x_1(i+1) &= x_2(i) \\
 x_2(i+1) &= x_3(i) \\
 &\dots\dots\dots
 \end{aligned}
 \tag{1}$$

$$x_n(i+1) = f [x_1(i), x_2(i), \dots, x_{n-1}(i)] + u(i)$$

$$y(i) = F [b_0 x_1(i) + b_1 x_2(i) + \dots + b_{n-1} x_n(i)]$$

where $x_1(i), x_2(i), \dots, x_n(i)$ - components of state vector $x(i)$, f and F represent static nonlinear functions, $u(i)$ - system input, $y(i)$ - system output, i - sample number. In particular case, if $F [.] = b_0 x_1(i) + b_1 x_2(i) + \dots + b_{n-1} x_n(i)$ and $f(.) = - (a_0 x_1(i) + a_1 x_2(i) + \dots + a_{n-1} x_n(i))$, the system (1) becomes to linear one given by transfer function:

$$G(z) = \frac{b_{n-1}z^{n-1} + \dots + b_1z + b_0}{z^n + a_{n-1}z^{n-1} \dots + a_1z + a_0} \tag{2}$$

The simplified scheme of system (1) is shown in Fig.1. In order to slow system response down α times (α positive integer number), we can join the element z^{-k} , where $k=(\alpha-1)$, to the all single unit delay elements z^{-1} belonging to the system shown in Fig. 1 (i.e. each z^{-1} in "primary" structure is replaced by $z^{-(k+1)}$). Additionally, if we substitute the reference excitation $u(iT)$ with the new one $u(iT')$, where $T' = \alpha T$, then both above modifications change the system response to the form $y(iT')$. This means, that form of reference response $y(iT)$ is conserved perfectly. If system (1) represents real plant or its model which is used to calculation of signal for plant control, then "internal" modification of structure in Fig. 1 cannot be done. Thus, the time-scaling of system in Fig. 1 has to be done by suitable forming of its excitation $u(i)$, without modification of its internal structure.

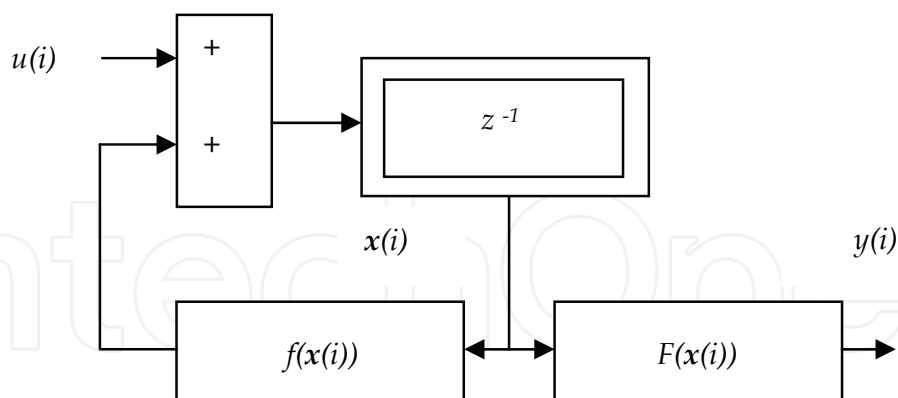

Fig. 1. The simplified scheme of system (1): z^{-1} - chain of unit delay elements, $x(i)$ -state vector with components representing outputs of single delay elements, F and f - static nonlinear functions, u -input, y - output.

To solve the task of scaling one can try to do reconfiguration of modified structure like in Fig. 1 (that containing elements $z^{-(k+1)}$ instead of z^{-1}) to the structure shown in Fig. 2, where SYSTEM represents "primary" structure shown in Fig. 1 (from before any modification). The relevant calculations allow to express the operation realized by "INPUT" corrector in the form:

$$G_z(z) = \frac{b_{n-1}z^{nk+n-k-1} + b_{n-2}z^{nk+n-2k-2} + \dots + b_1z^{k+1} + b_0}{b_0z^{nk} + b_1z^{nk+1} + \dots + b_{n-2}z^{nk+n-2} + b_{n-1}z^{nk+n-1}} \quad (3)$$

The output signal of „FEEDBACK” corrector is formed as it follows: components of state vector $x(i)$ are passed through the transfer function $(G_z(z))^{-1}$. This creates auxiliary signals $x'_1(z) = [(G_z(z))^{-1} x_1(z)]$, ..., $x'_n(z) = [(G_z(z))^{-1} x_n(z)]$. Then, on the basis of signals $x'_1(i)$, ..., $x'_n(i)$ one can create signal $u_f(i)$ according to formula:

$$u_f(i) = f[x'_1(i-nk), x'_2(i-(n-1)k), \dots, x'_n(i-k)] \quad (4)$$

Note, that operation (4) processes the delayed signals $x'_1(i)$, ..., $x'_n(i)$. Next signal $u_f(i)$ has to be passed through the transmittance $G_z(z)$. Its output signal is $u_{fG}(i)$. Finally, the output signal $U_f(i)$ of „FEEDBACK” corrector which “fits” for scheme shown in Fig. 2. is composed using expression:

$$U_f(i) = u_{fG}(i) - f[x_1(i), x_2(i), \dots, x_{n-1}(i)] \quad (5)$$

The input signal of structure shown in Fig.2 ought to be $u(iT')$, which means, that one has to repeat the form of reference input signal of system shown in Fig. 1 (i.e. $u(iT)$ for $A^{-1} = \alpha = 1$), however the consecutive amplitudes of signal $u(iT')$ are changed now at moments (iT') . Let us note, that both systems (those in Fig. 1 and Fig. 2) operate with the same sample time T . If order of denominator of $G_z(z)$ is higher than order of nominator, then we can use function $G'_z(z) = (z^d G(z))$ instead of $G(z)$, where d represents the difference between denominator order and nominator order. This “deviation” does not affect the form of output signal. It is merely shifted forwards d samples T .

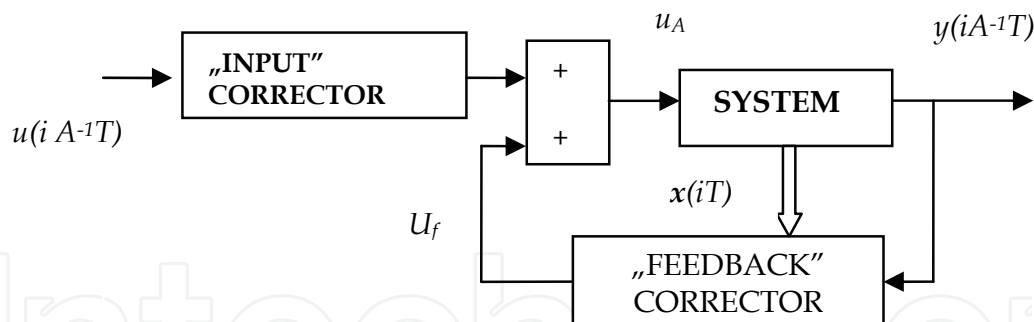

Fig. 2. The time-scaling of linear and nonlinear SISO systems: $u(iA^{-1}T)$ - scaled reference excitation, u_A - system input scaling its response, $y(iA^{-1}T)$ - scaled reference response $y(iT)$, $x(iT)$ - system state vector.

Example A. Let us consider the second order system (6) belonging to class (1):

$$\begin{aligned} x_1(i+1) &= x_2(i) \\ x_2(i+1) &= f[x_1(i), x_2(i)] + u(i) \\ y(i) &= F[b_0 x_1(i) + b_1 x_2(i)] \end{aligned} \quad (6)$$

where $f(.) = -0.72 x_1(i) + 0.5 (x_2(i))^3$, $F(.) = |2x_1(i) + 5x_2(i)|$.

The response of system (6) to signal $u(i) = 1(i)$ for $T = 1s$ is shown in Fig. 3. Let us assume, that form of that response fulfils the technical needs, however it is "too speedy" and should be slowed down 2 times. Hence $A=0.5$, $n=2$, $\alpha=2$, $k=1$, $b_0=2$, $b_1=5$. Putting $k=1$, $n=2$ to (3) one obtains the INPUT corrector (see Fig. 2) in the form:

$$G_z(z) = \frac{5z^2 + 2}{5z^3 + 2z^2} \quad (7)$$

To design FEEDBACK corrector we have to use $(G_z(z))^{-1}$. Inversion of $G(z)$ yields transfer function with order of numerator higher than order of denominator. However, this is only the apparent difficulty. Instead of $G(z)$ we can put the invertible transfer functions $G'_z(z) = [z G_z(z)]$ with identical orders of nominator and denominator to the FEEDBACK and INPUT correctors. This "deviation" does not affect the form of output signal. It is merely shifted forward one sample time period T .

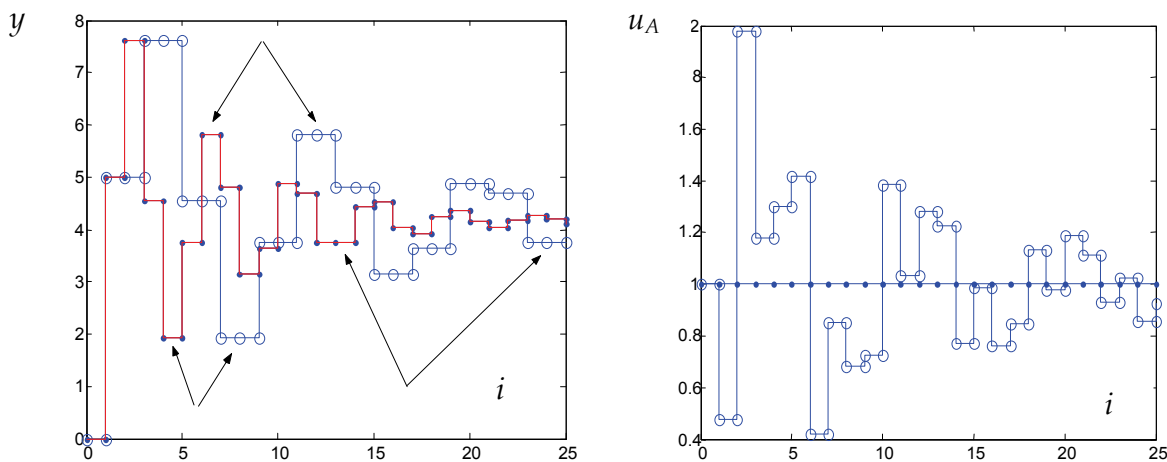

Fig. 3. **Left position:** the reference response of system (6) to signal $u(i) = 1(i)$ – curve distinguished by "." – and response of system (6) obtained as output signal of structure in Fig. 2 – curve distinguished by "o". Note, that consecutive amplitudes of both responses are identical (compare chosen referring amplitudes indicated by arrows). **Right position:** reference input signal $u(i) = 1(i)$ and input signal $u_A(i)$ of system (6) when included to structure in Fig. 2 as SYSTEM.

The FEEDBACK corrector (see Fig. 2) for system (6) and assumed values of A , k , n can be defined by means of $G'_z(z) = [z G_z(z)]$ and nonlinear functions

$$u_f(i) = f[x'_1(i-2), x'_2(i-1)] = -0.72 x'_1(i-2) + 0.5(x'_2(i-1))^3$$

$$U_f(i) = u_{fG}(i) - f[x_1(i), x_2(i)] \quad (8)$$

where signal $u_{fG}(i)$ is generated by passing of signal $u_f(i)$ through the transfer function $G'_z(z)$. The simulations carried out for structure like in Fig. 2 and data referring to current example yield results shown in Fig. 3. We can observe, that described above algorithm allows to design the INPUT and FEEDBACK correctors which guarantee the perfect result of scaling.

2.2 Speeding the system response up

Let model (1) be used for calculation of system input signal which speeds its reference response up A times (A - positive integer). If primary model (1) as well as system excitations are defined for sample time T , then one cannot speed its response up without shortening of sample time. We can treat, that operator z^{-1} associated with sample time T can be expressed as $z^{-1} = Z^{-A}$, where Z^{-1} refers to delay $T' = A^{-1}T$. Thus, we can imagine, that each unit delay z^{-1} of "primary" structure in Fig. 1 is substituted by Z^{-A} . The described transformations of primary model (1) make, that modified structure operates with sample time T' , although system model (1) has been defined for sample time T . Now, if we remove $k = (A-1)$ elements Z^{-1} from each single "cell" $z^{-1} = Z^{-A}$, then we obtain structure like in Fig. 1, where operators z^{-1} are replaced with Z^{-1} . If we put scaled signal $u(iT')$ to input of that modified structure (instead of primary $u(iT)$), then response of modified system will be speeded up A -times and form of reference output (from before the described modification) will be conserved. However, dealing with discrete-time models of real plants used for calculations of signals for control purposes we cannot manipulate "inside" of structure modeling the plant and all manipulations ought to be done "externally" in relation to plant model "interior".

To solve the problem of scaling by synthesis of suitable input signal we can try to do reconfiguration of modified structure like in Fig.1 (that containing Z^{-1} instead of z^{-1}) to the structure shown in Fig. 2, where SYSTEM represents the "primary" structure shown in Fig.1 from before modifications described above. Like in case taken into account in Section 2.1 the current task can be solved similarly, due to equivalent transformations of modified structure aimed at separation of its subsystem, which obtains the form of "primary" system, that shown in Fig. 1, with unit delays z^{-1} replaced by chain of A single delays Z^{-1} . The equivalent transformations are based on property $Z^{-1} = z^{-1} Z^k$, where $k = (A-1)$. The calculations allow to define the following operation realized by "INPUT" corrector:

$$G_z(Z) = \frac{b_0 Z^{nk} Z^0 + b_1 Z^{(n-1)k} Z^{2A} + \dots + b_{n-1} Z^k Z^{2A(n-1)}}{b_0 + b_1 Z^{k+1} + \dots + b_{n-1} Z^{(n-1)(k+1)}} \quad (9)$$

The output signal of „FEEDBACK“ corrector can be generated as it follows: the shifted forward components of state vector, those corresponding to sample time T , i.e. $x_1(i+nk)$, $x_2(i+(n-1)k), \dots, x_n(i+k)$ should be passed through the transfer function $(G_z(Z))^{-1}$. This operation yields the signals $x'_1(i+nk)$, $x'_2(i+(n-1)k), \dots, x'_n(i+k)$ respectively. Using these auxiliary signals one can form signal $u_f(i)$:

$$u_f(i) = f[x'_1(i+nk), x'_2(i+(n-1)k), \dots, x'_n(i+k)] \quad (10)$$

Note, that shifted forwards components of vector x are available, because they are generated as output signals of "former" delay elements Z^{-1} creating chain of delays used for assembling the model (1) or can be generated by delaying of "former" state variables associated with model (1). Next signal $u_f(i)$ has to be passed through the transfer function $G_z(Z)$. Let output signal of $G_z(Z)$ be denoted by $u_{fG}(i)$. Finally, the output signal $U_f(i)$ of "FEEDBACK" corrector (see Fig. 2) is composed using formula :

$$U_f(i) = u_{fG}(i) - f[x_1(i), x_2(i), \dots, x_{n-1}(i)] \quad (11)$$

The described rules allow to scale exactly the output y , if SYSTEM “pretends” operation with sample time T (because of substitution $z^{-1} = Z^{-A}$) and its real sample time is $T'=(A^{-1}T)$. It is obvious, that one cannot speed up the reference output $y(iT)$, conserving its consecutive amplitudes, if system sample time is still T . However, dependently of A , we can remove every second, or every third, etc. amplitudes from reference sequence $y(iT)$ and consecutive remaining amplitudes generate with sample time T . This way can be treated as simplified one for speeding the SYSTEM response up (some amplitudes of reference response are not repeated), if sample time T of primary SYSTEM cannot be shortened. To obtain simplified result of speeding of reference response up we can use signal u_A (Fig. 2) which is generated exactly like it was described above for SYSTEM operating with sample time T' . However, signal u_A determined for T' should be passed through the “ZOH” (zero order hold) element defined for sample time T . Then output signal of “ZOH” operation should be put as excitation to input of “primary” SYSTEM, i.e. that operating with sample time T . It means, that SYSTEM operating with T' in structure like in Fig. 2 should be treated now as calculation model of real primary SYSTEM operating with the sample time T .

Example B. Let us consider once more the second order system (6). The reference response of system (6) to signal $u(i) = 1(i)$ for $T=1$ has been shown in Fig. 3. Let us assume, that form of considered response fulfills the technical needs, however it is “too slow” and should be speeded up 2 times. Hence $A=2$, $n=2$, $k=1$, $b_0=2$, $b_1=5$. Putting $k=1$, $n=2$ to (9) one obtains the INPUT corrector (see Fig. 2) in the form:

$$G_z(Z) = \frac{5Z^3 + 2Z}{5Z^2 + 2} \quad (12)$$

To avoid of processing of transfer function with higher order of nominator than order of denominator we can use transfer function $G_z'(Z) = [Z^{-1} G_z(Z)]$ with identical orders of nominator and denominator. This “deviation” does not affect the form of time-scaled output signal. It is merely shifted backwards one sample period T' . The FEEDBACK corrector (Fig. 2) for system (6) and assumed values A,k,n can be defined by means of $G_z'(Z)=[Z^{-1} G_z(Z)]$ and nonlinear functions:

$$u_f(i) = f[x'_1(i+2), x'_2(i+1)] = -0.72 x'_1(i+2) + 0.5(x'_2(i+1))^3$$

$$U_f(i) = u_{fG}(i) - f[x_1(i), x_2(i)] \quad (13)$$

where signal $u_{fG}(i)$ is generated by passing the signal $u_f(i)$ through the transfer function $G_z'(Z)$. The scheme of system for speeding the response of system (6) is shown in Fig. 4. The exemplary simulation results are shown in Fig. 5.

The result of simplified scaling of system (6) is shown in Fig. 5 as well (see lowest position). This result has been obtained by passing of signal u_A generated in system shown in Fig. 4 through the “ZOH” operation defined for primary sample time T . After that, the output of “ZOH” operation has been used as excitation of primary SYSTEM (6), that defined for sample time T .

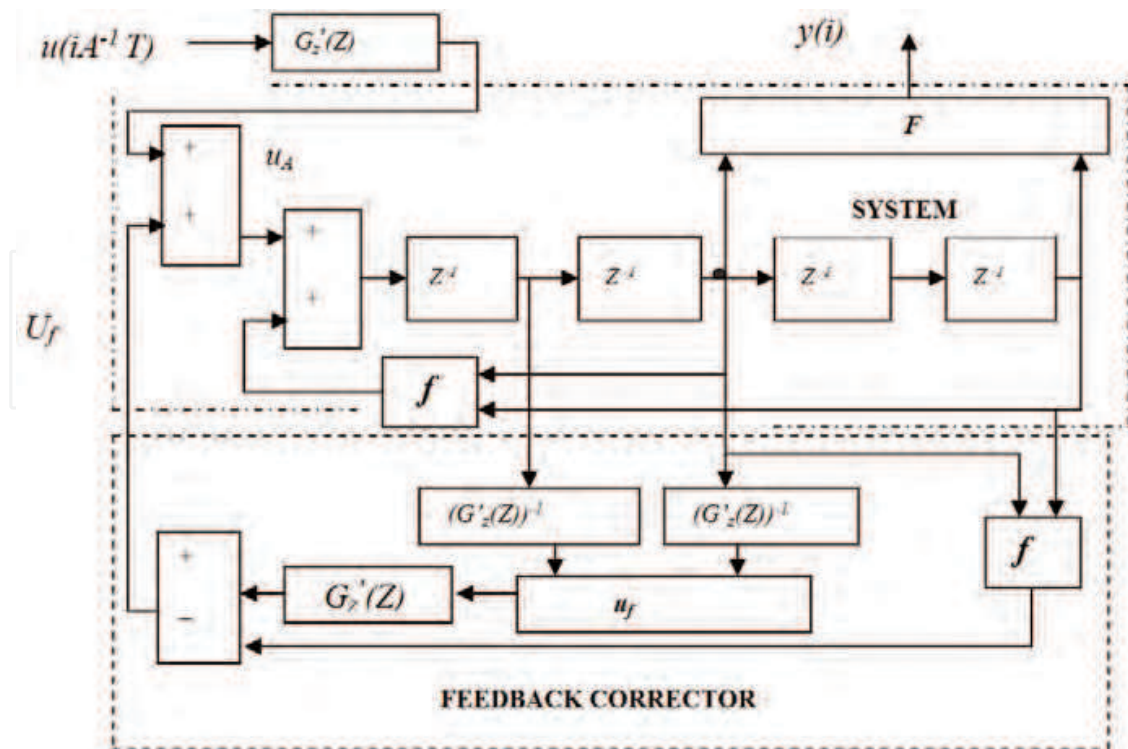

Fig. 4. The scaling of system (6) according to Fig. 2 and matter of *Example B*. Note, that primary delays T (for z^{-1}) are substituted with the two delays $T' = 0.5 T$, where T' refers to operator Z^{-1} .

2.3 Generalization

The considerations in previous Sections have been carried out for A being fraction with numerator equal to one (for slowing the response down) or A being integer number (for speeding the response up). The identical reasoning can be repeated, if each operator of primary unit delay z^{-1} in system shown in Fig.1 is substituted with the chain of α operators Z^{-1} associated with delay $T' = T/\alpha$ and next each single unit delay $z^{-1} = Z^{-\alpha}$ is substituted with $(Z^{-\alpha} Z^{\beta})$ for slowing the response or with $(Z^{-\alpha} Z^{\beta})$, where $\beta < \alpha$, for speeding the response. All farther transformations aimed at separation of primary system structure (from before scaling) can be done exactly like it has been described in previous Sections. Thus, it is easy way of scaling if one needs to slow the response down $[(\alpha + \beta)/\alpha]$ times or speed it up $[\alpha/(\alpha - \beta)]$ times. Of course, the obtained final structure (like in Fig. 2) has to be supplied with scaled reference excitation u .

Looking for other possibilities of scaling of discrete-time systems we can adjust algorithms for scaling of continuous-time systems (Durnas & Grzywacz, 2001; Durnas & Grzywacz, 2002; Grzywacz, 2006). The system (1) can be or can be treated as it would be the discrete-time model of certain continuous-time system. So, one can determine the continuous-time model associated with system (1). Then obtained model can be scaled like continuous-time system. Finally, the respective scheme for scaling of continuous-time model can be transformed back into discrete-time scheme. We must honestly admit, that scaling via continuous-time representation does not guarantee the same consecutive amplitudes of discrete-time output signals for variety of values of A . Nevertheless, we can treat this way as determination of approximate solution.

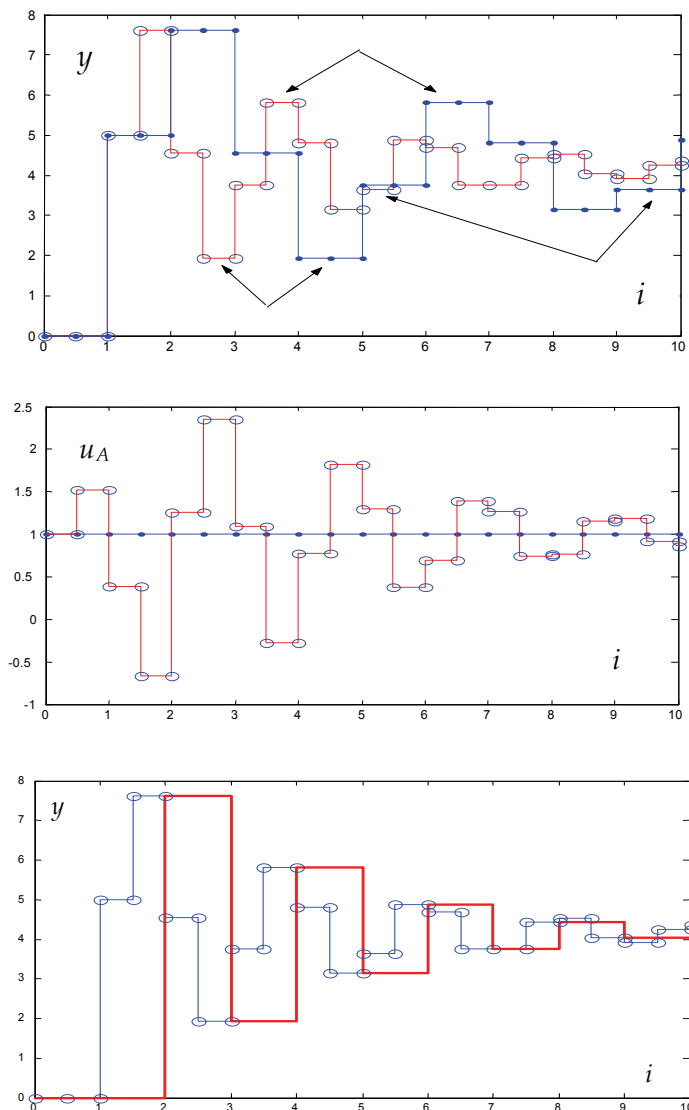

Fig. 5. **Upper figure:** the reference response of system (6) to signal $u(i)=1(i)$ - curve distinguished by "." - and the speeded response of system (6) obtained as output signal of structure in Fig. 4 - curve distinguished by "o". Note, that consecutive amplitudes of both responses are identical (compare chosen referring amplitudes indicated by arrows). **Below:** reference input $u(i)=1(i)$ and input signal $u_A(i)$ of system (6) when included to structure in Fig. 4 (or in Fig. 2) as SYSTEM. **The lowest position:** the speeded response of system (6) obtained as output of structure in Fig. 4 - curve distinguished by "o" - and simplified result of scaling with sample time T - heavy line. Note, that every second amplitude of perfectly scaled output $y(iT)$ is equal to respective amplitude of simplified result of scaling for sample time T .

3. Time-scaling of MIMO systems

Let us assume, that MIMO system can be modelled by "V" structure (Chen, 1983) shown in Fig. 6, where V_{mj} are linear or nonlinear operations processing the input or output signals respectively. To scale the "V" structure one has to replace its SISO elements V_{mj} (Fig. 6) by

respective SISO structures shown in Fig. 2 (where V_{mj} has to be treated as "SYSTEM" - see Fig. 2 - and elements V_{Imj} , V_{Fmj} represent operations of associated INPUT corrector and FEEDBACK one respectively). After the above modification of primary "V" structure one can arrange the set of equivalent scheme transformations aimed at separation of primary "V" structure. This goal can be achieved and signals u_{A1} , u_{A2} scaling the outputs y_1 , y_2 can be generated by equipping the system with external correction loops. It means, that internal structure of system is not affected. If the reference signals $u_1(iT)$, $u_2(iT)$ exciting the system (see Fig. 6, Fig.7) are substituted with signals u_{A1} , u_{A2} :

$$\begin{aligned} u_{A1} &= V_{I11}(u_1(iA^{-1}T) + V_{A21}(y_2)) + V_{F11}(x_{11}, y_1) - V_{21}(y_2) \\ u_{A2} &= V_{I22}(u_2(iA^{-1}T) + V_{A12}(y_1)) + V_{F22}(x_{22}, y_2) - V_{12}(y_1) \end{aligned} \quad (14)$$

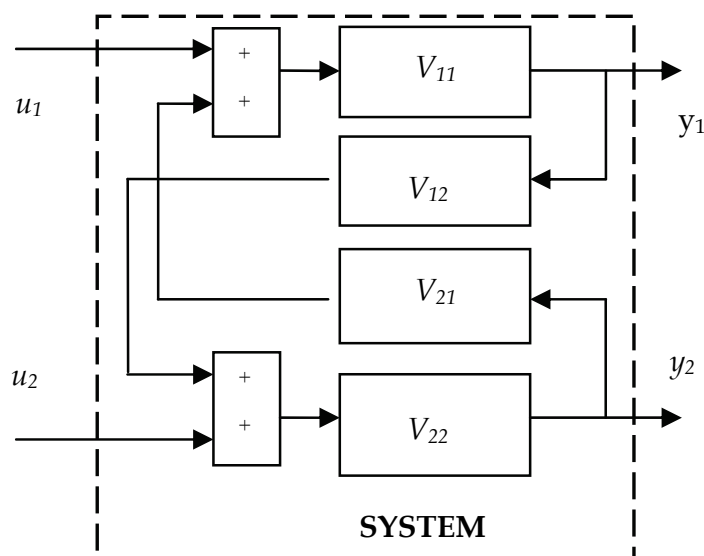

Fig. 6. The exemplary V-structure for 2 inputs and 2 outputs.

then system responses to these signals will be $y_1(iT')$ and $y_2(iT')$, instead of $y_1(iT)$ and $y_2(iT)$ from before correction. Thus, the system output signals are scaled perfectly. The operations realised by INPUT correctors associated with elements V_{11} and V_{22} (see Fig. 2) have been denoted in (14) by V_{I11} , V_{I22} . The operations realised by FEEDBACK correctors associated with V_{11} and V_{22} have been denoted by V_{F11} , V_{F22} . The operations responsible for interaction (Fig. 6) are denoted by V_{21} , V_{12} . The time-scaled interaction operations V_{21} and V_{12} are denoted by V_{A21} and V_{A12} (if, for example, $r_1(iT) = V_{21}(y_2(iT))$, then $r_1(iT') = V_{A21}(y_2(iT'))$). Finally, the state vectors chosen for V_{11} and V_{22} are denoted by $x_{11}(i)$, $x_{22}(i)$. If necessary, one can generalise (14) to the form covering the required number of inputs and outputs:

$$u_{Am} = V_{I_{mm}}(u_m(iA^{-1}T) + \sum_{\substack{j=1 \\ j \neq m}}^q V_{A_{jm}}(y_j)) + V_{F_{mm}}(x_{mm}, y_m) - \sum_{\substack{j=1 \\ j \neq m}}^q V_{jm}(y_j), \quad m=1, \dots, q, \quad j=1, \dots, q \quad (15)$$

The generalization (15) is applicable, if SISO components of “V” model of MIMO system can be scaled in structure shown in Fig. 2. This means, that presented rules of scaling for SISO systems can be useful for scaling of MIMO systems.

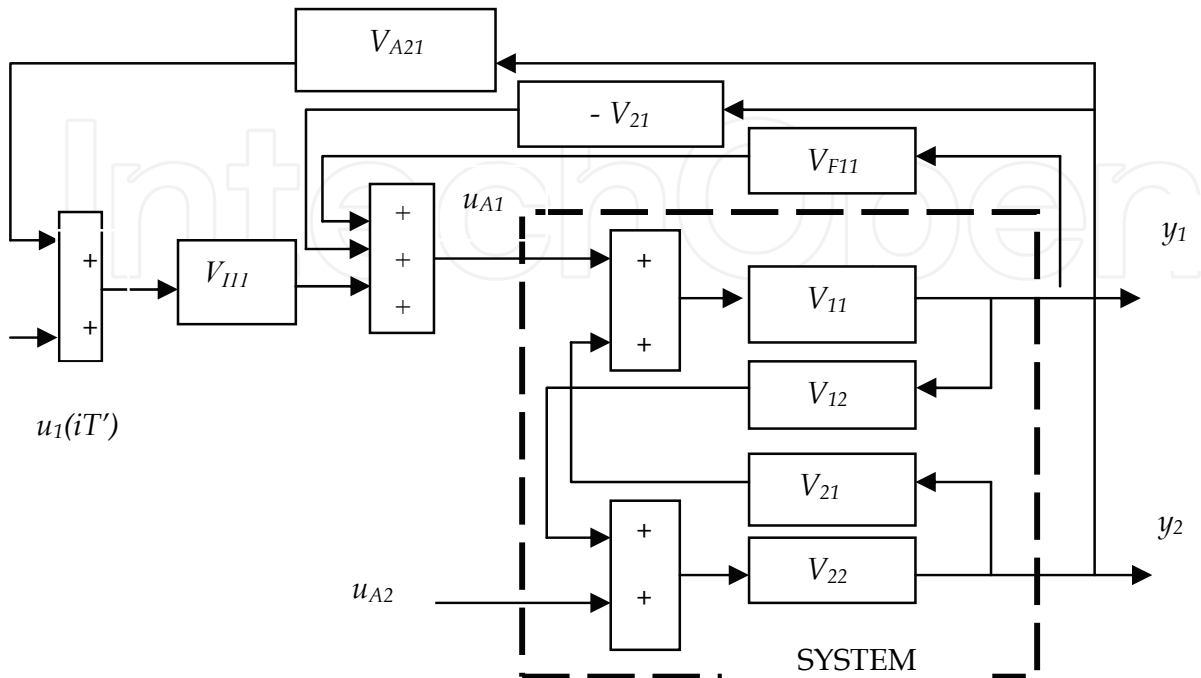

Fig. 7. The synthesis of signal u_{A1} for scaling of SYSTEM output signal y_1 . To avoid the illegibility of scheme the sub-structure generating signal u_{A2} has not been attached. Note, that effect of time-scaling has been achieved without modification of internal structure of SYSTEM.

Example C. For simplicity, let us consider the linear, continuous-time MIMO system where

$$\begin{aligned} V_{11}(s) &= [6s^2 + s + 1]^{-1}, & V_{22}(s) &= [12s^2 + 4s + 1]^{-1}, \\ V_{21}(s) &= -10s^2, & V_{12}(s) &= -5s^2. \end{aligned} \quad (16)$$

Let us assume, that forms of system responses $y_1(t)$, $y_2(t)$ to excitations $u_1(t)$, $u_2(t)$ fulfil technical needs and ought to be conserved. However, they are too “fast” and $y_1(t)$, $y_2(t)$ have to be slowed down 2 times ($A=0.5$). Moreover, let us assume, that one cannot change the system parameters. The solution of this task can be found using the idea of time-scaling, for example, by processing the discrete-time V-model of system. Using Tustin’s transform one obtains:

$$\begin{aligned} V_{11}(z) &= 0.0833 T^2 (z^2 + 10z + 1) (M_{11}(z))^{-1}, & V_{22}(z) &= 0.0833 T^2 (z^2 + 10z + 1) (M_{22}(z))^{-1}, \\ V_{21}(z) &= -120 T^{-2} (z^2 - 2z + 1)(z^2 + 10z + 1)^{-1}, & V_{12}(z) &= -60 T^{-2} (z^2 - 2z + 1)(z^2 + 10z + 1)^{-1}, \end{aligned} \quad (17)$$

where :

$$M_{11}(z) = (6 + 0.5T + 0.0833T^2) z^2 + (0.8333T^2 - 12) z + 0.0833 T^2 - 0.5T - 6,$$

$$M_{22}(z) = (12 + 2T + 0.0833T^2) z^2 + (0.8333T^2 - 24) z + 0.0833T^2 - 2T - 12.$$

The responses of system discrete model for sample time $T=1s$ are shown in Fig. 8. The excitations of system have been obtained using (14). The elements $V_{mj}(z)$ of structure in Fig. 6 have been scaled according to rules described in Section 2.1.

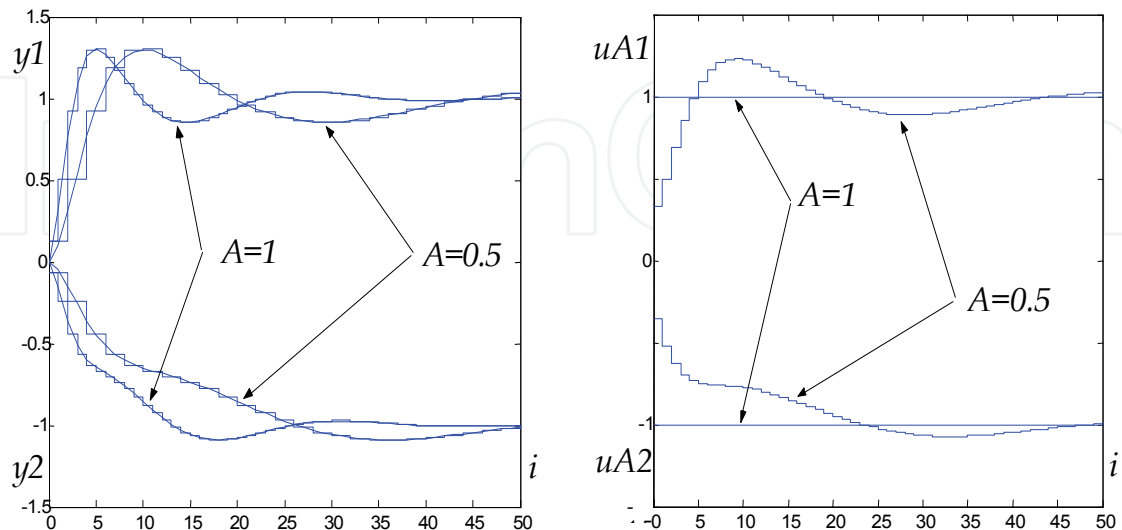

Fig 8. Result of scaling of outputs $y_1(t), y_2(t)$ (solid lines – responses of system to excitations u_{A1}, u_{A2} , staircase lines- responses of discrete-time model of system) and discrete-time signals u_{A1}, u_{A2} supplying system .

4. Conclusions

1. The scaling of SISO systems is realised by equipping them with INPUT and FEEDBACK correctors (Fig. 2). It makes, that external loops process the system output signal as well as system state variables and internal structure of system is not affected.
2. The scaling of MIMO system is based on its "V" model and can be implemented, if linear and nonlinear SISO elements of this model can be scaled using SISO structure shown in Fig. 2.
3. The presented algorithms can be successfully applied to discrete-time models of continuous-time systems (see Example C). Thus, the discrete-time algorithms can occur helpful for time-scaling of responses of continuous-time systems.
4. The perfect scaling of stable system conserves its stability. Furthermore, the frequency representations of signals and systems after scaling can be immediately determined on the basis of reference representations (from before scaling).
5. The considerable number of parameters representing system and associated signals in time domain and frequency domain can be treated as invariant while system dynamic properties are changed according to rules of time scaling. This advantageous feature allows to design the advanced control algorithms which conserve the crucial parameters characterising the control process (overshoots, steady state errors, stability margins, etc.) if plant responses have to be slowed down or speeded up. The control algorithms using idea of time-scaling process the plant state variables. That is why the well known MFC structure can be advised for implementation purposes (Durnaś & Grzywacz, 2001; Durnaś & Grzywacz, 2002; Grzywacz, 2006).

6. The attractive area of applications of idea of time-scaling seems to be that dealing with algorithms for control of robot drives. If displacements along x,y,z - axes are scaled with the same A , then forms of space trajectories of robot movement for various A are identical (they do not depend on speed of robot movement).

5. References

- Chen Hui, L. (1983). *General Decoupling Theory of Multivariable Process Control Systems*. 1983, Springer - Verlag, Berlin - New York.
- Durnaś, M. & Grzywacz, B. (2001). Application of idea of time-scaling to synthesis of linear and non-linear control systems. Proc. 7th IEEE Int. Conf. Methods and Models in Automation and Robotics, pp. 284 - 290, ISBN 83-88764-75-6, Międzyzdroje, Poland, August 2001.
- Durnaś, M. & Grzywacz, B. (2002). Application of idea of time-scaling to control of nonlinear plants represented by cascade consisting of Wiener and Hammerstein models. Proc. 8th IEEE Int. Conf. Methods and Models in Automation and Robotics, pp. 1263 -1268, ISBN 83-88764-51-9, Szczecin, Poland, September 2002.
- Grzywacz, B. (2006). The Time-Scaling of Responses of MIMO Systems. Proc. of 13 IEEE Mediterranean Electrotechnical Conference MELECON, pp. 429 - 432, ISBN 1 4244 0088 0, Malaga, Spain, May 2006.
- Moya, P.; Ortega, R.; Netto, M. & Praly, L. (2002). Application of Nonlinear Time-Scaling for Robust Controller Design of Reaction System. *International Journal of Robust and Nonlinear Control*, Vol.12, 2002, pp. 57 - 69, ISSN 1049 - 8923.
- Respondek, W.; Pogromsky, A. & Nimejer, H. (2004). Time-scaling for observer design with linearizable error dynamics. *Automatica*, Vol. 40, No. 40, February 2004, pp. 277 - 285, ISSN 0005 - 1098.

IntechOpen



New Approaches in Automation and Robotics

Edited by Harald Aschemann

ISBN 978-3-902613-26-4

Hard cover, 392 pages

Publisher I-Tech Education and Publishing

Published online 01, May, 2008

Published in print edition May, 2008

The book *New Approaches in Automation and Robotics* offers in 22 chapters a collection of recent developments in automation, robotics as well as control theory. It is dedicated to researchers in science and industry, students, and practicing engineers, who wish to update and enhance their knowledge on modern methods and innovative applications. The authors and editor of this book wish to motivate people, especially under-graduate students, to get involved with the interesting field of robotics and mechatronics. We hope that the ideas and concepts presented in this book are useful for your own work and could contribute to problem solving in similar applications as well. It is clear, however, that the wide area of automation and robotics can only be highlighted at several spots but not completely covered by a single book.

How to reference

In order to correctly reference this scholarly work, feel free to copy and paste the following:

Bogdan Grzywacz (2008). Time-Scaling of SISO and MIMO Discrete-Time Systems, *New Approaches in Automation and Robotics*, Harald Aschemann (Ed.), ISBN: 978-3-902613-26-4, InTech, Available from: http://www.intechopen.com/books/new_approaches_in_automation_and_robotics/time-scaling_of_siso_and_mimo_discrete-time_systems

INTECH
open science | open minds

InTech Europe

University Campus STeP Ri
Slavka Krautzeka 83/A
51000 Rijeka, Croatia
Phone: +385 (51) 770 447
Fax: +385 (51) 686 166
www.intechopen.com

InTech China

Unit 405, Office Block, Hotel Equatorial Shanghai
No.65, Yan An Road (West), Shanghai, 200040, China
中国上海市延安西路65号上海国际贵都大饭店办公楼405单元
Phone: +86-21-62489820
Fax: +86-21-62489821

© 2008 The Author(s). Licensee IntechOpen. This chapter is distributed under the terms of the [Creative Commons Attribution-NonCommercial-ShareAlike-3.0 License](https://creativecommons.org/licenses/by-nc-sa/3.0/), which permits use, distribution and reproduction for non-commercial purposes, provided the original is properly cited and derivative works building on this content are distributed under the same license.

IntechOpen

IntechOpen