

We are IntechOpen, the world's leading publisher of Open Access books Built by scientists, for scientists

4,800

Open access books available

122,000

International authors and editors

135M

Downloads

Our authors are among the

154

Countries delivered to

TOP 1%

most cited scientists

12.2%

Contributors from top 500 universities



WEB OF SCIENCE™

Selection of our books indexed in the Book Citation Index
in Web of Science™ Core Collection (BKCI)

Interested in publishing with us?
Contact book.department@intechopen.com

Numbers displayed above are based on latest data collected.

For more information visit www.intechopen.com



Robin Heart - Perspectives of application of mini invasive tools in cardiac surgery

Zbigniew Nawrat^{1,2}, Pawel Kostka^{1,3}

*Foundation for Development of Cardiac Surgery, Zabrze Poland,
Medical University of Silesia, Katowice,
Silesian University of Technology, Gliwice,
Poland*

1. Introduction

Robot invented for less, minimally invasive cardiac surgery is a computer-controlled device, located between surgeon's hands and the tip of a surgical instrument. Basic requirements for this device are first of all high reliability, stable operative field of view, direct surgeon control and high level of precision.

The Robin Heart® is a Europe's first heart surgery robot system with whole, original Polish design. Precise and optimally adapted to the surgeon's manual dexterity, it also helps him make the right decisions. Around 4 million minimally-invasive surgeries are performed in the world every year. The procedures are performed by means of special instruments inserted through small incisions in the patient's body. The aim is to limit the operative field and protect surrounding tissue, which could be damaged if a traditional surgical technique was used. The number of endoscopic procedures, less invasive than traditional surgery, performed through natural orifices in the patient's body, or through special openings called ports, is on the rise.

The success of the procedures largely depends on the instruments used. Unfortunately, typical endoscopic (laparoscopic) instruments reduce precision and make the surgery more difficult because they add to hand tremor and almost completely eliminate the natural sense of touch. Additionally, the surgeon does not have a direct view of the operative field—a camera inserted into the body through a third opening transmits the image to a display. So the surgeon's task is not easy. An ideal non-invasive surgery can be compared to the house renovation through a keyhole without disturbing the household members. Across the world, physicians and engineers are working to develop increasingly effective instruments to enable surgery with the use of the latest technology. But how can one enhance instrument precision and maneuverability, which are so important in the case of surgery on the beating heart, for instance? Surgical robots provide such capabilities.

In Poland, an interdisciplinary team led by Prof. Zbigniew Religa already introduced modern devices to clinical practice to save the lives of heart patients. An artificial heart, prosthetic heart valves and recently a surgical robot are the results of projects carried out by the Biocybernetics Laboratory of the Heart Prosthesis Institute, a research center run by the

Source: Medical Robotics, Book edited by Vanja Bozovic, ISBN 978-3-902613-18-9, pp.526, I-Tech Education and Publishing, Vienna, Austria

Foundation for Cardiac Surgery Development in Zabrze. This is the only one research center of such a kind in Poland.

Works on building a prototype of a remote-controlled robot for performing and assisting heart surgeries and other surgical procedures was initiated in 2000. At the starting point of RH project the multidisciplinary team from several scientific centers in Poland was setup. The group of basic constructors both of mechanical and electronic part was mounted (fixed) consists of Leszek Podsedkowski, Krzysztof Mianowski and the authors of presented paper. The robot, or actually a "tele-manipulator," is the first ever tool capable of assisting a surgeon by providing the capability to directly use surgery simulation and planning methods. Several models of the robot have been developed, differing in control and mounting systems. The Robin Heart 0 and Robin Heart 1 have an independent base and are controlled via an industrial computer (with VME type bus) and author's software written in OS9 real time operating system. The Robin Heart 2 is fixed to the operating table and has two arms, on which one can fix various surgical instruments. The control system is implemented based on the Digital Signal Processor (DSP) as a central unit and net of motor regulators, created on specialized microcontrollers. The latest model, known as the Robin Heart Vision, will become the surgeon's partner in the operating room next year. It will replace a human assistant who usually holds the "telescope" of the video channel to enable the observation of the operative field of laparoscopic instruments. As a result, the surgeon will be able to perform part of the surgery unaided by other people. The Robin Heart Vision is easy to use and install, and can be conveniently carried in a suitcase. The Polish heart surgery robot is an original design. Thanks to its modular structure, it can be adjusted for surgery of different types. Work is under way to introduce a "tele-collaboration" (Robin EXPERT) system to be used during surgery. It will contain the real image from the camera, diagnostic data and surgery simulation data. The surgeon will be able to use the "tele-collaboration" program at any moment as it will be voice-activated and voice-controlled. New instruments and applications for the robot are also being developed. There are plans to use the robot for implanting artificial organs, prostheses and ventricular assist devices (AOROBAS project).

Results of works carried out in the range of RH project realisation were given under a public evaluation during annual Surgery Robotic Conference, started in 2001, in FCSO (Zabrze, Poland). Mentioned above conference - Medical Robots Conference, currently achieved the status of international platform for participant's projects presentation, exchange of experiences and is also occasion for polish Robin Heart system testing. Promotion action conducted from the beginning of the project realisation as well as fact, that the big group of young scientists and students were involved in it was the reason, that this pioneer project became an initial sparkle of huge wave of interest in medical robotic systems in polish universities. Currently several polish technical and also medical universities created autonomous faculties of medical robotics and run the lectures from this disciplines. Now there is a enormous and encouraging perspective for the development of surgical robotics in Poland - while all began from the short conversation between physics (dr Zbigniew Nawrat (ZN)) and famous cardiac surgeon (prof. Zbigniew Religa (ZR)):

ZN: We call it Robin Heart, Professor !

ZR: OK! When will I be able to operate with it?

1.1 Short historical review of surgery robotics

Robotic surgery was born out of microsurgery and endoscopic experience. Minimally invasive interventions require a multitude of technical devices: cameras, light-sources, high-frequency and insufflations. The mobility of instruments is decreased (from seven, natural for human arm, to four degrees of freedom DOF) due to the invariant point of insertion through the patients wall. Many companies worked on methods for doctors to do heart surgery through small holes in the patient's chest but with a computer controlling the movements of the long sticks. The surgery is a complex procedure requiring precise control of position and force. Conventional open-heart surgery requires full median sternotomy, which means cracking of ribs, compromising pulmonary function and considerable loss of blood. The basic advantages of minimally invasive robot-aided surgery are safe, reliable and repeatable operative results with less patient pain, trauma and recovery time.

The milestones of video-enhanced telescopes (laparoscopes) and tele-manipulators:

- 1805 Bozzini – first use a vision system in the body (urethra stones)
- 1912 Jacobeus - laparoscopy examination the abdomen
- 1945 Goertz - first modern tele-manipulator (applied to space investigation, undersea exploitation, nuclear industry, medical therapy ...)
- 1960s Semm et al. – developing of laparoscopic instrumentation
- 1983 Semm – first laparoscopic appendectomy
- 1987 Mouret - first laparoscopic cholecystectomy
- 1993, 1994 Green et al. – developing the telepresence surgery (master and slave units were connected via a short cable to perform surgical actions such as grasping and cutting)
- 1993 Rovetta et al. – first experimental robotic telesurgery by means of satellites network (USA -Italy)
- 1994 – first FDA-cleared robot for assisting surgery (Automated Andoscopic System for optimal Positioning AESOP produced by Computer Motion)
- In 1995, Intuitive Surgical was founded
- 1998 Carpentier&Loulmet performed first in the world endoscopic operation of single bypass graft between left internal thoracic artery and left anterior descending (LITA – LAD) and 1998 first operation inside the heart – mitral valve plastic and atrial septal defect closure was performed (da Vinci)
- 1998 Mohr & Falk bypass surgery and mitral valve repairs in near endoscopic technique (da Vinci)
- 1999 D.Boyd – first totally endoscopic Zeus-based coronary artery bypass graft (E-CABG)
- 1999 – 250 robotically assisted operations performed worldwide among which 80 have been cardiac procedures 100 heart operations using da Vinci (Intuitive Surgical, Mountain View, CA) were performed.
- In 2000, da Vinci Surgical System became the first robotic surgical system cleared by the FDA for general laparoscopic surgery
- 2000 - Start polish project Robin Heart

In 2003, the Intuitive Surgical acquired its principal competitor, Computer Motion, strengthening its intellectual property holdings. While Intuitive Surgical supports Computer Motion's former customers, most hospitals and institutions that had Computer Motion's ZEUS® MicroWrist™ Robotic Surgical System for minimally invasive surgical procedures

have chosen to participate in a trade-in program and now have da Vinci Surgical Systems. Intuitive Surgical continues to sell some AESOP® Robotic Endoscope Positioners, but primary focus remains the da Vinci Surgical System (www.intuitivesurgical.com).

In 2005, a total of 2984 cardiac procedures were performed worldwide using the da Vinci system. This includes totally endoscopic coronary artery bypass grafting (TECAB), mitral valve repair (MVR) procedures, ASD closure and cardiac tissue ablation for atrial fibrillation (Jacobs et al., 2006). In 2003, the number stood at a modest 3.4%. In 2004, the number climbed to 10% and then doubled to 20% the following year. For 2006, the figure is expected to come in around 35%. An estimated 36,600 robotic procedures will be performed this year – from heart-bypass surgeries to kidney transplants to hysterectomies. That's up nearly 50 percent from last year, and analysts predict the figure will nearly double in 2006 to more than 70,000 procedures. Since the da Vinci was approved by the Food and Drug Administration in July 2000 (the only robotic system to get the FDA nod), about 350 of the units have been purchased, including 30 in the last quarter alone, at about \$1.3 million apiece (after J. Barrett, [Newsweek](#), Dec. 4, 2005).

2. Assumptions and initial steps of Robin Heart project

The Foundation of Cardiac Surgery Development (FCSD) in Zabrze began in 2000 the grant for realization of the prototype of a robot useful for cardiac surgery. The multidisciplinary team including specialist in medicine and techniques during three years prepared families of robot prototypes named Robin Heart (Fig.1).



Figure 1. The Robin Heart 1

The goals of the project was:

- Safe, reliable and repeatable operative results with less patient pain, trauma and recovery time
- Healthcare costs decreasing
- Support the technology breakthrough - significant increase of the number and type of minimally invasive procedures available to patients.
- Friendliness guarantee both for the patient and surgeon.

Design criteria & problems:

Man-Machine interface - the design of surgeon user interface. We worked out many models of suitable for surgeon contact systems, using the experiences of centres designing the artificial hand and HAPTIC systems. Master tool similar to traditional laparoscope with sensors, solutions based on PC like joystick, head movement interface (for RH Vision endoscopic arm), foot pedal control and voice commands.

Safety - checking the quality of device execution, working on the multi-type sensor systems including the arm sensors and image processing information

The advisory systems - supporting the operation planning. Using the experiences of our Bio-Cybernetics Lab. FCSD in cardiac surgery procedures simulations we work on the system for recognizing the object, comparing it with diagnostic image from data base and advising the surgeon the optimal solution.

Surgical tools - working out of series of universal and specialised small, elastic, adaptive control and easy to operate, tools for performing the concrete activities during the cardiac procedure. The experience in clinical beating heart cases has demonstrated the importance of small instrumentation to successfully complete these procedures. The space in the chest when performing a beating heart case is limited to about 3 cm between the chest wall and the target vessel. The working tips of microsurgery instruments must be smaller than 5 mm to not obscure the small endoscopic field of view and efficient maneuver in the small space within the chest. The bigger instruments are not able to effectively articulate due to the wide space that is swept out when articulating, thus negating any benefit articulation might afford. We plan the usage of micro-engines, elastic grabbers matching their properties to the object shape and application the new materials - alloys with shape memory, diamonds facing etc.

The testing and training stands - every part of robot, before introducing to the further designing stage will be tested by physicians on special prepared stands

Small invasive placing the artificial organs - we work out the ways of valves, heart assist pumps and pacemakers - fixing etc. Especially the semiautomatic tools for canula implantation is designed.

Assistant - the assistant in beating heart cases can provide counter traction for the arteriotomy, facilitate suturing during the anastomosis and must be able to effectively integrate amongst the robotic arms to use a mister/blower to clear the field.

Port - optimal port location is necessary to provide a significant benefit to the patient, ensures patient safety and minimizes any pain at the port site. For surgery planning, optimal port location and robot's arm navigation the virtual reality technology was used.

Sterility - the robot system have to be easy configured for the sterile field. The arms are draped.

According to assumptions Polish cardiac surgery robot was to be an original construction with segment type structure to allow the combination of its parts for different type of surgery operation.

2.1 Minimally Invasive cardiac Surgery (MIS) description

The minimally invasive cardiac surgery may be performed manually using classic, modified semi-classic tools or in robotic supported way. Currently several techniques are used. The most important application of MIS is the coronary artery bypass grafting CABG.

2.1.1 CABG MIS description

Coronary bypass surgery is common (about 800 000 people undergo the procedure every year worldwide) but the operation is expensive and risky. Grafting bypasses onto the heart typically involves attaching between three and five vessels to existing arteries so that blood flow through the bypasses will circumvent blockages. Surgeons can use either arterial grafts (arteries, mostly, left internal mammary artery (LIMA), redirected from the vicinity of the heart) or venous grafts (vein segments taken from the leg).

Full sternotomy means that surgeons must open the chest (sternum must be split with a saw and the chest cavity spread open). Next, they must stop the heart and the patient must be put on heart-lung machine, which artificially circulates blood and supplies the body's tissues with oxygen until doctors restart the heart. In the mid-1990s new surgical techniques emerged that signal a revolution in coronary bypass surgery.

We have to explain a meaning of few medical abbreviations used in field of MIS:

MIDCAB - minimally invasive direct coronary artery bypass grafting done through a left anterolateral minithoracotomy. The surgery is performed by a beating-heart approach (10% of this kind operation) and a pressure stabilizer is used. It is applicable, for the most part, only single vessel disease on anterior surface of the heart.

MIS require special techniques for connection circulatory system for artificial perfusion.

Port Access Surgery - this is the method for cardiopulmonary bypass system using in case of coronary bypass grafting through a limited access incision on an arrested heart.

OPCAB - off-pump coronary artery bypass grafting. The surgery (multi-vessel disease) is performed through a small sternotomy approach on beating heart using stabilizers. In many centers in Europe and in the United States, greater than 90% of all CABG is now performed by OPCAB techniques, because of its ability to multi-vessel surgery and allowing access to the posterior circulation of the heart without significant hemodynamic compromise.

TECAB - Totally Endoscopic Coronary Bypass Surgery - the surgery performed without of sternotomy using only observation via endoscopic camera.

AORobAS -- Based on Robin Heart project development, currently our team works on system AORobAS - Artificial Organs Robotically Assisted Surgery artificial organs implantation, services, repair, exchange, removing.

Endoscopic microsurgery is difficult to carry out with standard hand held instruments. This due primarily to the poor ergonomic position that results when a surgeon stands at the table using standard endoscopic instruments to perform a complex surgical task. Robot is intended to keep the surgeon in the most comfortable, dexterous and ergonomic position for the entire procedure. In most assisted by robot surgery procedures, only part of heart procedure are made using robot, for instance mammary artery harvests. The first ever in US closed-chest totally endoscopic coronary artery TECAB bypass procedure was performed (Argenziano& Craig in New York) using the da Vinci System from start to finish only in January 2002. The first robot assisted operation inside the heart was also mitral valve plastic and atrial septal. Currently the application of cardio-robots is developed in wider range of

surgery procedures. For us, Institute of Heart Prostheses FCSD the most interesting is surgery connecting to artificial organ implantation.

2.2 Preliminary tests creating the base for surgery robot assumptions

Cardiac surgery is carried out on soft tissues.

Results connected with surgical action analysis allowed to determine the maximum values of forces needed for typical procedures performed in heart area, with the usage of different type tools. This can be the basis for cardiac surgery robot design assumptions, in the field connected with controlling of robot tools movements.

The penetration of soft tissue requires such action as cutting, slicing, inserting a needle, knotting etc. The difficulty with soft tissue consist in fact, that it deforms and changes shape. As our result of basic mechanical properties of typical surgical actions the map of force resistance during pricking for left and right heart chamber was obtained. For example the maximal force value of heart muscle right ventricle equalled 30[G] (1[cm] depth) and 90[G] (2[cm] depth) for Dexon 2/0 surgical needle, while for Prolene 3/0 type 40[G] and 140 [G] respectively. This same needle Prolen during pricking through papillary muscle reached the max. load, up to 150 [G]. During scalpel cutting procedure for left ventricle (the mitral valve ring) the measured load value equalled 200[G] (2[cm] depth). For sewing tests - the knot tying using Prolen needle: up to 200[G], with 0.1 [mm/s] test speed.

2.3 Consideration toward Robin Heart construction

Basic idea of the manipulator Robin Heart consists of mechanisms realizing fixed in space "constant point", consists of two closed kinematics' chains (Nawrat et al., 2003). The first loop is in fact a typical parallelogram mechanism, used as a transmission mechanism coupled with the second one realized inverse mechanism. By special connection of two rotations coupled by constant angle internal link, the mechanism can change external angle to approximately 150 degrees. In the version Robin Heart 0 shown in Fig.2, the first DOF is driven by electric, brushless motor integrated with Harmonic Drive gear. The second (range up to 150 degrees doubled system of parallel mechanisms) and third DOFs (the parallel mechanisms eliminates the necessity of using a linear slideway) are driven by brushless motors, roller screws and system of strings. The construction makes possible fast and not complicated disconnection the drive part of the bunch from the manipulating part.



Robin Heart 0



Robin Heart 1



Robin Heart 2

Figure 2.

The separable part does not contain any elements requiring lubrication. In the bunch part five independent drives and the string drive were applied gives 3 DOFs enable to obtain any orientation in the workspace. The fourth DOF makes possible opening and closing the jaws of the tool, the fifth one (called "the elbow") is redundant and increases manoeuvrability, enables avoiding obstacles and operating "backwards". In the pre-prototype version the diameter of the bunch is 10mm. For driving, the servomotors with DC electric motors and no-clearance gears have been used.

Presented above preliminary prototype (number 0) have been tested and the new prototype have been designed. In prototype Robin Heart 1 (Fig.2) diminution of mass and size of tools driving block, enlargement of stiffness of arm and arrangements of carriage of drive were introduced. As a results driving block has dimensions 46 x 48 x 90 mm and five times smaller mass (0,4 of kg). Additionally project of so-called „penknife“, universal possessing ending more than one working tool element was executed. In Robin Heart 1 the diameter of the bunch was decreased to 8mm (Nawrat et al., 2003).

In addition, we decided to perform also, competing model of robot arms: relatively light construction mounted directly to the operating table. In construction Robin Heart 2 (Fig.2) compact versions modules of parallelogram mechanism were placed inside compactly to them of well-fitting elements consist of rectangular pipes. Advantage of this solution is straight, aesthetical, compact and tight construction presenting high functionalities in operating action. Manipulator is driven by DC servomotors. The arms is mounted to the table using special folding console from two passive arms and columns.

The Robin Heart 2 manipulator has very good and relatively large working space, in which surgeon can select small subspace with very good isotropic kinematics' properties for manipulating of objects with good position accuracy. Each of models are under testing program provided in Bio-Cybernetics Laboratory.

2.4 Robin Heart Vision (RHV) chosen technical and functional assumptions.

RHV telemanipulator is a youngest member of RH family designed as a robotic holder for endoscopic camera, so it is equipped with special socked for quick endoscope fixing.

Based on RH0&RH1 constructions the set of technical assumptions was created as well (Nawrat & Kostka, 2007):

- Four degrees of freedom (DOF)
- Relatively large working space (see Results chapter for detail info).
- Resolution less or equal 0.5 mm

As a one surgery robotic arm RHV is adapted to be fixed both directly to operation table and to stand on autonomous column next to it.

2.5 Operation field and techniques analysis for robotic supported cardiac surgery.

The main assumption that makes Robin Heart 1 useful, is construction of double closed loop, which provides point constancy between laparoscope instrument and patient tissue. To optimize this type of construction, Robin Heart structure was based on a double closed loop mechanism, which provides constancy of a point outside the robot structure. In this way only one reliable servomotor is used with a simple steering algorithm.

To identify the 'constant kinematics point' and to explain the necessity and the principle of working this type of structure, a separate simplified model was created in a CAD program.

Overlapping all final position of the Robin Heart 3D model, the geometric position surface of laparoscopic instrument was described in geometry and dimensions.

To provide all necessary functionality of modern laparoscopic devices, robot Robin Heart gives user a three degrees of freedom to orientate in space, fourth one is responsible for opening and closing jaws of the tool and the fifth one increases the manipulation skills to avoid obstacles, or like Robin Heart allows to work "backwards". Standard laparoscopic device has got a limited mobility and do not offer very sophisticated types of movement that are provided by a robotic systems. To see the differences in a mobility between two various Robin Heart instruments, a tool workspace was calculated for a robot equipped with a standard laparoscopic device and a more advanced robotic instrument (Fig.3.). Having a workspace sphere calculated for all of the robot instruments it is very easy to verify the goal of using a suitable device for a proper surgery treatment. Combining this workspace with a geometric position surface we were able to calculate the total range of movement for both robotic instruments inside the patient body (Fig.4.).

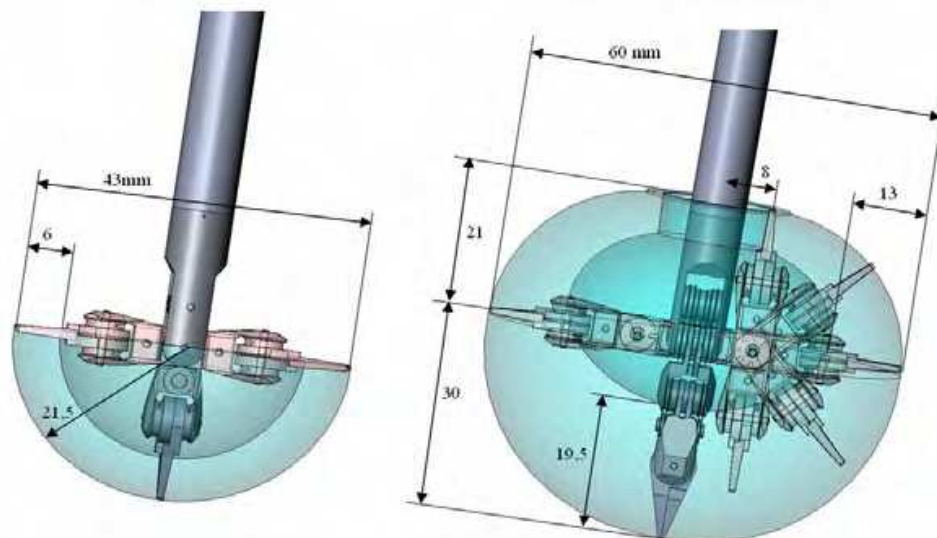

Figure 3. Instrument workspace: a.) standard laparoscopic tool, b.) Robin Heart 1 instrument. (performed by Kozlak&Nawrat)

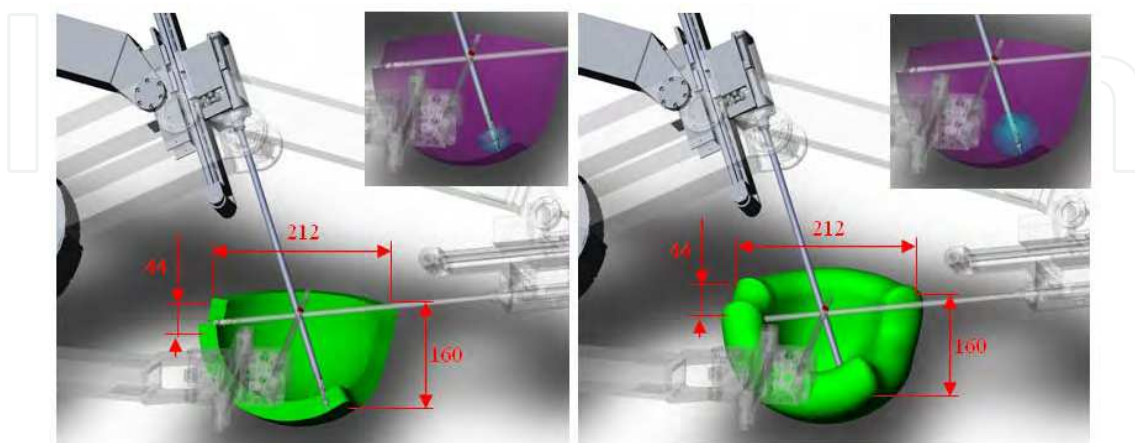

Figure 4. General range of robot mobility equipped with: a.) standard laparoscopic tool, b.) Robin Heart 1 instrument (performed by Kozlak&Nawrat)

2.6 Virtual Reality modeling

To be up to date the part of Robin Heart system research and the modeling work is using a Virtual Reality latest technology. Nowadays in a RiH project this technology is implemented in a three different areas that cooperate together in creating an advanced computer system for a surgery planning. In this manner a Virtual Reality equivalent of surgery scene (Fig.5,6) was created including: - three separate Robin Heart robots that can be manipulated realistically with all of their functionality; - a human model with basic organs; - surgery room and all the basic equipment. This type of intuitive understanding of virtual objects was used by FCSD to create a several training station that helps us better to see the benefits of robotic surgery and how to use a robotic system during the surgery treatment. All of the virtual Robin Heart robots were connected to the native wireless controllers, so having a true joysticks in your hands user can manipulate and stand next to the robots that actually do not exist. Virtual copy of those robot prototypes are able to perform all of the movements and provides the same behavior as the origin Robin Heart. Possibility of interaction between all of the three robots and the surrounding virtual objects is a great chance of an advanced training for young surgeons but also gives an opportunity to plan (or even practice) surgery procedures that have to be perform in the real world by a professionals.

Efficiency of using a robotic equipment in an endoscope procedures significantly depends both on a precise tools manipulation and a proper surgery procedure planning. Accurate arrangement of setting up the robots arm with reference to surgery table, positioning the trocars location and right choice of a correct tools, makes the surgery procedure much more safe and harmless. Using a virtual reality technology, based on EON Reality interactive software, we plan all those important steps, increases an effectiveness in noninvasive surgeons training and helps to verify the benefits of using robotic systems in a various surgery treatments.

To be up to date the part of Robin Heart system research and the modeling work is using an EON Reality Virtual Reality latest technology. Because VR is a very intuitive solution this type of modeling gets much more popular nowadays helping surgeons and even patients to understand very complex procedures much more clear and efficient. Nowadays in a RiH project VR technology is implemented in four different areas:

- as a training station in surgeon education process,
- as a tool used for a surgery treatment procedure planning with a step by step briefing, - in an advisory voice operated system with an external database,
- to verify a different construction versions in aspect of ergonomic and functionality.

FCSD has used a Virtual Reality technology to create several training station that helps user better to understand the benefits of robotic surgery and how to use a robotic system during the surgery treatment. The total impression of immerse in a computer world was emphasized by using a special active stereoscopic projector and a shutter glasses. The total Virtual Reality scene was completed with a three separate Robin Heart robots that can be manipulated realistically with all of their functionality; endoscope camera viewport displayed in a PIP technology (picture in picture), human model with basic organs which might be exchanged to ones from a patient CT or NMR; surgery room with a surgery table, lamps and all the basic equipment. Prepared VR model and also a Robin Heart training system was created in a EON Professional, and fully supports real time rendering with advanced graphic effects, contact between the objects, friction, gravity and a mass properties. Foundation for Cardiac Surgery Development is using virtual model: to verify

the choice of using a specific instrument inside the surgery area by comparing the size and the shape of the different workspaces; to plan and simulate the surgery treatment with step by step instructions; for a surgery room choreography optimizing the position of each robot arm for different procedures; to set the correct trocar ports between the patient ribs; to educate how to use an endoscope camera during the surgery procedure.

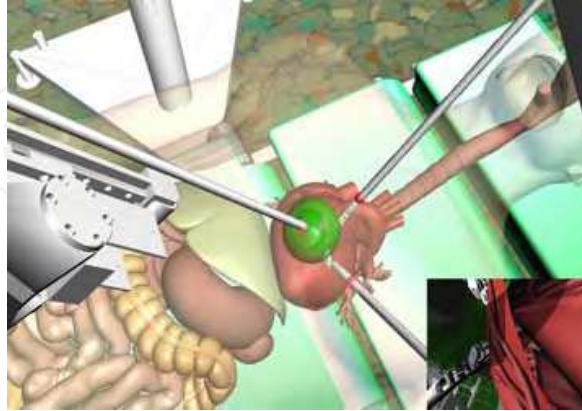

Figure 5. Robin Heart surgery scene planning inside the patient body

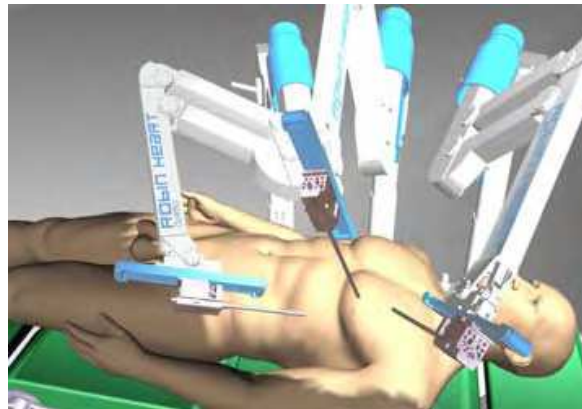

Figure 6. Robots choreography planning and training (*performed by Kozlak&Nawrat*)

2.7 Planning of robot assisted cardiac surgery

Pre-operation planning means several researches using computer and physical models, performed to reach optimisation surgery effect by optimisation of methodology, materials, devices and techniques of surgery.

Modern medical imaging methods like computer tomography (CT), nuclear magnetic resonance (NMR) enable the surgeon to view very precise a representation of internal anatomy from pre-operative scan modalities. Scan can be combined with an anatomical atlas producing 3-D patient model and the model of devices like artificial heart or valve can be add for treatment planning prior the operation. For surgery robots (telem manipulator) the following distinct phases can be recognised:

- pre-operative planning: The optimal strategy is defined based on 3-D computer model.
- robot assisted intervention: A calibration routine brings robot, patient and image system to common frame of reference – e.g by anatomical (or artificial) landmarks.
- feedback and re-planning: The robot starts the to work under supervision of surgeon. Sensor information assure that the anatomy is as expected and stored by a model in

computer. If deviations occur the surgeon asked for a revised strategy, or for permission to continue.

The image - guided surgery is easy to implement for orthopedic surgery, where fixators are commonly used to fix bones, and also for neurosurgery, where the stereotactic helmet, mounted on the patient's head, is quite popular to provide absolute matching between pre-operative and intra-operative reference frames. Vision - based surgery may be viewed as a robotic CAD-CAM system where diagnostic images (from CT, NMR, US, etc.) are used for off-line planning of the intervention. The robot is used as a tools-machine for precise cutting, milling, drilling ..(for instance bone milling for hip implant). The geometrical precision of the surgical planning often greatly exceeds that of surgical execution that the solve is partnership between humans and computers and robots. For example, Robodoc (ISS Inc., Sacramento, CA,USA) is it industrial system currently used in human trials for implant of hip prostheses. The architecture of the hip replacement surgery system consist of a CT-based presurgical planning sub-system. The surgical procedure includes manual guiding to approximate positions of pins, pre-operatively inserted into bones and automatic tactile search for each pin. Robots controller computes the appropriate transformation to machine out the implant cavity. Then, the pins are removed and the surgeon proceeds in the manual procedure. Robodoc include checking and monitoring of cutter force. Similar techniques adapted to different scenarios have been developed for the cases of total knee arthroplasty, spine surgery, neurosurgery, prostate and eye surgery.

For medical application very important are matching procedures between diagnostic images and off-line intervention planning and real execution. Many problems still remain for soft tissue surgery where deformations may occur. The navigation and guidance of the instruments highly depends on the surgeon's skill who has to combine his intra-operative views with the information extracted from the pre-operative images. System currently developed in our laboratory allows for parallel displaying, four pictures on monitor taken from independent sources (e.g. one real from operation field, next - diagnostic images or pre-operation simulation results).

To plan the whole surgery procedure by means of physical and mathematical models, particular objects belonging to field of operation should be characterized in this domain.

We propose an original solution of remote-control manipulator for cardiac surgery with computer based advisory system. Information gathered in prepared database may be use by surgeon as on-line expert system to support him in decision making. A first step is to prepare the robot-assisted surgery relates to both computer and physical models of particular operation type. Based upon pre-operation cardiac surgery simulations the optimisation of cardiac surgery procedures can be established. The implementation of in vitro simulation for surgery procedure has been performed. As a results of a physical and computer simulations (ProEng®, Fidap® systems) surgery modification of biological system effectiveness with the different surgery techniques usage is studied. As a result of research connected with operation planning the optimisation of port location and choreography of robot arm for this cases is performed. Based on this works effects, the control algorithm for cardiac surgery robot will be proposed.

Currently used cardiac surgery robots fulfil the function of manipulators, which main task is to detect and scale up or down the surgeon hand motions and precisely translate them to the movements of robot's arm equipped in appropriated tools. The basic advantages of cardio-

robots are safe, reliable and repeatable operative results with less patient pain, trauma and recovery time.

The main issues of computer simulation support of surgery robot:

1. The operation planning – Based on diagnostic data (images, pressure and flow signals, etc.) computer and physical models can be created. In vitro simulations performed on them, may be used to find the optimal way of operation (the joint point localization, the graft selection). Prepared report can be presented to surgeon as a hint for robot choreography planning. This stage also should include: input port localization on patient skin, the type of tools and the way of taking and preparing the graft branch.
2. Advisory and control system – During the operation, diagnostic image from various sources (data base, diagnostic device) can be called by surgeon and superimposed on real operating image to localise the optimal place for CABG connection. Also the simulated or real taken from previous operation recorded in database effect of particular way of connection could be obtained.

The introduction of robots to cardiac surgery gave as the possibility of direct and practical use of surgery procedures simulation results to the robot information system.

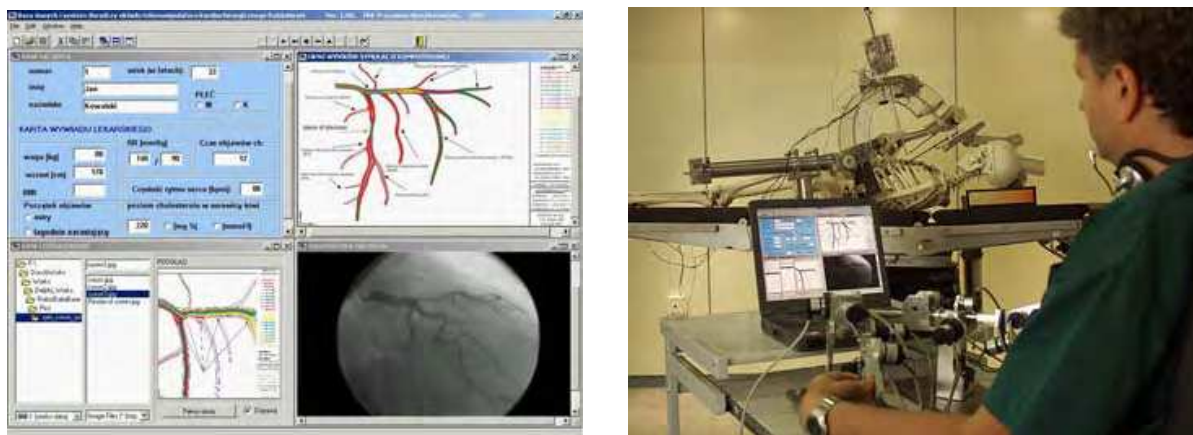

Figure 7. Intelligent voice control Database and Advisory System

3. Mechanical Construction of Robin Heart. Comparison with commercial surgery robots.

3.1 Robin Heart 0&1&2

Mechanics of existing cardiosurgical robots constructions consist of mechanical arm with replaceable laparoscopic tools specialised for different functions: cutting, sewing, removing of tissues etc. Introduced to the patient body tools can possess different number of degrees of freedom (DOF). Suitable number of DOF of tool wrist makes possible executing of different types of operation. In described constructions this as follows: in robot da Vinci (DV) bunch about diameter 8,5 mm possesses 3 DOF, in robot Zeus (Z) dependent on model: for diameter 3,9 mm we have 2 DOF, and for diameter 4,9 mm – 3 DOF. Both Robin Heart 0 and 1 (RH) has 4 DOF including additional joint for working backwards. In RH 0 diameter of tool carries out 10 mm, when in new RH1 already 8 mm. For RH 2 currently is performed simply 2 DOF tools, this model is dedicated especially as a base for endoscopic camera (Nawrat et al., 2003).

Second element of telemanipulator is the arm assure possibility of translocating of working ending of tool inside body of patient at maintenance of one constant point – passage through skin of patient body (so-called port). In described constructions two methods: kinematic passive of constant point creation in working space are applied. Passive method is modeled based on classic laparoscopy solution. Point of passage of tool through patient body (point of support of tool) treats itself how joint of 4 class - with 2 DOF. To fix all of 6 tool DOFs, the robot arm should have 4 DOF. Three of them are achieved by positioning of the external end of the tool. In the Zeus arm it is realized using SCARA type of manipulator construction. To obtain proper maneuverability it is necessary to use two not driven joints (kind of Cardan universal joint) in the place of connection of robot arm with the tool. Next DOF responsible for turning of the tool in relation to its axis is usually driven by motor. The disadvantage of this solution is loading of tissue near the port as a result of tools support during action. Flexibility of tool grows up also. In summary, the Z arms possesses 3 DOF which together with tools DOF gives us 5 or 6 DOF, depending on kind of the tool used. In telemanipulator DV, RH0, RH1 and RH2 for realization the constant point condition of work kinematics solution was used. In robot DV entire number of degrees of freedom carries out 6 DOF. In RH0, RH1 this is 7 DOF because of tool with one additional joint. Separate problem is range of arm movement what, in some situations, can limit possibilities of robot usage. Parallelogram mechanism of RH1 work correctly in range to 120° , in RH 0 range of movement is 150° (Nawrat et al., 2003).

The next important problem is a power transmission into tools. In presented constructions it is realized using strings or followers. In DV each of DOF is driven via strings. Range of movement of individual joints of tool is considerable – usually $\pm 90^\circ$ for every joint. Strings pass through rollers along whole arm of telemanipulator. Motors are placed on base, what in considerable degree discharge construction of arm. Due to considerable length of thin lines and its extensions the continuous inspection and trickery before every operation is required. If strings breaks, arm is not useful for further manipulation, what is disadvantage of this type construction.

Used in Zeus robot follover type of transmission has limited possibilities of drive of large number of successive degrees of freedom. Fundamentally two movements can be obtained: pitch of tool and its closing or opening. Strongly limited is also range of movement: $\pm 40^\circ$ for pitch and 20° for opening of tool. It possesses however some undeniable advantages: small diameter of tool (3.9 of mm) and high reliability.

In preliminary prototype RH0 string drive were used, similarly to DV, however for not so long sections. The strings are only 40 cm. Because endoscopic tool part is separable, eventually their breaking down of driven strings does not cause immobilizing of robot. The change of tool on new one will permit to finish operations with robot. The increase of mechanical properties and durability of this element was reached in RH 1. In this model the hybrid drive, follower - strings are applicated. The longest of strings were shortened to about 10 cm.

New compact construction of arm together with smaller motors is the reason, that the new arms are lighter and occupy smaller area above operating field. The most space occupies robot DV, in which 3 settled arms are on common massive column (Nawrat et al., 2003).

3.2 Robin Heart Vision for endoscope holding.

Mechanical construction of RH Vision (Fig. 8) is based on the prototype surgery telemanipulator Robin Heart, especially Robin Heart 1, developed and tested in FCSD between 2000-2005 (Fig.1).

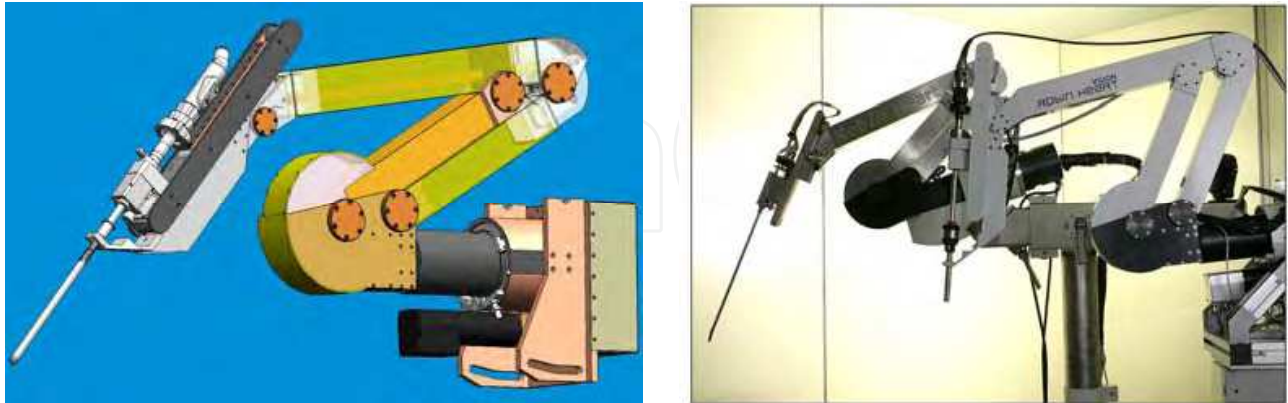

Figure 8. The Model of Robin Heart Vision (a) and the picture of real arm RHVision in the foreground together with Robin Heart prototype in background (b).

Its construction and driven system is an effect of modification of previous models based on their examinations. The main difference is the replacing of the AC motor with harmonic gear used for DOF_1 in RH0&RH1 systems with the electric, brushless motor integrated with planetary gear. The second (range up to 120 degrees doubled system of parallel mechanisms) and third DOFs (the parallel mechanisms eliminates the necessity of using a linear slideway) are driven by brushless motors, roller screws and system of strings. All four DOFs uses Maxon® DCBL motors with hall sensors and digital encoders as a control loop position sensor. The construction makes possible fast and not complicated disconnection the drive part of the bunch from the manipulating part (Nawrat & Kostka, 2007).

4. Control System of Robin Heart Tele-manipulator

4.1 General assumptions of Robin Heart telemanipulator control system

The main idea of control system is common for all described cardio-surgical systems (including Zeus and daVinci systems). The main task of Master-Slave teleoperator is reliable mapping of surgeon hand movements (setting of position/velocity/acceleration of other physical quantity) onto the movements of tool arm, through calculation of control signals for its motors.

Technical requirements of Robin Heart surgical tele-manipulator control system could be listed below:

- frequency of updating signals in the main control loop for translating the Master arm commands into the Slave arm movements, which ensures fluent work should be at least 1000 [Hz],
- satisfactory precision of surgery procedures, taking into account the small sizes of anatomical objects (e.g. 1 mm diameter of coronary vessels) should be guaranteed by the positioning accuracy and resolution equals at least 0.1 [mm],
- delay between Master and Slave arm movement should be lower than acceptable limit : $T_{DEL_MIN} < 100 [ms]$

- possibility of scaling the movements between the operator and the arm with surgical tool,
- an introduction apart from position surgeon commands (by means of master arm) also other forms of communication with system (e.g. voice control), to increase the comfort of the user interface,
- elimination of surgeon hands tremor,
- optional possibility of the “mirror” movements effects reduction.
- Hardware and software movement limit detection on particular axis
- Communication with host computer (RS, Ethernet) to change work parameters and monitor current state of the system
- Optionally, introduction of force feedback with the possibility of scaling of the force (or others: audio-visual, termical or mechanical - vibrations) sense, passing to operator.
- Optionally, software implementation of movement sets, realizing base surgery procedures in semi-automatic mode (commanded and supervised by surgeon) is planned.

A few different concepts of hardware and software were analyzed to obtain the best result: a system easy to develop and debug, and reliable during normal operation. Two technical solutions were designed, developed and put into practice during the project realization:

System based on VME bus and specialized cards for motor control (PEP® Modular Computers, OS9) (Nawrat et al., 2003).

Systems of regulators working in net, base on DSP and microcontrollers specialized for motor control – this type of hardware/software solution were also applied in Zeus and daVinci system.

4.2 Control System Implementation based on VME bus (RH0&RH1).

A specialised computer system based on VME (VersaModule Eurocard) bus, employing Motorola processor on the main board and working under real time operating system OS-9 was built. VMEbus is widely used in industrial, commercial, medical and military applications with over 300 manufacturers of products worldwide. The proposed control system has a few very important features:

- modular structure,
- industrial mechanical (19” wide and 3U high case) and electrical standard,
- wide range of specialized measurement, communication and control cards,
- open and scalable structure of hardware and software,
- real time operating system working on target controller and comfortable development software working on MS Windows platform.

Fast serial communication has been employed for synchronization and collision avoidance of three arms of robot. The main processor card VM62 based on Motorola MC68060 microprocessor communicates with other measurement and control cards through VME bus and with PC computer through Ethernet link. Specialized position control cards (VIMC) realize the low level regulation of drives with feedback provided by incremental encoders. Quadrature counters (CNT2) and D/A and A/D converters are used to connect haptic device described in the previous section (Nawrat et al., 2003).

4.3 Control System Solution based on Specialized Digital Signal Processors – DSP (RH2).

4.4 Robin Heart 2 solution.

Due to huge technological progress in microcontrollers and microprocessors in last years, units with very high computational power as well as with peripheral specialized for motor control accessible on the market, were used to create telemanipulator control system. Digital Signal Processor (DSP) (tested solutions: Sharc ADSP-2106x Analog Device® oraz TMS 320xxx Texas Instruments®, dsPIC family, Microchip®, ARM uC) is the heart of the system, which performs the task connected with kinematics computation and task sharing / synchronization. Set of N (number of motors) – control units, consisted of PID regulator (specialized microcontroller PIC® Microchip®), optional 10-12 bit D/A converter and power driver, realize the control commands of particular motor.

The surgeon tool is connected to the system through the set of M interface modules, sending information from sensors activated by surgeon hands.

Thanks to assumed hardware solutions control system can be flexible, easy prepared for development and improvement and relatively low cost.

In system Zeus endovision camera is steered by voice (AESOP), while in robot DV foot clutch permits interchangeable starting of camera or tools onto using. In Vinci system electronic control system consist of 4 DSP gives the computational power of 250 millions' floatingpointing operation per second (250 Mflops) and 300 million of operation for second execute to inspect movement of 48 engines with sampling frequency $f_s = 1500$ [Hz] (<http://www.intusurg.com>) exactly. Calibrating of movement is to 5:1, often it complies 3:1. Filter of palm tremble removing in DV is typical set on 6 [Hz]. In our system RobInHeart, we test arrangement of limitation now on level 10 Hz.

4.5 Robin Heart Vision solution.

Control system of RHV system for reading and processing the data from Master tool must create the output signals for set driving motor (Maxon DCBL motors, EC&ECPowerMax family), which drivers net has a distributed structure. Every motor unit assigned to particular DOF has its control PID unit with very advanced communication and safety systems (EPOS®, Maxon) placed next to it. All driver units are connected in serial CAN bus. Mentioned above assumptions were fulfilled in implemented control system based on digital signal processor (DSP) specialized for motor control, working as central unit. Main parts of Robin Heart Vision control system are following:

Master tool interface. Depending of type of Master tool (see below) signals from digital encoder sensors (A,B,I) or analogue voltage output (anal. gyroscopes) are translated to common, universal SPI serial bus. In case of Master tools cooperating with PC (joystick and voice recognition system) USB bus is used as a communication channel to system

Central unit. Input signals acquired and translated from Master tool are processed, where several control algorithms are implemented:

- forward kinematics of Master tool
- options: scaling, tremour removing, others
- inverse kinematics of Slave arm

Communication unit. Control system is an autonomous module working in real time system. Communication with host industrial PC realized by USB or Ethernet protocol is applied only for system parameter changing and monitoring (Nawrat & Kostka, 2007).

5. Tests for Robin Heart examination and evaluation.

The main idea of various tests started from first Robin Heart 0 prototype arm is to reveal potential weak points both of construction and control system to correct it and improve in the next model. The goal of surgery robot testing program is evaluation of whole system efficiency. Some parts of Robin Heart testing procedure include classical examination of telemanipulators with additional requirements for medical devices (Fig.9). After preliminary tests and elimination of mechanical and control defects we are preparing to perform tests on animals in condition of operational room and as a last step clinical application is planned.



Figure 9. The testing and measurement stands.

On the initial stage of mechanical system assumptions the analysis of maximal forces needed for standard surgery procedures was performed. During tests carried out by means of dynamometric stand on fresh pig hearts from basic surgery actions like:

- sewing
- cutting
- knot tying

The maximal force (18 N) was applied in case of scalpel cutting. Based on these results the load for robot arm tool tip was designed.

For the robot tests standardization, we tried to replace the operation on real tissues into actions into simulation environment, which consist of electromechanical system, which is able to create load conditions in the range and dynamics of natural material. The control system for this sophisticated testing stand is built based on analysis of real data and modeling the interactions which appear during surgery. Currently we test this system for 1 degree of freedom, but we plan to extend it to 3 D system in Cartesian coordinates.

The procedure of arm test is following:

- the tool tip is fixed to the modeled object (during crash tests only touch)
- definition of tested object character (e.g. aorta) by choosing appropriate procedure
- definition of robot task
- the analysis of test results

Thanks to this procedure we are able to compare robots and their particular parts (mechanics, control system, force feedback) in repeatable, standardize tests.

For different testing procedures several testing stands and systems were created:

- environment for monitoring and recording the given (user handle), commanded for motor and real motor position/velocity/current
- stand for hysteresis and repeat tests for both arms (RH0&RH1)
- external trajectory measurement for verification of theoretical settings.
- the usage of technological top semiconductor accelerometer and gyroscope sensors for acceleration and angle velocity measurements opened the new field of robot dynamic properties study. It allowed to record temporal velocity and acceleration values and to analyze and evaluate many phenomena's like e.g. vibration propagation with its frequency domain spectral analysis, angular movements (after integration of input signals)

5. 1 Tests of Robin Heart 0&1&2 systems

Mechanical system examinations.

Mechanical tests included:

- study of the arm stiffness with tool mounted
- repeat tests of tool tip positioning for chosen directions
- measurements of forces between tool tip and surrounding tissues
- tests of tool tip velocity for different movement directions
- tests of absolute accuracy of tool tip positioning in the coordinates of arm base
- hysteresis tests of tool tip positioning

Practically verified resolution of tool tip for every directions is ± 0.02 mm. The accuracy of operator tool trajectory mapping is about 0.3 mm. Preliminary examinations showed the mechanical hysteresis equal 0.03 mm (for RH1) and 0.02 (for RH2). Stiffness coefficient in this configuration was about $4.85 \cdot 10^3$ N/m (RH0), $2.86 \cdot 10^4$ N/m (RH1) and $5.5 \cdot 10^3$ N/m (RH2).

Tests of control and driving systems.

During test phase of project realisation following basic preliminary assumptions were positively verified:

- basic function of telemanipulator like mapping of user interface tool movements into arms movements with such options like scaling and low pass filtering was implemented and tested (Fig.10).

Tests of control systems computational efficiency acknowledged the algorithm sampling frequency F_s equal or above the 1 kHz. ($T_s \leq 1\text{ms}$):

- $F_s = 1\text{kHz}$ for Robin 0&1
- $F_s = 1.4\text{ kHz}$ for Robin 2 robot.

Trajectories of user handle and motor

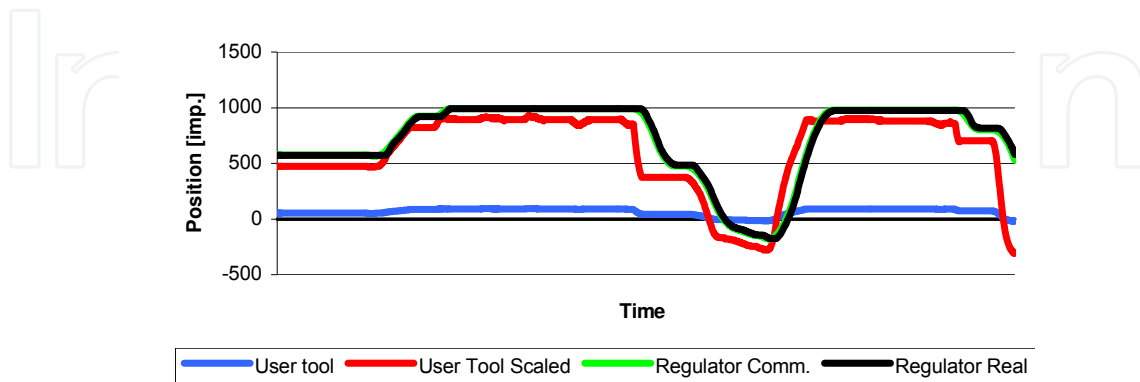

Figure 10. Trajectory of operator handle (original and scaled) and trajectory of corresponding motor (commanded and real). Movement scaling as well as the effect of low pass filtering (trajectory smoothing)

Analysis by means of technological top semiconductor accelerometer and gyroscope sensors for acceleration and angle velocity measurements.

These new sensor opened the new field of robot dynamic properties study. It allowed to observe and evaluate many phenomena's like e.g. vibration propagation with its frequency domain spectral analysis, which allowed to find the maximum vibration at frequency equal to 5 [Hz] for RH0 and more advanced analysis carried out for RH1, where gyroscope and accelerometer signal processing results are presented on time-frequency plane correlated with motor trajectory Time-frequency plane of vibration energy distribution allows to observe the spectral components with its localization also in time domain (Fig.11).

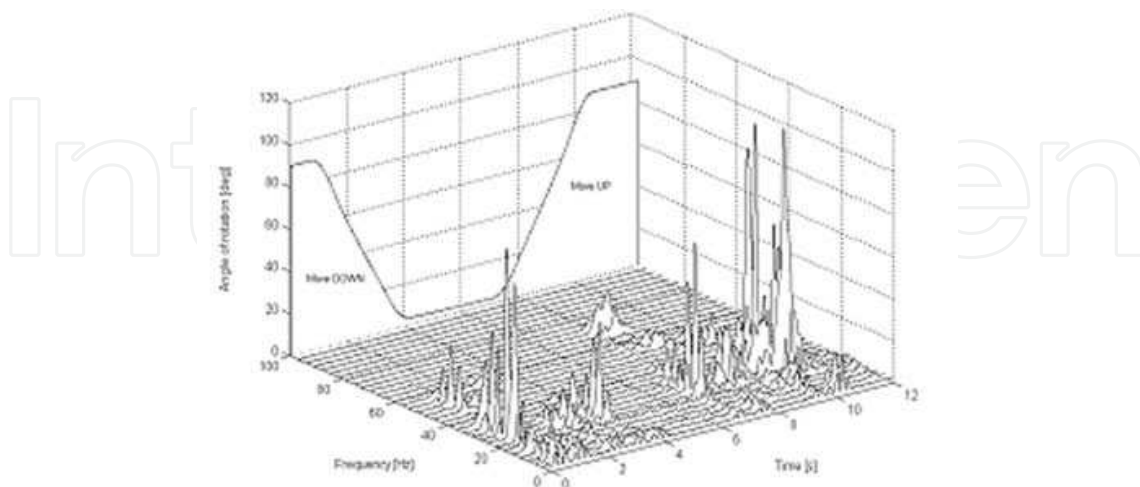

Figure 11. Results of Time-Frequency analysis of gyroscope sensors signals recording during 2nd DOF of Robin Heart 1 up and down movement. Main vibration moved toward higher frequencies (20-35 Hz) can be observed in acceleration and deceleration phase of trapezoidal trajectory. 3D time-frequency distribution

Summary of RH0&RH1&RH2 test results.

Test type / Parameter	RobIn Heart 0 (RH0)	RobIn Heart 1 (RH1)	RobInHeart 2 (RH2)
Arm stiffness coefficient [N/m]	4.85 * 10 ³	2.86 * 10 ³	5.50 * 10 ³
Mechanical hystheresis	-	0.03	0.02
Main control loop refresh frequency [Hz]	1000	1000	1400
Max. vibration amplitude on tool tip [mm]	4	1	0.5
Frequency range of vibrations [Hz]	4-6	20 - 35	30-35

Table 1. Chosen, the most important test results for RobIn Heart systems family.

5.2 Examinations of Robin Heart Vision System.

Basic tests for project assumptions verification.

Technical evaluation of Robin Heart Vision by means of digital micrometer fixed to prepared testing stand.

Verification of the movement range for particular DOFs:

Range of movement	DOF1 [deg]	DOF2 [deg]	DOF3 [mm]	DOF4 [deg]
	187	117,5	Effect. range :165 Max. range :400	350

The assessment of arm positioning resolution:

	DOF1 [mm]	DOF2 [mm]	DOF3 [mm]	DOF4 [mm]
Resolution	0.2	0.2	0.1	0.1

The test of arm precision during the repeat test - registration of the real external trajectory for every of n=100 constant position movements.

	DOF1	DOF2	DOF3	DOF4
Max [mm]	12,486	8,672	9,844	3,157
Min [mm]	12,466	8,625	9,791	3,024
Mean [mm]	12,473	8,668	9,820	3,109
Std. dev. [mm]	0,0054	0,0075	0,013	0,021

Histheresis test

Consecutive *n* movements with incremented (1.phase) and decremented (2.phase) commanded position (*x_i*) during “forward” and “backward” phases (1):

$$x_i = x_0 + i * step ; i = \{1..n..1\} ; x_0, step \in Z \tag{1}$$

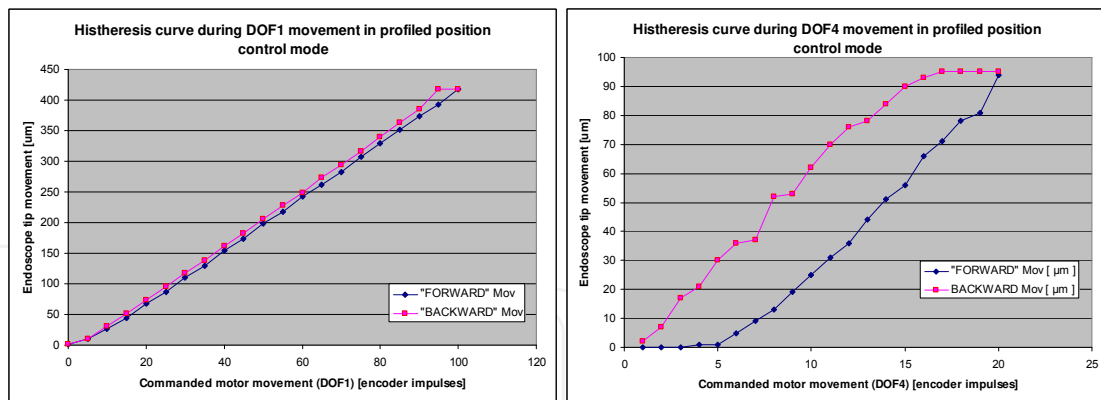

Figure 12. Results of histheresis tests for chosen DOFs: DOF1 & DOF4 (Nawrat & Kostka, 2007).

Visualization tests

The goal of this group of tests is to measure robot performance by objective real, external trajectory measurement by means of specialized image recording and analysis method.

The measuring system consists of:

- two digital cameras A602fc-2 Basler 100 [Hz];
- computer with motion analysis system APAS;
- set of reflective markers stuck on tested object;
- two sources of light;
- calibration cube.

System of three digital cameras synchronize record the movement of robotic system with special markers fixed to its characteristic points (mainly joints and linear movement parts) (fig.6). Trajectories recorded from different cameras are combined and analyzed in specific image analysis software to compute real external trajectory of robot arm.

Synchronize recording of 'Slave' arm movements, reflecting operator command movement using head movement interface was also performed and trajectories for both 'Master' and 'Slave' tools are presented (Fig.9).

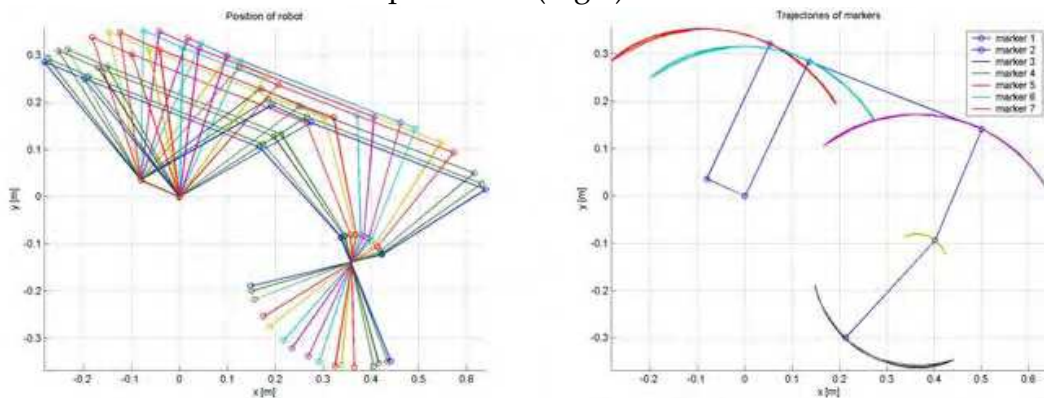

Figure 13. Positions of markers at the following moments of time (Michnik et al 2007)

The motions of reflective markers puted on: upper limb of surgeon, laparoscope master tool manipulator, robot arm (in axes of rotationat kinematic pairs) and operation tool were recorded by two cameras. The movies were transmitted to laptop through video

card. After synchronization of movies from two cameras in Digitize module of the APAS system, the kinematic analyses were performed (Michnik et al., 2007)

The Apas system allows to determine automatically trajectories of markers. Linear displacements, velocities and accelerations of markers as well as angular displacements, velocities and accelerations of individual segments of robot arm (Fig.13), upper limb of surgeon, laparoscope master tool manipulator LMTM (angular and linear) and operation tool were obtained in this way.

The results enable verification of three values, which have a significant influence on MASTER-SLAVE systems:

values of determined delays T between motions of MASTER and SLAVE parts;

coefficients of scale of displacements k ;

mapping of adequate motions between laparoscope master tool manipulator (LMTM) and robot arm with operating tool.

Experimental scientific research and kinematics' analysis were performed for motions of robot in three degrees of freedom:

1 DOF - angular motion of SLAVE around axis of 1 DOF;

2 DOF - angular motion of SLAVE around axis of 2 DOF;

3 DOF - linear motion of operating tool ;

Modal examination by means of PCB accelerometers.

To verify the correctness of surgical robot supporting structure, a detailed modal examination was performed and the result data was analyzed. Experiment examination was performed as a first step to compare a different version of surgical prototype structure. The received data was used to estimate a natural frequencies of different robot constructions and to obtain a vibroacoustic signal shape from acceleration sensors during a programmed robot move. Stability of an analyzed system was verified in aspect to find the most unsafe robot position which might lead to loose a movement accuracy. This type of knowledge will be necessary in planning a surgery procedure choreography and a Robin Heart position in reference to a surgery table.

Measuring set consists of (Kozlak et al., 2007):

- Signals analyser: SigLab 20-42 DSPT Technology,
- One axis accelerometer sensor: 333B31 made by PCB,
- Modal hammer symbol 086C20, with the force sensor, range: 1 kHz,
- PC + Matlab\SigLab\Vioma software.

As a result in the frequency range up to 500 [Hz], based on stabilizing diagram 12 frequencies of self vibrations were identified for the chosen robot arm position. For example for DOF2 (in max angle) the lowest frequency = 15.3 [Hz] was observed with the 41% smoother, next 58 [Hz] with the smoother 9.3% (Kozlak et al., 2007).

The animal experiment exam

The last pre-clinical robot examination will be the animal test performed in the specific conditions of operation room. At the end of 2003 our team received the Permission from the Ethics Committee of Silesian Medical Academy to perform the first series of in vivo experiments of Robin Heart.

The first stage of tests will include following surgery procedures:

- Robot assisted surgery in abdominal cavity (ganalectomy , bladder excision)
- Bypass implantation on beating heart by means of surgery robot

- Extracorporeal circulatory procedure using Robin Heart (artificial heart valve replacement)

In near future after specialized tools preparation, the operation of ventricular assist device implantation by means of Robin Heart is planned.

7. Conclusion

Currently there are two different robotic systems designed for a cardiac surgery: clinically working daVinci® offered by Intuitive Surgical (since 1998) and a Polish prototype Robin Heart (RH). Both daVinci and the Robin Heart systems are computer-controlled tools, located between surgeon's hands and the tip of a surgical instrument. Polish system named Robin Heart was constructed as a result of work on several prototypes. The project was carried out by a wide area of specialist (Technical Universities from Lodz, Warszawa, Gliwice) under the leadership of Foundation for Cardiac Surgery Development (FCSD) in Zabrze. Launching of the first clinical Robin Heart application is planned by 2009.

Endoscopic microsurgery is difficult to perform with standard hand held instruments but till now robotically assisted did not solve all the problems. In most surgery procedures assisted by robots, only part of these kind of operation are carried out using robot. In this connection the strategy of RH project plans to prepare the family of robotic or semi-automatic surgical tools, which usage could be planned according to required functionality. RH clients will be able to choose both Master tool interface and expert system efficient and comfortable for them. The surgery planning can be carried out using 3D virtual operation room.

Efficiency of using a robotic equipment in an endoscope procedures significantly depends both on a proper tools geometry optimization and a correct surgery procedure planning. Accurate arrangement of setting up the robots arm with reference to an surgery table, positioning the trocars location in a patient body and right choice of a correct tools, makes the surgery procedure much more safe and harmless. Using a virtual reality technology to plan all those important steps, increases efficacy of a noninvasive surgery methods and helps to verify a benefits of using robotic systems in a various surgery treatment.

The FCSD future plans include to carry out the robotically assisted less invasive procedures to implant pumps and valve and mini-invasive service of temporary applicated artificial organs (AORobAS project). In our team the first work on the assumption for heart pump and valve special for robot & MIS (Minimally invasive Surgery) application is done and special tools of robot is constructed.

Efficiency and development of robots usage fields requires searching for the most optimal cardiac robots application range, building the strategy of its usage, simulation the operation results issue and creating the knowledge base supporting the robot's arm navigation and cardiac surgeon decision making, studying of image processing methods for optimal robot's arm navigation

The education and training influences the achievement of success. Next point is cost effectiveness. Currently used robot is too expensive. The investment and maintenance costs still represent the major problem of the da Vinci robot working in about 300 hospitals worldwide. Due to the high cost several clients resigned from continuing robotically assisted practice. To make robotically-assisted surgery wider acceptable the

operation have to be more easier and more attractive for the end user - surgeon (new tools, pre-planning, advisory system) and less expensive for hospital owner. The lack of rapid improvement and the time consuming procedure led to frustration and many centers did not proceed. We hope that the family robots Robin Heart is good answer for this postulate and create alternative opportunity for currently used technology.

To summarize the current state of polish Robin Heart project realization we can state, that several prototypes of Robin Heart robot for usage in cardiac surgery has been prepared both surgery tool arms as well as RH Vision for camera channel holding. The development of simulation methods for advisory system was reached. The research included:

- strategy planning
- on-line control
- expert and advisory systems for cardiac surgery robot.

We plan that our robot will be more friendly for surgeon, as well as more safety for patient. Our activity in this subject is directed towards two sides: voice control advisory system and interface system.

We plane the first animal test of our robot in autumn of 2007. The first clinical application of endocamera Robin Heart Vision robotically controlled in 2009, the first operation performed by Robin Heart in 2011.

To summarize, on this stage of project realisation the multidisciplinary team was set up, many students and young researches were included and the construction works go according to plan.

8. Acknowledgement

The research is supported by State Committee for Scientific Research (KBN 8 T11E 001 18) and Foundation of Cardiac Surgery Development. Warmly thank we fold workers KBN and sponsors for engagement into our project, our numerous collaborators: L.Podśędkowski, K.Mianowski, Z.Małota & Z.Religa and considerable group of students of some universities, which wrote qualifying works, graduate and participated in occupations of scientific wheel.

9. References

- Jacobs, S., Falk, V., Holzhey, D., Mohr, F.W. (2006), Perspectives in endoscopic cardiac surgery. *Comp. Biol. Med.* (2006), doi: 10.1016/j.combiomed.2006.11.007
- Kozlak, M., Myk, A., Kciuk, S., (2007), Analiza drgań prototypu robota medycznego Robin Heart. XV KBiB (*Biocybernetics and Bioengineering Conference*), Wroclaw, September 2007, Proceedings in press,
- Michnik, R., Ilewicz, G., Jurkojć, J., Tejszerska, D., Nawrat, Z., (2007) Controlling of the operating tool displacement of Master-Slave system of cardiosurgical telemanipulator. *Modelling and Optimization of Physical Systems 6, Zeszyty Naukowe Katedry Mechaniki Stosowanej*, no 6, pp.117-122, Gliwice 2007 Wydawnictwo Katedry Mechaniki Stosowanej, ISBN 9788360102266
- Nawrat, Z., Podśędkowski, L., Mianowski; K., Kostka, P., Wróblewski, P., Małota, Z. (2003) Robin Heart - Actual project state of polish telemanipulator dedicated

for cardiac surgery. *The Journal of Artificial Organs*. Vol 26/no.12,2003/pp.1115-1119

Nawrat. Z, Kostka, P.,(2007) The Robin Heart Vision, telemanipulator for camera holding preliminary test results. *Journal of Automation, Mobile Robotics & Intelligent Systems, volume1, No. 1, April 2007, str.48-53*

IntechOpen

IntechOpen



Medical Robotics

Edited by Vanja Bozovic

ISBN 978-3-902613-18-9

Hard cover, 526 pages

Publisher I-Tech Education and Publishing

Published online 01, January, 2008

Published in print edition January, 2008

The first generation of surgical robots are already being installed in a number of operating rooms around the world. Robotics is being introduced to medicine because it allows for unprecedented control and precision of surgical instruments in minimally invasive procedures. So far, robots have been used to position an endoscope, perform gallbladder surgery and correct gastroesophageal reflux and heartburn. The ultimate goal of the robotic surgery field is to design a robot that can be used to perform closed-chest, beating-heart surgery. The use of robotics in surgery will expand over the next decades without any doubt. Minimally Invasive Surgery (MIS) is a revolutionary approach in surgery. In MIS, the operation is performed with instruments and viewing equipment inserted into the body through small incisions created by the surgeon, in contrast to open surgery with large incisions. This minimizes surgical trauma and damage to healthy tissue, resulting in shorter patient recovery time. The aim of this book is to provide an overview of the state-of-art, to present new ideas, original results and practical experiences in this expanding area. Nevertheless, many chapters in the book concern advanced research on this growing area. The book provides critical analysis of clinical trials, assessment of the benefits and risks of the application of these technologies. This book is certainly a small sample of the research activity on Medical Robotics going on around the globe as you read it, but it surely covers a good deal of what has been done in the field recently, and as such it works as a valuable source for researchers interested in the involved subjects, whether they are currently “medical roboticists” or not.

How to reference

In order to correctly reference this scholarly work, feel free to copy and paste the following:

Zbigniew Nawrat and Pawel Kostka (2008). Robin Heart - Perspectives of Application of Mini Invasive Tools in Cardiac Surgery, Medical Robotics, Vanja Bozovic (Ed.), ISBN: 978-3-902613-18-9, InTech, Available from: http://www.intechopen.com/books/medical_robotics/robin_heart_-_perspectives_of_application_of_mini_invasive_tools_in_cardiac_surgery

INTECH
open science | open minds

InTech Europe

University Campus STeP Ri
Slavka Krautzeka 83/A
51000 Rijeka, Croatia

InTech China

Unit 405, Office Block, Hotel Equatorial Shanghai
No.65, Yan An Road (West), Shanghai, 200040, China
中国上海市延安西路65号上海国际贵都大饭店办公楼405单元

Phone: +385 (51) 770 447
Fax: +385 (51) 686 166
www.intechopen.com

Phone: +86-21-62489820
Fax: +86-21-62489821

IntechOpen

IntechOpen

© 2008 The Author(s). Licensee IntechOpen. This chapter is distributed under the terms of the [Creative Commons Attribution-NonCommercial-ShareAlike-3.0 License](#), which permits use, distribution and reproduction for non-commercial purposes, provided the original is properly cited and derivative works building on this content are distributed under the same license.

IntechOpen

IntechOpen