

# We are IntechOpen, the world's leading publisher of Open Access books Built by scientists, for scientists

**4,800**

Open access books available

**122,000**

International authors and editors

**135M**

Downloads

Our authors are among the

**154**

Countries delivered to

**TOP 1%**

most cited scientists

**12.2%**

Contributors from top 500 universities



**WEB OF SCIENCE™**

Selection of our books indexed in the Book Citation Index  
in Web of Science™ Core Collection (BKCI)

Interested in publishing with us?  
Contact [book.department@intechopen.com](mailto:book.department@intechopen.com)

Numbers displayed above are based on latest data collected.

For more information visit [www.intechopen.com](http://www.intechopen.com)



## Robotic Long Bone Fracture Reduction

A. E. Graham<sup>1</sup>, S. Q. Xie<sup>1</sup>, K. C. Aw<sup>1</sup>, W. L. Xu<sup>2</sup> and S. Mukherjee<sup>3</sup>  
<sup>1</sup>The University of Auckland, <sup>2</sup>Massey University, <sup>3</sup>Palmerston North Hospital  
 New Zealand

### 1. Introduction

Medical robotics is still a relatively new field with researchers and companies all adopting various styles and techniques to solve the challenges faced. This chapter outlines one unique approach to the development of a medical robot for the reduction of broken femurs.

Fractures are common injuries, for example in adults over the age of 65 it is reported that 87% of falls results in a fracture (Canale & Campbell, 2003). This has led to the development of focused trauma centers having the capability to quickly diagnose and respond with the appropriate treatment action and expertise. However, orthopedics as a discipline is relatively conservative with a large scope for improvement. Often techniques used are controversial and experience of the surgeon is limited as training is difficult. Historically the main drivers for improvements in the tools and methods used have been the large number of injuries during world wars. Development focus was on life and limb preservation while the technology has remained relatively constant. Now there is an opportunity with the increased advancement of technology to look at the processes and overcome problems that previously could not be addressed.

Orthopedics has been identified as particularly suitable for robotic applications as bones are relatively rigid structures and imaging techniques allow a computer to locate and register the location of bones. This has led to the implementation of new medical robotic technologies such as ISS Robodoc for total hip replacement (Kazanzides et al., 1992.) and Acrobot for knee replacement (Jakopec et al., 2003). These systems are commercially available and have been successful in improving the accuracy and overall outcome of surgery.

Investigation into long bone fracture reduction in particular has received attention by several groups. Gösling et al. (2005) and Westphal et al. (2006) developed a joystick tele-operated system using a serial robot and carried out preliminary user studies. They showed that the robotic system can achieve precise alignment and reduce intra-operative imaging. Maeda et al. (2005) and Warisawa et al. (2004) also used a serial robot and examined three control modes of manual jogging, power assist and automatic. Graham et al. (2006) previously described a conceptual fracture reduction system including procedure planning assistance and a parallel robot mechanism for reduction, this work is a further development of that.

In previous research work many problems are only partially understood and/or solved. For example radiation exposure, fatigue and problems in pre-operative planning remain. To properly determine the needs and focus direction of research it is useful to form the framework in Fig. 1. From this figure the main stakeholders are presented as system

Source: Medical Robotics, Book edited by Vanja Bozovic, ISBN 978-3-902613-18-9, pp.526, I-Tech Education and Publishing, Vienna, Austria

recipients, users and designers typically representing patients, surgeons and researchers respectively. Each of these stakeholders has different areas for improvements and these can be determined by considering drivers from both the hospital and technology. There are three main outcomes or goals established for fracture reduction; these are 1) to improve the knowledge of fracture reduction surgery 2) to improve the process used to reduce the fracture and 3) to improve the outcome of fracture reduction. From the figure these have respective technology drivers of databases, interfaces and robotics. Combined they produce a matrix of challenges to be solved and are discussed in the following paragraphs.

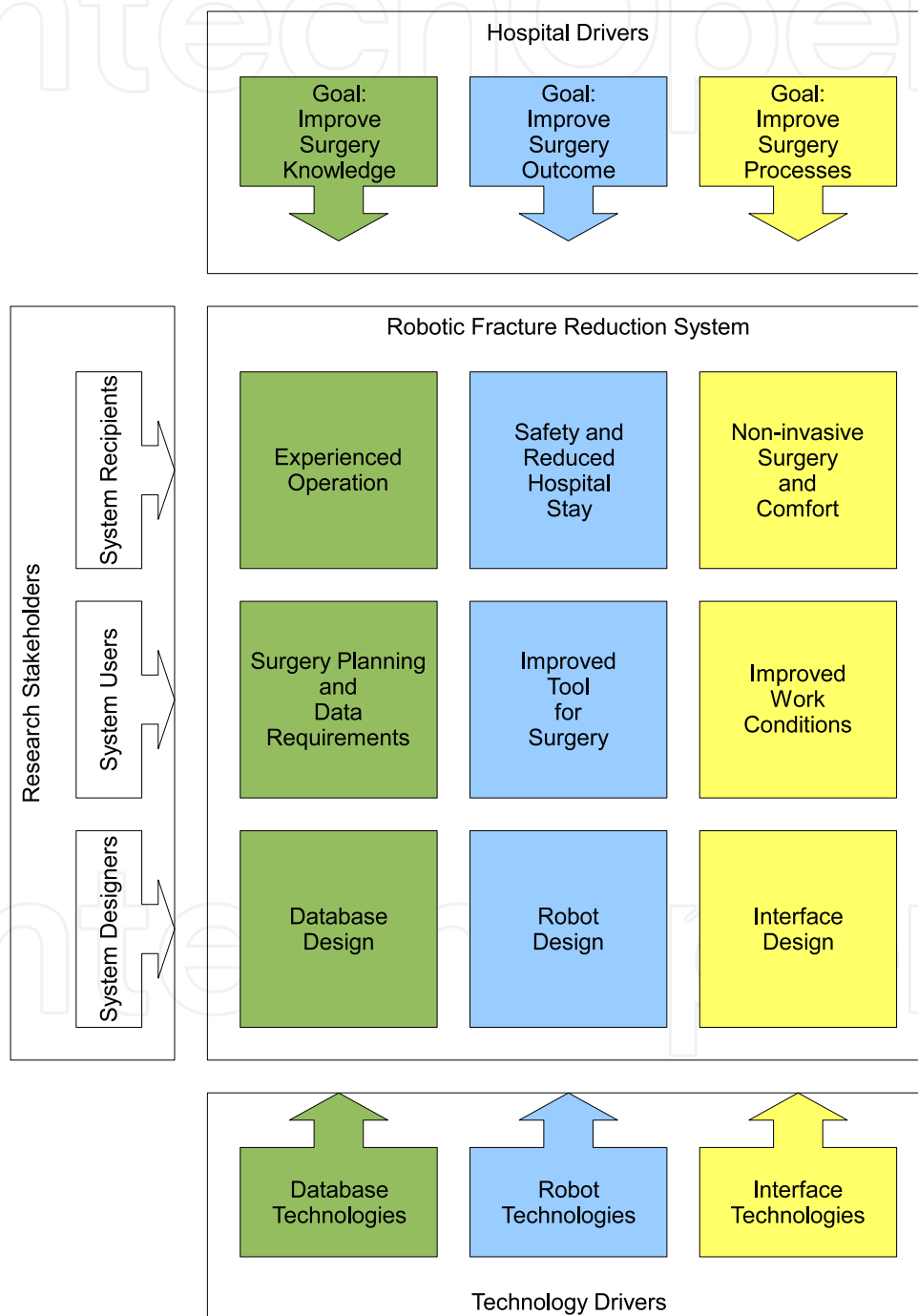

Figure 1. System stakeholders and drivers

If the needs of the recipients or patients are considered from Fig. 1. aims are to provide an experienced surgeon, maintain or increase the level of safety, reduce the length of hospital stays while providing non-invasive surgery and maintaining comfort. Currently training of new surgical staff for reduction procedures is difficult. Research has been undertaken to improve surgeon training and resource use through simulation (Sourina et al., 2007), however there still exists controversy around which existing solutions to apply. The result is that often long bone reductions are carried out by people with only a few previous examples to draw experience from. This leads to a discussion around surgery practices and outcomes which are not tracked in a concise and available format so it is difficult to see what is improving over time or to make comparisons between methods. Warisawa et al. (2004) and Graham et al. (2006) both suggested the need for gentle reduction. This has the potential to reduce trauma especially for elderly as the current manual reduction provides limited information about the internal problems that could be occurring. Gentle reduction also can lower the discomfort and pain experienced by the patient from the perineal post positioned between the groin to provide counter force for reduction. Replacing the manual control with a robotic device does raise safety questions for the patient and to solve this mechanical fuses have been used (Warisawa et al., 2004; Masamune et al., 2001) along with monitoring force in various forms to slow or prevent action (Davies et al. 2000; Ho et al., 1995; Taylor et al., 1994; Paul et al., 1992). Robot patient registration should be non-invasive and avoid the use of fiducials which can lead to patient discomfort (Howe & Matsuoka, 1999; Cinquin et al. 1995). Referring back to Fig. 1. again from the perspective of system users or the surgeon it is seen that there is a desire to improve the planning of surgery, have access to the correct data when needed and a better tool for carrying out the actual reduction. This needs to be addressed in a way that improves the existing problems with the operating room (OR) work environment. Planning surgery takes time requiring a physical examination and pre-operative x-rays which are difficult to interpret and visualize in a 3 dimensional (3-D) format. The outcome of the plan is generally based on hands-on experience and text book knowledge of the surgeon. The plan for reduction is currently executed with a manual reduction table and fluoroscope machine. Reduction can be problematic and statistics from Germany report 4111 patients are required to undergo corrective surgery from malrotation alone, requiring at least 7 additional days stay in hospital (Gösling et al., 2005). This can be attributed in part to the reduction table which is limiting in the degrees of freedom (DoF) and obtainable accuracies combined with mental strain from reconstructing images in 3-D. The manual traction interface to carry out the operation requires the surgeon to exert forces to counteract reduction which have been reported between 201 and 411 Newtons (Maeda et al., 2005; Gösling et al., 2006) and can lead to physical fatigue. Radiation reduction is a contributing motivator for a number of medical robotic research projects (Loser & Navab, 2000; Stoianovici et al., 2003; Cleary et al., 2002). In long bone reduction the same applies where the close proximity to the fluoroscope machine can have harmful effects on the surgeons health or effectively limit the number of operations they can carry out per year without an appropriate distancing tool (Skjeldal & Backe, 1987). Finally a concern for the broader user is resource (such as floor space and budgets) in the operating room which is usually limited and new developments in long bone reduction should appropriately consider this limitation in the design.

To address the problems listed in the previous two paragraphs this research has taken steps towards developing the driving technologies. Driving technologies are those that provide

solutions to the needs of users and recipients, ultimately achieving the three driving factors from the hospital. Specifically the robot technologies for a parallel fracture reduction device are being designed and prototyped. This will provide a new smart tool for the user addressing the issue of radiation exposure, physical fatigue and manipulation accuracies. It will also remain compact and integrate with existing hospital technologies. The underlying modeling and analysis is carried out to produce a tool for robot control development and identify appropriate data to be stored as a database to aid treatment planning pre-operatively and inter-operatively. Interface technologies allowing interaction between the user and robot are being developed for effective surgery to take place. The methods used to develop these technologies are discussed in section 2. This is followed description of the results obtained to date in section 3 and a discussion on what has been achieved in section 4. Finally section 5 presents the future work to be done.

## 2. Methods

This section provides details on the methods and tools used to develop the solutions to the driving technologies. This consists of the interface which includes visualizing the fracture, planning assistance and human-robot-interaction. The physical robot and control design methods are given followed by the database method, describing what is stored and the motivation behind it.

### 2.1 Interface: Visualization of the Fracture

The main problem to be addressed here is the visualization of the fracture. This has an impact on both the surgery process and also the method to perform pre-operative planning. Visualization is concerned with taking fluoroscopy images and presenting them to the surgeon in a useful form that can be easily interpreted. This is achieved by providing a 3-D view to the surgeon generated from only a small number of fluoroscope images that can be manipulated in real time. Fluoroscope images are used as opposed to detailed computer tomography (CT) often seen in medical robotics applications (Jakopec et al. 2003; Joskowicz et al. 1998; Kazanzides, 1992) as they are less resource intensive for the hospital, can be obtained inter-operatively and is the same imaging technology currently used for reduction. Previously concepts of fluoroscopy servoing have been presented using specially designed needles although for some applications it is found that the level of detail contained in an image is not sufficient (Cleary et al., 2002; Cleary et al., 2003; Loser & Navab, 2000). Other applications have aimed at using fluoroscope images to register nail insertion with pre-operative CT scans during closed medullary nailing in long bone surgery (Joskowicz et al., 1998) and similarly use the images obtained of the nail for robot guidance (Wang et al., 2004). The proposed approach in this research is to have a stored number of generic structures or bones and take a minimum number of fluoroscope images to match the appropriate model. Initial investigation into implementing matching of 2-Dimensional (2-D) images has been undertaken however the limiting contrast and soft tissue obstruction in fluoroscopy images still needs to be overcome. Currently the surgeon is required to manually match 22 points in two consecutive images (Rensburg et al., 2005).

After matching the femur, a 3-D view is displayed. This has the option to view the femur, fibula, tibia, sacrum, hip, patella, visible muscle and muscle attachment lines. 3-D models currently used are finite element meshes derived for the widely used Visible Human dataset

and are stored in the generic WRL file format, also known as VRML (virtual reality modeling language).

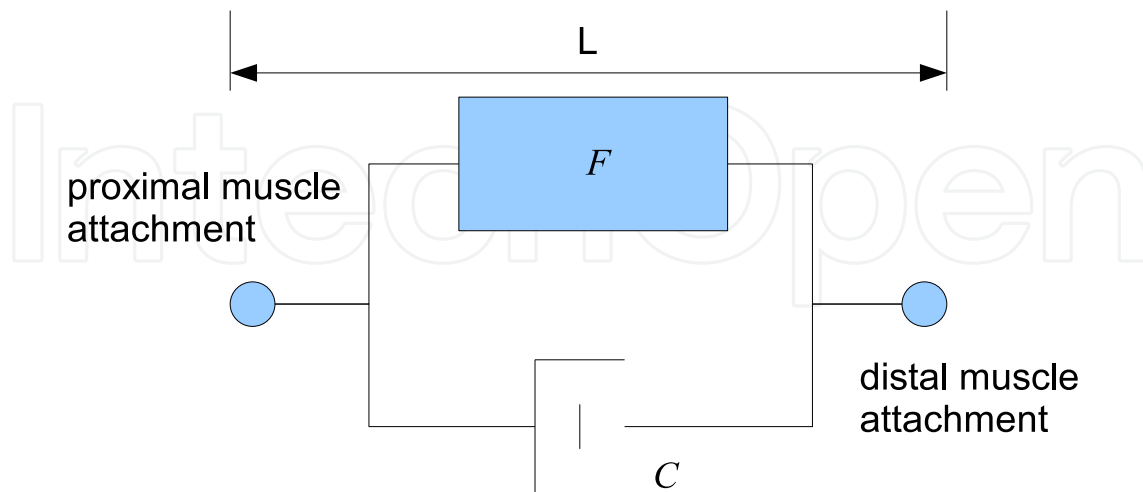

Figure 2. Structure of the Hill muscle model

### 2.2 Interface: Planning Assistance

To assist the surgeon in planning the operation a model is developed to estimate the expected force of each muscle. This will provide information intra-operatively about the expected internal state of the fracture and assist by presenting a planned reduction path based on minimal force exertion and position. The model also has further use in creating and understanding robot requirements and developing control of the robot mechanism as presented in section 2.4. In order to create the model the attachment location of visible muscle on the bone mesh is obtained for each muscle. The well established Hill type muscle model (Winters & Stark, 1985; Winters & Stark, 1988; Friederich & Brand, 1990) as in Fig. 2. is then used to determine the force by each muscle as given in Eqn. 1.

$$F = \frac{F_{\max}}{e^{sh} - 1} \left( s^{sh \Delta L / \Delta L_{\max}} - 1 \right) \quad (1)$$

where

$$F_{\max} = 0.5 \text{ MPa} \quad A_{pcs} = 0.5 \text{ MPa} \left[ \frac{m}{(2\rho y)} \right] \sin(2\alpha) \quad (2)$$

$$sh = 1.5 + 3 \times smf \quad (3)$$

and  $F$  is the force generated by the equivalent muscle spring element in Fig. 2.,  $sh$  is a shape parameter,  $\Delta L$  is the muscle extension,  $A_{pcs}$  is the physiological cross sectional area,  $m$  is the muscle mass,  $y$  is the thickness,  $\rho$  is the muscle density,  $\alpha$  is the muscle pennation angle,  $smf$  is the percentage of slow muscle fibers and  $\text{MPa}$  is Mega Pascal's. The spring element is modeled in parallel with a dash-pot having damping ratio,  $c$

The muscle models combined with the moving geometry of the distal fragment during reduction result in a system of equations in generalized coordinate  $q$ . This can be written in a state space form as Eqn. 4.

$$M_b(q)\ddot{q} + C_b(q, \dot{q})\dot{q} + G_b(q) = F_b + R_b \quad (4)$$

where  $M_b(q)$  is the mass matrix,  $C_b(q, \dot{q})$  are the velocity terms,  $G_b(q)$  terms due to gravity,  $F_b$  and  $R_b$  are the force produced by the muscles and external reaction force respectively.

### 2.3 Interface: Human-Robot-Interaction

The interface presented to the surgeon to control the robot plays an important role in the success of implementation. Robot psychologists suggest humans are increasingly accepting robots as co-workers and partners in tasks as opposed to a mechanical tool to be commanded (Libin & Libin, 2004). Incorporating a user into the control is done in one of four ways; by direct, supervisory, collaborative, or shared control (Bruemmer et al., 2005; Shen et al., 2004). These are typically discussed in relation to navigation through tele-operation of robotics, here they are applied to medical robotics. In direct or manual control the user directly commands what to do for all movement. For supervisory control the robot is still treated as a slave where the user makes higher level changes to the state of the controllers and monitors the status. Under collaborative control the user becomes a resource to the robot where both the robot and human share dialog to overcome difficulties. Lastly shared control puts the human as a virtual presence in the system and can result in more autonomy. Although there are many other definitions for control schemes such as adjustable autonomy (Goodrich et al., 2007), tele-operation with safeguard (Krotkov et al., 1996) and control with active constraint (Ho et al., 1995), the previously mentioned terminology will be used as they cover the range of implementations. Most robotic applications use a form of supervisory control where the robot will enact human commands with various levels of autonomy depending on the complexity of the task. Fong et al. (2006; 2003; 2001) have made many contributions on collaborative control which treats the robot as a partner and communication occurs through a set of semantic dialogues. Shared control is not suitable for long bone fracture reduction, however would find uses in applications such as heart surgery where sharing the operation tasks and decisions could allow treatment of a beating heart. Trusting the robot is important for a medical robot application. By allowing the robot to take initiatives and decide when not to follow user instruction and suggest improvements to users decision trust is gained. There will also be an increase in both safety and the outcome. To achieve this a collaborative control approach is used. Under the collaborative control scheme conversation needs to occur between the robot and human. Previously the authors have suggested the use of technologies such as voice or augmented reality to bring human qualities to the robot and allow the surgeons attention to remain on the operation (Graham et al., 2006). Such dialogue could include "I have planned a reduction path would you like to make corrections?", "ready to begin reduction, shall I proceed?" or "Force higher than expected, should I continue reduction?". This takes the best aspects of supervisory control with the robot following a plan specified by user understanding but allows the robot to make situation critical decisions.

## 2.4 Robot Design: Physical Description

The work envelop requirements and accuracies have been derived from consultation with OR staff and are given in Table 1, where  $x, y, z$  are defined as in Fig. 3. and  $\theta, \phi, \varphi$  are rotations about the axes respectively. The requirements reflect a desire to have 6 DoF when manipulating the fracture back into correct anatomical alignment. The unit needs to be compact so it doesn't take up too much valuable OR floor space and can be moved easily if needed. Remote operation should be allowed to move the surgeon away from the source of radiation exposure. The device should also have fail safe features to prevent unnecessary harm to the patient on an internal or external failure such as loss of power. As shown in Fig. 3. the current manual device has 3 DoF to globally locate the position of the leg, these are in region  $a_1$  consisting of joints  $\theta_1, d_1$  and  $d_2$ . Region  $a_2$  provides an additional 3 DoF used when performing the reduction.

Parameter	Range (mm/deg)	Accuracy (mm/deg)
$x$	$\pm 100$	$< 1$
$y$	$\pm 100$	$< 1$
$z$	$\pm 150$	$< 1$
$\theta$	$\pm 10$	$< 1$
$\phi$	$\pm 10$	$< 1$
$\varphi$	$\pm 30$	$< 1$

Table 1. Workspace requirements for fracture reduction

To replace the manual device a robotic parallel mechanism is selected. A computer model of the design is shown in Fig. 4. comprising of 6 powered links in parallel joining a base and top plate. The parallel structure can provide 6 DoF to correct the translation and malrotation and has a number of benefits over similar featured serial mechanisms. There is a high payload to weight ratio and a low moving mass meaning the device can be relatively small while still being able to counteract the deforming forces from muscles. Multiple closed loop chains increase stiffness and the linear actuators used often have a high gear ratio preventing any back driving. This adds to safety if there is a failure during the operation because the robot pose will remain held. Accuracy is high as error is averaged over the parallel links rather than accumulated as in a serial mechanism. A restricted work volume increases safety in an error state where the links cannot extend large amounts. Although this restricts the overall motion by maintaining the passive joints in region  $a_1$  from Fig. 3. the motion is more than sufficient. Similar approaches where a global localization system is used for a smaller, inherently safer devices can be seen in (Loser & Navab, 2000; Davies et al. 2000; Stoianovici et al. 2003; Cleary et al. 2002).



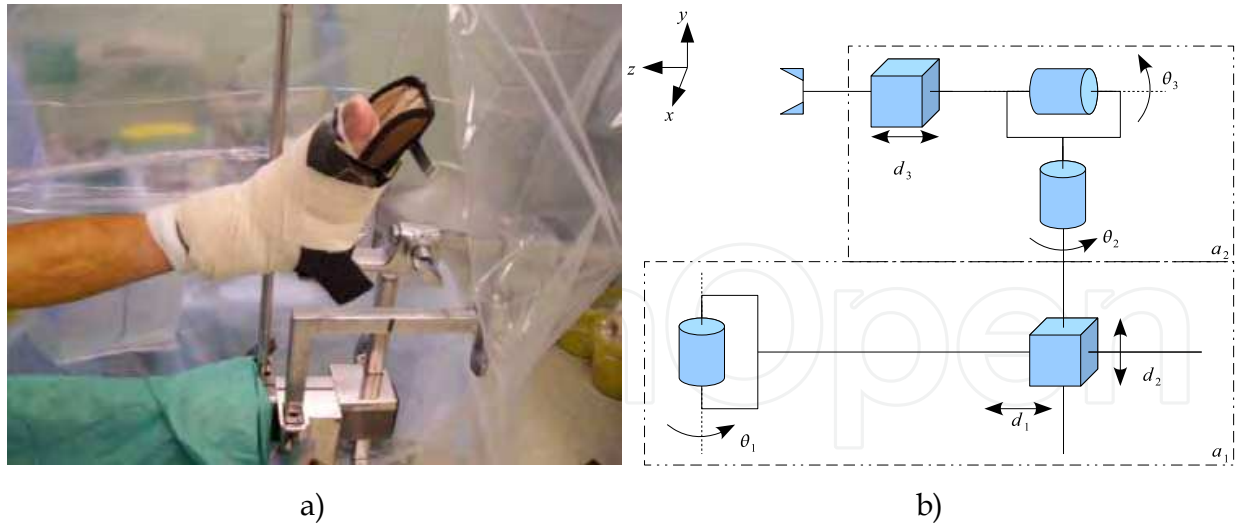

Figure 3. Existing manual reduction device attached to patients foot a) the actual manual device b) manual DoF diagram

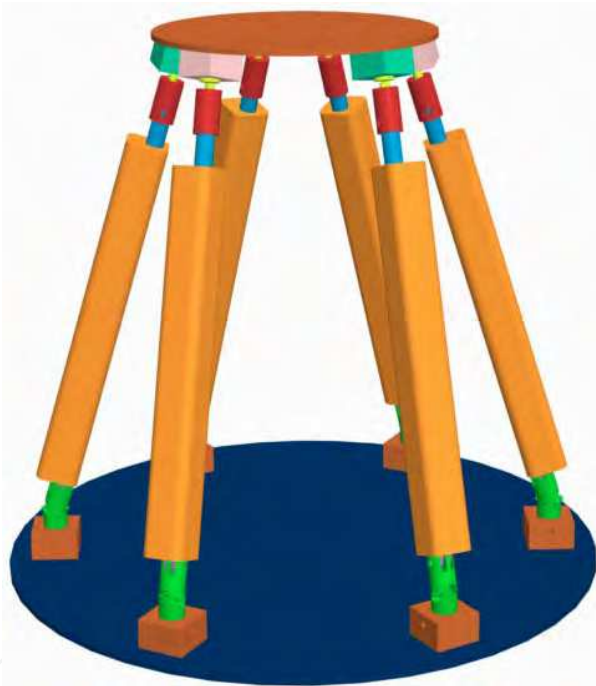

Figure 4. CAD model of parallel mechanism

#### 2.4 Robot Design: Control

The requirement for control of position and force for the robot is currently not well understood. Efforts have been made to determine the maximum forces involved by Maeda et al. (2005) and Gössling et al. (2006). They have both used different methods to measure forces experimentally and have provided useful data however, results suffer from a number of shortcomings. External events influence the force measured either from muscle activation, friction, or additional measured force components from the techniques used. Modeling and simulation offers an alternative to the limitations of *in vivo* results and has been used widely in other applications such as determining the passive force the jaw (Curtis et al., 1999; Peck et al., 2002).

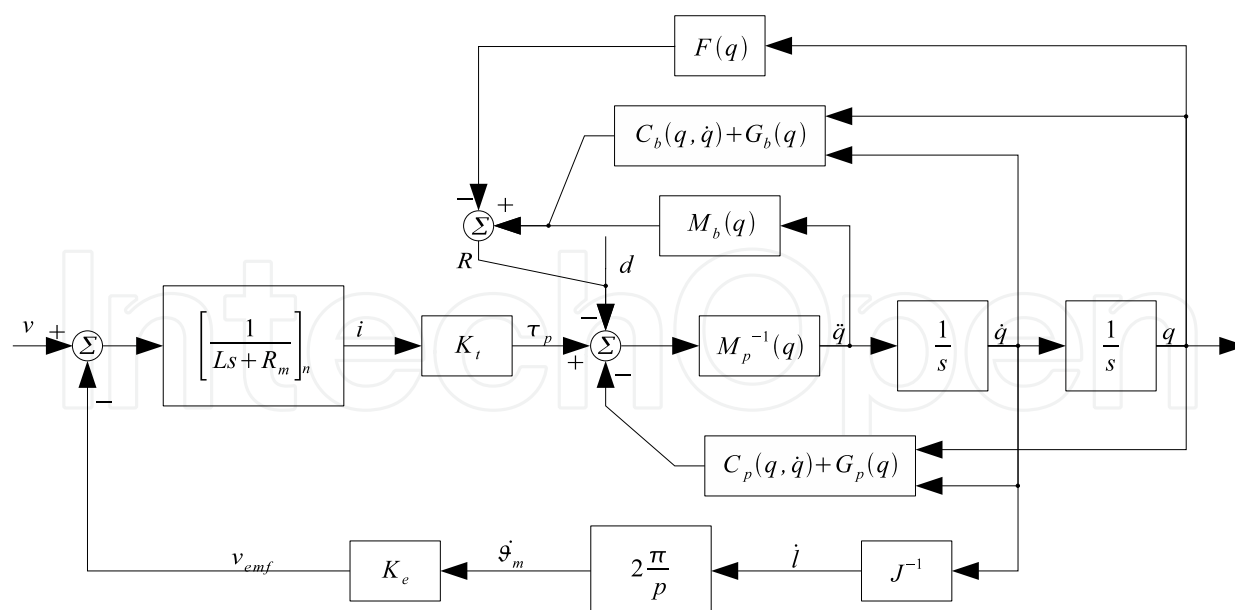

Figure 5. System diagram of the parallel robot and fractured bone

To construct a model for developing control strategies the simulated fracture force Eqn. 4. in section 2.2 is combined with a simulated parallel platform. Modeling of a parallel platform is well understood and examples of kinematics and dynamics can be found in work by Harib & Srinivasan (2003) or Guo & Li (2006). The model used in this research incorporates dynamics of the platform, link dynamics and actuator electrical and mechanical dynamics. The resulting equation is also presented in the form

$$M_p(q)\ddot{q} + C_p(q, \dot{q})\dot{q} + G_p(q) = \tau_p - d \tag{5}$$

where

$$\tau_p = K_t i \tag{6}$$

$$L \frac{di}{dt} + R_m i + K_e \dot{\theta}_m = v \tag{7}$$

and  $\tau_p$  are the actuating forces for each link,  $d$  an external disturbance,  $K_t$  motor torque constant,  $i$  the current,  $L$  motor armature inductance,  $R_m$  motor armature resistance,  $K_e$  back emf,  $\dot{\theta}_m$  motor angular velocity, and  $v$  the voltage applied.

The complete system is shown in Fig. 5. where the external reaction force from the fractured bone is treated as a disturbance.

The parallel robot should achieve reduction with a low force as well as position accuracy to prevent damage to soft tissue while achieving best possible union. Considering the main control tasks involve pulling and twisting the leg to comply with the environment there is an intrinsic requirement for controlling force as well as position. To enable this a force sensor is attached between the plate of the parallel robot and the end-effector interacting with the patient measuring the three orthogonal axes. This will also serve as a safety device

if forces become larger than a threshold value. This will be achieved by providing the correct level of perception and cognition as part of the collaborative control.

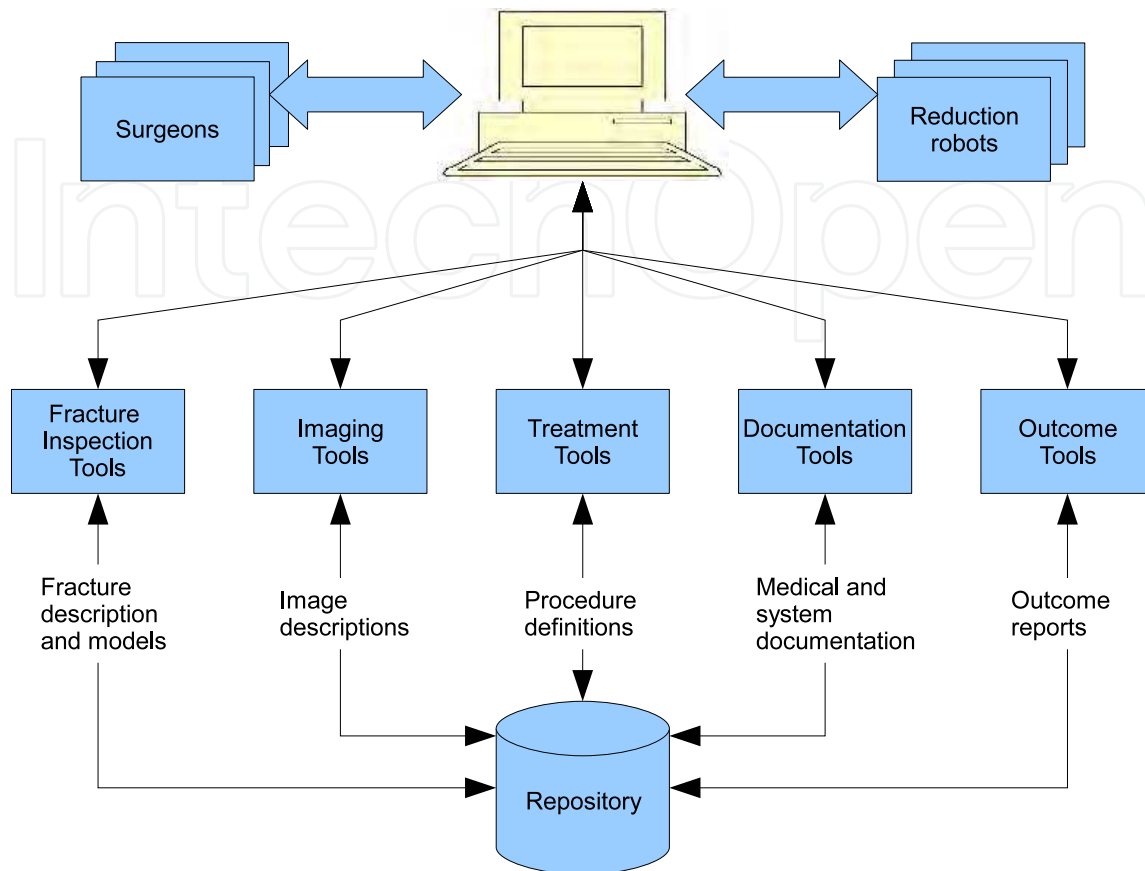

Figure 6. Database for a medical robotic system used to reduce fractured bones

### 2.3 Database Support

A database is used to track surgery performance. Typically true success of operations may not be known for a period of time measured by years, so improvements and new techniques are slow to propagate through. With operations performed in the digital domain many aspects of the surgery can be stored and tracked, potentially leading to the development of metrics that can be assessed. This may allow evaluation of good or bad outcomes or even indicate the appropriate corrective action much quicker. The database should also act as a supporting technology for pre-operative planning and inter-operative surgery and help bring greater expertise to the surgeon and patient through wide distribution of knowledge and experience. Data stored here would include the generic models of bones, muscle data, and tools that can be used during the surgical process.

Fig. 6. shows how such a system could work with multiple surgeons performing multiple operations with the fracture reduction robot. These are interfaced through a computer to a single global repository where the data is stored. Fracture descriptions, models, image descriptions, procedure definitions, medical and system documentation and outcome reports can be stored within the repository and updated each time the surgeon and robot takes the appropriate action. Storing the data will help build the tools used for all future fracture inspections, lead to enhancement in imaging and accurate treatment with a high

rate of successful outcomes. Documentation tools on the same system provide quick and uniform access to searchable information saving time through reading distributed text books. Overtime this could potentially build to be a very useful resource and help to identify the metrics to better assess the surgical procedure.

### 3. Results

In this section the results that have been achieved to date are presented. These are from modeling and visualization of the geometric bones to display to the surgeon and investigate the fracture as well as the expected force generated. The prototype robotic platform is presented along with the setup to mimic the fracture reduction environment. Lastly the initial results from processing fluoroscopy x-ray images are given.

#### 3.1 Modeling and Visualization

The modeled bones (Fig. 7.) are used to view the lower extremity, allowing rotation, and zooming. The user can select which bones to view from the sacrum, hip, femur, tibia, fibula, patella as well as which muscles to show if desired. Similarly a fracture can be created and explored. The user also has the option of displaying which muscles will have an influence on the force required to achieve reduction (Fig. 8.). These are displayed as lines from the muscle insertion locations. The location of muscles, parameters that define their force generation and the size of the bones may be changed as the user desires.

The force during a reduction may be found from any pose of the distal fragment by Eqn. 4. and calculated during the movement of the fragment. For example the reduction force under constant velocity has a maximum force of -352 N (Fig. 9.) from an initial displacement of 20,-40,40 mm in  $x$ ,  $y$  and  $z$  respectively with no malrotation.

#### 3.2 Prototype Device

The prototype device (Fig. 10.) consists of a 6 DoF parallel platform mechanism and reduction table. The platform is mounted horizontally and attaches to the manual DoF part of the reduction table. In this example a foot holster is used to attach the platform to the recipients leg and perform reduction. Alternatively the robot may be attached directly to the femur with a pin through the femur head. The user can currently control the trajectory of the parallel platform from a work station located away from the fractured bone. The specified trajectory consists of a number of discrete points which are processed by a 6 axis control card and amplified to the move the platforms 6 individual ball screw actuators. Optical encoders on each actuator provide position feedback for closed loop control of the trajectory.

#### 3.3 3-D Bone Reconstruction

To determine the pose of the distal fragment consecutive images are joined together by the user to create a panorama of images showing the bone in lateral and anteroposterior (AP) views. The translation is then found by the user selecting 22 common points (Fig. 11.). These points are typically located around the perimeter of the bone similar to where the surgeon would usually inspect during surgery. Points are selected by a point and click method and accuracy depends on the average error of selected locations. Malrotation is computed by comparing the fractured bone with a healthy bone image and a best fit match is found. This is a statistical method to give the most likely orientation.

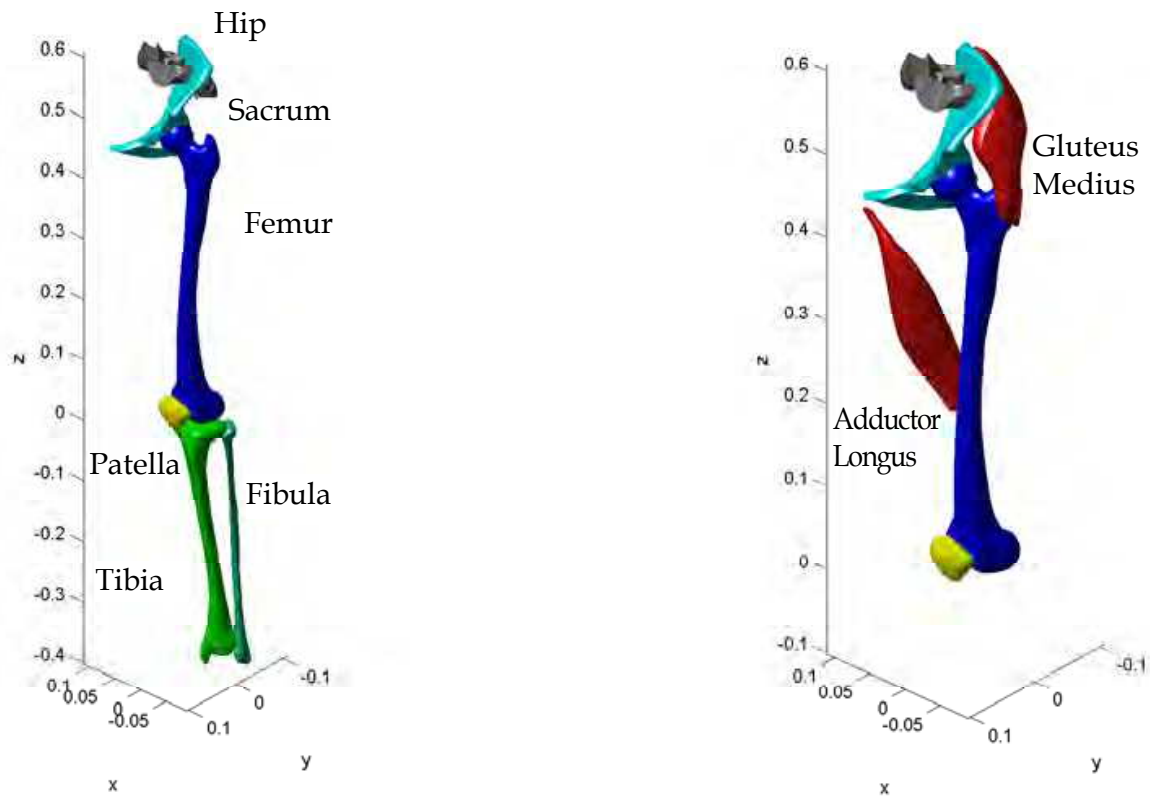

Figure 7. Investigating lower extremity, with and without visible muscle

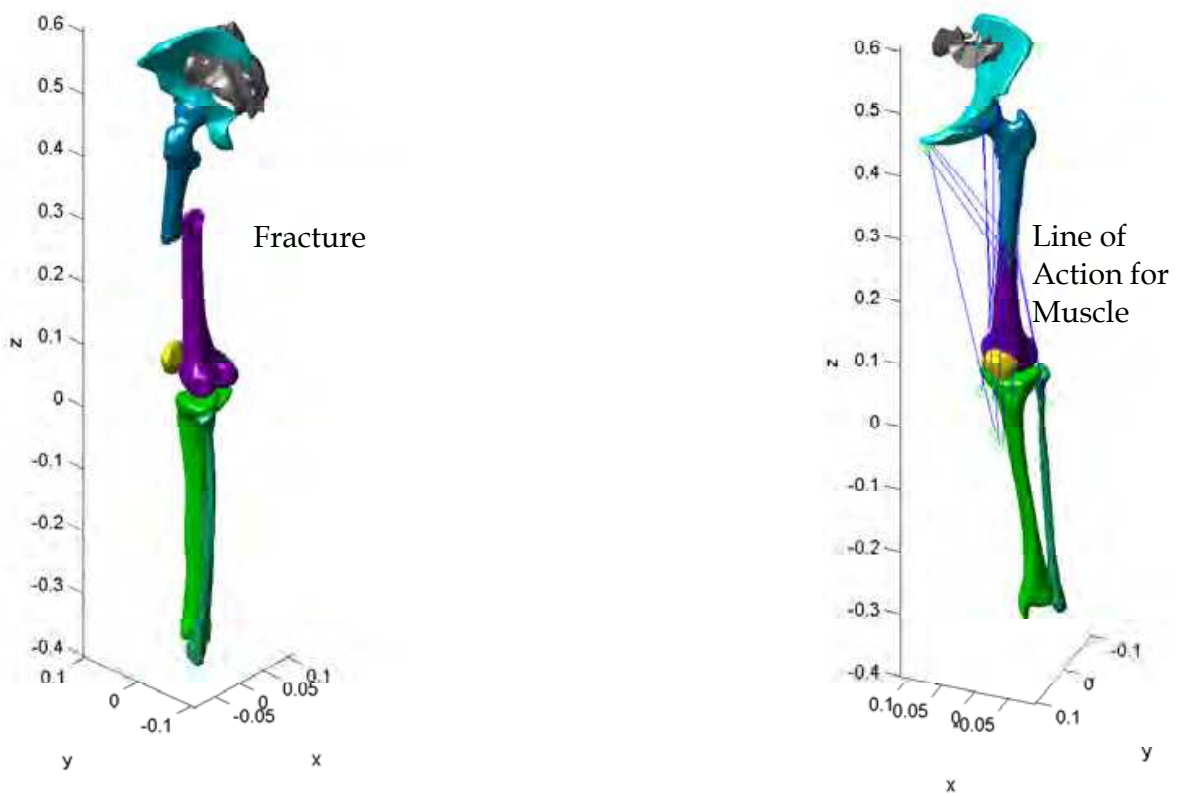

Figure 8. Investigating lower extremity when fractured and force causing muscles

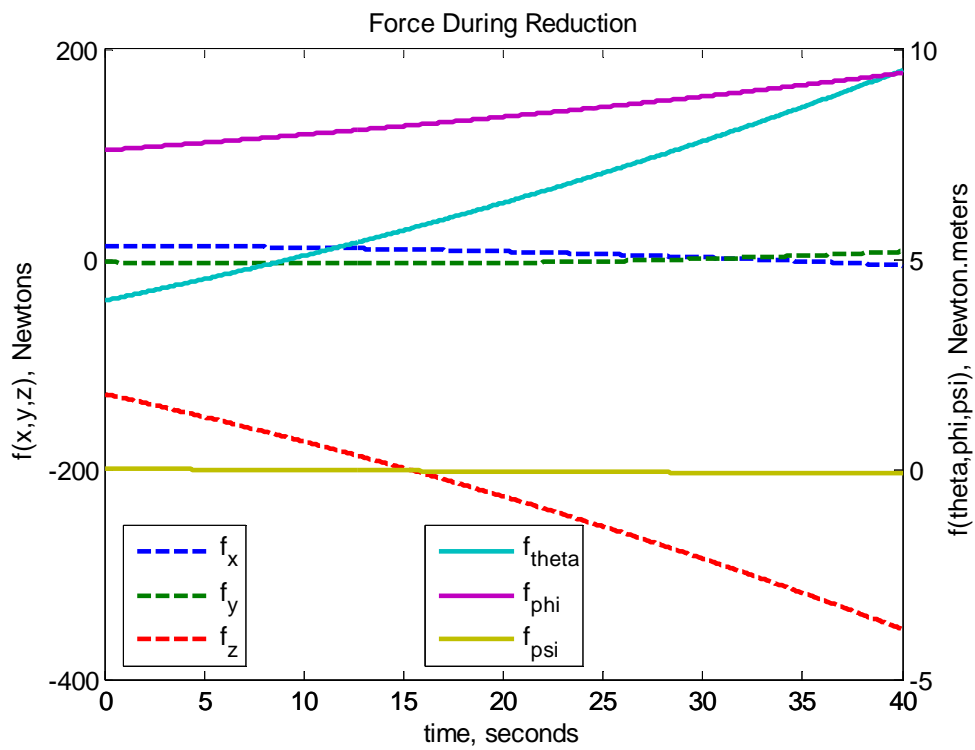

Figure 9. Simulated force during reduction

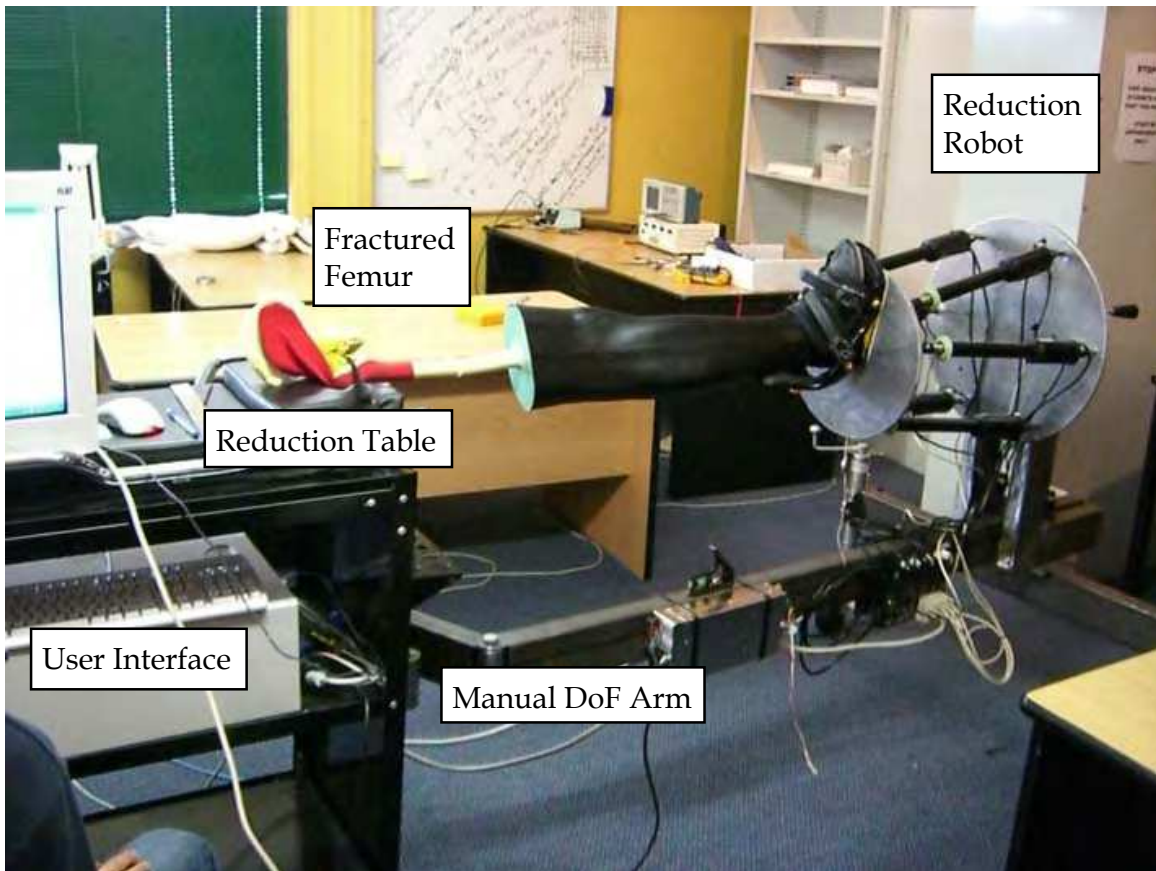

Figure 10. Prototype fracture reduction setup

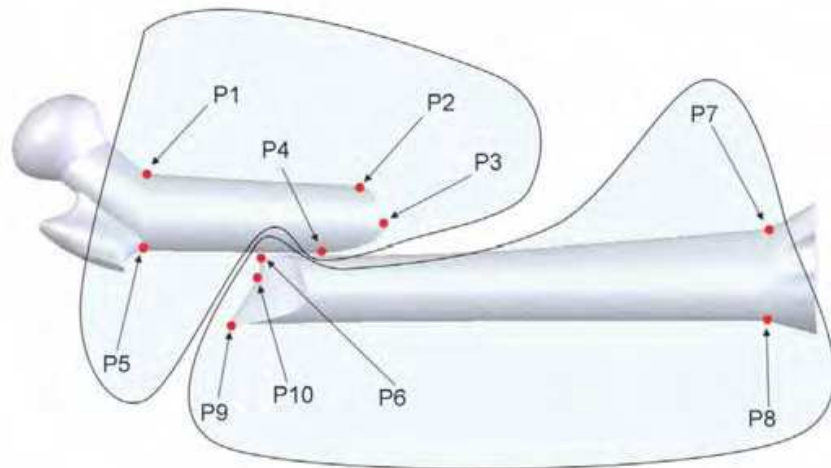

Figure 11. Selecting points in AP view

#### 4. Discussion

This research into a medical robot for realigning fractured bones aims to develop the interface, robot, and database technologies to improve the working situation for users and outcome for recipients.

Compared with other approaches to fracture reduction, the system being developed here has a number of novel features. The geometric modeling has been effective in allowing a surgeon to visualize the fractured bone and has not been reported elsewhere for fracture reduction to the authors knowledge. By displaying the images to users in this form any mental strain they would face from reconstructing images can be removed. In addition to this, modeling of the forces during reduction has provided a means to determine the requirement for a robotic device. Previously *in vivo* results had been presented (Maeda et al., 2005; Gösling et al., 2006), however these were limited and suffered from problems associated with taking measurement from living humans. The developed model provides results similar to those measured by Gösling and can be seen to validate these results. This provides a force requirement for the robot to at least exert around 400 Newton's of force.

The force model also allows the reduction to be planned and verified in 3-D while inspecting the position and expected forces involved. The combined models of bone, force and that of the parallel platform provides a mechanism to rapidly develop control strategies initially without the need for *in vivo* or phantom testing and will aid in achieving an algorithm design that provides both position accuracy and gentle reduction force. The model itself does also have limitations though. The interface between the platform and leg is assumed rigid which is not strictly true for the use of a foot holster, but if the reduction technique consisting of a pin through the femur is used this becomes more valid. Also the parameters used to develop the model are based on those of averaged cadavers taken from literature so force requirements of very athletic, young or old people need to be treated with caution. Values can be adjusted, however currently what these are is unknown. The parallel design of the robot is inherently safer than a serial mechanism and still allows the user to be distant from the fluoroscopy machine preventing the harmful radiation exposure. Although the use of parallel mechanism in the general medical robotics is not new (Jakopec et al., 2003; Brandt et al., 1999) its application to fracture reduction is. As a replacement for the existing manual traction device and using legacy imaging technology it integrates into the

current procedure. This saves the hospital resources spent on a completely new system. Matching of x-ray images to determine the pose of the fractured bone means there can be a reduction in the overall number of images. The images provide a transformation for the modeled distal fragment to the correct initial pose. This is good for the recipient reducing their radiation exposure. However the problem of processing the fluoroscopy x-ray images still needs to be properly solved.

The technologies that are still in development from the methods proposed also offer a lot of potential. In particular the control scheme to gently reduce fractures as part of a collaborative control scheme. Most medical robotics use force only as a monitored component for safety purposes. There are a few applications such as the active constraint (Ho et al., 1995) and for skin harvesting (Dombre et al., 2003) which have incorporated force into the core control however much work is left to be done here to allow safe and compliant interaction between man and machine. For the proposed scheme here it has been suggested that treating the robot as a partner is important rather than a tool. This has potential to increase acceptance which has been problematic in the field so far (Howe & Matsuoka, 1999). To achieve this the collaborative control schema will be used.

Databases are well understood, what has been described here is a method of storing the information from surgery in the digital domain over time. It is hoped that this will help spread the knowledge of what processes work and identify trends both good and bad that will ultimately lead to greater patient care.

With an increased capacity to control the reduction of the fracture and visualize the operation patients can expect fast, quality treatment. Errors in correcting malrotation can be overcome and patients can expect shorter stays in hospital while surgeons experience increases by distributing knowledge and they see an improved working environment.

This chapter has identified the problems with the existing fracture reduction method to three main stakeholders. It has then gone on to discuss a method for development of a robot for long bone fracture reduction that will address the problems each stakeholder has and presented the results obtained to date.

## 5. Future Research

Future work will be undertaken to continue to develop the driving technologies. In particular development of the control of the robotic device and the interface to surgeon. Control is currently only by position, and it is intended to expand this to include a form of force control. The robot will also be given the ability to interpret the data from its sensors and make decisions based on that data. A phantom study is planned to assess the effectiveness of the developed control strategy using artificial bones.

Much work still needs to be done into the processing of fluoroscopy images to determine if it is viable to use these for registration and obtaining the pose of the fracture segments. Even with the manual matching of images the accuracy needs to be achieved to less than 1 mm so the robot position requirements can be achieved.

## 6. References

Brandt, G.; Zimolong, A.; Carrat, L.; Merloz, P.; Staudte, H. W.; Lavalley, S.; Radermacher, K. & Rau, G. (1999). CRIGOS: a compact robot for image-guided orthopedic surgery, *IEEE Transactions on Information Technology in Biomedicine* 3(4), 252-260.



- Bruemmer, D. J.; Few, D. A.; Boring, R. L.; Marble, J. L.; Walton, M. C. & Nielsen, C. W. (2005). Shared Understanding for Collaborative Control, *IEEE Transactions on Systems, Man, and Cybernetics-Part A: Systems and Humans*, Vol. 35, No. 4, 494-504.
- Canale, S. T. & Campbell, W. C. (2003). *Campbells operative orthopaedics*, Vol. 3, Mosby, St. Louis.
- Cinquin, P.; Bainville, E.; Barbe, C.; Bittar, E.; Bouchard, V.; I. Bricault; Champleboux, G.; Chenin, M.; Chevalier, L.; Delnondedieu, Y.; Desbat, L.; Dessenne, V.; Hamadeh, A.; Henry, D.; Laieb, N.; lavallee, S.; Lefebvre, J.M.; Leitner, F.; Menguy, Y.; Padiou, F.; Peria, O.; Poyet, A.; Promayon, M.; Rouault, S.; Sautot, P.; Troccaz, J. & Vassal, P. (1995). Computer Assisted Medical Interventions: Passive and semi-active aids, *IEEE Engineering in Medicine and Biology Magazine*, Vol. 14, No. 3, 254-263.
- Curtis, D. A.; Plesh, O.; Hannam, A. G.; Sharma, A. & Curtis, T. A. (1999). Modeling of jaw biomechanics in the reconstructed mandibulectomy patient. *Journal of Prosthetic Dentistry*, Vol. 81, No. 2, 167-173.
- Cleary, K.; Clifford, M.; Stoianovici, D.; Freedman, M.; Mun, S. K. & VanceWatson (2002). Technology Improvements for Image-Guided and Minimally Invasive Spine Procedures, *IEEE Transaction on Information Technology in Biomedicine*, Vol. 6, No. 4, 249-261.
- Cleary, K.; Ibanez, L.; Navab, N.; Stoianovici, D.; Patriciu, A. & Corral, G. (2003). Segmentation of surgical needles for fluoroscopy servoing using the insight software toolkit (ITK), *Proceedings of the 25th Annual International Conference of the IEEE EMBS*, pp. 698-701.
- Davies, B.; Starkie, S.; Harris, S. J.; Agterhuis, E.; Paul, V. & Auer, L. M. (2000). Neurobot: a special-purpose robot for neurosurgery, *International Conference on Robotics and Automation*, Vol. 4, 4103-4108.
- Dombre, E.; Duchemin, G.; Poignet, P. & Pierrot, F. (2003). Dermalob: A safe robot for reconstructive surgery, *IEEE Transactions on Robotics and Automation*. Vol. 19, No. 5, 876-884.
- Fong, T.; Grange, S.; Thorpe, C. & Baur, C. (2001). Multi-robot remote driving with collaborative control, *Proceedings 10th IEEE International Workshop on Robot-Human Interactive Collaboration*, pp. 237-242.
- Fong, T.; Thorpe, C. & Baur, C. (2003). Robot, asker of questions. *Robotics and Autonomous Systems*, Vol. 42, 235-243.
- Fong, T.; Scholtz, J.; Shah, J. A.; Fluckiger, L.; Kunz, C.; Lees, D.; Schreiner, J.; Siegel, M.; Hiatt, L. M.; Nourbakhsh, I.; Simmons, R.; Ambrose, R.; Burrige, R.; Antonishek, B.; Bugajska, M.; Schultz, A. & Trafton, J. G. (2006). A preliminary study of peer-to-peer human-robot interaction, *Proceedings of the IEEE Conference on Systems, Man, and Cybernetics*.
- Friederich, J. A. & Brand, R. A. (1989). Muscle fiber architecture in the human lower limb. *Department of Orthopaedic Surgery Biomechanics Laboratory Technical report*, The University of Iowa, Iowa.
- Goodrich, M. A.; McLain, T. W.; Anderson, J. D.; Sun, J. & Crandall, J. W. (2007). Managing autonomy in robot teams: observations from four experiments, *Proceeding of the ACM/IEEE international conference on Human-robot interaction*, pp. 25-32.
- Gösling, T.; Westphal, R.; Hüfner, T.; Faulstich, J.; Kfuri Jr., M.; Wahl, M. & Krettek, C. (2005). Robot-assisted fracture reduction: A preliminary study in the femur shaft. *Medical and Biological Engineering and Computing*, Vol. 43 No. 1, 115-120.

- Gösling, T.; Westphal, R.; Fäulstich, J.; Sommer, K.; Wahl, F.; Krettek, C. & Hufner, T. (2006). Forces and Torques during Fracture Reduction: Intraoperative Measurements in the Femur. *Journal of Orthopaedic Research*, Vol. 24 No. 3, 333-338.
- Graham, A. E.; Xie, S. Q.; Aw., K. C.; Xu, W. L. & Mukherjee, S. (2006). Design of a Parallel Long Bone Fracture Reduction Robot with Planning Treatment Tool, *Proceedings of the 2006 IEEE/RSJ International Conference on Intelligent Robots and Systems*, pp. 1255-1260.
- Guo, H. B. & Li, H. R. (2006), Dynamic analysis and simulation of a six degree of freedom Stewart platform manipulator, *Proceedings of the Institution of Mechanical Engineers*, 61 - 72.
- Harib, K. & Srinivasan, K. (2003), Kinematic and dynamic analysis of Stewart platform-based machine tool structures. *Robotica*, Vol. 21, 541-554.
- Ho, S. C.; Hibberd, R. D. & Davies, B. L. (1995). Robot assisted knee surgery. *IEEE Engineering in Medicine and Biology Magazine*, Vol. 14, No. 3, 292-300.
- Howe, R. D. & Matsuoka, Y. (1999). Robotics for surgery. *Annual Review of Biomedical Engineering*, Vol. 1, 211-40.
- Jakopec, M.; Rodriguez y Baena, F.; Harris, S. J.; Gomes, P.; Cobb, J. & Davies, B. L. (2003). The hands-on orthopaedic robot "acrobot": Early clinical trials of total knee replacement surgery. *IEEE Transactions on Robotics and Automation*, Vol. 19, No. 5, 902-911.
- Joskowicz, L.; Milgrom, C.; Simkin, A.; Tockus, L. & Yaniv, Z. (1998). FRACAS: a system for computer-aided image-guided long bone fracture surgery. *Computer Aided Surgery*, Vol. 3, No.6, 271-288.
- Kazanzides, P.; Zuhars, J.; Mittelstadt, B.; Williamson, B.; Cain, P.; Smith, F.; Rose, L. & Musits, B. (1992). Architecture of a surgical robot, *IEEE International Conference on Systems, Man, and Cybernetics*, Vol. 2, 1624-1629.
- Krotkov, E.; Simmons, R.; Cozman, F. & Koenig, S. (1996). Safeguarded Teleoperation for Lunar Rovers: From Human Factors to Field Trials, *Proceedings of the IEEE Workshop on Planetary Rover Technology and Systems*.
- Libin, A. V. & Libin, E. V. (2004). Person-robot interactions from the robopsychologists' point of view: the robotic psychology and robototherapy approach, *Proceedings of the IEEE*, Vol. 92, No. 11, 1789-1803.
- Loser, M. H. & Navab, N. (2000). A new robotic system for visually controlled percutaneous interventions under CT fluoroscopy, In: *Medical Image Computing and Computer-Assisted Intervention – MICCAI 2000*, Springer Berlin, Heidelberg, pp. 887-896.
- Maeda, Y.; Tamura, Y.; Saito, M.; Yamamoto, T.; Yonenobu, K.; Warisawa, S.; Mitsuishi, M. & Sugano, N. (2005). Measurement of traction load and torque transferred to the lower extremity during simulated fracture reduction. *International Congress Series* 1281, 674-679.
- Masamune, K.; Fichtinger, G.; Patriciu, A.; Susil, R. C.; Taylor, H. R.; Kavoussi, L. R.; Andreson, J. H.; Sakuma, I.; Dohi, T. & Stoianovici, D. (2001). System for Robotically Assisted Percutaneous Procedures with Computer Tomography Guidance. *Computer Aided Surgery*, Vol. 6, 370-383.
- Paul, H. A.; Bargar, W. L.; Mittelstadt, B.; Kazanzides, P.; Musits, B.; Zuhars, J.; Cain, P. W.; Williamson, B. & Smith, F. G. (1992). Robotic execution of a surgical plan, *IEEE International Conference on Systems, Man and Cybernetics*, Vol. 2, 1621-1623.

- Peck, C. C., Sooch, A. S. & Hannam A. G. (2002). Forces resisting jaw displacement in relaxed humans: a predominantly viscous phenomenon. *Journal of Oral Rehabilitation*, Vol. 29, No. 2, 151-160.
- Rendsburg, M.; Xu, W. & Mukherjee, S. (2005). Surgeon-instructed, Image-guided and Robot-assisted Long Bone Fractures Reduction, *1st International Conference on Sensing Technology*, pp. 78-84.
- Shen, J.; Ibanze-Guzman, J.; Ng, T. C. & Chew, B. S. (2004). A Collaborative-Shared Control System With Safe Obstacle Avoidance Capability, *Proceeding of the 2004 IEEE Conference on Robotics, Automation and Mechatronics*, pp. 119-123.
- Skjeldal, S. & Backe, S. (1987). Interlocking medullary nails - Radiation doses in distal targeting. *Archives of Orthopaedic Trauma Surgery*, Vol. 106, 179-181.
- Sourina, O.; Sourin, A. & Sen, H. T. (2007). Orthopedic Surgery Training Simulation. *Journal of Mechanics in Medicine and Biology*, Vol. 7, No. 1, 37-53.
- Stoianovici, D.; Cleary, K.; Patriciu, A.; Mazilu, D.; Stanimir, A.; Craciunoiu, N.; Watson, V. & Kavoussi, L. (2003). AcuBot: a robot for radiological interventions. *IEEE Transactions on Robotics and Automation*, Vol. 19, No. 5, 927-930.
- Taylor, R. H.; Mittelstadt, B. D.; Paul, H. A.; Hanson, W.; Kazanzides, P.; Zuhars, J. F.; Williamson, B.; Musits, B. L.; Glassman, E. & Bargar, W. L. (1994). An image-directed robotic system for precise orthopaedic surgery. *IEEE Transactions on Robotics and Automation*, Vol. 10, No. 3, 261-275.
- Wang, T.; Liu, W. & Hu, L. (1992). BPOR: a fluoroscopy-based robot navigating system for distal locking of intramedullary nails, *Proceedings of 2004 IEEE/RSJ International Conference on Intelligent Robots and Systems*, pp. 3321-3326.
- Warisawa, S.; Ishizuka, T.; Mitsuishi, M.; Sugano, N.; Yonenobu, K. & Nakazawa, T. (2004). Development of a femur fracture reduction robot, *Proceedings of the 2004 IEEE International Conference on Robotics & Automation*, pp. 3999-4004.
- Westphal, R.; Gössling, T.; Oszwald, M.; Bredow, J.; Klepzig, D.; Winkelbach, S.; Hüfner, T.; Krettek, C. & Wahl, F. (2006). 3D Robot Assisted Fracture Reduction. *Proceedings of 10th International Symposium on Experimental Robotics*.
- Winters, J. & Stark, L. (1985). Analysis of fundamental movement patterns through the use of indepth antagonistic muscle models. *IEEE Transactions on Biomedical Engineering.*, Vol. 32, 826-839.
- Winters, J. M. & Stack, L. (1988). Estimated mechanical properties of synergistic muscle involved in movements of a variety of human joints. *Journal of Biomechanics*, Vol. 21, 1027-1041.



## **Medical Robotics**

Edited by Vanja Bozovic

ISBN 978-3-902613-18-9

Hard cover, 526 pages

**Publisher** I-Tech Education and Publishing

**Published online** 01, January, 2008

**Published in print edition** January, 2008

The first generation of surgical robots are already being installed in a number of operating rooms around the world. Robotics is being introduced to medicine because it allows for unprecedented control and precision of surgical instruments in minimally invasive procedures. So far, robots have been used to position an endoscope, perform gallbladder surgery and correct gastroesophageal reflux and heartburn. The ultimate goal of the robotic surgery field is to design a robot that can be used to perform closed-chest, beating-heart surgery. The use of robotics in surgery will expand over the next decades without any doubt. Minimally Invasive Surgery (MIS) is a revolutionary approach in surgery. In MIS, the operation is performed with instruments and viewing equipment inserted into the body through small incisions created by the surgeon, in contrast to open surgery with large incisions. This minimizes surgical trauma and damage to healthy tissue, resulting in shorter patient recovery time. The aim of this book is to provide an overview of the state-of-art, to present new ideas, original results and practical experiences in this expanding area. Nevertheless, many chapters in the book concern advanced research on this growing area. The book provides critical analysis of clinical trials, assessment of the benefits and risks of the application of these technologies. This book is certainly a small sample of the research activity on Medical Robotics going on around the globe as you read it, but it surely covers a good deal of what has been done in the field recently, and as such it works as a valuable source for researchers interested in the involved subjects, whether they are currently “medical roboticists” or not.

### **How to reference**

In order to correctly reference this scholarly work, feel free to copy and paste the following:

A. E. Graham, S. Q. Xie, K. C. Aw, W. L. Xu and S. Mukherjee (2008). Robotic Long Bone Fracture Reduction, Medical Robotics, Vanja Bozovic (Ed.), ISBN: 978-3-902613-18-9, InTech, Available from: [http://www.intechopen.com/books/medical\\_robotics/robotic\\_long\\_bone\\_fracture\\_reduction](http://www.intechopen.com/books/medical_robotics/robotic_long_bone_fracture_reduction)

**INTECH**  
open science | open minds

### **InTech Europe**

University Campus STeP Ri  
Slavka Krautzeka 83/A  
51000 Rijeka, Croatia  
Phone: +385 (51) 770 447

### **InTech China**

Unit 405, Office Block, Hotel Equatorial Shanghai  
No.65, Yan An Road (West), Shanghai, 200040, China  
中国上海市延安西路65号上海国际贵都大饭店办公楼405单元  
Phone: +86-21-62489820

Fax: +385 (51) 686 166  
www.intechopen.com

Fax: +86-21-62489821

IntechOpen

IntechOpen

© 2008 The Author(s). Licensee IntechOpen. This chapter is distributed under the terms of the [Creative Commons Attribution-NonCommercial-ShareAlike-3.0 License](https://creativecommons.org/licenses/by-nc-sa/3.0/), which permits use, distribution and reproduction for non-commercial purposes, provided the original is properly cited and derivative works building on this content are distributed under the same license.

IntechOpen

IntechOpen