



Modelling and Control of Standing Up and Sitting Down Manoeuvre

A. J. Ishak^{1*}, M. O. Tokhi², M. S. Al-Quraishi¹, D. M. Linares² and S. K. Ali²

¹Department of Electrical and Electronic Engineering, Faculty of Engineering, Universiti Putra Malaysia, 43400 UPM, Serdang, Selangor, Malaysia

²Department of Automatic Control and Systems Engineering, The University of Sheffield, United Kingdom

ABSTRACT

Exoskeleton Robot is one of the most significant examples of human-oriented robotic devices. Nevertheless, the main challenge remains the complexity of their mechanical design and human-robot interfaces. This paper is an outcome of a research to model and to simulate the support of mobility of an elderly people using exoskeleton. Exoskeleton is developed in order to complement the corporal deficiencies of an elderly person in standing up and sitting down. When the natural joint torques is integrated with the exoskeleton's torque the result is in an overall torque that is comparable to that of a physically normal person. This work focuses on standing-up and sitting-down movements. Appropriate simulation models are formulated and their performances examined against measured data. The results with PID control show that at different speed of standing up and sitting down, the joint torques can be compromised. This is done within allowable limits.

Keywords: Exoskeleton, humanoid model, PID control, Joint Torque International Conference on Electrical & Electronic Technology 2016

ARTICLE INFO

Article history:

Received: 24 August 2016

Accepted: 03 Jun 2017

E-mail addresses:

asnorji@upm.edu.my (A. J. Ishak),

o.tokhi@sheffield.ac.uk (M. O. Tokhi),

mdg_eng@hotmail.com (M. S. Al-Quraishi),

d.miranda-linares@sheffield.ac.uk (D. M. Linares),

skalil@sheffield.ac.uk (S. K. Ali)

*Corresponding Author

INTRODUCTION

The aptitude to perform daily activities can be affected by accident or chronic diseases. This may result in the loss of human abilities. There is a dire need for rehabilitation programme and physical therapy for human recovery especially for post patients recovering from stroke. Research has focused on developing exoskeleton robots, which are used to rehabilitate the patient, in particular to support the upper or the lower limbs, for example, ankles, knees and hip joints.

Exoskeleton robots play an important role in biomedical, industrial, and aerospace applications. For instance, in biomedical applications, they are used to support patients recovering from stroke. Stroke victims often require assistance and regular physiotherapy during their recovery period. The elderly and the disabled face difficulties with mobility and researches and scientists have developed different types of exoskeletons robots to enhance their mobility, and for rehabilitation purposes. What is the Exoskeleton Robot? It is an external mechanical structure having joints similar to the body of a human. This wearable robot is able to transmit torques from the actuators to the joints of the human body through the rigid links of the exoskeleton (Kiguchi et al., 2012). The exoskeleton can be controlled using different techniques according to the interaction between the human body and the devices. Those techniques can be classified according to the human-robot interaction method: the signals measured from the exoskeleton, the interaction force signal measured between the human and the exoskeleton, and the biosignal measured from the human body.

Several studies have been conducted in the field of exoskeleton robots. The devices can be categorised according to the mechanical architecture, control approach, degree of freedom and the assistance provided. Lower limb exoskeleton with three degrees of freedom for each leg by Exso Bionics is one of the most innovative assistive robots (Strickland, 2012). Three joints are implemented whereby two are active joints, namely hip and knee, and one is passive, namely ankle joint. The active joints are actuated by brushless DC motors. More than 15 sensors (force sensors and encoders) are employed for control and balancing purposes. The EXPOS is a lightweight exoskeleton system which is attached to an intelligent cast walker and provides mobility to senior citizens (Kong et al., 2006). The Center for Intelligent Mechatronics of the Vanderbilt University successfully developed Vanderbilt Exoskeleton which has two degrees of freedom (Quintero et al., 2011). The actuation of the movements of the hip and knee are done by positioning two brushless DC motors at the thigh position. One of the advantages of this exoskeleton is the lightweight design that reflects a slender profile. Further, there is no need for footplate or large backpack components. Nevertheless, the equilibrium of the subject is managed using a set of crutches. One of the most popular exoskeletons is Cyberdyne's robot Fit HAL (Hybrid Assistive Limb) (Aach et al., 2013). It is an exoskeleton completely equipped with a lower limb. It supports the person in terms of movement such as standing up and sitting down by detecting the Electromyography signal to comply with the movements of the user (Cyberdyne, 2015). Compared with the exoskeletons mentioned above, HAL provides both a lower and upper limb exoskeleton, in order to supply and to enhance the human physical ability in different fields such as rehabilitation, physical training, large labour and safe support.

Taking into account the challenges of mechanical design and the control approaches, this paper describes the modelling and simulation phase of the sit-to-stand and stand-to-sit tasks, and analyses the system torque and force requirements under various situations.

MATERIALS AND METHODS

The mathematical model of the complete lower limb musculoskeletal system is complex. Therefore, the MSC Visual Nastran 4D (VN4D) software is used to model and to simulate the movements of standing up and sitting down. The VN4D setting makes it possible for the creation of a humanoid model which responds in a genuine way to external forces, namely

gravity and weight. There are three main goals to be achieved by utilising VN4D in this work. The first goal is to construct the humanoid model segments designed by Solid Work and to integrate them with suitable dynamic properties. Second, to measure the mechanical parameters such as torque, orientation and centroids of the links which interface with Matlab Simulink model later for further analysis and to utilise them as a control input to drive the exoskeleton. Finally, it attempts to capture the interaction of the exoskeleton with external energies and disorders in a realistic way and at the same time display the humanoid motions [6].

Humanoid Model Design

Solid Works generated different segments of a human-like model based on specifications by Winter (2009). Its weight is 80kg and its height is 1.8m. When the design is completed, each segment can be exported and constructed in VN4D. The position of the joints is anatomically taken into consideration. Generally, the human body has 32 main degrees of freedom (DoF). In the proposed human form as shown by the model in Figure 1, only 13 DoF were involved in both frontal and lateral planes. The transversal plane on the other hand, is blocked.



Figure 1. (a) Lateral Plane (b) FrontalPlane (Strickland, 2012)

Standing Up and Sitting Down Motion

Karlj and Bajd (1989) divided the standing-up manoeuvre into four segments: initiation, seat uploading, ascending and stabilisation, lasting around 1.5s. The required torque profiles for standing up and sitting down movement are given in Figure 2.

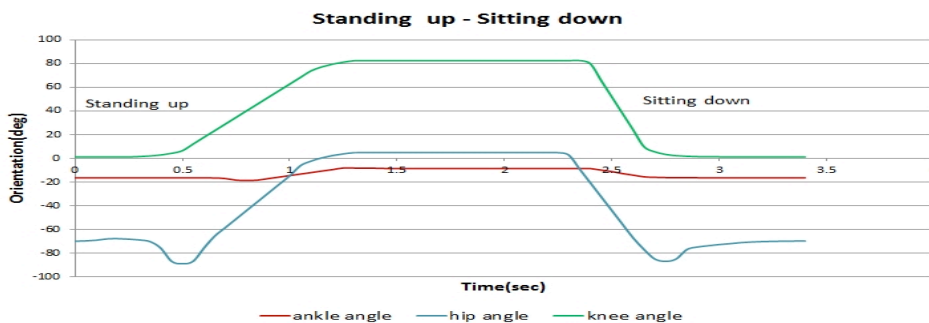

Figure 2. Joint's orientation during standing up and sitting down manoeuvres (Kralj et al., 1989)

EXPERIMENTS AND RESULTS

A closed loop PID control was implemented for set-point tracking of each joint. In order for the value to stay below the normal limits, a saturation block was included at the PID controller output as depicted in Figure 3.

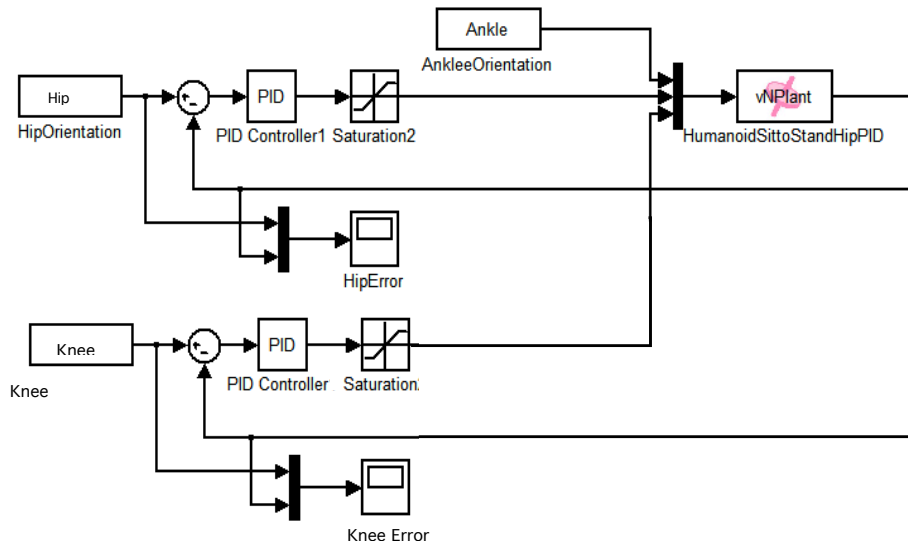

Figure 3. PID control in Simulink for ankle, hip and knee joints

P, I and D gains for each joint were obtained separately. Ankle and knee trajectories were directly connected to motors actuated by orientation at the plant. The Mean squared error (MSE) between hip orientation reference and actual value was calculated and a comparison of the resulting MSE was performed and the gains which generated the lowest error were recorded. The same process was repeated to get P, I and D gains for knee, having the reference trajectories of ankle and hip directly sent to the plant. Table 1 and Table 2 illustrate the best results of the initial and lower torque level trials by setting the saturation level 160 Nm and 210Nm for the hip and knee joints respectively.

Table 1
PID gains for initial trial

PID gains	Hip	Knee
Proportional	16	16
Derivative	2	8
Integral	1.6	3.2
MSE	9.19	7.57
Saturation Limit	160 Nm	210 Nm

Table 2
PID gains for lower torques

PID gains	Hip	Knee
Proportional	14	14
Derivative	2	7.2
Integral	1.2	2.5
MSE	9.7	8.9
Saturation Limit	160 Nm	210 Nm

Thereafter, an assessment was carried out if an acceptable standing up and sitting down manoeuvre was achievable with lower torque with respect to different saturation levels. The results show that better performance was achieved with a saturation limit of 150 Nm for the hip joint and 210 Nm for the knee joint as described in Figure 4. Acceptable behaviour was achieved with lower saturation limits although the MSE was inversely proportional to the saturation value.

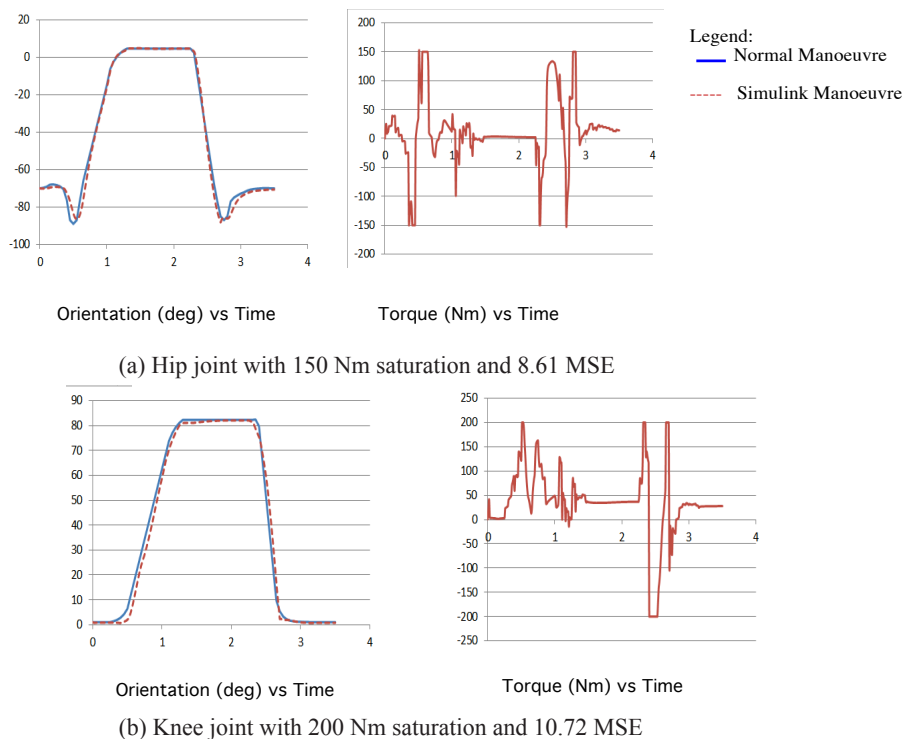

Figure 4. Hip and knee joint trajectory and torque profile

A new Simulink diagram was later created with torques from the hip and knee PID controllers as input to the plant, and ankle orientation trajectory directly sent to the plant. Following 100 trials were run and the P, I and D gains were tuned and the model was tested

with different saturation levels. Figure 5 shows sample results with saturation limits of 160 Nm for the hip joint and 210 Nm for the knee joint and 40 Nm for ankle joint. It is noted that the reference joint orientations were achieved with mean-squared errors of 7.35, 6.11 and 9.98 for the hip, knee and ankle joints respectively.

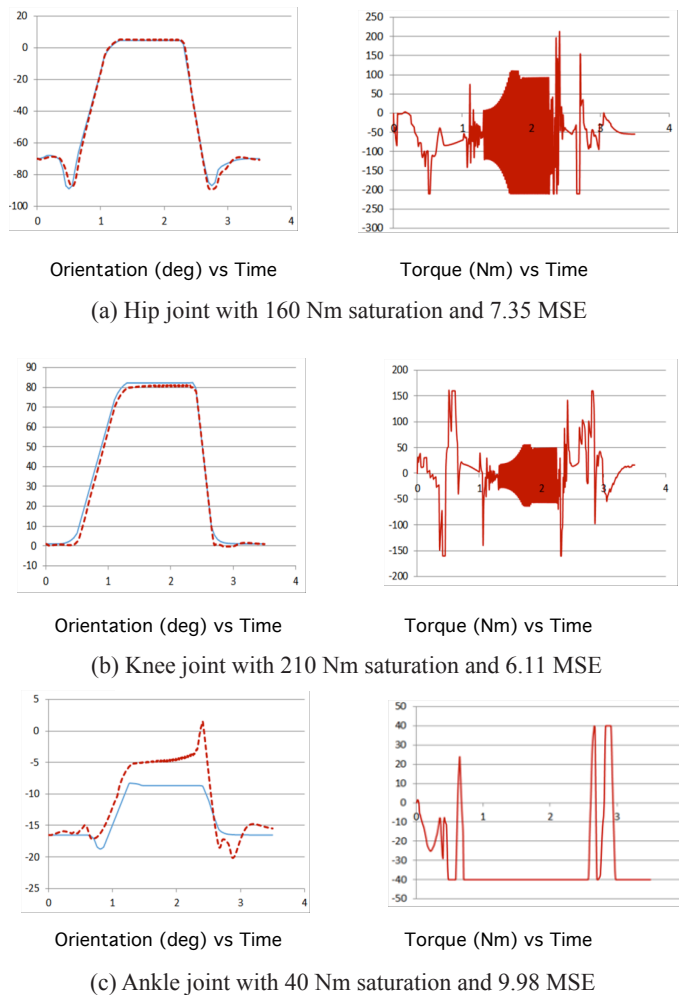

Figure 5. (a) Hip, (b) knee and (c) ankle joints trajectory and torque profiles

CONCLUSION

The modelling and simulation of the human-like model and exoskeleton model have been developed using a virtual setting for theoretical studies. This was achieved through modelling levels of movements support for senior citizens. The analysis of the required torque profiles was performed to actuate the various joint motors in order to obtain the normal joint movements. It has been shown that within appropriate control method and allowable limits, the joint torques can be developed even at different speeds of standing up and sitting down movements. Further

research is needed to understand if these investigations are adequate and within human limits with different torque saturation limits

REFERENCES

- Aach, M., Meindl, R., Hayashi, T., Lange, I., Geßmann, J., Sander, A., & Schildhauer, T. A. (2013). Exoskeletal neuro-rehabilitation in chronic paraplegic patients—initial results. In *Converging Clinical and Engineering Research on Neurorehabilitation* (pp. 233-236). Springer Berlin Heidelberg.
- Cyberdyne (2015). HAL for living support (lower limb type). (March, 2015)
- Kiguchi, K., & Hayashi, Y. (2012). An EMG-based control for an upper-limb power-assist exoskeleton robot. *IEEE Transactions on Systems, Man, and Cybernetics, Part B (Cybernetics)*, 42(4), 1064-1071.
- Kong, K., & Jeon, D. (2006). Design and control of an exoskeleton for the elderly and patients. *IEEE/ASME Transactions on Mechatronics*, 11(4), 428-432.
- Kralj, A. R., & Bajd, T. (1989). *Functional electrical stimulation: standing and walking after spinal cord injury*. CRC press.
- Miranda-Linares, D., Lopez-Coronado, J., Diaz-Hernández, C. A., Ishak, A., & Tokhi, M. (2015, August). Modelling and Simulation of Assistive Exoskeleton for Elderly Mobility. In *Assistive Robotics: Proceedings of the 18th International Conference on CLAWAR 2015* (p. 95). World Scientific.
- Quintero, H. A., Farris, R. J., & Goldfarb, M. (2011, June). Control and implementation of a powered lower limb orthosis to aid walking in paraplegic individuals. In *2011 IEEE International Conference on Rehabilitation Robotics* (pp. 1-6). IEEE.
- Strickland, E. (2012). Good-bye, wheelchair. *IEEE Spectrum*, 49(1), 30-32.
- Winter, D. A. (2009). *Biomechanics and motor control of human movement*. John Wiley & Sons.

