

IL NUOVO CIMENTO
DOI 10.1393/ncc/i2013-11535-1

VOL. 36 C, N. 4

Luglio-Agosto 2013

COMMUNICATIONS: SIF Congress 2012

Measurement of the τ lepton electric dipole moment at BaBar

S. MARTELOTTI

Department of Physics “E. Amaldi”, Università degli Studi Roma Tre

Via della Vasca Navale 84, 00146 Roma, Italy and

INFN - Laboratori Nazionali di Frascati - Via Enrico Fermi 40, 00044 Frascati (RM), Italy

ricevuto il 7 Gennaio 2013

Summary. — The search for a CP violation signature arising from an electric dipole moment of the τ lepton in the $e^+e^- \rightarrow \tau^+\tau^-$ reaction is currently in progress using 470 fb^{-1} of data collected with the BABAR detector at the PEP II collider from 1999 to 2008. In this paper the EDM search method in development will be illustrated and the required algorithms tested on Monte Carlo samples that do not take into account the detector and background effects are shown.

PACS 14.60.Fg – Taus.

PACS 31.30.jn – QED corrections to electric dipole moments and other atomic properties.

PACS 13.40.Gp – Electromagnetic form factors.

1. – Introduction

CP violation phenomena in the hadron sector can occur in the Standard Model (SM) via the presence of a single complex phase in the Cabibbo-Kobayashi-Maskawa (CKM) [1] quark mixing matrix, and has been experimentally confirmed at the B-Factories by the BABAR [2] and Belle [3] experiments in the last decade. On the contrary, the SM prediction for CP violation in the lepton sector is negligibly small and has never been observed so far. However, the presence of physics beyond the SM (BSM) could introduce these effects at experimentally accessible levels [4], making any observation of CP violation in this sector a clear evidence of new physics. In some models such effects are expected to be enhanced for the τ leptons due to its very large mass compared to other leptons, since new bosons and Higgs strongly couple with heavy particles through quantum loop effects.

As will be shown later the contribution from CP violating interactions in the τ pair production process can be parametrized at the leading order, in a model-independent way, using an electric dipole moment (EDM) of the τ lepton, d_τ .

In the case of the two, or multi-Higgs, doublet models, CP violation is generated by the interference of tree-level production process, $e^+e^- \rightarrow \gamma, H \rightarrow \tau^+\tau^-$, where H is some new Higgs boson. The strength of the interference term is proportional to the fermion masses, thus in this case the τ EDM is $\propto m_\tau$ and estimated to be $d_\tau < 4 \cdot 10^{-21}$ e cm [5]. In Higgs models containing neutral spin-0 bosons, which may couple to leptons through lepton-flavour-conserving scalar and pseudoscalar couplings, the strength of the EDM is proportional to m_l^3 [6], which results in a d_τ that can be of the order of 10^{-17} .

Searches for the τ electric dipole moment have been performed at LEP in the reaction $e^+e^- \rightarrow \tau^+\tau^-\gamma$, where the following upper limits in units of 10^{-16} e cm at 95% confidence level were obtained: $-3.1 < d_\tau < 3.1$ by L3 [7] and $-3.8 < d_\tau < 3.6$ by OPAL [8]. ARGUS [9] performed a search in the $e^+e^- \rightarrow \tau^+\tau^-$ reaction with the result of $|\text{Re}(d_\tau)| < 4.6$ and $|\text{Im}(d_\tau)| < 1.8$. The Belle collaboration studied the same reaction obtaining the best existing bound on d_τ to date [10]. Belle's EDM measurement was performed using 29.5 fb^{-1} of data collected with the Belle detector at the KEKB Collider at $\sqrt{s} = 10.58 \text{ GeV}$ and the 95% confidence level limits were set at $-2.2 < \text{Re}(d_\tau) < 4.5(10^{-17} \text{ e cm})$ and $-2.5 < \text{Im}(d_\tau) < 0.8(10^{-17} \text{ e cm})$.

The analysis discussed in this paper will be based on all the data recorded by the BABAR detector [11] at the PEP-II asymmetric-energy e^+e^- storage rings operated at the SLAC National Accelerator Laboratory. An integrated luminosity of about 470 fb^{-1} was collected. 91% of the luminosity was collected from e^+e^- annihilations at the $\Upsilon(4S)$ center-of-mass energy of $\sqrt{s} = 10.58 \text{ GeV}$, while 9% was collected 40 MeV below. With a cross section of $0.919 \pm 0.003 \text{ nb}$ [12] for τ -pair production at the BABAR center-of-mass energy, this corresponds to the production of about 432 million $\tau^+\tau^-$ events against the 26 millions analysed by Belle, which will allow us to reach a higher sensitivity on the τ EDM. The BABAR analysis is ongoing. Up to now the τ EDM measurement algorithms and methods have been studied on Monte Carlo samples. The analysis of the experimental sample is just started.

2. – EDM formalism

Deviations from the SM, at low energies, can be parametrized by an effective Lagrangian built with the standard model particle spectrum, having as zero order term just the standard model Lagrangian, and containing higher-dimension non-standard gauge invariant operators:

$$(1) \quad \mathcal{L}_{eff} = \mathcal{L}_{SM} + \Delta\mathcal{L}_{CPV}.$$

Leptonic CPV can be parametrized at leading order in a model-independent way by a dipole moment quantifying the violation. For the τ there are two operators that contribute [13] to the τ electric dipole moment d_τ and the τ weak dipole moment d_τ^W :

$$(2) \quad \Delta\mathcal{L}_{CPV}^{\tau} = -\frac{i}{2}d_\tau\bar{\psi}\sigma^{\mu\nu}\gamma_5F_{\mu\nu} - \frac{i}{2}d_\tau^W\bar{\psi}\sigma^{\mu\nu}\gamma_5Z_{\mu\nu},$$

where $F_{\mu\nu}$ is the electromagnetic field tensor, and $Z_{\mu\nu}$ is the weak field tensor. At BABAR energies we might be sensitive to the electromagnetic part. The electric dipole form factor d_τ depends in general on s , the squared energy of the τ -pair system, but in common with other analyses the possible s -dependence is ignored, assuming $d_\tau(s) \equiv d_\tau$.

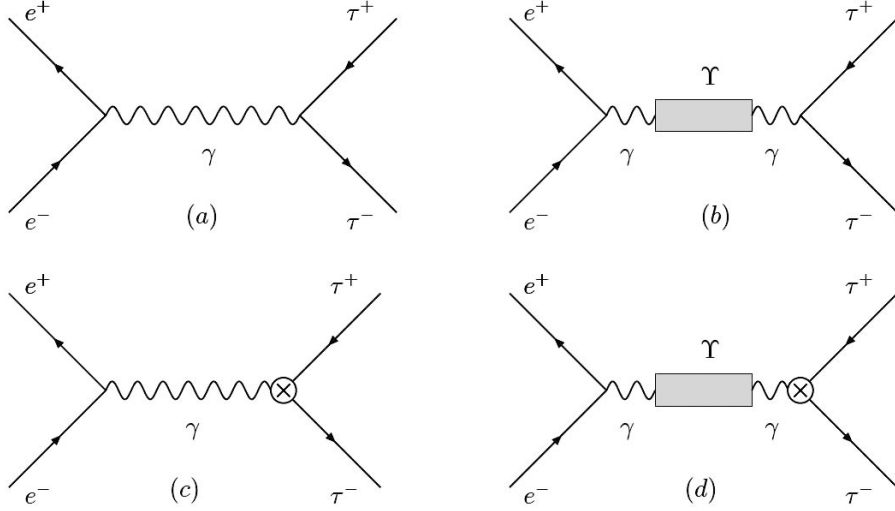

Fig. 1. – Diagrams. (a) Direct γ exchange. (b) Υ production. (c) EDM in γ exchange. (d) EDM at the Υ -peak.

The $e^+e^- \rightarrow \tau^+\tau^-$ cross section has contributions coming from the standard model and the effective Lagrangian in eq. (2). At low energies the tree level contributions come from γ exchange or Υ exchange. The interference with the Z diagrams are suppressed by powers of (q^2/M_Z^2) . The tree level contributing diagrams are shown in fig. 1: diagrams (a) and (b) are SM contributions, and (c) and (d) represent terms beyond the SM in the Lagrangian. Note that the SM radiative correction coming from quark currents that may contribute to CP -odd observables, *i.e.* the ones that generate the SM electric dipole moment for the τ , come in higher order in the coupling constant, and at the present level of experimental sensitivity they are not measurable. Then bounds on the EDM that one may get, are the bounds on the possible CPV coming from beyond the standard model physics.

Taking into account the electric dipole moment contribution in the Lagrangian, the cross section of the process:

$$e^+(\vec{p})e^-(-\vec{p}) \rightarrow \tau^+(\vec{k}, \vec{S}_+)\tau^-(-\vec{k}, \vec{S}_-)$$

where \vec{p} is the momentum vector of e^+ , \vec{k} is the momentum vector of the τ^+ and \vec{S}_\pm are the spin vectors for τ^\pm , all expressed in the center-of-mass frame, is proportional to the squared spin density matrix [14]:

$$(3) \quad \mathcal{M}_{prod}^2 = \mathcal{M}_{SM}^2 + Re(d_\tau)\mathcal{M}_{Re}^2 + Im(d_\tau)\mathcal{M}_{Im}^2 + |d_\tau|^2\mathcal{M}_{d^2}^2$$

Here, in addition to the standard term,

$$(4) \quad \mathcal{M}_{SM}^2 = \frac{e^4}{\vec{k}_0^2} [k_0^2 + m_\tau^2 + |\vec{k}^2|(\hat{k} \cdot \hat{p})^2 - \vec{S}_+ \cdot \vec{S}_- |\vec{k}^2| (1 - (\hat{k} \cdot \hat{p})^2) \\ + 2(\hat{k} \cdot \vec{S}_+)(\hat{k} \cdot \vec{S}_-)(|\vec{k}^2| + (k_0 - m_\tau)^2(\hat{k} \cdot \hat{p})^2) + 2k_0^2(\hat{p} \cdot \vec{S}_+)(\hat{p} \cdot \vec{S}_-) \\ - 2k_0(k_0 - m_\tau)(\hat{k} \cdot \hat{p})((\hat{k} \cdot \vec{S}_+)(\hat{p} \cdot \vec{S}_-) + (\hat{k} \cdot \vec{S}_-)(\hat{p} \cdot \vec{S}_+))],$$

the interference terms between the SM and the CPV amplitudes \mathcal{M}_{Re}^2 and \mathcal{M}_{Im}^2 , related to the real and imaginary part of the d_τ respectively, appear:

$$(5) \quad \mathcal{M}_{Re}^2 = 4 \frac{e^3}{k_0} |\vec{k}| [-(m_\tau + (k_0 - m_\tau)(\hat{k} \cdot \hat{p}))(\vec{S}_+ \times \vec{S}_-) \cdot \hat{k} + k_0(\hat{k} \cdot \hat{p})(\vec{S}_+ \times \vec{S}_-) \cdot \hat{p}]$$

$$(6) \quad \mathcal{M}_{Im}^2 = 4 \frac{e^3}{k_0} |\vec{k}| [-(m_\tau + (k_0 - m_\tau)(\hat{k} \cdot \hat{p}))(\vec{S}_+ - \vec{S}_-) \cdot \hat{k} + k_0(\hat{k} \cdot \hat{p})(\vec{S}_+ - \vec{S}_-) \cdot \hat{p}],$$

\mathcal{M}_{Re}^2 is CP odd and T odd, while \mathcal{M}_{Im}^2 is CP odd but T even and so it is expected to be zero if the CPT symmetry is conserved.

The higher-order term proportional to $|d_\tau^2|$:

$$(7) \quad \mathcal{M}_{d^2}^2 = 4e^2 |\vec{k}^2| (1 - (\hat{k} \cdot \hat{p})^2) (1 - \vec{S}_+ \cdot \vec{S}_-)$$

can be neglected since d_τ is small.

In these expressions k_0 is the τ energy and m_τ is the τ mass and the hat denotes a unit momentum. In the above equations, e^+ and e^- are assumed to be unpolarized and massless particles.

3. – Analysis observables

For the EDM measurement we adopt the same method of ARGUS and Belle, the so-called optimal observable method [15], which maximizes the sensitivity to d_τ . The optimal observables are defined as

$$(8) \quad \mathcal{O}_{Re} = \frac{\mathcal{M}_{Re}^2}{\mathcal{M}_{SM}^2}, \quad \mathcal{O}_{Im} = \frac{\mathcal{M}_{Im}^2}{\mathcal{M}_{SM}^2}.$$

Using the square matrix element \mathcal{M}_{prod}^2 in eq. (3), the differential cross section is expressed as $d\sigma \propto \mathcal{M}_{prod}^2 d\phi$, where ϕ denotes the phase space. The mean values of the observable \mathcal{O}_{Re} (similar expression for the imaginary part) is expressed as

$$(9) \quad \langle \mathcal{O}_{Re} \rangle \propto \int \mathcal{O}_{Re} d\sigma \propto \int \mathcal{O}_{Re} \mathcal{M}_{prod}^2 d\phi = \int \mathcal{M}_{Re}^2 d\phi + \text{Re}(d_\tau) \int \frac{(\mathcal{M}_{Re}^2)^2}{\mathcal{M}_{SM}^2} d\phi \\ + \text{Im}(d_\tau) \int \frac{\mathcal{M}_{Re}^2 \mathcal{M}_{Im}^2}{\mathcal{M}_{SM}^2} d\phi \\ + |d_\tau|^2 \int \frac{\mathcal{M}_{Re}^2 \mathcal{M}_{d^2}^2}{\mathcal{M}_{SM}^2} d\phi.$$

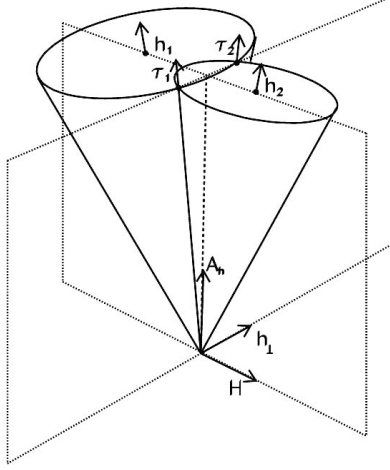

Fig. 2. – Geometrical view of the two kinematical solutions for the tau axis.

The third term drops out because \mathcal{M}_{Re}^2 and \mathcal{M}_{Im}^2 are orthogonal and the fourth term, which includes $\mathcal{M}_{d^2}^2$, can be neglected since d_τ is small.

The mean values of the observables $\langle \mathcal{O}_{Re} \rangle$ and $\langle \mathcal{O}_{Im} \rangle$ are therefore linear functions of d_τ :

$$(10) \quad \langle \mathcal{O}_{Re} \rangle = a_{Re} \cdot \text{Re}(d_\tau) + b_{Re}, \quad \langle \mathcal{O}_{Im} \rangle = a_{Im} \cdot \text{Im}(d_\tau) + b_{Im}.$$

In order to extract the value of d_τ from the observable means measured on the data, we have to know the coefficients a_j and the offsets b_j . The parameters a_j and b_j are extracted from the correlations between $\langle \mathcal{O}_{Re} \rangle$ ($\langle \mathcal{O}_{Im} \rangle$) and $\text{Re}(d_\tau)$ ($\text{Im}(d_\tau)$) extracted by a full Monte Carlo (MC) simulation including the detector simulation with acceptance effects and event selection efficiency. Simulated events with different EDM values are obtained from MC samples weighted by

$$(11) \quad w = \frac{\mathcal{M}_{prod}^2}{\mathcal{M}_{SM}^2} = \frac{\mathcal{M}_{SM}^2 + \text{Re}(d_\tau)\mathcal{M}_{Re}^2 + \text{Im}(d_\tau)\mathcal{M}_{Im}^2 + |d_\tau|^2\mathcal{M}_{d^2}^2}{\mathcal{M}_{SM}^2}.$$

4. – EDM sensitivity and offset

In order to study and optimize the EDM measurement method, several MC sample have been produced and analysed. τ -pairs are simulated with the KK2F MC event generator [16] and subsequent decays of τ leptons are modeled with TAUOLA [17].

The final state in which both τ 's decay hadronically in $\tau^\pm \rightarrow \pi^\pm \nu$ has been analysed. This channel is characterized by the presence of just one charged track for each τ . To calculate the observables of eq. (8) we need to reconstruct the τ^+ and τ^- momentum and the τ^+ and τ^- spin vectors in the τ -pair rest frame, *i.e.* \vec{k} and \vec{S}_\pm in eq. (4)–(6). The complete reconstruction of these quantities is prevented by the presence of undetectable neutrinos.

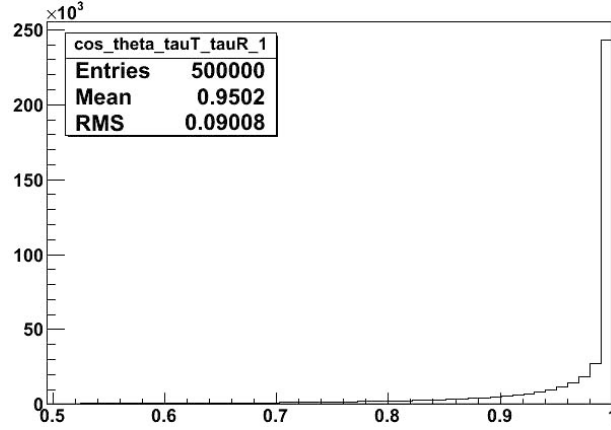

Fig. 3. – Cosine of the angle between one of the two solutions for the τ flight direction and the true one.

4.1. τ momentum reconstruction. – In the case when both τ leptons decay hadronically the τ momentum is calculated with a two-fold ambiguity. For each hadronic decay, the τ flight direction is constrained on the cone around the flight direction of the daughter π with opening angle given by the kinematics of two-body decay. As the taus are produced back-to-back in the CM frame, there are two possible solutions given by the intersection of the two cones. A geometrical view of the two kinematical solutions for the τ axis is shown in fig. 2. Figure 3 shows the cosine of the angle between one of the two solutions obtained for the τ flight direction and the true τ momentum. As expected, in about half of the cases the solution is the correct one. Belle calculated the observables \mathcal{O}_{Re} and \mathcal{O}_{Im} from the matrix elements \mathcal{M}_{SM}^2 , \mathcal{M}_{Re}^2 , \mathcal{M}_{Im}^2 averaged on the two solutions [10].

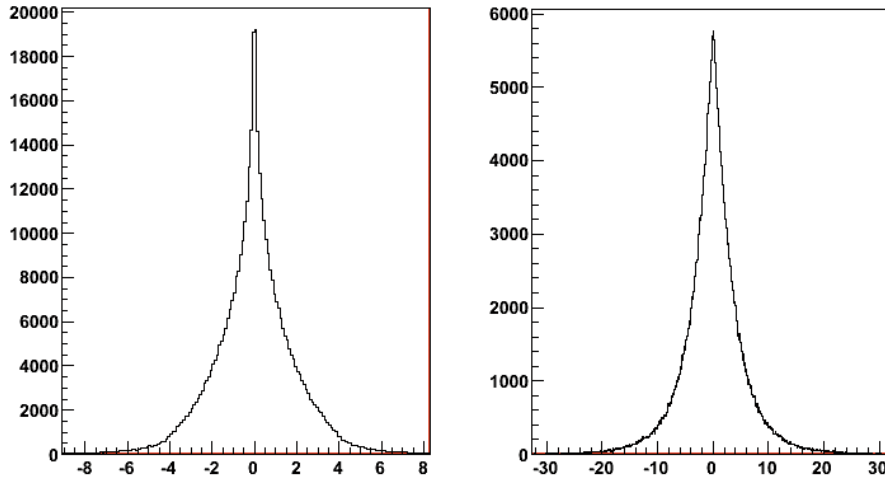

Fig. 4. – Optimal observables distribution for $\tau^+\tau^- \rightarrow \pi^+\pi^-\nu_\tau\bar{\nu}_\tau$ events. Left: \mathcal{O}_{Re} ; right: \mathcal{O}_{Im} .

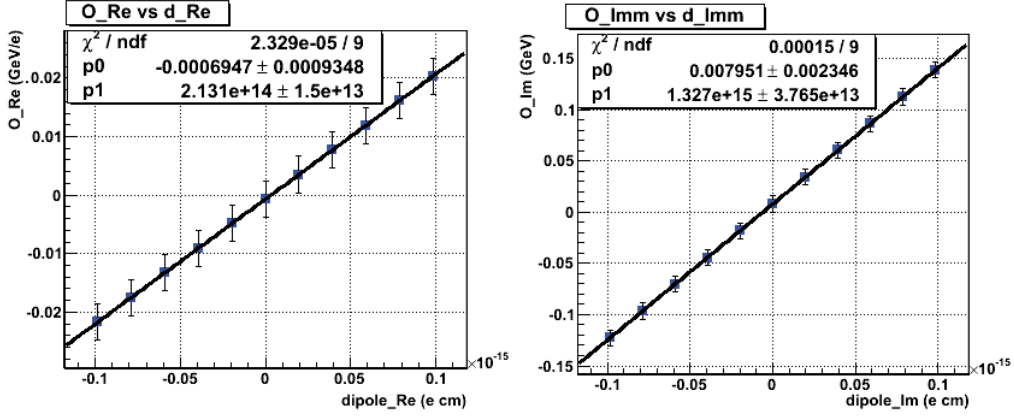

Fig. 5. – Correlation between the observable means $\langle O_{Re} \rangle$ (left) and $\langle O_{Im} \rangle$ (right) and d_τ for the analysed MC sample. Fit results are shown, p0 is the offset b_j and p1 is the slope, corresponding to the EDM sensitivity a_j .

A possible improvement under evaluation in the *BABAR* analysis is to suitably weight the events depending on the opening angle between the two solutions: if this angle is small the average of the two solutions is closest to the true momentum.

4.2. τ^+ and τ^- spin reconstruction. – The spins vectors are calculated from the measured momenta of the charge decay particles and the above-extracted tau flight direction. Spin vectors for the $\tau^\pm(k_\pm, \vec{S}_\pm) \rightarrow \pi^\pm(p_{\pi^\pm})\nu_\tau$ decay mode are given by [18]

$$(12) \quad \vec{S}_\pm = \frac{2}{m_\tau^2 - m_\pi^2} \left(\mp m_\tau \vec{p}_{\pi^\pm} \pm \frac{m_\tau^2 + m_\pi^2 + 2m_\tau E_{\pi^\pm}}{2(E_{\tau^\pm} + m_\tau)} \vec{k}_\pm \right),$$

where all momenta are defined in the τ -pair rest frame.

Distributions of the real and imaginary optimal observables for $\tau^+\tau^- \rightarrow \pi^+\pi^-\nu_\tau\bar{\nu}_\tau$ events, from a MC sample with about the same statistics expected for *BABAR* data, are shown in fig. 4. In this case \mathcal{M}_{SM}^2 , \mathcal{M}_{Re}^2 , \mathcal{M}_{Im}^2 are calculated by averaging over the two possible configurations of the τ momentum.

In fig. 5 the correlations between the observable means $\langle O_{Re} \rangle$ and $\langle O_{Im} \rangle$ and d_τ of this MC sample are shown. By fitting the correlation plots of fig. 5 with eq. (10), the parameters a_j and b_j are obtained. The slopes a_j represent the real and imaginary EDM sensitivity, the offsets b_j represent the difference from zero of the observable mean when $d_\tau = 0$. A non-zero offset is observed for the imaginary part, due to the forward/backward asymmetry given by the collider boost.

The statistical sensitivity (one σ) to the $\text{Re}(d_\tau)$ expected with the full *BABAR* data sample extrapolated from the correlation plot (fig. 5, left) is $0.14 \cdot 10^{-16}$ e cm, one order of magnitude higher than the one reached by Belle. The systematic uncertainties are now under evaluation with the ongoing analysis on the full realistic MC sample with detector acceptance and background effects included.

REFERENCES

- [1] KOBAYASHI M. and MASKAWA T., *Prog. Theor. Phys.*, **49** (1973) 652.
- [2] AUBERT B. *et al.* (BABAR COLLABORATION), *Phys. Rev. Lett.*, **87** (2001) 091801; *Phys. Rev. D*, **66** (2002) 032003.
- [3] ABE K. *et al.* (BELLE COLLABORATION), *Phys. Rev. Lett.*, **87** (2001) 091802; *Phys. Rev. D*, **66** (2002) 032007.
- [4] BERNREUTHER W., BRANDENBURG A. and OVERMANN P., *Phys. Lett. B*, **391** (1997) 413; **412** (1997) 425.
- [5] HUANG T., LU W. and TAO Z., *Phys. Rev. D*, **55** (1997) 1643.
- [6] BERNREUTHER W. and NACHTMANN O., *Phys. Rev. Lett.*, **63** (1989) 2787.
- [7] ACCIARRI M. *et al.* (L3 COLLABORATION), *Phys. Lett. B*, **434** (1998) 169.
- [8] ACKERSTAFF K. *et al.* (OPAL COLLABORATION), *Phys. Lett. B*, **431** (1998) 188.
- [9] ALBRECHT H. *et al.* (ARGUS COLLABORATION), *Phys. Lett. B*, **485** (2000) 37.
- [10] INAMI K. *et al.* (BELLE COLLABORATION), *Phys. Lett. B*, **551** (2003) 16.
- [11] AUBERT B. *et al.* (BABAR COLLABORATION), *Nucl. Instrum Methods A*, **479** (2002) 1.
- [12] BANERJEE S., PIETRZYK B., RONEY J. M. and WAS Z., *Phys. Rev D.*, **77** (2008) 054012.
- [13] GONZALEZ-SPRINBERG G. A., SANTAMARIA A. and VIDAL J., *Nucl. Phys. B*, **582** (2000) 3.
- [14] BERNREUTHER W., NACHTMANN O. and OVERMANN P., *Phys. Rev. D*, **48** (1993) 78.
- [15] ATWOOD D. and SONI A., *Phys. Rev. D*, **45** (1992) 2405.
- [16] WARD B. F. L., JADACH S. and WAS Z., *Nucl. Phys. Proc.*, **347** Suppl. 116 (2003) 73.
- [17] JADACH S. *et al.*, *Comput. Phys. Commun.*, **76** (1993) 361.
- [18] KENJI INAMI, *Precise measurement of the Electric Dipole Moment of the τ lepton at Belle*, (2003) Dissertation at the Graduate School of Science, Nagoya University, Japan.