

**Workshop Report:  
Developing a Research Agenda for the Energy Water Nexus**

NSF Grant Number CBET 1341032

Division of Chemical, Bioengineering, Environmental and Transport Systems  
Sumanta Acharya, *Thermal Transport Processes*  
Bruce Hamilton, *Environmental Sustainability*  
Debra Reinhart, *Environmental Engineering*

**Principal Investigators:**

*Mike Hightower*  
*Sandia National Laboratories*

Danny Reible  
*Texas Tech University*

Michael Webber  
*The University of Texas at Austin*

December 31, 2013

## Report Summary:

The energy water nexus has attracted public scrutiny because of the concerns about their interdependence and the possibility for cascading vulnerabilities from one system to the other. There are trends toward more water-intensive energy (such as biofuels , unconventional oil and gas production, and regulations driving more water consumption for thermoelectric power production ) and more energy-intensive water (such as desalination, or deeper ground water pumping and production). In addition demographic trends of population and economic growth will likely drive up total and per capita water and energy demand, and due to climate change related distortions of the hydrologic cycle, it is expected that the existing interdependencies will be come even more of a concern. Therefore, developing a research agenda and strategy to mitigate potential vulnerabilities and to meet economic and environmental targets for efficiently using energy and water would be very worthwhile.

To address these concerns, the National Science Foundation (NSF) sponsored a workshop on June 10-11, 2013 in Arlington, VA (at NSF headquarters) to bring together technical, academic, and industry experts from across the country to help develop such a research agenda. The workshop was sponsored by NSF Grant Number CBET 1341032 from the Division of Chemical, Bioengineering, Environmental and Transport Systems. Supporting programs were: Thermal Transport Processes, Environmental Sustainability, and Environmental Engineering.

The results of the workshop are presented in this report, which is organized as follows:

- 1) Discussion of the objectives of the workshop
- 2) Overview and background of the energy-water nexus
- 3) Summary of events at the workshop
- 4) Highest priority research directions identified at the workshop
- 5) Appendix: inventory of research needs identified at the workshop
- 6) List of participants
- 7) Workshop presentations

The workshop considered four perspectives on the energy-water nexus:

- (1) Managing water demand for the production of power (water for power),
- (2) Managing water demand for the production of fuels (water for fuel),
- (3) Managing the energy demands of extracting, treating and transporting water (energy for water), and
- (4) Managing social, behavioral, policy, communications, collaborator, and economic structures to enhance water and energy use efficiencies.

Research opportunities and needs were identified for each of those four topics and are summarized in this report. Appendix A includes a comprehensive list of research needs and directions based on the input from attendees at the workshop held in June. Section 4 summarizes the different opportunities and needs into a short list of recommendations that

the PIs and the workshop attendees believe have the highest priority because they are likely to have the greatest positive contribution. Those high-impact strategic priorities are as follows:

- 1) **Developing decision support tools:** Cross-platform, multi-user, multi-resource, multi-timescale, and multi-spatial-scale modeling platforms to aid decision-making
- 2) **Solving data issues:** Creating curated, validated, up-to-date datasets at multiple temporal and spatial scales
- 3) **Cross-sectoral systems integration:** Using the water sector to solve the energy sector's problems, and using the energy sector to solve the water sector's problems
- 4) **Source switching:** Alternative water sources that use less energy and compete less with freshwater and alternative energy sources that use less freshwater
- 5) **Advanced technologies:** Low energy water technologies, low water energy technologies
- 6) **Smart technologies:** Embedding information with resources
- 7) **Improved market structures:** Developing efficient and highly functional markets (especially for water)
- 8) **Advanced materials:** Better materials are valuable throughout the different dimensions of the energy-water nexus and enable other innovations
- 9) **Integrated policymaking:** Avoid isolated policymaking via improved professional community engagement, education, and communication vehicles

In addition to these different strategic research directions, it was also recommended that NSF collaborate with other relevant agencies (DoE, USGS, EPA, USDA, DHS, DoD, NASA, etc.) to perform cooperative research that spans multiple disciplines, spatial scales and timescales.

## Table of Contents:

<b>1) Objectives of the Workshop:</b> .....	<b>5</b>
<b>2) Overview and background of the energy-water nexus</b> .....	<b>6</b>
Introduction .....	6
Background on water for power .....	7
Background on water for fuels.....	9
Background on energy for water .....	10
Background on communication, societal influences, and professional organizations .....	11
<b>3) Summary of events at the workshop</b> .....	<b>12</b>
<b>4) Highest Priority Research Directions</b> .....	<b>15</b>
<b>References</b> .....	<b>20</b>
<b>Appendix A: Comprehensive Inventory of Research Needs Identified at the Workshop</b> .....	<b>21</b>
Research Needs I: Water for Power Production.....	21
Research Needs II: Water for Fuels Production.....	29
Research Needs III: Energy for Water.....	32
Research Needs IV: Communications, Social and Behavior.....	36
<b>Appendix B: List of Participants (with roles noted: speaker, organizer, facilitator, rapporteur)</b> .....	<b>41</b>
<b>Appendix C: Workshop Presentations</b> .....	<b>45</b>

## 1) Objectives of the Workshop:

This workshop sought to facilitate networking and coordination among professional organizations (particularly engineering societies), practitioners, and researchers addressing energy-water nexus concerns and issues. The goal of the workshop was to generate a coherent research agenda that can be used to overcome infrastructure, technical, and societal challenges to implementing solutions that address and mitigate emerging energy-water nexus problems. The workshop sought to identify research pathways for reducing the water-intensity of providing energy, and the energy-intensity of providing water.

The four main specific topics for attention were:

- (1) Managing water demand for the production of power (water for power),
- (2) Managing water demand for the production of fuels (water for fuel),
- (3) Managing the energy demands of extracting, treating and transporting water (energy for water), and
- (4) Managing social, behavioral, policy, communications, collaborator, and economic structures to enhance water and energy use efficiencies.

The workshop sought to identify the barriers to technology acceptance (whether technical, economic or social) and the research necessary to overcome those barriers. The topics of discussion included systems integration, materials, component design, information technology, improved processes, social and behavioral sciences, economics, and policy and regulations. The workshop was organized around introductory talks in each of the theme areas outlining the key challenges and opportunities as they now exist and to provoke further thinking and discussion on current and future needs and how they might be addressed. Then, the workshop moved to small breakouts, with highly engaged participants submitting their input in facilitated sessions.

The workshop attracted more than 125 participants from a cross-section of industry (technology developers and practitioners), academia (researchers), national labs (researchers), professional organizations (facilitators) and government (regulators and policymakers). These attendees are noted in the Appendix.

The industry representatives were invited from the water sector and the energy sector. Companies include major construction companies who build large infrastructure (such as power plants and water reservoirs), as well as technology companies who make devices, appliances and components (such as filters, membranes, pumps, etc.). Members of both energy and water industry associations and professional societies were also invited.

Academic representatives were invited from a range of disciplines and with geographic diversity. Disciplines prioritized engineering, but also included natural scientists and social

scientists as well. Researchers from national labs were also invited, as many of them have been at the forefront of research on this topic.

Professional organization representatives were invited from professional societies interested in and active in supporting energy-water nexus issues. This includes, among others, the American Institute of Chemical Engineers (AIChE) and its water-oriented member organization, the International Society of Water Solutions (ISWS), the American Society of Mechanical Engineers (ASME), Academy of Environmental Engineering and Science Professors (AEESP), American Institute of Mining, Metallurgical and Petroleum Engineers (AIME), the Society of Petroleum Engineers, SPE, Institute of Electrical and Electronics Engineers (IEEE), American Society of Civil Engineers (ASCE), Air and Waste Management Association (AWMA), and the Water Resources Network from Engineers for Sustainability (EFS). By inclusion of representatives from these organizations the workshop sought to aid coordination and communication among the societies and networking between the societies and researchers, practitioners and government agencies. As noted later in this summary, professional societies can be an effective tool to communicate the messages from the workshop to the broader community.

Government agency representatives at the federal, state and local levels were also invited as their input on policymaking and on-the-ground implementation of rules are key pieces to the puzzle. The workshop was held in the greater metropolitan area of Washington DC to aid participation by federal agency personnel. In addition to being participants in the workshop, the government representatives were also one of the main audiences for the outcomes of the workshop.

## 2) Overview and background of the energy-water nexus

### Introduction

Energy and water are closely interrelated. Because of these interdependencies, each sector is vulnerable to the other sector's failures.[IEA, 2012] Moreover, the trends towards more energy-intensive water (from desalination, falling water tables, long-haul transfers, and stricter treatment standards) and more water-intensive energy (including biofuels, carbon capture, and unconventional fossil fuels) means that these problems might be exacerbated.

Water is used extensively in energy development as cooling water in thermoelectric power generation; in refining or upgrading oil and alternative transportation fuels; for hydropower; and in biofuels production. Significant volumes of water are needed to produce the fuels required for power generation as well as for cooling of the power plants. Coal and uranium mines often have to be dewatered prior to production, and water is used for dust control and for leaching out the desired materials. Waterflooding and injection is used to pressurize reservoirs for extracting oil and gas for conventional production. Unconventional production techniques such as hydraulic fracturing require 2 to 9 million

gallons of water per well for stimulating fissures in the shale formations, returning anywhere from 15% to 300% of the injected water as wastewater (comprised of drilling muds, flowback water and produced water).[Nicot, 2012; Mantell, 2013; Lutz, 2013] Irrigated crops of first-generation biofuels are as much as three orders of magnitude more water intensive than conventional petroleum-based fuels [King, 2008] and additional water is needed to process these raw materials into fuels. These concerns have led many researchers and energy and water policy and management administrators to identify improving water use efficiency in electric power generation and in transportation fuel production, processing, and refining as a major need and challenge.

Water and wastewater pumping, treatment, and distribution is also one of the larger energy use sectors for many municipalities and in many developed countries, which means alternative water supplies might exacerbate the tensions at the energy-water nexus. At a time when fresh water availability is becoming limited in many regions due to changing precipitation patterns, increased ecological and environmental concerns, and demands for water, the impact on water resources by energy development deserves greater attention. Viewing these issues through a lens of sustainable surface water and groundwater withdrawal and use only complicates matters further.

## Background on water for power

Water withdrawals for thermoelectric power generation accounts for almost 50 percent of all daily water withdrawals in the U.S. While the amount of water consumed is much less, it still accounts for 22 percent of all non-agricultural daily water consumption in the U.S. [USGS, 2009] Since much of the projected growth in electric power demands will be in regions of the country with already limited water supplies, such as the Southeast, Southwest, and West, reducing water use and particularly fresh water consumption in future electric power generation will be an important (but difficult) challenge.

Traditional approaches to electric power generation often require a significant amount of water, with most of this water consumed to provide cooling water for steam condensers, though some water is also consumed by other plant functions such as air emission reductions. About 50 percent of current U.S. generating capacity is thermoelectric generating stations using open-loop cooling [EIA 2011]. In open-loop cooling systems, water is warmed as it passes through the cooling system, but it is not evaporated in the cooling system. Open-loop cooling requires access to a large body of water such as lakes, reservoirs, large rivers, the ocean, or estuaries for water withdrawal. Aquatic life can be adversely affected by impingement on intake screens and entrainment in the cooling water, and by the discharge of warm water back to the source. During periods when drought or other circumstances lead to water levels or water temperatures outside of design limits, such as recent droughts in the Southeast in 2009 and Texas in 2010, power-plant operations can be restricted.

Where access to large surface water bodies a constraint, closed-loop evaporative cooling is typically used. Most thermoelectric plants installed since the mid-1970s are cooled in a “closed” loop by evaporation of the cooling water in a wet cooling tower or cooling pond.

These systems withdraw less than 5 percent of the water withdrawn by open-loop systems, but most of the water withdrawn is consumed through evaporation. Evaporation of water concentrates contaminants, including water treatment additives, so the concentrated waters or blowdown from these systems can require treatment before release.

Other water uses in fossil-fired steam plants is for emissions control, such as flue gas desulfurization. While not all plants use wet scrubbing for flue gas removal, emissions control can add another 10% to water withdrawal and consumption in some power plants. [Grubert, 2012] Additionally, the emerging consideration of sequestering carbon emissions will have a large impact on water consumption for fossil fueled power plants. Carbon sequestration requires energy and decrease net plant output by as much as 25%. As a result, water requirements for these plants can increase by more than 80% [NETL 2010].

The second-largest source of electric power (after thermal power plants) in the U.S. is hydroelectric power, which produces from six percent to ten percent of U.S. electricity generation depending on streamflow variability. A significant amount of water is lost by evaporation from reservoirs associated with hydroelectric plants, but since hydroelectric power is not the primary function of most these reservoirs (they also provide for irrigation, navigation and recreation), decreasing hydroelectric power production would not necessarily reduce water losses. However, increasing the efficiency of hydroelectric operations could yield more power from these reservoirs without increasing water losses, replacing power from other water-consuming power plants, such as thermoelectric plants.

Beyond conventional hydroelectric power, other renewable energy sources, including non-conventional hydropower, wind, solar, and geothermal energy systems, today account for the remaining few percent of the nation's electricity generation. But solar photovoltaic, solar dish-engine, wind, and air-cooled geothermal hot water (binary) power systems offer a significant advantage over other electricity generation technologies in that they consume no water at the point of electricity production. While these renewable energy power plants use modest amounts of water, solar-thermal and non-air-cooled geothermal power plants often use somewhat higher amounts of water than conventional thermal plants because of their lower thermodynamic efficiencies, which means they need to reject more waste heat through cooling water vaporization. The cost and intermittency of the low water-use renewable energy technologies has been a barrier to their increased use. Therefore, ways to improve the integration of these renewable technologies more reliably is important to help in reducing future water demands of the electric power sector.

Growing environmental requirements to reduce the ecological and climate impacts of thermoelectric power plants could significantly increase water use and/or consumption to better protect aquatic ecosystems and capture and sequester or reutilize air emissions. While options exist to help minimize water use and consumption, currently they often create a loss of system efficiency or increase costs, and the barriers to implementation of more efficient and cost-effective options must be explored.



## Background on water for fuels

Transportation fuels currently used in the United States are primarily derived from petroleum, of which about 50 percent is imported. In order to reduce dependence on imported oil, the U.S. has developed initiatives to assess and develop alternative transportation fuels from domestic supplies such as biomass, oil shale, coal, and natural gas from coal-bed methane and shale reservoirs. The scale-up of the alternative fuels production needed to keep oil and petroleum imports constant is projected to require up to 8 million barrels per day of alternative fuels by 2035. [EIA, 2013]

Alternative transportation fuels include renewable biofuels, fuels refined from non-renewable crude oils produced from oil shale, oil sands, shale reservoirs, and non-renewable synthetic liquid fuels derived from coal and natural gas. Also of longer-term interest are hydrogen from fossil and biomass sources, from the electrolysis of water using wind or solar power, or from nuclear power. Biogas (primarily methane) produced from the anaerobic digestion of agricultural wastes and the organic fraction of municipal solid wastes is also a form of biofuel that can be used for the generation of electrical power and heat. The refining of conventional gasoline and diesel fuels consumes about 1.5 gallons of water for every gallon of fuel produced [Gleick, 1994].

Significant efforts are underway to advance biofuel production from various forms of biomass. Research and development is continuing on conversion technologies and processes to improve biofuel production efficiencies and reduce costs. Biofuels production is currently experiencing the most rapid growth and interest relative to all alternative fuel options, with starch grain (primarily corn-based) ethanol production exceeding the Renewable Fuels Standard targets set by the Energy Policy Act of 2005. However, these biofuels are relatively water intensive. Biofuels based on conversion of lignocellulosic biomass, which are nominally less water intensive, are also mandated to meet volumetric goals. The successful development and commercialization of emerging lignocellulosic conversion processes and technologies is of growing interest for building a broader biorefining capacity to convert biomass into biofuels and numerous other products.

Water is directly used and consumed within various input feedstock and intermediary product development, conditioning, conversion, separation, and cooling processes associated with all the alternative transportation fuels as well as with oil shale refining. Water-related issues are beginning to be noted in many of these efforts, and only recently has attention begun to be placed on the relationship between biofuels and water quality and on the broader water quantity implications of biofuels and other alternative fuels production like fracing and the associated produced water. [Grubert, 2012; Nicot, 2012; Lutz, 2013; Twomey, 2010] Fuels derived from biofuels, coal, natural gas, oil shale, and oil sands are expected to be in the range of three to six times more water use-intensive than conventional petroleum based fuels. Water use for biofuels development can be even greater, depending on whether irrigation is used for the biomass feedstock production

Water quantity and quality issues are closely tied to both energy feedstock production and the conversion processing associated with each of the alternative fuels being considered. Future alternative fuels development and production, based on current and projected approaches and processes, will increase demand on fresh water resources relative to current water consumption. The regional production and refining nature of many of these alternative fuels, especially biofuels and shale oils and gases, suggests that these increased water demands will have larger impacts in some regions and could pose significant competition for available regional water supply resources in regions with already limited water supply availability.

### Background on energy for water

The corollary to the discussions above is that the water system is very energy-intensive. Recent research though has identified that the water system end-to-end is responsible for more than 12% of national energy consumption [Sanders, 2012]. That energy is used for conveyance, treating, distributing, heating, pressurizing, chilling and remediating water.

This fraction is likely to grow as we exploit poorer quality sources of water such as seawater, saline groundwater, and reuse and recycle industrial and domestic wastewater to meet growing water demands. For example, wastewater reuse in the U.S. is growing at 15 percent a year and desalination is growing at 10% per year. These two technologies currently require two to ten times more energy per unit of water treated than traditional water treatment technologies. This trend highlights the growing energy needs just for treating nontraditional water resources to drinking water quality.

On the wastewater side, emerging regulations for treating waste water resources to stricter effluent standards are increasing the energy needs for waste water to comply to new water quality standards. This outcome occurs because many current water disinfection approaches, such as chlorination, which does not use much energy, are being replaced by very high energy use UV systems to reduce the formation of harmful disinfection by-products. Also, the movement towards treatment of minerals in water such as arsenic and endocrine disruptors to levels in the low parts per billion range mean that only high energy demand water treatment technologies will be feasible.

Based on these trends, many evaluations have been made on the level of additional electric power that will be required to meet these water treatment demands. Many of these evaluations suggest that new treatment regulations, new water treatment approaches, and the new water needs could drive upwards the water and waste water sector's electric power demand, ultimately making it one of the nation's largest electricity consumers within the industrial sector.

## Background on communication, societal influences, and professional organizations

In addition to the required technical advances, barriers to communication are key hurdles to overcome for a successful resolution of problems at the energy-water nexus.

Communications efforts should include outward-facing (from the scientific community out to stakeholders including policymakers and the general public) and inward-facing (within the scientific community) thrusts to facilitate collaboration among research and successful uptake by markets and regulators. The professional societies are an effective fulcrum for these communications activities.

Consequently, professional organization representatives were invited from societies interested in and active in supporting energy-water nexus issues. These included, among others, the American Institute of Chemical Engineers (AIChE) and its water-focused member organization, the International Society of Water Solutions (ISWS), the American Society of Mechanical Engineers (ASME), Academy of Environmental Engineering and Science Professors (AEESP), American Institute of Mining, Metallurgical and Petroleum Engineers (AIME) (including the Society of Petroleum Engineers, SPE), Institute of Electrical and Electronics Engineers (IEEE), American Society of Civil Engineers (ASCE), Air and Waste Management Association (AWMA), the Electro Chemical Society (ECS), the Water Environment Federation (WEF) and the Water Environment Research Foundations (WERF), American Water Works Association (AWWA), and the Water Resources Network from Engineers for Sustainability (EFS).

By inclusion of representatives from these organizations in the workshop activities, the organizers sought to aid collaboration, coordination, and communication among the societies and initiate networking between the societies and researchers, practitioners and government agencies. This was not a difficult effort in that many of the professional societies, universities, and federal and state agencies have been looking at these energy and water issues as they impact their constituents. For example, ASME has had a program looking at energy water issues specifically in the power sector and the process industries sector for over three to four years. AIChE has been looking at energy water issues in the chemical refining, processing, and manufacturing area and the associated impacts and recently formed the ISWS to focus attention on the issues of industrial water management. ASCE, AWWA, and WEF and WERF have been facilitating reducing energy demands in the water and wastewater sector.

### 3) Summary of events at the workshop

The workshop was structured with a sequential agenda, tackling each of the four topics in order, and using a plenary session and 3 to 4 parallel breakouts for each topic. The plenary session included two 30-minute presentations designed to introduce the topic and provide an overview of the challenges in each area. The breakouts were designed to explore these challenges and research needs and opportunities in more detail in a 1.5-hour session. Attendees also met as a group after each breakout session to report back on the findings from the breakouts.

The discussion of the four topics was organized to require two days to complete. For each topical area, each of the four breakout sessions was led by a facilitator and included at least one student rapporteur. At the end of the discussions on each topic, the information from the four sessions was combined to create a final list of the appropriate and highest priority research gaps and issues identified and selected (summarized in the next section). At the end of day two, the workshop closed with a brief, final session to report back the important priorities identified by the participants over the two day workshop.

In total, 129 participants registered to attend, and there were 12 speakers, 12 facilitators, and 8 rapporteurs. The workshop started with four opening talks including talks by Dr. Pramod Khargonekar (NSF), Dr. Danny Reible (Texas Tech University), Dr. Holmes Hummel (DoE), and Dr. Michael Webber (The University of Texas at Austin). Following these opening remarks, the agenda moved into individual sessions on each of the four topics. Each topic discussion was preceded by two opening talks with related key information and existing challenges, followed by the parallel breakout sessions that were facilitated and had rapporteurs.

The breakout sessions were intentionally designed to identify challenges and solicit input on way to address not only the technical challenges, but also the social and policy challenges at the energy water nexus. These are areas that are typically overlooked by purely technical workshops. But this workshop was intentionally designed to look at the ways that the social and political sciences could be included to help address some of these emerging energy and water issues.

The Agenda developed for this NSF workshop was as follows:

June 10, 2013:

7:00 to 8:00 Registration: Building access and badge collection

### **Opening Session:**

- 8:00 to 8:05 Welcoming remarks by Pramod Khargonekar, Assistant Director for the Engineering Directorate, NSF
- 8:05 to 8:15 Opening remarks: Danny Reible (Texas Tech)
- 8:15 to 8:45 *Keynote: Federal contributions to problem-solving at the energy-water nexus:* Holmes Hummel (Senior Policy Advisor, DOE)
- 8:45 to 9:00 Objectives, structure, and admin details of the meeting: Danny Reible (Texas Tech)
- 9:00 to 9:45 *Overview of Energy-Water Nexus:* Michael Webber (UT)
- 9:45 to 10:00 Break

### **Session I: Water for the Power Sector**

- 10:00 to 10:30 *Water Use and Consumption in Electric Power Generation Approaches:* Mike Hightower (Sandia)
- 10:30 to 11:00 *Water and the Electric Power Sector:* Bob Goldstein (EPRI)
- 11:00 to 12:30 Breakouts (three groups) to discuss specific topics in the area of barriers (technical, social, and policy) for implementing solutions
- 12:30 to 2:00 Lunch on your own

### **Session II: Water for Fuels Production**

- 2:00 to 2:30 *Water for Biofuels: Implications for Energy, Food and Environment:* Ximing Cai (University of Illinois & Urbana-Champaign)
- 2:30 to 3:00 *Energy & Water:* Roland Moreau (ExxonMobil)
- 3:00 to 4:30 Breakouts (three groups) to discuss specific topics in the area of barriers (technical, social, and policy) for implementing solutions
- 4:30 to 5:00 Report back to group from Session I & II
- 5:00 Dinner on your own

June 11, 2013:

**Session III: Energy for Water**

- 8:30 to 9:00 Water and Energy: The Case for Distributed Water Treatment and Desalination Systems: Yoram Cohen (UCLA)
- 9:00 to 9:30 Developing Sustainable Energy Solutions in the Water Industry: Ralph Eberts (Black and Veatch)
- 9:30 to 11:00 Breakouts (three groups) to discuss specific topics in the area of barriers (technical, social and policy) for implementing solutions
- 11:00 to 11:15 Break
- 11:15 to 11:45 Report back to group on Session III breakouts
- 11:45 to 1:00 Lunch on your own

**Session IV: Reporting back and Social, Behavioral, Policy and Communications Issues**

- 1:00 to 1:30 Outreach and Engagement: The Importance of Communication in Maximizing Water-Energy Research Investments: Lorraine White (GEI Consultants)
- 1:30 to 2:00 Professional Society Support of Energy Water Nexus: Discussion of Models for Leverage and Cooperation: Darlene Schuster (AIChE)
- 2:00 to 3:30 Breakouts to discuss specific topics in the area of social, behavioral, policy and communications issues. One group will be focused specifically on enhancing communication and coordination among professional organizations to aid in the translation of the lessons learned from the workshop to the broader society membership.
- 3:30 to 4:00 Rapporteurs and facilitators from each breakout will report back their findings to the broader group. Plus, there will be an opportunity to discuss communications strategies.
- 4:00 to 4:15 Closing comments from organizers and NSF
- 4:15 Adjourn

## 4) Highest Priority Research Directions

The many ideas for research directions and priorities identified during the breakouts are collected in an inventory from the rapporteurs' notes in Appendix A. Of all those excellent ideas, there were a few areas that were particularly critical, meaning that they were mentioned in multiple breakouts or are enabling for other innovations. These highest-priority research directions that are cross-cutting across the various topics of the energy-water nexus are listed below and then described in more detail.

- 1) **Developing decision support tools:** Cross-platform, multi-user, multi-resource, multi-timescale, and multi-spatial-scale modeling platforms to aid decision-making
- 2) **Solving data issues:** Creating curated, validated, up-to-date datasets at multiple temporal and spatial scales
- 3) **Cross-sectoral systems integration:** Using the water sector to solve the energy sector's problems, and using the energy sector to solve the water sector's problems
- 4) **Source switching:** Alternative water sources that use less energy and compete less with freshwater and alternative energy sources that use less freshwater
- 5) **Advanced technologies:** Low energy water technologies, low water energy technologies
- 6) **Smart technologies:** Embedding information with resources
- 7) **Improved market structures:** Developing efficient and highly functional markets (especially for water)
- 8) **Advanced materials:** Better materials are valuable throughout the different dimensions of the energy-water nexus and enable other innovations
- 9) **Integrated policymaking:** Avoid isolated policymaking via improved professional community engagement, education, and communication vehicles

Each of these different high priority research thrusts is described in turn below.

**Developing decision support tools and more capable modeling tools:** The need for sophisticated decision-support tools were called for in the opening keynotes and in each breakout session. Today's planners and decision-makers lack the tools to evaluate the impacts of different energy and water scenarios. Thus, policies are often made without sufficient scientific input. In particular, the cross-sectoral impacts are missing. Thus, the water impacts of energy decisions and the energy impacts of water decisions remain difficult to predict. When developing these tools, it is important that they are functional in a way to enable modeling that is cross-platform, multi-user, multi-resource, multi-timescale, and multi-spatial-scale. These modeling tools should be built in a way that is consistent with prevailing datasets (see below) and that is robust across a variety of

computing platforms. This research area, along with the need for better data (see below), was one of the two most important research priorities identified at the workshop.

***Solving Data Issues:*** Because the existing available data for water are inaccurate, limited in resolution, and outdated, they inhibit the ability to accurately model, predict and manage resources. Thus, there is a significant need for better data and better sharing of those datasets. Generally speaking, the data for energy are in much better condition than the water data, as energy data in the United States are available from the EIA mostly for free, with excellent temporal resolution (at least annually, but also weekly in many cases, and hourly or better by some grid operators), distinction by the various fuels, and with geographic resolution. By contrast, the water are particularly poor. Thus, most of this recommendation about making data available is pertinent for water.

In particular, shared data sets are sought that meet the following criteria:

1. Validated,
2. Reported with consistent naming conventions, boundaries, and parameters,
3. Available via a robust, user-friendly public data portal, and
4. Compiled from existing energy-water data from various studies; in particular, the data already collected in five regional workshops could be leveraged as a starting point.

It is important that these data can ultimately be incorporated (with effective assumptions) into decision support tools (see above) to aid decision-making under uncertainty. Thus, a framework for the data needs to be established. Furthermore, there are specific data elements that are needed for strategic planning, modeling, and analysis:

1. National water usage (non-consumptive and consumptive, updated on a monthly timescale or better),
2. National water quality (by location and time),
3. Evaporation downstream of open cooling plants not included in EIA collected datasets,
4. Intersection with other sectors, and
5. Better inventories of water evaporation from energy use (for example, from hydroelectric systems, from cooling towers, from thermal pollution downstream of power plants, etc.).

Another key aspect about data is the need for real-time data collection. In addition to better archiving and collection schemes for monthly or annual information, development of sensors for *in-situ* and real-time data collection would be very valuable for the scientific community and for policymakers. This research area, along with the need for better modeling (see above), was one of the two most important research priorities identified at the workshop.

***Cross-sectoral systems integration:*** Each breakout session called for better integrated systems engineering, design, and research. This point is important because most research agencies are designed to fund research on individual components, devices, or



methodologies. That is, no agency supports integrated systems research as a central component of its funding program. And, integrated systems proposals have a particularly difficult time surviving traditional NSF review panels because they are typically more applied (rather than fundamental) in that they are designing a system that incorporates existing elements. Thus developing a government R&D funding model that supports systems work is an important priority.

The main idea behind integrated systems research for cross-sectoral problem-solving is that the water sector can be used to mitigate problems in the energy sector, and the energy sector can be used to mitigate problems with the water sector. For example, intermittent renewable energy sources can be used for desalination of brackish ground water. One of the big challenges with wind and solar is that both resources are intermittent in nature. However, desalination can be performed in an intermittent way to match the availability of the power, mitigating its impact on the grid. One of the big challenges with desalination is its high marginal energy cost and carbon intensity. Because the marginal energy cost and carbon intensity of wind and solar is very low, they mitigate this challenge of desalination. Thus, by integrating wind and/or solar with desalination, they both solve each other's problems. Two low-value products (intermittent electricity and salty water) are turned into one high-value product (treated water). Other examples include changes to cooling systems in the power sector to free up resources for the water sector, or changes to water distribution systems (to include purple water piping) to free up resources in the power sector. Other examples include using variable frequency drives in the water sector as dispatchable load that can be used for grid balancing in the power sector.

Research into these types of integrated systems is vastly underfunded. Furthermore, these projects are often multidisciplinary, which means that they do not align well with any one individual program office. Consequently, it is highly recommended that the NSF and other funding agencies develop mechanisms for fostering integrated systems research. Optimal integration of different solutions to make an effective system often includes multiple engineering disciplines, plus economics, policy, business, or other factors. Because integrated systems are often difficult to pilot in hardware form (because they include more components, driving up price), it is expected that a significant body of integrated solutions will be analytical in nature at least for the initial scoping studies.

**Source switching:** Another general approach that was identified as valuable to each of the different dimensions of the energy-water nexus is the use of alternative sourcing. For example, switching from highly treated drinking water to water sources such as treated effluent, graywater, harvested rainwater, etc. would save energy and would compete less with freshwater. In the built environment, graywater, purple water and rainwater can be used for irrigation, flushing toilets, and so forth. In oil and gas production, water reuse, brackish water and effluent can be used for hydraulic fracturing instead of virgin freshwater.

Furthermore, there are alternative energy sources that use less water. For example, switching from nuclear to wind power generation avoids significant water needs at the point of generation because it does not need water cooling.

While source switching is an effective approach for mitigating problems at the energy-water nexus, it is also plagued by a variety of technical/performance, social, economic and policy barriers. Thus, the research agenda on this point should be focused on overcoming barriers to the widespread use of energy and water substitutes in energy. For example, some cities ban the use of greywater, even for non-potable uses. Conducting research to develop the technologies that are needed and to illustrate the environmental and economic benefits of using alternative sources is recommended as a fruitful research pathway.

***Advanced technologies:*** There is significant need for technology development at the materials, component, device, and software levels that reduce the energy intensity of water and the water intensity of energy. In particular, low-water cooling systems for thermal power plants was identified as a high priority. Those technologies might include novel power cycles, advanced materials or coatings, new heat exchanger designs, and so forth. Advances in this area would be critical for improving the performance and robustness of power plants in spite of water constraints from droughts or heat waves. Furthermore, those cooling advances might have cross-over benefit to other segments in society, for example in HVAC systems in the built environment.

Other opportunities include technologies for reducing the water needs of oil and gas production. For example, waterless fracturing for shale production, or new techniques for on-site water treatment and reuse. Reducing the energy for water is also valuable. Approaches might include better membranes (with less fouling) for water treatment and desalination, more efficient water pumps, variable frequency drives for pumps/fans, and so forth.

***Smart technologies:*** Technologies that embed information with the resources were also identified as a key research priority. While the “smart grid” has become a cliché concept, the same idea of using information that is highly resolved by time-of-day, location, and use, is also valuable for natural gas and water. This research effort is synergistic with the priority identified above about solving the data gap. There is a need to develop more instrumentation, sensors, and communications protocols and capabilities for more closely tracking resource consumption. For example, 10-40% of treated water leaks between the treatment plant and the end user. Building a smarter infrastructure (with sensors all along the way) would enable maintaining a better inventory of the resource, including identification of leaks and losses. With that information, the system could also be fine-tuned to operate in a more optimal way. At the end-user, information on water consumption is available on a monthly basis with no distinction by use, type of water or time of day. However, it would be valuable to track water use in homes and businesses to distinguish indoor vs. outdoor, heated vs. unheated, treated vs. graywater, and so forth.

In addition to hardware and infrastructure systems that would be necessary, the “smart technologies” research area also opens up the door for ground-breaking research on data management, algorithms, and optimal process control.

**Improved market structures:** Another consistent theme of the workshop was the pressing need for developing and implementing efficient and highly functional markets. These markets should operate with clear rules and performance standards (for example, emissions standards for tailpipes or smokestacks), and should have more resolution. Within the electricity sector, time-of-use pricing was identified as a valuable enabler for opening up new market opportunities for sophisticated technologies. For example, with finer temporal resolution in the consumer electricity markets, there will be a need for smarter appliances, advanced control systems, and better methodologies for predicting emissions.

The water markets—which are highly regulated and dysfunctional—in particular were identified as in need of major overhaul. Because water prices are below the true value of water for many end users, there is little incentive to innovate or adopt new technologies. Establishing a framework and methodology for valuation of water is a critical need.

Thus, there is a significant need for extensive research into different market designs, and the economic, resource, and environmental impacts of varying market structures. This research would be inherently multidisciplinary, as it requires input from engineers, social scientists, economists, and business experts.

**Advanced materials:** Better materials were identified throughout as a critical enabler for advances. Better materials and coatings for heat exchangers in power plant cooling systems would reduce water for energy. Better membrane materials and coatings at treatment plants would reduce the energy needed for water treatment. Extensive research is needed for materials advances that are geared towards problems at the energy-water nexus.

**Integrated policymaking:** One problem is that policymaking for energy and water are often done in isolation from each other. However, integrated policymaking would offer significant benefit. Achieving that shift would likely require improved professional community engagement, education, and communication vehicles. Thus, support for improved energy and water literacy, along with policy analysis were identified as key areas. These topical areas include improved cross-sectoral life-cycle analysis methods. And, new teaching tools and curriculum need to be developed for direct instruction, public education, and outreach to policymakers.

## References

- EIA, 2012. *Form 923 – Environmental Equipment*. Energy Information Administration, U.S. Department of Energy.
- EIA, 2013. *Annual Energy Outlook 2013*. Energy Information Administration, U.S. Department of Energy.
- IEA, 2012. *World Energy Outlook 2012*, International Energy Agency, 2012.
- Gleick, 1994. Gleick, Peter "Water and Energy." *Annual Review of Energy and the Environment* 19:33 (1994).
- Grubert, 2012. E.A. Grubert, F.C. Beach and M.E. Webber, "Can switching fuels save water? A life cycle quantification of freshwater consumption for Texas coal- and natural gas-fired electricity," *Environmental Research Letters* 7 045801 (2012).
- King, 2008. C.W. King and M.E. Webber, "Water Intensity of Transportation," *Environmental Science and Technology*, **42**(21), pp 7866-7872 (7pp) (September 24, 2008).
- Lutz, 2013: B.D. Lutz, A.N. Lewis and M.W. Doyle, "Generation, transport, and disposal of wastewater associated with Marcellus Shale gas development," *Water Resources Research* (2013).
- Mantell, 2013. M. Mantell, Chesapeake Energy, private communication (February 2013).
- NETL, 2010. *Water Vulnerabilities for Existing Coal-fired Power Plants*. DOE/NETL-2010/1429.
- Nicot, 2012: Nicot, J.-P. and Scanlon, B.R., Water Use for Shale-Gas Production in Texas, U.S. *Environ. Sci. Technol.* (2012) 46 (6), 3580-3586.
- Sanders, 2012. K.T. Sanders and M.E. Webber, "Evaluating the energy intensity of water in the United States," *Environmental Research Letters* 7 034033 (2012).
- Twomey, 2010. K.M. Twomey, A.S. Stillwell, and M.E. Webber, "The Unintended Energy Impacts of Increased Nitrate Contamination from Biofuels Production," *Journal of Environmental Monitoring* **12** (2010).
- USGS, 2009: *Estimated Use of Water in the United States in 2005*. Technical report, U.S. Geological Survey, 2009. Circular 1344.

## Appendix A: Comprehensive Inventory of Research Needs Identified at the Workshop

As noted, the workshop's objective as to be solutions-oriented by integrating fundamental research in the technical sciences with the social and behavioral sciences within the context of a changing regulatory and planning environment and shifting water and energy market supply and demand dynamics. Many efforts to look at energy and water issues have been technology focused, only looking at technical research and innovation. And even further, many of the efforts focus in only one technical area, such as only technologies to reduce water use in electric power, or only technologies to reduce water use in biofuels, or only technologies to reduce energy use in water treatment. For example, past research roadmaps conducted by the Department of Energy (DOE), Department of Agriculture, and the department of the Interior (DOI) have not looked at the breadth of technical, social, policy, and economic issues and concerns that impact the nexus of energy and water.

Technical innovations for sustainable energy and water management are occurring at all levels of society. For some energy-lean water technologies and water-lean energy technologies, the primary limitation is technical and the workshop was used to help identify technologies that show the most promise and research needs to realize that promise. Other limitations might include regulatory barriers, cultural inhibitions, or ill-designed market frameworks. In those cases, the limitations for market adoption are not because of technical limitations, but rather are the result of poor understanding or unintended incentives and disincentives. In those cases, communication and strategies need to be improved, which as the final topic of the workshop.

This workshop was used to identify a comprehensive set of research needs that cut across many topical areas, professional disciplines, and relevant government agencies. That comprehensive list is presented here in synthesized and organized form. The summarized and prioritized research needs are noted in Section 4. The research opportunities for each of the four sessions are organized into technical, social and policy categories.

### Research Needs I: Water for Power Production

This session of the workshop identified different needs that could fit into a broader program of research at the energy water nexus with a focus on water for power production.

#### Technical

1. *Better data*: Because the existing available data for water are inaccurate, limited in resolution, and outdated, they inhibit the ability to accurately model, predict and manage resources. Thus, there is a significant need for better data and better sharing of those datasets. The following characteristics are important to consider for improved data collection technologies and sharing tools:

- a. Shared data sets should be
    - i. Validated
    - ii. Reported with consistent naming conventions, boundaries, and parameters
    - iii. Available via a robust, user-friendly public water data portal:
      - 1. Compilation of existing energy-water data from various studies
      - 2. Leveraging energy-water raw data collected in the five regional workshops
  - b. A framework for the data is necessary so that they can be incorporated (with effective assumptions) for decision support tools under uncertainty
  - c. Specific data elements that are needed for strategic planning, modeling, and analysis:
    - i. National water usage
    - ii. National water quality
    - iii. Evaporation downstream of open cooling plants not included in EIA collected data
    - iv. Intersection with other sectors
  - d. Real-time data collection: in addition to monthly or annual averages, development of sensors for in-situ and real-time data collection would be very valuable
  - e. Better inventories of evaporation
    - i. Water use (and lost) from pumped hydropower
    - ii. Evaluate consumption downstream power plant from increased water temperatures that are not considered in reporting of consumption
    - iii. Environmental impacts of once through cooling and evaporation in ponds
    - iv. Reduce water impact of carbon capture
  - f. Impact of carbon emissions needs to be considered with water assessment when comparing technologies
    - i. Conduct another set of regional workshops, data collection
    - ii. Focus on selling results to Congress
2. *Decision Support Tools*: Modeling and planning tools that integrate datasets to help guide asset and operational decisions are sorely needed. These support tools need effective analytical frameworks, significant data inputs, and multi-resource, multi-scale (temporal and spatial), and multi-user capabilities.
  3. *Reducing waste and improving efficiency*: There are several technologies that can be pursued for improving operational efficiency at power plants.
    - a. Waste heat capture technology research (there is significant waste heat at power plants)
    - b. Better pump design for reducing parasitic load of water circulation systems.
  4. *Cooling Systems that Require Less water*:
    - a. Passive cooling: Research natural technologies (bio mimicry) to decrease water needs for cooling (example: water cooling by reforestation upstream that provides shade)
    - b. Dry cooling

- i. Better heat exchanger designs and high surface area coatings for more effective heat transfer.
    - ii. Advanced air cooling technologies (novel thermodynamic cycles, etc.).
  - c. Hybrid cooling
  - d. Better heat exchanger designs
  - e.
- 5. Holistic life cycle analysis with policy flexibility to enable site specific and watershed specific decision-making that considers emissions and water together
  - a. Model needs to be applicable to all systems but structure is flexible enough to accommodate range of ecosystems under uncertainty of pricing in water, energy, and carbon
  - b. Need to know projections of pricing and regulations
    - i. Water use (and lost) from pumped hydropower
    - ii. Evaluate consumption downstream power plant from increased water temperatures that are not considered in reporting of consumption
    - iii. Environmental impacts of once through cooling and evaporation in ponds
    - iv. Reduce water impact of carbon capture
- 6. *Integrated Modeling and Planning*: Should have a more integrated approach that includes water, energy, food, security, environmental sectors/stakeholders.
  - a. Water is still mainly for used for agriculture around the world and this use is also causing environmental issues.
  - b. Trade-off management - If not managed well we will have issues with social equity between different sectors – water, energy, food, environment.
- 7. We have to foster a paradigm for a sustainable water use for power generation.
  - a. Need metrics of sustainability.
  - b. Energy/water/climate trifecta. Given potential climate change issues, we should determine future water requirements for use and energy production, and predict if we will have enough water to support our future needs.
    - i. Biggest challenge with climate is we don't know what will happen but we need to include it in the discussion.
- 8. Distributed generation – combined heat/power which is more viable at a smaller scale.
- 9. Looking at technologies for air pollution/quality control
  - a. We are changing fuels to reduce emissions but maybe look at new technologies to improve emissions and not change fuels?
  - b. Perhaps there is a disconnect from a policy standpoint on using a renewable energy source and understanding the water intensity of it.
    - i. This is true for all energy generation not limited to renewable energy.
  - c. Water and energy impact of carbon capture
    - i. Technologies have major energy and water penalties associated with them
    - ii. Not regional in nature
    - iii. 85% increase in water requirements
    - iv. Could increase with the implementation of a carbon tax
- 10. Reclaimed water

- a. Supply availability
    - i. Daily, seasonal, technological changes effect quantity and ability to supply the same amount
  - b. Upfront capital cost
    - i. Piping, signage, etc...
    - ii. Palo Verde – 60 mile pipeline
  - c. Competing uses for effluent
    - i. Not enough availability in certain areas
    - ii. Ex: Texas using effluent for drinking water
    - iii. Ex: Baseflow in Michigan consists almost entirely of municipal effluent
    - iv. Possible security concerns of piping to nuclear facilities.
11. How open is the power sector to innovation?
- a. Co-location of energy and water facilities
  - b. Technical and economic approaches
  - c. Centralized, decentralized facilities
12. Pump storage or dams of water for electricity generation and demand management, water control
13. Lifecycle assessment
- a. Ex: biofuels assessment (“even down to the fertilizer”)
  - b. Include all energy options for regional planning
  - c. Include economics, resource demand, social aspects
  - d. Compare options in both short and long-term with standardized metrics
  - e. Upstream and downstream costs and resources
  - f. Energy and water development decisions
  - g. Co-location
  - h. Long-term, consistent projects
  - i. Consistent funding
  - j. New technologies
  - k. Low cost, low water use, low emissions, low waste
  - l. Limit the trade-off when implementing a technology
  - m. Better utilization beyond research
14. Energy production from wastewater treatment plants
- a. Focused dialogue between power and waste industries to integrate energy production onto the grid
  - b. BTU value of wastewater going into treatment plant is 5x that needed to treat the wastewater
  - c. Could fit into disaster response if wastewater plant is off-grid
  - d. Include choice of location and method of processing wastewater
  - e. Include mineral capture
15. How do we prepare for drought, extreme situations ahead of time?
16. Smart technologies
- a. Big data on large scale
  - b. Real-time data on small scale
  - c. Sensors
  - d. Preventative maintenance of the system
  - e. Communication



17. Prioritize funding for important research needs
  - a. To take technologies beyond peer reviewed journals
18. More joint research efforts
  - a. Cross government
  - b. Government/Industry
19. Potential for use of direct current instead of alternating current

## Social

1. Education, Communication: Public knowledge of water issues and water energy nexus
  - a. Funding to universities to provide workshops and curriculum
  - b. Increase funding to integrated grants that require educational components
  - c. Outreach to media
  - d. Cross section of institutions, partnerships organized by unbiased source (NSF)
  - e. Need for training next generation of utility operators
    - i. K-12
    - ii. What are the new skills they will need to know?
  - f. Get people to care before a crisis
    - ii. Understanding the appropriate amount of communication and education to the public.
    - iii. Talk about potential disasters (like hurricanes, droughts, etc) that can happen in YOUR region so it “hits home.”
    - iv. How do you communicate water issues when we are NOT in a drought? It’s hard to get people to care when it isn’t an immediate threat.
    - v. How can you “recreate” the crisis that occurred so that you keep momentum going to help support policy change and other changes. Because often there are missed opportunities because people’s interest wanes.
  - b. Scenario based communication tools for the stakeholder and water users.
  - c. How do you communicate water and energy implications when you have economic growth and population growth in communities?
    1. We need an index to understand how growth affects water and energy. How to show/communicate to public.
    2. “Water sustainability index”
    3. We assume we can move anywhere in this country and we’ll have water and energy but this might change soon.
  - d. Public perception, knowledge
    - i. Can inhibit development of new technologies, solutions
    - ii. Easy for misinformation to be generated on the internet
    - iii. Minority of people that understand implications of water and energy integration
      1. TVA: vocal minority

2. Allocation of water
  - a. Address deeply entrenched issue of moving water and water rights
  - b. Understanding of how communities accept and respond to water issues
  - c. Consider different systems of rights for better allocation
  - d. Taking other water users into account
    - i. Competing demands for water, ex: agriculture
    - ii. Communication, integrated planning between different water users
      1. Planning often based on who has money and not on who uses water
3. Water Markets
  - a. Privatizing Water – look at different economic models. How do you get to privatize water markets?
  - b. Impact of pricing
    - i. Recently: low natural gas prices phasing out coal
    - ii. Costs of infrastructure
4. Look to nations that are further down the crisis curve and ask ourselves what we are learning from them that can help us adjust our models in our nation.
  - a. Example: In Australia, the water issues became so painful that it triggered major policy changes.
    1. How do you avoid message fatigue?
  - b. Research Question: is public perception important if we are trying to looking at barriers or reason what are the pathways to decrease the electricity
  - c. Identifying **road blocks in water use and conservation.**
5. Moving research to implementation:
  - a. What are the barriers that make it hard for new technologies in energy and water to make the leap across the “valley of death” from research to being implemented/market place. This seems to be particularly bad for water and energy.
  - b. Identifying cross sector gaps in water resourcing and applying technology solutions to fill them.
    - i. For example water treatment technologies being developed for fracking but maybe that could be used to some extent in agriculture or other industries.
6. Water footprint
  - a. Water footprint of interbasin transfer:
    - i. Using water in one place and using the product (power) in another place
7. Looking at the future
  - a. Current problems in the existing fleet might be different than future problems
8. Dispatching
  - a. Power dispatch does not look at water usage
  - b. Based on resources
  - c. Based on region
  - d. Who pays? Does the power utility pay for water conservation? Do customers? How does that effect the customer base (including the poor)?

9. Energy, water conservation
  - a. The market does not incentivize conservation of water
  - b. Maintenance
  - c. Usage
  - d. Water security value of energy efficiency
  - e. Energy security value of water efficiency
  - f. Smart technologies
  - g. Raising public awareness in their role in water and energy supplies
    - i. Positive motivation: Not a tone of fear, but a tone of progress

## Policy

1. Need for shared standard of definitions and metrics for reporting and evaluating tradeoffs
  - a. Framework on how to weight ecological impacts versus water consumption
  - b. Funding stream for consistency and validation of data collection
    - i. Validation needs to come from users of data
    - ii. Examples: total dissolved solids, report for peak use or average use, report for drought or average conditions, “use” as withdrawal or consumption, categorize closed versus open by size of cooling reservoir
  - c. There should be water consumption standards so that all power plants report using the same terminology and understanding. That is, guidelines are needed so we can compare plants from east to west, north to south.
  - d.
2. Valuation of water
  - a. Financial model should consider projections (and uncertainty of projections) of prices, availability, and other conditions
  - b. Energy is much easier to value than water.
  - c. What is the true cost of water?
  - d. What is the true value of water?
  - e. Need point of use/valuation metrics.
  - f. Should be looked at regionally
  - g. Example: if we knew the true cost and value of water, we might think more critically about what crops we grow in different regions.
  - h. How does the electricity sector play into the water markets?
3. Planning process that considers technology, social, and policy implications together
  - a. Siting of plants
  - b. Integrated resource planning
  - c. Water impacts need to be integrated in investment decision
  - d. Waste energy
  - e. Examine current policy and identify incentives and barriers of energy-water nexus goals
  - f. Remove barriers at local, state, and federal level
  - g. Recognize competing interests: local versus national, ecological versus financial

- h. National policy lacks flexibility that allows for regional specific benefits
- i. Address issue of lack of revenue to utilities by distributed energy generation that benefits water issues
  - i. Distributed energy generation can undermine long term revenue models of utilities
- 4. National Water Policy
  - a. We don't have an overall water policy for the nation. Maybe we should have a national water policy?
    - i. Creates regulatory uncertainty
    - ii. What would a national water policy look like?
    - iii. How do you mesh a national energy policy together with state water policy?
    - iv. Maybe we could encourage (through policy) building power plants where there is available water.
    - v. Water is currently being managed by a lot of departments.
    - vi. Collaboration and communication with other government agencies working on water issues.
    - vii. Water has some antiquated policies for example water amounts allotted to different sectors (agriculture, industry, & municipal) is sometimes done rather arbitrarily (allotted a specific percentage of water).
      - 1. One idea is to "sunset" some of these outdated policies & restrictions.
    - viii. 316b challenges in cooling for power plants on the coast
      - 1. Regulates, but does not eliminate the use of open loop cooling for seawater
  - b. Regional collaboration
    - i. Currently differing regional water resource management approaches
    - ii. Integrated water-energy planning and modeling on a regional, watershed scale
  - c. Coordination between agencies at the federal level to facilitate water-energy planning
    - i. Existing: Federal Advisory Committee on Water Information (ACWI)
      - 1. Headed by Department of Interior
      - 2. Members: USDA, EPA, state and community organizations, industry
      - 3. Discuss integration of databases, groundwater research and survey programs, ask for feedback on EPA programs
      - 4. Potential for more DOE participation
    - ii. Complicated by states' water laws
    - iii. Coordination between DOE and NSF energy-water roadmaps
- 5. Infrastructure
  - a. Smart water grids and infrastructure can help solve some of these problems
    - i. What are the barriers to do this?
- 6. Risk Assessment

- a. look across the issues and prioritize to figure out where to focus our efforts and where to make investments
  - b. Use modeling and data as input and determine an assessment framework.
- 7. The US government spends ~\$1 billion/year on water related issues and we need to obtain information to better understand what that money is spent on. What (if any) research is it supporting?
- 8. National security
- 9. What are the institutional barriers to more efficient water use?
- 10. What are the institutional barriers to choose one direction vs. another (e.g. improve technologies vs. keeping prices down)?
- 11. How do you coordinate perspective, planning differences between energy and water planners?
  - a. Energy planners thinking short-term
    - i. Beholden to rate payers
    - ii. Shorter construction time-frame:
      - 1. TVA rep, Michael McCall: Gas plants can be built in 3-4 years
      - 2. Combined cycle 5 years
      - 3. Difference in time-frame for regulated and de-regulated power markets
    - iii. Given a demand and finding, allocating supply
  - b. Water planners thinking long-term
    - i. Wastewater treatment plant could take 7-10 years including getting permits
    - ii. Given a supply and allocating based on demand
- 12. Hydro power
  - a. Environmental regulation
  - b. Climate
    - i. Timing and management of releases on the river is changing
      - 1. Releasing for environment, recreation, power, flood control?
  - c. How do we dispatch it with regard to the entire energy portfolio?

## Research Needs II: Water for Fuels Production

### Technical

- 1) Hydraulic fracturing
  - a. Need for reuse, or general use, of water from fracking
    - i. Present: proprietary, predominantly hidden by companies
    - ii. Future: need to develop new technologies and approaches
      - 1. Example: green chemistry, green completion
    - iii. Need to understand the characteristics of flowback/produced water
  - b. Treatment, reuse of waste
    - i. Retrofitting wastewater treatment plants so they can take fracking effluent water.
    - ii. Distributed, on-site treatment

1. High volume, low energy use, cost-efficient
2. Has to be able to deal with different variations in waste stream chemistry
- iii. Use natural gas to desalinate the water on site
- iv. How to deal with the waste stream post-treatment? (concentrate disposal)
- v. Real-time analytics and sensors for treatment controls
- vi. Treatment systems for saline water. There are no conventional treatment technologies for high salinity water.
- vii. Dewater solids to send to landfills instead of injection well
  1. less trucking of water
- viii. Beneficial use of “waste” from produced waters
- c. Waterless fracking
  - i. What is the tradeoff between using more chemicals and less water?
  - ii. More chemicals vs. More water consumed
- d. Source water switch
  - i. Where (and when) can you switch from freshwater to brackish water use?
  - ii. Need a better understanding of water availability by type (fresh, brackish, etc.)
    1. Need to properly define saline, fresh, etc.
- e. How much produced water will you get based on different parameters?
- f. Conduct a study to see what would be more environmentally sound, and economically advantageous between disposal or reuse of wastewater
- 2) Water and groundwater quality
  - a. Fingerprinting: examining groundwater
  - b. Background: the status before and after O&G development
- 3) Sensors and monitoring
  - a. Methane sensors for detecting leaks into atmosphere
  - b. Downhole sensors
  - c. Strategic sensors
  - d. Advanced sensors: Real-time data to measure, predict, determine, mitigate accidents
  - e. Data on accidents/disasters occurring in the type of machinery associated
- 4) Biofuels
  - a. Coupling algae and biofuel
    - i. How would we use algae to clean up wastewater?
  - b. Formulating a productive comparison tool for freshwater and not freshwater source
  - c. Examine biofuel that might improve the quality of our soil
  - d. Decision tool for value of biofuels
  - e. NSF needs to look at second-generation biofuels and really assess them
- 5) Fuels
  - a. Storage and conversion of alternate fuels to make them useful (biogas, natural gas that is flared, etc.)

- b. We should look at using the abundant natural gas resource in the US for more applications
  - c. More storage options so as to curtail flaring
  - d. Biogas from wastewater treatment facilities
- 6) Solar water desalination
- a. Water desalination and hydrogen projection
  - b. CSP for desalination (solar heat more efficient)
  - c. Lots of small-scale work dealing with solar water desalination
    - i. Energy-intensive solar PV (10-20 years in the future) with thermal storage
  - d. So many alternatives, which one to use: CSP, reverse osmosis, distillation directly?
    - i. Approaching an entirely new process – membrane-distillation, desalination
    - ii. Cogeneration, CHP – energy cost vs. current technology
    - iii. Thermodynamic assessment of cost for treating water irrespective of treatment method
    - iv. Temperature tolerant technology research
  - e. Materials innovation, component level innovation for treatment technology
- 7) Other ideas
- a. New water harvesting techniques
  - b. Better water modeling tools, more integrated multi-resource tools that do not exist today, better planners, these platforms would be useful
  - c. Distributed water source, achieving small-scale deficiencies

## Social

- 1) Communication
  - a. Communication strategy with forums
  - b. Dispersion of information about accident
  - c. Understanding how to communicate effectively when we are “certain” or “not certain” support collaboration
- 2) Competition for resources
  - a. Is water best used by agriculture or by energy sector?
- 3) Mitigate excessive water trucking
- 4) Creating more viable entry and exit points for Boomtowns. Change in cities when oil and gas companies come
- 5) Water acceptance for reuse, security
- 6) Business models that would be sustainable for multiple users
- 7) Water and energy market collaboration

## Policy

- 1) Zipcode based search for policy that is similar to water data (similar to hydrologic IDs)
- 2) Policy frameworks: energy/water

- a) National, state/regional, local
- 3) Policies to allow marketing for recycled water
- 4) Regional differences and regulations
- 5) Water rights issues. Who owns the water?
- 6) How do we create flexibility in policies over time?
- 7) Are there technologies that can help with some of the social issues?
  - a) Especially in response to economic changes
- 8) Re-examining the assessment framework of technologies
  - a) Matrix used for assessment in the waiting factors
  - b) Lifecycle analysis of greenhouse gas emissions
- 9) Public health study of the water quality
- 10) Reallocation of water among sectors: time of use pricing, shift the energy use, off-peak water
  - a) Treat water? Transport water? How will the efficiency and future change?
- 11) Business model innovation or marketing restructuring?
  - a) What should new business models look like?
    - i) Comparison with other countries
    - ii) Case studies
    - iii) Might be a tech-enabled or policy-enabled business model
- 12) Research question: what are the regulatory regimes for saline/brackish water?
- 13) Rigid, antiquated regulations with respect to produce water
  - a) Currently cannot discharge treated produced water that is thermally distill to pure water just because it started as produced water

### Research Needs III: Energy for Water

Facilitators: Kelly Sanders (UT/USC), Ned Spang (UC Davis), Drue Whittecar (National Oilwell VARCO)

Rapporteurs: Mary Clayton, Roxana Darvari, Bonnie Roberts, Lily Xu

1. Better membrane
2. More efficient Pumps
3. Integrated Heat Exchange
4. SMART Technology
5. Grey Water (Reclaim & Reuse)
6. Source Switching (Effluent & Brackish)
7. Integrated Rooftop Reclaim Systems
8. Continual Systems (Renewable)
9. Tool Kits
10. Extra Topics:
  - a. Microbial fuel cells
  - b. Electrochemical fractional
  - c. Photo catalytic



## Technical

1. Heat scavengers
  - a. How can we utilize this extra heat from the heat scavengers? Perhaps to treat water or power some steam? How can we capture this excess heat?
  - b. How can we cogenerate power and clean water?
  - c. How can we use excess heat from the fuel cell to reduce the energy requirement for the water purification?
2. Retrofitting infrastructure
  - a. How can we be more clever in terms of what types of retrofitting technology we need? Best techniques?
  - b. How can we utilize existing and new technologies smartly?
  - c. Adaptable infrastructure that can adopt new technologies with simple retrofits
3. National incubator or certification program
  - a. Are we in a need for an applied research lab? Would a product acceleration/commercialization lab give all these start-ups a good incubation platform?
  - b. Should we filter and facilitate technologies?
4. Decentralized versus centralized system
  - a. Which is more efficient? A tool for deciding under what conditions is one system best
  - b. Quantify gaps in costs between systems.
  - c. Must consider social externalities.
  - d. Assess where a microgrid concept would be applicable
  - e. Determine security challenges and vulnerabilities in each
  - f. How to capture resources currently being wasted with centralized that could be captured with a decentralized system. For example, some are currently flaring gasses because it's not worth building infrastructure to distribute.
5. Define the water toolbox
  - a. Who houses it?
  - b. Ensure no bias
  - c. Collaborative effort
  - d. Model of quantity of different sources of available water
6. Fill technology gaps
  - a. Concentrates: finding a process that deals with finding concentrates more effectively
  - b. Concentrate management methods with demonstration of low environmental impact
  - c. Membranes: dealing with high energy cost
  - d. More efficient pumps
    - i. How do we increase pump efficiency? (More than simply increasing mechanical design)

- ii. Friction reducers
- e. Better energy and water storage systems
- f. Controls+SCADA for water loss in plants (monitoring and analysis)
- g. Look at matching natural energy resources for the region to the methods for water treatment.
- 7. Source-switching
  - a. How do we treat brackish aquifers? How do we build in a capability of leveraging these as a source? What will the impacts be in terms of recharge?
  - b. Match water quality to use
- 8. Real-time analytics: better sensors
  - a. Better gage sizing of streams
  - b. Groundwater sensing networks – better monitoring and access
    - i. Model and predict groundwater availability and expected and project use.
    - ii. How can we better utilize this projected use for rural or urban use?
- 9. SMART agriculture technology
  - a. Applying existing technology to agricultural use
  - b. How do we reduce agricultural impact on everything else?
  - c. Need additional source since conservation can only take us so far
- 10. More advanced integrated home and water system – septic field
  - a. Distributed water-wastewater treatment on site
  - b. How can we improve urban building design?
  - c. Onsite capture and treatment of storm and grey water
- 11. Cyber Security
  - a. What is needed in addition to traditional security?
  - b. Consider tradeoffs of centralized and distributed

## Social

- 1. Security & stability of a distributed grid
  - a. Cyber security problem – extreme weather situations that may impact the grid
  - b. Changes in regulations needed to enable more distributed systems: Regulations have grown around large treatment plants
- 2. Communication:
  - a. Need a better translation for policy regulators or public utilities (to justify expenditure)
  - b. Need designated industry people who can connect the engineers to the policy regulators. (Drue)
  - c. Better translation of science to decision makers.
- 3. Private-public partnerships for funding
  - a. Begin implementation at community or basin scale
  - b. Fund DDD in addition to basic research
  - c. Technical societies

4. Gaining regulatory variability for water and energy as they overlap with uses to shape policy and funding
  - a. Better coordination between legislation and regulation
  - b. Leg
5. Water reuse
  - a. Identify and remove barriers that prevent gray water use
  - b. Consider delivery systems such as underground sprinklers
  - c. Research need: Public health obstacles to reuse
  - d. Create one flexible centralized plan that enables distributed reuse
6. Look at water facilities as potential energy storage and then use for peak demand.
7. Water markets
8. Integrated permitting:
  - ✓ Reduce conflicting
  - ✓ Streamline
  - ✓ Enable system approach
  - ✓ CEC licensing model for power plants
  - ✓ Sufficient authority for integrated framework

## Policy

1. Professional organizations
  - a. The problem: perhaps too many professional water organizations with overlapping speakers
  - b. We should try to utilize professional organizations to address more social/policy issues, disseminate to the right people collaborate more
  - c. Minimize competition, conflicting presence and focus on collaboration
  - d. Professional societies need to reach out to municipalities, etc. and educate the public.
2. Collaboration vs. Competition
  - a. Organize collaborative messaging to avoid conflicting messages (ex. Two agencies API and EPA may be in a race with conflicting agendas)
    - i. Coverage is of utmost importance – power in numbers.
    - ii. How do we get over the antagonistic hump between industry and regulators? What is the role society can play?
3. Education
  - a. Need education program for the general public
    - i. True cost
    - ii. Competing resources
    - iii. Gain acceptance of reuse and reclaim water
    - iv. Use success stories (Orange county, Singapore) – sophisticated
    - v. Address resistance to building large scale desalination plants
    - vi. Messaging is huge, simple “motto”
    - vii. Underfunded infrastructure
    - viii. Water rate schemes
  - b. A virtual education course for professionals

- i. There is currently a lot of disconnect
  - c. Virtual university
- 4. Cost versus price versus value of water (perception)
  - a. Equity issues
  - b. Education about water valuation
  - c. Valuing externalities (positive or negative)
- 5. Mechanism of revolving funds. Helpful for long term projects and valuing resources.

## Research Needs IV: Communications, Social and Behavior

Facilitators: Michael Allen, Mary Beth Maddox and Cherie Rachel

Rapporteurs: Margaret Cook, Jill Kjellsson and Bonnie Roberts

- Cross cut:
  - Smart grid
  - Smart water
  - Smart sensing

## Technical

- Data gathering and collaboration
  - \*\*Best practices in industry worldwide
    - This product (without company names) is good
      - Ex: Case study on variable frequency drives
    - Breakdown success stories into research projects
      - How did the research evolve?
      - How was it funded?
      - Use studies to identify tools for replication in other environments
    - \*\*Reasonable performance metric, standard, templates, protocols, guidelines
      - People can make decisions on what standards should be
      - Diverse group as a source of information
      - Use pilot studies
    - Could be done by industry groups
      - Could be collaboration between NSF, research groups and industry groups
  - Commercialization of ideas
    - Show cost-effectiveness
      - Bottom line, translates effectively
    - No incentive for academia to go beyond publication
    - Collaboration with someone who can represent/produce material
  - \*\*Survey plants to determine energy-water nexus needs

- Inform research
- Develop a database of plants that would like to participate in research projects
- Categorize cost-share mechanisms
- Could be done by industry groups
  - Could be collaboration between NSF, research groups and industry groups
- \*\*Use NSF/EPRI collaboration as a model for other collaboration efforts
  - Cost-match, synergy
  - Sensitivities, privacy

## Social

- Education and communication
  - Could NSF pull together education workshops, webinars, lectures to help professional societies communicate to diverse audiences?
  - Magazine to address recent topics without delay that typical publications have
    - Audiences addressed
    - “pop science”
    - Graphics/descriptions
  - NSF require 1-3 page overview for every project, plain language (laymans publication as part of project funded by NSF)
  - Develop tools/approaches that work for communication
  - Educate professional societies?
    - Study the ways/effectiveness of professional society communications
  - \*\*Professional society courses on Energy-Water Nexus sub-discipline within universities
  - \*\*Develop Energy-Water Nexus 101 Curriculum for different levels
    - Curriculum for K-12
      - Difficulty with getting curriculum approved at varying levels
        - Keep the different audiences in mind: K-12, teachers, administrators at department of education or state education boards
    - Those currently in the field
    - Those entering field
  - Conferences
    - Network
    - More coordination between societies
    - Scale up
      - Conferences
      - Then workshops
      - Lastly forums (closed note, more free to talk)
    - Industry only can afford to send to so many, so need to combine/unite
    - Joint session

- Cater to groups that are really involved (Journal of desalination- so all people interested in desalination can go to one place)
  - Need world view
- Educate the general public
  - Use of grey water
  - Use of bottled water
- TEDtalks
- Keywords for ease of finding information/articles
  - “nexus”, “carbon capture”
- \*\*Research idea: Meta study of collaborative NGO/Industry partnerships
  - Identify drivers to success
- Use media, social media to communicate with general public
  - Not just through professional societies
  - Come to people using same way people speak to each other
  - Tap into coming interest
    - Ex: Ad council working with Water Environment Federation
- Pop culture
  - Movies, TV, books
  - Technical illustrations, podcasts, videos
    - Ex: National geographic (pictures? - how they pick from thousands? how pick effective ones?)
      - Takes lots of money, we need to put money towards this
- Collaboration between science, engineering, advocacy, business groups
  - Ex: Carbon Management (AIChE, ASME, ASCE, IEEE, etc)
  - Pull stakeholders together
    - Through dual memberships
    - Through NSF workshop such as this
  - Include advocacy branches of professional societies
  - Include electro-chemical society
    - Membrane separation/deionization
  - \*\*Include business and industry groups
    - Chambers of commerce
    - Be aware of differing terminologies
      - Will not know differences until actually engaging different groups
    - Ex: Texas industry groups, H2O4Texas
  - Roundtable with various types of groups (including research and regulators)
    - Communication tool- how to get everyone on the same page, aligned long-term
    - How to align economic, regulatory, and incentive programs with resource management policies/programs
    - \*\*Energy-water and business - planning/architecture
      - Because building codes/regulations inform the process
      - Make sure thinking is aligned

- Audience is important
  - Before general public, need to make sure regulators/people inside now first
  - Time, effort and money
    - To get to some people who don't have the above (including state regulators)
    - Look to groups that do bring these people in
      - For example GWPC, EPA model (council) – but run by regulators
      - ITRC
  
- **\*\*Societal behavior**
  - Personal decisions (social, behavioral issue) we make about how we use water, energy
  - Conservation behavior
    - Avoided water
  - Hard research objectives:
    - How society has come to value resources the way that we do?
    - Behavioral aspect of decision making
    - How did water rights form
    - Give insight into how we can change that mindset, influence those decisions now to make resources more sustainable?
  
- Need for unbiased source of information
  - Bring parties together
  - To share information
  - Not to take a side
    - Societies (for policy and Capitol Hill, but not for public)
  - Need for toolkit development
    - Exxon (Energy for Me)
  - Scale of outreach and engagement
    - National
    - State
    - Local/ community level engagement (ie for conservation)
  - Issue and audience-based messaging
  - Identifying experts and bringing them to table
  - Good communicators
  
- Identify purpose
  - Disseminate information
  - Professional groups
  - Gather funding for more work
  
- What should not be done:

- Have sub-groups dictate what research will and will not focus on
- Peer reviewed journals (too long, group that will read those journals are not ones that want to reach)
- Don't lobby
- Don't be quiet about issue (promote)
- Lobby issue not position

## Policy

- \*\*Review of state policies/regulations
  - Similar to Alliance for Water Efficiency work done recently
  - Review policies that aid or inhibit the water-energy nexus



## Appendix B: Workshop Participants

Role	Name	Last	Institution
	Amy	Abel	Congressional Research Service
Facilitator	Michael	Allen	ExxonMobil
	Sam	Baldwin	Department of Energy
	Philippe	Bardet	George Washington University
	Diana	Bauer	Department of Energy
	Vatsal	Bhatt	Brookhaven National Laboratory
	Samuel	Biondo	Department of Energy
	Ernest	Blatchley	Purdue University
	Michael	Bowen	Department of Homeland Security
	Lynn	Broadus	Johnson Foundation
	Rick	Buckley	Entergy
Facilitator	Joel	Burken	Missouri University of Science and Technology
	Sean	Bushart	EPRI
Speaker	Ximing	Cai	University of Illinois at Urbana-Champaign
	Caitlin	Callaghan	Department of Energy
	Adam	Carpenter	American Water Works Association
	William	Carrigg	US Government Accountability Office
	Tom	Carter	Johnson Controls
	Joe	Casola	Center for Climate and Energy Solutions
	Daniel	Cassidy	US Department of Agriculture
	Nirmal	Chaudhary	US Government Accountability Office
Facilitator	Shahid	Chaudhry	California Energy Commission
	Naveen	Chennubhotla	Marathon Oil
	Roger	Claff	American Petroleum institute
Rapporteur	Mary	Clayton	The University of Texas at Austin
Speaker	Yoram	Cohen	UCLA
Rapporteur	Margaret	Cook	The University of Texas at Austin
	Eric	Cutter	Energy and Environmental Economics
Rapporteur	Roxana	Darvari	The University of Texas at Austin
	Gordon	Day	IEEE
	Vlad	Dorjets	Energy Information Administration
	Paul	Faeth	Center for Naval Analysis
	Cha Chi	Fan	Energy Information Administration
	James	Ferro	Energy Coalition
	Evan	Flach	AICHE
	Russell	Furnari	PSEG

	John	Gasper	Argonne National Laboratory
	Jan	Gilbreath	Environmental Protection Agency
Rapporteur	Yael	Glazer	The University of Texas at Austin
Speaker	Robert	Goldstein	EPRI
	Bruce	Hamilton	National Science Foundation
	Cyd	Hamilton	Department of Energy
	Christopher	Harto	Argonne National Laboratory
	Marilu	Hastings	Mitchell Foundation
Speaker	Mike	Hightower	Sandia National Laboratory
	Patrick	Holman	Department of Energy
	Tissa	Illangasekare	Colorado School of Mines
	Jeni	Keisman	Department of Energy
Rapporteur	Jill	Kjellsson	The University of Texas at Austin
	Marc	Kodack	U.S. Army
	Yusuke	Kuwayama	Resources for the Future
	Elisabetta	Lambertini	
	Kevin	Lansey	The University of Arizona
	Russell	Lefevre	IEEE
	Jennifer	Li	Department of Energy
	Maike	Luiken	IEEE
	Maike	Luiken	Lambton College
	Robert	Lung	Alliance to Save Energy
	Tengfei	Luo	University of Notre Dame
	Brian	Lutz	Kent State University
	Andrew	Maddocks	
Facilitator	Mary Beth	Maddox	The University of Texas at Austin
	Robin	Madel	Grace Communities Foundation
	Matthew	Mantell	Chesapeake Energy
	Barbara	Martinez	Environmental Protection Agency
	Arash	Massoudieh	The Catholic University of America
	Enrique	Matheu	Department of Homeland Security
	Michael	Mccall	Tennessee Valley Authority
	Glenn	McGrath	Energy Information Administration
	Trey	Mebane	National Oilwell Varco
Speaker	Roland	Moreau	ExxonMobil
	Daniel	Morris	Resources for the Future
	Marina	Moses	National Academy of Sciences
	Sundar	Narayanan	ExxonMobil
	Hashem	Nehrir	Montana State University
	George	Nnanna	Purdue University
	Kathleen	O'Connor	NYSERDA

	Sheila	Olmstead	Resources for the Future
	Shawn	O'Neill	Fairfax Water
	Brian	Parsons	ASCE
	Hatef	Pazhand	George Washington University
	Janet	Peace	Center for Climate and Energy Solutions
	Donna	Perla	Environmental Protection Agency
	Mark	Philbrick	Department of Energy
	Charles	Podolak	Duke University
	Jim	Powell	AWMA
	Shaurya	Prakash	Ohio State University
	Theresa	Pugh	American Public Power Association
Facilitator	Cherie	Rachel	The University of Texas at Austin
Speaker	Danny	Reible	Texas Tech University
	Debbie	Reinhart	National Science Foundation
Rapporteur	Bonnie	Roberts	The University of Texas at Austin
	John	Rogers	Union of Concerned Scientists
Facilitator	Kelly	Sanders	University of Southern California
Speaker	Darlene	Schuster	AICHE
	Les	Shephard	UT San Antonio
	Jessica	Shi	EPRI
	Susan	Shifflett	Woodrow Wilson Center
	Cat	Shrier	Water Citizen News
	Paul	Shriner	Environmental Protection Agency
	Danmeng	Shuai	University of Iowa
	William	Skaff	Nuclear Energy Institute
	Ethan T.	Smith	
	Brandy	Smith	ASME
Facilitator	Ned	Spang	UC David
	Ashlynn	Stillwell	University of Illinois at Urbana-Champaign
	Jennifer	Stone	Strategic Operational Solutions, Inc
Facilitator	Amul	Tevar	ARPA-E
	Vincent	Tidwell	Sandia National Laboratory
Facilitator	Dr. Michael	Tinkleman	ASME
	Kirtan	Trivedi	ExxonMobil
	Cynthia	Truelove	Stanford University
	Sara	Tucker	Senate Energy and Natural Resources Committee
	Jennifer	Turner	Woodrow Wilson Center
	Venki	Uddameri	Texas Tech University
Rapporteur	Charles	Upshaw	The University of Texas at Austin
	Eric	Wachsman	University of Maryland Energy Research Center

Speaker	Michael	Webber	The University of Texas at Austin
	Brittany	Westlake	Department of Energy
Speaker	Lorraine	White	GEI Consultants
Facilitator	Drue Ann	Whittecar	National Oilwell Varco
	Robert	Wilkinson	UC Santa Barbara
	Jim	Williams	Energy and Environmental Economics
Rapporteur	Lily	Xu	The University of Texas at Austin
	Craig	Zamuda	Department of Energy
	Kendra	Zamzow	Environmental Protection Agency
	Qiong	Zhang	University of South Florida

## **Appendix C: Workshop Presentations**

The workshop presentations are included here.

# NSF WORKSHOP ON THE ENERGY WATER NEXUS

Mike Hightower, Danny Reible, Michael Webber

Organizers

June 10-11, 2013

Washington, DC

# Workshop on the Energy Water Nexus

- ▣ What are the most critical challenges, needs and opportunities associated with the relationship of energy and water?
- ▣ What are the cross-sector dependencies that introduce vulnerabilities to critical infrastructure?
- ▣ What critical resources research can support cross-cutting solutions that improve the relationship for both sectors simultaneously?

# Goals of the Workshop

- ▣ Generate a research roadmap,
  - What are the technical, social and policy barriers?
  - Where is the state of the science today?
  - Where we want to go as a society?
  - What is the technical/social/policy roadmap to get from here to there?
- ▣ Start to build a community of capabilities to address that research roadmap



# Workshop Themes

- ▣ “Water for Power”
  - Managing water demand for the production of power
- ▣ “Water for Fuels”
  - Managing water demand for the production of fuels
    - ▣ Water for Biofuels
    - ▣ Water for Unconventional Oil and Gas
- ▣ “Energy for Water”
  - Managing the energy demands of extracting, treating and transporting water
- ▣ Socioeconomic Barriers and Opportunities
  - Social, behavioral, policy, and economic structures to enhance water and energy use efficiencies
    - ▣ Public
    - ▣ Professional Community

# Process

- ▣ Plenary session for each of the four topics
- ▣ Introduced by 2 lectures with relevant data and background information outlining the key challenges and opportunities as they now exist and provoke further thinking and discussion on current and future needs and how they might be addressed.
- ▣ Breakouts on each session's topic focusing on **technical, social and policy barriers**.
  - 2 groups of 25-30, 1 group for the balance
  - The lectures will be used to charge those breakouts and to initiate discussion.
  - Each breakout will have a facilitator and a student rapporteur
  - Organizers to further promote discussion and dialog

# **Research & Data at the Energy-Water Nexus: Update on U.S. Dept of Energy & Federal Agency Activity**

Roundtable on Science and Technology for Sustainability

Presented by National Research Council

June 6, 2013

Holmes Hummel

Senior Policy Advisor

Office of the Undersecretary for Energy

U.S. Department of Energy

# Federal Partners in Energy-Water Nexus Research & Data

- National Interests in Intelligence in the Energy Water Nexus
- U.S. Department of Energy's Water-Energy Technology Team
- Interagency – Intergovernmental Engagement on Data
- Preparing for Hazards and Recovering from Disaster



# Global Water Security

## INTELLIGENCE COMMUNITY ASSESSMENT

ICA 2012-08, 2 February 2012

### Global Water: Present to 2025

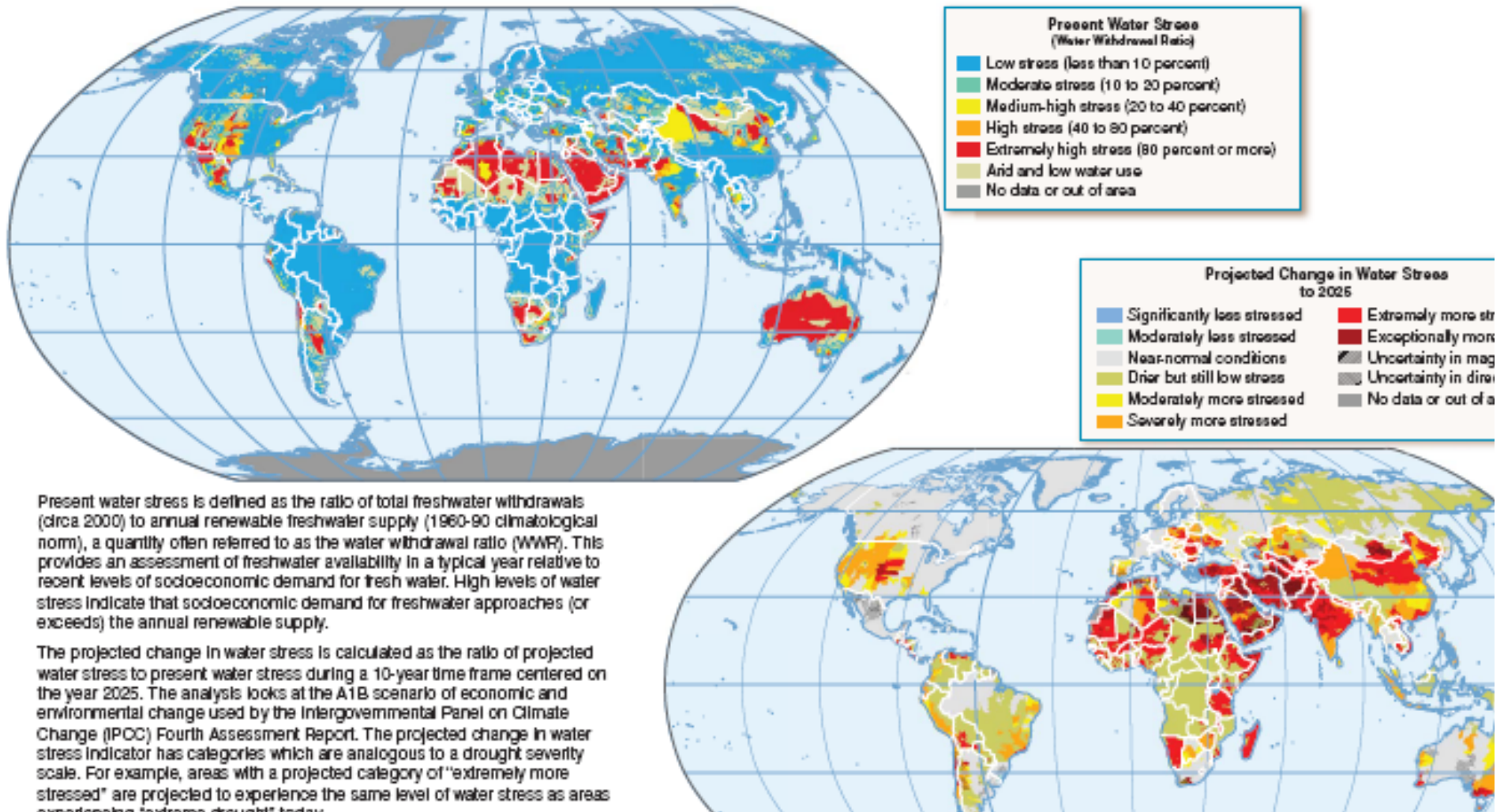

# U.S. water withdrawals by category: 2005

Surface water 328,000 Mgal/d (80%), 82% freshwater  
Groundwater: 82,600 Mgal/d (20%), 96% freshwater  
Total: 410,000 Mgal/d

Livestock



Less than 1 percent

Self-Supplied Domestic



1 percent

Public Supply



11 percent

Thermoelectric Power



49 percent

1 percent



Mining

2 percent



Aquaculture

4 percent



Self-Supplied Industrial

31 percent



Irrigation

Source: Kenny et al., *Estimated Use of Water in the United States in 2005: U.S. Geological Survey Circular 1344*, 2009

Slide: Presented by Robin Newmark, National Renewable Energy Lab, to Nat'l Academy of Sciences workshop, April 2013.

# Primary energy embedded in water\*: US national-level

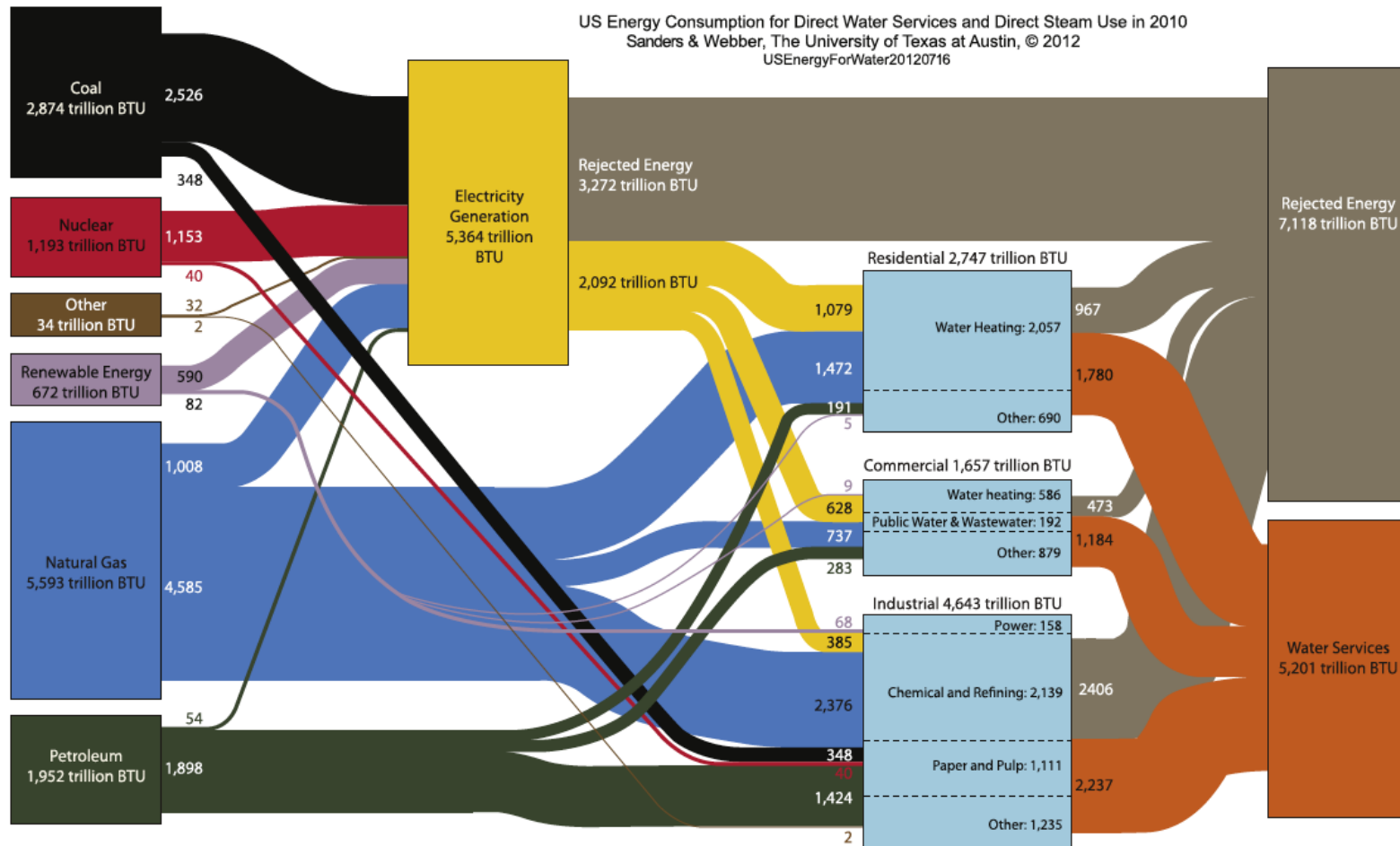

\*Residential, Commercial, Industrial and Power sectors, (~70% of total US primary energy consumption). Transportation sector not included.

Source: Sanders and Webber, 2012

# Primary energy embedded in water\*: US national-level

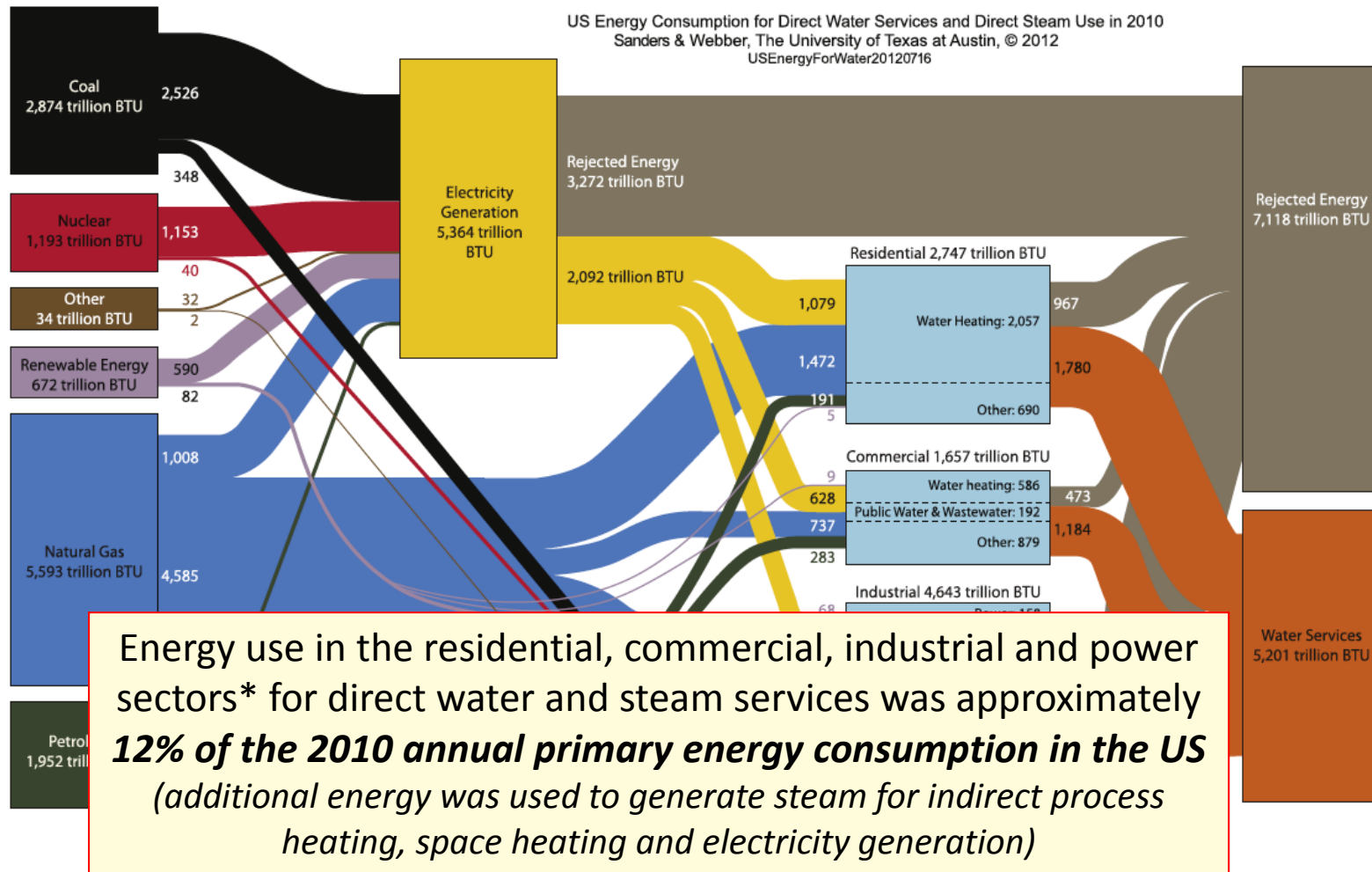

\*Residential, Commercial, Industrial and Power sectors, (~70% of total US primary energy consumption). Transportation sector not included.

Source: Sanders and Webber, 2012



# **Federal Partners in Energy-Water Nexus Research & Data**

- **National Interests in Intelligence in the Energy Water Nexus**
- **U.S. Department of Energy's Water-Energy Technology Team**
- **Interagency – Intergovernmental Engagement on Data**
- **Preparing for Hazards and Recovering from Disaster**

# DOE Offices with Water-Energy Equities



## DEPARTMENT OF ENERGY

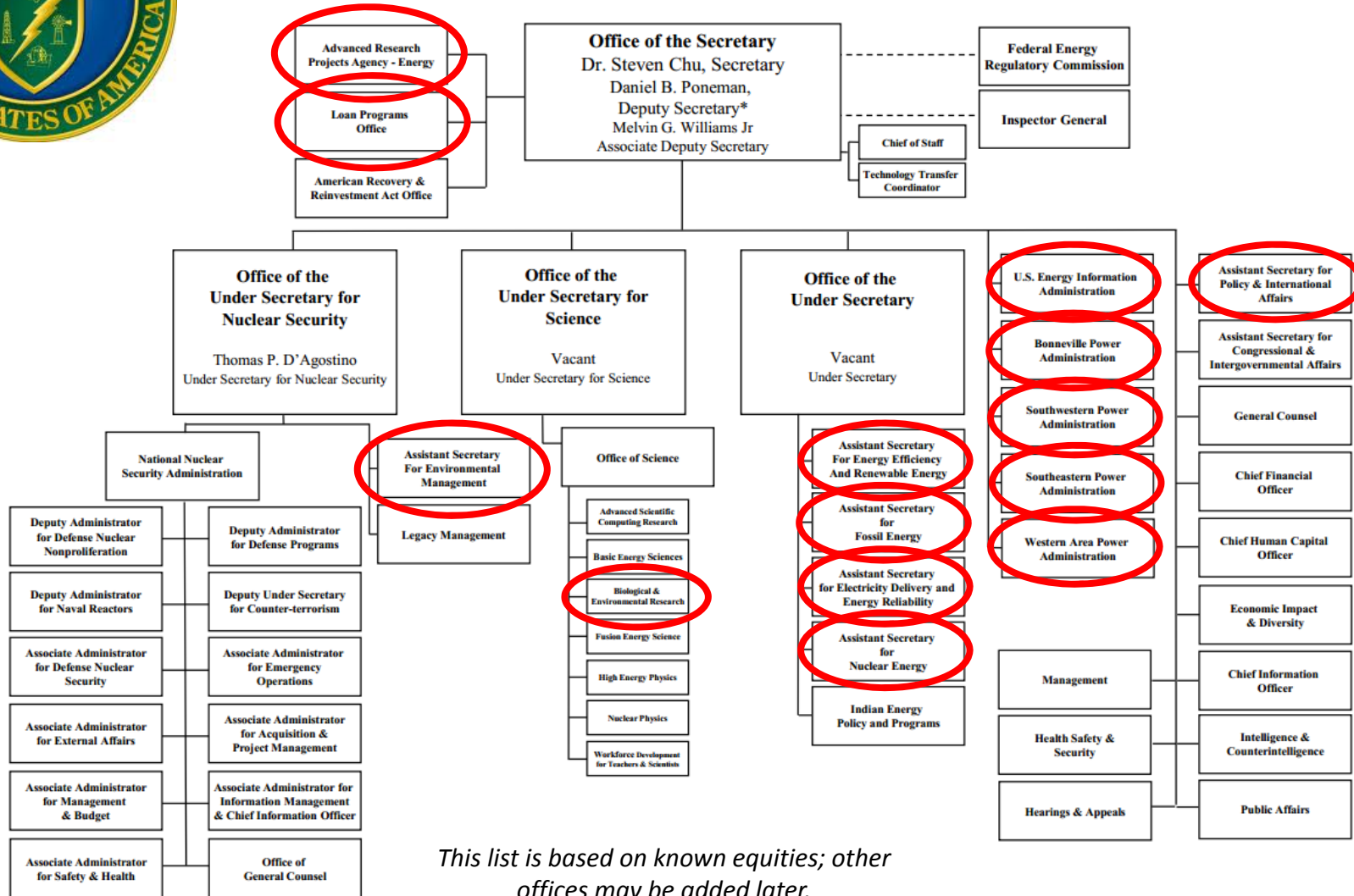

*This list is based on known equities; other offices may be added later.*

# DOE Water-Energy Technology Team

*50+ experts in 20+ programs*



**Cooling  
Technologies**

**Water in Fuels  
Production**

**Monitoring,  
Modeling and  
Forecasting**

**Three working groups to start,  
plus delegation to support EPA on wastewater treatment.**

# DOE Cooling Technologies Working Group

- **Reject less heat**
  - Improve plant efficiency
  - Use waste heat in other processes
- **Improve dry and hybrid wet/dry cooling**
  - Thermal barrier coatings
  - Rotating heat exchanger, novel heat sinks
- **Recover cooling tower water with minimal efficiency penalties**
- **Develop materials resistant to scaling, corrosion, and biofouling to enable use of degraded waters for cooling**
- **Alternative high temperature working fluids**
  - e.g. supercritical CO<sub>2</sub>



# DOE **Water in Fuels Production** Working Group

- **Look before drilling: High resolution seismic imaging**
  - Identify/avoid naturally-occurring fracture zones
- **Improve wellbore integrity sensors**
  - High temperature, high pressure, real-time telemetry
- **Use alternatives to water as hydraulic fracturing fluid**
  - Also non or less toxic additives
- **Improve hydraulic fracturing fluid life cycle management**
- **Treat produced water at lower cost, lower energy**
  - Forward osmosis, membrane distillation, dewvaporation, capacitive deionization
  - Suitable for highly saline waters (e.g. Marcellus shale)
  - Utilize waste heat where feasible
  - Enhanced membrane separations



EPA + USGS + DOE  
MOU on R&D for  
Unconventional Gas

# DOE Monitoring, Modeling, and Forecasting Working Group



- **Water availability and temperature**
- **Assess power plants vulnerabilities to extreme weather**
  - Thermoelectric
  - Hydropower
- **Integrated assessment of future water uses and availability**
  - Climate change
  - Population shifts
  - Alternative usages scenarios
  - Competing demands (e.g. agriculture, municipal, industrial, energy)
- **Integrate water into biofuels production models/assessments**

**DOE Water-Energy  
Technology Team**  
*50+ experts in 20+ programs*



**Cooling  
Technologies**

**Water in Fuels  
Production**

**Monitoring,  
Modeling and  
Forecasting**

**Three working groups to start,  
plus delegation to support EPA on wastewater treatment.**

# Energy in Water Treatment and Distribution

- **Improve energy efficiency in wastewater treatment**
  - Membrane technologies
  - Update efficiency standards for pumps
- **Energy and resource extraction from wastewater streams**
  - Municipal biogas
- **Management of water and energy as integrated system**
  - Demand response in municipal wastewater treatment
  - Coupling desalination, municipal wastewater/storm water, and renewable generation
- **Energy assurance for water infrastructure**



# **Federal Partners in Energy-Water Nexus Research & Data**

- **National Interests in Intelligence in the Energy Water Nexus**
- **U.S. Department of Energy's Water-Energy Technology Team**
- **Interagency – Intergovernmental Engagement on Data**
- **Preparing for Hazards and Recovering from Disaster**

# Federal Participants in the Energy-Water Landscape of Activity (partial view)



**US Army Corps  
of Engineers®**



# Energy-Water Landscape of Activity (partial view)

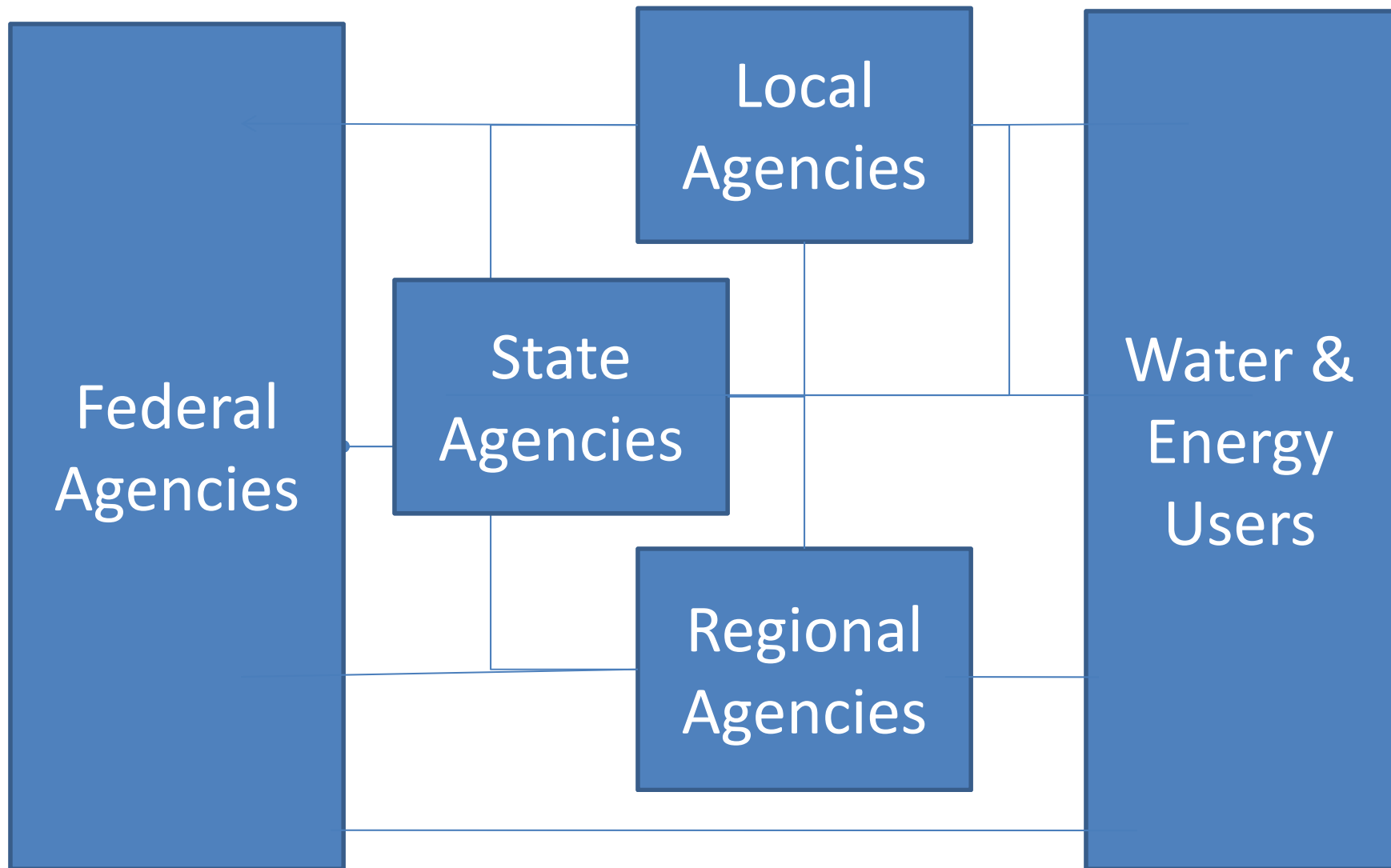



# WaterToolBox.US

## DATABASES, TOOLS & MODELS

*Access water resources management programs, databases and models created by the U.S. federal government, states, Tribal Nations and non-governmental organizations by keyword or map search*

- [Search active databases](#) for water management
- [Access models](#) that facilitate analysis & predictions
- [Acquire new tools and technologies](#)
- [Search by location](#) for data, models and programs

## COLLABORATION & COMMUNITY

*Contribute and take advantage of water resource solutions*

- [View existing collaborations & partnerships](#)
- [Be aware of needs](#) within the water resources community
- Visit the [water resources forum](#) to learn about water activities and issues
- Find out how to become a [Federal Support Toolbox partner](#)

## GET INVOLVED

*Become a part of the Water Toolbox community*

- [Become a Federal Support Toolbox partner](#)
- Stay informed about the latest [headline news and upcoming events](#)
- Join in the [discussion forums](#)

## WATER RESOURCES MANAGEMENT

*Effective water resources management depends on acquiring deep knowledge and astute skills*

- Search the list of [legislative resources](#)
- Locate specific [policies and guidance](#)
- Review [best management practices](#)
- View the [list of agencies](#)

## Water and energy studies

*From Open Energy Information*

Author	Year	Title	External Link	Topic
UC Berkeley/M. Kiparsky	2013	Regulation of Hydraulic Fracturing in California: A Wastewater and Water Quality Perspective	<a href="#">Report</a> 	Hydraulic fracturing
EPRI/Revis James,R. Breckenridge	2013	Water Management Technology (P185) Program Overview	<a href="#">Program overview</a>	Water management, electric power plants
IEA/Coal Industry Advisory Board	2013	21st Century Coal: Advanced Technology and Global Energy Solution	<a href="#">Report</a> 	Coal energy water use
CRS/K. Bracmort	2013	Hydropower: Federal and Nonfederal Investment	<a href="#">R42579</a> 	Hydropower
ANL/C. Harto	2013	Geothermal Energy: The Energy-Water Nexus	<a href="#">38th Workshop on Geothermal Energy Engineering</a> 	Water intensity of energy
U. Alberta/Evan G.R. Davies	2013	An integrated assessment of global and regional water demands for electricity generation to 2095	<a href="#">ADVANCES IN WATER (2013)</a> 	Energy intensity of water, water intensity of energy, planning
CPUC/R. White	2013	Rethinking the Water Energy Nexus: Moving toward Portfolio Management of the Nexus	<a href="#">Report</a> 	Energy intensity of water, water intensity of energy, planning
Carbon Disclosure Project	2012	Collective responses to rising water challenges	<a href="#">Report</a> 	Energy intensity of water, water intensity of energy, planning
Pacific Institute	2012	Hydraulic Fracturing and Water Resources: Separating the Frack from the Fiction	<a href="#">Report</a> 	Hydraulic fracturing
PNNL/R. Skaggs	2012	Climate and Energy-Water-Land System Interactions: Technical Report to the U.S. Department of Energy in Support of the National Climate Assessment	<a href="#">PNNL-21185</a> 	Planning
AGU	2012	Water-Energy Nexus: Solutions to Meet a Growing Demand	<a href="#">Report</a> 	Water intensity of energy, energy intensity of water

# **Federal Partners in Energy-Water Nexus Research & Data**

- **National Interests in Intelligence in the Energy Water Nexus**
  - **U.S. Department of Energy's Water-Energy Technology Team**
  - **Interagency – Intergovernmental Engagement on Data**
- **Preparing for Hazards and Recovering from Disaster**



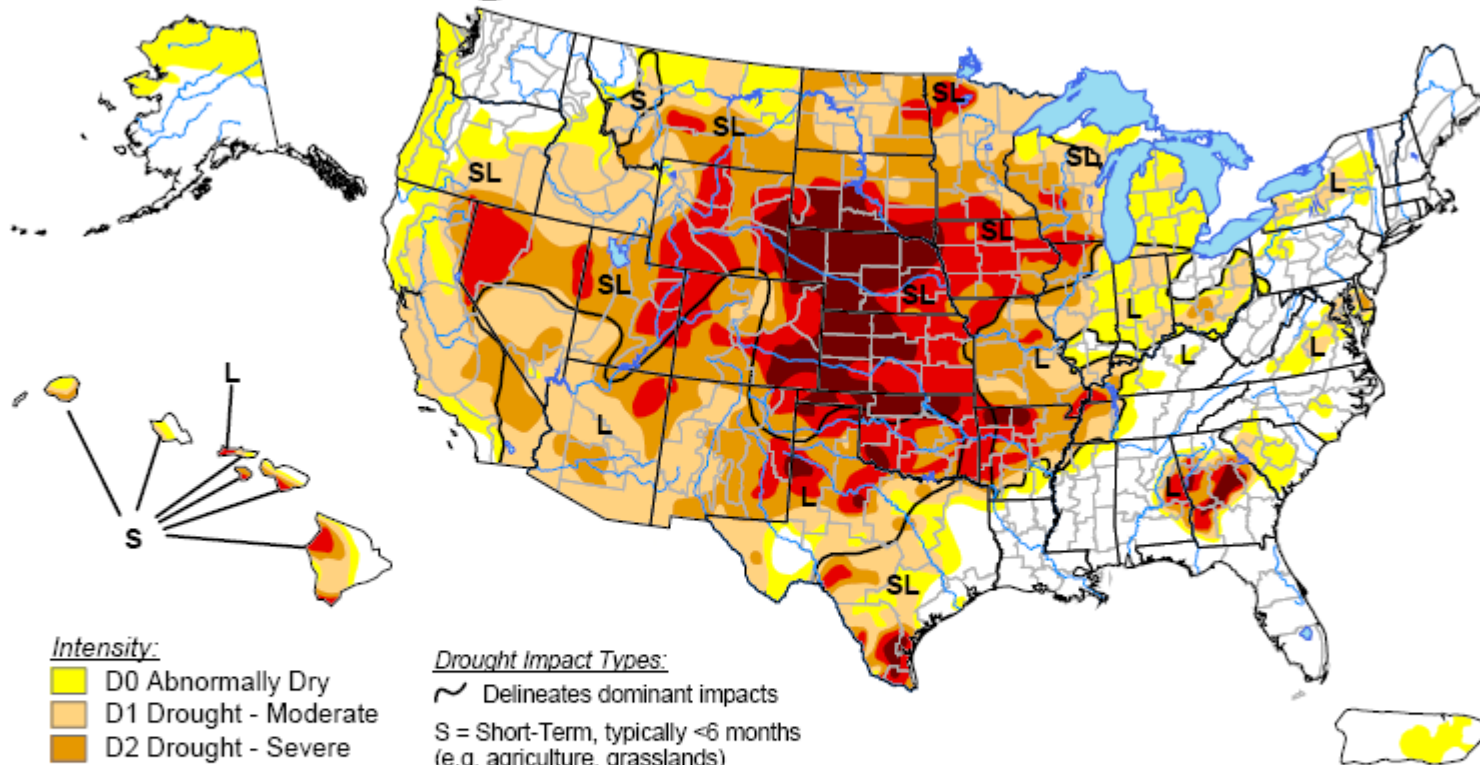

# U.S. Drought Monitor

October 9, 2012

Valid 7 a.m. EDT



## Intensity:

-  D0 Abnormally Dry
-  D1 Drought - Moderate
-  D2 Drought - Severe
-  D3 Drought - Extreme
-  D4 Drought - Exceptional

## Drought Impact Types:

-  Delineates dominant impacts
- S = Short-Term, typically <6 months (e.g. agriculture, grasslands)
- L = Long-Term, typically >6 months (e.g. hydrology, ecology)

*The Drought Monitor focuses on broad-scale conditions. Local conditions may vary. See accompanying text summary for forecast statements.*

<http://droughtmonitor.unl.edu/>





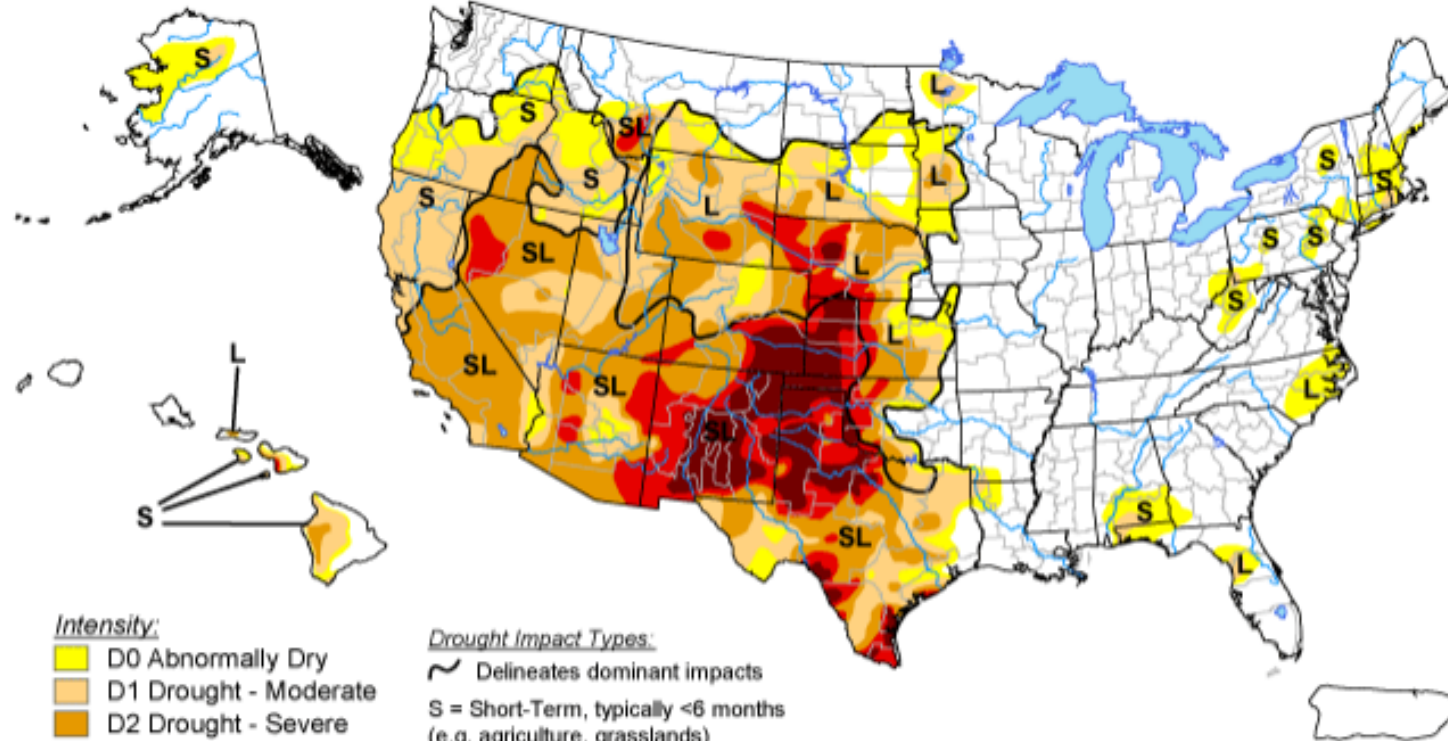

Released Thursday, October 11, 2012  
Author: Matthew Rosencrans, NOAA/NWS/NCEP/CPC

# U.S. Drought Monitor

June 4, 2013  
Valid 7 a.m. EDT



Intensity:

-  D0 Abnormally Dry
-  D1 Drought - Moderate
-  D2 Drought - Severe
-  D3 Drought - Extreme
-  D4 Drought - Exceptional

Drought Impact Types:

-  Delineates dominant impacts
- S = Short-Term, typically <6 months (e.g. agriculture, grasslands)
- L = Long-Term, typically >6 months (e.g. hydrology, ecology)

The Drought Monitor focuses on broad-scale conditions. Local conditions may vary. See accompanying text summary for forecast statements.

<http://droughtmonitor.unl.edu/>

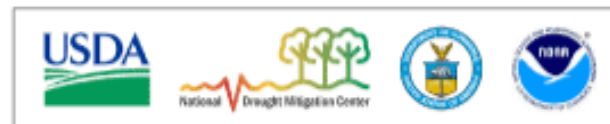

Released Thursday, June 6, 2013

Author: David Simeral, Western Regional Climate Center



# U.S. Water Monitor -- A Portal To Federal Water Information -April 30, 2013

Companion to the *U.S. Drought Monitor* and the *Drought Impact Reporter*

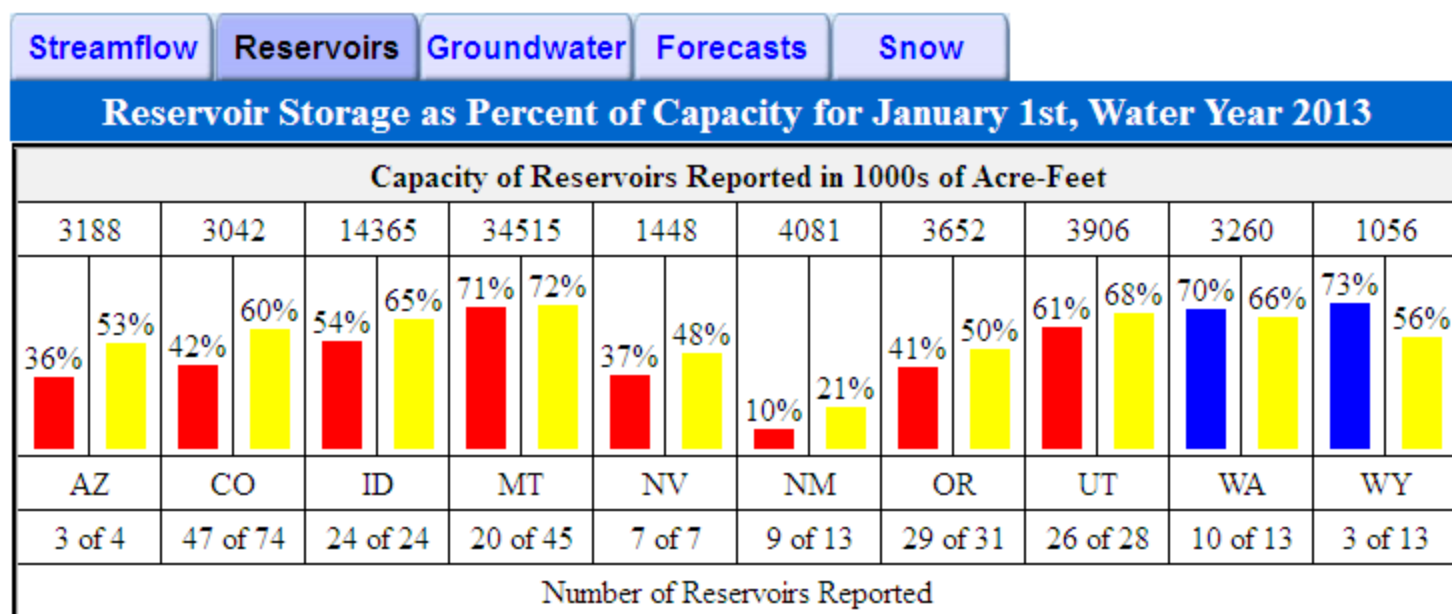

■ Storage is Below Average (% of Capacity)  
■ Storage is At or Above Average (% of Capacity)  
■ Average Storage as % of Capacity  
 \* = Data are not available for this state.

# Hurricane Tracks for Last 150 Years

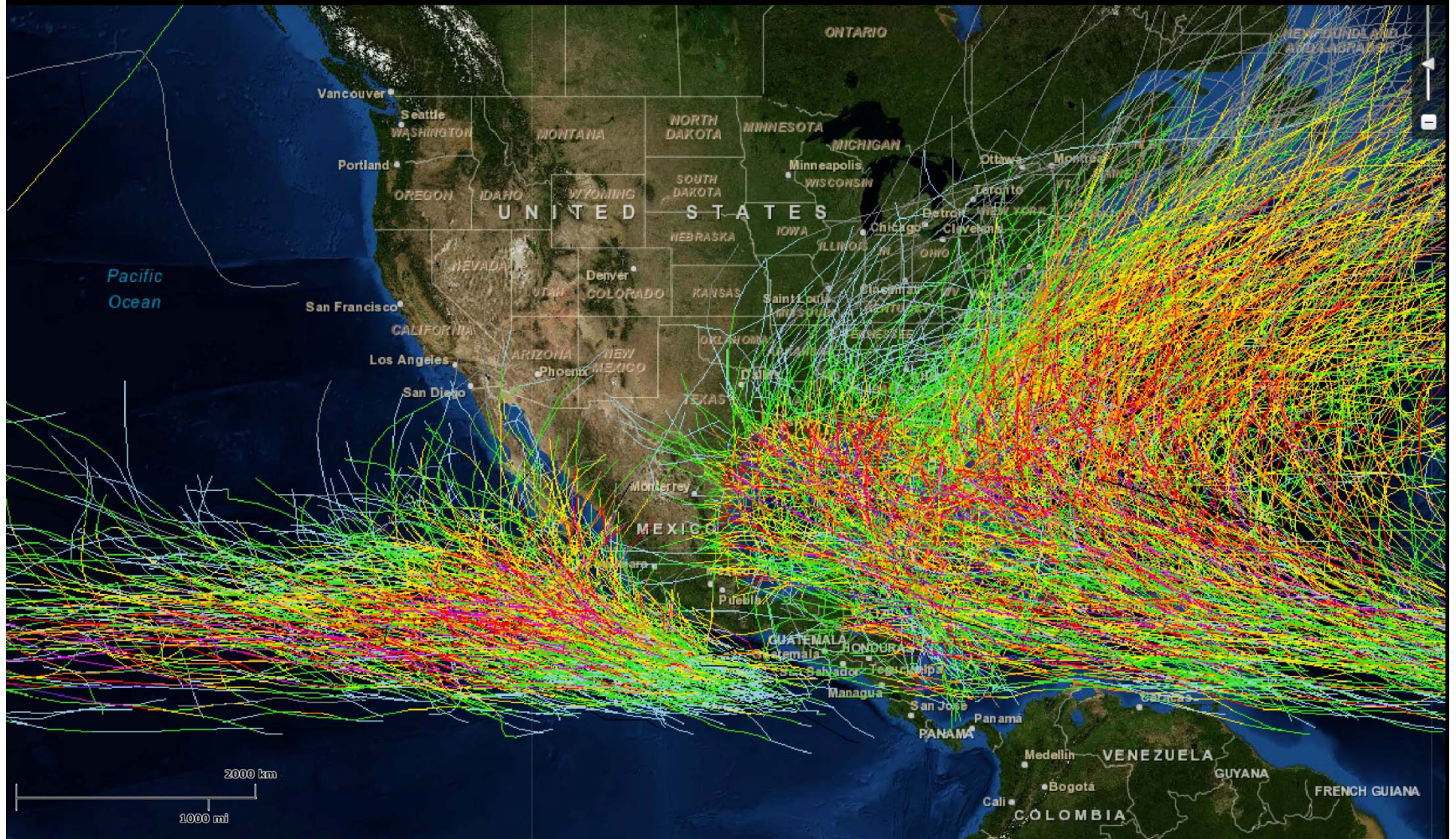

<http://www.commerce.gov/sites/default/files/images/2012/august/noaa-hurricane-tracker.jpg>

# Presidential Policy Directive #8 (PPD-8): National Preparedness

## Prepare for Hazards, Respond to Disaster, and Recover:

**Mitigation:** the capabilities necessary to reduce the loss of life and property by lessening the impact of disasters.

**Response:** the capabilities necessary to save lives, protect property and the environment, and meet basic human needs after an incident has occurred.

**Recovery:** the core capabilities necessary to assist communities affected by an incident to recover effectively.



# National Mitigation Framework

*May 2013*

Mitigation requires systemically anticipating and adjusting to trends that could endanger the future of the community.

Appropriate choices made before an event can help to manage or reduce long-term risk and potentially reduce response requirements.

Mitigation during the recovery phase helps strengthen and build a more resilient community to withstand future disasters.

# Examples of Threats and Hazards by Category

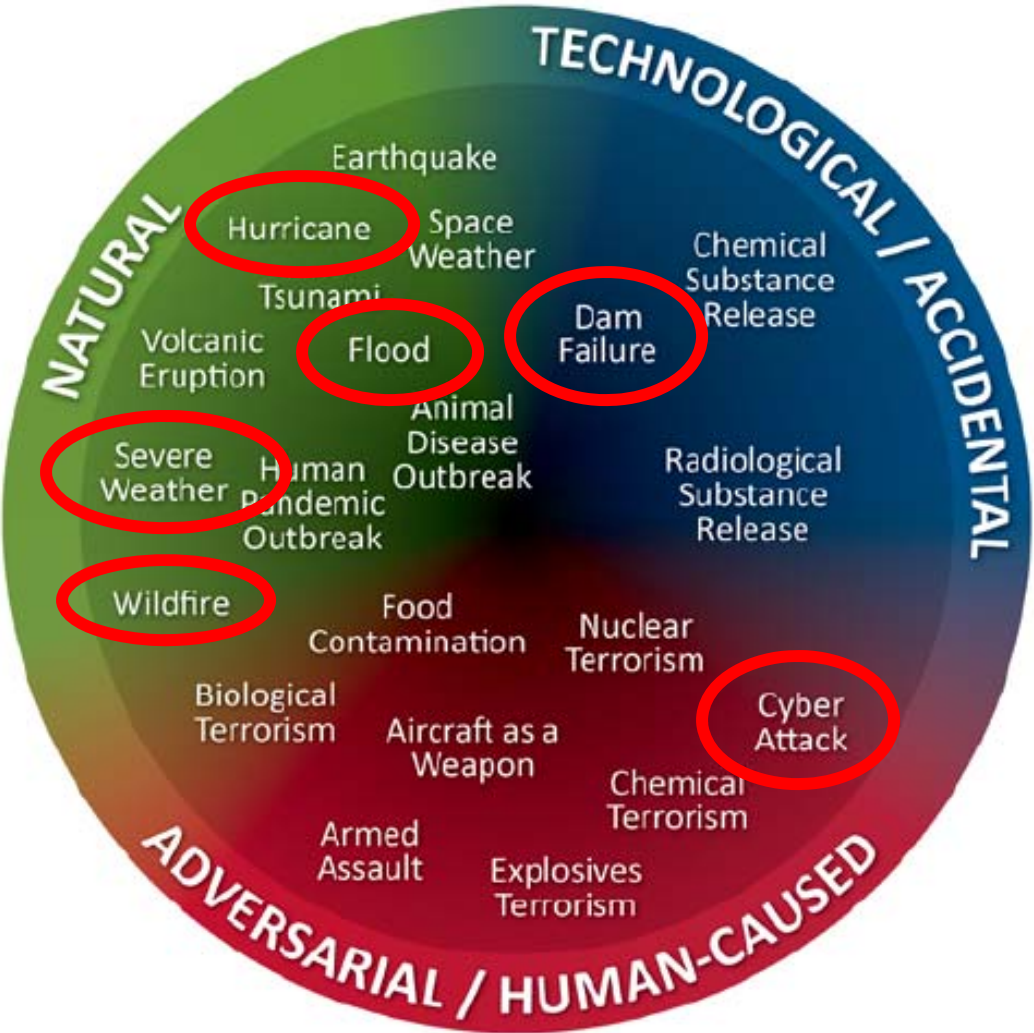

# Composition of the Whole Community



# Comprehensive Mitigation Includes Strategies for All Community Systems



# Mitigation Core Capabilities





**1 Mitigation:** “the capabilities necessary to reduce the loss of life and property by lessening the impact of disasters.”

**Presidential Policy Directive #8:  
National Preparedness**

**PPD-8**

**2 Response:** “the capabilities necessary to save lives, protect property and the environment, and meet basic human needs after an incident has occurred.”

**3 Recovery:** “the core capabilities necessary to assist communities affected by an incident to recover effectively.”

**1 Mitigation:** “the capabilities necessary to reduce the loss of life and property by lessening the impact of disasters.”

Core Capabilities

- Planning
- Public Information and Warning
- Operational Coordination
- Community Resilience
- Long-Term Vulnerability Reduction
- Risk and Disaster Resilience Assessment
- Threats and Hazard Identification

**3 Recovery:** “the core capabilities necessary to assist communities affected by an incident to recover effectively.”

- Planning
- Public Information and Warning
- Operational Coordination
- Economic Recovery
- Health and Social Services
- Housing
- Infrastructure Systems
- Natural and Cultural Resources

## Presidential Policy Directive #8: National Preparedness

# PPD-8

**2 Response:** “the capabilities necessary to save lives, protect property and the environment, and meet basic human needs after an incident has occurred.”

- Planning
- Public Information and Warning
- Operational Coordination
- Critical Transportation
- Environmental Response/Health and Safety
- Fatality Management Services
- Infrastructure Systems
- Mass Care Services
- Mass Search and Rescue Operations
- On-Scene Security and Protection
- Operational Communications
- Public and Private Services and Resources
- Public Health and Medical Services
- Situational Assessment

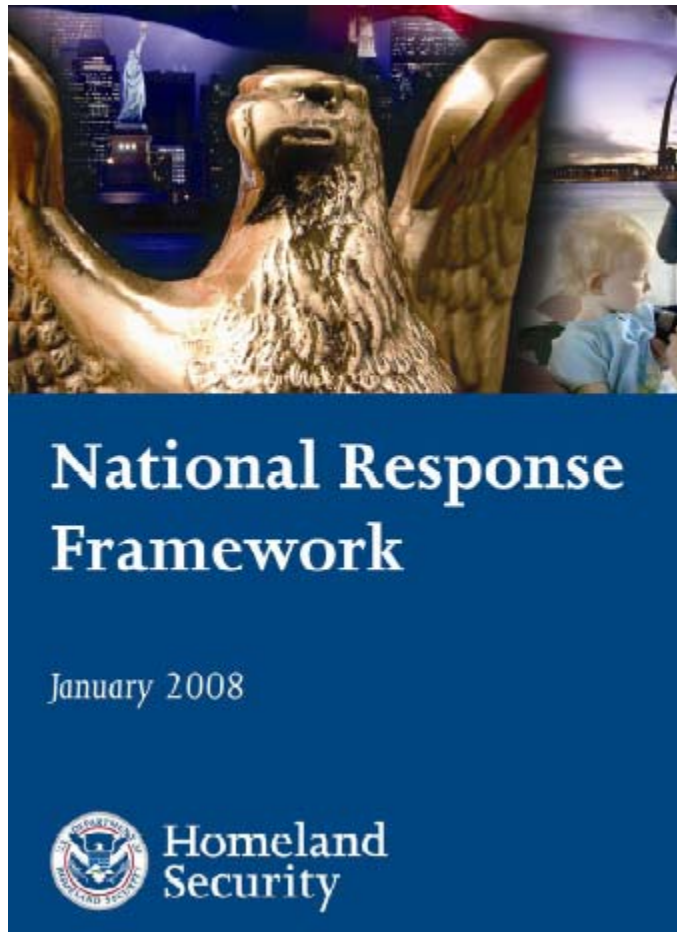

*During Superstorm Sandy,  
428 Drinking Water Plants and  
120 Wastewater Treatment Plants  
sustained damage.*

## **Emergency Support Function #3: Public Works**

### **ESF Coordinator:**

Department of Defense/U.S. Army Corps of Engineers

### **Primary Agencies:**

Department of Defense/U.S. Army Corps of Engineers  
Department of Homeland Security/Federal Emergency Management Agency

### **Support Agencies:**

Department of Agriculture  
Department of Commerce  
Department of Defense  
Department of Energy  
Department of Health and Human Services  
Department of Homeland Security  
Department of the Interior  
Department of Labor  
Department of State  
Department of Transportation  
Department of Veterans Affairs  
Environmental Protection Agency  
General Services Administration  
Nuclear Regulatory Commission  
Tennessee Valley Authority  
American Red Cross  
Corporation for National and Community Service

# National Disaster Recovery Framework

Strengthening Disaster Recovery for the Nation

September 2011



## RSF: INFRASTRUCTURE SYSTEMS

Coordinating Agency: DOD/USACE

Primary Agencies: DHS (FEMA & NPPD), DOD/USACE, DOE, DOT

Supporting Organizations: DHS, DOC, DOD, DOI, ED, EPA, FCC, GSA, HHS, NRC, TREAS, USDA, TVA

### **Provides the coordinating structures, framework and guidance to ensure:**

- Resilience, sustainability, and mitigation are incorporated as part of the design for infrastructure systems and as part of the community's capital planning process.

### **Pre-Disaster:**

- Works with partners to identify critical facilities and help reduce risk.

### **Post-Disaster:**

- Promotes rebuilding infrastructure in a way that will reduce vulnerability to future disasters.

# Comprehensive Mitigation Includes Strategies for All Community Systems



# **Federal Partners in Energy-Water Nexus Research & Data**

- **National Interests in Intelligence in the Energy Water Nexus**
- **U.S. Department of Energy's Water-Energy Technology Team**
- **Interagency – Intergovernmental Engagement on Data**
- **Preparing for Hazards and Recovering from Disaster**

# **Research & Data at the Energy-Water Nexus: Update on U.S. Dept of Energy & Federal Agency Activity**

Roundtable on Science and Technology for Sustainability

Presented by National Research Council

June 6, 2013

Holmes Hummel

Senior Policy Advisor

Office of the Undersecretary for Energy

U.S. Department of Energy



# ***An Energy Water Nexus Research Agenda***

**NSF Workshop on the Energy Water Nexus**

**Michael E. Webber, Ph.D.  
June 10, 2013**



# ***There Are Good and Bad Tradeoffs At the Energy Water Nexus (Quantity)***

- **With sufficiently abundant, clean and affordable energy, our water problems are solved**
  - Long-haul transfer, desalination, deep wells,...
- **With sufficiently abundant, clean, and affordable water, our energy problems are solved**
  - Biofuels, hydro,...
- **Coupled infrastructures causes cascading vulnerabilities**
  - Water constraints become energy constraints
  - Energy constraints become water constraints



# *There Are Good and Bad Tradeoffs At the Energy Water Nexus (Quality)*

- **Energy affects water quality (good and bad)**
  - Energy is used to treat (clean, move, heat,...)
  - Energy pollutes water (thermal, chemical,...)
- **Water affects energy quality (good and bad)**
  - Improved efficiency at power plants (thermoelectric, solar PV, ...)
  - Improved recovery for oil and gas production
  - Degraded performance in heat waves



# ***We Use Water for Energy***

- **We use water for the power sector**
  - **Driving hydroelectric turbines**
  - **Driving steam turbines**
  - **Cooling power plants**
- **We use water for fuels production**
  - **Growing biofuels**
  - **Extracting oil and gas**
  - **Mining coal and uranium**
  - **Refining/upgrading fuels**
- **We use water for transporting fuels**



# *The Thermoelectric Power Sector Is Water Intensive*

- *Non-Consumptive Use (Withdrawals):*
  - ~0.2 to 42.5 gal/kWh
  - 48% of total USA water withdrawals
  - 39% of total USA freshwater withdrawals
- *Consumptive Use:*
  - ~0.1 to 0.8 gal/kWh
  - 3% of USA consumption
- *Varies by fuel, power cycle, cooling technology*



# Transportation Is Water Intensive & Growing

## Water Intensity of Transportation

Source: Recreated from King & Webber (2008) and Twomey, Beal, King & Webber (2012)  
 Graphic: Michael E. Webber, The University of Texas at Austin

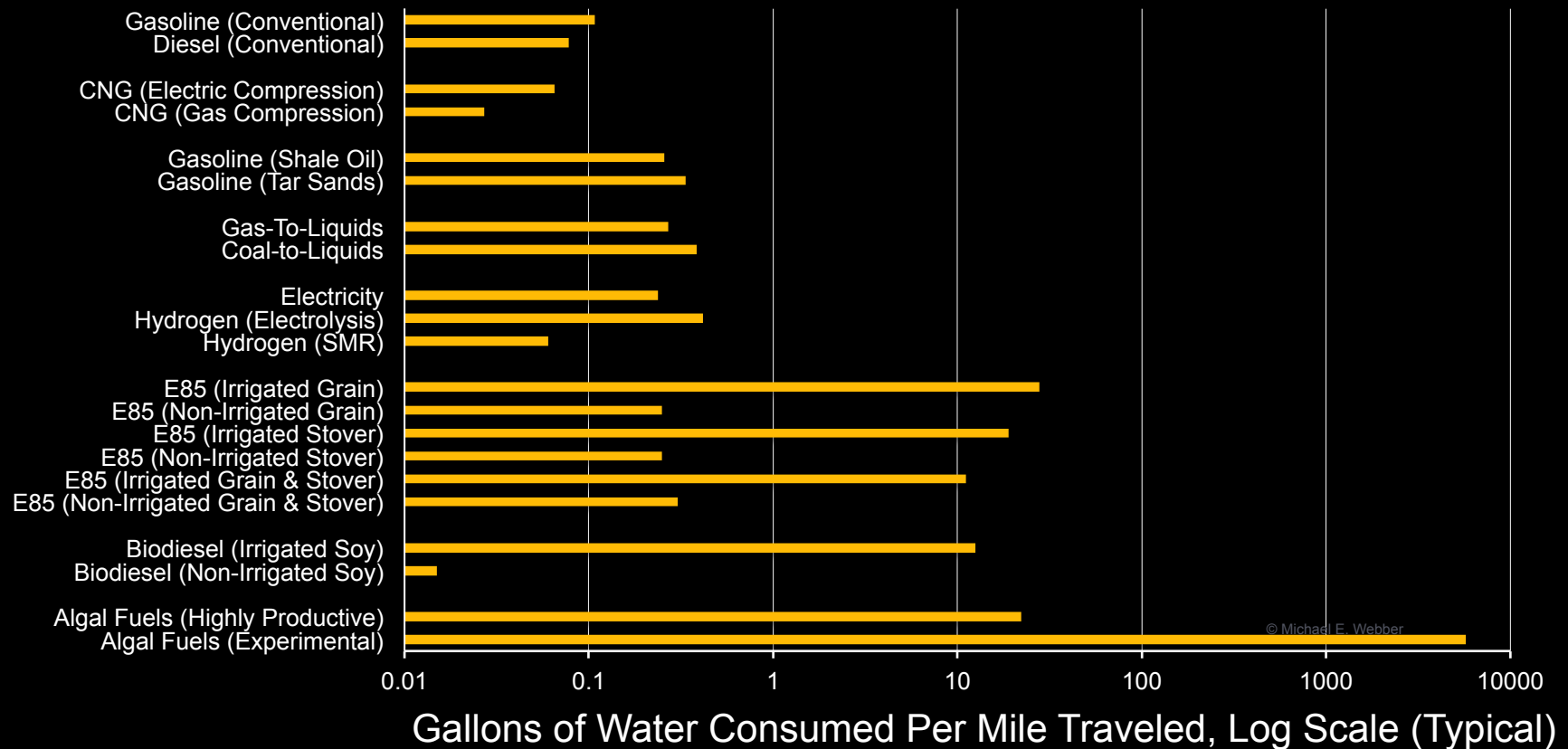

# *We Use Water For Transporting Energy*



# Nearly Half of Global Oil Production Is Traded Across Borders, Much of It By Water

Major trade movements 2011  
Trade flows worldwide (million tonnes)

Source: BP Statistical Review 2012

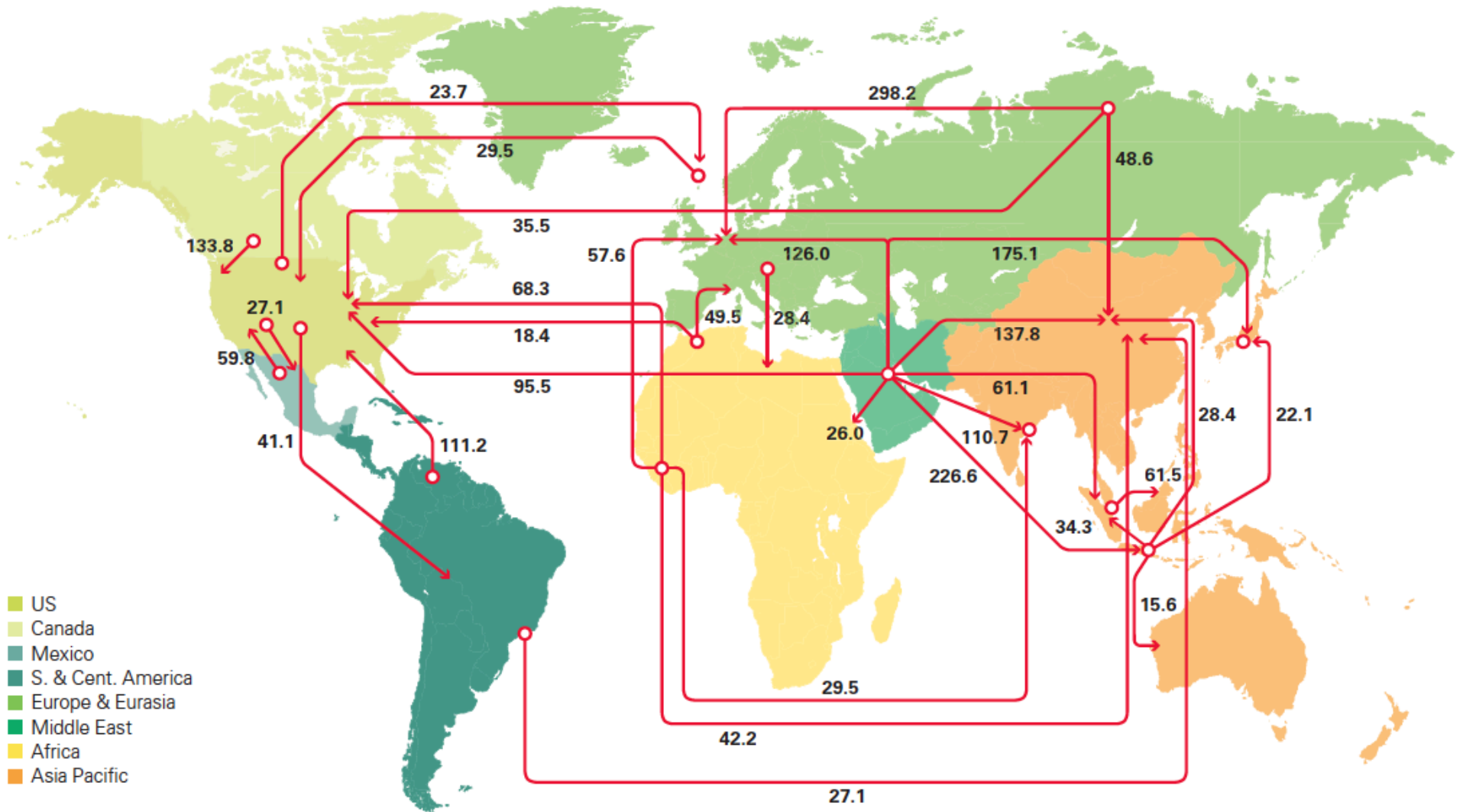

# Most Inland USA Water-Based Transportation Is In the Mississippi River Basin

Tonnage on Highways, Railroads and Inland Waterways: 2002

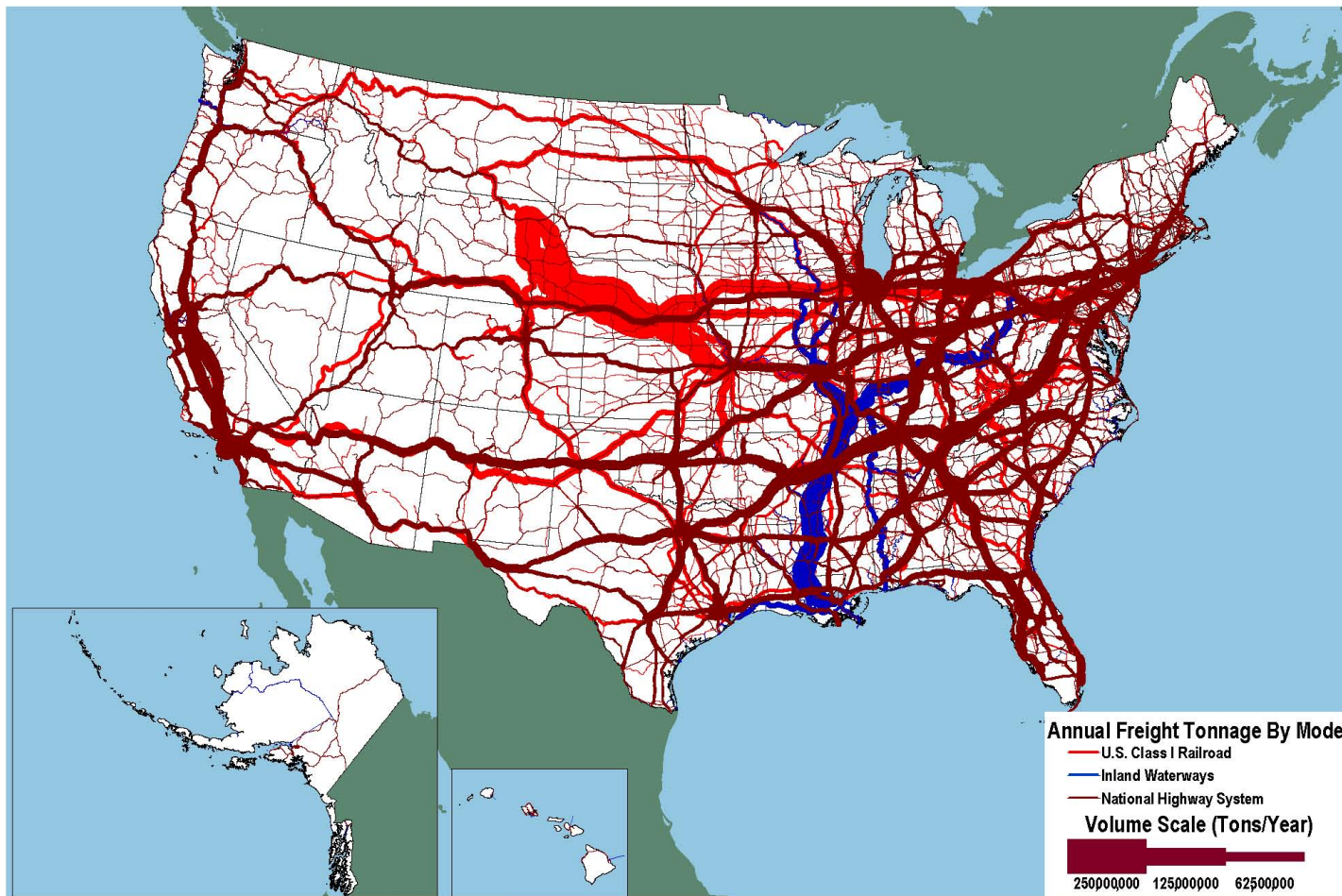

Barges are used to move coal along the Mississippi River

Source:  
U.S. DoT, FHWA

Sources: Highways: U.S. Department of Transportation, Federal Highway Administration, Freight Analysis Framework, Version 2.2, 2007. Rail: Based on Surface Transportation Board, Annual Carload Waybill Sample and rail freight flow assignments done by Oak Ridge National Laboratory. Inland Waterways: U.S. Army Corps of Engineers (USACE), Annual Vessel Operating Activity and Lock Performance Monitoring System data, as processed for USACE by the Tennessee Valley Authority; and USACE, Institute for Water Resources, Waterborne Foreign Trade Data, Water flow assignments done by Oak Ridge National Laboratory.

Michael E. Webber, Ph.D.  
Energy Water Nexus  
June 10, 2013



# *Water Shipping Is Relatively Energy Efficient*

<b>Freight Mode</b>	<b>Energy Intensity [BTU per ton-mile]</b>
Heavy Trucks*	850 to 1075
Freight Railroad	289
Waterborne	217

\*Typical loads for heavy trucks are 20-25 tons

Source: DoE Transportation Energy Data Book 2012  
(2010 Data)



# *We Use Energy for Water*



# The Hydrological Cycle is Global and Has Plenty of Water, But In the Wrong Place, Form, or Time of Year

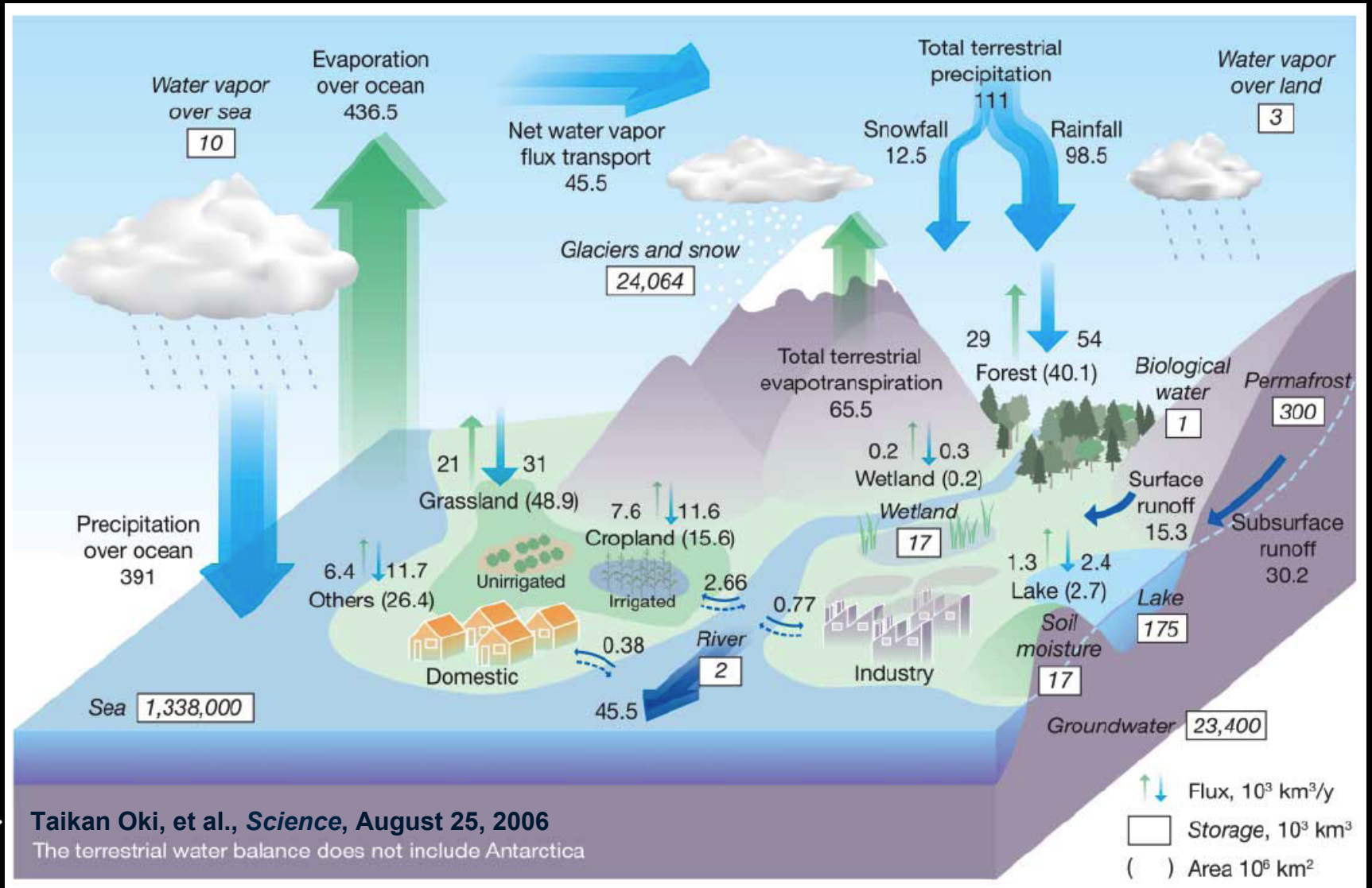

# *Consequently, We Use Energy for Water*

- Conveyance
- Treating
- Heating, pressurizing, chilling



# Direct Water and Direct Steam Services: 12.3 Quads

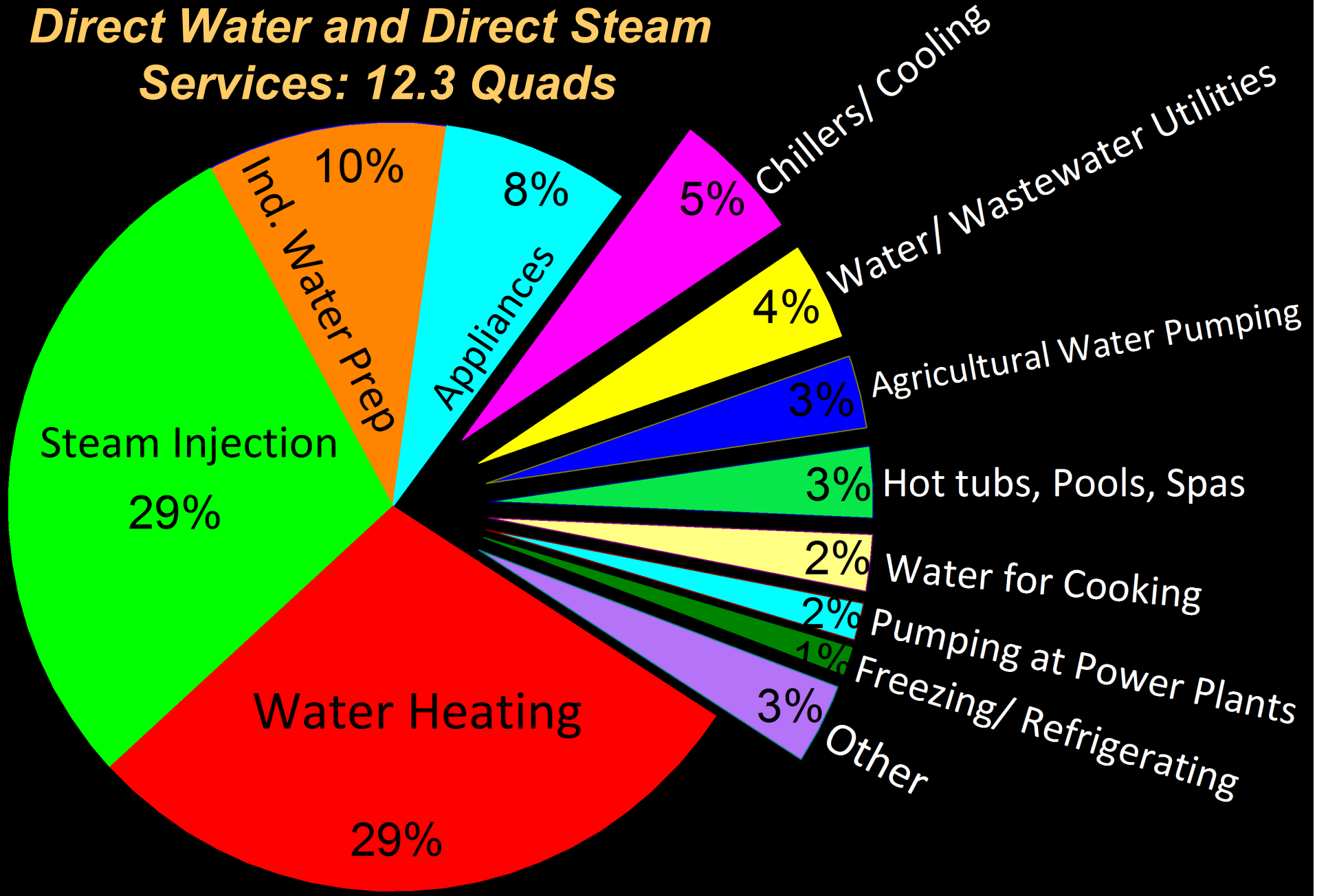

[Sanders and Webber 2012]

Michael E. Webber, Ph.D.  
Energy Water Nexus  
June 10, 2013

# *The Energy-Water Relationship Is Already Under Strain*



# *The Energy-Water Relationship Is Already Under Strain*

- **Water Constraints Become Energy Constraints**
- **Energy Constraints Become Water Constraints**



# *Water Constraints Become Energy Constraints*

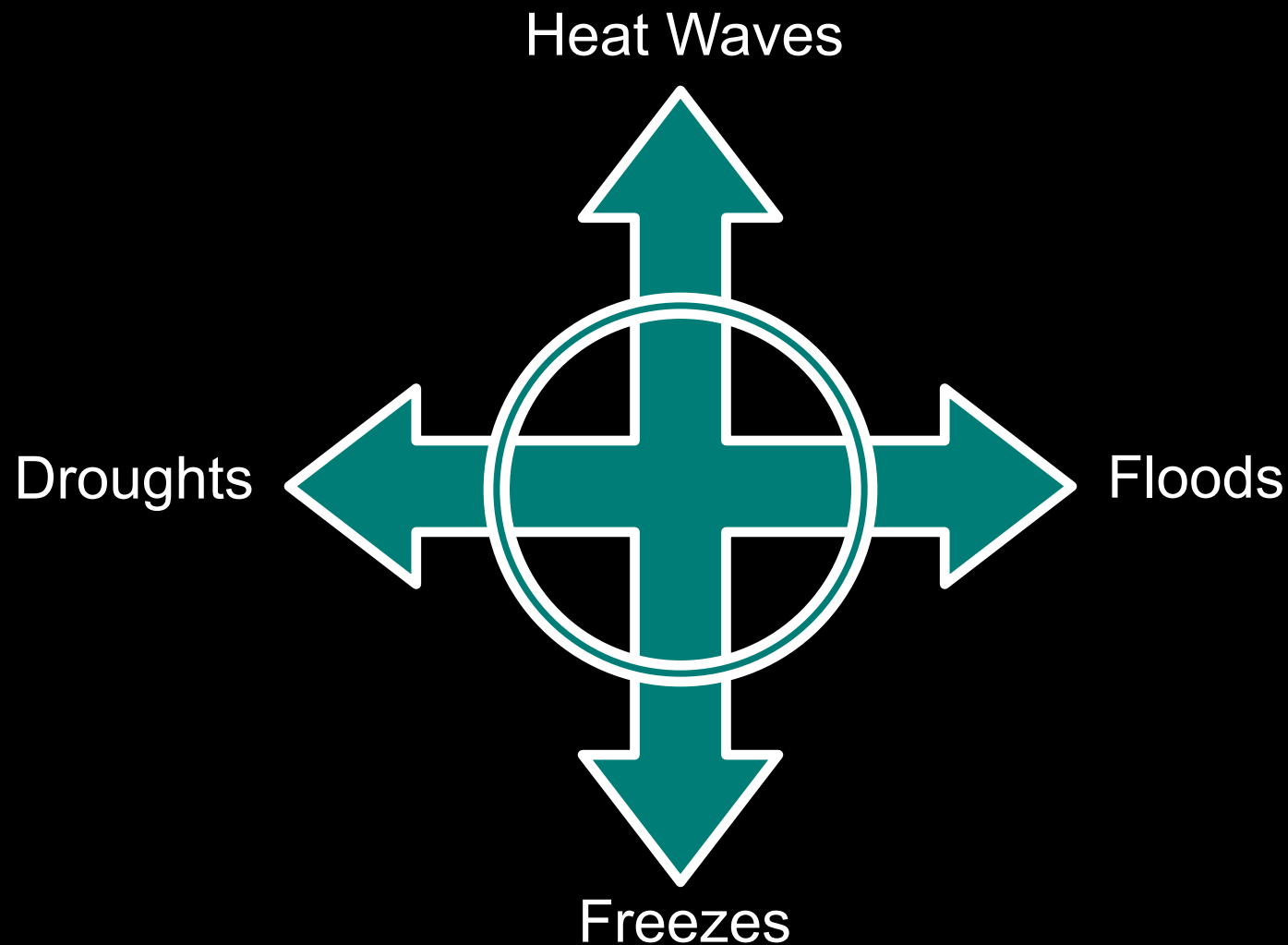



# ***Water Constraints Become Energy Constraints***

- **Record heat wave in France in 2003**
  - nuclear power plants dialed back because of inlet water temperatures (less cooling capability) and rejection water temperature limits
- **Freeze in Texas in February 2011 shut down two coal plants causing statewide rolling blackouts**
- **Droughts:**
  - Nuclear power plants within days of shutting in SE 2008
  - TX power plants at risk of shutting in early 2012
  - Western Hydropower down in drought years
  - Competition for water for hydraulic fracturing
    - Some bans in Texas on water use for fracking
- **Floods:**
  - Nebraska nuclear power plant nearly shut down because of flooding of the Missouri River in June 2011



# *The 2012 Indian Blackout Affected 600 Million People and Was Triggered Partly by Drought*

- 1) Increased power demand from irrigation
- 2) Decreased power generation at dams

**The New York Times**

2nd Day of Power Failures Cripples Wide Swath of India



Adnan Abidi/Reuters

Passengers waited Tuesday for train service to be restored in New Delhi. [More Photos »](#)

By JIM YARDLEY and GARDINER HARRIS  
Published: July 31, 2012 | [429 Comments](#)

Michael E. Webber, Ph.D.  
Energy Water Nexus  
June 10, 2013

# *Drought Hurts the Ability to Ship Energy By Inland Waterways*

**The New York Times**

**After Drought, Reducing Water Flow Could Hurt Mississippi River Transport**



Jeff Roberson/Associated Press

Barges on the Mississippi River in St. Louis on Friday. A plan approved by Congress for maintaining irrigation systems is likely to affect shipping in the region.

By JOHN SCHWARTZ

Published: November 26, 2012

\$7 billion of coal, petroleum products, fertilizer, and agriculture products could not ship in Jan and Feb 2013 because of low water

Michael E. Webber, Ph.D.  
Energy Water Nexus  
June 10, 2013 **20**

# *Energy Constraints Become Water Constraints*

- Hurricane Ike knocked out power to the water system in Houston in 2008

“Our restoration priorities had been established beforehand. First, we secured downed power lines and restored service to key facilities vital to public safety, health and welfare such as hospitals, *wastewater treatment plants and water treatment facilities, including the Trinity River water pumping station: a major source of water for the greater Houston area.*”



Source: Centerpoint Energy, “Hurricane Ike Outage And Restoration Details”

Michael E. Webber, Ph.D.  
Energy Water Nexus  
June 10, 2013

# *There Are Technical, Social and Policy Solutions*



# ***Research Agenda Should Enhance the Good and Mitigate the Bad of Energy Water Nexus***

- **Reduce the energy-intensity of water**
- **Reduce the water-intensity of energy**
- **Make energy less vulnerable to water constraints**
- **Make water less vulnerable to energy constraints**
- **Solve cross-cutting problems (data, sensing, modeling, conservation...)**
- **Solve issues related to social, planning, policy, timescale, and spatial scales**



## ***Possible Solutions to Pursue***

- **Source Switching: Fuel & Water source switching**
- **Enhanced Technologies**
  - **Water/Energy lean technologies**
  - **Distributed energy/water technologies**
  - **Smart Technologies**
- **Cross-Sectoral Problem Solving**
  - **Using the water sector to solve energy problems**
  - **Using the energy sector to solve water problems**
- **Improve data and multi-user, -resource, -modeling**
- **Social, policy, market innovations**



# ***Source Switching Can Save Energy and Water***

- **Fuel Switching:** Use fuels that require less water
  - Less water intensive: natural gas, solar PV, wind
  - More water intensive: nuclear, coal
- **Water Source Switching:** use water sources that compete less with freshwater
  - Brackish, saline or reclaimed water for power plant cooling and oil/gas extraction
  - Reclaimed or greywater reuse for irrigation or cooling





# Despite Water Needs of Hydraulic Fracturing, Switching From Coal to NGCC Saves Water

## Pulverized Coal to Natural Gas Combined Cycle Water Savings

Source: Grubert, Beach, Webber (2012) • Graphic: Michael E. Webber, The University of Texas at Austin

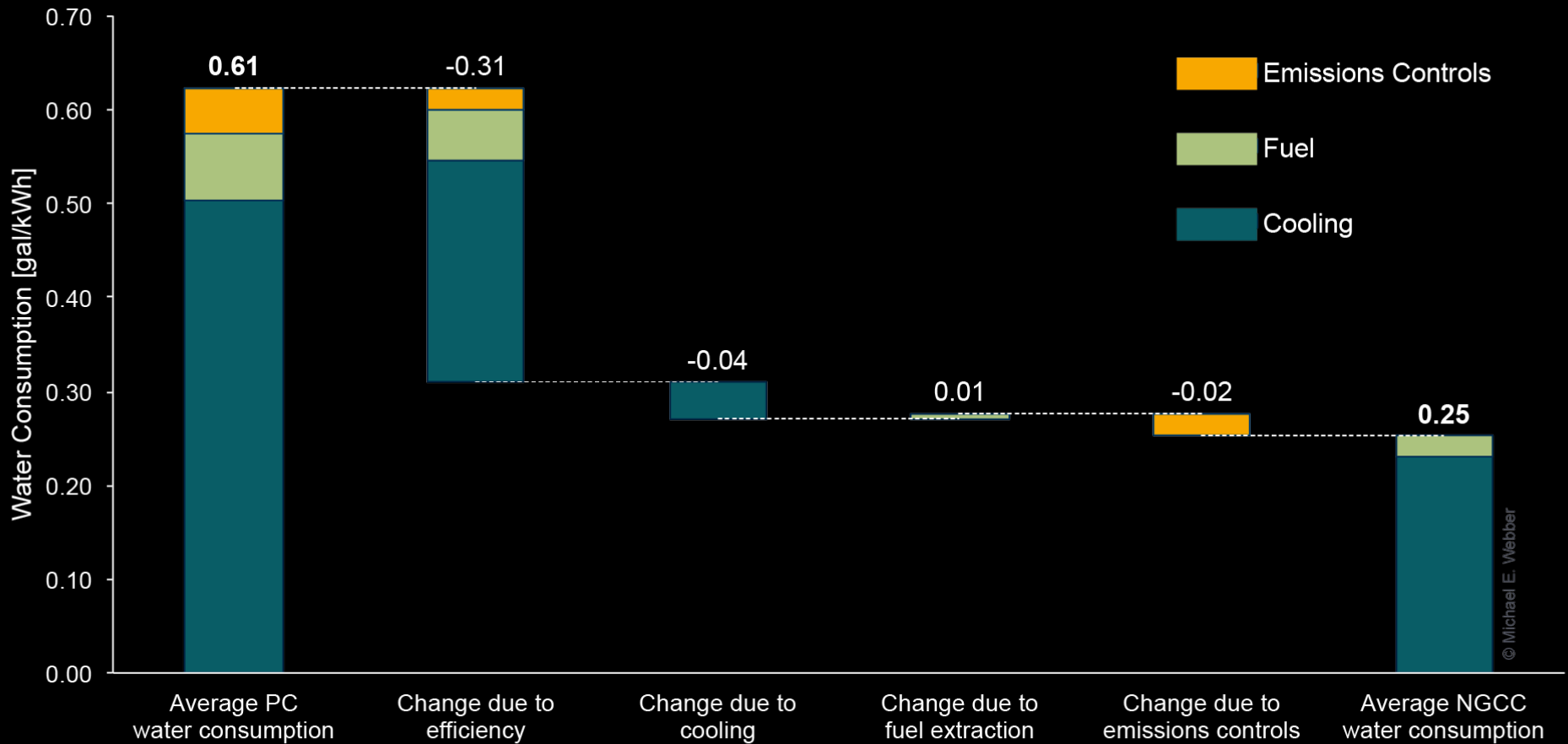

Texas Fleet Average

# *Enhanced Technologies Can Save Energy and Water*

- **Water lean energy technologies:** dry cooling at power plants, waterless fracking, low-water biofuels
- **Energy lean water technologies:** better membranes (with less fouling), using waste heat for water treatment, VFD pumps
- **Distributed energy and water technologies:** rooftop solar PV, microharvesters for energy, rain harvesters, on-site water treatment for oil and gas producers
- **Smart Technologies:** better meters and sensors for tracking uses and losses



# ***There Are Biological Approaches to Desalination***



- **Mangroves grow in seawater, producing freshwater with pressure-driven ultrafiltration**
  - “How Mangroves Desalinate Seawater,” *Physiologia plantarum* (1968)



Photo Credit: Wikipedia Commons

# *Water Systems Will Get Smarter*

- **Today's meters are dumb**
- **Need to know:**
  - **Use by sector**
  - **Use by time of day**
  - **Delivered vs. Used (e.g. leaks)**
  - **Use by function**
    - **Indoor vs. outdoor**
    - **Heated vs. unheated**
    - **Greywater vs. blackwater**
    - **Piped vs. collected**



# ***Cross-Sectoral Integration Holds Promise For Saving Energy and Water***

- **Using the water sector to solve energy problems**
- **Using the energy sector to solve water problems**



# *Power plants can use reclaimed water for cooling*

- Many thermoelectric power plants use non-fresh water for cooling
- In 2010, 46 U.S. power plants used reclaimed water for cooling
- Reclaimed water has advantages
  - Drought-resistant
  - Can be abundant
  - Can be safe
- Reclaimed water can pose operational challenges



Courtesy: Ashlynn Stillwell

Michael E. Webber, Ph.D.  
Energy Water Nexus  
June 10, 2013

# Power Plants Can Use Reclaimed Water for Cooling



Sand Hill Energy Center, Austin, TX  
Credit: Austin Energy

Palo Verde Nuclear Plant, Arizona  
Credit: Wiki Commons

# ***The Water Sector Can Be Used To Solve Energy Problems***

- ***Energy Recovery from WWTPs***
  - Use wastewater treatment to generate biogas
- ***Integrating Renewables with Water Treatment & Desal***
  - Abundant saline/brackish water
  - Abundant wind and solar radiation
    - 1000 hours of negative pricing in Texas because of abundant wind
  - Provide solutions to challenges of each technology
    - Water addresses intermittent, off-peak nature of wind
    - Wind addresses high marginal energy of desal/treatment





# Water Problems and Wind/Solar Resources Are Often Co-Located

[NRDC]

Water Supply Sustainability Index (2050)

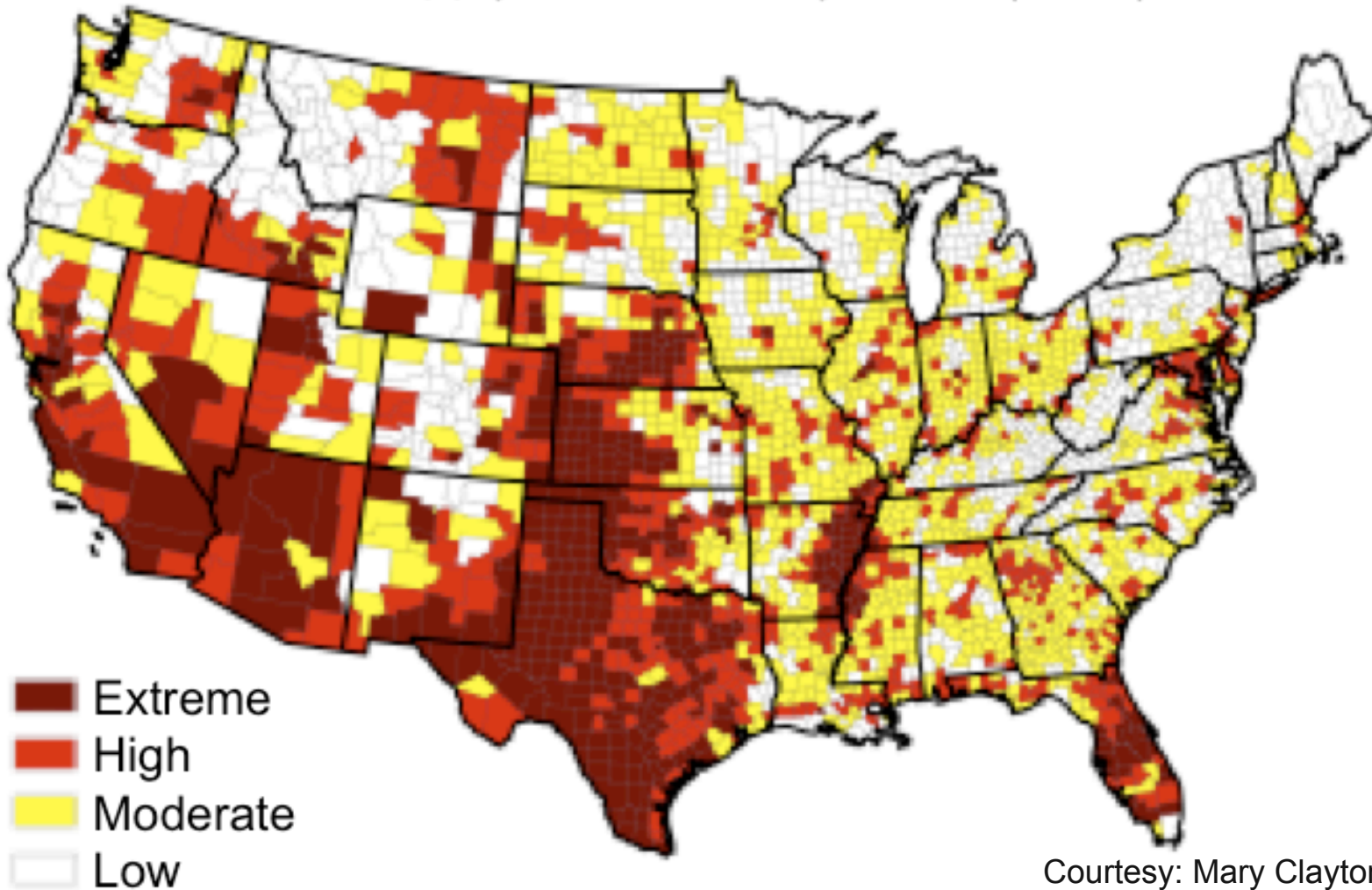

Courtesy: Mary Clayton

# ***Integrating Power Plants and Desalination Saves Energy***

- ***Powerplants can preheat water feedstream***
  - Increases throughput for membrane systems
  - Reduces energy for distillation systems
    - Example: Abu Dhabi's desal plant
- ***Saline/brackish water for cooling solar PV systems***
  - Improves PV performance
  - Preheats water for higher throughput
    - Example: El Paso, TX test systems



# *The Energy Sector Can Be Used To Solve Water Problems*

- *Dry- and/or hybrid cooling At Large-Scale Implementation*
  - Spares water for many other users
  - An economical approach for drought resiliency
- *Integrating Energy, Air Quality & Water For Dispatching*
- *Incorporating Water Into Grid Planning*
- *Energy Industry's Needs as a Driver for Water Efficiency*
  - Towards efficient water markets



# *The Oil & Gas Industry Could Become the Oil, Gas and Water Industry*

- *Daily liquids production:*
  - Oil extraction: 7 MMBD
  - Wastewater injection: 47 MMBD
    - 2 billion gallons per day (~2% of daily consumption)
- *Capturing Flared Gases for On-Site Water Treatment*
  - Up to 1/3 of gas production is flared (N. Dakota)
  - 3 wastewater streams: muds, flowback, produced
  - Flow rates decrease, TDS levels increase with time
  - Using flared gases for treatment via thermal distillation: reduces trucks, increases water supply, reduces flares, ...



# *There Are Also Non-Technical Challenges*



# *There Are Also Non-Technical Challenges*

- **Disaggregated policymaking**
- **Mismatched timescales**
- **Mismatched spatial scales**
- **Data problems**



# *Example of Disaggregated Energy and Water Policymaking In the USA*

- Funding and oversight mechanisms are separate
  - Energy planners assume they have the water they need
  - Water planners assume they have the energy they need
- Multitude of agencies, committees, etc. w/o clear authority
- Hierarchy of policymaking is dissimilar
  - Energy*: top-down
    - powerful federal energy agencies
  - Water*: bottom-up
    - powerful local water agencies



# ***Timescales Do Not Match for Energy and Water Policymaking***

- **Water**
  - Water plans are 50-100 years
    - Austin, TX debated a water plant for 40 years
  - Water data are backwards-looking
- **Energy**
  - Energy plans are 2-30 years
  - Energy data are backwards- and forward-looking





# ***Spatial Scales Do Not Match for Energy and Water Policymaking***

- **Water**

- **Natural: spans many cities and/or states**
- **Built:**
  - **Usually at the municipal scale**
  - **Some locations (CA, AZ,...) at the state scale**

- **Energy**

- **Electricity: continental via grid**
- **Oil/gas: continental via pipeline systems**
- **Coal: continental by train**
- **Biofuels: regional by truck**



# ***Water Data Are Sparse, Error-prone, and Inconsistent in the USA***

- **USGS data-collection is infrequent**
  - Last survey on water consumption: 1995
  - Last survey on water withdrawals: 2000 (2005)
- **Errors in national databases (Egrid, etc.)**
  - Differences between state and federal reporting
  - Unclear definitions:
    - Use vs. Withdrawal vs. Consumption vs. Diversion
  - Different units
    - **East:** gallons
    - **West:** acre-feet



# ***Solving the Data Problem: Invest Aggressively In Comprehensive Data Collection***

- **Government**
  - Water quantities in natural systems (NASA? USGS?)
  - Water quantities in energy systems (EIA?)
  - Energy quantities in water systems (EIA?)
  - Before and after water quality studies (EPA?)
- **Industry**
  - Need more data from industry for upstream AND downstream water uses AND powerplants
- **Academia/Innovators**
  - Better sensors, flow meters, remote sensing,...
  - Robust multi-resource modeling platforms



# *There Are Policy Solutions and Challenges*



# ***In 1961, President John F. Kennedy gave the USA two great technical challenges***



***May 1961***

***“No single space project in this period will be more impressive to mankind, or more important for the long-range exploration of space; and none will be so difficult or expensive to accomplish.”***

***April 1961***

***“If we could ever competitively—at a cheap rate—get fresh water from salt water, that would be in the long-range interest of humanity and would really dwarf any other scientific accomplishment.”***



*By 1969, we put a man on the moon*



Source: Web

Michael E. Webber, Ph.D.  
Energy Water Nexus  
June 10, 2013

***If We Spent As Much Effort and Money  
Looking for Water on Earth As We Do  
Looking for Water on the Moon and Mars,  
the Outcomes Might Be Very Different!***



# Energy R&D Is Drastically Underinvested

## Federal Nondefense R&D

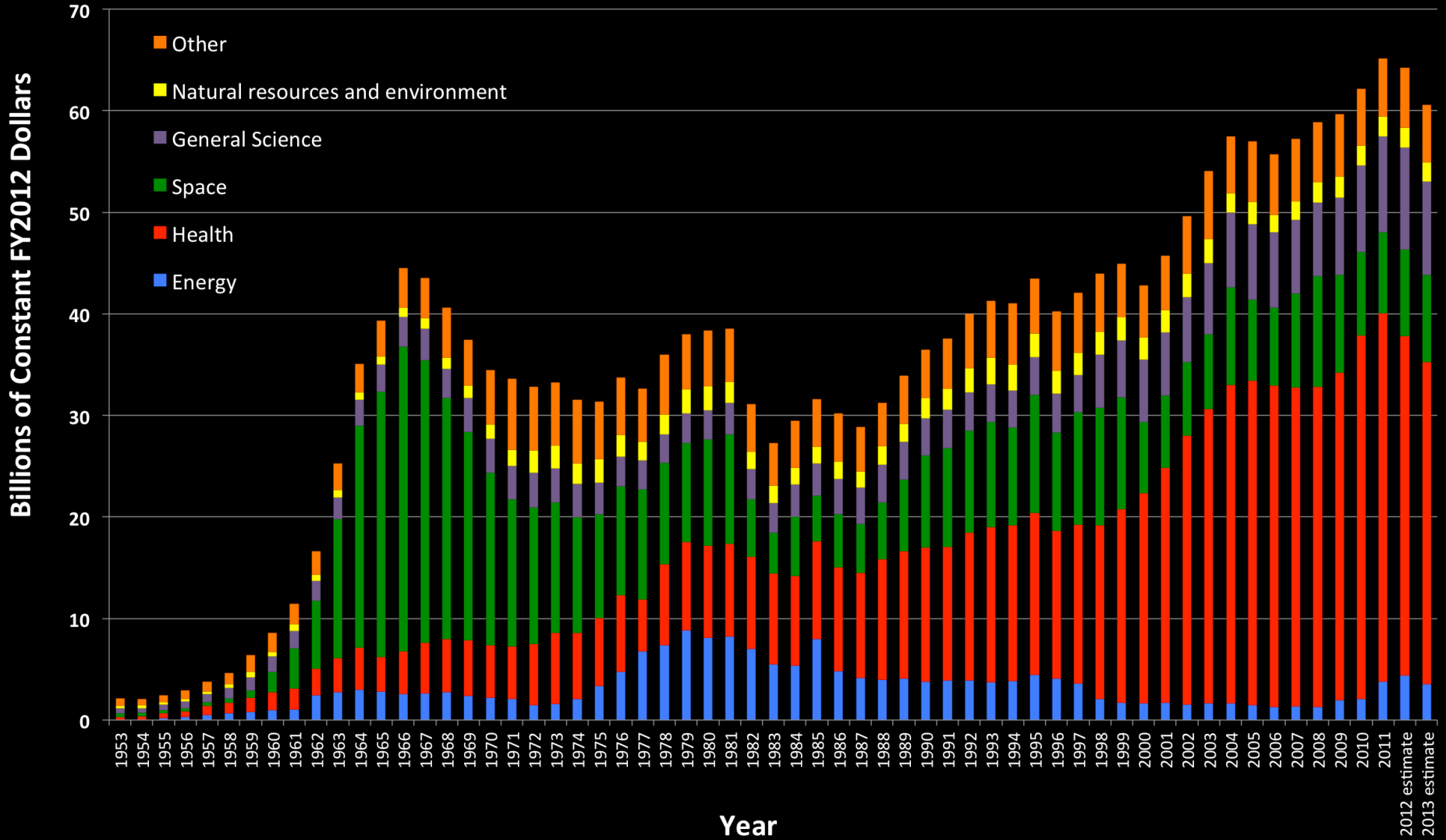

Source: AAAS



# Water R&D Is Even Lower

Available Data for Water R&D By Agency

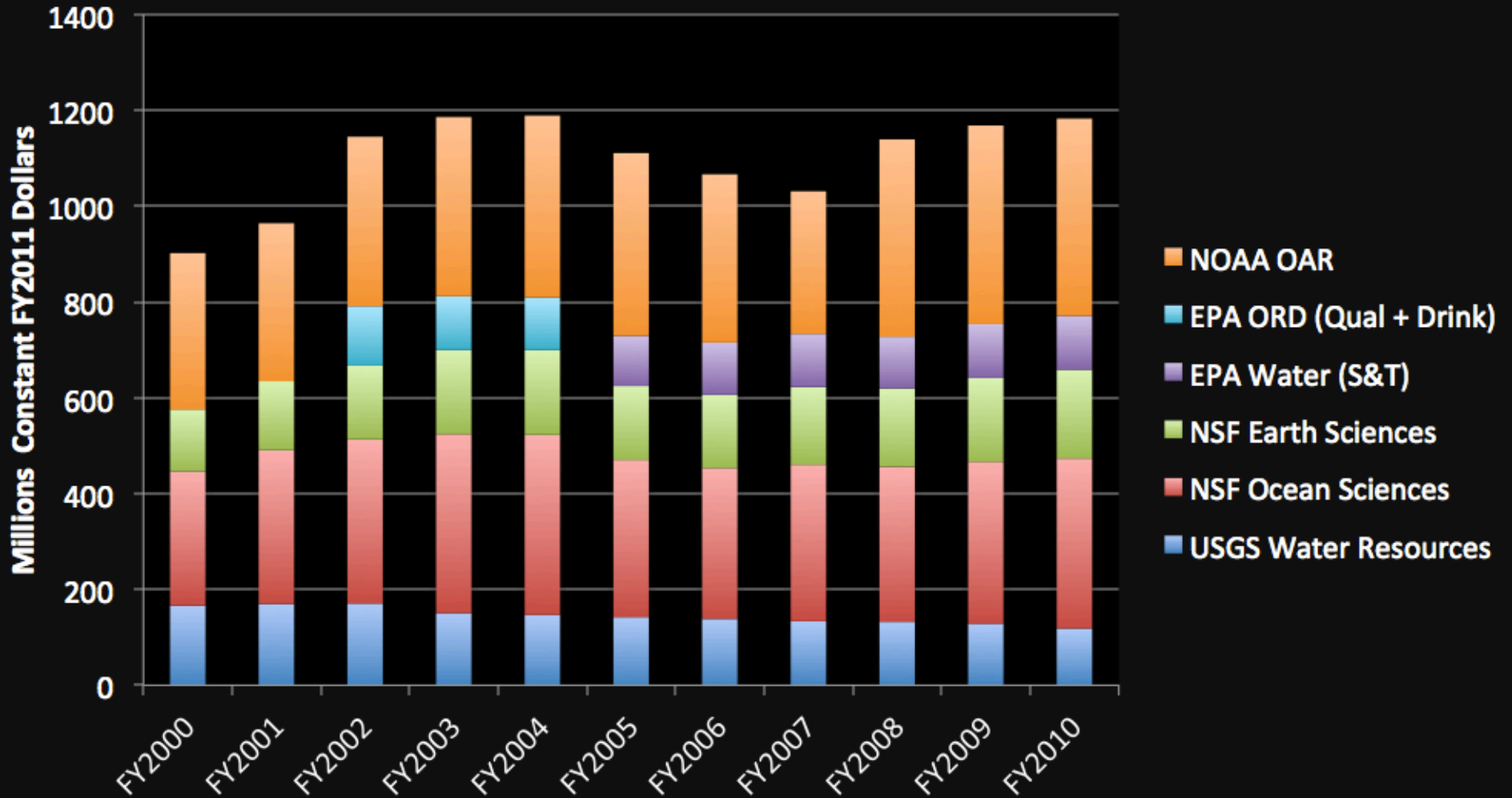

Source: Kirshenbaum & Webber, 2012

***There Is Justifiable Cause for A Healthy  
Dose of Realistic Pessimism That This  
Could Take A While***





***It's Not A Good Sign  
When We Have To  
Warn Ourselves Not  
To Drink Toilet  
Water***

Source: Stillwell

Michael E. Webber, Ph.D.  
Energy Water Nexus  
June 10, 2013

**52**

# ***Good news: energy conservation and water conservation are synonymous***

*“Turn off the water, Daddy. The scientists need time.”*  
– Evelyn Webber, 7 years old, March 2007

- **Conserving water will conserve energy**
- **Conserving energy will conserve water**



# Michael E. Webber, Ph.D.

*Deputy Director, Energy Institute*

*Associate Professor, Mechanical Engineering*

*Co-Director, Clean Energy Incubator*

webber@mail.utexas.edu

## Webber Energy Group



<http://www.webberenergygroup.com>

*completing the energy sustainability puzzle*



# **ENERGY** *and* **WATER**

## **Overview of Water Use for Electric Power Production**

**Mike Hightower**  
**Sandia National Laboratories**  
**NSF Workshop – June 10-11, 2013**

# Thermoelectric Power Generation Cooling Options



Once-Through Cooling

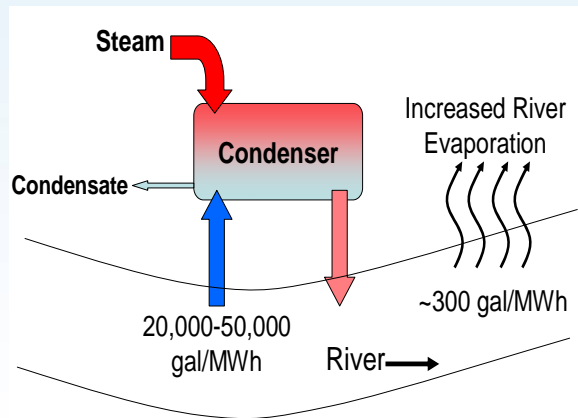

Closed-Loop (Evaporative) Cooling

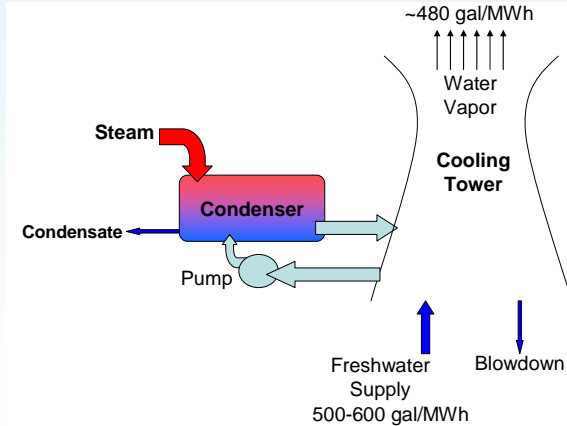

Dry-Cooled Power Plant

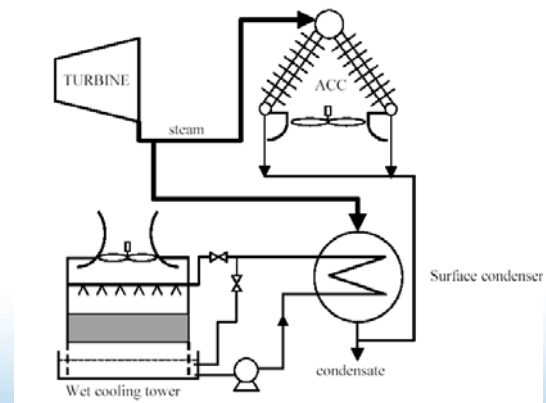

Hybrid Cooling

# 500 MW Coal Thermoelectric Power Plant - Steam Cycle

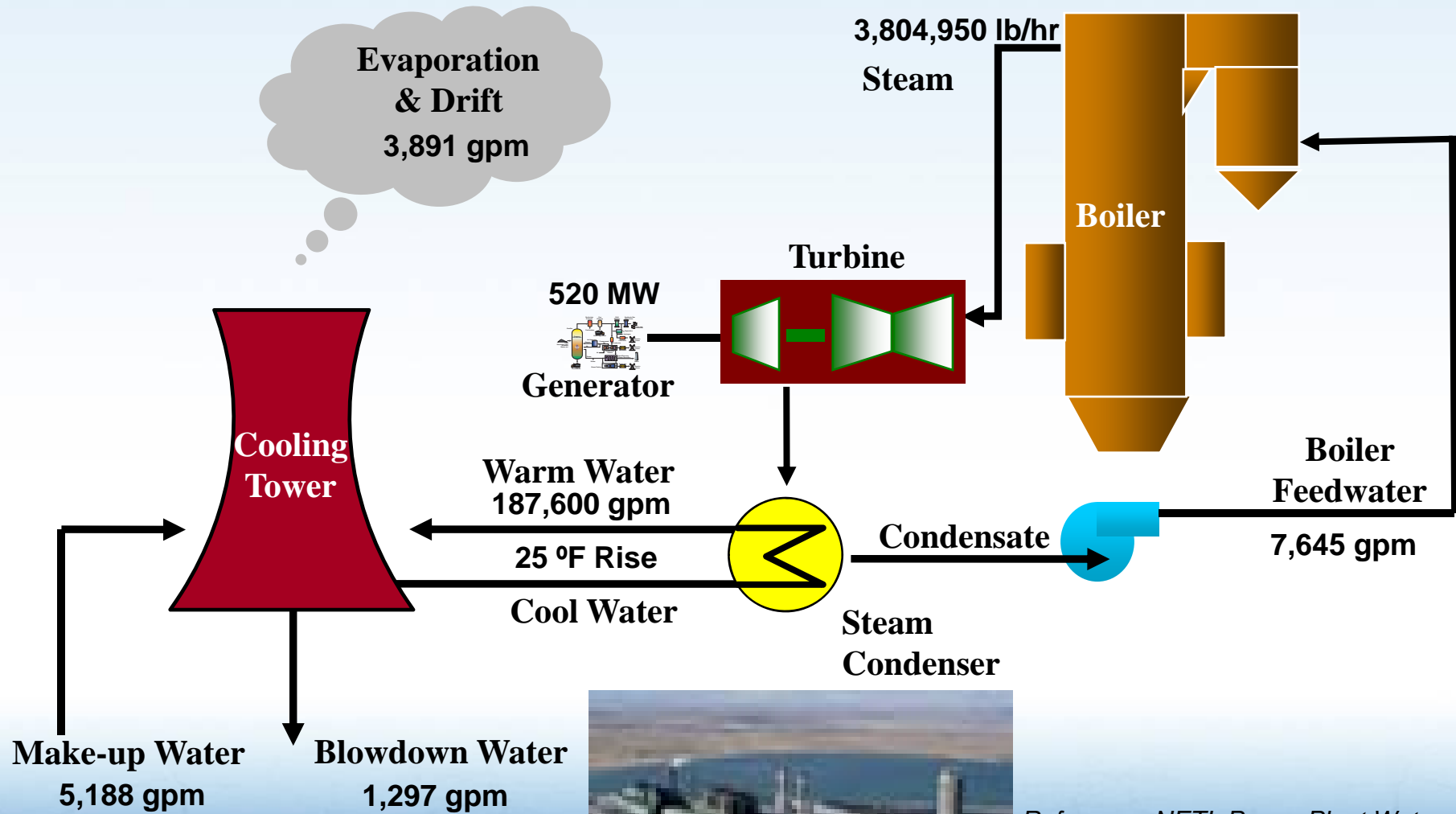

Reference: NETL Power Plant Water Consumption Study, May 2007



# Water Withdrawal Trends by Sector

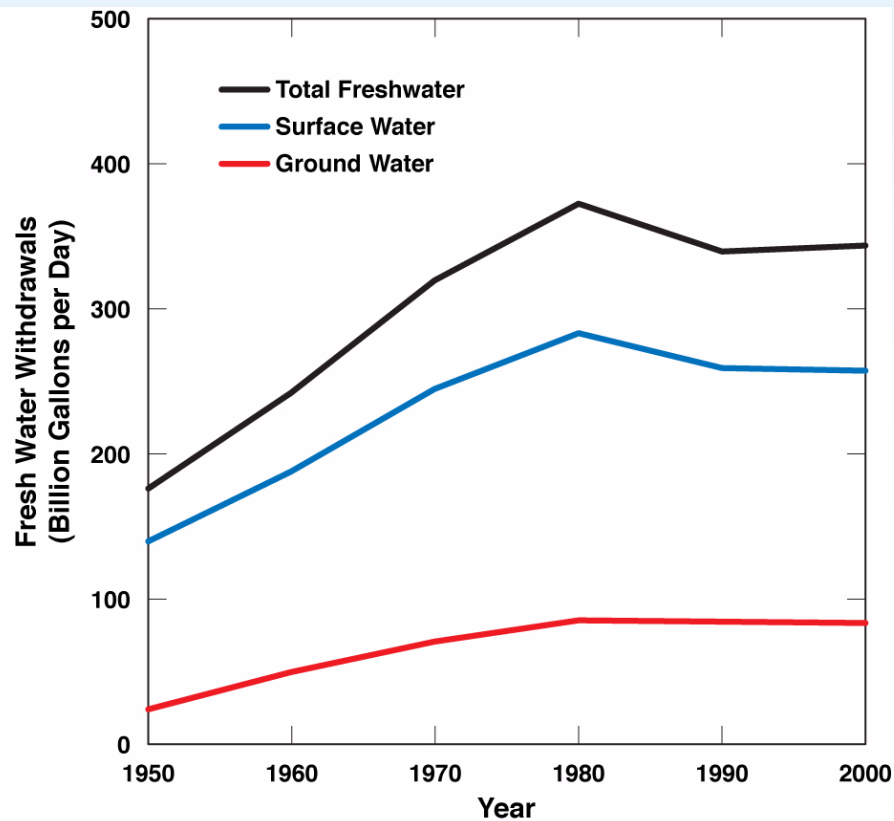
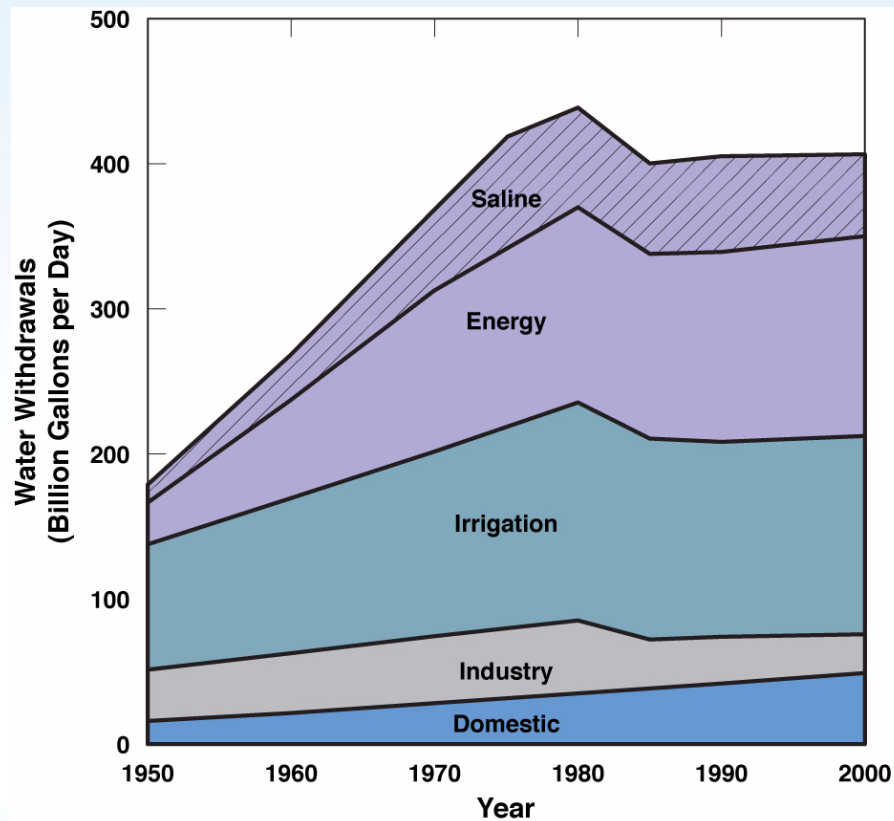

[USGS, 2004]

# Water Consumption by Sector



## U.S. Freshwater Consumption, 100 Bgal/day

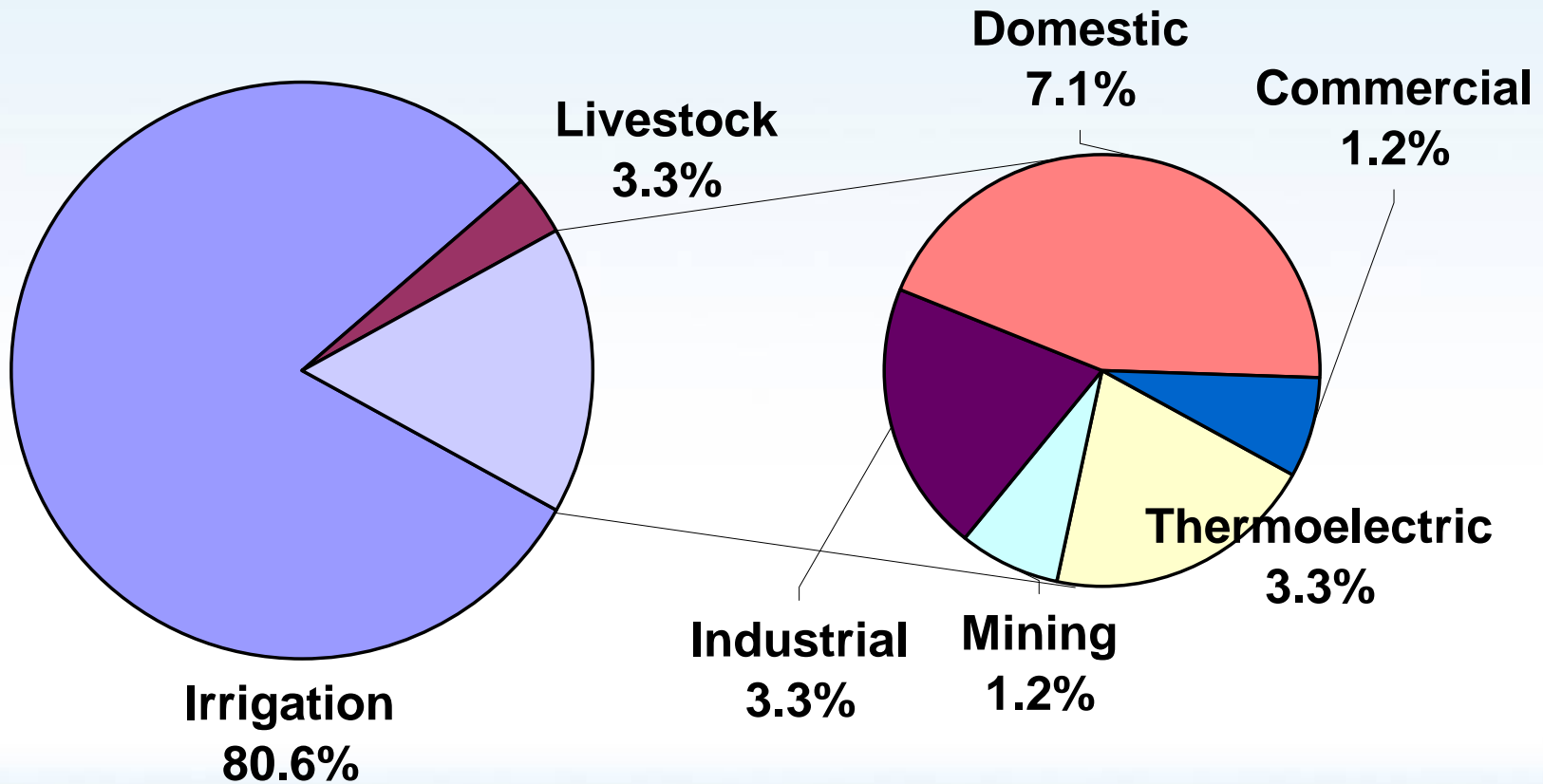

[USGS, 1998]



# Total Water W/D for Thermo Generation (mgd) Water Source for Thermo Generation: SW, GW, Saline (%)

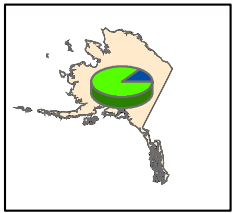
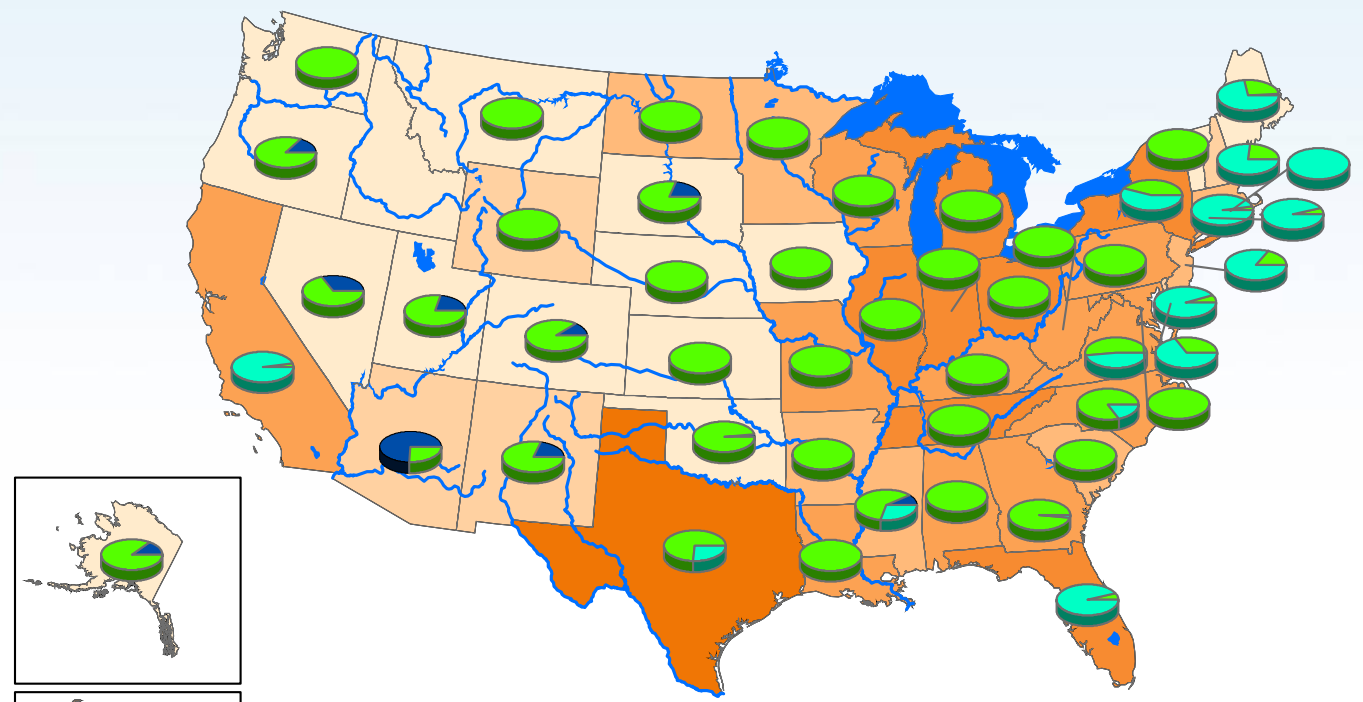

Sources:  
Water W/D: USGS 2000  
Source water: USGS 2000

# 4

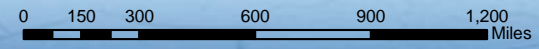

### Legend

- state rivers
- Major Lakes (National)

### states

### Water W/D (mgd)

- 0 - 165
- 166 - 787
- 788 - 2236
- 2237 - 6254
- 6255 - 10830
- 10831 - 17882

### source\_water

- GW
- SW
- Saline

# Electric Power Generation Water Withdrawal and Consumption



Plant-type	Cooling Process	Water Use Intensity (gal/MWh <sub>e</sub> )		
		Steam Condensing <sup>a</sup>		Other Uses <sup>b</sup>
		Withdrawal	Consumption	Consumption
Fossil/ biomass steam turbine <sup>c</sup>	Open-loop	20,000–50,000	~200-300	~30-90 <sup>d,i</sup>
	Closed-loop	300–600	300–480	
	Dry	0	0	
Nuclear steam turbine <sup>c</sup>	Open-loop	25,000–60,000	~400	~30 <sup>d</sup>
	Closed-loop	500–1,100	400–720	
	Dry	0	0	
Natural Gas Combined-Cycle <sup>c</sup>	Open-loop	7,500–20,000	100	10 <sup>e</sup>
	Closed-loop	~230	~180	
	Dry	0	0	
Coal Integrated Gasification Combined-Cycle <sup>c</sup>	Closed-loop	200	170	150 <sup>e,e</sup>
	Dry	0	0	150 <sup>e,e</sup>
Geothermal Steam <sup>f</sup>	Closed-loop	2000	700-1350	NA
Concentrating Solar <sup>g,h</sup>	Closed-loop	750	740	10
	Dry	10	0	10
Wind and Solar Photovoltaics <sup>j</sup>	N/A	0	0	1-2
<b>Carbon sequestration for fossil energy generation</b>				
Fossil or biomass <sup>k</sup>	All	~85% increase in water withdrawal and consumption		

# Concentrating Solar Power Technology



Steam Turbine Generator  
Dispatchable, Integrates with Storage



Trough

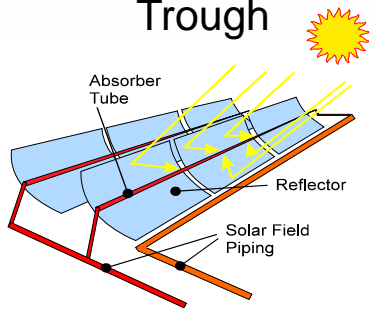

- Most cost effective >250MW
- Operating temp: 400C
- Annual efficiency: 14%

Stirling Engine-Alternator  
High Efficiency, no Storage



Towers

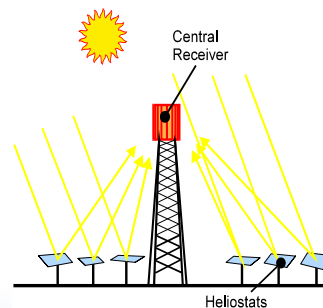

- Most cost effective >250 MW
- Operating temp: 560C
- Annual efficiency: 18%



Dishes

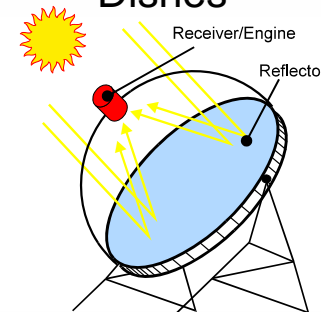

- Modular 30 kW units – more flexibility in siting
- Operating temp: 800C
- Annual efficiency: 23%

# Energy Growth/Technology Predictions will Impact Regional Water Demand Estimates



- Estimated most growth in water stressed regions
- Estimated low natural gas, low nuclear, low renewable use
- Estimated most new plants to use evaporative cooling

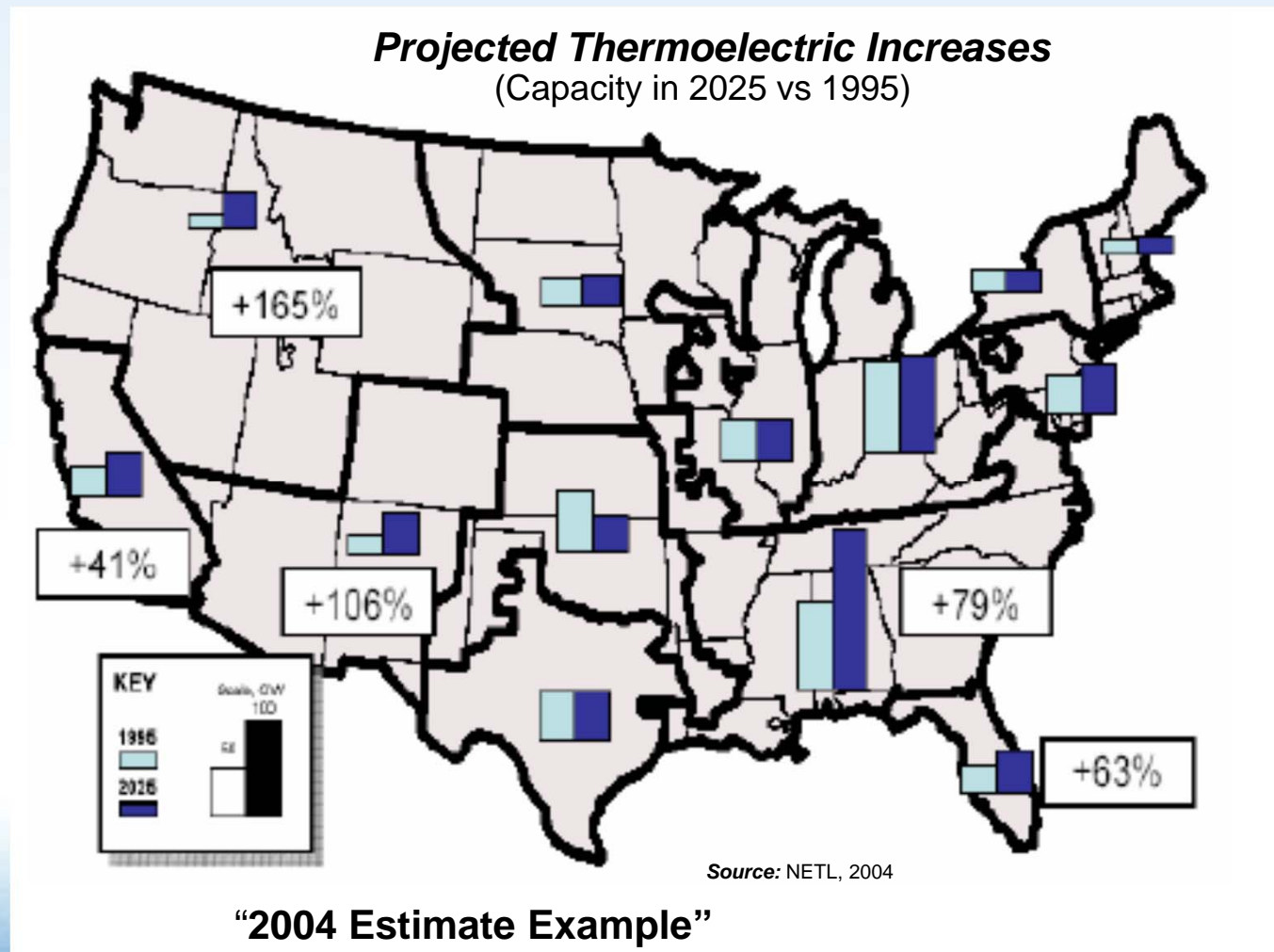

# Projected Generation Mix Impacts Estimated Water Demands in 2035 – 2007 Example



- Coal
  - 350, 400 MW steam turbine plants (140,000 MW)
- Natural Gas
  - 150, 100 MW natural gas combined cycle (15,000 MW)
- Renewables
  - 125, 200 MW wind or solar farms (25,000 MW)
- Nuclear
  - 5, 1000 MW nuclear reactors (5,000 MW)
- Hydroelectric
  - None (~40,000-60,000 MW available)

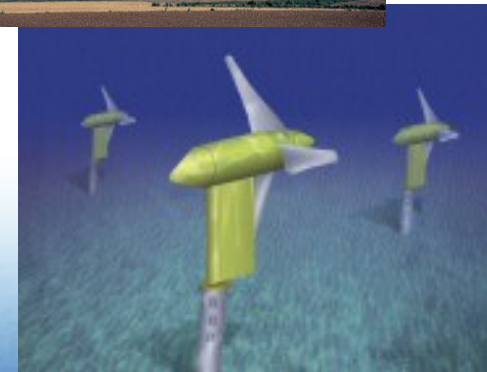

# Dry and Hybrid Cooling Issues and Opportunities



- 90% Less water consumption
- 6 % loss in production
- 20% reduced capacity at hottest hours
- 10% increase in capital cost
- 1-2 ¢ /kWh increase in cost of power

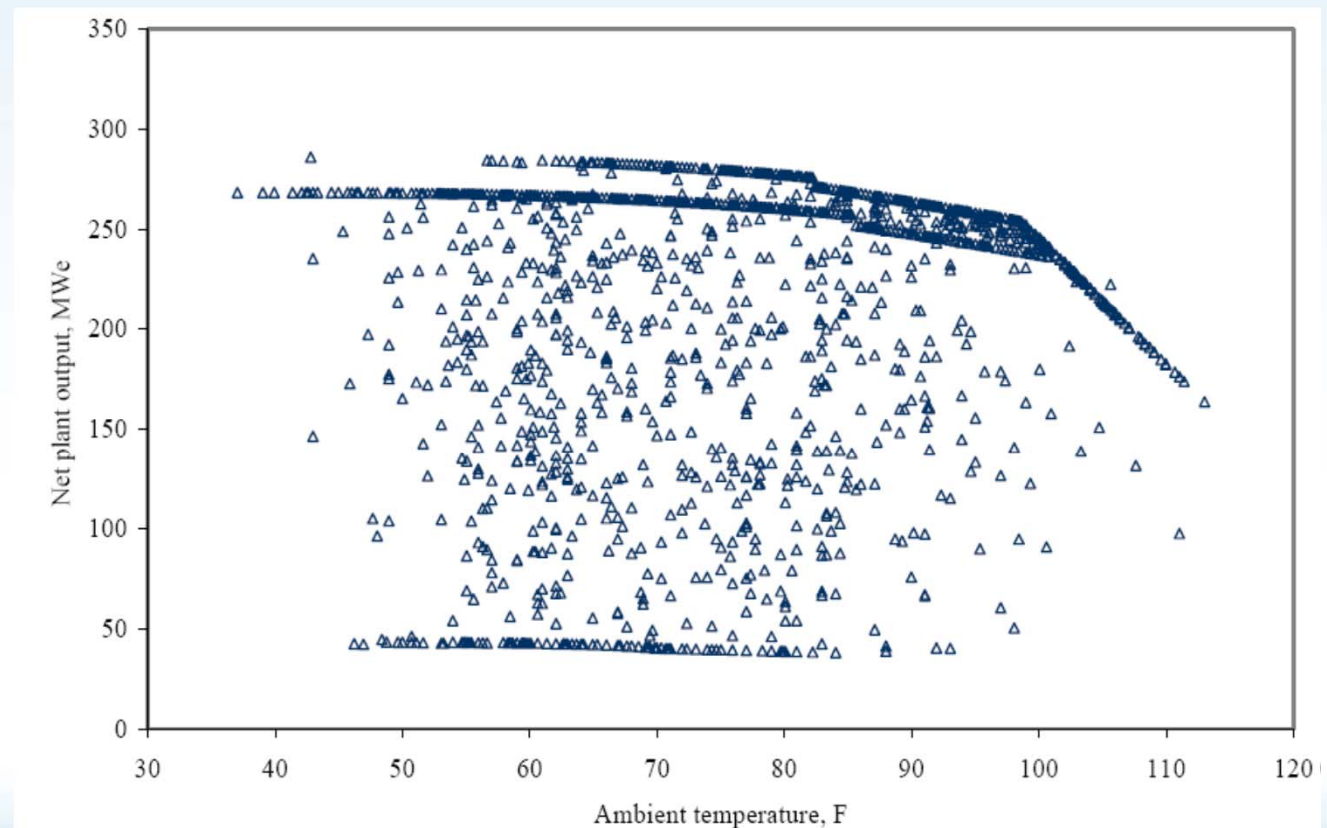

Figure 5 Net Plant Output as a Function of Ambient Temperature; Dry Heat Rejection



# Thermoelectric Power Plant Water Quality Requirements



- Power Plant Cooling Tower Systems
  - Do not require very good makeup water
    - Mine water, sea water, waste water
  - Can use recycled waters replacing fresh water
  - Many have converted to municipal wastewater
    - 50-60 using municipal or industrial waste water
  - Knowledge of cooling system design, construction and operation, recycled water quality, and improved water treatments make it successful and economical
  - Requires matching water quality with system
    - Chlorides, ammonia, phosphates, biological, corrosion foulants, scale
  - Has often saved water but not always costs
  - Drift of particulate is a growing issue





# Water and the Electric Power Sector

**Robert (Bog) Goldstein ([rogoldst@epri.com](mailto:rogoldst@epri.com))**  
Senior Technical Executive, Water and Ecosystems

**NSF Energy-Water Nexus Workshop**

Arlington, VA

June 10, 2013

# Co-Authors

- Richard Breckenridge  
([rbreckenridge@epri.com](mailto:rbreckenridge@epri.com))
- Sean Bushart  
([sbushart@epri.com](mailto:sbushart@epri.com))
- George Offen ([goffen@epri.com](mailto:goffen@epri.com))
- Jessica Shi ([jshi@epri.com](mailto:jshi@epri.com))
- Kent Zammit  
([kezammit@epri.com](mailto:kezammit@epri.com))



# EPRI R&D Strategy

## Water Resource Management

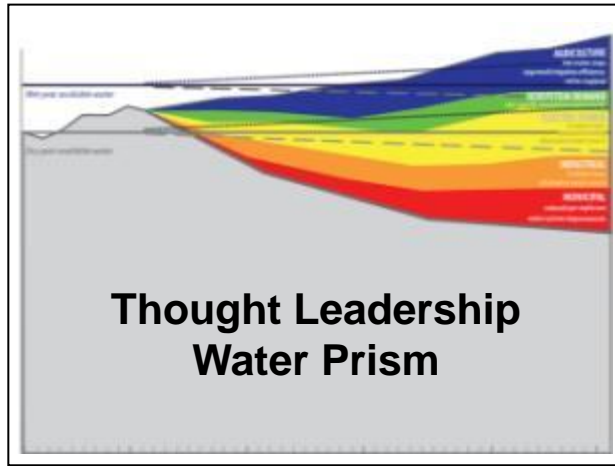

**A Cross Sector EPRI R&D Team Executing the Water R&D Strategy**

# Approaches to Reaching Sustainability

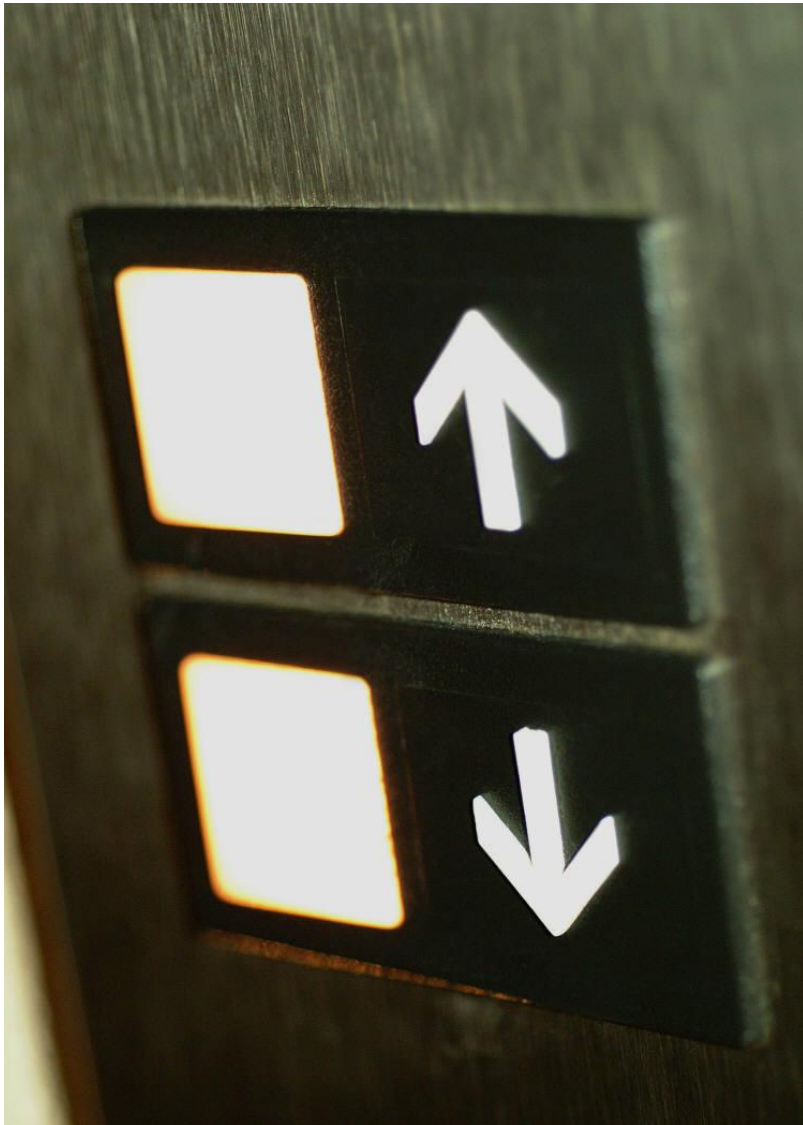

- Top down
  - Community/region/watershed-based
  - Considers all stakeholder demands
  - Matches aggregate water demands to supply
- Bottom up
  - Sector/Facility-based
  - Objectives
    - Increase water use efficiency
    - Conservation

# Thermoelectric Power Plant Strategies to Reduce Freshwater Demand

- Advanced cooling technologies
- Recycled water within plant
- Degraded/reclaimed/non-traditional water sources
- Increased thermal energy conversion efficiency



# Water Use Efficiency

## (Thermoelectric Plants Using Wet Cooling Tower)

Water Use by Plant Type

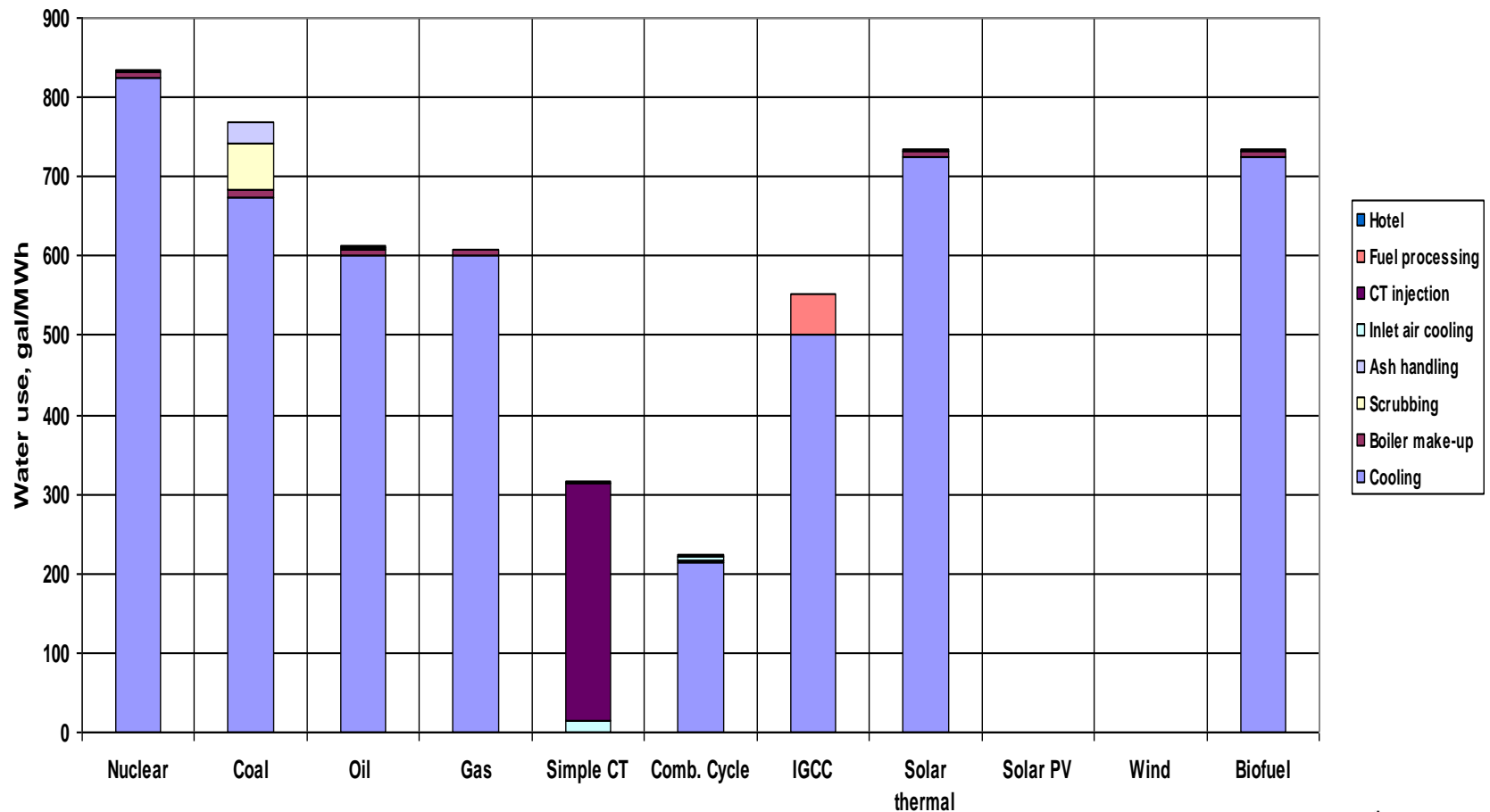

# Sustainability: Total Freshwater Withdrawal (2005)/Average Available Precipitation (1934-2005)

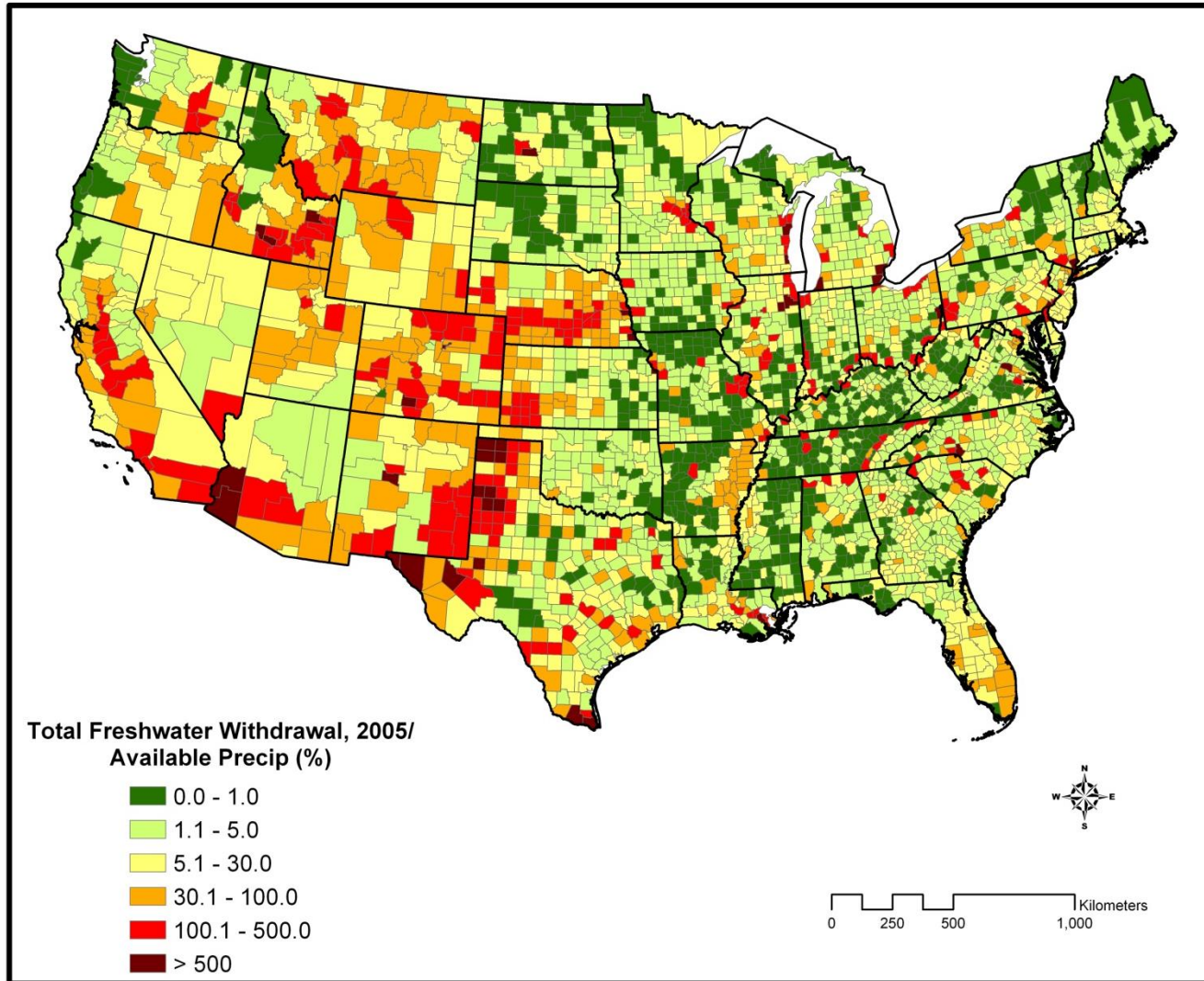



# National Freshwater Withdrawals by Year

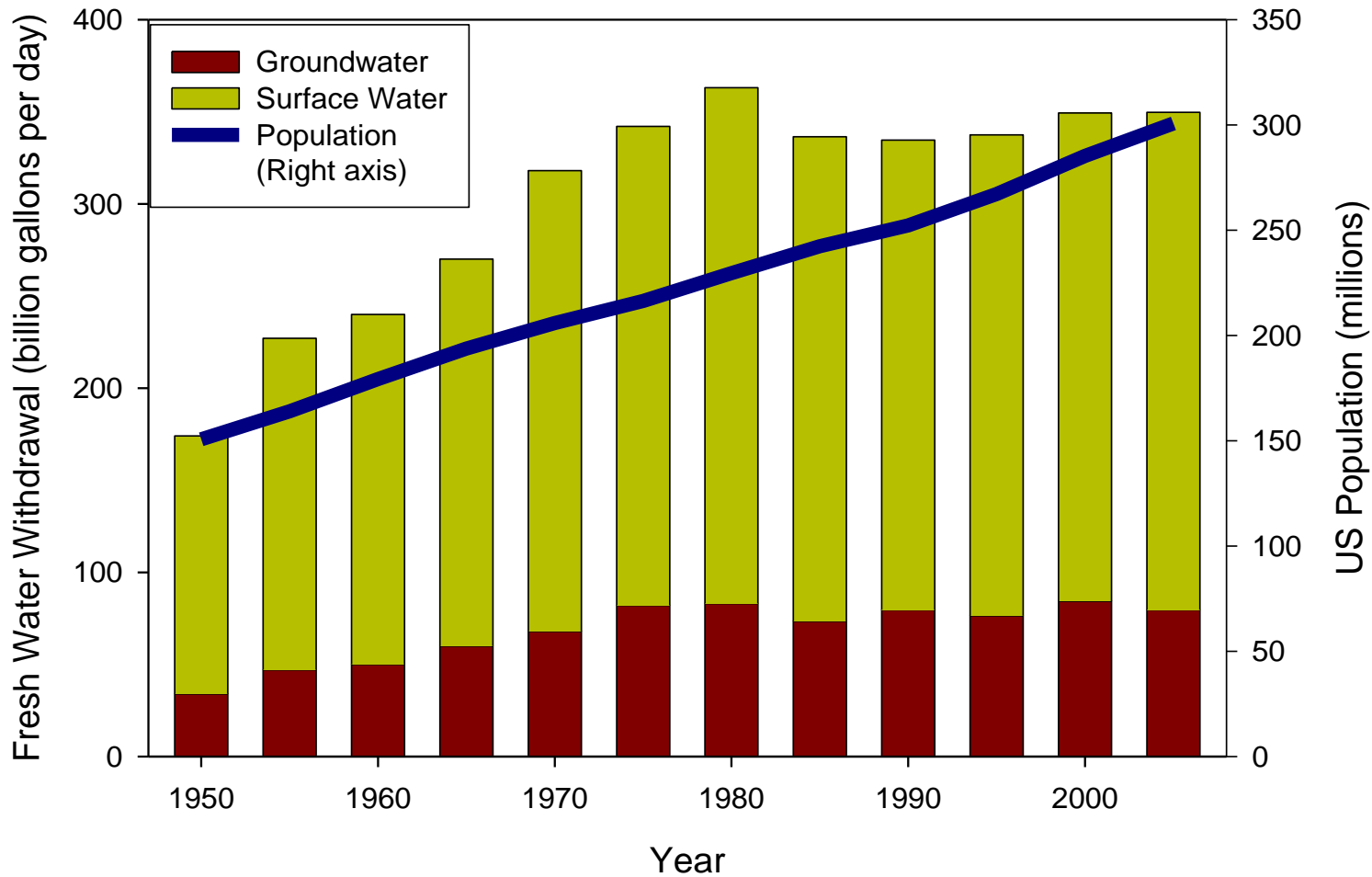

# Change in Freshwater Withdrawal 2005-1985

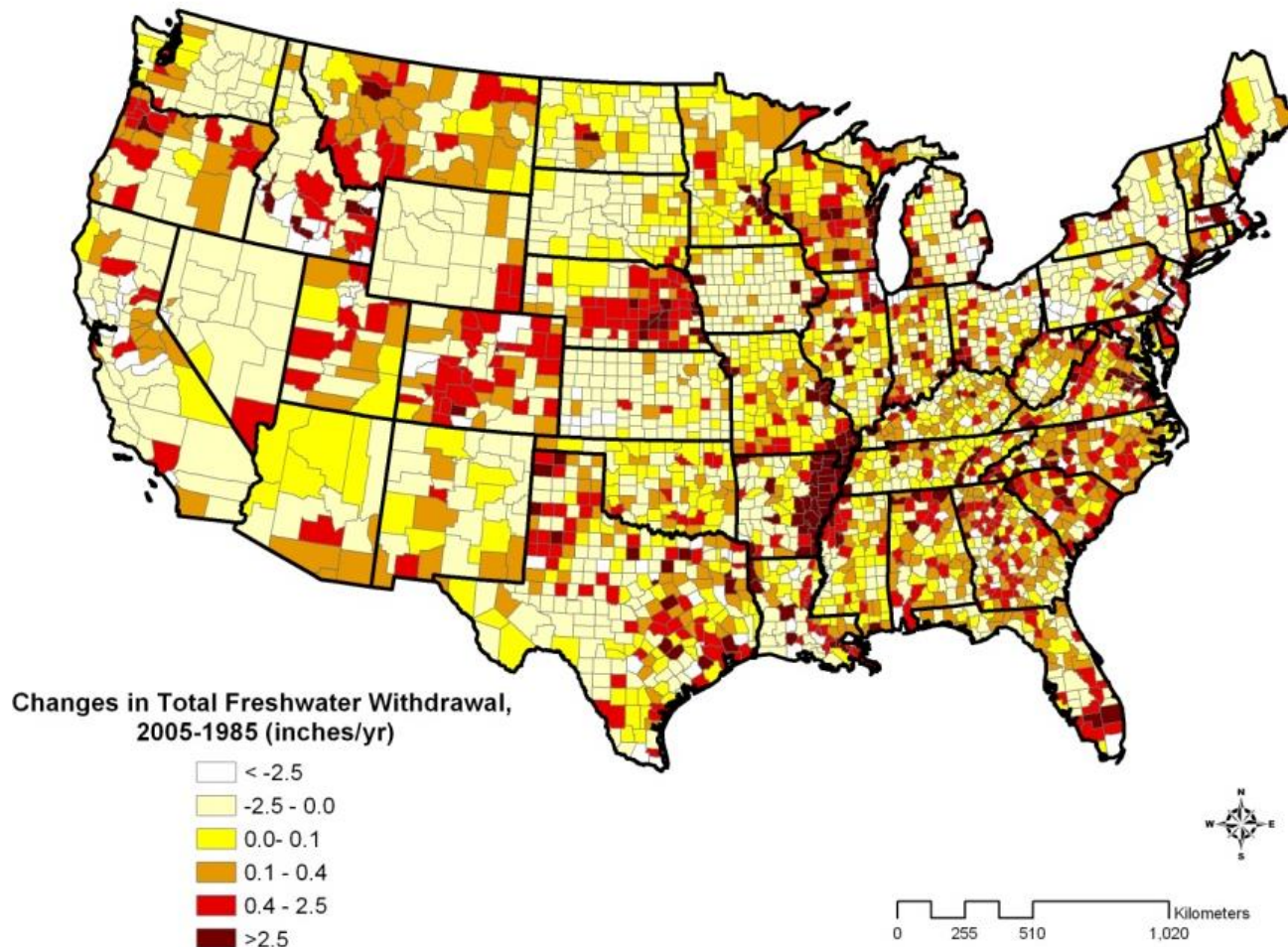

# Trend in Thermoelectric Water Withdrawals

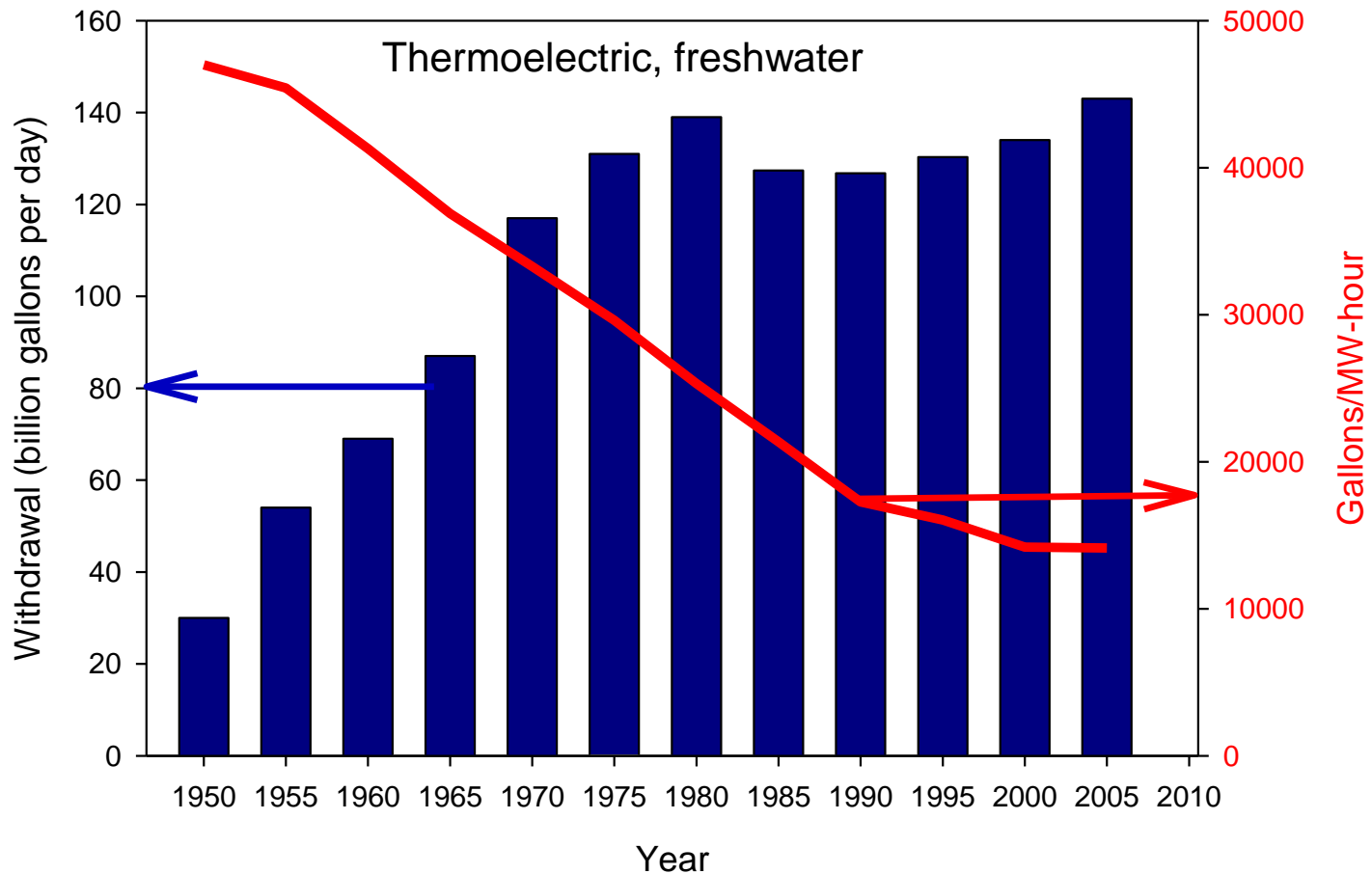

# Water Prism: Conceptual Design

- Compute system water balance on regional scale
  - Available surface water informed by a watershed model
  - Include groundwater sources and uses
- Project consumptive demand for 40 to 50 year horizon
- Explore water saving strategies through scenario analysis
- Give it the “feel” of EPRI’s CO<sub>2</sub> Prism – graphical displays

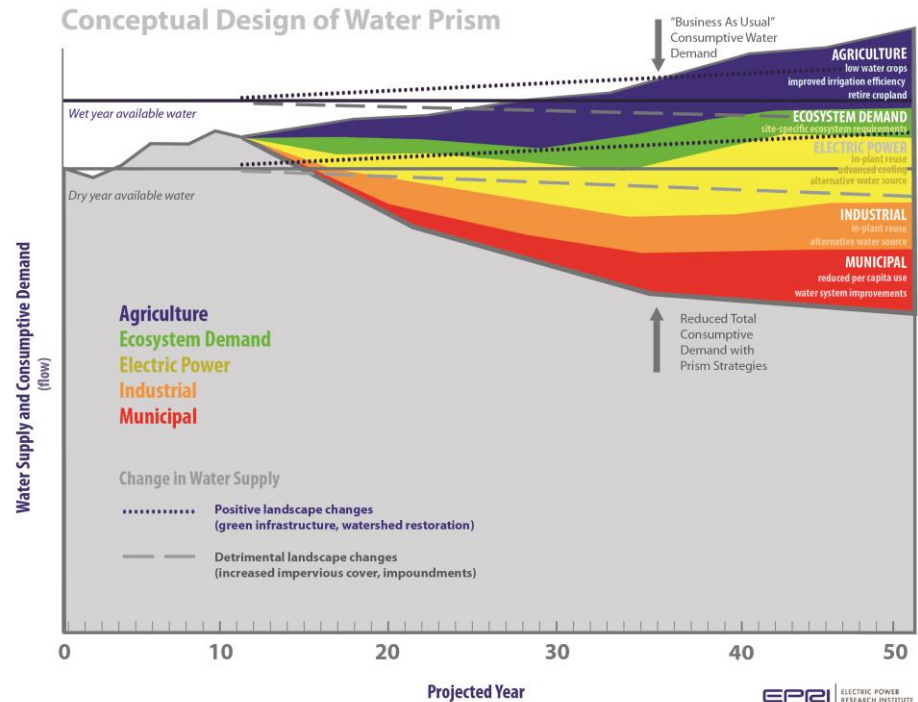

**Examine various scenarios to consider water use reductions needed to keep “demand” below “supply”**

# Water Use for Electric Power Generation

- EPRI Report 1014026 ([www.epri.com](http://www.epri.com))
- Overview of water requirements
- Conventional wet cooling
- Water recovery, recycling and reuse
- Dry cooling technology
- Alternatives to freshwater supply
- Economics of water
- Case studies of different plants operating in various regions of the U.S.

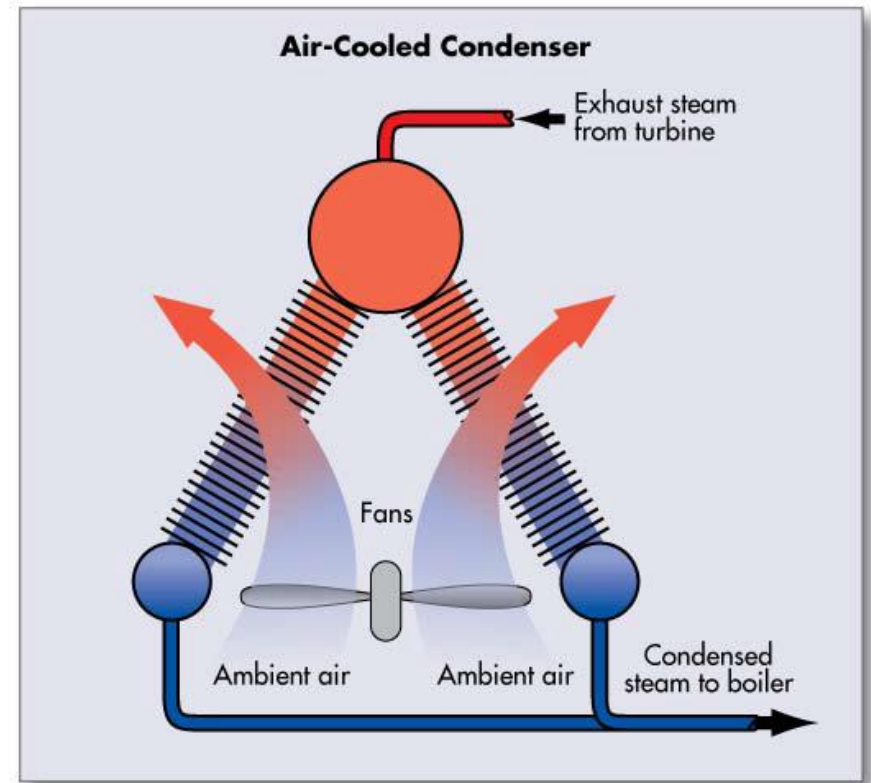



# EPRI Water Innovation Program: Progress Summary

## Progress Since 2011 Program Initialization

- Received 114 proposals from Request for Information Solicitations.
- Funded 11 projects, including three *exploratory* type projects
- Published ten reports and briefs  
(<http://www.epri.com/abstracts/Pages/ProductAbstract.aspx?ProductId=000000000001025771&Mode=download&Mode=download>)
- Filed one patent application
- Co-hosted joint workshop and released **2013 joint solicitation with the National Science Foundation.**

# Waste Heat Driven Green Adsorption Chillers for Steam Condensation (Collaboration with Allcomp)

Schematic Illustration of a Typical Adsorption Chiller

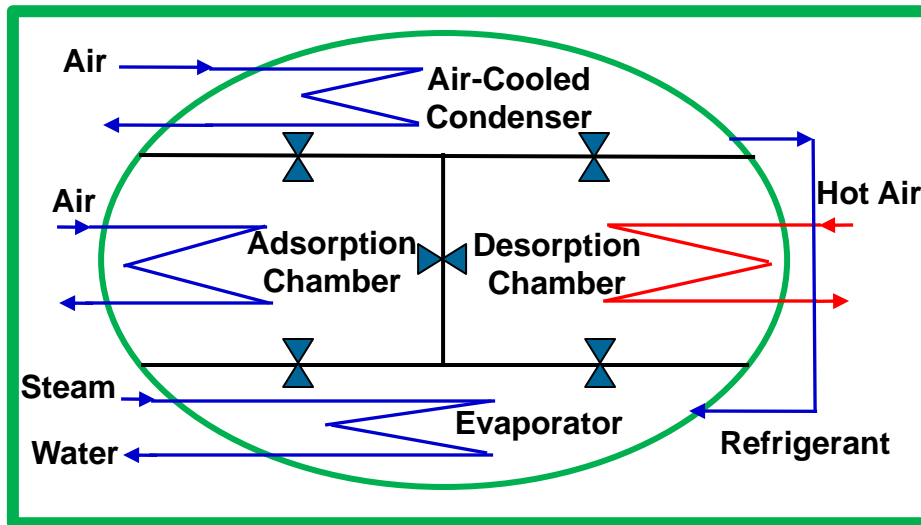

## Key Potential Benefits

- Dry cooling system
  - **Near Zero** water use and consumption
- Reduced condensation temperature
  - As low as **35 °C**
  - Potential for annual power production increase by up to 5%
- Full power production even on the hottest days compared to air cooled condensers.

## Phase 1 Project Update (EPRI Patent Pending)

- Developed several power plant system level approaches to utilize waste heat or solar heat for desorption
- Performed system integration energy and mass flow balance analysis for a 500 MW coal-fired power plant
- Performed technical and economic feasibility study
- Finalizing final report.



# Thermosyphon Cooler Technology (Collaboration with Johnson Controls)

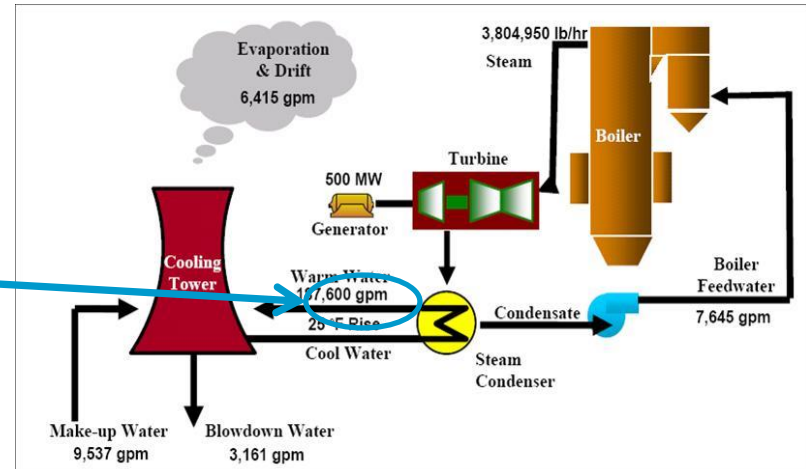
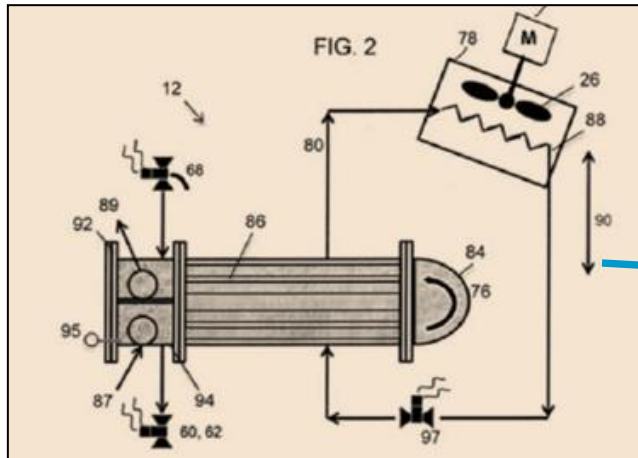

## Project Update

- Performed a thorough feasibility evaluation of a hybrid, wet/dry heat rejection system comprising recently developed, patent pending, thermosyphon coolers (TSC).
- Made comparisons in multiple climatic locations, to standard cooling tower systems, all dry systems using ACC's, hybrid systems using parallel ACC's, and air coolers replacing the thermosyphon coolers.
- Determined the most effective means to configure and apply the thermosyphon coolers.
- Completed final project review on March 5<sup>th</sup>.

## Key Potential Benefits

- Potential annual water savings up to 75%
- Compared to ACC, full plant output is available on the hottest days
- Ease of retrofitting
- No increase in surface area exposed to primary steam
- Reduced operating concerns in sub freezing weather
- Broad application for both new and existing cooling systems for fossil and nuclear plants)

# Thermosyphon

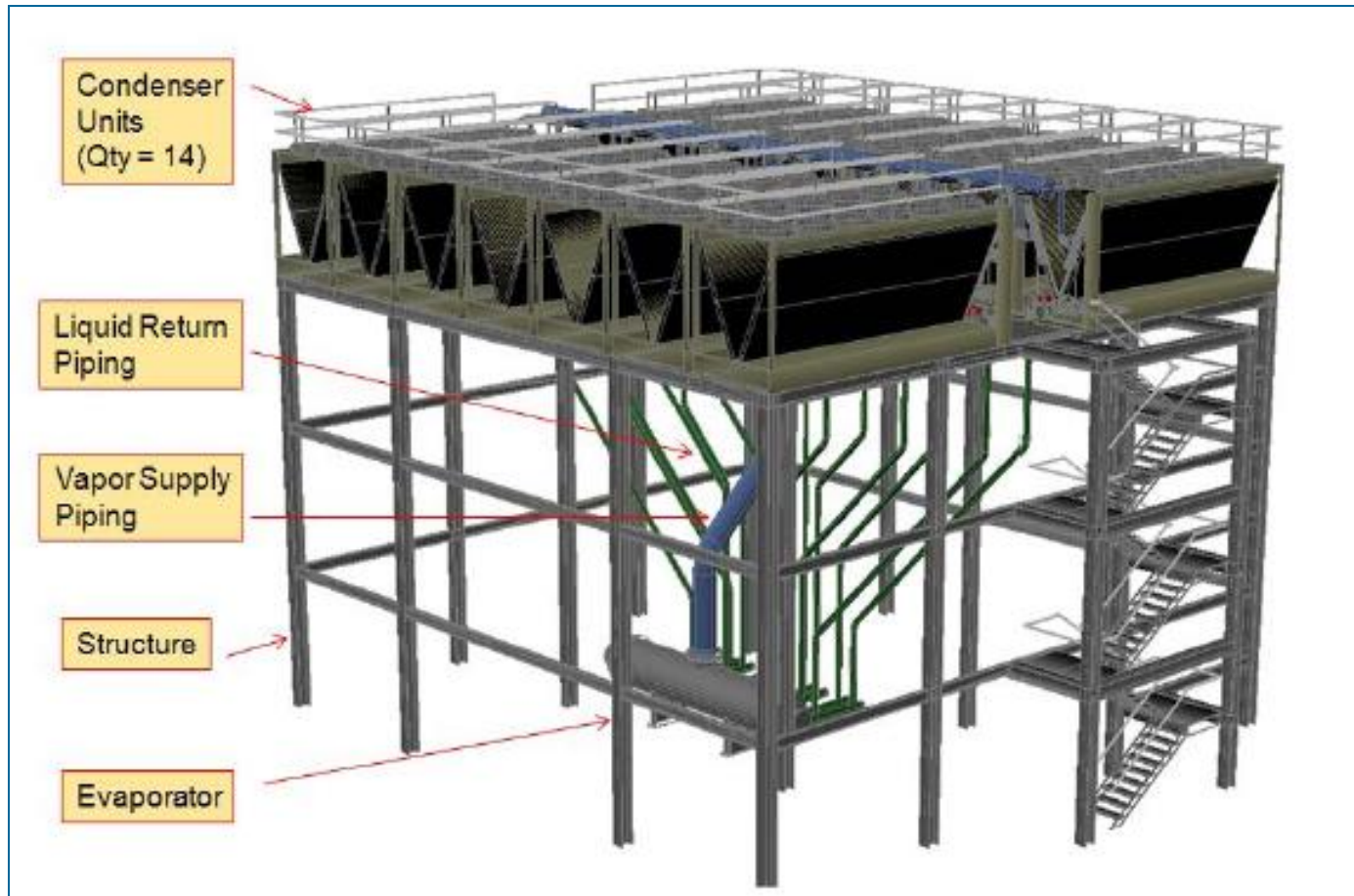

# Advanced M-Cycle Dew Point Cooling Tower Fill (Collaboration with Gas Technology Institute)

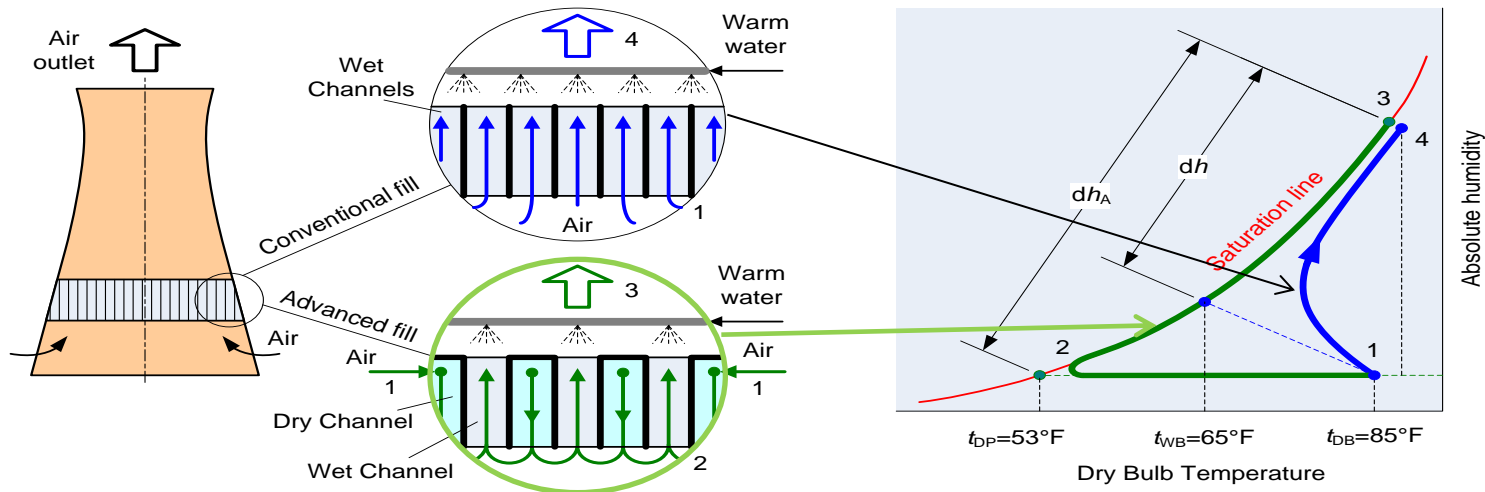

## Project Scope

- Develop an advanced fill
- Perform CFD and other types of energy, mass, and momentum balance modeling
- Evaluate performance and annual water savings for several typical climates using simulation models
- Perform testing in lab
- Perform technical and economic feasibility evaluation

## Key Potential Benefits

- Potential for less cooling water consumption by up to 20%
- Lower cooling tower exit water temperature resulting in increased power production
- Ease of retrofitting
- Broad applications

# Heat Absorption Nanoparticles in Coolant (Collaboration with Argonne National Laboratory)

## Project Scope

- Develop multi-functional nanoparticles with ceramic shells and phase change material cores
- Measure nano-fluid thermo-physical properties
- Perform testing in lab
- Assess potential environmental impacts due to nanoparticle loss to ambient air and water source.
- Perform technical and economic feasibility evaluation

Phase Change Material (PCM) Core/Ceramic Shell  
Nano-particles added into the coolant.

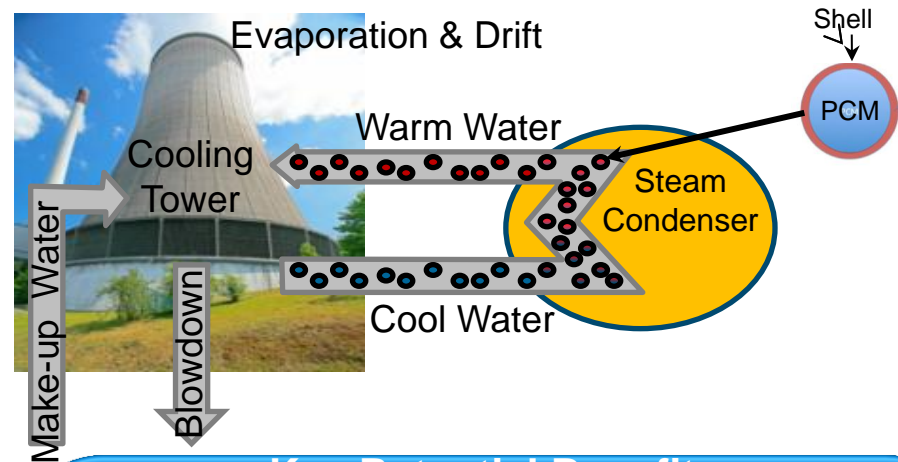

## Key Potential Benefits

- Up to 20% less evaporative loss potential
- Less drift loss
- Enhanced thermo-physical properties of coolant (e.g., latent heat, specific heat capacity)
- Inexpensive materials
- Ease of retrofitting
- Broad applications (hybrid/new/existing cooling systems)

# Water Research Center (Plant Bowen, Euharlee, GA)



# Concluding Thoughts

- There is no such thing as Business as Usual - everything is evolving with time
- Everything is geographically distributed non-uniformly
- Top down management is necessary for sustainability
- Need localized, fine resolution decision support tool to manage community (watershed, region) water resources
- Strategic and technological approaches depend on location
- Research can lead to promising breakthrough technologies to save water

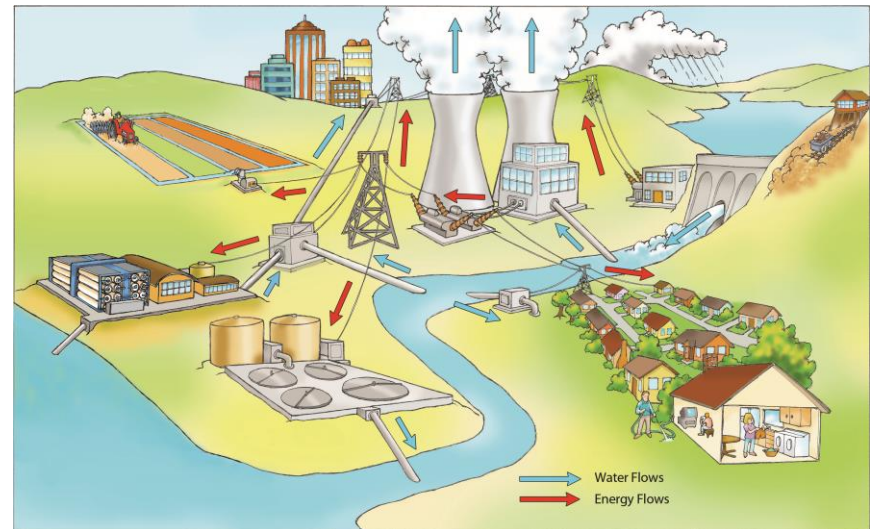

# Water for Biofuels: Implications for Energy, Food and Environment

Ximing Cai

Ven Te Chow Hydrosystems Laboratory  
Department of Civil and Environ. Engineering  
University of Illinois at Urbana-Champaign  
xmcai@illinois.edu

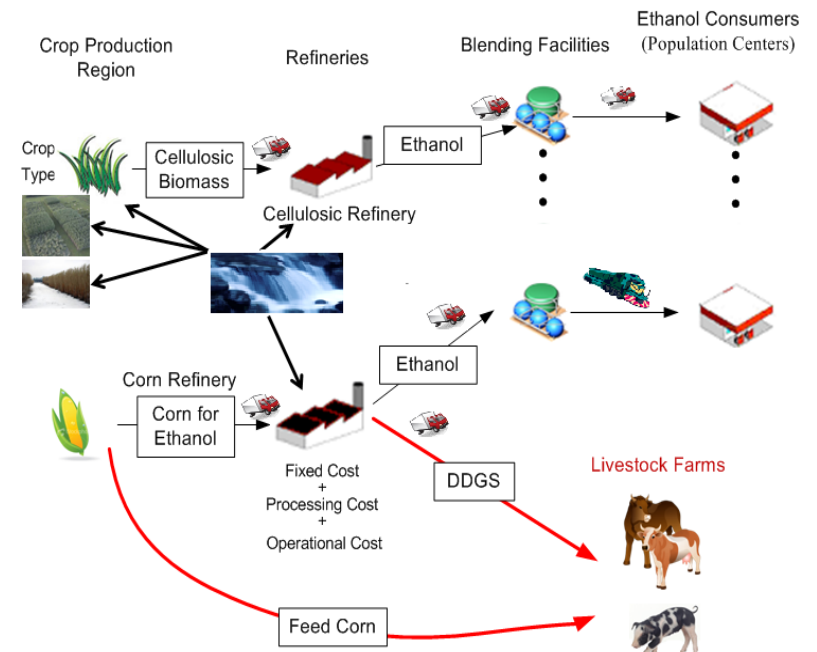

# Water for Biofuels

- Background
- Issues
- Outlook for research



# Background of Biofuels

- Renewable energy and cleaner energy than gasoline
- New opportunity for agriculture and economic development
- 1<sup>st</sup> and 2<sup>nd</sup> generation of biofuel crops
  - 1<sup>st</sup>: Corn, corn stover, sugarcane
  - 2<sup>nd</sup>: Cellulosic crops, e.g., Miscanthus, switchgrass



# Corn-based Ethanol Increased Corn Production

Sunday, August 12, 2007

Page 41

## MARKETPLACE

Tim Landis,  
business editor: 788-1536  
tim.landis@sj-r.com

THE STATE JOURNAL-REGISTER • SPRINGFIELD, ILLINOIS

# Ethanol powers farmland market

*Some worry that  
producers just  
starting will get  
priced out*

By **MONICA DAVEY**

N.Y. TIMES NEWS SERVICE

DEKALB — While much of the nation worries about a slumping real estate market, people in Midwestern farm country are experiencing exactly the opposite. Take, for instance, the farm here — nearly 80 acres of corn and soybeans off a gravel road in a universe of corn and soybeans — that sold for \$10,000 an acre at auction this spring, a price that astonished even the auctioneer.

"If they had seen that day, they would have never believed it," Penny Layman

said of her sister and brother-in-law, who paid \$32,000 for the entire spread in 1962 and whose deaths led to the sale.

Skyrocketing farmland prices, particularly in states such as Illinois, Iowa and Nebraska, giddy with the promise of corn-based ethanol, are stirring new optimism among established farmers. But for younger farmers, already rare in this graying profession, and for small farmers with dreams of expanding and grabbing a piece of the ethanol craze, the news is oddly grim. The higher prices feel out of reach.

"It's extremely frustrating," said Paul Burrs, who farms about 400 acres near

Dixon and says he regularly bids on new farmland in the hopes of renting it. Mostly, he said, he loses out to higher bidders.

"I crunch  
can. But  
more I car  
Burrs, v  
a stepgran  
it's in my l  
you've got  
this." Still  
make it a

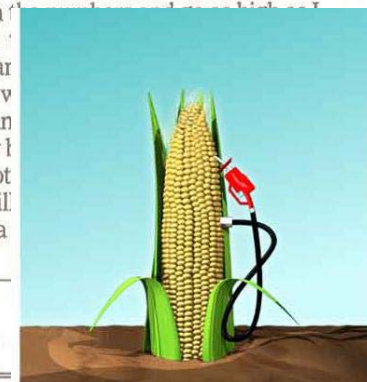

# Corn-based Ethanol Increased Corn Production



## U.S. Corn Yield

Bushels/Acre

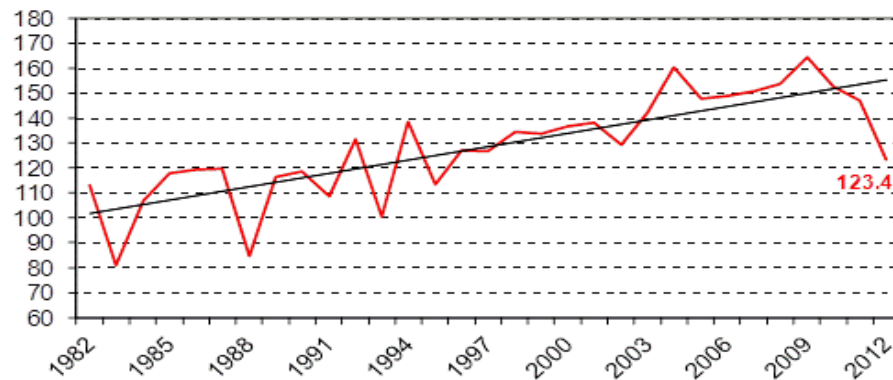

USDA-NASS  
01-11-13



## U.S. Corn Production

Billion Bushels

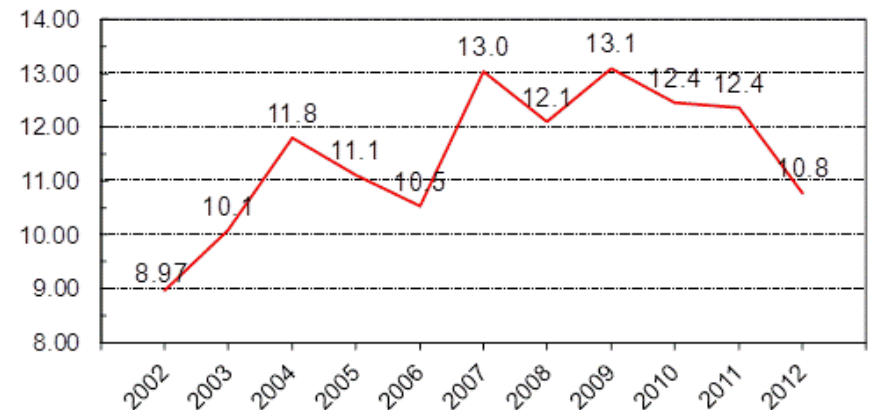

USDA-NASS  
01-11-13

In 2012, U.S. growers planted a record 94 million acres of corn for animal feed, ethanol fuel, and food products

**Concern: High yield and production might have caused increased N load and soil erosion**

# US Biofuel Mandates

[Get Quote](#)

[Home](#) [Business News](#) [Markets](#) [Personal Finance](#) [Real Estate](#) [Technology](#) [Small Business](#) [Luxu](#)

## Bush signs energy bill

Raises fuel economy standards for the first time in 30 years and boosts biofuel use, but leaves out new taxes on Big Oil.

- Energy Security & Independence Act (EISA) requires 36 billion gal of biofuels by 2022
- EPA Renewable Fuel Standard (RFS) requires 25% replacement of vehicle gas in 2022, about 50% of the biofuel will be generated from cellulosic feedstock.

# State-of-the-Art of Studies on Water and Biofuel

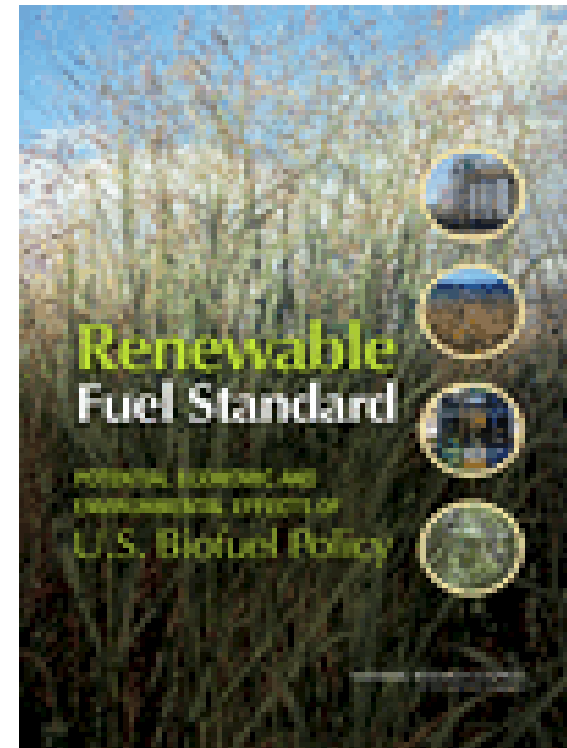
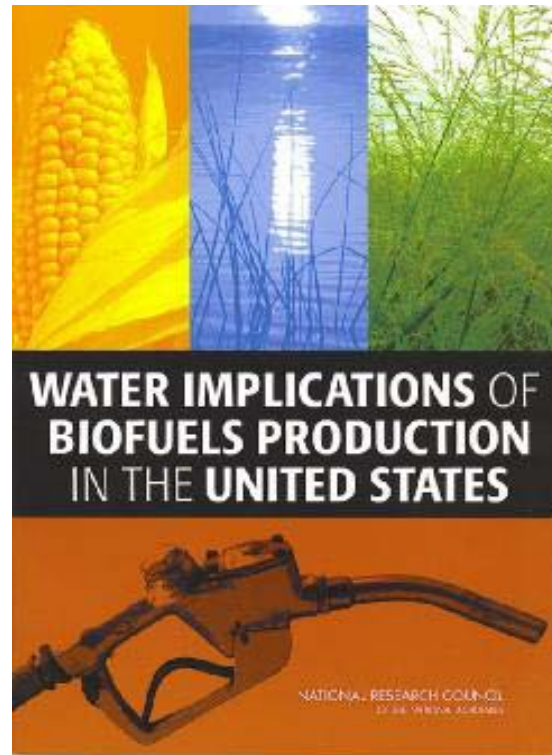
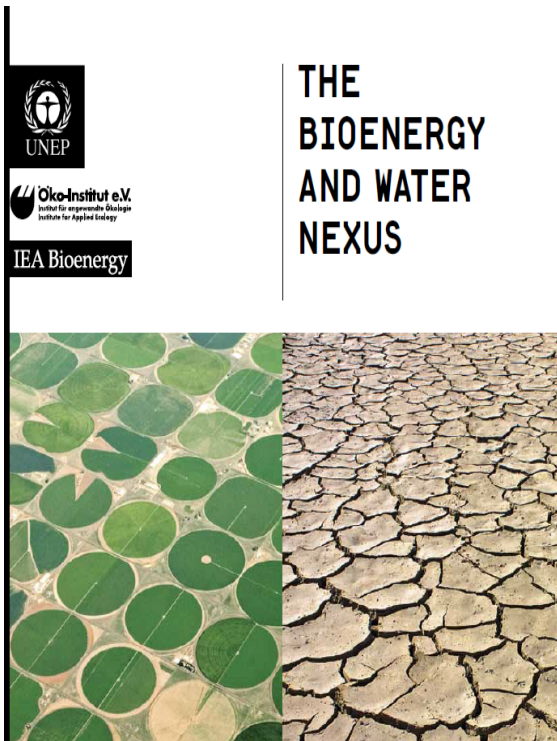

# Issues

- Water requirement and impact on hydrology
- Impact on water quality
- Economic and environmental tradeoffs
- Food vs. fuel (competing for resources)

# Water Requirements for Biofuels and the Environmental Impacts

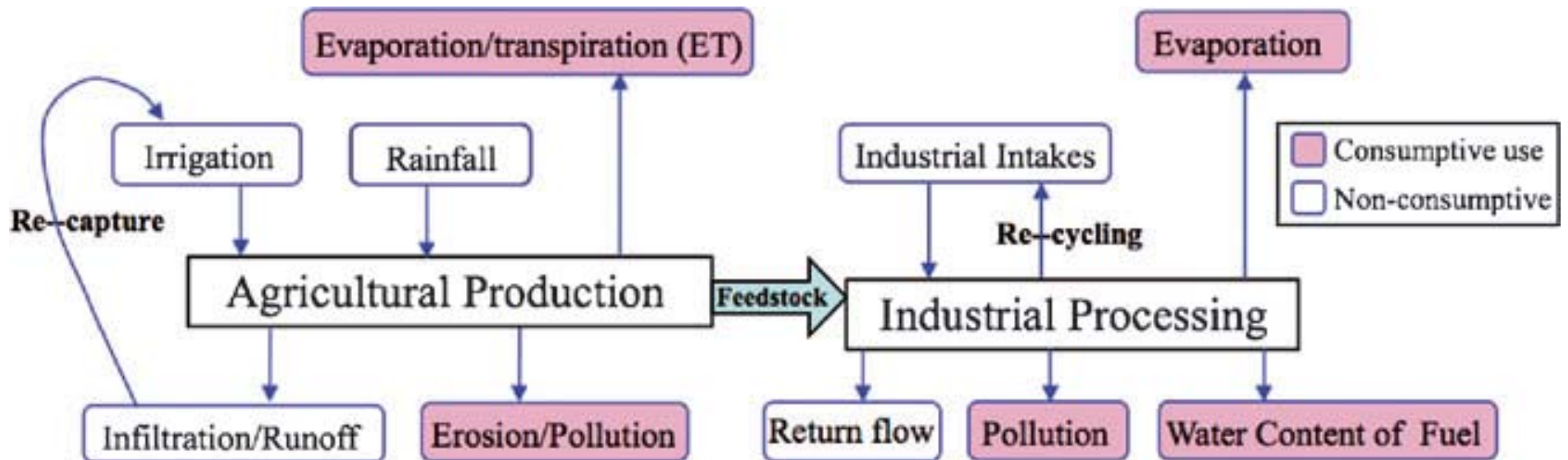

(Sources: Fingerman et al., 2011, *Biofpr*)

# Water Requirements for Biofuel

Bioenergy is the biggest water consumer compared to other energies

- It takes an average of roughly 2,500 liters of water to produce 1 liter of liquid biofuel
- Water consumption for energy production in the US will jump two thirds between 2005 and 2030, and about half of the increase is due to growing biofuels (Service, 2000)
- Replacing 10% of global energy consumption with 1<sup>st</sup> generation biofuel would double agricultural water withdrawals in the world (Source: The World Economic Forum: Water Initiative)

## WATER REQUIREMENTS FOR ENERGY PRODUCTION (Liters per megawatt hour)

Petroleum Extraction	10-40
Oil Refining	80-150
Oil shale surface retort	170-681
NGCC* power plant, closed loop cooling	230-30,300
Coal integrated gasification combined-cycle	~900
Nuclear power plant, closed loop cooling	~950
Geothermal power plant, closed loop tower	1900-4200
Enhanced oil recovery	~7600
NGCC*, open loop cooling	28,400-75,700
Nuclear power plant, open loop cooling	94,600-227,100
Corn ethanol irrigation	2,270,000-8,670,000
Soybean biodiesel irrigation	13,900,000-27,900,000
*Natural Gas Combined Cycle	

(Source: Service, 2009, *Sci.*)



# Water Requirement and Impact on Hydrology

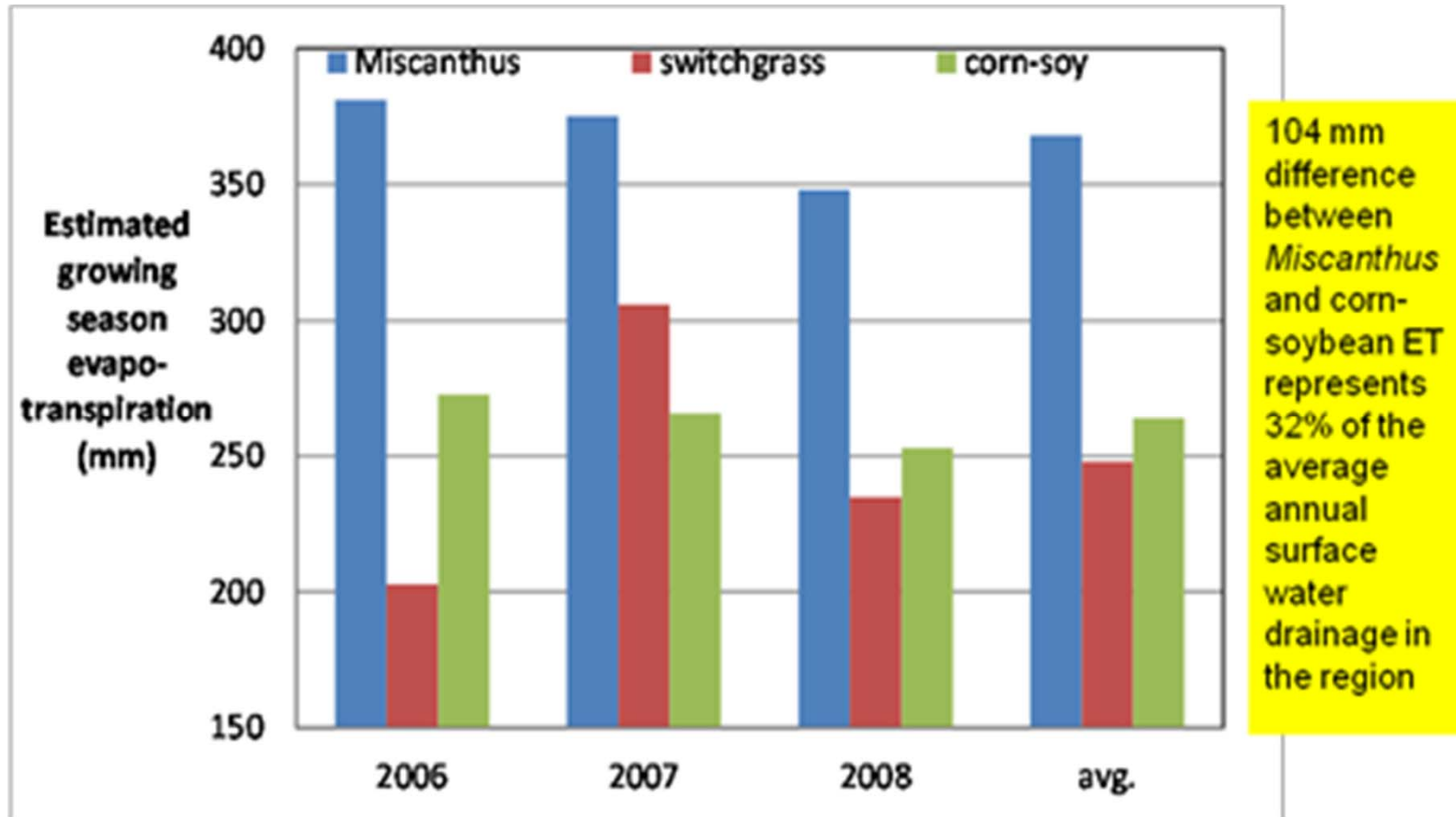

(Source: McIsaac et al., 2010).

# Water Requirement and Impact on Hydrology

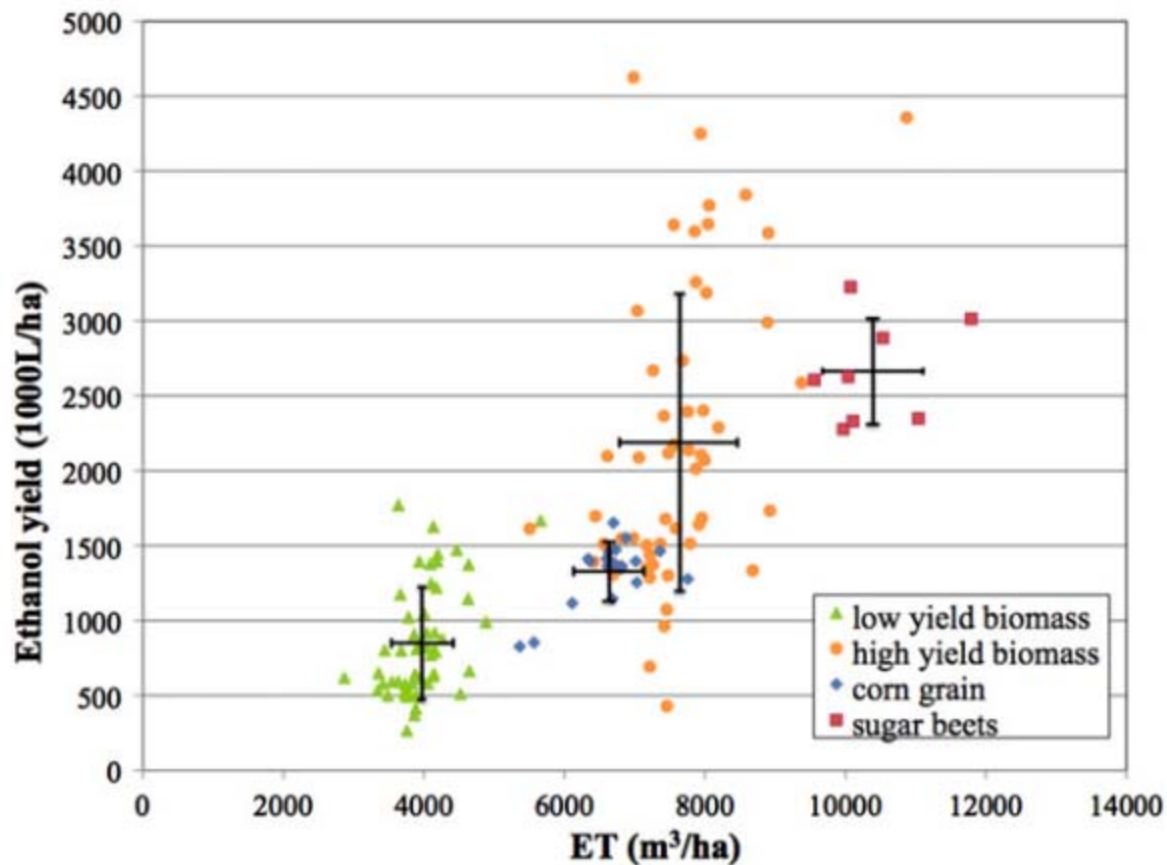

ET and yield for counties in California

- High-yield biomass: dedicated energy crops such as Miscanthus
- Low-yield biomass: grassy fodder crops

(Source: Fingerman et al., 2010, ERL)

# Water requirement for biofuel processing

- The range of processing water requirements for a typical ethanol refinery is 2-10 Lw/Le
- By average, 100 million gallon/year corn ethanol plant uses 600 million gallons of water, the equivalent of a town of ~ 7000 people
- Local water problems (such as aquifer drawdown) can be caused or enhanced by biofuel production



# Impact on Water Quality

- Corn-based biofuel production can cause 8 g N exported to Gulf of Mexico and 20-40 lb of soil eroded per gal ethanol (Credit: Jerry Schnoor)
- Farmers switched land from conservation reserve program (CRP) for biofuel production, which potentially increase chemical leaching and sediment erosion risk
- Cellulosic feedstocks have considerable potential to sequester nutrients in its root system, and require less fertilization than corn, thus resulting in a low nutrient runoff, e.g., 50% land change to Miscanthus can lead to decrease in nitrate load of 30% (Ng et al., 2010, EST)

# Impact on Water Quality

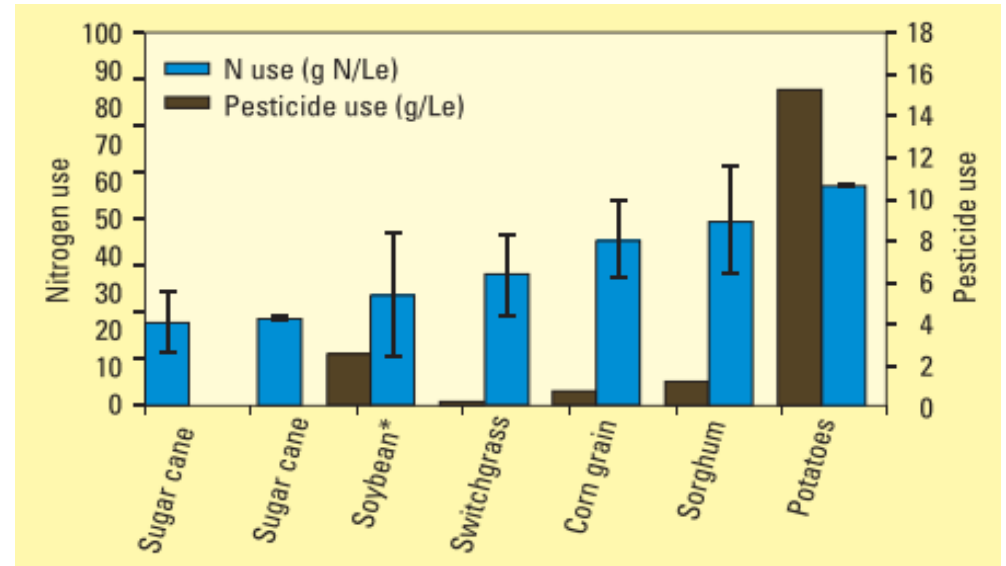
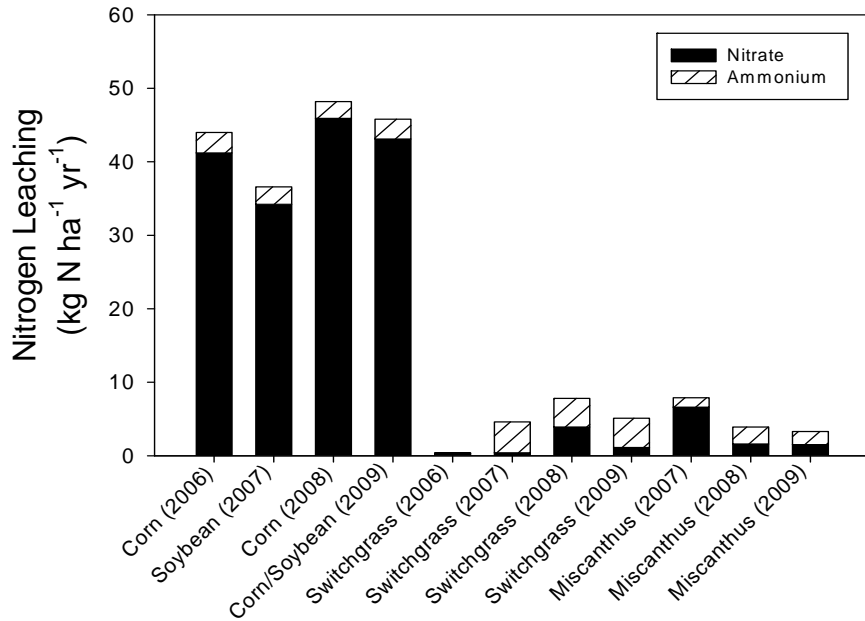

## Inorganic N Leaching below 50 cm

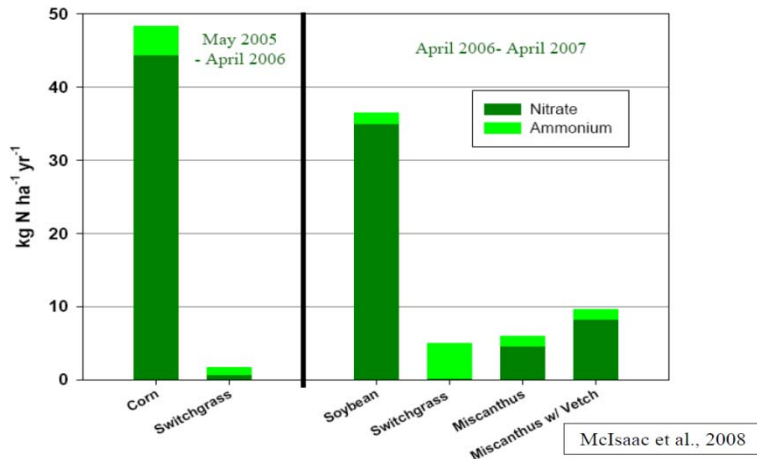

**Nitrogen and pesticide requirements for producing 1 L of ethanol (if fertilized) from different crops. Source: Dominguez-Faus, 2009, EST**

# Impact on Water Quality

Discharges from the refinery plants may cause potential chemical, biological, and thermal pollution to aquatic systems (regulation on 0-discharge)



# Case study I: A “system of systems” model for infrastructural support for biofuel development

- Transportation
- Refineries
  - Location of refineries
  - Expansion over years
  - Refinery and water use
- Land use
- Water supply and quality
  - Stream flow
  - Nitrate load

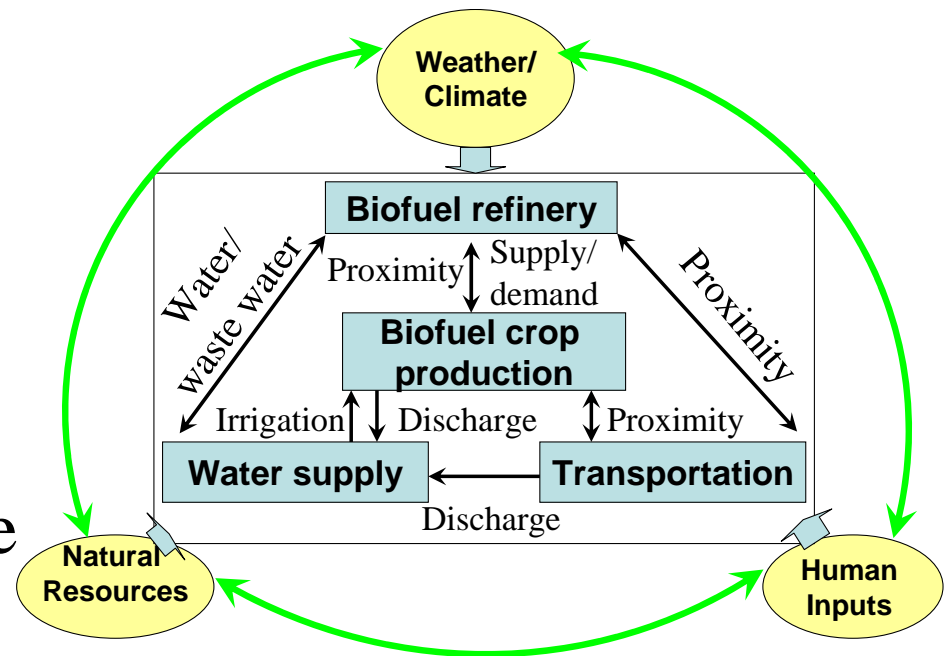

Interdependence of infrastructures and interactions with the society and environment

(Source: X. Cai group)

# Impact of Different Levels of Mandate

- Up to 50% of mandate the watershed experiences a modest change in flow/nitrate load regimes and slight change in concentration.
- Nitrate reduction level exceeds the flow reduction level

## Monthly Flow regime curves and nitrate load

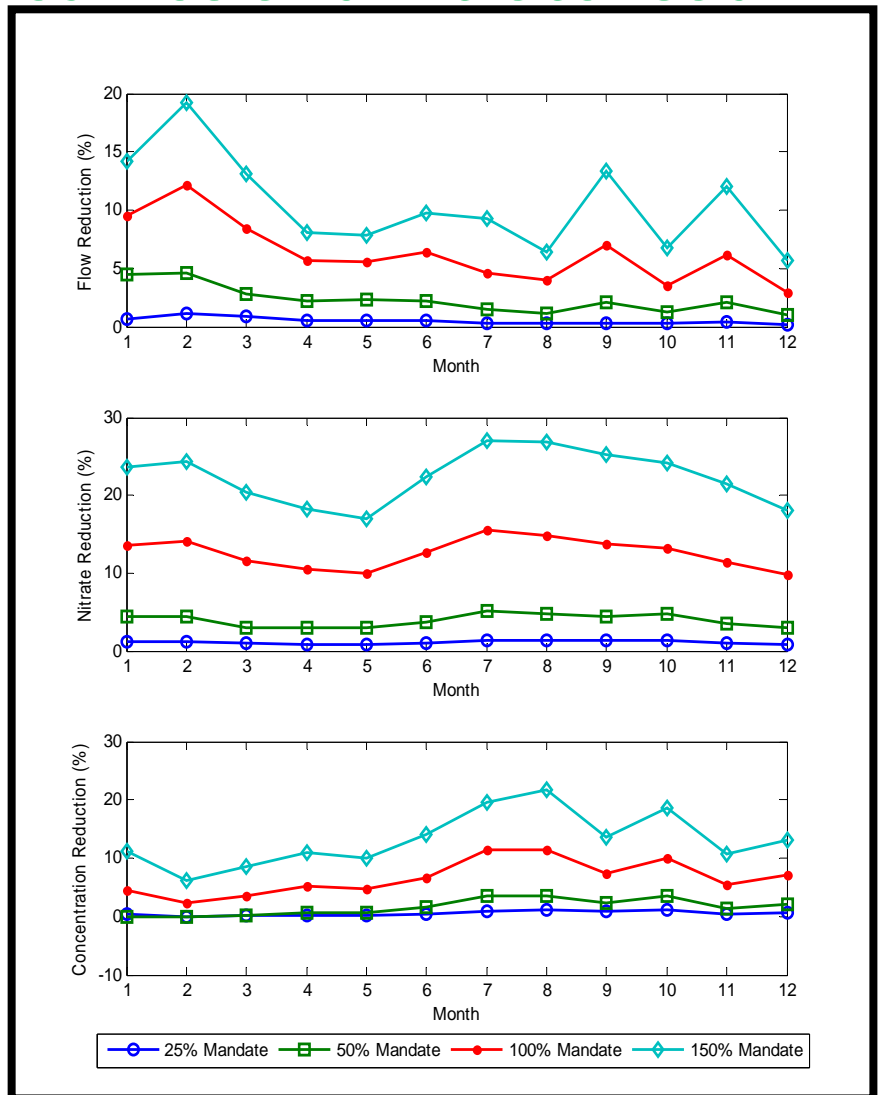



# Impact of Streamflow Constraints

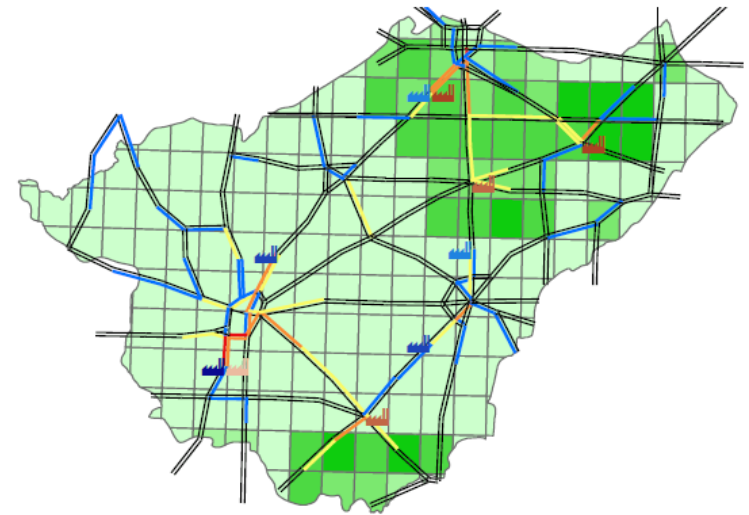
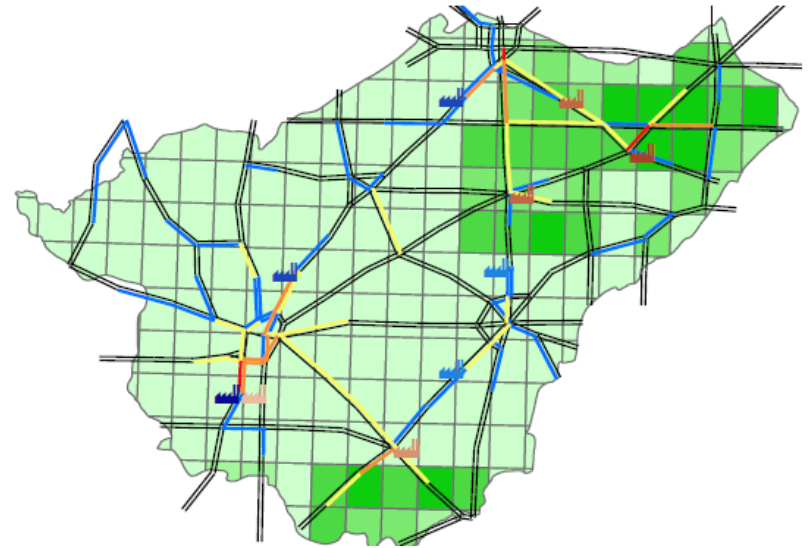
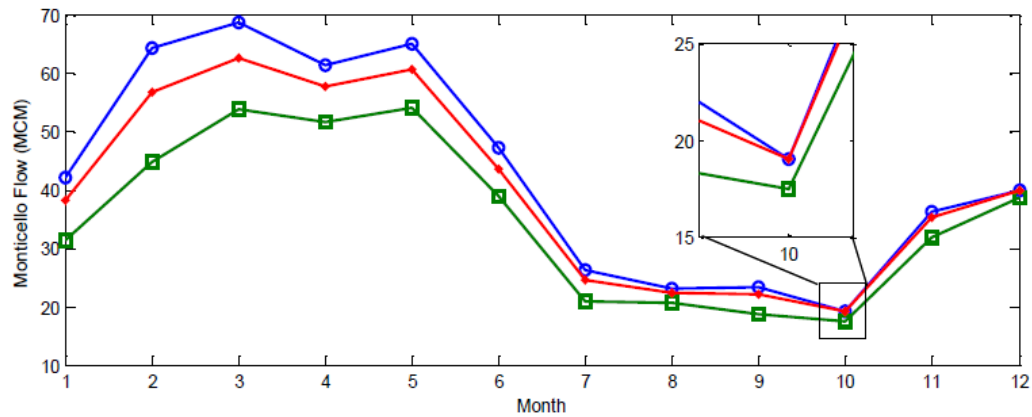

—○— BAU    —■— 100% Mandate    —▲— Constrained Monticello Flow

# Impacts of Water Quality Constraints (to insure 20% annual N reduction)

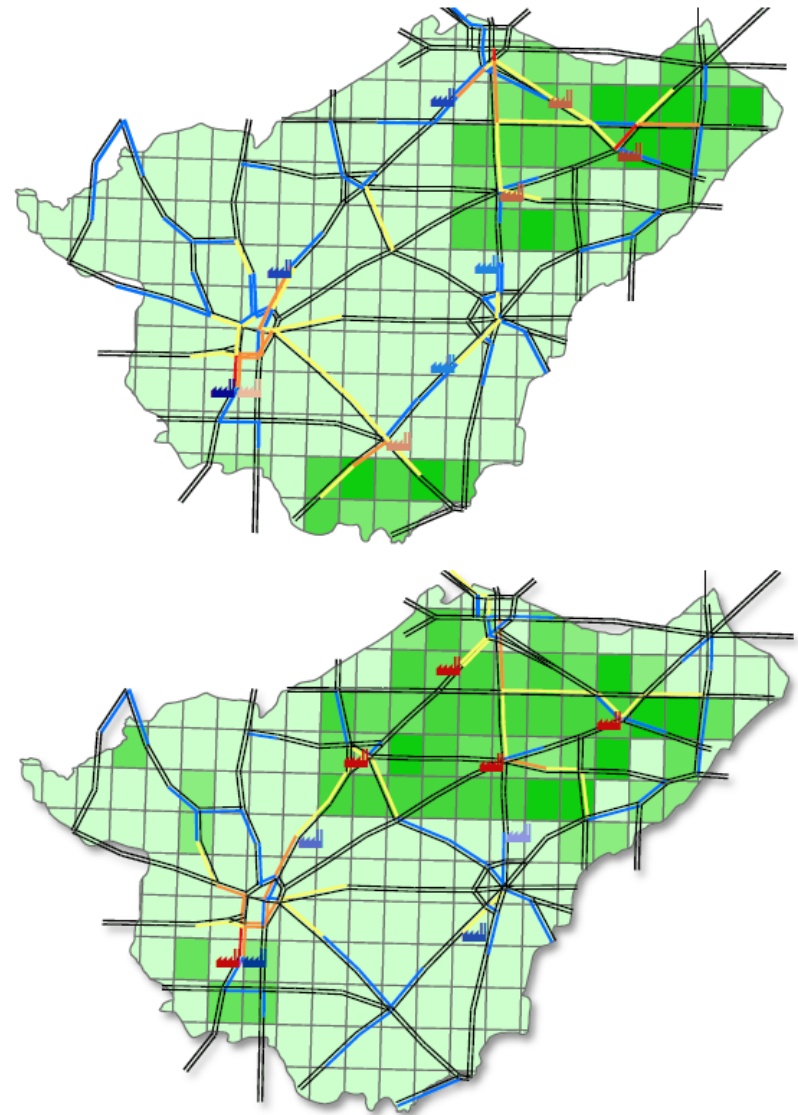
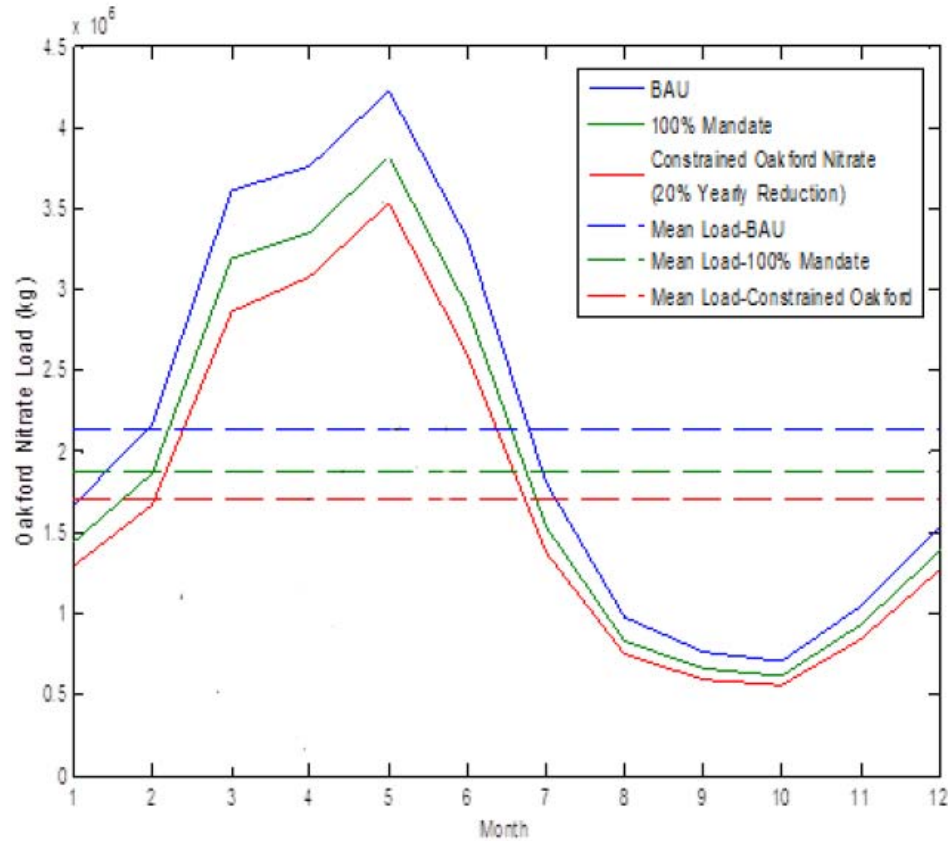

# Economical Impacts of Environmental Policies

Imposing different levels of nitrate reduction to examine profit loss

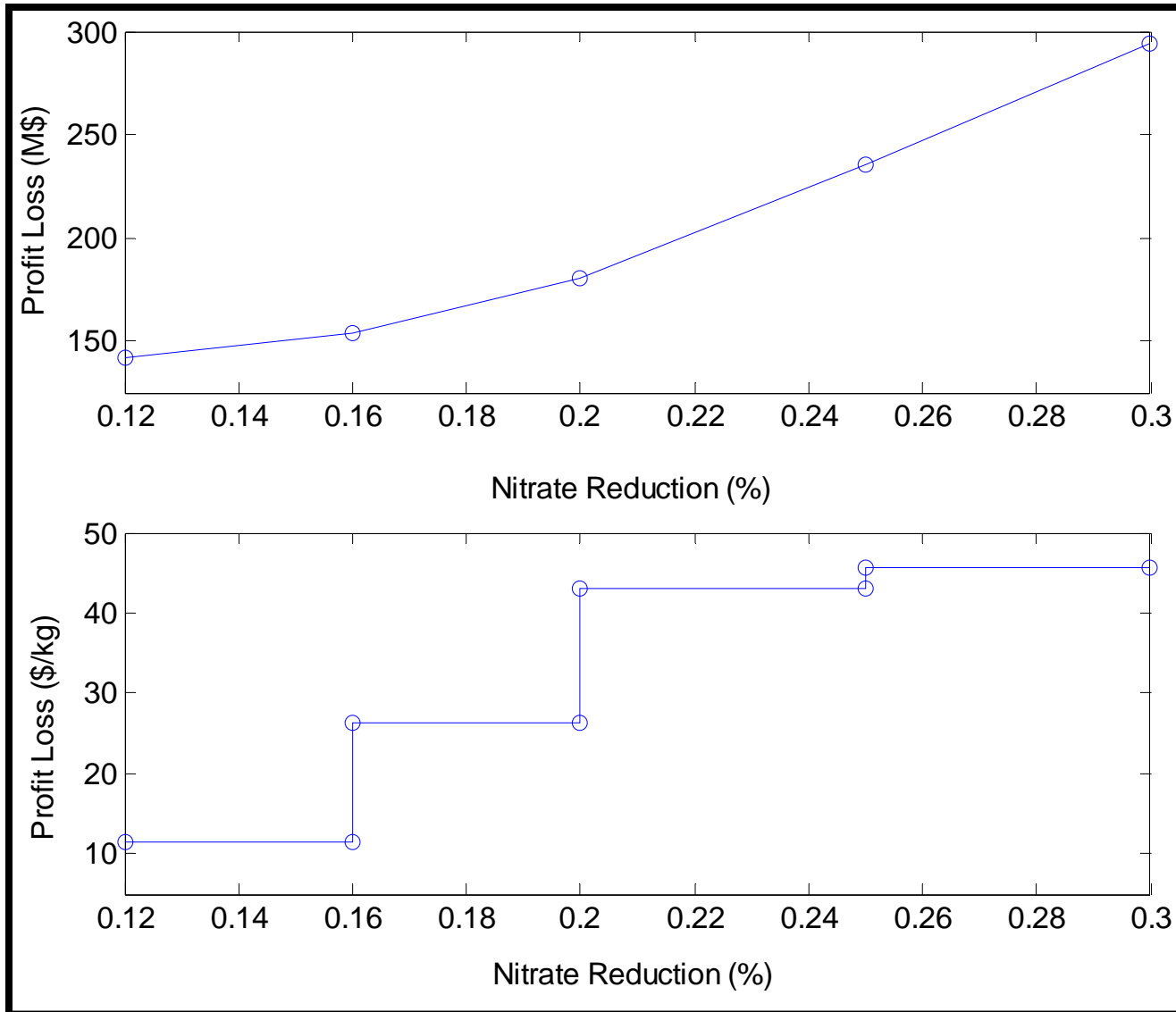

# FOOD OR FUEL?

Nearly a billion people will go hungry tonight, yet this year the U.S. will turn nearly 5 billion bushels of corn into ethanol. That's enough food to feed 412 million people for an entire year.

8 BUSHELS OF CORN = 21.6 GALLONS OF ETHANOL FUEL OR ENOUGH FOOD TO FEED A PERSON FOR A WHOLE YEAR



#### DOING THE MATH...

5 billion bushels / 8 bushels of corn (enough calories to feed a person for a year) = sufficient calories to support 625 million people, minus one-third to account for distiller's grain (DDG) = 412 million

8 bushels of corn (feeds a person for a year)  
X 2.7 gallons of ethanol per bushel  
= 21.6 gallons of ethanol per bushel

#### SOURCES

450 pounds of corn supplies enough calories for one person for a year (<http://www.foreignaffairs.com/articles/62609/c-ford-runge-and-benjamin-senauer/how-biofuels-could-starve-the-poor>)

About 5 billion bushels of U.S. corn production is slated for ethanol production (<http://www.usda.gov/oca/commodity/wasde/latest.pdf>)

One bushel of corn produces 2.7 gallons of ethanol (Purdue Extension, "How Fuel Ethanol is Made From Corn," <http://www.extension.purdue.edu/extmedia/ID/ID-328.pdf>)

  
resource media

# Food and Fuel Competing for Land and Water

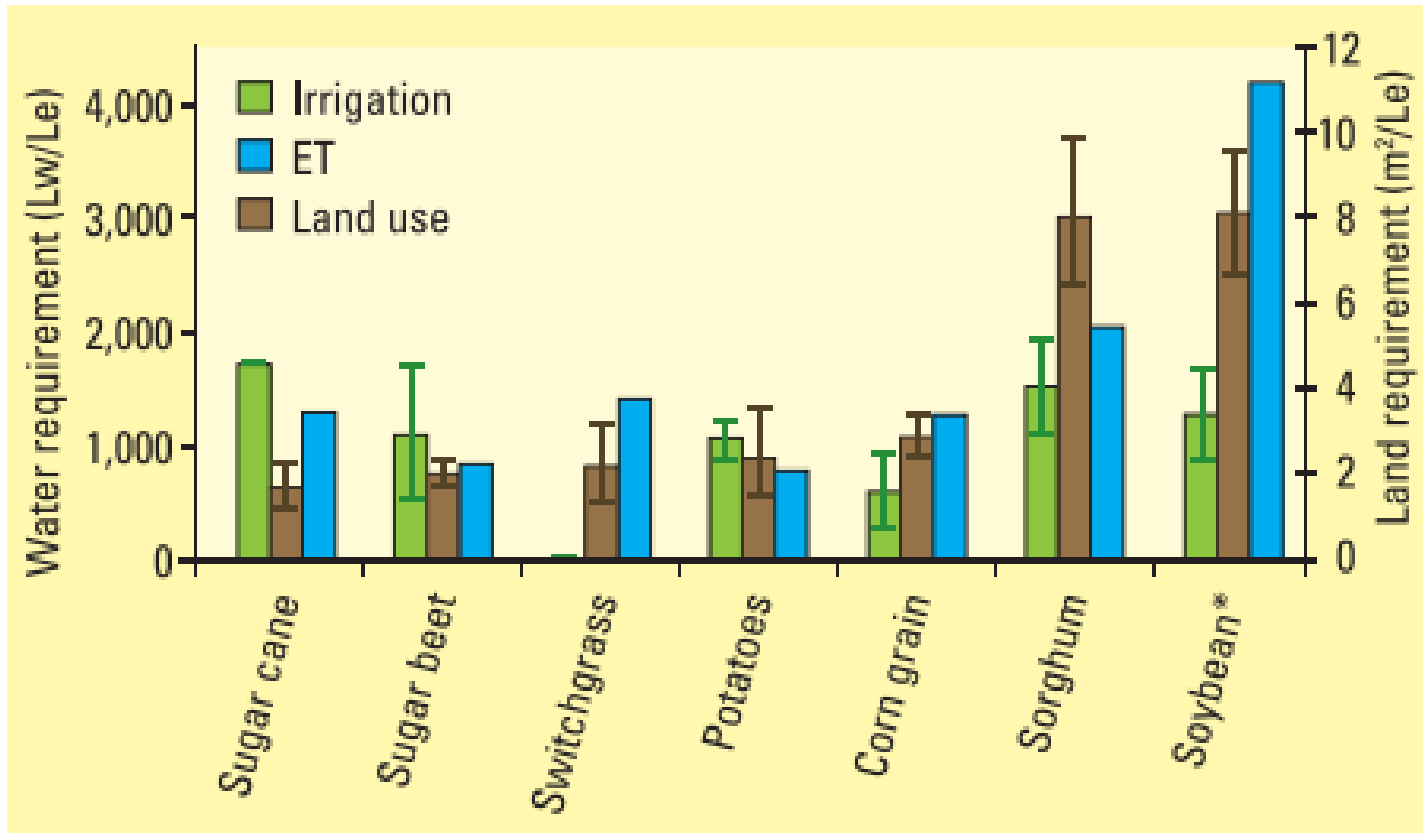

Evapotranspiration, irrigation, and land requirements to produce 1 L of ethanol in the U.S. from different crops

(Source: Dominguez-Faus, 2009, EST)

# Food vs. Fuel

Although the impact is extremely difficult to assess, bioenergy production is estimated to have caused up to 70%-75% of the rise in the global prices of some food stocks, including approximately 70% of the increase in maize prices. This can lead to:

- More irrigation for producing both food and fuel by using marginal land with inadequate precipitation
- More use of fertilizer and pesticide to increase yield
- Land use expansion: Marginal lands require even higher fertilizer application and are more susceptible to erosion

# Economic and Environmental Tradeoffs

- Different feedstocks differentiate in term of biomass productivity, economic efficiency, carbon emission reduction and impact on water quantity and quality
- 1<sup>st</sup> generation crops (e.g., corn) have lower costs, **higher carbon emission and higher nitrate load**
- Cellulosic biofuel crops have **higher cost**, lower carbon emission, lower nitrate load, and **higher water requirement**
- Which biofuel crop is more sustainable?

# Case Study II: Price, Feedstock Choice and Impact on Flow and Water Quality

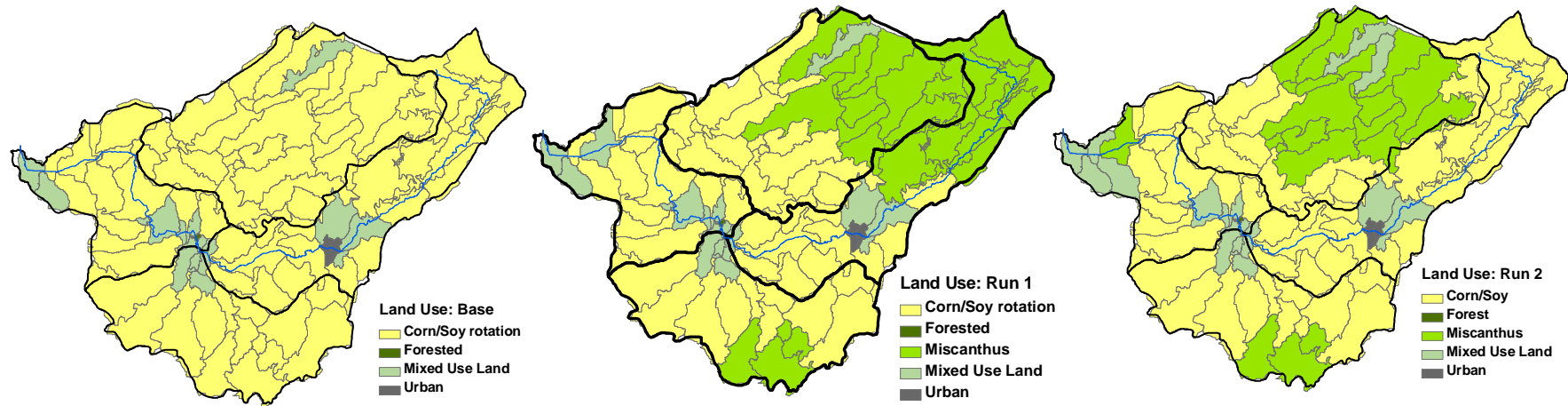

- **Base** run is the optimized land use case under current prices and conditions (*left*)
- **Run 1** represents an increase of 15% in the price of ethanol (*center*)
  - **Economic change that causes *Miscanthus* to become a profitable crop**, and thus areas of high *Miscanthus* yield switch to the new crop.
- **Run 2** represents a minimum flow requirement (“historical” minimum; here, the Base case) placed at the Monticello gauge (*right*).

(Source: X. Cai group)



# Coupled System Trajectory

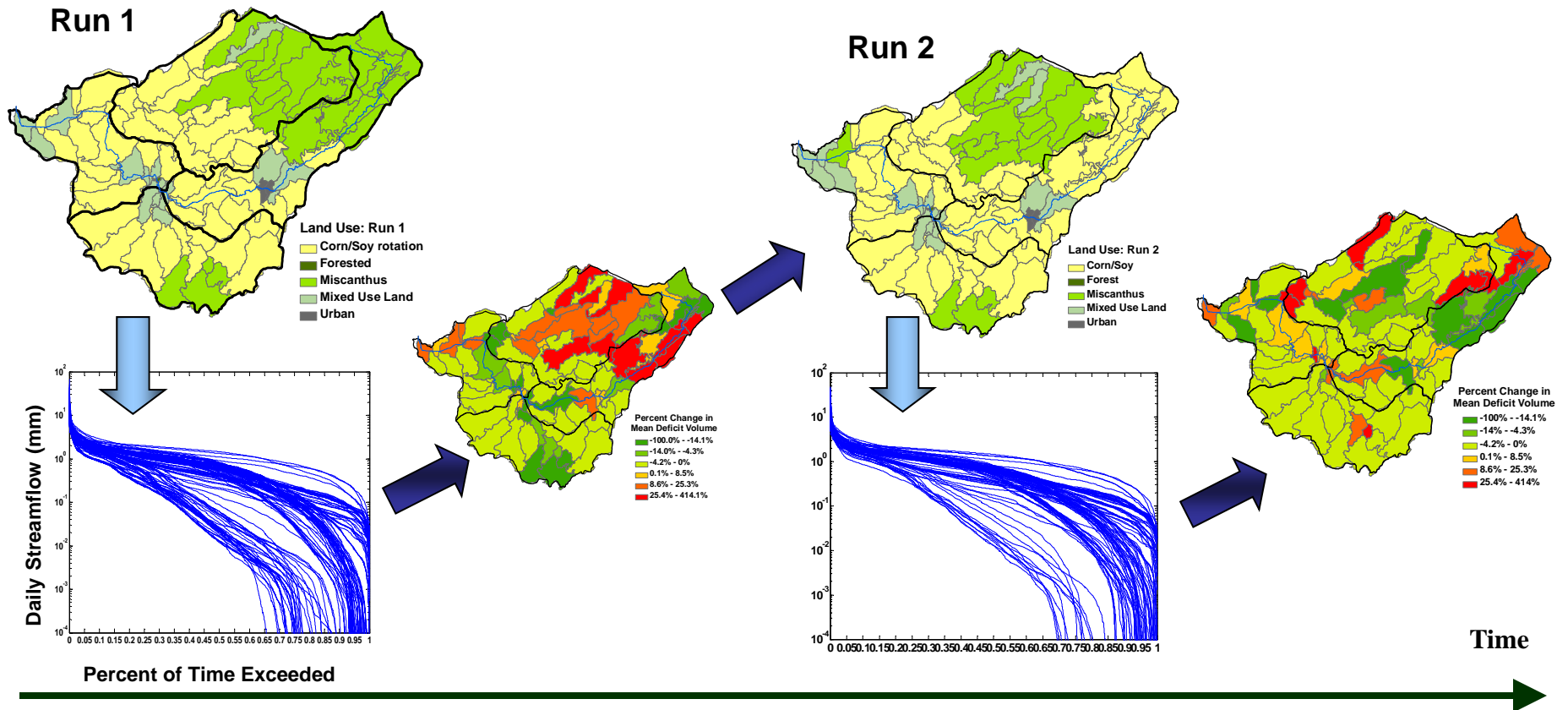

- Shifting the location of Miscanthus within the basin (Run 1 to Run 2) reduced deficit volumes relative to Run 1 (variable response)
  - Effect is shown as percent change in mean deficit volume using Q85 threshold.
- In the south, Miscanthus did not appear to have a large effect on the headwater streams in which it was planted.
  - Effects showed up downstream.

## Outlook for Research

- Examining local suitability: Land, water and infrastructure, followed by considering the scale of economy
- Feedstock choice: dealing with multiple-aspect of tradeoffs and uncertainty with cellulosic crops. Which one is more sustainable?
- Integrated economic-environmental analysis: Considering the loss/gain of environmental value
- Water reallocation among food, fuel, and environment
- Conducting more careful studies on the effects of biofuel water use on environmental flow, regional climatic variability, and local and regional water stress

# Outlook for Research

- Taking into account possible beneficial effects/synergies (UNEP, 2011), e.g. for food and fuel production through combined systems, irrigation using water with marginal quality, or using marginal land (Cai et al., 2011, EST)
- Exploring global opportunities in virtual resources trade (water and land) in the world
- Exploring policy and economic incentives for 2<sup>nd</sup> and even more advanced biofuel crops (specifically for tradeoff management)

# Outlook for Research

- Adopting drought-tolerant or less-water consumptive feedstock with reasonable productivity



**Low-input high-diversity (LIHD)  
mixtures of native perennials  
(Tilman, 2006, SCI)**



**Hydrogen production, green algae  
as source of energy**



# Energy & Water

Roland L. Moreau – ExxonMobil Upstream Research Company

NSF Energy-Water Nexus Workshop

June 10-11, 2013 – Alexandria, VA

**ExxonMobil**

Taking on the world's toughest energy challenges.™

# Agenda

---



- **Overview of global water cycle & demand**
- **Water Use in Oil & Gas Industry**
- **Unconventional Energy Challenges**
- **Key Points**



# Population & Economic Growth Drive Demand for Water & Energy



**Population**  
Billion People

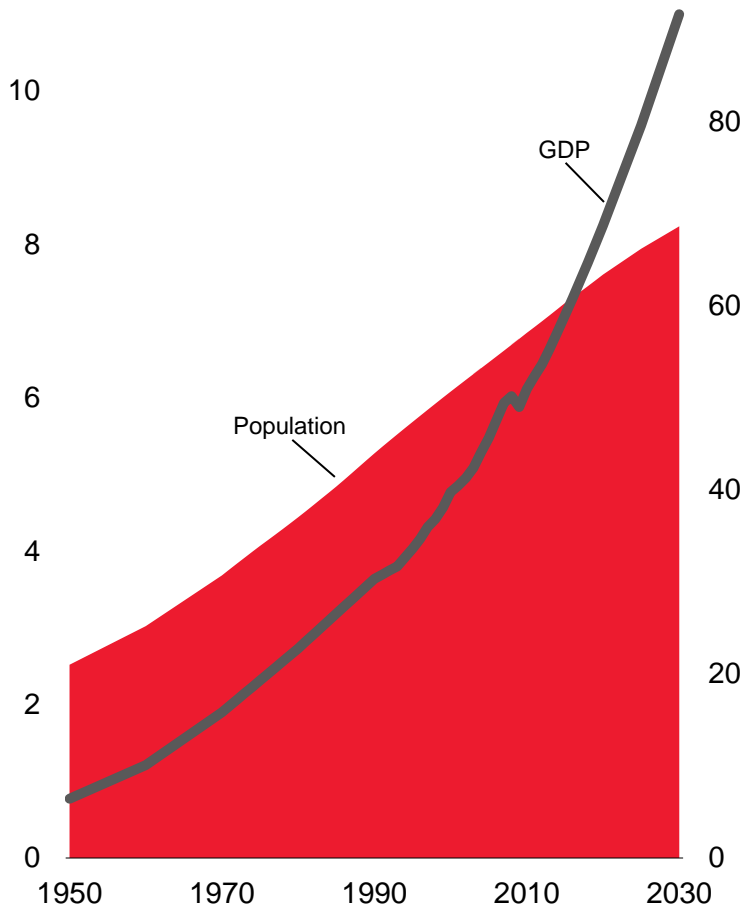

**Freshwater Use**  
km<sup>3</sup>

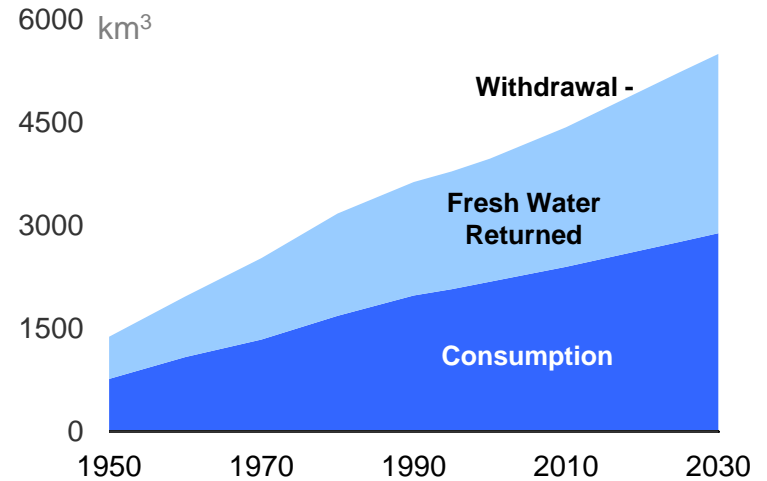

**Energy Demand**  
Quadrillion BTUs

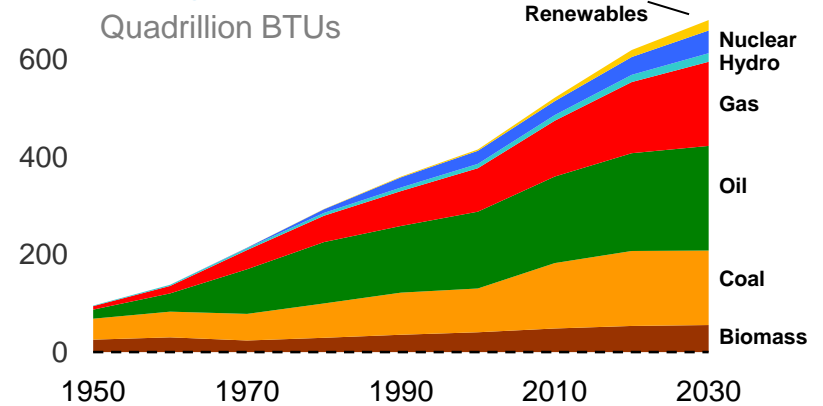

Population, GDP and Energy Demand from ExxonMobil 2013 Outlook for Energy,

Freshwater Use from UNESCO & State Hydrological Institute, St. Petersburg (Shiklomanov)



Taking on the world's toughest energy challenges.™

# Global Energy Demand by Sector

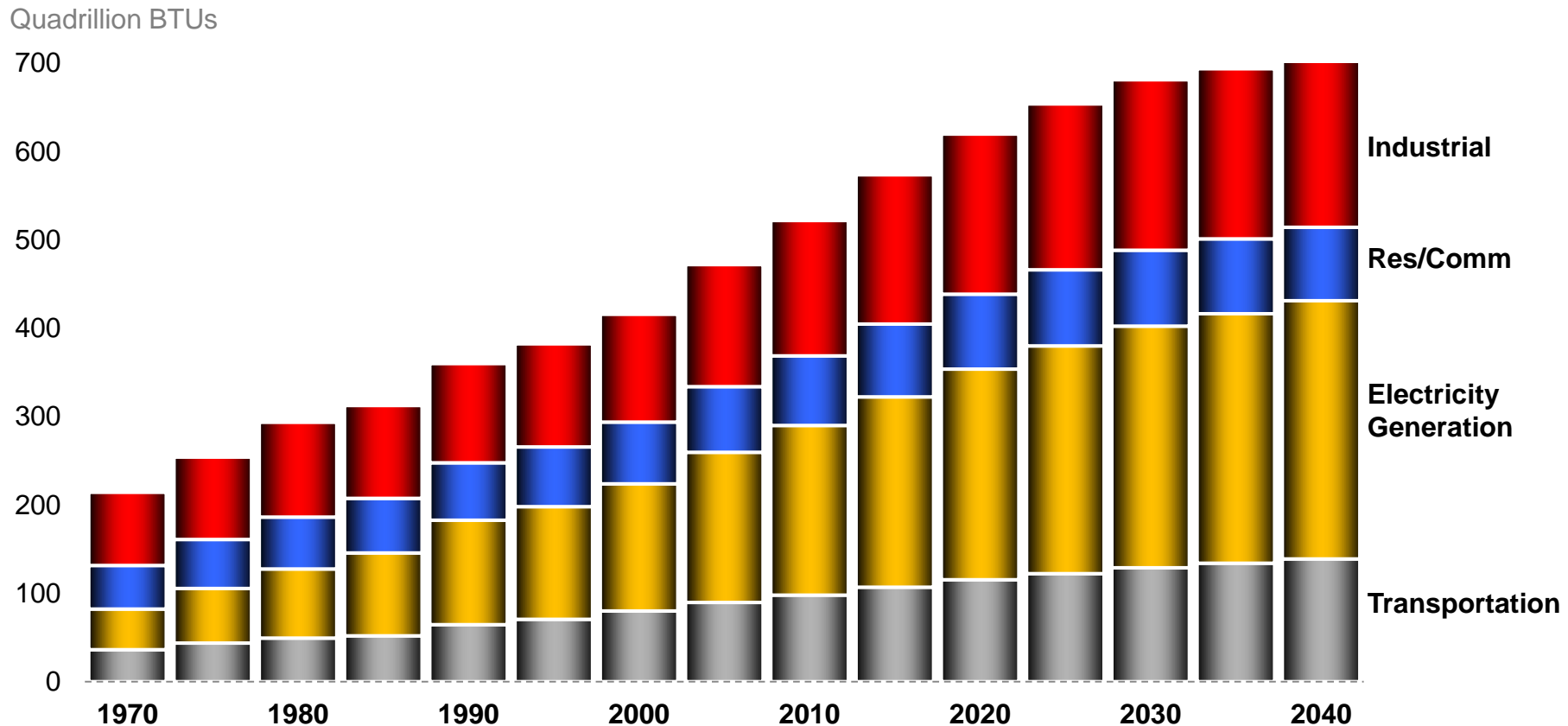
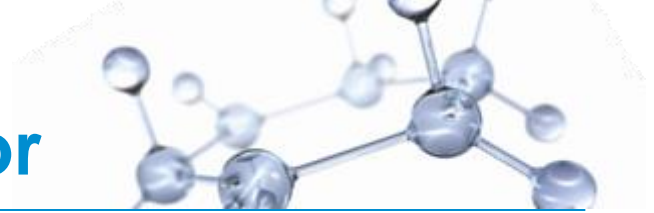



# Freshwater Use by Sector

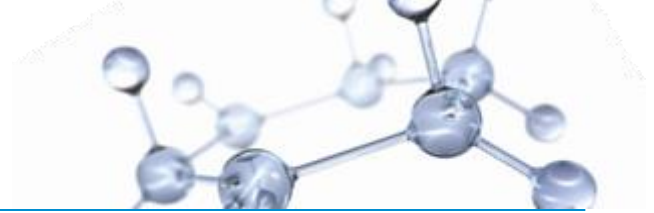

Global Freshwater Withdrawals by Sector

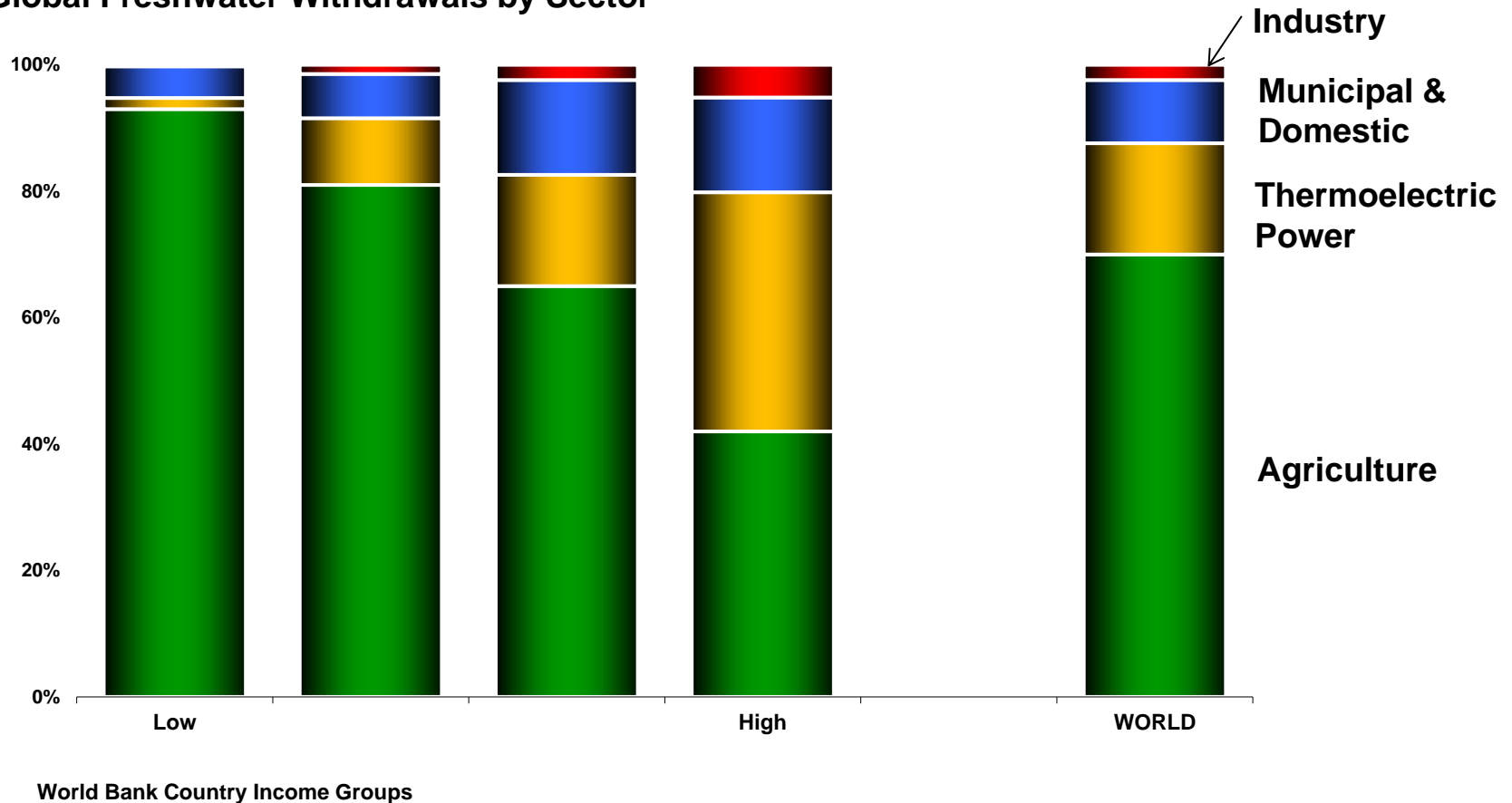

Source (left): *after* World Bank 2011 World Development Indicators  
 Source (right): Brown, T. C. (2000), Projecting U.S. freshwater withdrawals, *Water Resour. Res.*, 36(3), 769–780, doi:10.1029/1999WR900284.

# Physical & Economic Water Scarcity

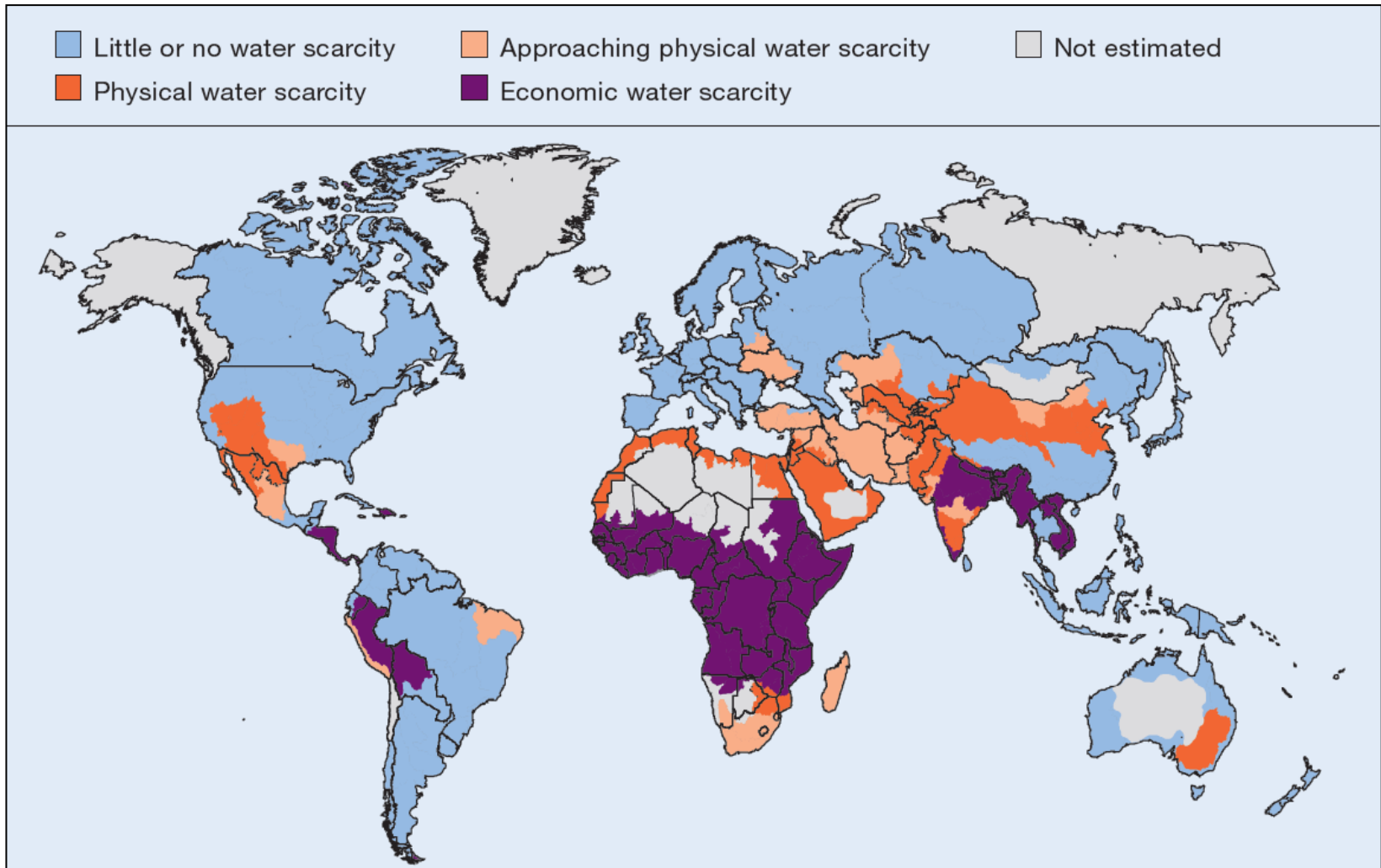

Source: International Water Management Institute (2007)

# Water Use in the Oil & Gas Industry



Water Use



## Upstream

- Exploration and production
- Modest water use during hydrocarbon extraction, but can be material local user

## Downstream & Petrochemicals

- Conversion of oil & gas to fuels and chemical base stocks
- Refining is the largest energy-related water consumer after electricity

## End Use

- Electricity generation is the most significant energy-related water consumer
- Overall modest water consumption by other end users

Graphic is slightly modified from API source  
<http://www.api.org/aboutoilgas/>

# Freshwater Intensity of Energy Production

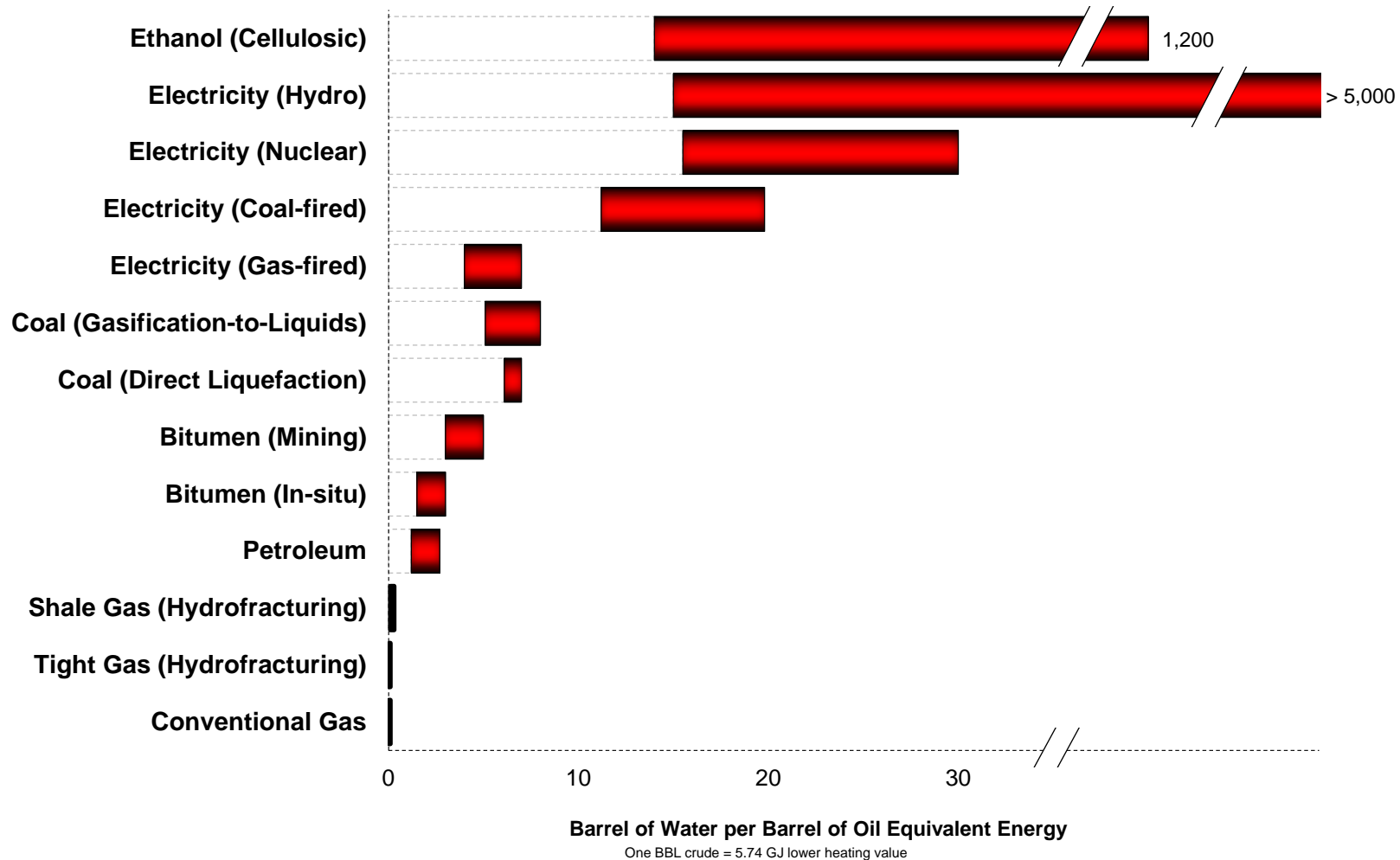

Source: internal & external reports

# Energy Intensity of Water Use

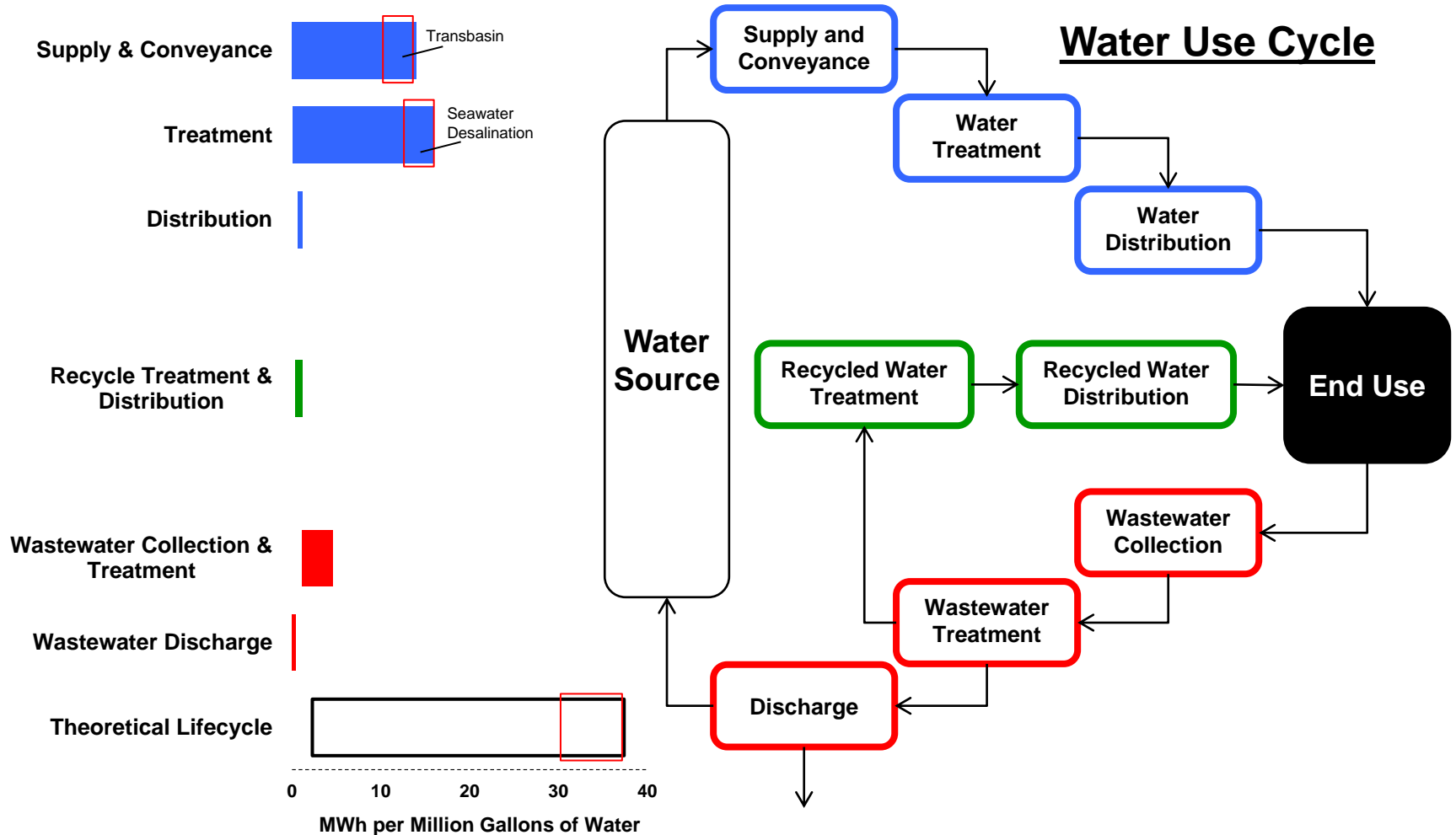
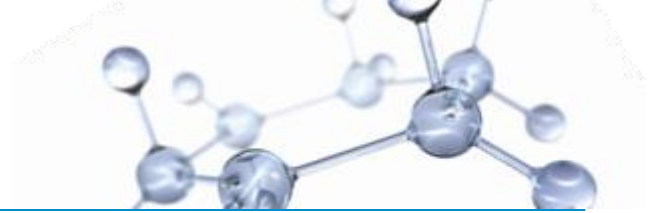

Source: CA Energy Commission 2005, Tech. Rep. CEC-700-2005-011-SF

# Protecting Water Sources

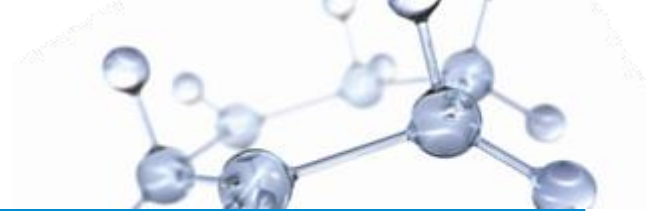

Protect human health and the environment by striving to prevent spills, and managing water withdrawal, consumption and discharges

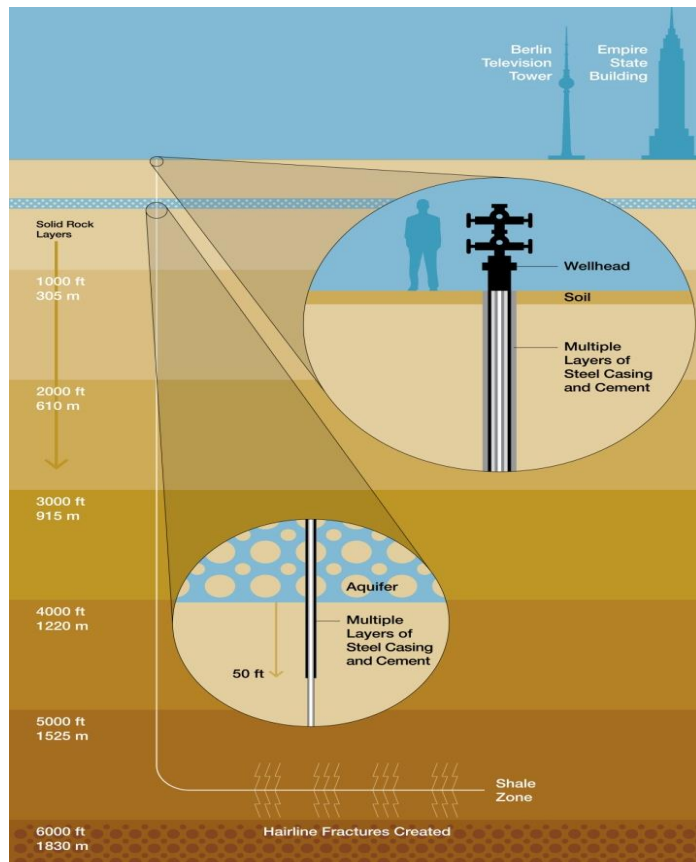

## Hydraulic Fracturing

- Groundwater protection assured by geology and well casing.
- Actual gas resource isolated by solid rock layers.
- Well encased in multiple layers of steel casing and cement.

# Elements of Hydraulic Fracturing Fluid

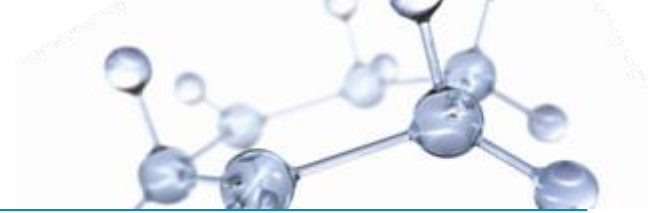

- What is hydraulic fracturing fluid?
  - The vast majority of fracturing fluid is water and sand.
  - The small fraction of remaining ingredients are other additives often found in common household goods.

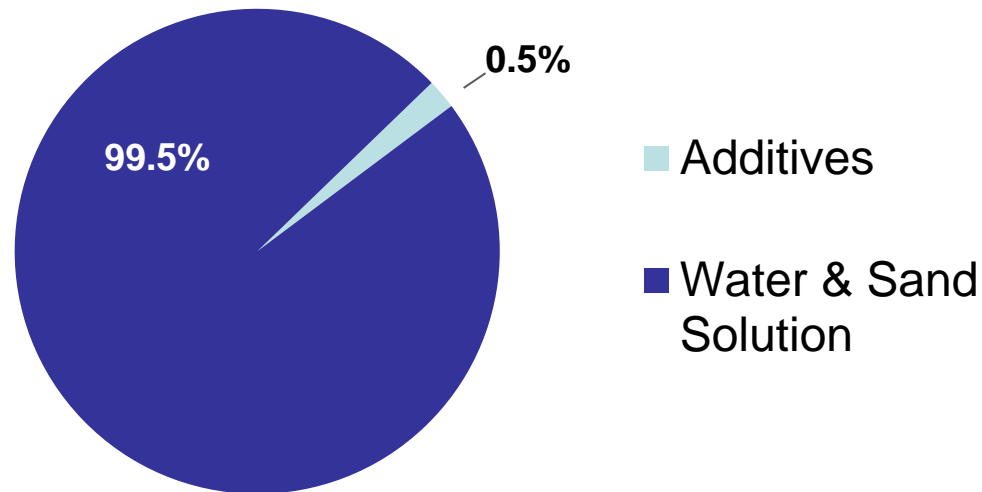

# Safe Treatment of Water After Use



- What happens to the hydraulic fracturing fluid?
  - Recycled by treating and mixing with freshwater for re-use in future operations
  - Sent to an industrial wastewater treatment plant
  - Injected underground in properly permitted wells for disposal



# Water Use – Marcellus Shale Region

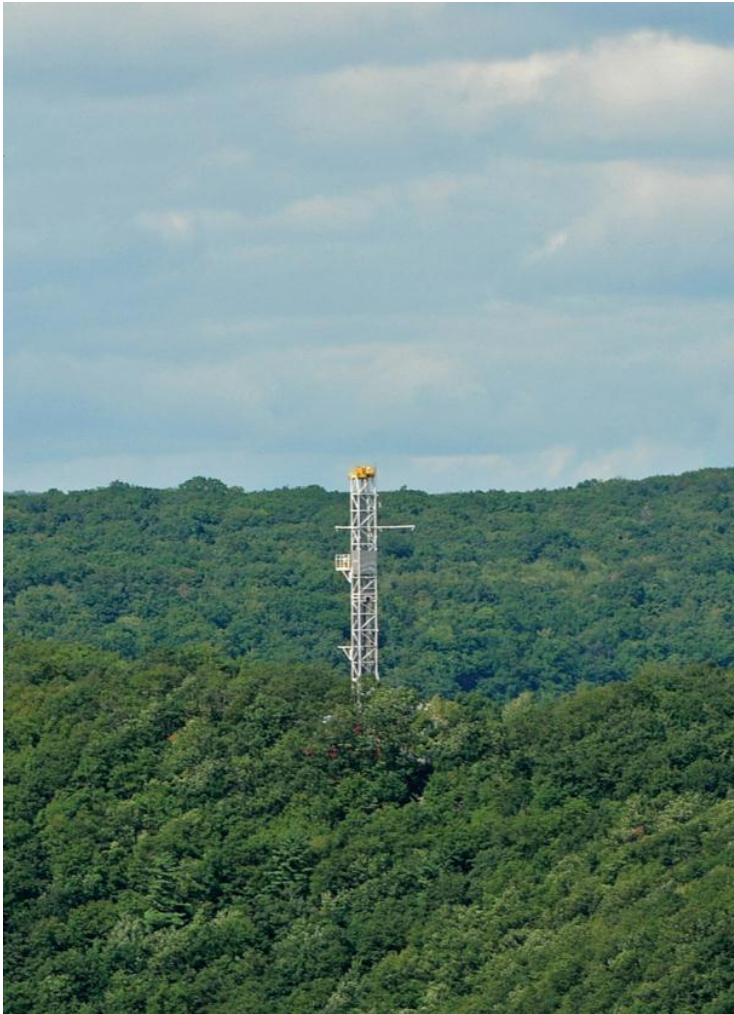

- Susquehanna and Delaware River Basin Commissions employ strict siting and surface water management requirements
- Industry will use far less than 1% of water flow in both Basins

# Water Use – Barnett Shale Region



- Water managed by multiple water management districts and municipalities
- Industry uses less than 2% of total surface water in Fort Worth Basin



# Additive Ingredient Disclosure

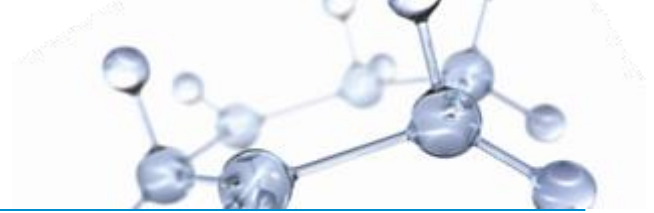

[Home](#) / [Welcome](#) / [Publications](#) / [News & Updates](#) / [Links](#)



**HYDRAULIC FRACTURING**  
HOW IT WORKS

**GROUNDWATER**  
PROTECTION

**CHEMICAL**  
USE

**REGULATIONS**  
BY STATE

**FIND A WELL**  
BY STATE

**FREQUENT**  
QUESTIONS

# WELCOME

**Welcome to FracFocus**, the hydraulic fracturing chemical registry website. This website is a joint project of the Ground Water Protection Council and the Interstate Oil and Gas Compact Commission.

On this site you can search for information about the chemicals used in the hydraulic fracturing of oil and gas wells. You will also find educational materials designed to help you put this information to use.

[LEARN MORE >](#)

**Looking for information about a well site near you?**



Search for nearby well sites that have been hydraulically fractured to see what chemicals were used in the process.

# In Summary ...

---



- **Water and energy are interrelated, and both are vitally important for society and economic development**
- **Population and economic growth drive water and energy demand**
- **Water scarcity is regional and can vary over time**
- **Water issues are most effectively addressed with local, watershed-scale solutions**
- **All stakeholders (industry, government, academia) have a valuable role to play in sustainable water solutions**
- **Petroleum industry is not an intensive freshwater user, but can be a material local water user**
- **Conduct research and operational analyses to support improvement of water-related technologies, practices, and performance**

# *Water and Energy: The Case for Distributed Water Treatment and Desalination Systems"*

**Yoram Cohen**

*Chemical and Biomolecular Engineering Department  
Water Technology Research (WaTeR) Center*



**UCLA**  
WATER  
TECHNOLOGY  
RESEARCH  
CENTER

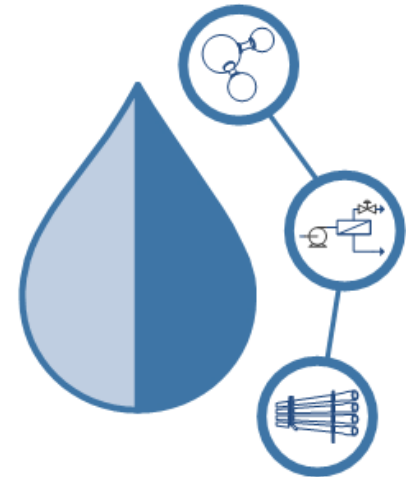

**UCLA** Engineering

HENRY SAMUELI SCHOOL OF  
ENGINEERING AND APPLIED SCIENCE

<http://www.watercenter.ucla.edu>

# Outline

Water and energy are inextricably linked

The cost of water and water energy needs – The California Example

Energy use in RO desalination & opportunities for improving process efficiency

Centralized versus distributed water systems

The benefits of distributed water systems and Research Needs

Examples of small distributed water treatment systems (cooling tower blow down water, seawater, brackish water, graywater)

Modern centralized water treatment plants – R&D Needs

# Water and Energy Are Inextricably Linked

Water is used in the generation of 33% of CA electricity

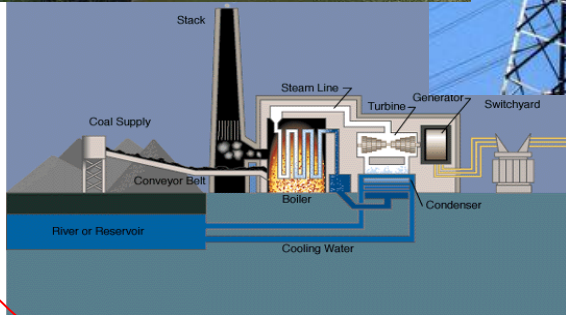

Reduced water conveyance and increased water recycling



Decreased energy consumption and smaller carbon footprint

Water-related energy use: 19% of CA electrical energy and 30% (non-power plant) natural gas

# Water Networks & Energy

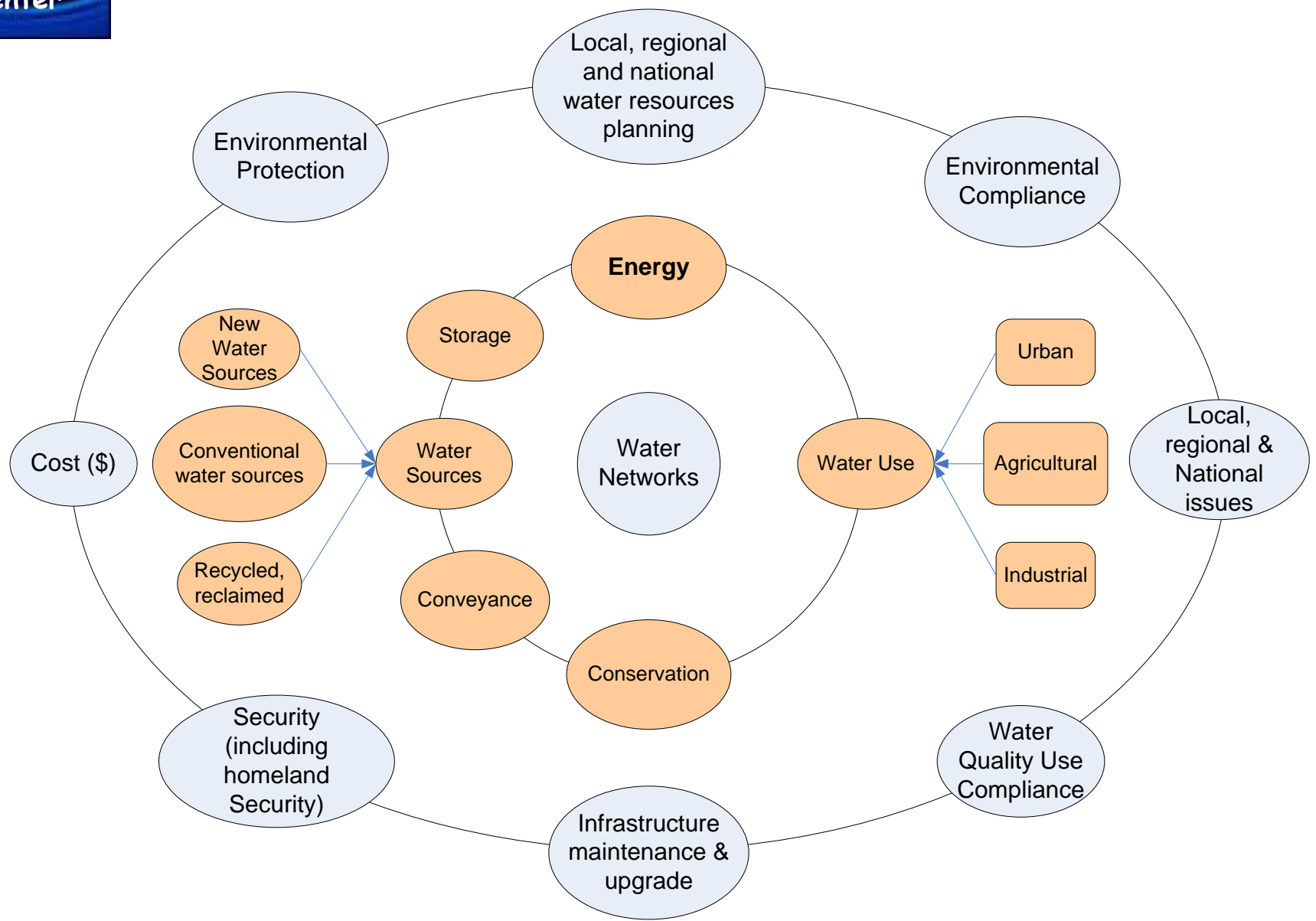



# California Water Supply



# California Water Supply

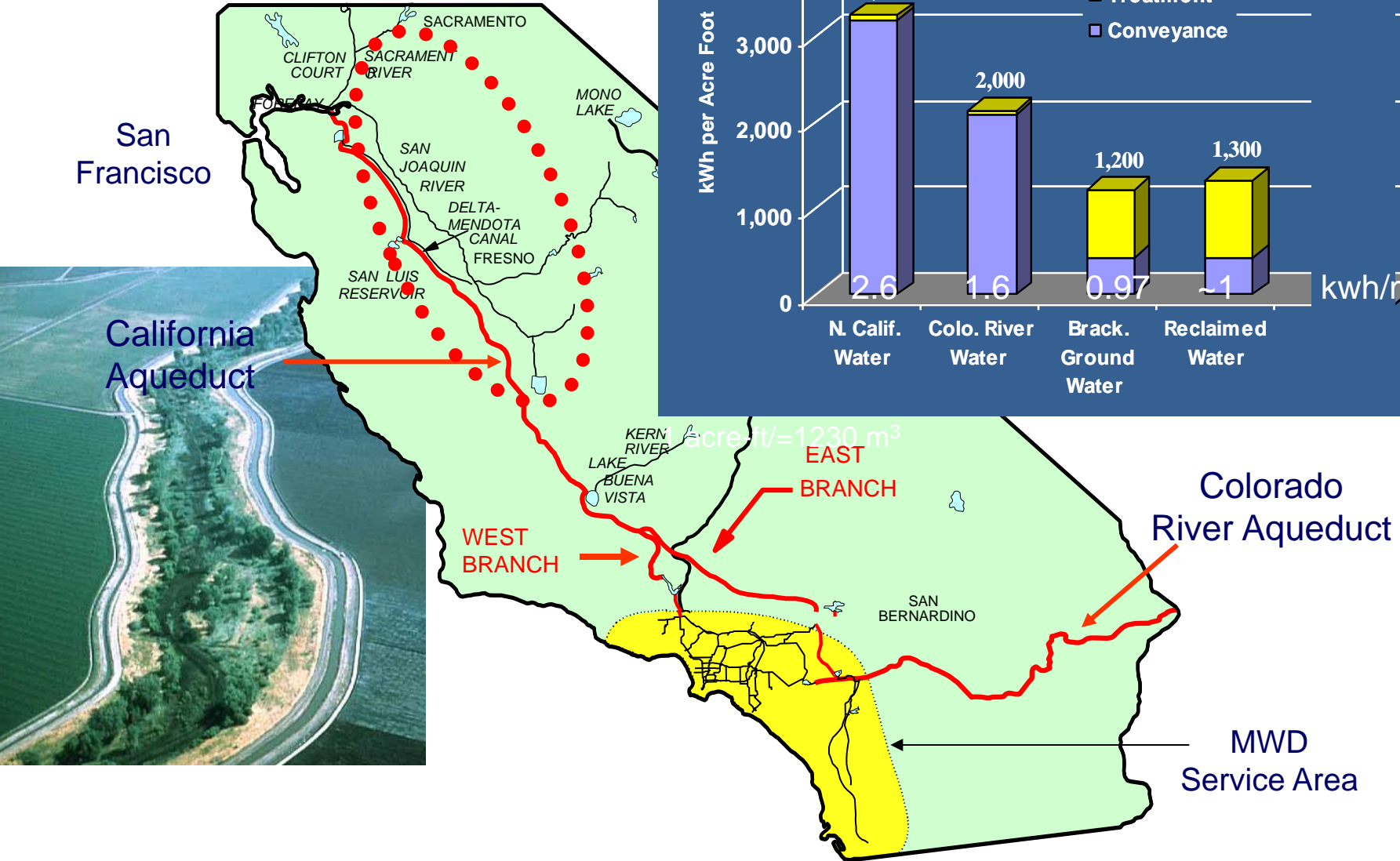
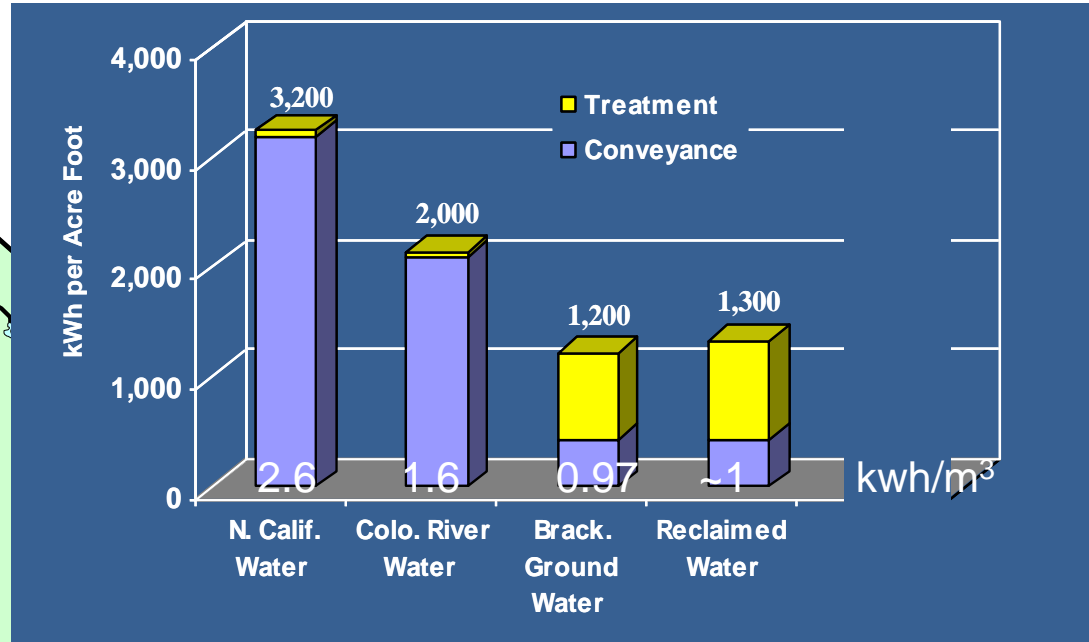

# Water Energy Use for Water Production, Treatment & Distribution

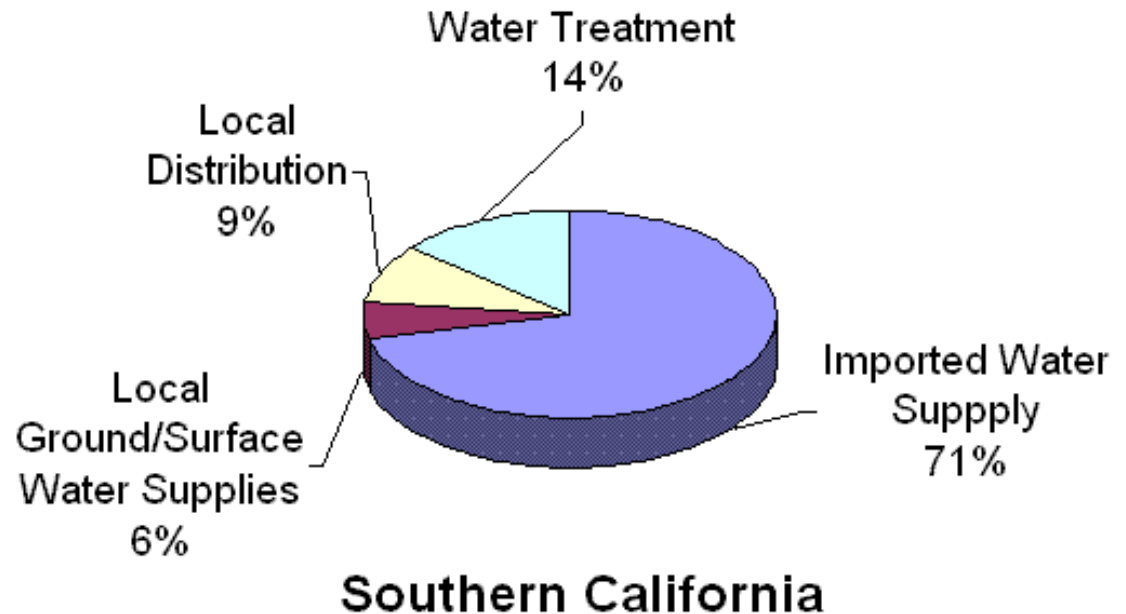
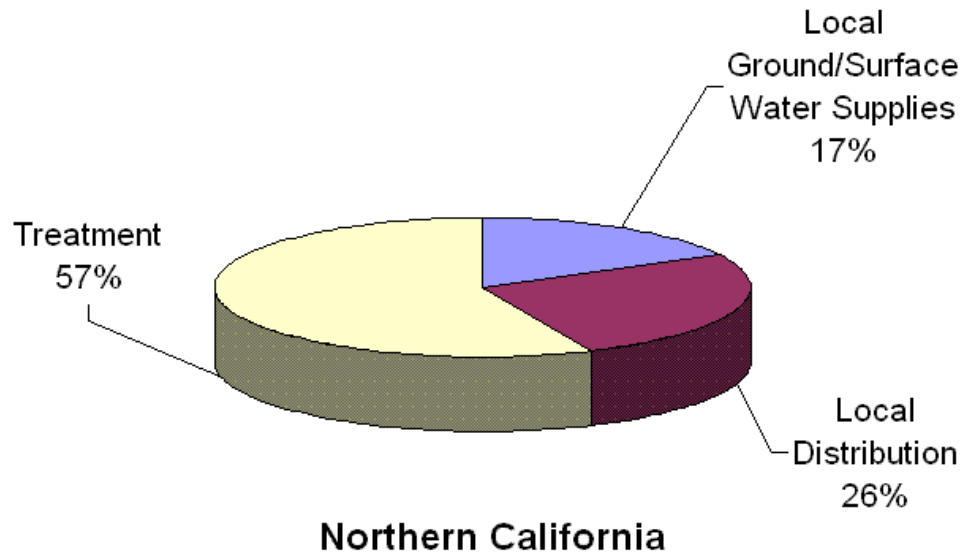

# Saline Water Resources in California

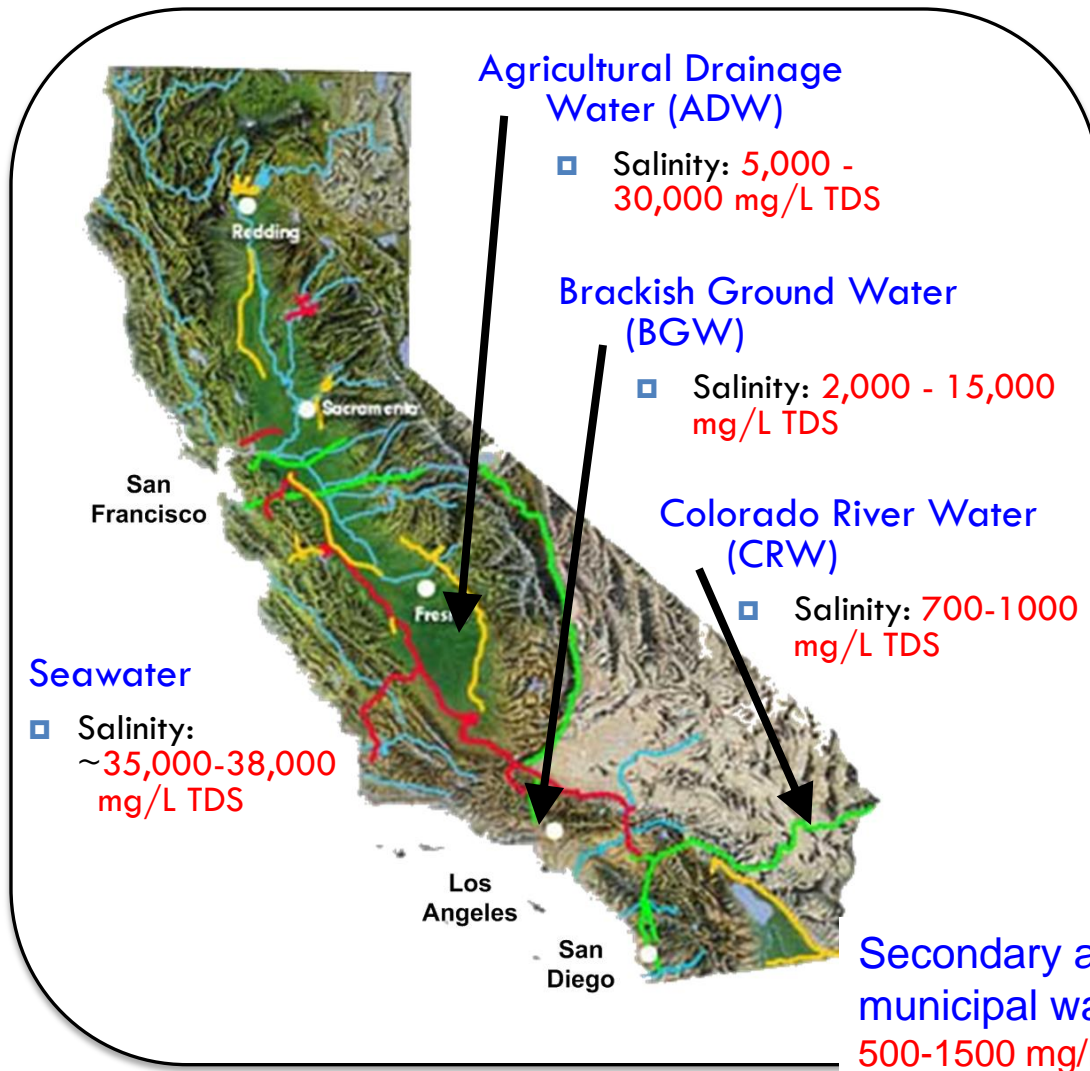

- Drought conditions and increasing population necessitate smarter water production and reclamation
- Opportunity to reclaim/produce water from several sources
  - Agricultural drainage water
  - Brackish groundwater
  - Seawater
  - Wastewater

# Establishing Water Policy and Technical Strategies is a Challenge due to Complex Water Pricing

Water Source/Customer	~\$/AF
Residential	400-900
MWD Water	366 – 811 <sup>#</sup>
CA Water Project <sup>(c)</sup>	20-300
SJV Agricultural Water	10 - 600
Desalted Seawater <sup>(b)</sup>	620 -1,200
Desalted Brackish Water <sup>(b)</sup>	200 – 600
MBR Treated Wastewater <sup>(b)</sup>	300 – 600
Bottled Water	~1x10 <sup>6</sup>

- (a) low-high estimate ; (b) – excludes conveyance; (c) – farming and urban
- Average price of consumer delivered water ~\$489/AF (AWWA)
  - The price of water in various CA locations can exceed the above estimates
  - # - replenishment untreated – full Service Treated
  - 1 AF = 325,851.4gallons, 1 U.S. Gallon=3.78 L

# Inland versus Seawater RO Desalination

## Brackish Water Desalination

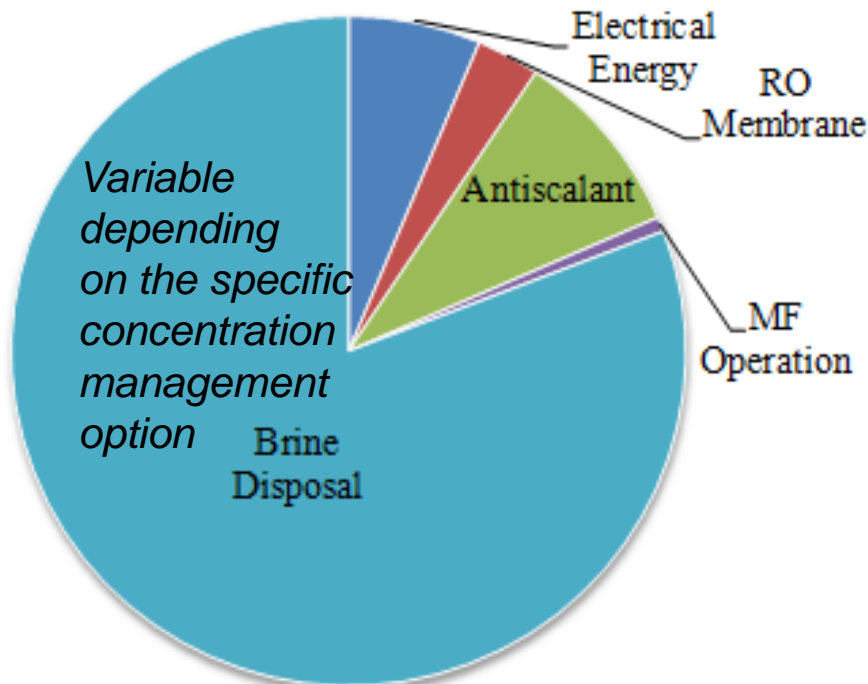

### Cost reduction potential:

- Increase recovery to minimize brine disposal/management costs
- Lower cost mitigation of mineral scaling/fouling

## Seawater Desalination

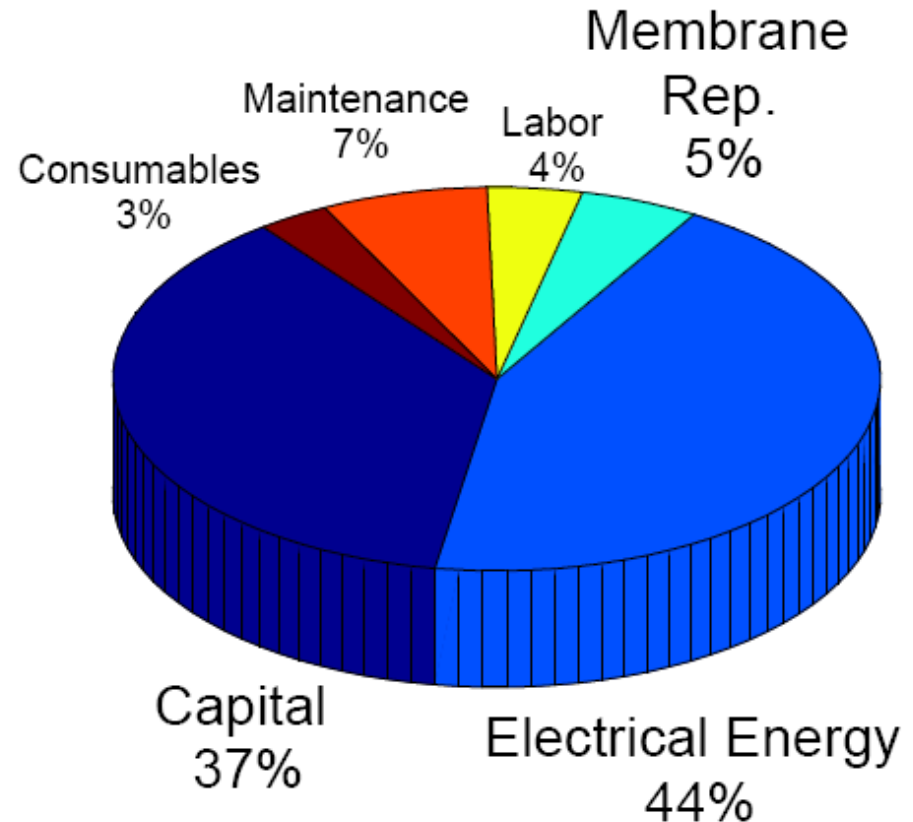

### Cost reduction potential:

- Energy
- Capital cost
- Maintenance/labor
- Membrane & consumables

# The Energy Cost of RO Desalination

Rate of pump work:  $\dot{W}_{pump} = \Delta P \times (Q_f - \eta_E Q_b) / \eta_p$

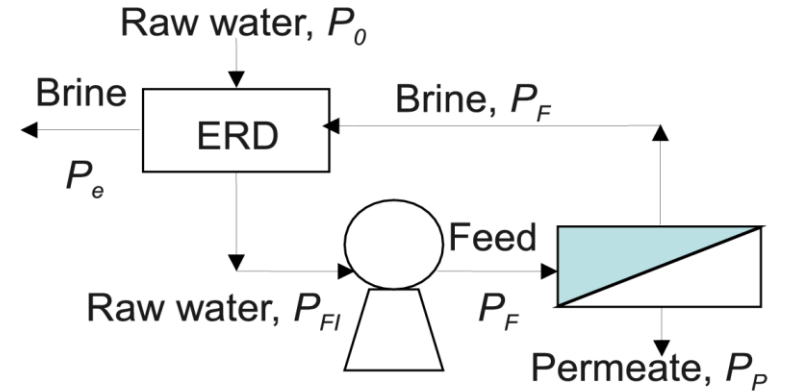

$$Q_p = A_m L_p (\overline{\Delta P}_m - \sigma \overline{\Delta \pi})$$

$$= A_m L_p (\overline{NDP})$$

TDS=35,000 mg/L

Global optimum:  $Y_{opt}=0.5$ :  
(w/o ERD)

$$SEC_{wo/ERD} = 3.2 \text{ kWh/m}^3$$

$$SEC_{w/ERD} = 1.6 \text{ kWh/m}^3$$

*Actual optimal recovery must consider O&M and capital costs*

## Ideal Normalized SEC Curves for Different Scenarios

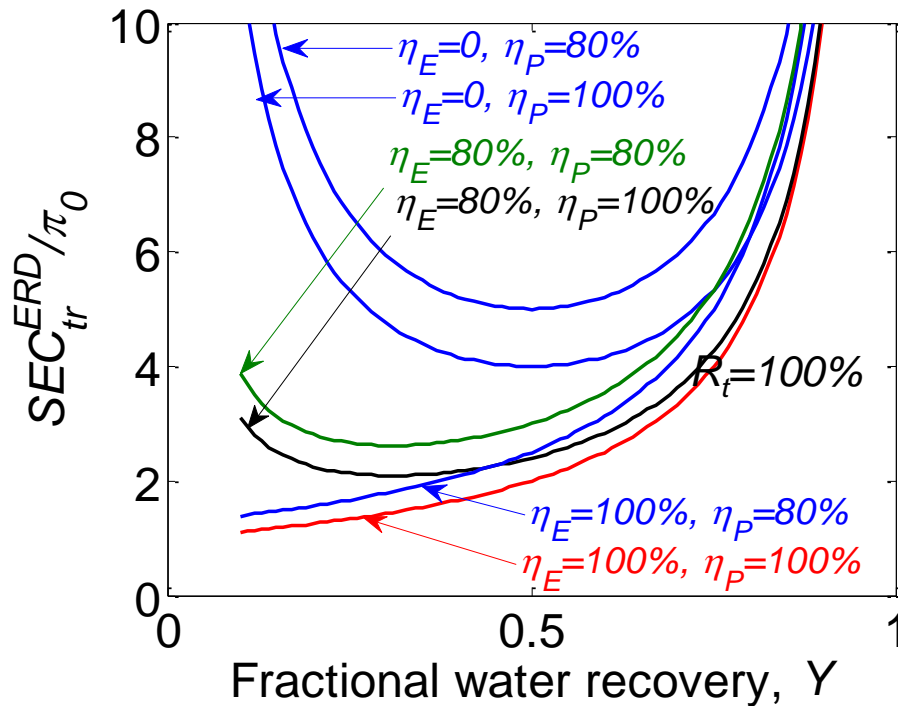

- At the thermodynamic restriction limit, the minimum applied pressure is a function of recovery and rejection ( $Y_t, R_t$ )
- When  $Y_t$  is small, more energy is wasted in the brine stream
- When  $Y_t$  is large, the required applied pressure increases rapidly

# Process Configuration for Reduced RO Energy Consumption

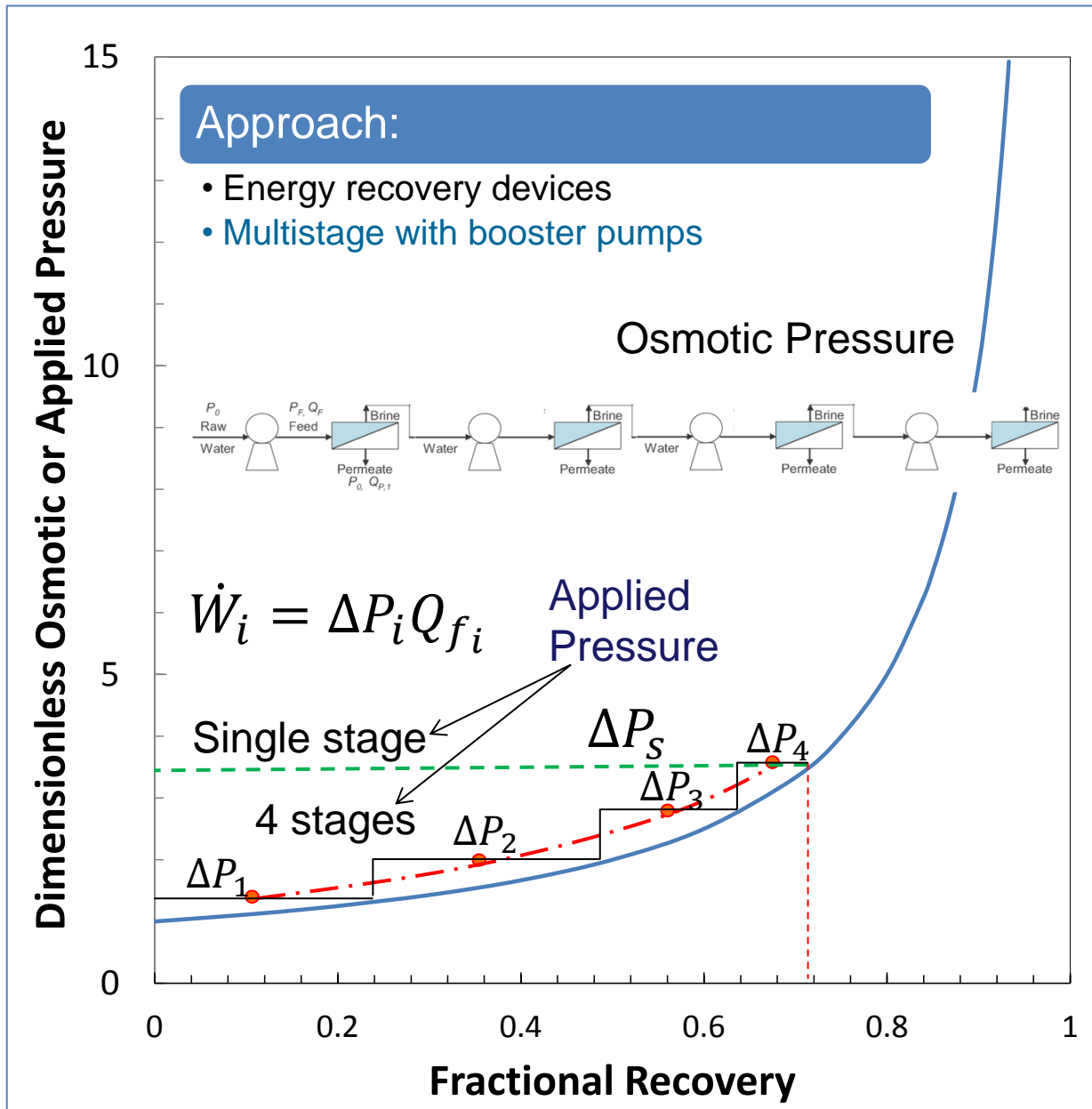

Reduce energy consumption via optimized RO process configuration to enable operation close to the osmotic pressure curve, e.g.,

- multi-stage RO

System Design will depend on the balance between reduction in energy consumption relative to increased capital cost



# Is Seawater Desalination Expensive?

**Example:** Assume water use of 150 gallons per household per day

Seawater desalination cost (high-end): ~12 kWh/1000 gallons → 1.8 kWh per day or ~657 kWh annually



Refrigerator energy use: 511 – 693 kWh annually



A/C Central daily average (based on 3 months use): 3 kWh per day  
42" Plasma TV: 219 kWh annually



1 Gallon of Gasoline: ~36 kWh  
2013 Chevrolet Volt requires 8.8 kWh/25 miles

# Centralized Water Systems

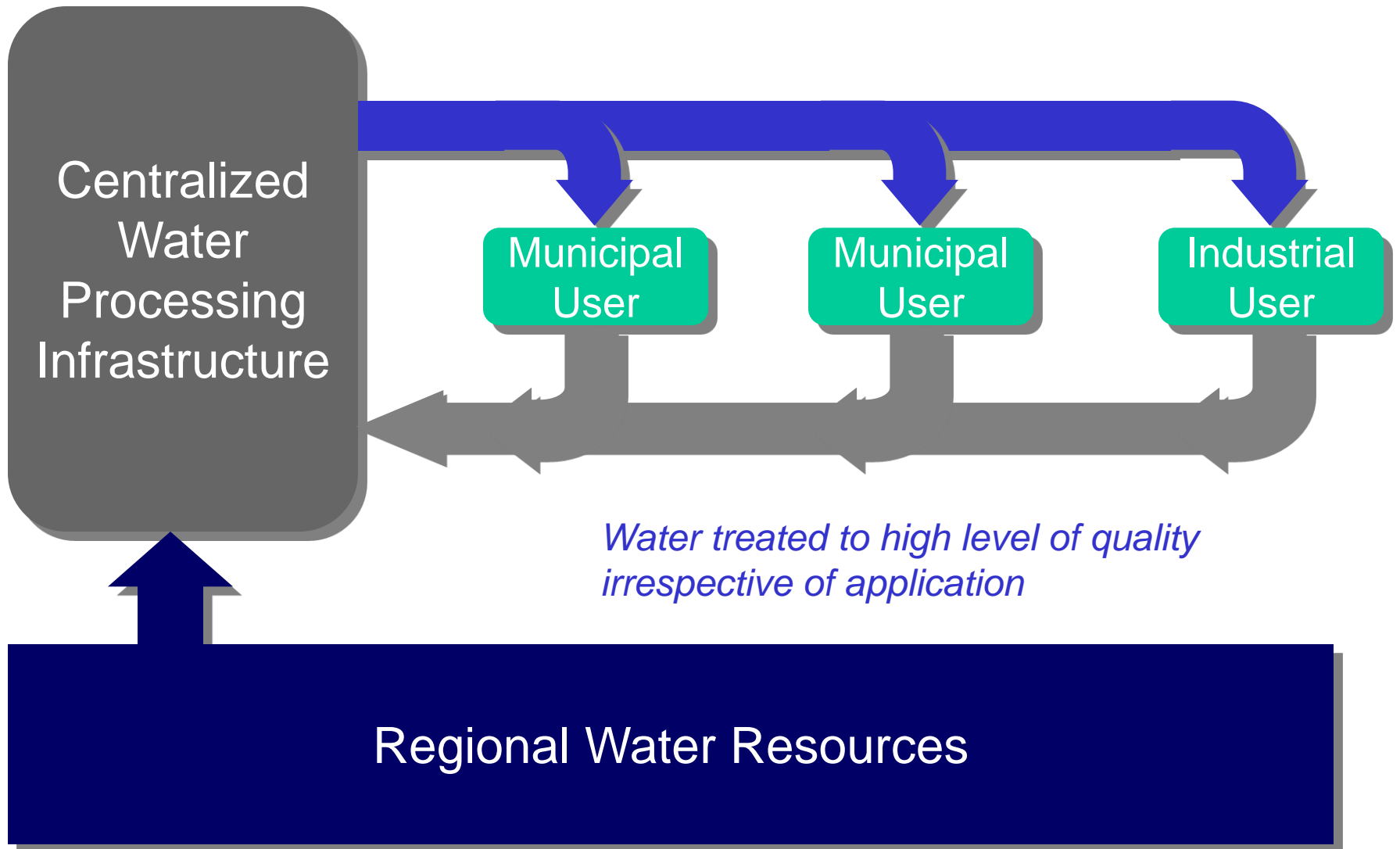



# Hyperion Treatment Plant

## Los Angeles, CA

Estimated upgrade costs :\$1.6B

Hyperion  
Treatment Plant



# Centralized Water Systems

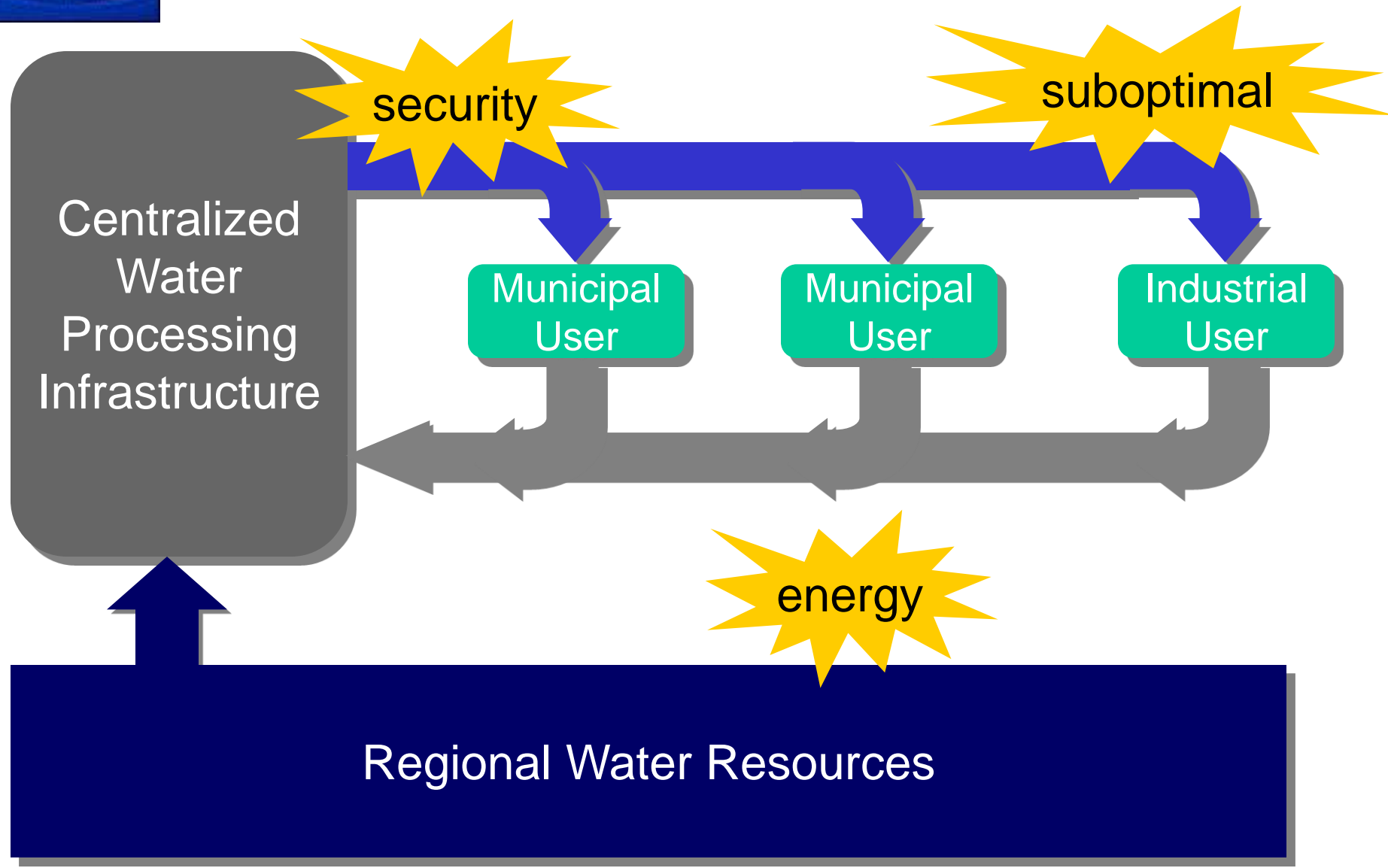

# Distributed Water Processing:

Water is needed at different levels of purity!

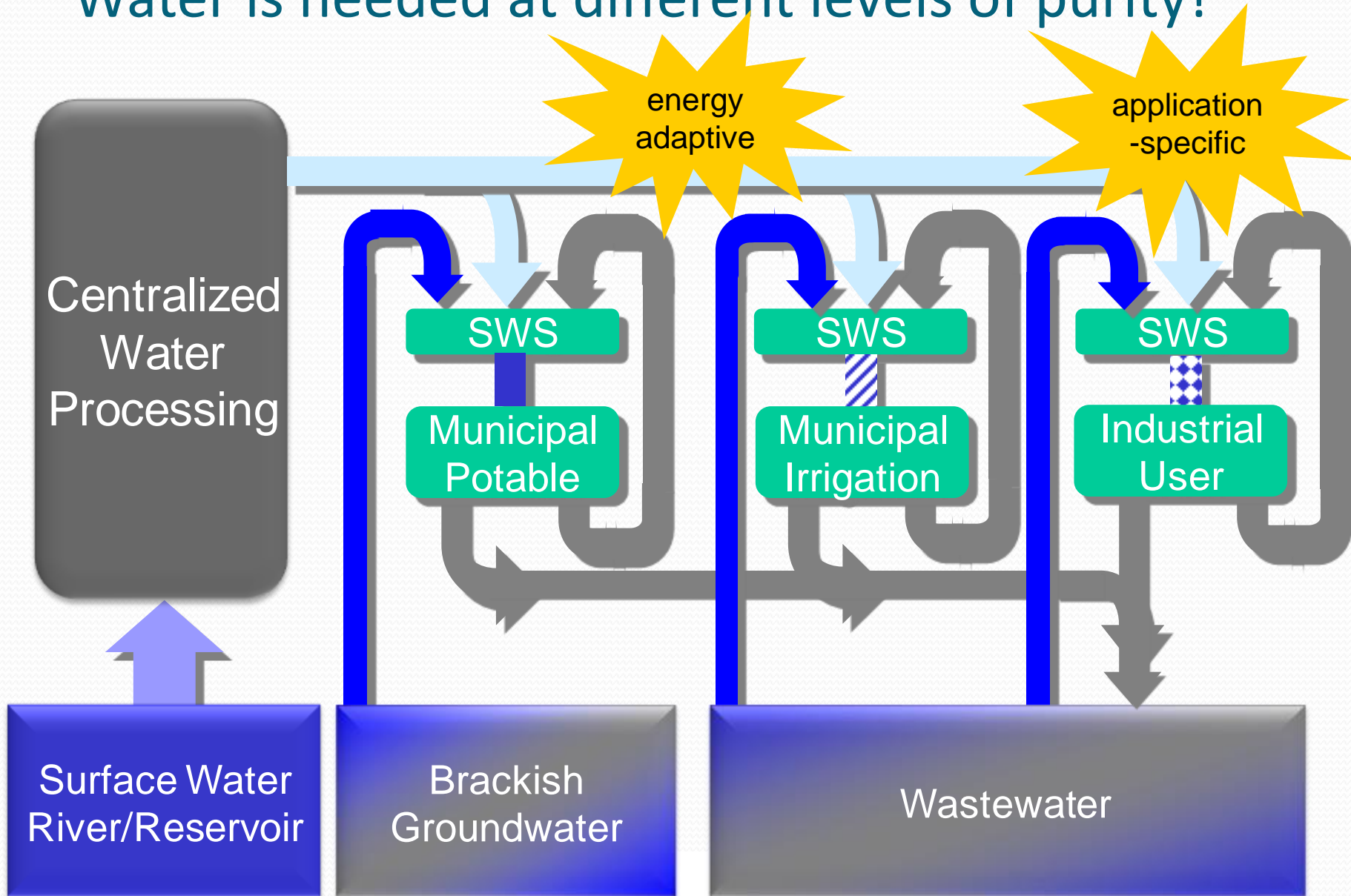

# Water Production, Conveyance and Wastewater Treatment : Distributed and Centralized Management

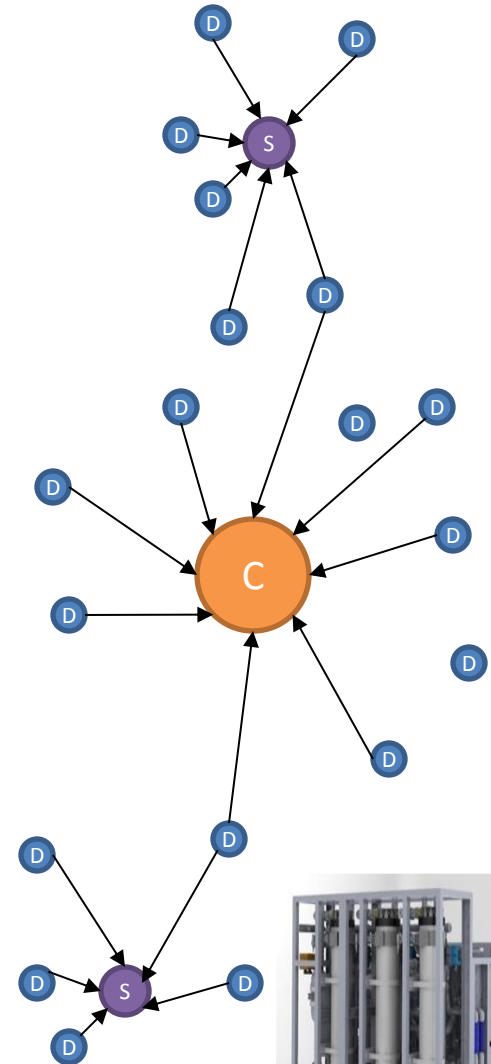
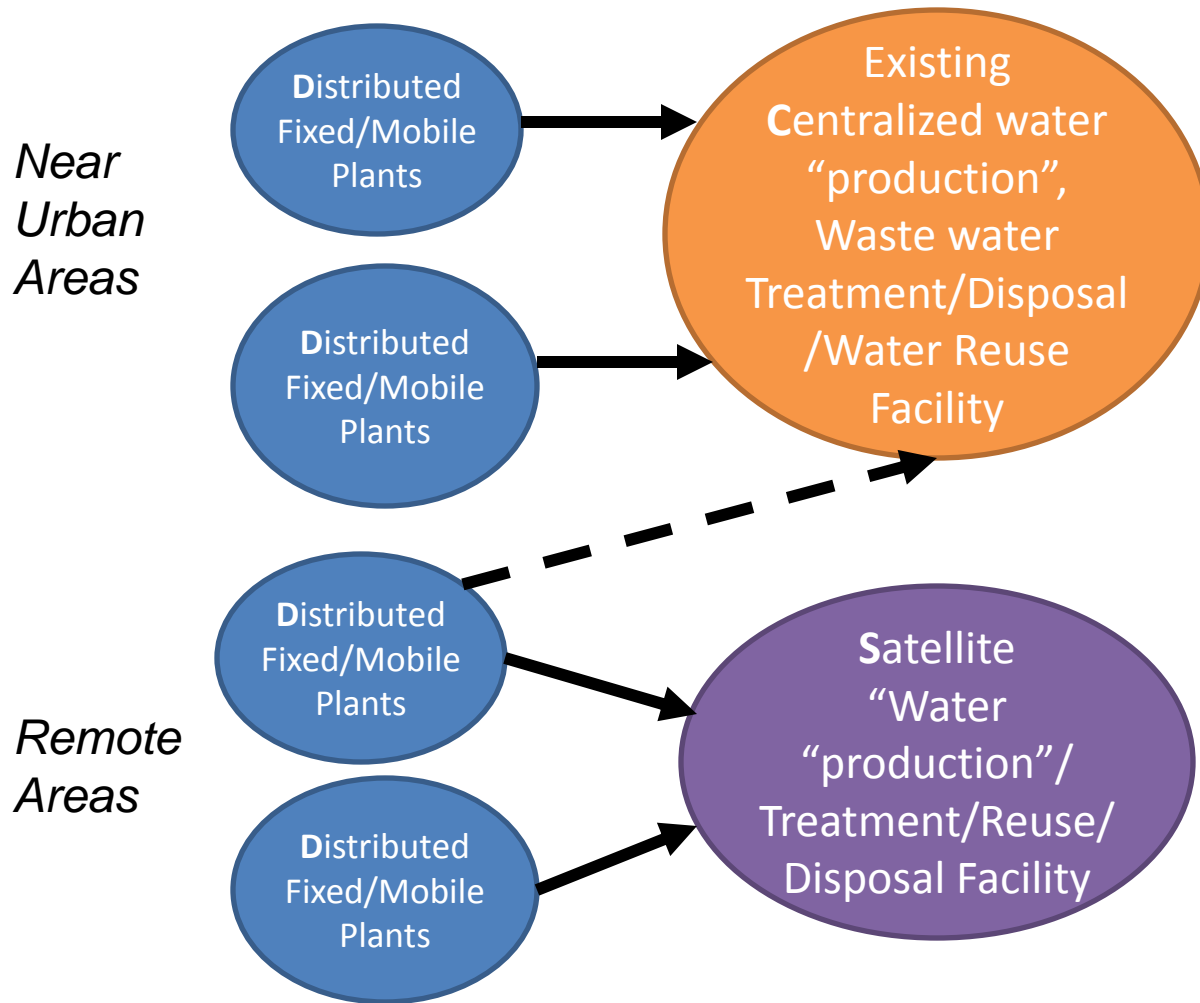

Augment with existing centralized or with satellite water infrastructure for distributed drinking water treatment/ wastewater management

# Distributed Water Network

- Water treatment near the “point-of-use “ and/or at the source
- Autonomous self-adaptive operation, advanced sensors, fault-detection
- Standardized modular systems
- Central supervisory system /cyberinfrastructure → “smart water systems”

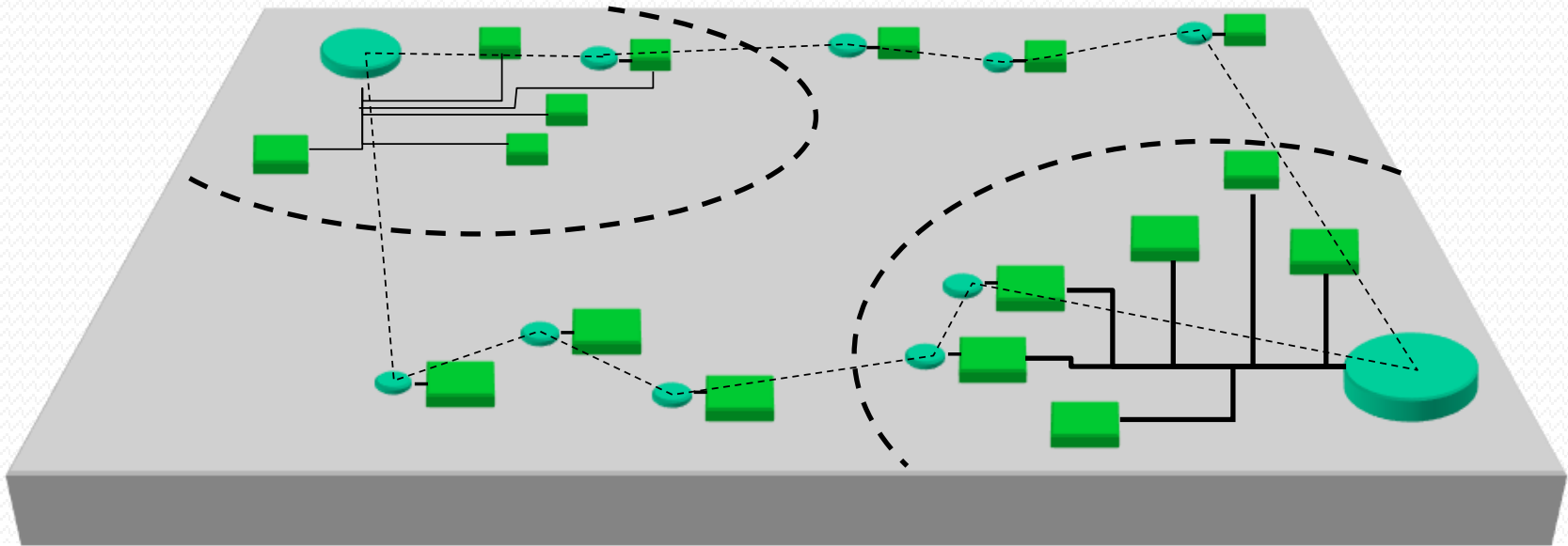

## Benefits:

- Reduce water consumption and increased use of underutilized water sources & reuse
- Lower capital investment relative to centralized infrastructure
- Treat water to the required purity level
- Serve remote communities and treat distributed impaired water sources
- Reduce energy cost associated with water conveyance & lower carbon foot print
- Enable integration of local renewable energy resources with water systems

# Augmenting Centralized Water Infrastructure with Distributed Water Systems

## A Shift in Water Resources & Management Paradigm

### Technical Challenges

- ❑ Self-adaptive operation
- ❑ Flexible system architecture of modular design & Standardization
- ❑ Advanced on-board control/monitoring systems
- ❑ Remote monitoring/control
- ❑ Energy optimal operation
- ❑ Fault-detection
- ❑ Real-time optimization w.r.t utilization of alt. energy sources (e.g., wind and solar)
- ❑ Cyberinfrastructure for remote centralized supervision

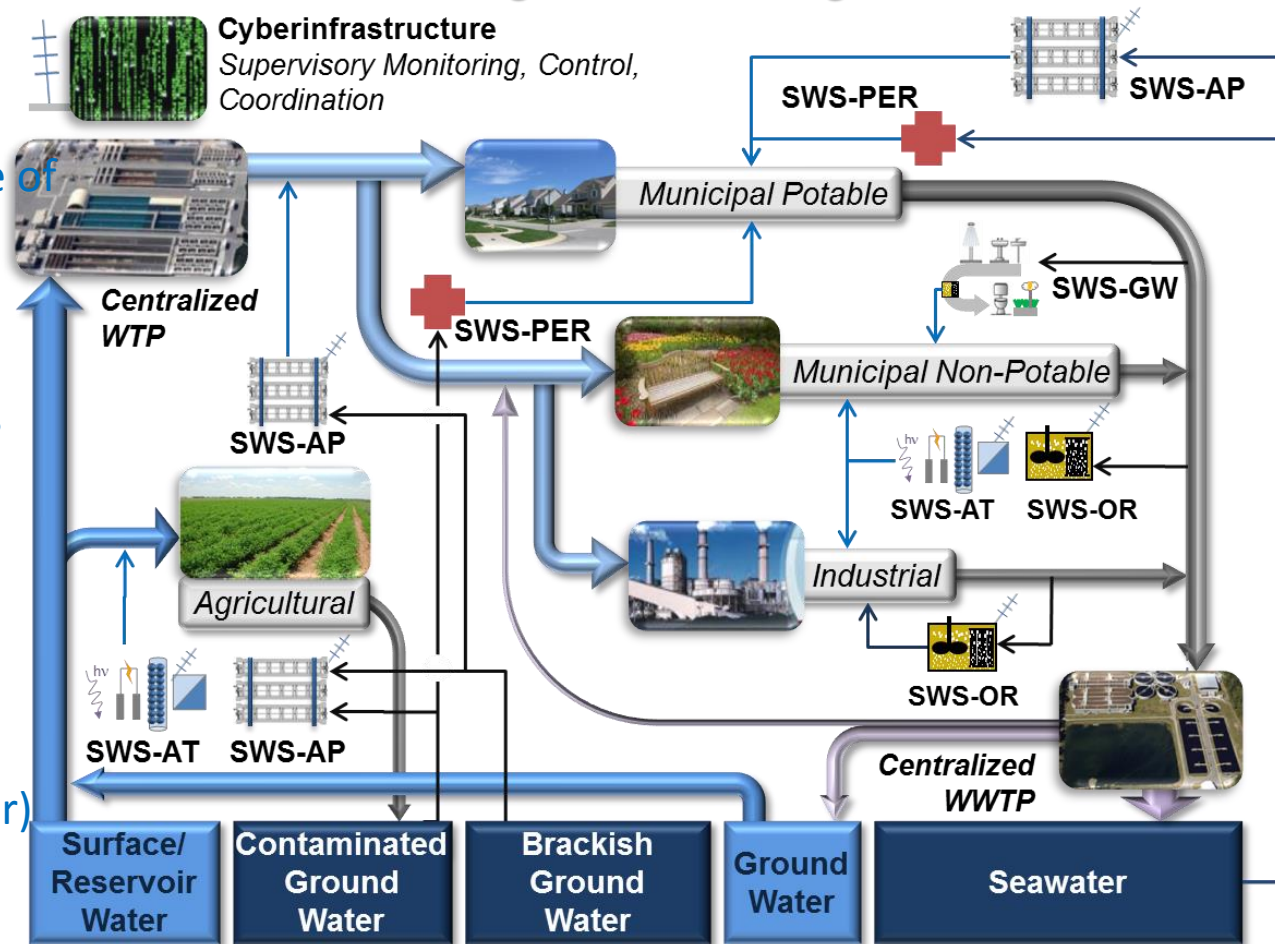

Technology Transfer: Fundamentals → Laboratory → Field



# UCLA SIMS Treatment and Recycling of Cooling Tower Blow Down Water at the UCLA Co-Gen Plant



- Process models
- Control and optimization
- Soft sensors
- Membrane characterization
- Software design
- Advanced system design concepts

- Disposal of up to ~66,000-152,000 gallons/day
- Water unit price= \$7.6/1000 Gallons
- 1,000-2,000 mg/L TDS
- Turbidity= 1.4-14 NTU
- Annual savings to UCLA ~\$90K





# UCLA COM2RO Smart Water System: Self-Adaptive MF/UF/O Operation and Compact system Design

US Navy base Port Hueneme, CA



*Permeate production capacity:*  
*Seawater: Up to ~18,000 GPD (69 m<sup>3</sup>/day)*  
*Brackish water: up to ~46,000 GPD (176 m<sup>3</sup>/day)*

*Water cost: ~ 0.55-1 /1000 m<sup>3</sup>*



Seawater  
Desalting:  
Onshore &  
shipboard



## COM2RO

- UCLA designed and built system operating (Since September 2010) at US Navy seawater desalination test facility at Port Hueneme
- Integrated self-adaptive operation of compact & modular UF-RO technology
- Operation without intermediate tanks (for RO feed or UF backwash)

Cohen et al, Patent Pending

# Wastewater Treatment and Reuse Applications

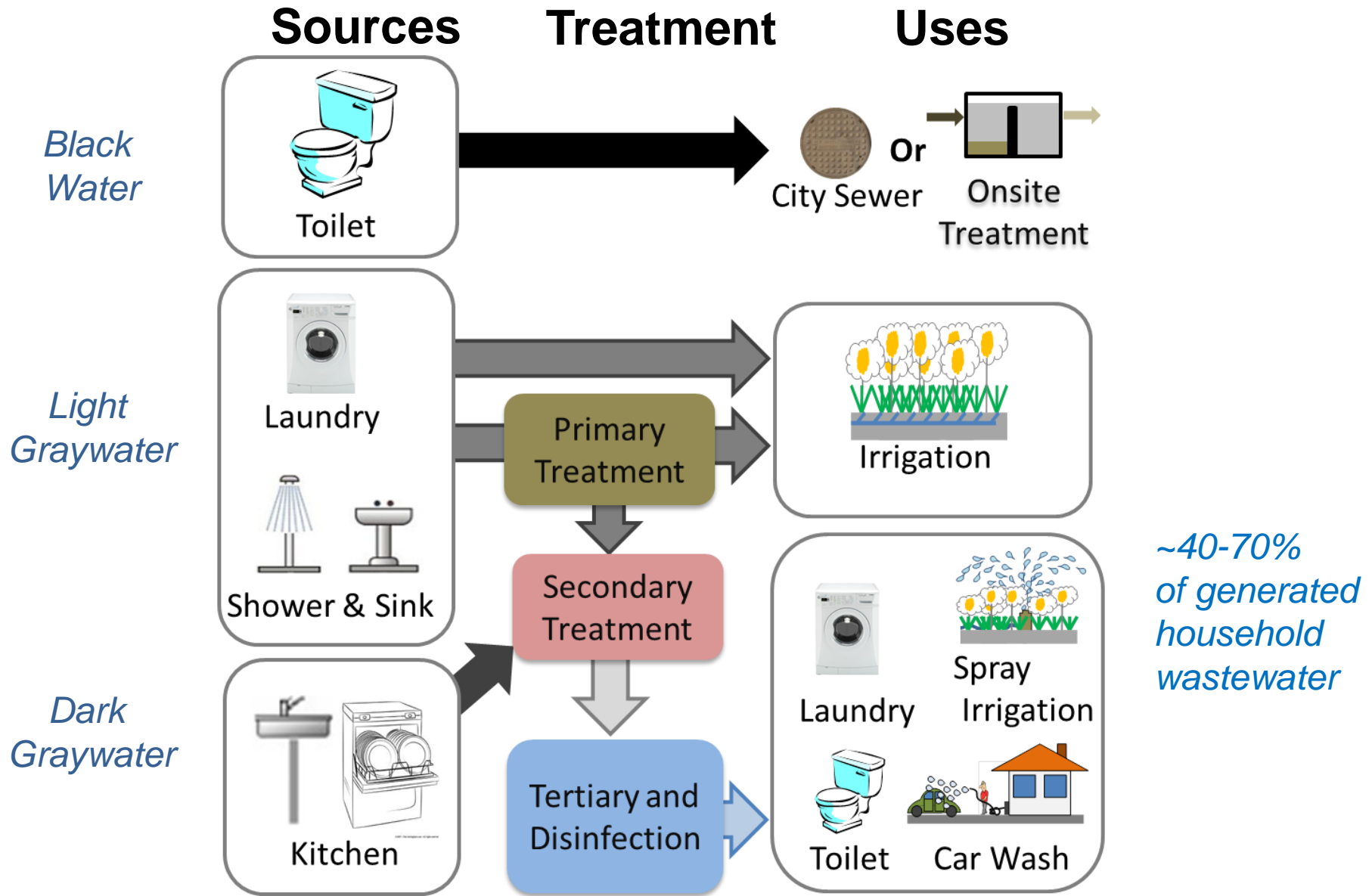

# UCLA Gray2Blue Vertical Wetland for Residential Graywater Treatment



Capacity:  
560 GPD

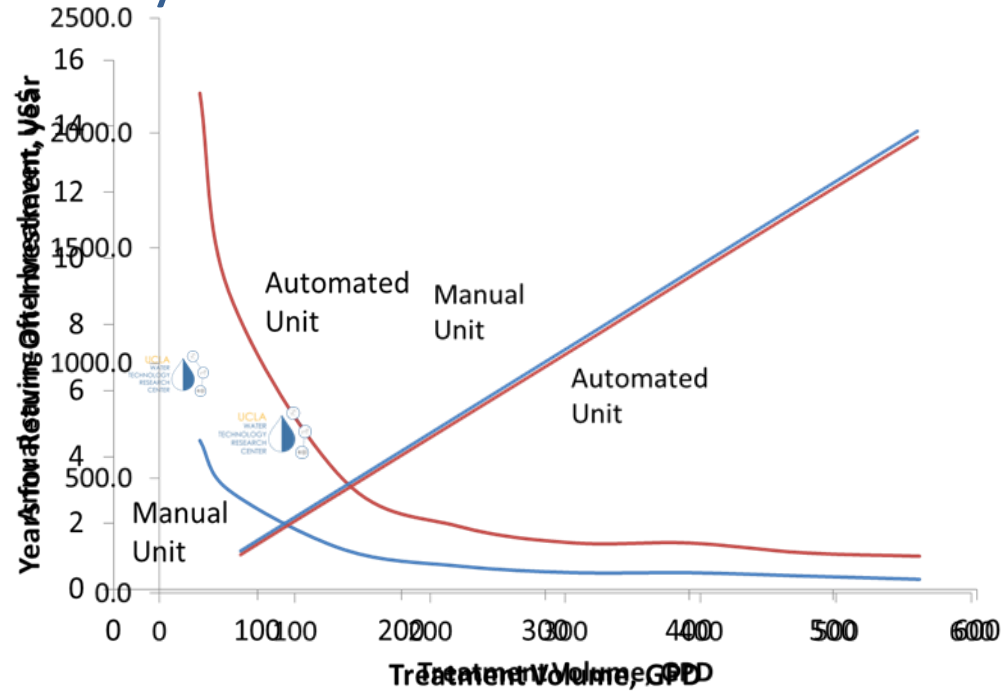

Serve a single residential or multiple neighboring homes

Low cost and low maintenance

Treat Graywater water to Title 22 for indoor use

Challenge: restrictive and conflicting regulations in the 50 States

# Modern Water Treatment Facilities make use of a Sophisticated Process Train

## Pretreatment

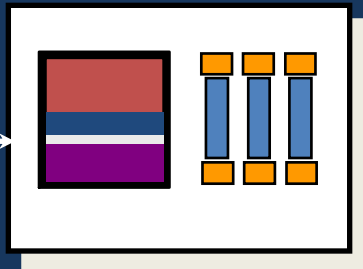

- Particle Removal
- Biofouling Control
- Disinfection
- Microorganisms
- Organics Removal

## Solute Rejection

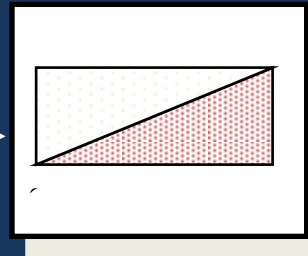

- Inorganics
- Organics
- Viruses
- Bacteria

## Membrane Concentrate

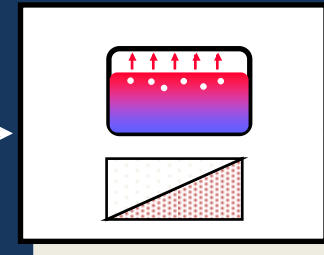

- Minimization
- Treatment
- Disposal

### Water Sources:

- ◆ Seawater
- ◆ Surface Water
- ◆ Groundwater
- ◆ Reclaimed Water
- ◆ Agricultural Drainage Water

### Product Waters:

- ◆ Potable Water
- ◆ Industrial Water
- ◆ Irrigation Water
- ◆ Agricultural Water

- *Modern MWT plants require significant energy (e.g., conveyance, mixing and aeration)*
- *Opportunities exist for increased level of energy/resource recovery*

# Modern Water Treatment Facilities make use of a Sophisticated Process Train

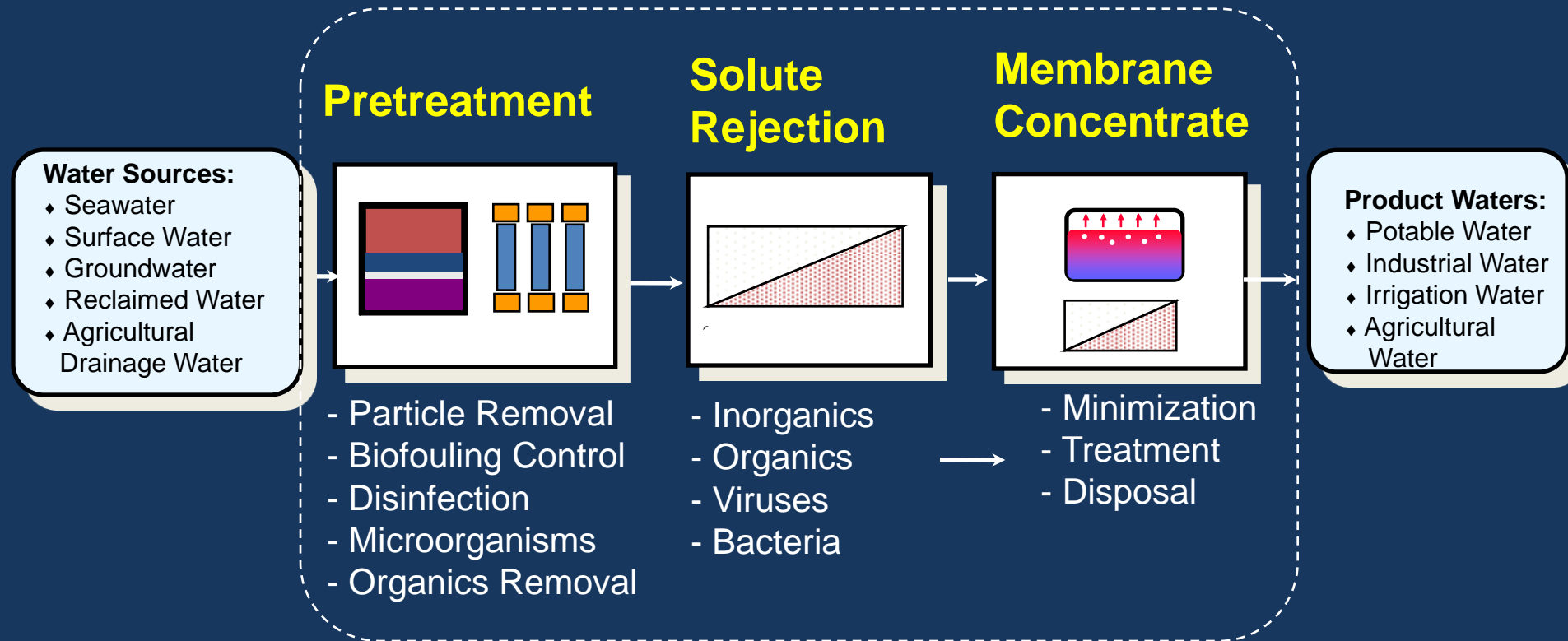

- *Current membrane-based water treatment processes lack robust control, automation and advanced process monitoring to deal with the variability of feed water quality, fouling and scaling, real-time optimization for energy minimization & reasonable cost ZLD for inland water*

# Distributed Water Treatment/Desalination Technologies: R&D Needs

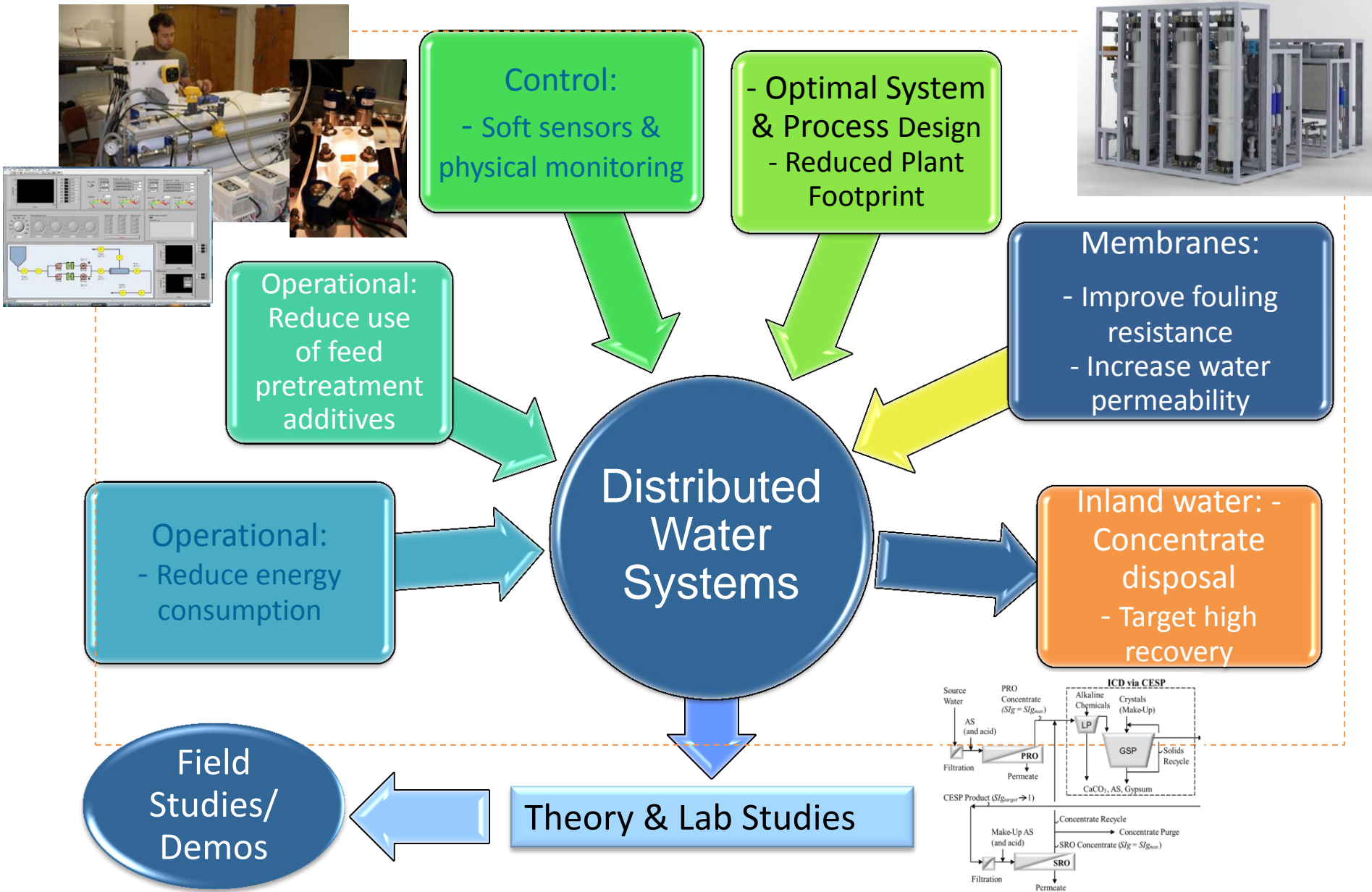

$$[\text{CO}_3^{2-}]_e = [\text{TC}]_e \cdot K_{a1} \cdot K_{a2} / ([\text{H}^+]_e^2 + K_{a1} \cdot [\text{H}^+]_e + K_{a1} \cdot K_{a2})$$

$$\phi(t) = \frac{\sum_{i=1}^{m \times n} 1 - \exp\left(-J_{N,i} \frac{\pi}{3} k_{\xi,i} t^3\right)}{m \cdot n}$$

$$\bar{N}(t) = \hat{J}_N \int_0^t (1 - \phi(t')) dt'$$

$$P(k, J_N) = \frac{(J_N \Delta t)^k e^{-J_N \Delta t}}{k!}$$

$$\bar{U} \cdot \nabla C = \nabla \cdot D \nabla C$$

$$FD = 1 - \frac{Q}{Q_0} = 1 - \frac{\left( \iint_f J_f dA + \iint_s J_s dA \right)}{\iint_o J_o dA}$$

# QUESTIONS?

$$\bar{U} \cdot \nabla (\rho \bar{U}) = -\nabla p + \nabla \cdot \eta \nabla \bar{U}$$

$$\frac{dr}{dt} = k_v' \frac{K_{sp}}{\gamma_{\text{Ca}^{2+}} (\text{SO}_4^{2-})} (SI_{\xi} - 1)$$

$$J_N = A_N \exp\left(-\frac{FV_m^2 \sigma^3 f(\theta) N_a}{(RT)^3 (\ln(SI))^2}\right) = A_N \exp\left(-\frac{a_N}{(\ln(SI))^2}\right)$$

$$X_{Ca} = \frac{1}{2} \left( (\Gamma_i + 1) - \sqrt{(\Gamma_i + 1)^2 - 4 \cdot \left( \Gamma_i - \left( \frac{K'_{CaCO_3}}{K_{a2}} \cdot \left( \frac{[\text{H}^+]_e^2}{K_{a1}} + [\text{H}^+]_e \right) + K'_{CaCO_3} \right) / [\text{Ca}^{2+}]_i^2} \right)} \right)$$



# Energy Production from Salinity Gradients: Pressure Retarded Osmosis

## Energy Production:

$$E_{PRO} = \overline{J_v A \Delta P_m} = A L_p \overline{(\sigma \Delta \pi - \Delta P_m) \Delta P_m}$$

Maximum energy production

$$\Rightarrow \frac{\partial E}{\partial \Delta P_m} = 0$$

Approximate analysis based on average flux and osmotic pressure

$$(\Delta P_m)_{\max} = \frac{1}{2} \Delta \pi$$

$E_p$  - Additional pumping energy for feed water and for conc draw from the source to the plant.

$$(E_{\max})_{\text{net}} = \frac{A L_p}{2} (\Delta \pi)^2 \left( \sigma - \frac{1}{2} \right) - Q_{df} \Delta P_{df} - E_p$$

Osmotic energy production (ideal when  $\sigma=1$ )

Pumping energy of draw solution

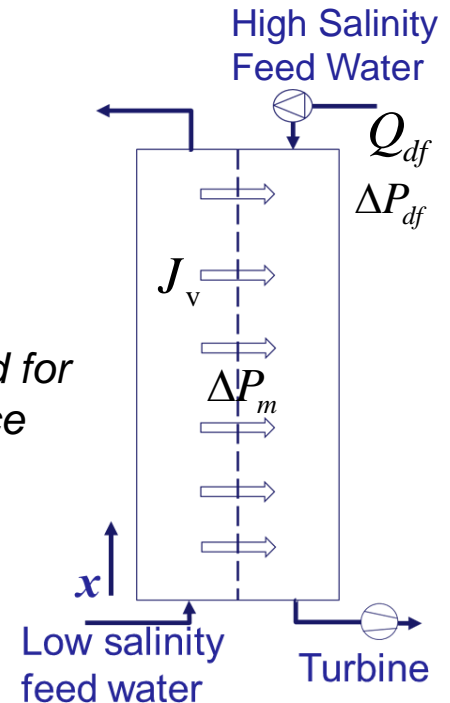

Reported  $E_{\max}$ :  
~ 1.3-10 w/m<sup>2</sup>

## Opportunities for PRO?

- Locations where the draw sol'n salinity is >> seawater salinity
- Co-location of RO/FO/PRO plants & wastewater plants

# Water Source-Supply Management

- The water balance:

$\alpha$  = Rate of change of water storage =  
Water input/capture (natural + reclaimed water recharge) –  
water loss (natural + usage)

Water sustainability requires that  $\alpha \geq 0$

## Water-side solution to the Water-Energy Nexus:

- Reduce water use
  - Water use efficiency, water conservation
- Develop new water sources for potable and non-potable use
  - Reclaimed municipal, industrial, agricultural water sources
  - Upgrade unused/impaired water sources
  - Decrease both the energy and capital cost of water desalination
- Utilize renewable energy sources
- Environmental stewardship

# Oil & Gas: Produced Water

- > 15 billion barrels of water produced with oil and gas each year, (~9.5 barrels of water per barrel of oil)
- Produced water quality can vary with respect to “water quality” (e.g., salinity and composition of inorganic ions, hydrocarbons, temperature and pH)
- Treatment and disposal costs
- Potential impact of surface discharge on vegetation, soil and streams
- Can treated produced water become a valuable resource?
- Constraints on Coal Bed Natural Gas Production due to environmental concerns w.r.t produced water



# Reducing Water Related Energy Use

- Distributed smart (self-adaptive) water systems for water treatment and production

## Renewable Energy for water treatment/production:

- Solar powered desalination
- Water disinfection using solar radiation
- Mechanical wind pumps (windmills)
- Energy from biomass (e.g., Biodiesel)
- Coupling of geothermal energy with water production
- Wave energy for water production (desalination)

## Use of Waste heat:

- Desalination, disinfection, organic destruction

# Process Control for Self-Adaptive Operation

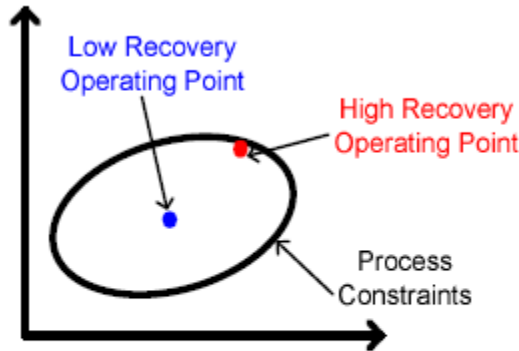

Operation close to process constraints

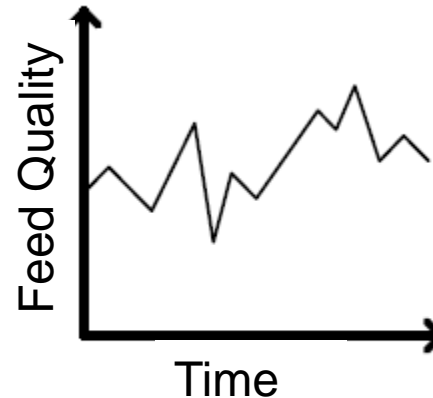

Feed water variability with time

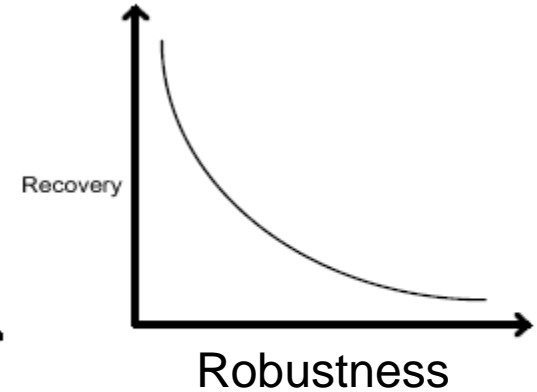

Robustness margin significantly reduced

- Model based approach to controller design

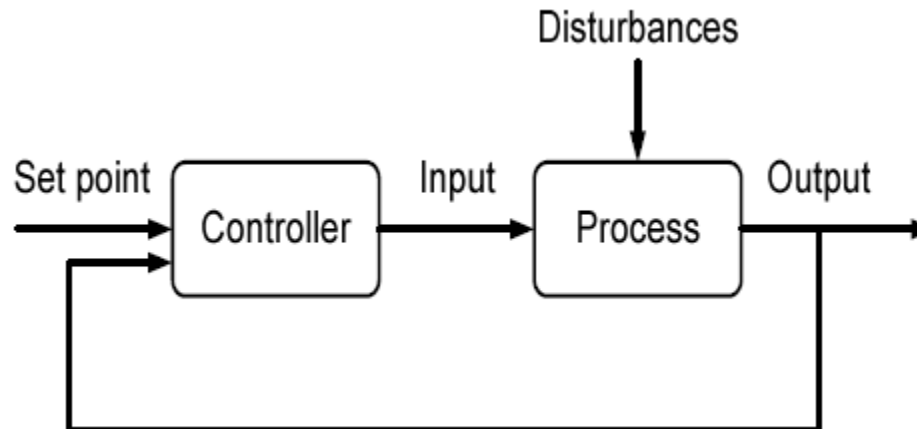

# BUILDING A WORLD OF DIFFERENCE

11 June 2013

## DEVELOPING SUSTAINABLE ENERGY SOLUTIONS IN THE WATER INDUSTRY

**RALPH T. EBERTS**

EXECUTIVE VICE PRESIDENT  
BLACK & VEATCH

NFS EWN Workshop June 2013



**BLACK & VEATCH**  
Building a world of difference.®

# TODAY'S GLOBAL WATER INDUSTRY DRIVERS



- **Population Growth**
- **Urbanization**
- **Aging Infrastructure**
- **Water Scarcity**
- **Climate Change**
- **Lack of Funding**

# FUTURE STATE OF WATER INDUSTRY



- **Embedded into Urban Planning**
- **Sustainable solutions**
- **Diversification of supplies**
- **Resilient infrastructure**
- **Integrated into Liveable Cities**



# CREATE RESOURCE RECOVERY PLANTS

- Paradigm shift from waste to recovery
- Business case to balances resource supply and demand
- Recovery of energy, water, solids, and nutrients

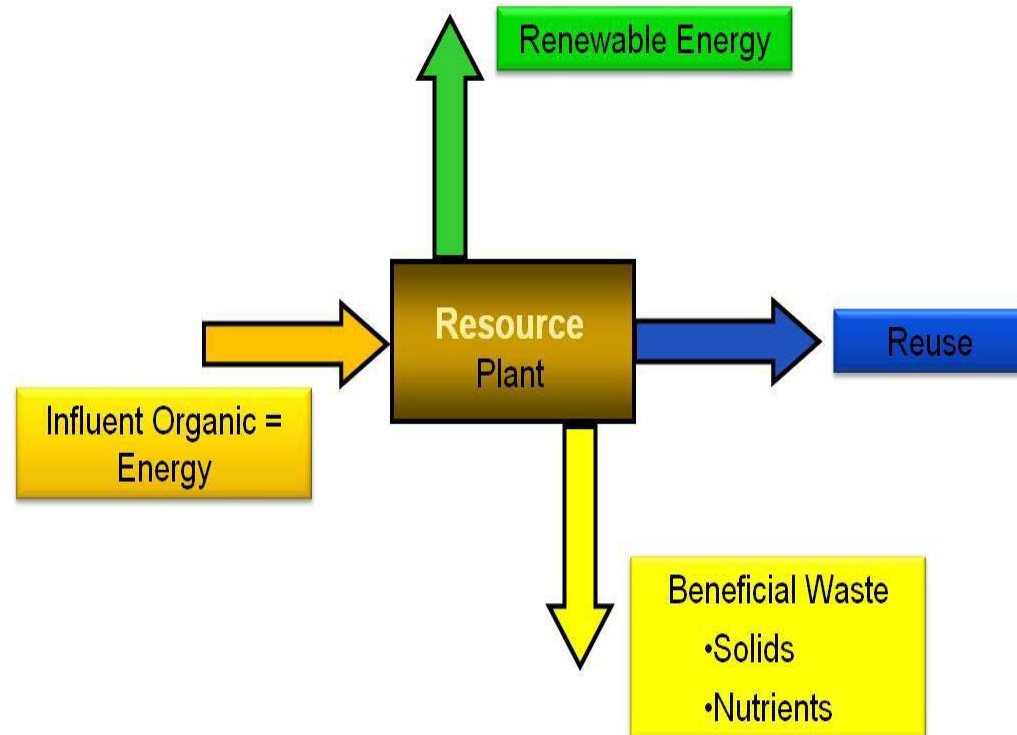

# NEXUS OF WATER AND ENERGY

## ENERGY EFFICIENCY, GENERATION OR RECOVERY PROGRAMS

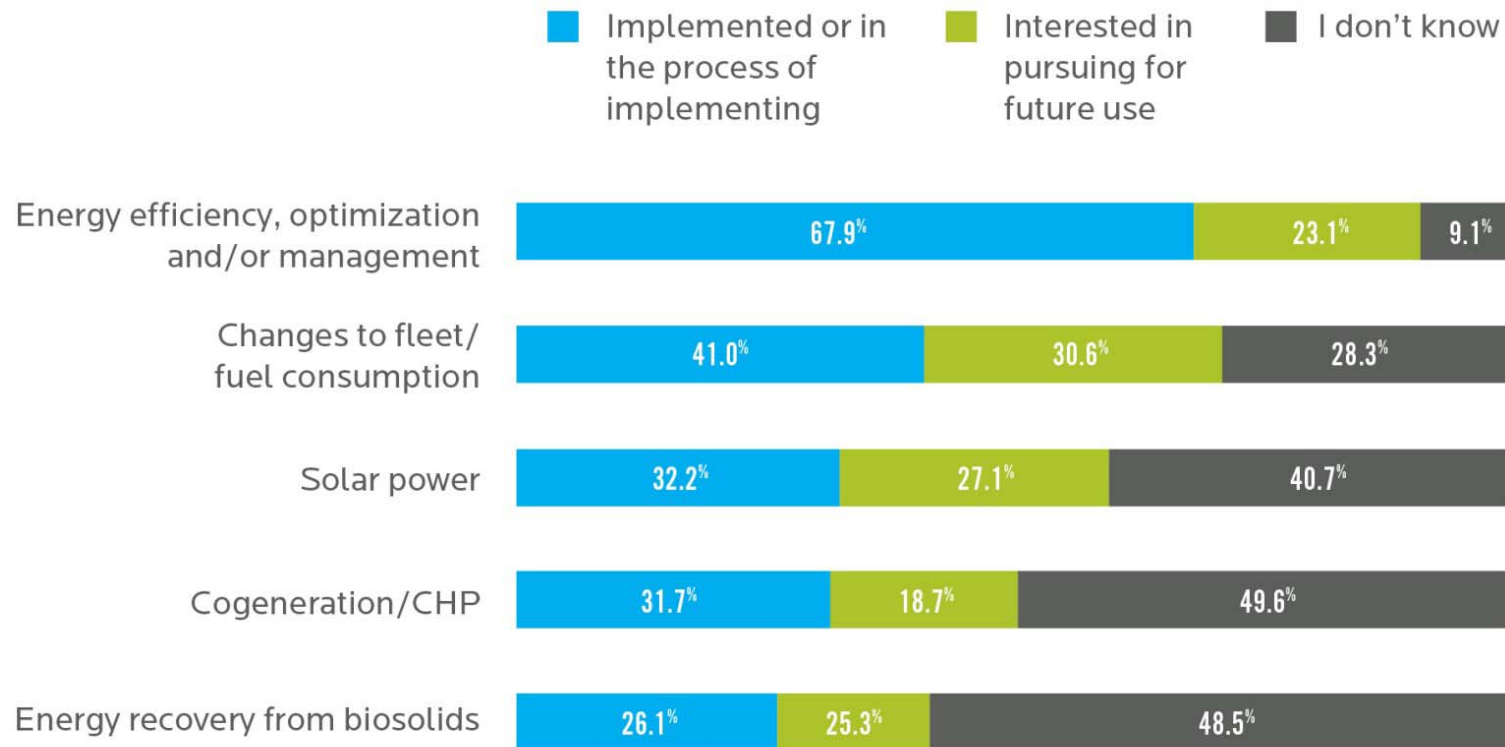

**Significant opportunities exist to not just reduce energy consumption, but to recover energy**

# COMBINE RENEWABLES AND WATER TREATMENT SYSTEMS



- **Pressure to Innovate**
- **Desire to be Green**
- **Drive to Energy Neutrality**

**Thames Beckton Water Treatment Plant**

# LOS ANGELES DIGESTER GAS UTILIZATION PROJECT



- Renewable energy source produced through treatment of wastewater
- Third party solutions driven by innovation
- Effectively closes water and energy cycles

**Digester facility at Hyperion Treatment Plant**

# SINGAPORE

## 70 MGD TUAS DESAL DBOO

CLIENT: PUBLIC UTILITIES BOARD (PUB), SINGAPORE

- 70 MGD (318 MLD) seawater desalination plant in Singapore
- Design-Build-Own-Operate (DBOO) Project Delivery
- Facility adjacent to SingSpring Desalination Plant



# SINGAPORE 70 MGD TUAS DESAL DBOO

CLIENT: PUBLIC UTILITIES BOARD (PUB), SINGAPORE

- Hyflux Ltd identified as Preferred Bidder
- First Year Tariff = S\$0.45/m<sup>3</sup>
- Solution included power plant adjacent to desal plant
- Water Purchase Agreement signed 6 April 2011
- Opening ceremony scheduled for September 2013



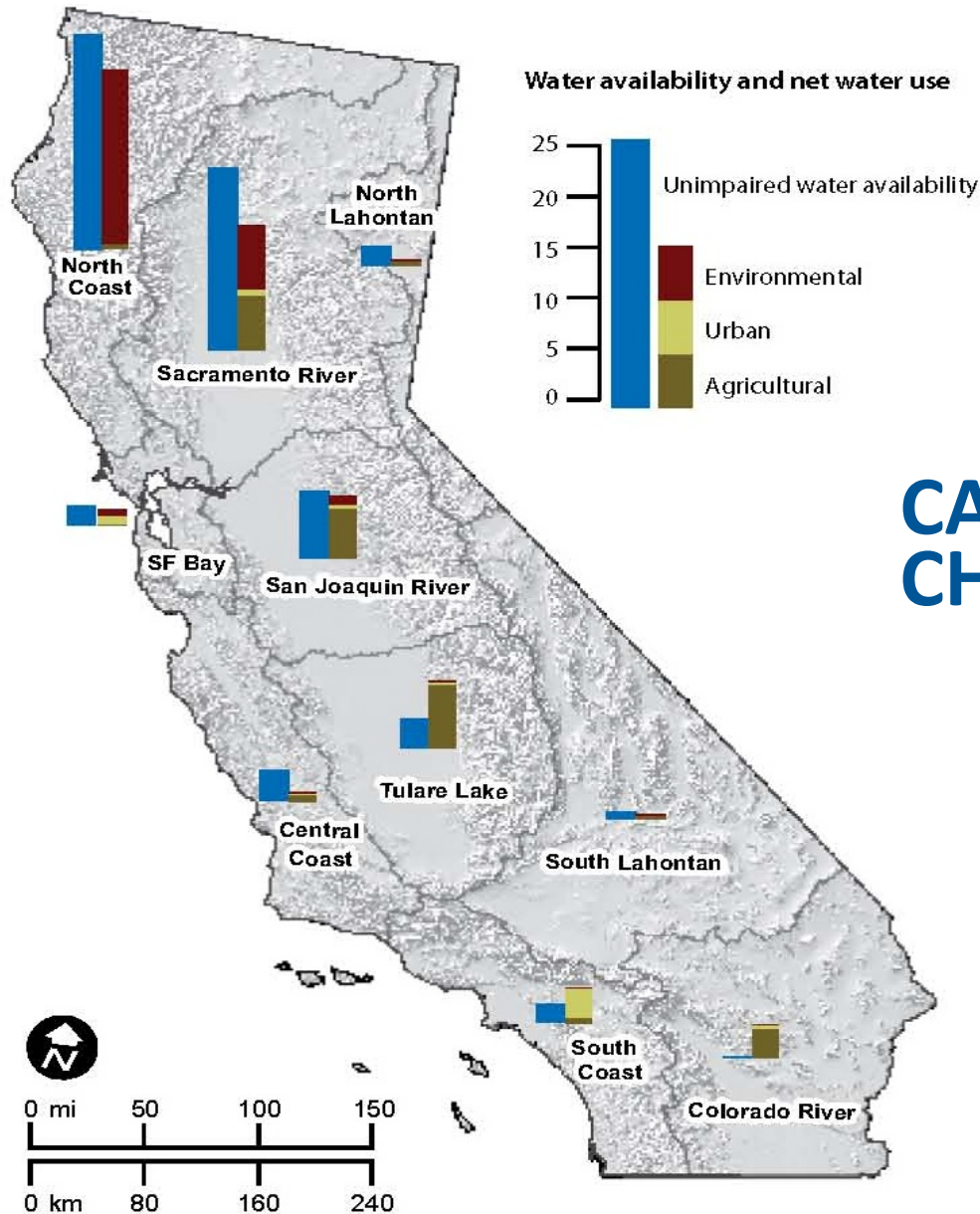

# CALIFORNIA'S WATER CHALLENGE

- Supply vs. Demand
- Seismic activity
- Cost to convey

SOURCE: California Department of Water Resources, *California Water Plan: Update 2009*, Bulletin 160-09.

NOTE: The map shows annual average values for 1998–2005 in millions of acre-feet.

# SINGAPORE - SIEMENS ED-CEDI DESALINATION TECHNOLOGY



- Low-energy seawater desalination project involving a combination of electro dialysis (ED) and continuous electrodeionization (CEDI).
- Commenced R&D efforts in Singapore on 1 October 2008
- Target energy consumption of 1.5 kWh/m<sup>3</sup>
- Composite average power consumption from January-April 2011 was recorded as 1.8 kWh/m<sup>3</sup>



# SMART UTILITY IS A JOURNEY

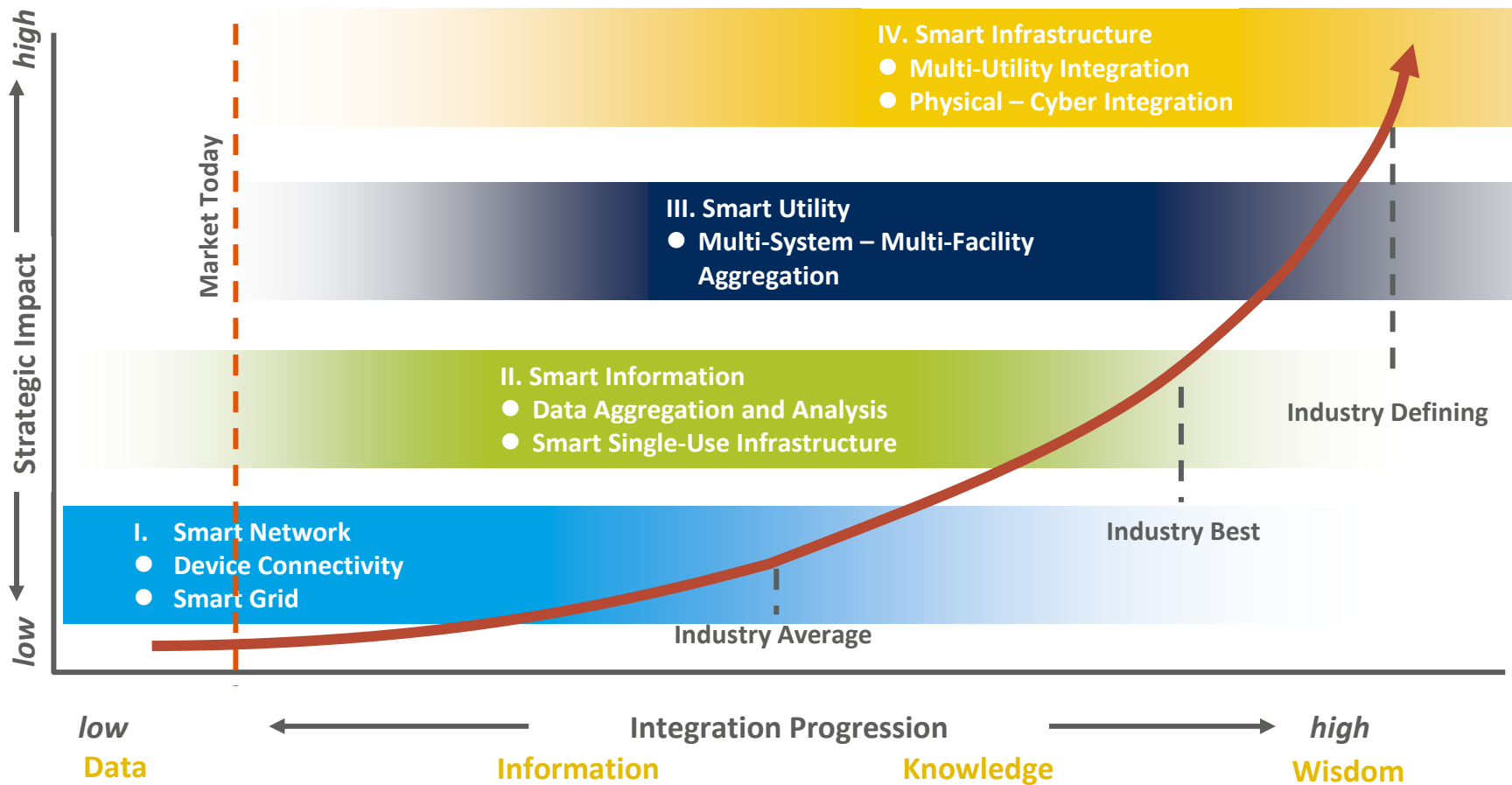

# NEW TREATMENT TECHNOLOGIES



- Membrane based
  - RO membrane based processes
    - Nano materials
    - Forward osmosis
    - Biomimetic membranes
  - Ceramic Membranes
- Electrodialysis & Electodeionization based processes
  - Electrical potential driven
  - Salinity gradient driven

# DEMONSTRATION PLANT AT CCK WTW, SINGAPORE



Source: R&D Team, PWN Technologies

- PWN Technologies, Netherlands & PUB Singapore
- 3 MLD capacity
- Key Objectives
  - Evaluate Flux (maximize to reduce capital costs)
  - Evaluate chemical cleaning frequencies (optimize to minimize recurrent costs)
  - Influence of ozone on membrane performance

# CONCENTRATE MANAGEMENT OPTIONS

- Direct discharge to surface water
- Discharge to POTW
- Underground injection
- Zero Liquid Discharge.

# CONCENTRATE MANAGEMENT

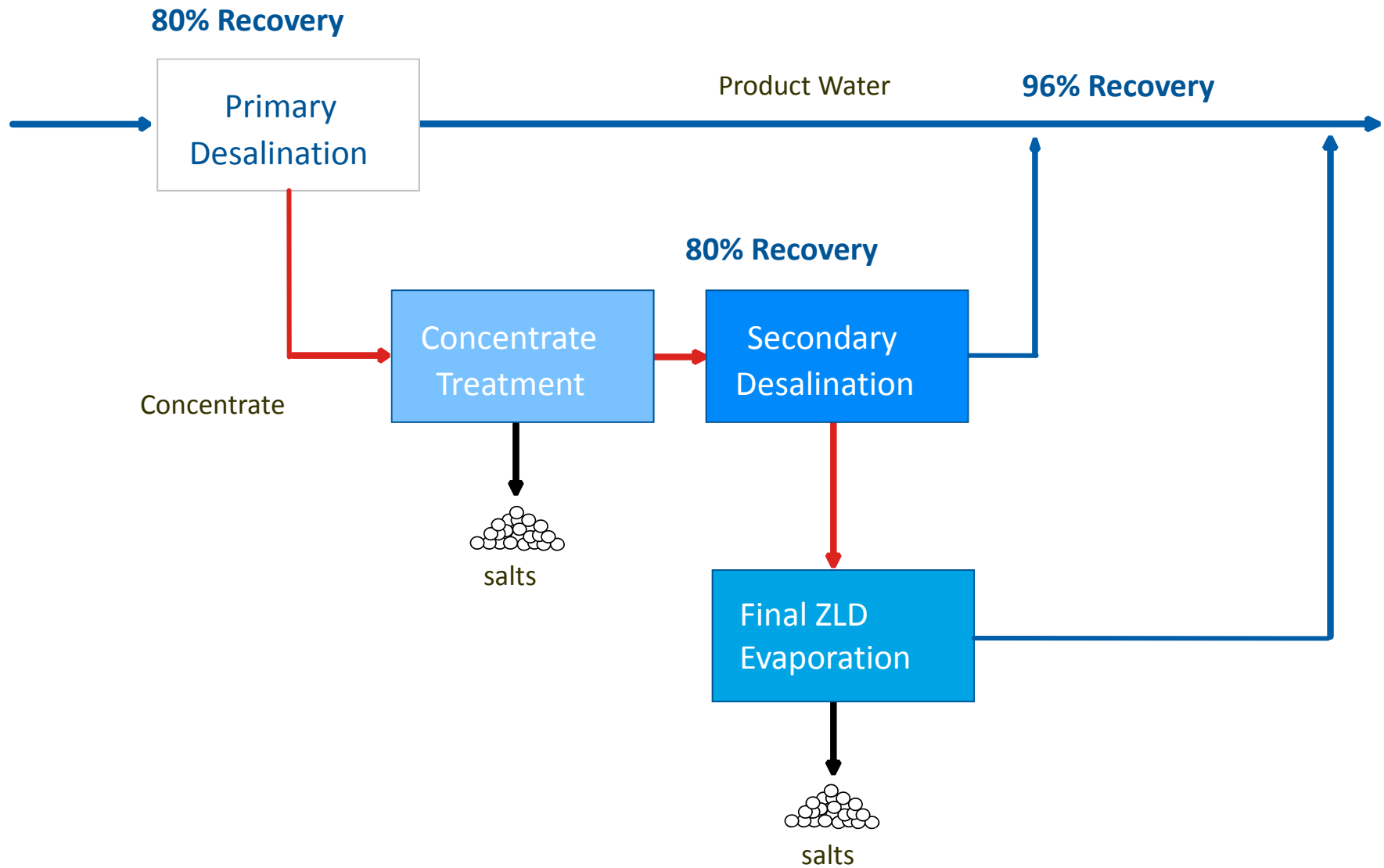

# COSTS AND ENERGY INCREASE THROUGH THE PROCESS

Example – Brackish water

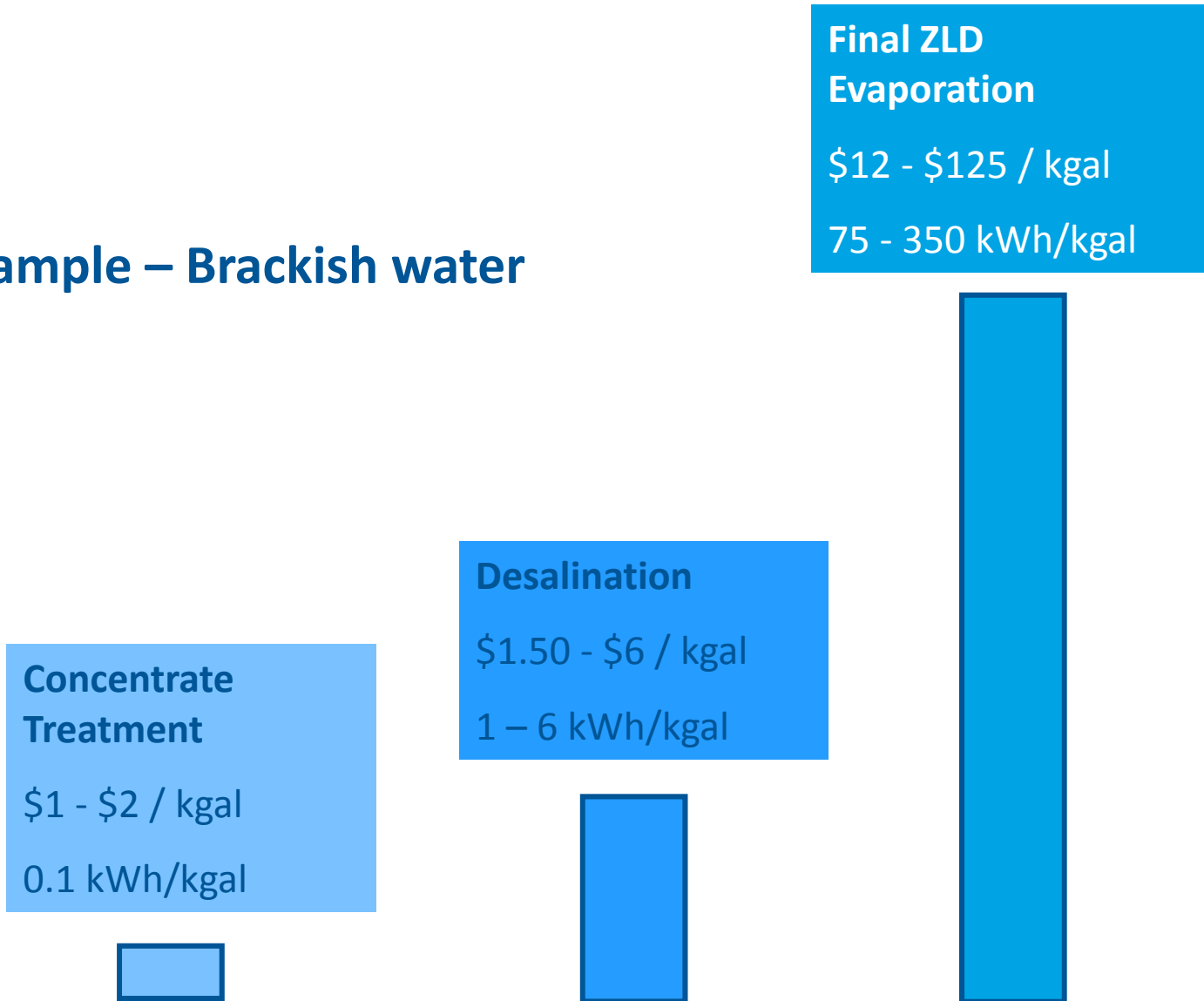

# ASSET MANAGEMENT

## Smoothing the flow

3,000 kilometres of mains = 38% of Hong Kong's total water distribution network = HK\$21.81b investment

Trend of main bursts against progress of mains replacement and rehabilitation programme

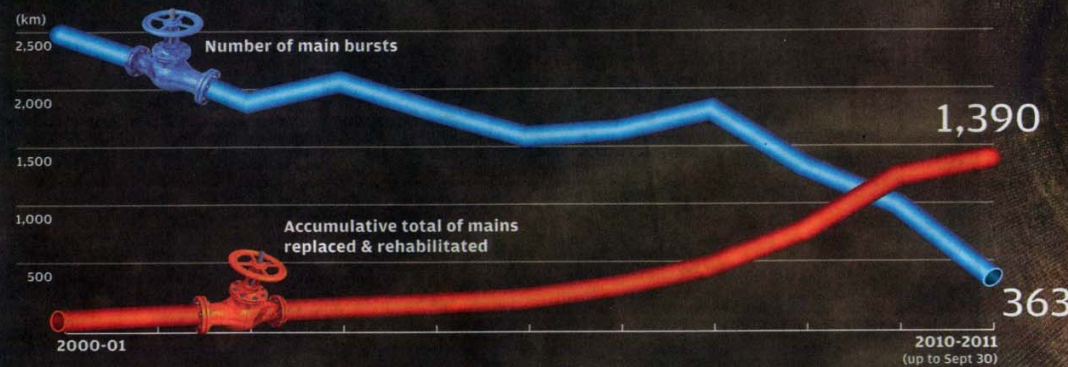

A worker repairing the interior of a water main running under the Lion Rock Tunnel

## Replacement programme is easing pressure on ageing water supply system Turning the tide against burst pipes

### Christopher Dewolf

A spate of water main bursts this year has left some wondering if Hong Kong is sitting on a ticking time bomb of ageing water pipes. The most recent burst, last week, left thousands in Taikoo Shing and other eastern Hong Kong Island estates without fresh water for 12 hours.

The bursts have been blamed on old water pipes that have reached the end of their service lives, making them vulnerable to leaks.

But a contractor who has replaced many old pipes says there is nothing to worry about because the government is investing HK\$21.81 billion to

replace more than a third of its water mains.

"The Hong Kong government has been approaching the issue systematically since 2000 and is well on the way to rehabilitating and replacing 3,000 kilometres of water mains by 2015," said Alan Man, managing director and vice-president at Black & Veatch, one of several contractors working for the government's water mains replacement and rehabilitation programme.

The 3,000 kilometres of mains that will be replaced make up 38 per cent of the city's total water distribution network. 1,390 kilometres of mains have already been replaced,

with the rest scheduled to be replaced by 2015.

More than a quarter of Hong Kong's water mains are over 30 years old, which is the normal lifespan for many galvanised and cast iron pipes. Since Hong Kong's varied topography can create huge build-ups of pressure inside the pipes, water leakage is a constant problem, which can sometimes lead to burst pipes.

Recently, to fight leakage, the government has been installing pressure-reducing valves inside pipes, which has cut the percentage of water lost to leaks from 25 per cent in 1999 to 20 per cent today. The number of water main bursts has de-

**You do not have the luxury of opening up the road and laying a new pipe to replace the old**

Alan Man, managing director and vice-president, Black & Veatch

creased even more substantially, from 2,479 in the 2000/01 financial year to 988 in 2009/10, according to the Water Supplies Department.

Replacing old pipes has not been easy. "Improving the buried infrastructure in a dense environment like Hong Kong is sometimes like threading the eye of a needle," said Man. "You do not have the luxury of simply opening up the road and laying a new pipe to replace the old."

As a result, new technologies have been developed to replace water mains without digging into the ground. In one case, workers actually entered the water main that runs underneath the Lion Rock Tunnel to

reinforce its walls by hand. They used a fibreglass fabric that is normally used to patch cracks on boat hulls.

Underneath the Tolo Highway, a new polyethylene pipe was inserted into a 3 kilometre stretch of old pipe a technique known as swage lining. It was the first time in the world such a procedure had been completed on such a long water main.

Most of the new water mains being installed are made from polyethylene and ductile iron, which have an expected lifespan of at least 50 years. By the time the replacement programme ends in 2015, nearly two-thirds of Hong Kong's water pipes will be less than 10 years old.

# BENEFITS OF ASSET MANAGEMENT

- Proven to reduce cost of ownership by as much as 30 percent.
- Enhance risk management programs
- Improve levels of service for customers
- Conservation of resources





# THE GEARING OF WATER & ENERGY



- Inextricably linked at every stage of production
- VFDs for water pumps
- Energy recovery devices
- Microturbines
- Cogeneration
- Advanced Decision-making tools

Building a **world** of difference.®

**Together**



**BLACK & VEATCH**

[www.bv.com](http://www.bv.com)

# SHALE GAS – HOW CAN WE BETTER MANAGE THE WATER RESOURCES?

## Current Approach:

- 5 MGallons of Freshwater / well
- 2 MGallons of Flowback/Produced Water Hauled for Disposal
- 1000s of Trucks

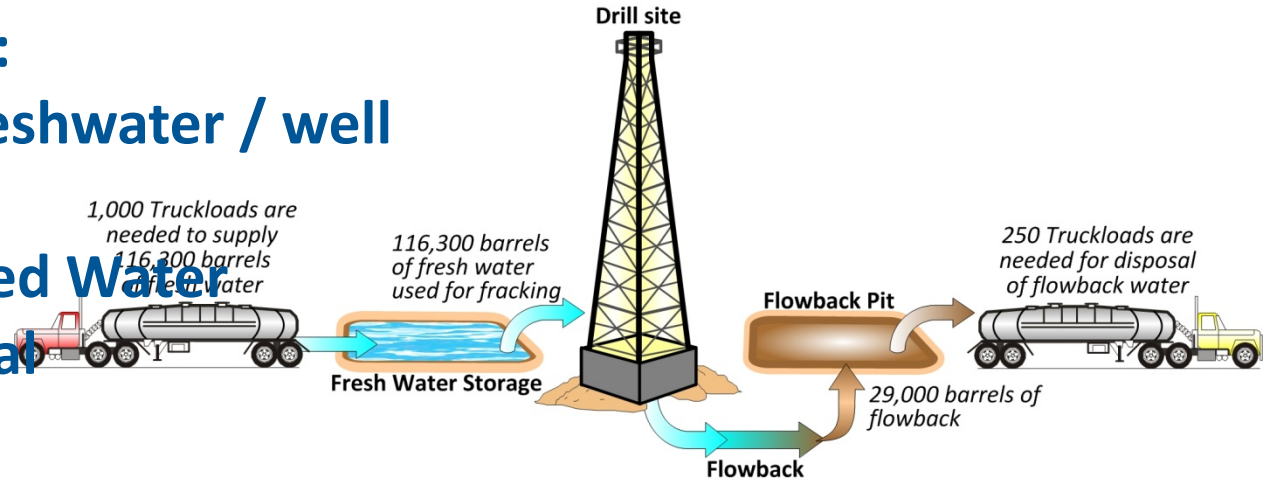

## 100% Recycle Model:

- 3 MGallons of Freshwater / well
- 0.2 MGallons of Flowback/Produced Water Hauled for Disposal
- 100s of Trucks

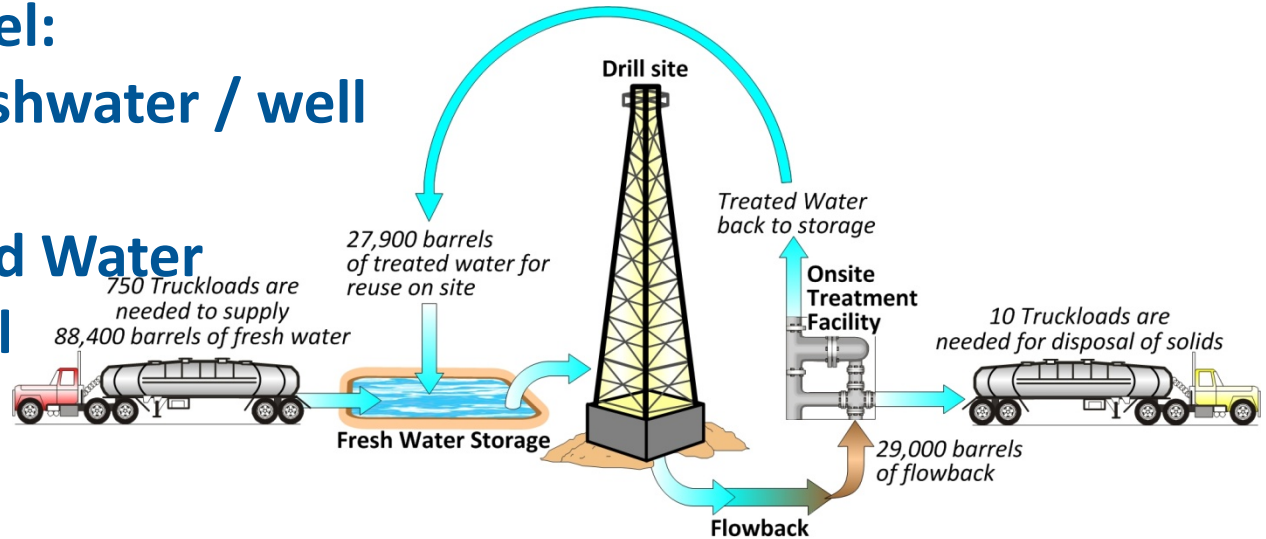

# DEVELOPING SUSTAINABLE ENERGY SOLUTIONS IN THE WATER INDUSTRY

- **Macro-level – Tracking at global level – population growth, Urbanization, build out cities with precious little room for new infrastructure, Cities of the Future, Livable Cities,**
  - small footprint technologies
  - Provide community amenities as well as treatment systems
  - Drive to industrial application scale/commercial building scale/residential scale
- **Direct potable reuse**
- **Membranes that don't foul and have reduced energy requirements**
- **VFD water pumps**
- **Smart grid/smart water/smart gas**
- **Advanced meters**
- **Combined renewables and water treatment systems.**
- **Decision making tools for water resource management** that address energy efficiencies. Most operations are now focused on pushing when needed where needed often just in time.
- Zero-liquid discharge
- Micro turbines to capture hydraulic grade differences
- Energy recovery devices in existing systems – GWRS expansion
- Creating standards for meters
- Making business case for adding sensors, collecting and integrating data, programming systems

## KEY INDUSTRY ISSUES DRIVING NEED FOR SMART ANALYTICS

- Data Overload
- Operational Complexity
- Skilled Workforce Shortage
- Aging Assets
- Tight Operating Margins
- Volatile Markets (Chemicals, Energy, Financial)
- Regulatory Compliance + Future Uncertainty
- Drive for Efficiency



**Analytics can leverage utility-wide data**

# THE BEST ANALYTIC SOLUTIONS WILL COME FROM COLLABORATION

- There is an opportunity to develop analytics that:
  - Improve efficiency – energy, chemicals, etc.
  - Adapt -- to achieve long-term health of system
  - Involve manufacturers and engineers in remotely monitoring and diagnosing issues and performance



# TECHNOLOGIES

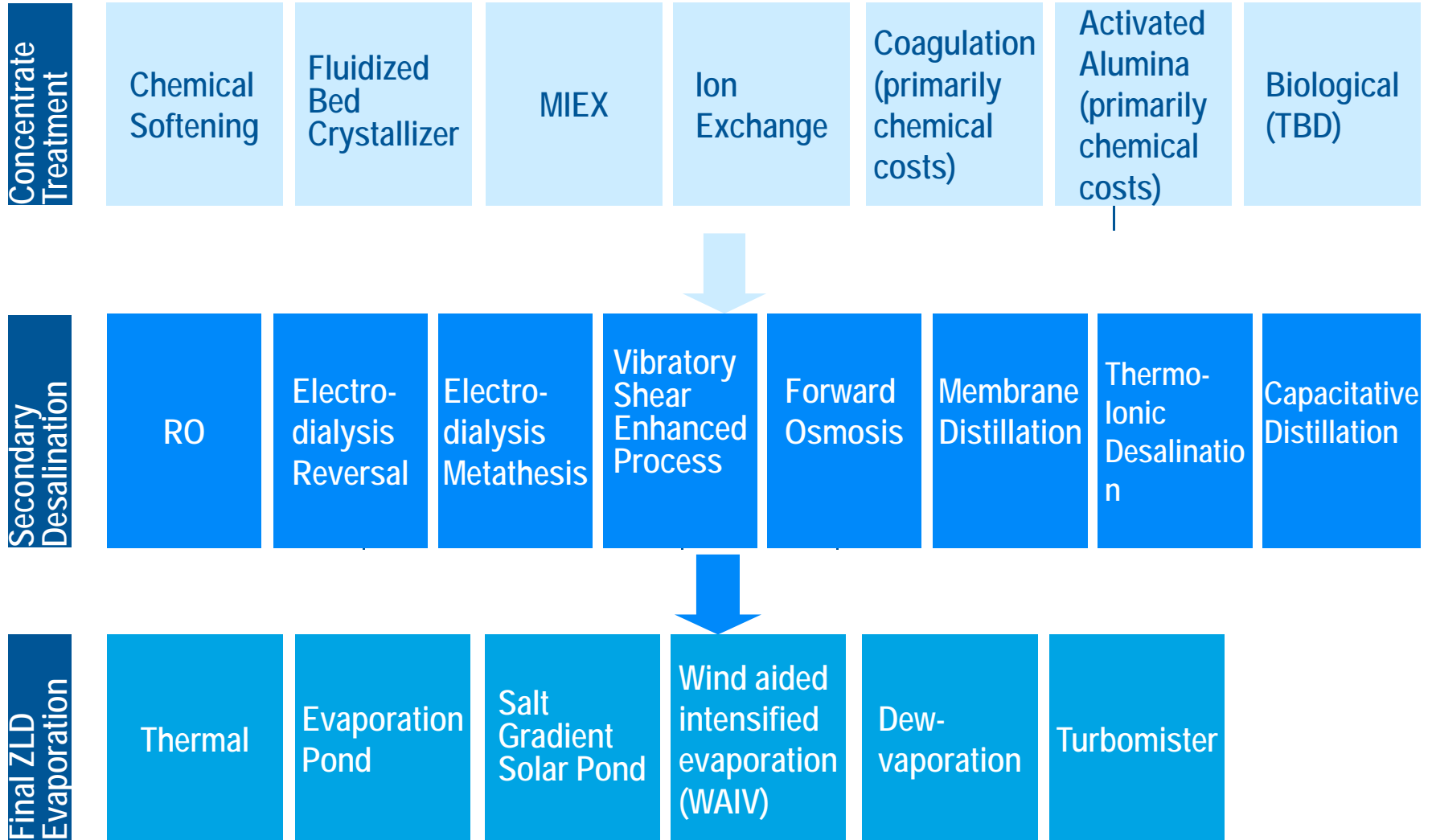

Presented By:  
Lorraine White

# Outreach & Engagement

## The Importance of Communication in Maximizing Water-Energy Research Results

National Science Foundation  
Energy Water Nexus Workshop  
NSF Headquarters, Washington DC  
June 10 & 11, 2013





# Outreach & Engagement:

We we will discuss:

- The difference between the two.
- Its important for Research
- Different approaches
  - Collaboration v.  
Coordination
- Successful Example
  - Water-Energy Research  
Work Group



# Getting Beyond “BAU” ...



- New policy frameworks
  - Systems and Integrated Approaches to Resource Management
- New metrics & tools for efficiency programs
  - Water-Energy-Carbon Calculators that help optimize decisions
- Creating pathways to the Utilities of the Future
  - Distributed resources & infrastructure
- New technologies
  - That save both water and energy
  - Address key environmental constraints
- Cost-effective Retrofits & Upgrades
  - Much of our existing infrastructure is in Crisis



# What Do They Mean?



## OUTREACH

- Many things to many people
  - Exceed
  - Transcend
  - Reach Out
  - Overstep
- “Extending of services or assistance beyond current or usual limits “

## ENGAGE

- Many things to many people
  - Involve
  - Hire
  - Engross
  - Promise
- “To come together and Interlock”



# “Where Discoveries Begin”



- NSF is here to
  - Promote progress of science
  - Advance national health, prosperity and welfare
  - Do basic research (i.e., pure, fundamental) –
    - to expand understanding of fundamental principles
    - conduct research that arises “out of curiosity” as opposed to applied research or practical application of research
  - But to what end? **TO INFORM**
  - **Outreach and Engagement are Critical**





**“Leadership is the art of getting someone else to do something you want done because he wants to do it.”**

**Dwight D. Eisenhower**

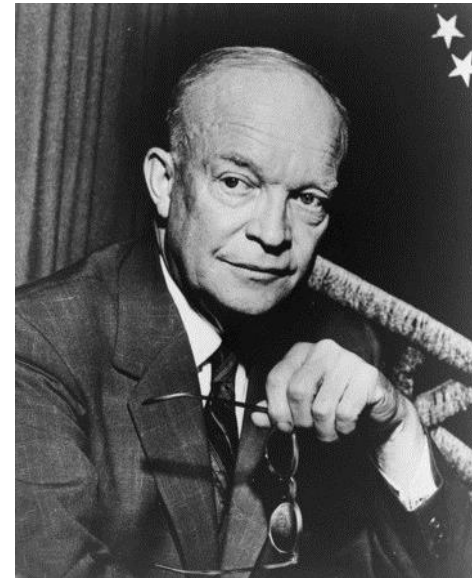



WHAT GOOD IS RESEARCH WITHOUT OUTREACH?

**IF NO ONE KNOWS ABOUT IT?**

**IF NO ONE USES IT?**

# Water-Energy Policies



- **2003 IEPR - Power Generation**
  - Non-fresh Supplies or Alternatives
  - ZLD
- **2005 IEPR – System and End Use Conservation and Efficiency**
  - Saving Water Saves Energy
  - Reduce Peak Demand
  - Renewable and Self-Generation
- **2007 IEPR – Tools and Implementation**
  - EM&V



# Keep Focus on the Goal



- Know the purpose of the research and communicate its value to the benefactors
  - What problem are you trying to solve and how does that fit into the bigger context of economic, environmental, social needs?
- Engage your audience to help them understand the value to them.







HOW CAN WE MAKE THE MOST OF A PROJECT?

# COLLABORATION

# ENGAGE: Early & Often



- **Build & maintain partnerships that can advance your research.**
  - Partner with others to build credibility and expertise.
- **Explain how your research address what your audience values and what the research brings to them clearly?**
- **Have a dialogue- a two way communication.**
  - Your audience may hold the key to your breakthrough.
- **Track and Report**



# Collaborative Science



- Collaboration - working together to achieve a common goal,
- Cooperation - helping others to achieve individual goals
- “Collaborative and Team Science: A Field Guide” by Bennett, Gadlin and Levine-Finley, 2010 National Institutes of Health <http://teamscience.nih.gov>
- [http://ccnmtl.columbia.edu/projects/rcr/rcr\\_science/foundation/index.html](http://ccnmtl.columbia.edu/projects/rcr/rcr_science/foundation/index.html)





Example of the Need of Better Communications

# BOTTLED WATER

# Bottled Water – Why do people still buy it?



- US consumers spend more than \$11B a year on bottled water
- More than 17M barrels of oil, not including transportation, is required
- Bottling water produced more than 2.5M tons of carbon dioxide
- 3L of water for 1L of bottled water
- More than a quarter of bottled water is sourced from municipal tap water
- Less than 15% of water bottles are recycled; the rest land in the garbage and is the fastest growing source of municipal waste.

Source: Pacific Institute



Alliance for Water Efficiency & ACEEE's Successful Engagement

# **WATER-ENERGY RESEARCH WORK GROUP**

# Water-Energy Research Work Group

- More than 70 Individuals
- All Sides of the Water-Energy Nexus:
  - Water & power utilities;
  - Public works and county agencies;
  - Universities and academics
  - Private and public research groups;
  - Local, state, federal, and international agencies;
  - Climate and resource advocate groups;
  - Industry and consulting firms.



# W-E Research Roadmap & Work Group



- *Water-Energy Nexus Research:*
  - *Recommendations for Future Opportunities*
- W-E Nexus Research Database
- Active Exchange of Information, Results and Ideas
  - <http://www.allianceforwaterefficiency.org/Water-Energy-Research-Group.aspx>



# W-E Nexus Research Recommendations



1. Develop comprehensive studies and associated guidelines to conduct a detailed audit of embedded energy demands for an entire local, regional or national water/ wastewater system for purposes to determining system optimization.
2. Assess technical and economic energy efficiency and demand response potential in water and wastewater systems and develop industry accepted guidelines for such studies on individual systems.
3. Identify and eliminate regulatory barriers to co-implementation of efficiency programs in the water and energy sectors.
4. Develop water AND energy industry-accepted Evaluation, Measurement and Verification (EM&V) protocols for use in efficiency programs.



# Recommendations (cont.)

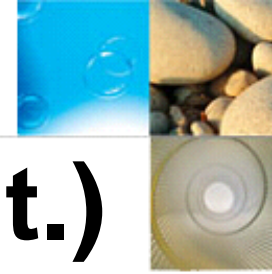

5. Develop industry standards, protocols and successful business models for advanced biogas development programs and net zero facilities at wastewater treatment plants.
6. Conduct landscape irrigation equipment efficiency potential studies that can support establishment of efficiency standards
7. Identify rate structures, price constructs, and financing mechanisms that eliminate the financial disincentives of efficiency programs and alternative supplies use in the water sector.
8. Evaluate technologies and practices that can reduce the energy demand of desalination and lower its costs.
9. Continue investigations into the water energy tradeoffs of differing resource development and management choices that can better inform multi-sectorial integrated resource planning.



# Recommendations (cont.)



10. Develop technologies and protocols that can increase water use efficiency and re-use, support water supply switching, and reduce water quality impacts of power generation facilities and other energy fuels development.

11. Assess potential impacts to water supplies and quality of energy resource development, such as fracturing for natural gas and biofuels development; identify methods, practices and technologies that reduce or eliminate these impacts.

12. Supply chain and product embedded water-energy evaluations that can inform consumers of the energy and water intensity of the products or services they buy.

13. Identify effective methods, forums, practices and other mechanisms for communication and engagement by the research and policy communities with practitioners and adopters to ensure commercialization and adoption of preferred research results and technological developments that maximize acceptance and application in the marketplace and public service industry.





How to do it all...

# DIVERSIFY PARTNERSHIPS

# Engage Beyond Your Peers



- Engage with
  - Industry
  - Users/Practitioners
  - Planners
  - Regulators
  - Policy and Program Decision-makers
  - Financiers & Venture Capitalists
  - Consultants
  - Social Scientists
- Use Effective Engagement & Communication Tools
- Develop Advocates
- Create Buzz



# A Role for Everyone...



Barriers	Challenges	Opportunities	Key Stakeholders
<b>Institutional</b>	<ul style="list-style-type: none"> <li>•Single resource &amp; entity perspective; decades of thinking to be un-done:</li> <li>•Jurisdictional &amp; regulatory “buckets” inhibit cross-cutting programs</li> </ul>	<p>New policies, programs &amp; practices that enable cross-cutting programs and measures; e.g.:</p> <ul style="list-style-type: none"> <li>•Optimize water &amp; energy efficiency together</li> <li>•Strive for sustainable water &amp; energy resources with zero net energy and carbon</li> <li>•Allow cross-subsidization where beneficial to achieve incremental benefits</li> <li>•Provide regulatory pathways to the utilities of the future</li> </ul>	<ul style="list-style-type: none"> <li>•Policymakers, regulators, legislators</li> <li>•Water &amp; wastewater agencies</li> <li>•Energy Utilities</li> <li>•Water &amp; energy customers</li> <li>•Environmental &amp; sustainability advocates</li> </ul> <p><i>[Note: challenges &amp; opportunities different for IOUs vs. POU's]</i></p>
<b>Data, Tools &amp; Methods</b>	<ul style="list-style-type: none"> <li>•Insufficient data of the types &amp; forms needed to effectively evaluate tradeoffs</li> <li>•Tools &amp; methods not sufficient</li> </ul>	<p>Data &amp; analytical methods, models &amp; tools that enable optimizing multiple resource, economic and environmental goals on a fully integrated basis</p>	<ul style="list-style-type: none"> <li>•Regulators</li> <li>•Water &amp; energy sectors</li> <li>•Academia</li> <li>•Researchers</li> <li>•Developers of data systems &amp; solutions (SCADA &amp; other)</li> </ul>
<b>Economic</b>	<ul style="list-style-type: none"> <li>•Significant disparity between prices of water vs. energy</li> <li>•Regional &amp; agency specific tradeoffs vary significantly</li> </ul>	<ul style="list-style-type: none"> <li>•Elevate public purpose goals (e.g., evaluate “marginal supplies” on a more macro basis)</li> <li>•Decouple revenues from earnings (much harder for publicly owned utilities)</li> <li>•Special purpose investment funds (e.g., “public benefit”)</li> </ul>	<ul style="list-style-type: none"> <li>•Water &amp; wastewater agencies</li> <li>•Energy utilities</li> <li>•Their regulators &amp; constituents</li> </ul>
<b>Technology</b>	<ul style="list-style-type: none"> <li>•Water &amp; energy need each other, both in production and in use; but technology development efforts often not synchronized</li> </ul>	<ul style="list-style-type: none"> <li>•Prioritize RD&amp;D investments that yield multiple value streams</li> <li>•Multi-sector investments &amp; incentives</li> </ul>	<ul style="list-style-type: none"> <li>•Federal &amp; state agencies and industry associations that establish standards</li> <li>•Technology developers, equipment manufacturers, venture capitalists</li> <li>•Regulators, water agencies, utilities (that incentivize efficiency)</li> </ul>
<b>Information</b>	<ul style="list-style-type: none"> <li>•Awareness is key to change, but building &amp; communication of knowledge has been slow</li> </ul>	<ul style="list-style-type: none"> <li>•More collaboration across multiple sectors</li> <li>•More sharing of information &amp; insights</li> <li>•More education &amp; awareness: policymakers &amp; regulators, market participants, consumers &amp; constituents</li> </ul>	<ul style="list-style-type: none"> <li>•All of the above</li> </ul>

# “Make it so.”

- **ENGAGE** – Early & Often
- Know **WHY** you are doing the research



- Know your **AUDIENCE** & the **END GOAL**.
- Build & maintain **PARTNERSHIPS**.
- Get your audiences' **ATTENTION & KEEP IT**.
- Be **CLEAR, DIRECT & HONEST**.
- Have a **2-WAY DIALOGUE**
- **Track and Report**



# Research Needs



## Investigate

- Methods & practices of communication
- Key strategies to affect behavioral change
- Social constraints to adoption / deployment & how to overcome them
- Market mechanisms that can be leveraged for research support
- New Policy & new programs that can facilitate effective communications

## Break out session

- Discuss what is needed researchers to do effective outreach & engagement
  - How do we enhance O&E?
  - How do we effectively collaborate/coordinate?
  - How do we effectively translate technical issues into plain language?







***“Anyone who can solve the problems of water will be worthy of two Nobel Prizes – one for peace and one for science.”***

***John F. Kennedy***



# To continue the dialogue, contact:



**Lorraine White**  
**Water-Energy Program Manager**  
916.631.4540 cell: 916.990-2410  
lwhite@geiconsultants.com



GEI Consultants, Inc.  
2868 Prospect Park, Ste. 400  
Rancho Cordova, CA 95670  
916.631.4500 fax: 916.631.4501  
[www.geiconsultants.com](http://www.geiconsultants.com)