

Is lack of awareness of the countersteering effect in motorcycles a causal factor in swerve to avoid collisions?

Rod Shephard

A thesis submitted in partial fulfilment of the requirements of Teesside University for the degree of Doctor of Philosophy.

September 2013

Is lack of awareness of the countersteering effect in motorcycles a causal factor in swerve to avoid collisions?

Rod Shephard

This thesis describes research in the field of motorcycle collision investigation, especially fatal collisions where the rider of a two wheeled vehicle cannot explain what occurrence took place. This thesis will investigate whether a lack of understanding of the countersteering phenomenon allows motorcyclists (in emergency situations) to enter the danger area which the rider is attempting to avoid, compared to countersteering where the machine will move away from the danger. For instance, if the rider of a two wheeled vehicle recognises the need to avoid an obstacle he has two choices either to swerve or counter steer in an attempt to avoid it. The effect of either choice on novice and experienced riders alike is investigated.

The research focuses on three main areas. The rider, rider training and how the rider manoeuvres the motorcycle. The physical aspects of riding a motorcycle, especially how the rider steers the motorcycle as it progresses from straight running through a swerve manoeuvre. Finally, how significant is the force that is generated when the rider swerves away from danger.

Salient points

This thesis makes the following contributions.

- Little empirical knowledge was previously available about how riders dealt with these avoidance techniques. This research added to that knowledge by carrying out much larger empirical analysis and extending that existing knowledge.

Declaration

This thesis describes work carried out between 2006 and 2013. No part of this thesis has been submitted for a degree, diploma, or other qualification at any university. Except where explicit reference is made to the work of others, this thesis is the result of my own work. All quotations have been distinguished by quotation marks and the sources of information are specifically acknowledged.

Acknowledgements

I would like to express my sincere appreciation to all of those who made this work possible. First to my Director of study Dr Andy Campbell for his endless patience, superb guidance and constant support at all times, not to mention his electronics skill in building equipment.

I am also indebted to the Datron Technology for their technical support, advice and loan of sensors and also to Vericom Computers Inc. for their technical assistance with the data collection software.

I am most grateful to Sean Hayes of Circuit Based Training for his enthusiasm and to his students without whose co-operation the study would have been much more difficult.

A special thanks to Tim O'Donnell and his colleagues from the Leicestershire Police Collision Investigation Unit who assisted in the final stages of the testing.

I would like to extend my deepest gratitude to my wife Wendy for her unending patience, love and encouragement without whom this work would not have been possible.

Acknowledgement is due to AiTS for partially funding this project.

Finally, my thanks to the Teesside University for providing this opportunity for me.

Abstract

The countersteering effect in motorcycles describes the apparent need to steer in the wrong direction in order to cause the chassis of the vehicle to lean over in the required direction just prior to executing a turn. The inherent danger with this procedure is that in an emergency situation where a motorcyclist must execute a sudden swerve to avoid a collision, the required behaviour is counterintuitive and panic may cause the rider to make the wrong initial movement thereby reducing their chance of avoiding a collision. As the importance of the countersteering effect is not taught in UK motorcycle training courses, the current work has attempted to establish whether doing so could significantly improve the ability of riders in swerve to avoid manoeuvres. An initial survey of motorcycle riders suggested some confusion about the nature of countersteering. To explore this further, four groups of riders with different levels of experience and training: novice, experienced, advanced and expert, were tested over a simple swerve to avoid course that was based on the procedure in the current UK motorcycle test. All the riders used the same motorcycle with on-board instrumentation to record the steering effort and the response of the machine. The tests were also videoed to gain extra information about rider behaviour. The results suggest that those riders that had been trained in exploiting countersteering were better able to avoid the obstacle and significantly better at returning the machine to the desired path thereby avoiding a potential secondary collision. It appeared that those riders who had learned by experience were still not proficient when faced with a sudden swerve to avoid scenario.

Table of Contents

CHAPTER 1	INTRODUCTION	1
CHAPTER 2	LITERATURE REVIEW	6
2.1	ANYONE CAN RIDE A BIKE IN A FEW MINUTES	6
2.2	EXISTING STEERING THEORY AND MODELS	11
2.2.1	<i>The five manoeuvres to evaluate a motorcycle's manoeuvrability.....</i>	<i>11</i>
2.3	BALANCE, STABILITY, CONTROL AND STEERING RESPONSES	12
2.4	MOTORCYCLE-RIDER SERVOMECHANISM STEERING THEORY	16
2.5	HANDLING TEST PROCEDURES AND RIDER SKILL INFLUENCES	19
2.6	RIDER INPUTS AND POWERED TWO WHEELER RESPONSES FOR PRE-CRASH MANOEUVRES	23
2.7	THE KNOWN COUNTERSTEERING THEORY	25
2.7.1	<i>Countersteering.....</i>	<i>25</i>
2.7.2	<i>Limitation to the theory.....</i>	<i>26</i>
2.8	CONCLUSIONS	28
CHAPTER 3	THE GEOMETRY OF MOTORCYCLES	31
3.1	THE GEOMETRY OF MOTORCYCLES	32
3.1.1	<i>Centre of gravity.....</i>	<i>33</i>
3.1.2	<i>Wheelbase.....</i>	<i>34</i>
3.1.3	<i>Steering head angle</i>	<i>34</i>
3.1.4	<i>Offset.....</i>	<i>35</i>
3.1.5	<i>Trail.....</i>	<i>36</i>
3.1.6	<i>Combining caster angle and offset to produce trail.....</i>	<i>36</i>
3.2	THE RIGHTING MOMENT PRODUCED BY TRAIL	36
3.3	STEERING-HEAD DROP AND CAMBER ANGLE.....	39
3.4	THE STEERING TORQUE	40
3.5	THE GYROSCOPIC EFFECTS	41
3.5.1	<i>The moments generated and their effect on the motorcycle and rider</i>	<i>43</i>
CHAPTER 4	THE QUESTIONNAIRE RESULTS	45
4.1	INVOLVEMENT IN SWERVE TO AVOID INCIDENTS	45
4.2	PASSING THE TEST	49
4.3	COUNTERSTEERING TRAINING	49
4.4	RIDER MISCONCEPTIONS	51
4.5	DISCUSSION	52
CHAPTER 5	EXPERIMENTAL DESIGN	56
5.1	THE TEST MOTORCYCLE	56

5.1.1	<i>Riding Posture</i>	56
5.1.2	<i>Power to weight ratio</i>	58
5.1.3	<i>The chain/gear or belt drive system</i>	58
5.1.4	<i>The shaft drive system</i>	59
5.1.5	<i>Suitability for instrumentation</i>	59
5.2	CONCLUSION	60
5.3	THE INITIAL TEST COURSE	62
5.4	RIDERS	63
5.5	INSTRUMENTATION	64
5.6	OBSERVATIONS	66
5.7	REVIEW OF THE INITIAL INSTRUMENTATION AND TEST MANOEUVRE	66
5.8	THE REVISED TEST COURSE	67
5.9	RIDER SELECTION	69
5.9.1	<i>Anticipation by riders</i>	70
5.10	TIME TAKEN TO CALIBRATE AND SET UP THE DAQ	70
5.11	HOW DOES A RIDER INITIATE THE TURN?	71
5.12	WAS THE INSTRUMENTATION CAPTURING THE CORRECT DATA	71
5.13	INSTRUMENTATION REVIEW	72
5.14	THE REVISED INSTRUMENTATION	73
5.14.1	<i>The steering system</i>	73
5.14.2	<i>The Main Frame and DAQ</i>	77
5.15	DISCUSSION	79
5.16	CONCLUSION	81
CHAPTER 6	RESULTS	83
6.1	INTRODUCTION	83
6.2	GROUP 1 THE NOVICE / DOT RIDERS	89
6.2.1	<i>Torque</i>	90
6.2.2	<i>Steering angle</i>	96
6.2.3	<i>Lean angle</i>	105
6.2.4	<i>Yaw Angle</i>	112
6.2.5	<i>Observations novice rider group</i>	116
6.3	GROUP 2 THE EXPERIENCED RIDERS	118
6.3.1	<i>Torque</i>	119
6.3.2	<i>Steering angle</i>	126
6.3.3	<i>Lean angle</i>	132
6.3.4	<i>Yaw angle</i>	136
6.3.5	<i>Observations experienced rider group</i>	139
6.4	GROUP 3 THE ADVANCED RIDERS	140
6.4.1	<i>Torque</i>	141

6.4.2	<i>Steering angle</i>	145
6.4.3	<i>Lean angle</i>	152
6.4.4	<i>Yaw angle</i>	158
6.4.5	<i>Observations advanced rider group</i>	162
6.5	GROUP 4 THE EXPERT RIDERS	164
6.5.1	<i>Torque</i>	165
6.5.2	<i>Steering angle</i>	169
6.5.3	<i>Lean angle</i>	174
6.5.4	<i>Yaw angle</i>	179
6.5.5	<i>Observation expert rider group</i>	183
6.6	CONCLUSIONS	184
CHAPTER 7 KEY FINDINGS OF THE RESEARCH		193
7.1	LITERATURE REVIEW	193
7.2	QUESTIONNAIRE RESULTS	194
7.3	EXPERIMENTAL DESIGN	195
7.3.1	<i>Rider groups</i>	195
7.4	EXPERIMENTAL WORK	195
7.4.1	<i>Rider conditioning</i>	198
7.5	VIDEO IMAGING	199
7.6	STATISTICAL TESTING OF THE COLLECTED DATA	199
CHAPTER 8 CONCLUSIONS DRAWN FROM THE RESEARCH		201
REFERENCES		203
DATA TABLES		206
APPENDIX 1		223
APPENDIX 2		224
APPENDIX 3		225
APPENDIX 4		227
APPENDIX 5		230
APPENDIX 6		231
APPENDIX 7		234
APPENDIX 8		235
APPENDIX 9		237
APPENDIX 10		240

APPENDIX 11 241
APPENDIX 12 246
APPENDIX 13 248
APPENDIX 14 253
APPENDIX 15 255

List of Figures

Figure 1 Footprint and Center of Gravity (Spiegel, 1998).....	9
Figure 2 20 degree lean angle (Spiegel, 2010)	10
Figure 3 Steering moment (Cocco, 2005)	26
Figure 4 Rolling moment (Cocco, 2005).....	27
Figure 5 Yawing moment (Cocco, 2005).....	27
Figure 6 Offset and Trail.....	35
Figure 7 Righting moment produced by trail.....	37
Figure 8 Negative, neutral and positive trail	38
Figure 9 Steering head drop.....	40
Figure 10 Gyroscopic precession	42
Figure 11 Discipline of riders in questionnaire.....	47
Figure 12 Untrained Riders - Number of Swerves / Avoids.....	48
Figure 13 Trained Riders - Number of Swerves / Avoids	49
Figure 14 Qualification test prior to countersteering training	50
Figure 15 Riding positions for the cruiser, standard and sports motorcycles	57
Figure 16 Kawasaki GT550 motorcycle.....	61
Figure 17 The original serpentine test course	62
Figure 18 The modified DOT test course	68
Figure 19 Steering torque transducer.....	75
Figure 20 Steering angle sensor	76
Figure 21 Steering rate sensor mounted above the torque transducer	77
Figure 22 Vericom VC4000DAQ mounted on the rear of the test motorcycle...	78
Figure 23 Mallory Park Circuit	81
Figure 24 Torque input by a novice rider.....	85
Figure 25 Steering input by a novice rider.....	86
Figure 26 Lean angle input by a novice rider	87
Figure 27 Yaw angle input by a novice rider	88
Figure 28 Visual representation novice rider	89
Figure 29 Plan view of the manoeuvre	90
Figure 30 Torque plot of the novice group.....	91
Figure 31 Torque plot for novice riders 2, 5, 7 & 9	93
Figure 32 Novice group torque plot with riders 2 & 5 removed	94
Figure 33 Steering plot of the novice group	97

Figure 34	Steering plot for novice riders 4, 7 & 10	98
Figure 35	Steering plot for novice riders 2, 5, 7 & 10	100
Figure 36	Rider 5 steering input during recovery	105
Figure 37	Lean angle plot of the novice group	107
Figure 38	Lean angle plot of novice riders 1, 3 & 4	108
Figure 39	Immediate lean to the right.....	109
Figure 40	Immediate short period lean to the left.....	109
Figure 41	Immediate long term lean to the left.....	110
Figure 42	Delayed short period lean to the left.....	110
Figure 43	Novice rider passing the avoidance cone.....	111
Figure 44	Yaw angle plot novice riders	113
Figure 45	Yaw angle novice rides 1, 6, 7 & 10.....	114
Figure 46	Yaw angles novice riders 6, 7 & 10.....	115
Figure 47	Yaw angles novice riders 4 & 8.....	115
Figure 48	Visual representation experienced rider.....	118
Figure 49	Torque plot of the experienced group	120
Figure 50	Torque plot for experienced riders 1, 2, 3, 5, 6 & 9	123
Figure 51	Torque experienced riders 4, 7 & 8.....	124
Figure 52	Torque experienced rider 10	124
Figure 53	Recover torque experienced rider 7.....	126
Figure 54	Steering angles experienced riders.....	127
Figure 55	Coincidental peak countersteer and torque.....	129
Figure 56	Lean angles experienced riders	132
Figure 57	Lean angles experienced riders 7 & 10.....	134
Figure 58	Experienced rider passing the avoidance cone.....	135
Figure 59	Yaw angles experienced riders	136
Figure 60	Yaw angles experienced riders 7, 8 & 10.....	137
Figure 61	Yaw angles experienced riders 4 & 6.....	138
Figure 62	Visual representation advanced rider.....	140
Figure 63	Torque input advanced rider group	142
Figure 64	Torque input advanced riders 1, 2, 5 & 7	143
Figure 65	Positive torque during the recovery, advanced rider 2.....	145
Figure 66	Steering inputs advanced group	146
Figure 67	Steering input advanced riders 1, 2, 5 & 7	148
Figure 68	Steering input advanced riders 3, 4 & 8.....	149
Figure 69	Steering input advanced riders	150
Figure 70	The advanced group lean angles.....	152

Figure 71	Advanced riders 5 & 9 lean angles.....	153
Figure 72	Advanced riders 1 & 2 lean angles.....	154
Figure 73	Advanced rider 8 lean angle	154
Figure 74	Advanced riders 3, 4, 6, 7 & 10.....	155
Figure 75	Advanced rider passing the avoidance cone.....	157
Figure 76	Yaw angles advanced riders	159
Figure 77	Yaw angles advanced riders 3, 4, 5 & 6.....	160
Figure 78	Yaw angles advanced riders 8, 9 & 10.....	160
Figure 79	Yaw angles advanced riders 1, 2 & 7.....	161
Figure 80	Visual representation expert rider	164
Figure 81	Torque input expert riders	165
Figure 82	Torque input expert riders 1 & 6.....	166
Figure 83	Torque input expert riders 2, 3, 4 & 5.....	167
Figure 84	Steering angle input expert riders	170
Figure 85	Steering input expert riders 1 & 6.....	171
Figure 86	Steering input expert riders 2 & 5.....	171
Figure 87	Steering input expert riders 3 & 4.....	172
Figure 88	Lean angles expert riders.....	175
Figure 89	Lean angles expert riders 1 & 2	176
Figure 90	lean angle expert rider 3.....	177
Figure 91	Lean angles expert riders 4, 5 & 6	177
Figure 92	Expert rider passing the avoidance cone	178
Figure 93	Yaw angles expert group.....	180
Figure 94	Yaw angles expert riders 4, 5 & 6	181
Figure 95	Yaw angle expert riders 1 & 3	182
Figure 96	Yaw angle expert rider 2	182
Figure 97	The mean input and response of the novice riders	184
Figure 98	The mean input and response for the experienced group of riders.....	186
Figure 99	The mean input and response for the advanced group of riders.....	187
Figure 100	The mean input and response for the expert group of riders	188
Figure 101	Comparisons of mean torque forces	189
Figure 102	Comparisons of mean steering angles.....	190
Figure 103	Comparison of mean lean angles.....	190
Figure 104	Comparison of mean yaw angles.....	191
Figure 105	Mean torque and countersteer angles.....	192
Figure 106	Mean Torque and Countersteer Angles	196
Figure 107	Mean Torque and Swerve angle	197

Figure 108 Mean times between T1-T3 & S1-S3	198
Figure 109 Rider and Motorcycle Angles	199

List of Tables

Table 1 Two-way contingency table	45
Table 2 Understanding of countersteering	51
Table 3 Requirements for test motorcycle.....	60
Table 4 Number of tests conducted in each rider group.....	83
Table 5 Combined steering angle and steering adjustments	104
Table 6 Combined steering angle and adjustment experienced riders	131
Table 7 Torque input novice group.....	207
Table 8 Steering input novice group.....	208
Table 9 Lean angle novice group	209
Table 10 Yaw angle novice group	210
Table 11 Torque input experienced group.....	211
Table 12 Steering input experienced group	212
Table 13 Lean angle experienced group.....	213
Table 14 Yaw angle experienced group.....	214
Table 15 Torque input advanced group.....	215
Table 16 Steering input advanced group	216
Table 17 Lean angle advanced group.....	217
Table 18 Yaw angle advanced group.....	218
Table 19 Torque input expert group	219
Table 20 Steering input expert group	220
Table 21 Lean angles expert group.....	221
Table 22 Yaw angle expert group	222

Chapter 1 Introduction

In recent years there has been a revival of motorcycle interest within the United Kingdom, motorcycle sales have increased with the market trend being towards machines with higher engine capacity. Japanese motorcycle exports in 2004 were 1,415,140 units with 33.3% of these coming to Europe. In 2009 only 543,879 units were exported from Japan but 39% still came into Europe. November 2010 exports saw motorcycle export had risen by 19.5% yet the European share still remained at 33.5 (JAMA, 2010). The motorcycle is generally limited to either commuter or pleasure usage. Compact scooters or trial type machines with smaller engine capacities tend to be the commuters choice whilst the pleasure seeker has the opportunity ride the more powerful sport / race replica type machines. The cost implications for the individual in relation to this somewhat simplistic categorisation has led to the 'born again biker' i.e. those who initially purchased a small commuter machine as a matter of financial constraints in early life and who later in life may have returned to motorcycling because they can afford a powerful race replica for pleasure activities.

Motorcyclists unfortunately do have a poor safety record when comparing their "killed and serious injury" (KSI) figure to those of other road users. The road accident casualty statistics for the period 1992 – 2002 show that motorcyclists account for approximately one in seven road deaths. The overall picture is that although motorcyclists make up less than 1% of vehicle traffic their riders incur 14% of the total deaths and serious injuries on Britain's roads (DETR, 2000).

In road traffic collisions involving two wheeled vehicles, it is extremely difficult to determine the exact dynamics of the vehicle immediately prior to impact. Often

tyre marks, gouges and scratch marks are left on or in the road surface from which the actions of the rider may, under certain circumstances be determined. In the absence of any physical marks being left at the scene, any analysis of the collision becomes speculative. In scenarios where there are only gouges and scratches generated once the motorcycle has fallen over, it may not be possible to determine anything other than an estimation of the speed of the vehicle (Medwel et al., 1997), and its direction immediately before and after the collision. Where riders have lost control in a bend or swerve manoeuvre, two distinct mechanisms exist for “falling off”, which can often be deduced from the physical evidence. Both phenomena can occur when the rider is mid-phase in a corner, leaning the motorcycle over to the maximum extent allowed by the transverse grip of the tyres. In simple theory (without gyroscopic effects) the centripetal force required to make the vehicle travel in a curved path is provide by the transverse component of the tyre grip. The tyre is probably the motorcycle’s most important component, the longitudinal and lateral forces acting at the tyre / road interface are best described by the “Magic Formula” (Pacejka, 2007) based on empirical data and is outside the parameters of this research.

Centripetal force required

$$F_c = \frac{mv^2}{r}$$

Maximum grip force available

$$F_g = \mu mg$$

For equilibrium we require

$$F_c \leq F_g$$

Where v is the velocity, r is the bend radius of curvature and μ is the coefficient of friction. Any small change of attitude (and hence the radius of curvature) or velocity can increase transverse grip needed for equilibrium and the rear tyre will

start to slide (side slip). If this situation persists the machine will eventually fall onto its side and the rider will fall off on the inside of the bend -'low side'. If, however, the transverse grip is restored, the sudden increase in the lateral forces tends to return the motorcycle to the vertical position and throw the rider upwards to fall off on the outside of the bend (high side).

In fatality situations where there are no marks, any analysis of what the rider may or may not have done pre-impact is pure speculation. It may be possible to determine causation from witness evidence and post impact movement e.g. excess speed, but the actions that the rider may have taken immediately pre-impact may never be known. It is stated in "The Hurt Report" that

"Motorcycle riders in these accidents showed significant collision avoidance problems. Most riders would overbrake and skid the rear wheel, and underbrake the front wheel greatly reducing collision avoidance deceleration. The ability to countersteer and swerve was essentially absent." (Hurt et al., (1981)

The implication of this statement is that it might be advantageous for motorcycle riders to be taught how to countersteer and swerve.

In a report commissioned by the Department of Transport and carried out by Nottingham University examined a sample of 1790 accident cases covering the years 1997 – 2002 inclusive. One of the conclusions from the research states

"Specific behaviours of motorcyclists themselves also need addressing. Rider skills, while seeming proficient in certain areas were also found to be lacking in others. Attention should be paid to the cornering

techniques of riders in particular; the ability of riders to plan ahead; and the importance of riding within an individual's ability.” (Clarke et al., 2004)

The concept that the riders of pedal cycles and motorcycle do not fully understand the handling characteristics of their machines is not a new one,

“Many cyclists and motorcyclists appear to be ignorant of the limitations of the stability of their machines with consequences fraught with disaster to themselves and danger to other road users.” (Wilson-Jones, 1951)

In principle motorcycles (single track vehicles), are highly manoeuvrable and can be steered and rapidly slowed to avoid obstacles in their paths. It is possible that many riders are not exploiting the handling characteristics of their machines to best effect when cornering or when faced with an emergency situation, such as where it is necessary to “swerve-to-avoid” an obstacle.

Apart from the tragic loss of life, the social / environmental impact and the extremely high financial cost of the investigation, there is clearly an increasing need to examine the dynamics and understand how riders from different training regimes steer the motorcycle. To date little if any on road rider / training comparison has been undertaken in relation to motorcycle steering techniques. The knowledge acquired from such investigations can be used to increase road safety and to develop better rider training techniques.

In this present research, a questionnaire (appendix 4) was initially used to investigate any possible difference between riders who purposefully

countersteer in “swerve to avoid” scenarios compared to those who have not been trained about the need to countersteer in order to swerve-to-avoid. The research has then been expanded to collect empirical data from an instrumented motorcycle to identify differences between the two rider groups. Work is then carried out in explaining the behaviour of riders at various stages within the chosen manoeuvre to show best practice.

Chapter 2 Literature Review

This chapter gives an overview of the results from the literature review. Its purpose is to show how the single-track vehicle is steered, the vehicle characteristics and the interactions between rider and machine.

The scientific study of the motions of single track vehicles has developed over more than 100 years and during that time conflicting conclusions have been drawn. A significant step forward came about due to mathematical modelling. In particular the development of a suitable mathematical model of a motorcycle in free control, and the use of that model to show typical stability characteristics and how those characteristics depend on various parameters (Sharpe, 1971).

2.1 Anyone can Ride a Bike in a Few Minutes

(McKibben, 1978) A paper presented to the Society of Automotive Engineers, raised a number of points which are pertinent to this research.

“Limited testing has been dramatic in showing the vast differences between skilled and unskilled motorcycle riders compared to skilled and unskilled car drivers (McKibben, 1978).

He points out that almost anyone can get into a car and bring the vehicle to a stop in a short distance by harsh application of the foot brake, however to do the same operation on a motorcycle requires skill. To corner at high speed and even possibly exceed the limit of the tyres adhesion in a car demands little more than good hearing to determine when the tyres are at the point of losing their grip and hence the vehicle's directional control is lost. For a motorcyclist to corner at speed, at the limit of adhesion requires considerable skill because even slightly

exceeding that limit can result in the bike being 'yanked' out from under the rider in the briefest of moments.

McKibben (1978) believed that there were two distinct groups within the motorcycle dynamics field, he wrote;

"The first is the experienced motorcyclist, often a self-proclaimed expert on dynamics as well as other areas of motorcycle technology, generally lacking in technical training, invariably a broadcaster of inflexible opinions largely predicated upon hear-say from other equally technically unsophisticated persons. Then in the other camp, we find engineers and scientists heavily involved with computer modelling, highly trained and skilled in theoretical stability analysis but totally without any practical knowledge of motorcycle performance."

It has been suggested that too much has been said in the advertising media to imply that it only takes a few minutes to locate the controls of a motorcycle and the motorcyclist will be capable of dealing with all traffic scenarios. Conversely there is little emphasis placed on the difficulties of operating motorcycles over their performance range

"Recent research may yield some information about the quantitative differences between skilled and unskilled, or inexperienced, motorcycle operators. Until these data are reduced, riders may continue to tour along on their bikes, blissfully unaware of their limitations compared to their abilities to extract nearly optimum performance from automobiles. Motorcyclists are unlikely to confess such limitations, or even to recognise them. So it is incumbent upon scientists to quantify, through analysis and testing, the range of performance capabilities for various classes of motorcyclists." (McKibben, 1978).

McKibben (1978) considers what he determines to be multi-purpose motorcycle design, and concludes that all motorcycle designs are a compromise. The overall design of one machine may afford excellent handling characteristics on open roads and city streets yet will not be optimised for off road riding. Conversely the machine designed to handle well in the off road environment will result in a machine with less than desirable qualities for road riding. Any attempts to seek perfection with this type of machine either on or off road are likely to result in problems for the rider.

Man as a 'master of adaptation' as described by Spiegel (2010) discusses the differences between 'born' specialists and 'learned' specialists. *"The born specialist is one-dimensional and unchangeable but he does not have to learn any-thing, at least not from the ground up. Depending on the level of organisation of the species, the individual might, at most, have to practice the skill a little (as, for example, when a fledgling takes his first few flights). More precisely, pre-existing or easily completed shorter procedures must be pulled together into functional units, which are complete programs that then have to be fine-tuned and polished. This also applies to certain activities among humans, such as when a toddler begins to walk.*

The learned specialist, by contrast, can do almost nothing at first, but proves himself to be remarkably capable of adopting this program or that one or both, and several others, and new ones, like bike riding or swimming. The more routinely he practices an activity, the more the proficiency of its execution will increase and the more like an inborn program it will become. However, a learned program never achieves the rigidity and inescapability of an inborn program. Instead, the person who has adopted a learned program can change it

and develop it further (although not always easily), or adapt it so that it fits a new situation better. It can also be shaped according to one's 'personal style'."

Chimpanzees and certain bears are occasionally 'bipeds' and these animals with professional training can be taught to ride pedal cycles, but they never progress beyond a rudimentary level. Their skills are not much better with other tricks that require balance. Man however is far superior in this respect, because, even standing around man continually makes postural adjustments to maintain his balance. From this ability to balance, which makes use of many different activities it is clear to see that having a rather extreme length-to-width ration which does not occur in other creatures, is a benefit. When comparing man to our closest relatives in the animal world, he has an unbelievably slender, narrow, and tall physical build with an extremely high centre of gravity.

Figure 1 Footprint and Center of Gravity (Spiegel, 1998)

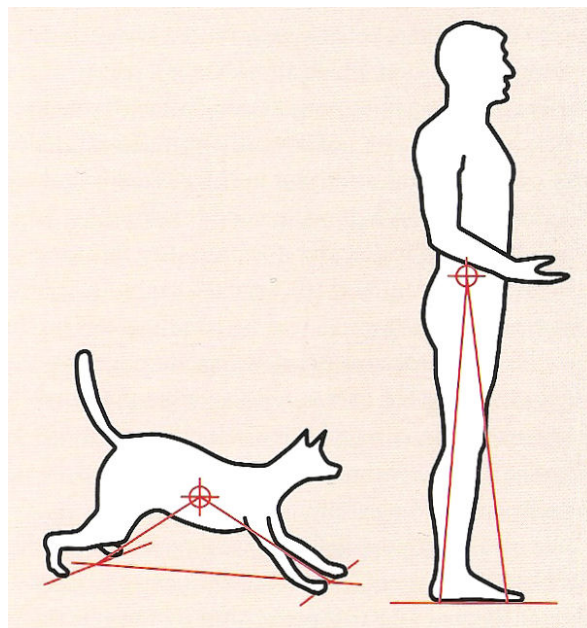

"The four legged beast has a large footprint and a low center of gravity, while the human has a very small footprint and a very high center of gravity" (Spiegel, 1988)

Spiegel (2010) considers that man as a fast runner is already able to handle angles up to about 20 degrees and that it is exactly the same lean angle that arises where natural conditions exist with respect to stiction.

“As soon as a person has more or less learned to ride a two-wheeler, he will immediately make use of the ‘naturally’ available 20 degrees of lean angle, but he will not go beyond those 20 degrees” (Spiegel (2010)).

This has applied for millions of years to all fast runners. In order to lean at greater angles it is not just a case that particular technical conditions exist, there is a requirement for a longer period of continuous practice.

Figure 2 20 degree lean angle (Spiegel, 2010)

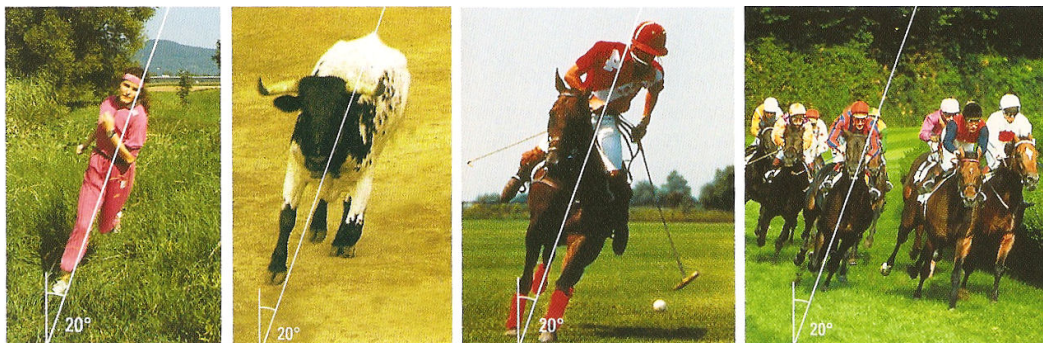

We know that in order to ride a pedal cycle or motorcycle requires complicated steering to maintain balance, to initiate a curved path, to get through the curve and to end the curve at a particular point. Every child who has learned to ride a cycle receives feedback from the vehicle after minimal and coincidental steering inputs (some more helpful than others). It is not a case of ‘when A or B happens, then I have to do C or D’, through evolution man is capable of incorporating the complicated relationship between input and response into a new action program.

2.2 Existing Steering Theory and Models

2.2.1 The five manoeuvres to evaluate a motorcycle's manoeuvrability

In order to test the handling characteristics of a motorcycle it is necessary to consider the interactions of the rider and machine. Whilst negotiating a slalom course the rider will use steering and throttle commands that are totally different to those used during a cornering or lane change manoeuvre. As the motorcycle is considered to be a system with control inputs, its behaviour must be a function of those inputs. Five basic tests are considered when examining the handling characteristics of motorcycles:

2.2.1.1 Steady State Turning

This has proved to be effective in assessing machine manoeuvrability and steering behaviour can be investigated. From the point of view of the novice rider this exercise challenges the ability to balance the lean angle (or roll) and the steering torque.

2.2.1.2 'U' Turn

The physical properties of a motorcycle such as weight, size, the height of the centre of mass, frame design, wheel diameter and inertia all affect the machine's handling dynamics. Hence, negotiating a 'U' turn is much easier for a rider on a scooter than it is on a touring bike.

2.2.1.3 Slalom

During slalom manoeuvres the roll and steering torque change significantly with the speed at which the slalom course is negotiated. Cossalter (2006) determines that at:-

- a) a low velocity of 4.8ms^{-1} the torque peak is reached after the peak roll,
- b) an intermediate velocity of 7.2ms^{-1} they are reached at the same time
and
- c) a high velocity of 15.2ms^{-1} peak torque is reached before peak roll.

The novice rider or even the experienced rider, new to a slalom course, finds it difficult to negotiate until such time as they have experimented with various speeds to find that most suitable for their riding style and the motorcycle.

2.2.1.4 Lane Change

Lane change manoeuvres are dependent on the rider's skill and style and the design of the motorcycle being ridden. The rider must initially move the bike in one direction and then in the other. In practice the rider imparts steering control i.e. steering torque and roll. Dependent on the type of machine being ridden and the speed at which the lane change is executed this will determine the magnitude of effort the rider must exert in order to counter the steering torque and complete the manoeuvre. The longitudinal and lateral distances available together with the skill of the rider will determine the speed at which a lane change can be completed.

2.2.1.5 Obstacle Avoidance

The obstacle avoidance manoeuvre is one where high roll and yaw speeds are developed. The gyroscopic forces generated at the front wheel under these circumstances are fundamental in determining the steering torque that has to be applied to the handlebars by the rider. Consequently the skill of the rider in executing such a manoeuvre at high speed is critical. Lack of skill and the knowledge about why it is more difficult to execute steering manoeuvres at speed amongst some riders may be factors in 'swerve-to-avoid' scenarios.

2.3 Balance, Stability, Control and Steering Responses

The development of the 'perfect handling' motorcycle has taken a giant step forward due to the availability of multibody dynamics analysis software systems. These systems allow the designer/researcher the flexibility to change designs and readily see what is important to the stability and control properties of the machine. The rider of a motorcycle must be considered to be part of the model and has important interactions with the machine. Not only are there the obvious

contributions to the guidance of the machine such as the degree of steer, steering torque and body lean there are also the less obvious ones relating to the structural properties and stabilisation. Clearly the rider's control contribution is dependent on the uncontrolled rider and machine system. *"The rider's control task can be considered to involve fixed or free control. The rider will make a choice depending on the relative difficulties of the two control modes"* (Sharp, 2001).

A fixed control is considered to be one where the steering system is fixed in the straight ahead position and in which the motorcycle and rider are unstable in roll at all speeds. In free control, the steering system is free to steer itself. (Sharp, 2001) sets out that for the self-steering to work well there must be structural integrity and stability within the head stock and that the bearings must be very free with no clearance. Of the many influences on the self-steering system the most obvious are the steering moments arising from the front tyre, overturning moment and side force, gravitational forces on the steering frame, the front tyre load and gyroscopic forces arising from the front wheel and inertial effects. The influences depend a lot on design but are all speed dependent e.g. gyroscopic forces grow in proportion to the speed.

Similarly in free control cornering when any small perturbation from steady turn is made, the change in the state of equilibrium has a powerful effect on any oscillatory modes present. The two most obvious i.e. the most commonly written about by some experts as suggested by McKibben (1978) is 'wobble' and 'weave'. Importantly for the researcher/modeller there are other modes to be considered: capsize, cornering weave (involving a combination of pitch, bounce and rider motion), wobble with some suspension motions and patter (involving front wheel hop and frame twist and steering). As the lean angle increases at

slow speeds the rider will be concerned with maintaining stability, however, as speed increases the burden on the rider to stabilise and guide the machine is very little. Wobble is an unpleasant oscillation of the handlebars which can occur when certain speeds are reached or passing over irregularities in the road surface. (Cocco, 2005) describes the steering suddenly coming alive and starting to oscillate violently for a few seconds, while the motorcycle continues on its path and the rider is unable to intervene in any way at all. He suggests that a wobble is more likely to occur at speeds over 60 to 70 km/h. Weave is a more complex vibration involving oscillation in the roll axis and also in the yaw axis. It is generally an oscillation of the whole machine but mainly the rear end. At high road speed Cocco (2005) suggests that the weave frequency can be such that the rider cannot intervene effectively and the machine cannot be controlled.

Sharp (2001) suggests that normally a turn is initiated by a deliberate, rider applied, steer torque. Turning to the right will require a deliberate steer response to the left thus providing a corresponding steer torque to the left. This initial steer causes the front tyre to camber and sideslip, generating a force at ground level on the left of the motorcycle. This ground level force causes a roll moment about the centre of mass and the roll response necessary for the right turn without loss of balance. The rider then provides the control as the roll develops and then stabilising control once the desired lean angle is achieved. In order to steer out of the turn and return to straight line motion the sequence of inputs required to enter the turn need to be reversed. Steer angle are small unless the speed is very low and the steer torque may be positive or negative, also being very small. However, for rapid but realistic manoeuvres such steering torque is typically very much greater than those required for steady turning. Due to the requirement to

countersteer in order to initiate a turn the transient response of a single track vehicle is very slow compared to those of two-track vehicles.

The effect on the steering and balance of the motorcycle as a result of the crankshaft moment of inertia were examined by Kimishima et al. (1997). The ratio of roll rate and steering torque was used as an index to cornering performance and it was analysed as the influence of the moment of inertia of a crankshaft on the drive and cornering performance. The motorcycle is described as a two axis free gyro that is supported by contact points on the front and rear tyres and is free to yaw and roll. In this way the rider when attempting to lean the motorcycle generates the moment around the roll axis which is given as a function of the steering torque. This shows that the input torque is divided into the gyroscopic moment around the Z axis and that this moment allows the body to turn in the rolling direction.

The ability to control the speed of the motorcycle by the throttle is enhanced by the adequate moment of inertia of the crankshaft. When this is achieved the throttle can be operated with ease and the rider will be able to control the machine without loss of traction. Numerical simulations together with practical tests were undertaken. For the practical tests a 750cc motorcycle was ridden by an experienced rider who had an understanding of motorcycle dynamics. The machine was modified by replacing the flywheel mass at the end of the crankshaft thus changing the specifications of the moment of inertia. Riding performance is enhanced by reducing the crankshaft moment of inertia which provides greater linear acceleration performance. However this response can become too sensitive resulting in difficulties during cornering. Both the gyroscopic effect of the moment of inertia of the crankshaft and the main shaft influences the cornering performance of motorcycles. Riders can effectively use the driving force and side force when the moment of inertia of the crankshaft is at the optimum value and the traction feeling is enhanced.

The position of the overall centre of gravity can easily be predicted. No matter what the shape or size of the motorcycle and rider the centre of gravity will lie on a line joining the machines centre of gravity to the rider's. Comfort of the rider is important bearing in mind the need for the rider to have the ability to move about. Motorcycle tuning/modification as described by Robinson (1997) discusses the requirements of a 'dirt' bike compared to a roadster or racer. The relationship between seat, handlebar and footrest is a critical one: *"it forms an infinitely variable triangle which has one good set of proportions. The seat is fixed by the centre of gravity requirement. From there, the further the handlebar is stretched out, the further back the footrest needs to be. The reach to the handlebar will depend on the rider's size and on the riding conditions. On a racer he needs to get down as low as possible for speed yet have best visibility and access to controls for cornering. The position of the handlebars then dictates the footrest position, so the rider can take some weight on the footrests, can move about rapidly and has a natural, comfortable angle at the hip and knee."* The best way to determine the right proportions is to sit on a lot of machines and find the one that feels right and does not feel awkward. Rider positions for three types of motorcycle are considered at paragraph 5.1.1, fig 15.

2.4 Motorcycle-rider Servomechanism steering theory

The motorcycle-rider servomechanism steering theory as presented by Ethier, (2000) offers an alternative theory that goes some way towards explaining how the push-pull motion of the hands on the handlebars, typical of the countersteering theory, are generated by the rider as a turn is initiated. Ethier (2000) presents two hypotheses and provides four pieces of evidence to support his theory. At this stage it is only necessary to review the two hypotheses:-

1) *"the rider uses his torso lean angle to control the motorcycle lean angle"*

and

2) *“the arms link the rider’s torso and handlebars in a non-obvious but precise way”*

In essence he examines how the rider’s torso moves in relation to the vertical when a turn is initiated. This initial lean of the torso from the vertical is considered to be the INPUT for the new steering theory whilst the angle the motorcycle achieves from the vertical is the OUTPUT. Importantly the rider is considered not to be controlling the steering through voluntary push-pull action on the handlebars but by the torso lean angle which acts on the handlebars and the front wheel.

The next step is to consider the link provided by the arms between the rider’s torso and the handlebars. When the rider leans to the right the left arm pulls the left bar end to the rear and the right arm pushes the right bar end away. In other words as the torso leans to one side the steering is towards the opposite side and this handlebar orientation is roughly proportional to the rider’s torso lean angle. It is pointed out that this relationship may not be linear and that the arms may flex.

In order for the rider to stop the motorcycle from falling over the rider leans his torso in the opposite direction once the machine has reached the desired roll angle. In order for this mechanism to work there must be an error detector and a feedback loop within the system of this new steering theory. The modified Input/Output error detector is copied at appendix 1. If the rider’s torso is leaned to the right the handlebars will be orientated to the left and due to this orientation centripetal acceleration will cause the motorcycle to lean in the same direction as the rider’s torso. Once the machine reaches the desired roll angle the rider leans his torso to the left and the motorcycle will either return to the vertical or maintain the desired roll dependent on the torso in relation to the vertical. Hence this motorcycle-rider steering system is considered to be a ‘follower

servomechanism' i.e. the motorcycle roll angle follows the rider's torso lean angle.

It is recognised (Ethier, 2000) that as the speed of the motorcycle increases so will the steering precision and hence the steering servomechanism operates faster as speed increases. Additionally it is argued that;

“at speeds above 100kph (62mph) the gyroscopic reactions become more important. The rider can still steer by leaning his torso, but the gyroscopic reactions progressively become large enough to flex the rider's arms.”

It is also proposed that this new steering theory may be used to increase driver precision and safety. The argument put forward is that many riders have learned to countersteer, but when faced with an emergency they may forget to employ this training. Consider a swerve-to-avoid scenario in which a motor car pulls out into the rider's path from the left. The rider needs to steer rapidly to the right in order to avoid a collision. If the rider forgets the countersteering theory and instinctively turns the handlebars to the right this may result in a catastrophic incident. (Ethier, 2000) suggests that riders should *“first learn to ride with arms straight and elbows stiff while leaning to the right or left to steer.”*

It is acknowledged that this position would be uncomfortable but certain drills consisting of *“rigidifying”* the elbows and executing tight slalom manoeuvres would develop the reaction of automatically *“rigidifying”* the elbow in emergency situations. Thus if the rider encountered a similar scenario to the one above he could *“lean his torso rapidly in a direction in a precise avoidance maneuver [sic] if the arms are kept straight and the elbows are kept stiff.”*

2.5 Handling Test Procedures and Rider Skill Influences

Zellner and Weir (1978) reported on the evaluation of a sample group of motorcycles regarding their response over a broad range of operating conditions. The aim was to develop test procedures and to correlate performance with subjective evaluation in an attempt to quantify accident avoidance qualities. This was an interim report and only covered steady state turning and a lane change manoeuvre. A group of five motorcycles were used and ranged from 125cc to 1200cc engine capacity. The motorcycle manufacturers are not named but individual machine size, mass, wheelbase and usage is given. Several riders were used in the tests but most of the tests were with an expert test rider, thus allowing *“the study to emphasize vehicle properties and their variation, in the presence of near-optimum rider behaviour, thereby reducing extraneous sources of data variability.”*(Zellner and Weir, 1978).

A light weight instrumentation system was installed in place of the fuel tank on each of the test machines. The system recorded, steer torque, steer angle, roll angle, yaw velocity, lateral acceleration and forward velocity. The rider's lean and pitch angle were obtained by a 2-axis telescoping link attached to the rider's back. The rider's lateral position was recorded by a means of a movie camera. The test site was level and had good frictional properties.

The system was designed to measure the corresponding vehicle control gains ratios of output motion to rider control inputs whilst developing a steady-state turn. Several forms of control were considered. A common approach had been to define the path by using cones, this was ultimately refined by painting a fixed circular arc which the rider was required to follow as closely as possible. Several advantages were noted; these included improved measures of path and

a reduction in the rider tracking biases dependent on the machine size. Other rider controls were attempted with the rider attempting to maintain constant steer torque or roll angle from meters mounted in front of the rider.

The single lane change manoeuvre had been found most useful in assessing automobile handling and therefore a similar manoeuvre was used to examine the motorcycles transient response and performance. Again problems were encountered with vehicle size and the lane being delineated by cones because the rider will consider the course taken through the cones and may not be the same at every run. Various pathways were considered but from a practical point the 'pathline' type manoeuvre has the advantage that it can be used for machines of varying size and no cones are required, the lateral position error can be easily observed and used as a performance measure.

Although no specific conclusions are reached (Zellner and Weir, 1978) the instrumentation did provide the results expected. For the mid ranged motorcycle in a steady-state turn, on a 200ft (60.96m) radius at 40mph (17.88ms^{-1}) the steer torque and steer angle were small in magnitude. It was noted that this would be a closed loop system with the rider continuing to make small adjustments also that there was negligible rider body lean relative to the machine. The same machine on the 80ft (24.38m) lane change at 40mph (17.88ms^{-1}) the rider input signals were generally larger in amplitude and of better quality due to the rapid discrete nature of the manoeuvre. Again for the expert riders there was little rider lean relative to the machine. When considering the three vehicles used in this test i.e. the light and medium weight street machines and the dual purpose street / trail machine there were no significant differences in performance between left and right turns.

Rice (1979) also presented some representative measurements of rider inputs and motorcycle motion responses in relation to similar manoeuvres to Zellner and Weir (1978) in order to show how the available control variables of steer torque and rider lean are utilized. In contrast to the earlier work, Rice (1979) only used one motorcycle namely a 1974 Honda CB360G, and a group of four riders from novice to expert. Instrumentation was comparable with the exception that only the riders lean was measured. The investigation only used a 300ft radius curve for the steady-state turn whereas Zeller and Weir had used a range of 25ft to 700ft depending on the type machine being tested. The main difference was in the approach of Rice, to the lane change manoeuvre. This manoeuvre was carried out at near limit conditions and called into play all the skills of the rider. The test course allowed the rider the ability to consider the course via the 3ft cone delineated approach, the manoeuvre had to be executed within 60ft and the exit was via a 6ft cone delineated path with a lateral displacement of 12 feet measured centrally to the approach and exit paths, see appendix 2. This Rice (1979) considered this to be a true handling test which produced a reasonably challenging situation at moderate speeds.

Rice (1979) identified that the experienced rider controlled the motorcycle quite differently compared to the two more experienced riders. The rider with several years' experience effectively exchanges steer torque for lean control during the initiation of the manoeuvre being undertaken. Examination of the lateral acceleration showed that the turning manoeuvre was not fully coordinated. In a fully coordinated manoeuvre the lateral acceleration would be zero, however in the case of this experienced rider there was a substantial peak during the cornering phase.

Additionally Rice (1979) evaluated a simple turning manoeuvre to illustrate the riding tactic of 'out-tracking'. He provides side by side comparison of the control and response characteristics of a test rider and a simulation. Both steer angle traces identified initial 'off-tracking' with the largest differences being in the applied steering torque. In order to accomplish the manoeuvre the rider employed considerable lean in the opposite direction to the desired turn. In order to produce the 'off-tracking' in the simulator it was necessary to initially apply negative steering torque which was absent in the riders data.

The complex man-machine system by which the rider influences the vehicle dynamics of a motorcycle by the steering manoeuvres is based on somatosensory and visual information gained from the continual evaluation of the surrounding conditions. These dynamics can be generally divided into those appertaining to capability under normal running conditions and those appertaining to those during collision avoidance and it is the influence of a particular rider that can cause the capabilities of a particular machine to vary.

Aoki (1980) carried out an experimental study on motorcycle steering using four large Japanese motorcycles from 650cc to 900cc. This was to determine vehicle dynamics when the rider-machine system is treated as an open loop. The experiments considered were broadly divided into straight-running and curve-running conditions and five varieties of experimental method were attempted.

The five experiments were

- Pulse response by applying steering torque
- High-speed random response where a minor external disturbance was applied to the rider-motorcycle system
- Lane-change response

- Slalom response
- Ramp step response which consisted of a change from straight running to a circular turning over a fixed course.

The instrumentation consisted of a strain gauge sensor to measure the steer torque, potentiometers for the steering angle and the rider lean angle, rate gyros for the yaw and roll velocities an accelerometer for the lateral acceleration and an electromagnetic pickup for the vehicular speed. There is no mention within this work regarding the rider/riders employed and their training or experience. Although it is stated that five runs were made for each individual test it is not clear whether this was a single rider or not.

During the experiments consideration was given to the steer torque and rider lean angle as independent control inputs. Aoki concluded that when the motorcycle is large, rider lean angle as a control input has a very small effect and that the system can be considered subject only to steering torque inputs.

2.6 Rider inputs and Powered Two Wheeler Responses for Pre-Crash Manoeuvres

It is accepted that the ability of the motorcycle rider is a major factor in determining how a modern well-designed motorcycle will respond in various situations. Varat et al. (2004) carried out 53 tests in order to study the response of 'typical riders' performing a lane change manoeuvre on a straight section or public road. The research data was published with the intention that it will assist in the investigation and reconstruction of motorcycle crashes and also assist in providing guidelines for rider education and accident avoidance training.

The test site was a public road which was straight with 3.7 metre wide lanes, the motorcycles used were a 1987 BMW R80 touring machine, a 2002 Honda XR650R off-road bike and a 2003 Honda CBR 600 RR sports. Although the two

Hondas are similar in age, it is noted that the BMW is significantly older. Additionally the BMW has a twin cylinder horizontally opposed engine with the crank shaft running longitudinally to the motorcycle frame, whilst the two Hondas have transverse engines (the CBR has a four cylinder engine whilst the XR650 has only a single cylinder power unit).

Two riders were used in the tests, the BMW R80 and the Honda CBR 600 RR were ridden by a rider whose experience was mostly of riding on normal roads and with little off-road experience, whilst the Honda XR650R was ridden by a rider with extensive 'dirt bike' and limited road riding experience. It is reported that both riders held road licenses and that they had "*participated in additional rider training courses*".

Single and double lane changes manoeuvres were observed but only one test for each motorcycle executing a normal lane changes is analysed and presented (Varat et al., 2004).

The bikes were fitted with an optical speed sensor, tri-axial accelerometer, a steering torque cell together with roll rate and steering angle sensors. The sensor data was captured at 100Hz and all the tests were video taped using a Mini-DV camera watching the motorcycle's approach.

The data is presented in the analysis and it is interesting to note in all three graphs (see Appendix 3) that the peak lean angle of the motorcycle, calculated from the output of the roll angular rate sensor, occurred shortly after the countersteer torque was complete. However, when considering the interrelationship of the countersteer torque and the duration of the steer angle there were similarities between the off-road and sports bike, but in the test

involving BMW R80 the countersteer torque is “*significantly longer in duration than the steer angle*”.

2.7 The known countersteering theory

2.7.1 Countersteering

“Steering is simple enough – you push the bars in the opposite direction you wish to travel. That begins the turn, and the bike leans as it turns. Deliberately turning the bars in the opposite direction of travel is known as countersteering. Counter means ‘against’, and to steer means to ‘guide or direct’. To go right you must turn the bars left – to go left, turn the bars right.” (Code, 1993). This is summed up by the saying “*Press right, lean right, go right*”.

In order to steer a motorcycle the rider must learn to balance the gravitational and centripetal forces by learning which leads to a controlled and stable turn. To establish the correct lean is counter steering i.e. turning the bars counter to the desired turn. Fajans (1999) states an obvious but simplistic explanation “*You may have noticed, however, that while on a bicycle, it is surprisingly difficult to ride clear of a nearby high curb or sharp drop. This is because you must steer towards the edge to get away from the edge.*”

It is recognised (Foale, 2006) that the whole cornering process is not just as simple as a bit of countersteering followed by straightening out at the end. There would appear to be two conflicting theories,

- Gyroscopic or precessional theory – where the majority of the lean in torque comes from the gyroscopic effects.
- Steering out from under or out-tracking theory – which assumes that as the front tyre moves from under the CoG., gravity continues the lean as the steering straightens up.

2.7.2 Limitation to the theory

There are three main gyroscopic effects that come into play when steering a motorcycle. The first of these the 'steering' moment is created when the rider changes direction and it leans the motorcycle away from the direction in which it is being turned.

Figure 3 Steering moment (Cocco, 2005)

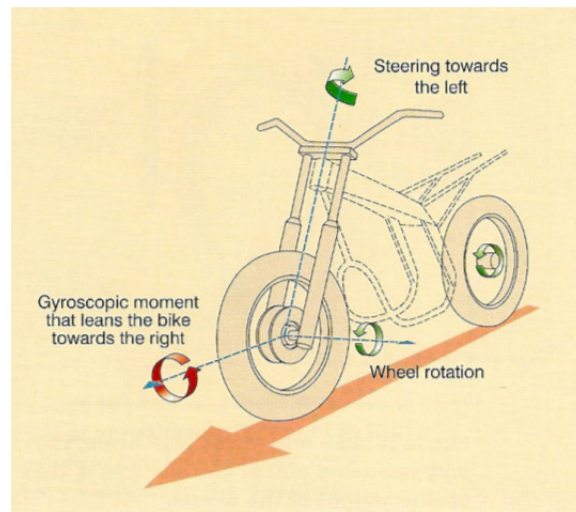

The second the 'roll' moment generates a stabilizing effect and concerns the whole machine. When the machine leans to one side (rolls) with the wheels rotating about their axes there is a moment generated that tries to rotate the whole machine about an axes perpendicular to the ground.

Figure 4 Rolling moment (Cocco, 2005)

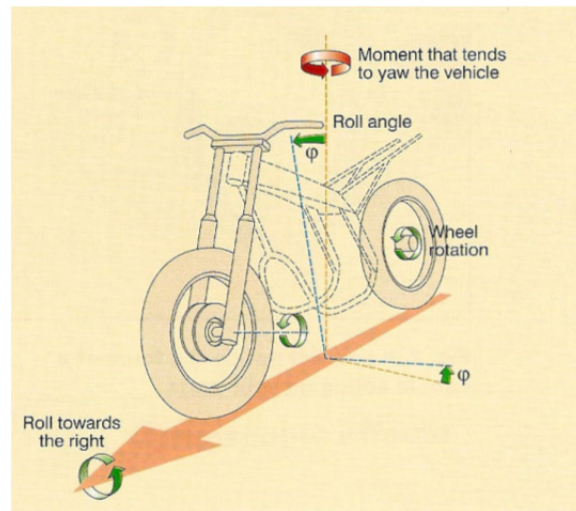

The 'Yaw' moment the third of the gyroscopic effects is again produced by the wheels rotating about their axes but also by the motorcycle rotating around a curve. In this case the moment tends to keep the machine in a vertical position.

Figure 5 Yawing moment (Cocco, 2005)

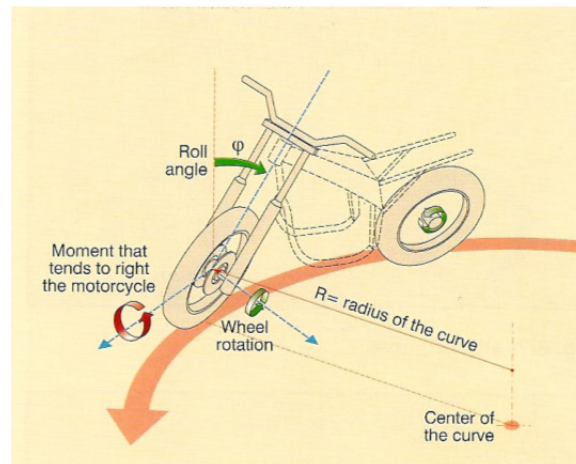

It therefore follows as discussed at paragraph 3.5.1 the faster the machine goes the greater the stabilizing/righting effects. One important element is the gyroscopic effect generated by the rotating crankshaft and fly wheel of the power unit fitted to the motorcycle. The rotational speed of the engine varies from about 800 r.p.m. at idle to 12000 r.p.m when at full speed and therefore the gyroscopic effect is also very variable.

Therefore at slow vehicle speed and low engine speed there is little gyroscopic effect in the system and hence the rider can steer in the direction desired without generating any opposing torque. Additionally the gyroscopic effects vary depending on how the engine is mounted within the motorcycle (Kasanicky et al., 2003). There are two basic configurations;

1. where the engine is mounted transversally across the frame. If the engine rotation is in the same direction as the wheel rotation then the gyroscopic effect of the rear wheel and the engine will mutually reinforce. If the rotation is opposite to the rear wheel then the effect will mutually cancel.
2. where the engine is mounted in line with the frame i.e. the engine rotation is perpendicular to the longitudinal axis of the machine. In this case the gyroscopic effect does not directly affect the steering of the motorcycle. It will however during acceleration or deceleration cause the front to lift or dive.

2.8 Conclusions

The motorcycle is in general a self-steer system, which requires little rider influence to control. The main mode of motorcycle control is free-control, a man-machine system where it is accepted that the ability of the motorcycle rider is a major factor in determining how a modern well-designed motorcycle will respond in various situations. Contributions by the rider are all strongly connected to the design of the steering system and come from mass, inertia, tyre force, tyre movement and the gyroscopic forces acting on the machine, these forces being concentrated at the front of the vehicle and being dependent on speed. It is also true that some of the forces have stabilising effects whilst others have destabilising effects on the vehicle but in general the vehicle is as stated self-steering. However the self-steering capabilities of the modern motorcycle

inevitably lead to oscillations mainly at the front of the machine which inevitably need to be balanced.

As has been seen the rider has an effect on the motorcycle in two ways, firstly the rider is a structural part adding to the mass and inertia of the man-machine system, secondly as a system controller (rider). The control position the rider takes depends strongly on the open loop dynamics of the vehicle as discussed above. The rider cannot control the wobble mode but will have a damping effect dependent on the hold the rider takes of the handlebars. It is possible that there is some influence on weave, in that the rider does have some control on the roll rate, stabilising this for good cornering and general manoeuvring. The rider employs various forms of active control such feedback received from perceived errors/corrections, motion and visual feedback to evaluate the overall condition of the motorcycle in order to close the loop. Once the loop is closed it is possible to apply one of the available control actions such as steer torque, steer angle, rider lean, rider weight shift (lateral body mass move), and of course throttle control. The latter will not only have an effect on the speed of the vehicle but also on the gyroscopic properties of the power unit, a control which although available is one that the novice rider may not be adept at using. Steer torque to roll feedback is by far the most influential way a novice rider controls a motorcycle.

The main research carried out has been to develop a multibody system in order to understand better the dynamics of motorcycles and to use that acquired knowledge to design safer machines. Little has been done to design safer riders, operators who have all the control activities available to them. The complexity of the motorcycle dynamics has been shown and the necessity for optimal control by informed riders has been demonstrated. Without well trained riders even the

most advanced and sophisticated motorcycle design cannot on its own reduce the incidence of rider death and serious life changing injuries.

Chapter 3 **The geometry of motorcycles**

Motorcycles and pedal cycles are both 'single-track vehicles', there are however certain differences between the two, the most obvious of which is that the motorcycle has a power unit and transmission system, making it significantly heavier and able to achieve much higher speeds. However the laws of physics are valid for the stability of both albeit some laws are insignificant for pedal cycles.

As a single track vehicle a motorcycle lacks inherent static balance i.e. it falls over if left to its own devices when stationary. Once moving above a certain speed most riders find that the machine seems to support itself.

Since the 1860's when the first commercial pedal cycles were introduced successive engineers and designers have fixed various power units to the pedal cycle to make it a motorcycle. The first petrol driven machine being arguably the 'Reitwagen' constructed in Germany by Gottlieb Daimler and Wilhelm Maybach in 1885. In the twentieth century motorcycle design accelerated from the introduction of a 239cc motorcycle by the English pedal cycle company Royal Enfield and again in the 1960's Honda introduced their 'CB' range of motorcycles. The image of the motorcycle changed from being a cheap means of transport to that of a leisure toy. However, the overall design style of the motorcycle has not fundamentally changed from the pedal cycle with two wheels of the same size to the present day. It is still composed of essentially two parts, the front steered wheel and the rear frame comprising the power unit, transmission and the rear wheel.

3.1 The Geometry of motorcycles

Motorcycles are complex machines, comprising a large variety and number of parts. A modern day machine can be modelled as an assembly of four rigid bodies.

- The front assembly i.e. the forks, steering head and the handlebars
- the front wheel
- the rear assembly i.e. the motorcycle frame, tank, power unit and transmission and the saddle
- the rear wheel

When considering how many degrees of freedom the motorcycle has, it is convenient to use a spatial mechanism as above e.g. four rigid bodies. Three revolute joints, the steering head and the two wheel axles connect the four rigid bodies. Each of these revolute joints inhibits five degrees of freedom while each tyre contact patch leaves three degrees of freedom free i.e. the ability to rotate around the contact patch on the wheel plane (forward motion), the intersection of the tyre and road planes (roll) and the axis passing through the contact patch and the centre of the wheel (spin).

The four rigid bodies each have 6 degrees of freedom giving a total of (4×6) 24 degrees of freedom. However as discussed there are constraints, the three revolute joints inhibits 5 degrees each giving (3×5) 15 constraints and the tyre-ground inhibits an additional (2×3) , 6 degrees of freedom. Therefore in this scenario the motorcycle only has $(24 - 15 - 6)$, 3 degrees of freedom which may be associated with three principal motions;

- the forward motion of the motorcycle
- roll motion around the straight line connecting the tyre contact patches
- steering rotation

These three degrees of freedom have been derived assuming that the tyres are solid and move without any slippage. This clearly is not the case. The motorcycle generates longitudinal forces during acceleration and braking and also lateral forces depending on the road conditions. The total number of the available degrees of freedom is therefore seven (Cossalter, 2006);

- forward motion of the motorcycle
- rolling motion
- steering rotation
- longitudinal slippage of the front tyre during braking
- longitudinal slippage of the rear tyre during acceleration and braking
- lateral slippage of the front tyre
- lateral slippage of the rear tyre

Motorcycles can be described by using selected geometric parameters of the single-track vehicle when it is in vertical position and the steering angle is at zero.

3.1.1 Centre of gravity

For most purposes the centre of gravity (CoG) is taken as a combination of rider and machine. When considering the position of the centre in two dimensions i.e. the x and z axis's it is important to recognise that if the longitudinal position is moved it significantly affects the action of forces acting on the individual wheels. If the CoG is moved forwards then the control and stability decreases, if however it is moved backwards the load on the front wheel decreases and the controllability of the vehicle increases. If the CoG is moved too far towards the rear then the load on the front wheel decreases to such an extent that it may be necessary to damp the steering to eliminate any adverse effects. A low CoG will improve the handling of the motorcycle at slow speeds and greatly improves it

stability. Conversely a higher CoG position will improve the stability of the motorcycle at higher speeds.

3.1.2 Wheelbase

The wheelbase can be described as the longitudinal distance between the wheel axles or the distance between the centres of the individual tyre contact patches on the road. Wheelbase lengths vary according to the design of the motorcycle. Light weight motorcycles may have wheel base measurements in the region of 1350 mm whereas a large touring type machine may have a wheelbase excess of 1600mm. Wheelbase as stated is the longitudinal distance between the wheel axles but the handling characteristics of motorcycles with the same wheelbase measurements may be totally opposed. In general, considering that other parameters stay constant an increase in wheelbase will be favourable providing

- a reduction of weight transfer during acceleration and braking
- a reduction of pitching generated from uneven mega textures of road surfaces
- greater directional stability

Conversely the increase will prove to be unfavourable increasing

- the magnitude of torque required to turn the handlebars
- the difficulty to steer on turns of reduced radius
- the flex of the motorcycle frame

3.1.3 Steering head angle

Often called the rake or more precisely the caster angle, is the angle between the axis of the steering head and a perpendicular to the road plane (Hillier et al, 2004). The stability of the steering and the front suspension is very sensitive to any change in the caster angle. The front suspension being constructed of a telescopic design is therefore susceptible to flexion and torsion during braking. Hence any small change to the caster angle can cause notable changes to the

stress present at the forks which in turn can generate unfavourable oscillations at the handlebars. The caster angle can range from 19° for a speedway bike to 34° on a touring machine, it is therefore characteristic of the machine's design and use.

3.1.4 Offset

The wheel-spindle offset is the distance measured perpendicularly from the steering axis to the centre of the front wheel spindle. Generally offset is achieved by the use of triple clamps but it is also possible to create offset by lugs fixed to the forks. Offset can therefore be positive, wheel axis in front of the steering axis or negative with the wheel axis behind the steering axis or neutral when the wheel axis is located on the steering axis. All motorcycle manufacturers now produce machines with positive offset i.e. the wheel centre is forward of the steering axis.

Figure 6 Offset and Trail

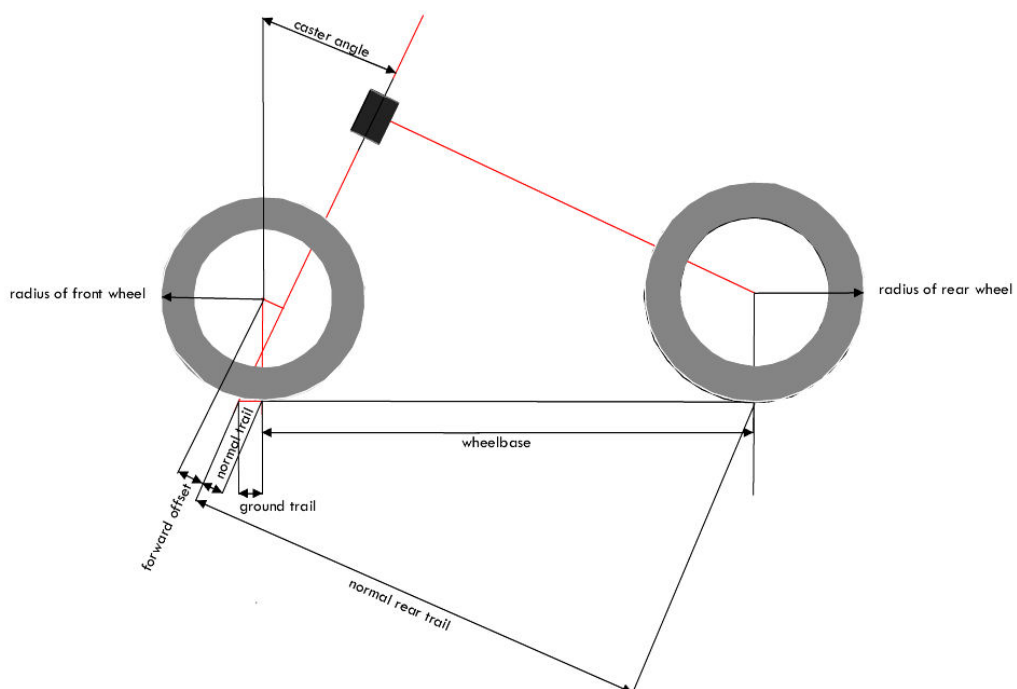

3.1.5 Trail

There are two trails associated with a motorcycle. The first of these, ground trail is the longitudinal distance (a) from the centre of the front tyre / road contact patch and the point where the steering axis meets the ground. The rear wheel trail is a measurement taken from the intercept point of the steering axis and the road to the centre of the rear tyre contact patch. The second, the normal or real trail (b_n) is measured at right angles to the steering axis for both the front and rear wheels. The trail is positive when the centre of the tyre contact patch is behind the point of intersection of the steering axis with the road surface (Heisler, 2002). It therefore follows that the front wheel trail can be positive, neutral or negative depending on the caster angle and the offset values. The rear real trail is always positive. If all other parameters are kept constant, then an increase in wheel radius will also increase the trail. The classical steering mechanism of a motorcycle taken from a geometrical view point can be described by the previous two parameters i.e. the caster angle and the fork offset. Using these two parameters together with the wheel radius it now makes it possible to calculate the ground (front) trail of the motorcycle.

$$a = a_n / \cos\theta, \quad \text{where } \theta \text{ is the caster angle and } a_n \text{ is normal trail}$$

3.1.6 Combining caster angle and offset to produce trail

Having defined caster angle and offset it is clear that trail can be obtained by a combination of caster angle and offset. It is therefore possible to obtain the same trail by a combination of caster angle and offset.

3.2 The righting moment produced by trail

The primary function of trail is to produce a righting or stabilising force about the contact patch / point. The contact patches of both the front and rear tyre lie behind the point where the steering axis meets the ground, this gives rise to a

caster (self-centring) effect. If the motorcycle is considered to be travelling in a straight line with velocity V on level ground the vehicle will be vertical. If a side force is applied to the left hand side of the vehicle, such as a gust of wind there will be a slight rotation of the front wheel to the right. Once the wheel turns the tyre contact will rotate about the steering axis causing the ground trail to shorten from a to a' .

Figure 7 Righting moment produced by trail

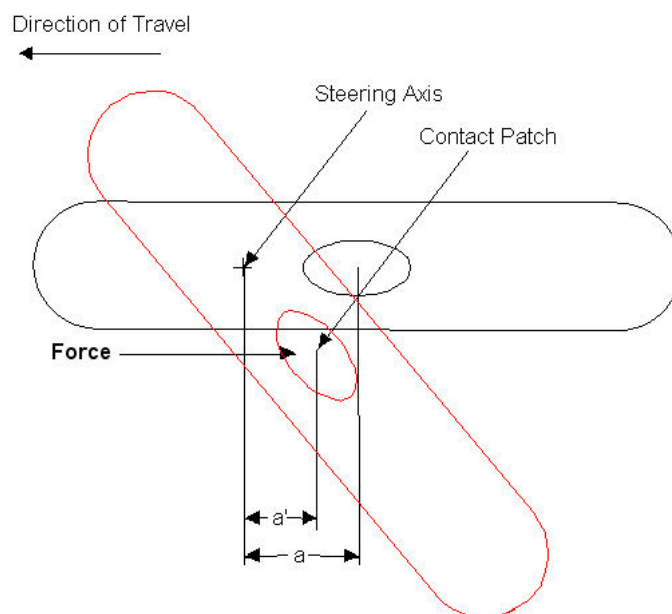

Ignoring the fact that the motorcycle will start to turn left and due to centripetal forces the machine starts to bank to the right, it is possible to consider the displaced contact patch to also be travelling at velocity V and in the same initial direction.

The vector V can now be resolved into two orthogonal vectors, $\omega_f R_f$ the rolling velocity which is placed in the plane of the wheel, and V_{slide} the sliding velocity of the contact patch with respect to the road plane. The frictional force F acts directly opposed to the V_{slide} . Since the trail is positive the frictional force F generates a righting moment (which is proportional to the value of the normal trail), that tends to align the front wheel and this moment has a stabilising effect.

If the same exercise is conducted when the trail is negative i.e. the tyre contact patch is in front of the point where the steering axis meets the ground, the frictional force F which will still be opposite V_{slide} , the generated moment will not be a righting moment but a destabilising moment that will tend to increase the force turning the steering to the left.

The righting moment or caster effect, which is proportional to the value of normal trail is affected by any increase in the rake or caster angle. The moment arm is along the line of normal trail and hence has the same length i.e. length a_n the normal trail.

The following diagrams show the three possible trail considerations, negative, neutral and positive. In the negative trail scenario the intersection point of the steering head axis is behind the perpendicular through the wheel axis, in the neutral condition the steering head axis and the perpendicular are coalesced and in the positive condition the intersection of the steering head axis is in front of the perpendicular.

Figure 8 Negative, neutral and positive trail

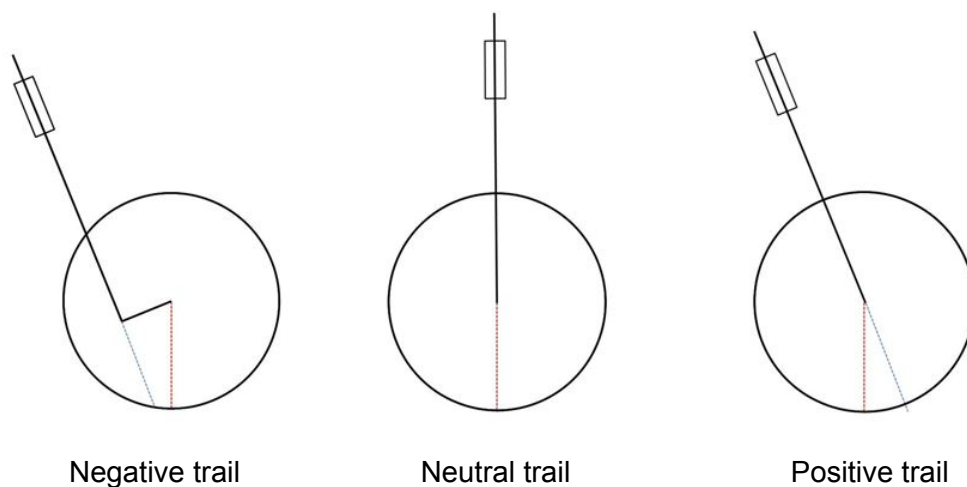

At figure 7 the righting moment was considered for the positive condition, if the force is acting at the tyre contact patch is in front of or coalesced with the contact patch then the effect will be either destabilising or indifferent.

It is also necessary to consider the forces acting on the rear tyre contact patch when there is a rotation of the steering axis. The rear trail is much greater than the front but the slip angle due to V_{slide} the actual rotation of the rear wheel is very small and the value of b_n is small. The stabilising effect on the rear wheel compared to the front is very much less significant. The moments at the steering head axis are proportional to the distances a_n and b_n which are related to the wheelbase p and the front ground trail a by the equations

$$a_n = a \cos \Theta \quad \text{and} \quad b_n = (a+p) \cos \Theta$$

When riding in a straight line this stabilising moment will be generated when any slight steering input due to road surface undulations, side wind, wet roads etc. The steering of motorcycles is very sensitive to any small input thus the greater the trail the more stable the motorcycle will be however the manoeuvrability of the machine will be reduced.

3.3 Steering-head drop and camber angle

When steering is applied to a machine held vertical with positive trail and a positive trail, the steering-head will drop. To demonstrate this consider a system with extreme caster angle say 90° the effect of steering on the steering-head is quite obvious. The steering head will drop as the handlebars are turned. Obviously with a smaller caster angle the effect is much less dramatic but this drop in the steering head also shortens the trail. Therefore during braking or during a swerve where a force impulse is exerted at the contact patch the

steering head will drop thus changing the handling characteristics of the motorcycle's steering.

Figure 9 Steering head drop

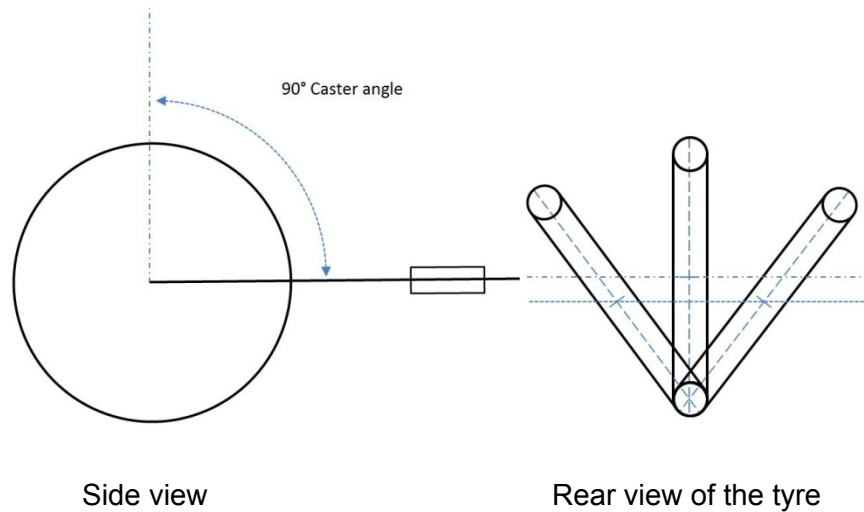

3.4 The steering torque

In order to maintain the motorcycle in rectilinear motion the rider must maintain the equilibrium of moments around the steering axis. This becomes more complex when considering a transitory movement where the velocity and radius of turn are variable. The torque applied by the rider must therefore be equal to the sum of all the moments generated by the forces acting at the front of the motorcycle. Therefore by definition the steering torque input by the rider will be positive provided it increases the steering angle into a turn.

As a single track vehicle a motorcycle lacks inherent static balance i.e. it falls over if left to its own devices when stationary. It is therefore useful to consider the problem of balance and steering before defining the components of torque acting on the steering axis. Once moving above a certain speed most riders find that the machine seems to support itself. Therefore it seems that there are two aspects to the balance problem;

- Low speed
- Higher speeds

At low speed most of us use and require some forward motion, there are however those who can maintain balance whilst stationary.

At low speeds the torque is negative due to the forces acting at the tyre / road contact point because these forces assist the motorcycle to turn once it leaves rectilinear motion i.e. it will fall over. The rider must therefore restrain or block the steering otherwise the steering will continue to rotate. Once the torque becomes strongly negative the easier the machine turns into a bend.

As the velocity of the motorcycle increases the steering torque will become positive due to the righting moments generated at the front of the motorcycle. If the torque continues to increase the machine becomes difficult to ride and the machine does not easily bank over to enter into tight turns.

There are six components of torque which act on the steering axis through the motorcycle headstock;

- the vertical load generates a high value positive misaligning moment.
- the lateral force generates a high value negative righting moment.
- the weight force acting at the front centre of gravity produces a positive misaligning moment.
- the centripetal force is a negative righting moment similar in magnitude to the weight force.
- the gyroscopic moment produced is also a righting moment.
- the twisting moment generated at the contact point is a misaligning moment that will increase with the roll of the motorcycle as it enters the turn.

3.5 The gyroscopic effects

Once moving above a certain speed most riders find that the motorcycle seems to support itself.

When considering the front wheel of the motorcycle as a gyroscope there are three moments which act on the front of the motorcycle when the steering is turned. The effects of the gyroscope can best be described in relation to the inertial moment of the wheel spinning around its axis, the rotational velocity which is applied to the spin axis and the resultant force which will act orthogonally to the first two. The overall effect is termed the gyroscopic precession and this moment is defined by:-

$$Mg = I_r \times \omega_r \times \omega_s, \text{ where:}$$

I_r is the inertia of the wheel spinning on its axis

ω_r is the rotational velocity about the spin axis

ω_s is the velocity at which the spin axis is rotated on the plane of the axle (the precessional axis).

Figure 10 Gyroscopic precession

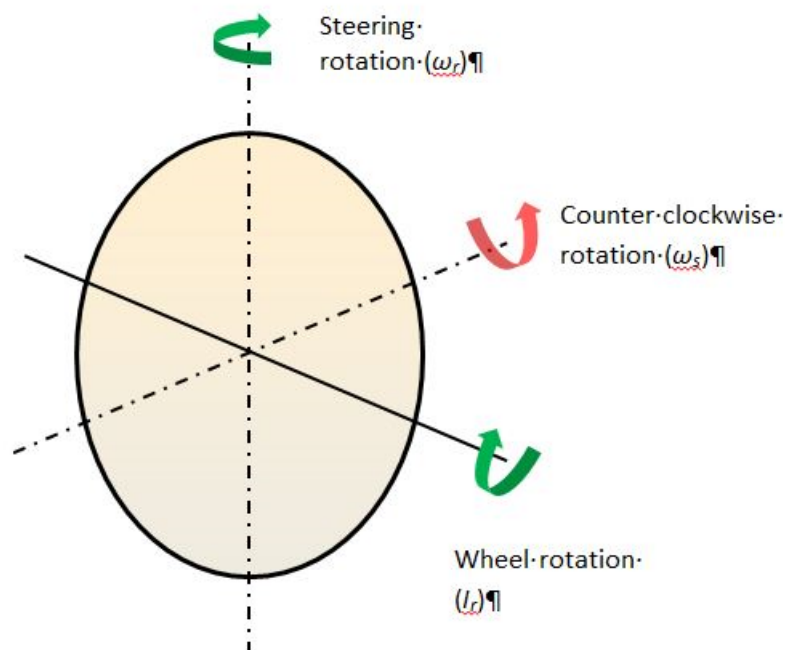

When a wheel is spinning as in figure 10 above and it is steered to the right, it will tilt strongly to the left. However, if it is tilted to the right it will steer to the right.

3.5.1 The moments generated and their effect on the motorcycle and rider

- The Steering moment

This moment relates to the front wheel as the steering is being turned. The wheel is spinning around its own axis and at the same time is being turned by the rider when changing direction. The moment generated tends to lean the bike away from the steered direction, making the turn more difficult.

- Rolling moment

The second moment produces a stabilising effect on the machine. This rolling moment, concerns the motorcycle as a whole. Assuming the steering is locked, whenever the bike leans to one side, with the wheels continually rotating around their axis, the moment that is generated tends to roll the whole machine around an axis that is perpendicular to the ground i.e. the Z axis. If the rider could hold the handlebars straight, the reaction of the tyres at tyre road interface tends to right the machine to the vertical position.

- Yawing moment

The yaw moment is created during turns and is also a stabilising effect: This effect is produced by both wheels they rotate around the centre of the curve. This 'yaw' moment tends to keep the bike in a vertical position.

The suggestion is therefore that the faster that the vehicle travels, the more the gyroscopic effect helps to maintain the balance and control of the motorcycle moving in rectilinear motion.

The engine with all its rotating parts will also produce a significant gyroscopic contribution which cannot be ignored. The crankshaft which may run either

parallel to or transverse to the axis of the wheels will have an effect on the overall balance and stability. Considering the crankshaft and flywheel of a 600cc motorcycle running parallel to the wheel axles we can note;

- Their combined weight is comparable to the weight of a wheel
- The diameter is clearly smaller than a wheel
- The rotational speed can be very much higher 800 to 12000rpm
- As a consequence, the gyroscopic effect is also very variable, a small value when idling, but a large one when the engine is revved up.

This suggests that at low speeds and high engine revs there is a strong gyroscopic effect which helps the rider maintains stability provided the rider understands what he / she is doing. Conversely at low speed and low engine speed the stability and balance must be a function of rider's ability to balance.

In conclusion, the gyroscopic phenomenon does indeed contribute to transforming the motorcycle into a perfectly controllable means of transport and may if used to the riders advantage help towards protecting the rider in certain avoidance manoeuvres (Gray, 1918).

Chapter 4 The Questionnaire Results

The questionnaire (Appendix 4) was designed to sample as broad a spectrum of riders as possible in an attempt to identify if they understood the basics of counter steering, how it affects the rider and if they had undertaken any form of training. The sample was to include various styles and sizes of motorcycle together with the type of riding the owner participated in i.e. road, track and green lane. Clearly the sample could not be infinite and therefore it would be a sample from the population. The sample needed to fit a normal distribution if at all possible, in order to give as far as possible, a fair representation of the population.

After the removal of any spoilt returns and those where evidence was missing a data set of $n = 274$ was finally achieved and analysed.

4.1 Involvement in swerve to avoid incidents.

To address the first aim of this initial research it was determined that forty five per cent of those questioned had in fact been involved in a swerve-to-avoid incident. Thirty per cent of the total sample had been taught counter steering to some degree and of those trained, thirty nine per cent had been involved in a swerve- to- avoid incident after training.

Placing the data into a simple two-way contingency table (Table 1), it appears that training is independent of swerve/avoid.

Table 1 Two-way contingency table

Swerve /avoid	Trained		Row totals
	Yes	No	
Yes	32	90	122
No	51	101	152
Column totals	83	191	274

The data collected was analysed by way of a two-way contingency table and by setting up a log-linear model looking for evidence of association between the two discrete variables involved. GenStat, a statistical program by VSN International Limited, was used for this analysis. This particular software allows a choice of two different test statistics for the chi-squared test. The usual method developed by Karl Pearson

$$\sum \frac{(O_i - E_i)^2}{E_i}$$

or a Maximum Likelihood method which is actually the residual deviance from fitting a log-linear model

$$2 \sum O_i \log\left(\frac{O_i}{E_i}\right)$$

The significance probability (SP) is the probability of obtaining the observed results given that the null hypothesis is true and this is measured using a test statistic. Analysis by chi-squared using either the Pearson or maximum likelihood methods does result in small test statistics and relatively large SP's ($p > 0.05$).

Pearson chi-square value is 1.72 with 1 df.

Probability level (under null hypothesis) $p = 0.190$

Likelihood chi-square value is 1.73 with 1 df.

Probability level (under null hypothesis) $p = 0.188$

Either way, there is only weak evidence of an association between training and swerve-to-avoid. The full GenStat results are at Appendix 5.

For those riders who had not been taught, forty seven per cent had suffered a swerve to avoid incident compared to those who had been trained, where only thirty nine per cent were involved.

The second part of the research aim concerns the type of riding that the participants were involved in. A comparison of riders who ride only on the road and those who participated in track or green lane events revealed that seventy one per cent of the sample restricted their riding to the road, sixteen per cent rode on the road and track, eight per cent rode on the road and green lane but only four per cent rode road, track and green lane (figure 11 on the following page).

Figure 11 Discipline of riders in questionnaire

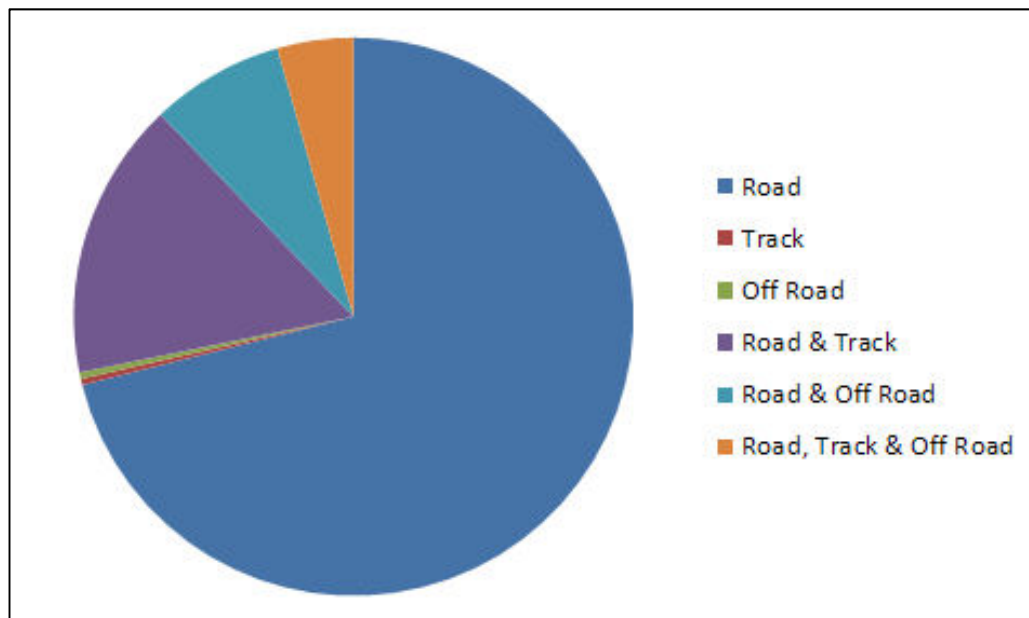

For the 71% who only rode on the road, there was a 76% to 24% split between untrained and trained. This revealed that, of those untrained riders, forty four per cent had been involved in the swerve- to- avoid incident whereas only thirteen per cent of those who had some form of training were involved. When comparing the same analyses to those who rode both on the road and the track, there was strong similarity in whether the rider was trained or not, sixty per cent of the untrained were involved and sixteen per cent of those trained were also involved in swerve to avoid incidents.

The type of riding participated in may have some educational effect on the rider whether it be consciously or subconsciously. The following graphs, figure 12 & 13 show the number of riders participating in their disciplines and the number of swerve to avoid scenarios they have experienced both before and after training. figure 12 shows the number of riders who have not undertaken any training in counter steering and the number of incidents each group of riders have sustained.

Figure 12 Untrained Riders - Number of Swerves / Avoids

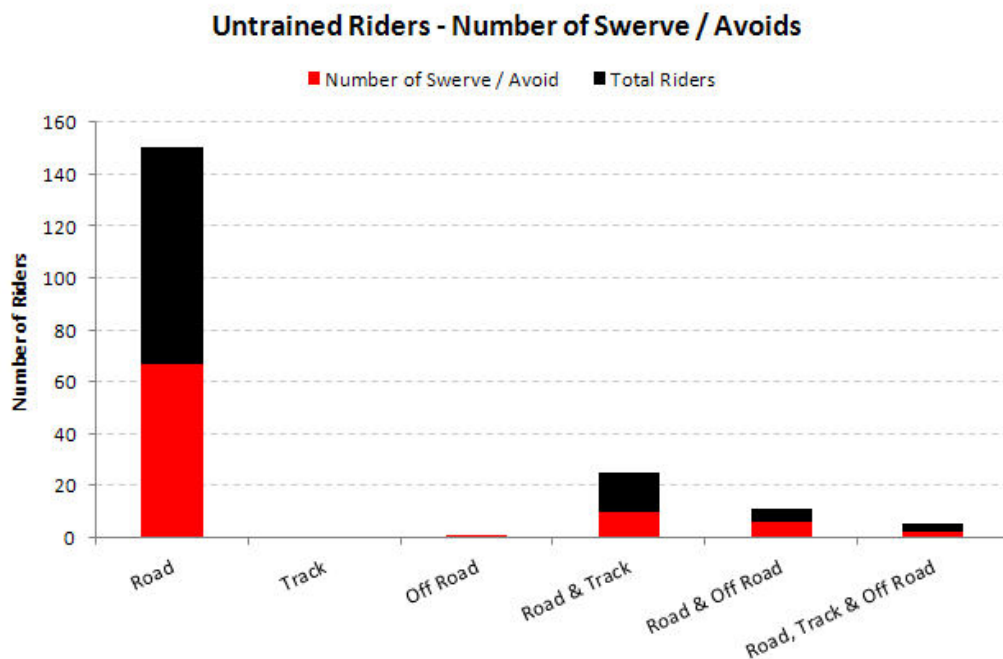
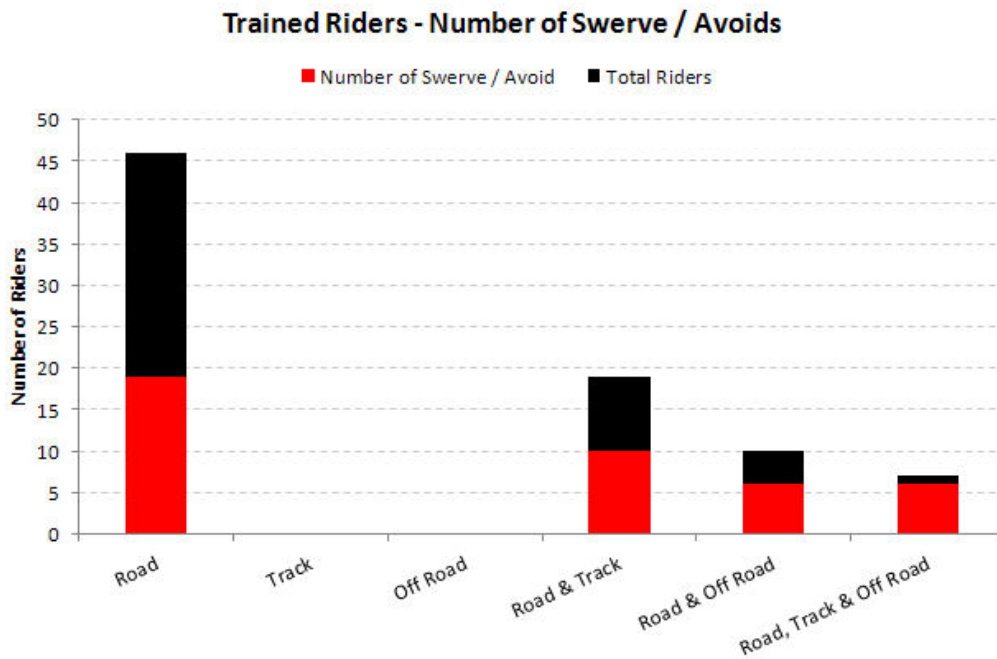

Figure 13 shows the breakdown for the trained riders in the questionnaire.

Figure 13 Trained Riders - Number of Swerves / Avoids



Examination of the data relating to all rider disciplines shows reductions in the number of incidents of swerve to avoid for the trained riders. It must be considered that there may be other causal factors involved e.g. the speeds of the vehicles involved, weather conditions and conspicuity.

4.2 Passing the test

The old Department of Transport test (DOT) accounted for forty six per cent of the sample, whilst thirty one per cent had undertaken Compulsory Basic Training (CBT) and twenty three per cent had qualified by the Direct Access route. Of these three training methods, fifty three per cent of those who passed their test by the old DOT had been involved in a swerve- to- avoid compared to forty three per cent who trained with the CBT and forty four per cent who passed via the Direct Access route.

4.3 Countersteering Training

Of the eighty three riders trained in counter steering, four were trained in the 1970s, seventeen riders underwent training in the 1980s, twenty five were

trained in the 1990s and thirty five had been trained from the start of the year 2000 (two riders failed to give details of their training).

Of the eighty three riders trained in counter steering there is nearly a 50% split in their initial training method. Although the majority are from the DOT test there is a relatively even split between the other two training methods. There is therefore the possibility that the 'older aged' rider is more likely to invest in additional training. The age at which riders undertook training or at what stage of their motorcycling career has not been investigated however the inference can be made since 1990 it has been impossible to obtain a full motorcycle licence without participation in the CBT. Individual courses or course content has not formed any part of this research other than to identify that the training varies across the board and ranges in length from half a day to five days.

Figure 14 Qualification test prior to countersteering training

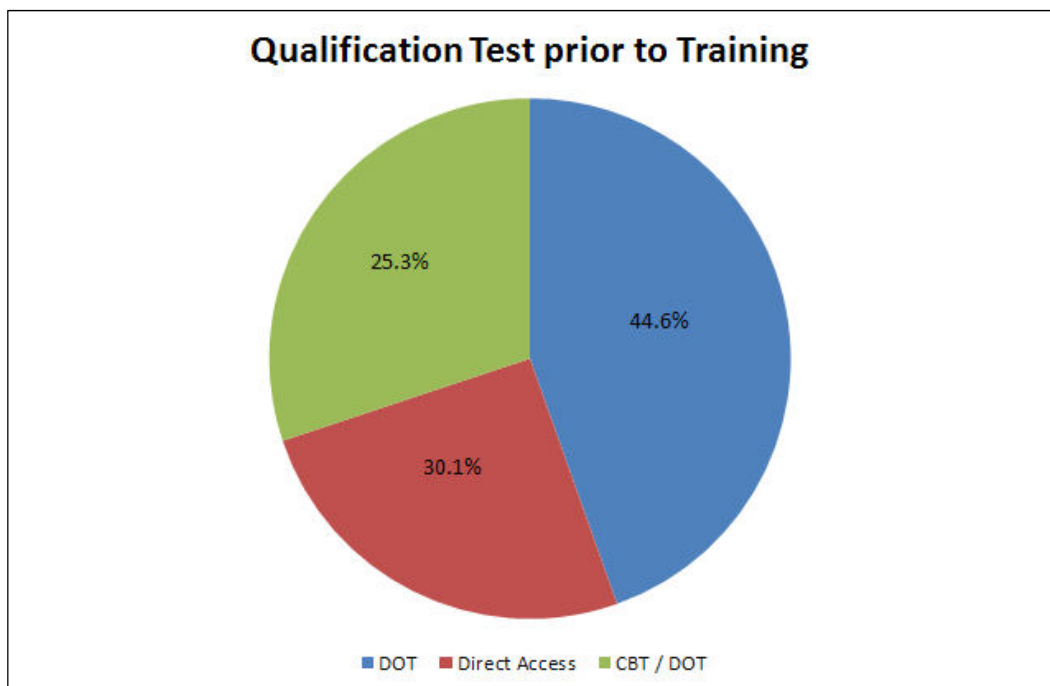

Counter steering training identified for this research shows that it was acquired either during basic, advanced or specialist courses. Some advanced courses

which specialise in counter steering, do include off-road modules and hazard avoidance techniques.

4.4 Rider misconceptions

Fundamental to any training is the understanding the student takes away from the course being undertaken.

The majority of riders (trained or untrained) it would appear are familiar with the term 'counter steering' and they know it has something to do with how the machine is steered. Surprisingly a large percentage knew what force is acting but the effect those forces have on the motorcycle is not fully understood.

In order to determine exactly what riders understood about counter steering, those who were questioned were asked to select what they believed it was. The following table shows a breakdown of the responses to the two questions asked;

1. What do you understand by the term counter steering?
2. Does it allow you to?

Table 2 Understanding of countersteering

		Un trained	Trained
1.	Gyroscopic effect	73 (38%)	39 (47%)
	Different way of steering	99 (52%)	30 (36%)
	Specific frame design	0	0
	None of these	19 (10%)	14 (17%)
2.	Corner more safely	101 (53%)	49 (59%)
	Avoidance technique	37 (19%)	11 (13%)
	Ride faster	10 (5%)	7 (9%)
	None of these	43 (23%)	16 (19%)

The majority of the untrained riders believed it was either a 'Different way of steering' or a 'Gyroscopic effect' with a roughly even split between the two. However ten per cent of the data set did not know what it was. This level of understanding is more than acceptable as the questionnaire does not consider the academic level of the riders.

When asked to decide what it allowed riders to do, over half said it allowed riders to corner more safely and 19% believed it was an avoidance technique! Nearly one quarter opted for 'none of these', but was that because they were not certain of the answer in the first place.

However, when the responses given by the trained riders are considered they do raise concerns as to the level of understanding taken away from their instruction. Only 47% identified that countersteering involved a gyroscopic effect and worryingly 36% said it was a different way of steering. This was followed by 59% believing that it allowed riders to corner more safely with only 13% recognising countersteering as an avoidance technique. Even more worrying was that 19% opted for 'none of these'.

If this is a true reflection of the motorcycle instruction that is being delivered, it would appear that the basics of motorcycle steering are not being understood.

4.5 Discussion

The major concern must be that motorcycle riders are 'dying' from being involved in swerve to avoid collisions and although individual collisions have not been specifically investigated within this particular research, it is possible according to 'The Hurt Report' (Hurt et al., 1981) that some of these incidents could have been avoided. The findings of 'Hurt' suggest that the rider's ability to countersteer and swerve was essentially absent. It therefore follows that if the

motorcycle training were to include counter steering and swerve, that the killed, seriously injured (KSI) rate should fall.

The results from this initial research do suggest that those riders who have undertaken additional training (no matter what the length or quality of the training) experience fewer swerve to avoid incidents. It is of interest to note that this is evident in all rider groups.

There do appear to be two groups that 'should know better' i.e. the road/track and off road riders. It seems reasonable to assume that the track riders would research their chosen sport as any athlete would do i.e. to become better and to achieve success requires extra training. Therefore, to succeed on the race track requires the rider to study how to steer more effectively and to understand that the motorcycle is relatively stable until steering is applied and becomes stable again once the steering is removed. In the 'un-trained' group of road/track riders there is a high incident rate of 'swerve to avoid' but this is reduced in the 'trained' group. One explanation is that the questionnaire does not identify the riders who enjoy 'track days' (the opportunity to ride a particular circuit) as opposed to track racing.

Off road and green lane riders would be expected to have good steering control and be able to maximise machine stability, but this does not appear to be the case for the untrained rider once they take to the open road. The ability to maintain balance and control at very slow speed on a pedal cycle essentially requires the rider to continually apply slight steering inputs left and right. Once speed increases, even marginally, this requirement to steer begins to fall away. The same is true for the motorcycle, but do sport riders choose different motorcycles designed for their discipline? i.e. machines with specific 'rake' and

'trail' or is it that they unwittingly realise that if the engine is revved up, the machine is steadier and more stable. In other words, at slow speed there is no need to countersteer, provided the rider keeps the motor revved the gyroscopic effect relating to its rotating masses is strong and assists in keeping the motorcycle upright and going in a straight line. However, once on the open road and the speed has increased this ability the rider has at slower speeds is no longer used and the rider reverts to norm.

In any formal advanced motorcycle instruction is it essential that students actually understand the physics behind the techniques, provided they know how to steer?

It is quite clear from the elementary training required to ride a pedal cycle that below a certain speed there is no need to countersteer, we just turn the handlebars in the direction we want to go. Once over a certain threshold speed the requirement to turn the handlebars diminishes and it is possible to 'lean into' the turn or even ride without having any physical control of the handlebars (look no hands). Depending on the design of the machine, various 'rake angles' and 'trail' lengths, the speed will vary at which counter steering becomes effective. What is the magnitude of difference in the speed at which the rider of one model/make of machine will stop turning the handlebars in the direction of travel and start to countersteer? How fast do novice riders have to ride during training to achieve the benefits of instruction? If a common threshold speed could be determined for both the untrained and the trained rider where counter steering is evident and the basic turn to steer element is no longer employed surely this must be the speed at which any 'testing' for qualification to ride on the road must be levelled.

Although the Driver Standards Authority (DSA) set qualification levels for motorcycle instructors who are employed to teach the student to pass the 'test',

once riders are qualified they are free to attend any training centre offering advanced training and these trainers do not have to be DSA approved. The police 'Bike Safe' initiative which is run by individual police forces is a none training experience, where police riders conduct 'observed rides', these police riders are not all police motorcycle instructors and they are only making observations on a member of the public's riding style/ability i.e. if they saw that person riding in the same manner whilst they were on patrol, would they stop and have words with that rider! Counter steering is not a subject in the DSA publication 'The Official DSA Guide to Riding the essential skills'(The Driving Standards Agency, 2008) *per se* and it is not included in the police rider training syllabus.

Chapter 5 **Experimental Design**

5.1 The test motorcycle

The decision to choose a particular motorcycle for the research was extremely difficult. The machine chosen had to be suitable for novice and expert rider alike. The novice rider needs a machine that is easily controllable and not too heavy, whilst the expert rider would be happy with a high power output sports machine. Crucially important are the ergonomics of the riding position. To remove as many external factors as possible, the rider needed to be upright and the rider's hips to be in a neutral position. Consideration was given to the use of a medium sized tourer or a sports bike. Eventually however, the decision was made to settle for a rather nondescript shaft driven machine which had reasonable power; a bike that was easily controllable and capable of being ridden by various riders: male or female, large or small, novice or expert. In other words the test bike should be a versatile, general purpose street machine. The 'standard' or 'general purpose' machine is recognised primarily by the rider's upright position, a position between the slightly reclined position of the cruiser/tourer and the forward leaning position on a sports bike.

5.1.1 Riding Posture

Of the three riding positions mentioned above, the standard position, the first image figure 15, is the most neutral. The rider's body is upright. The head and eyes are up, looking through the path of travel. The arms must be extended but not hyperextended otherwise the hands will not rest comfortably on the grips. There should be enough slack for the elbows to remain slightly bent but relaxed. The knees should rest against the fuel tank and be bent at a height that is slightly lower than the hips, with the feet positioned almost below the knees. In general this position provides excellent visibility and access to all controls. The

rider's foot pegs are more or less vertically in line with or slightly in front of the shoulders.

Figure 15 Riding positions for the cruiser, standard and sports motorcycles

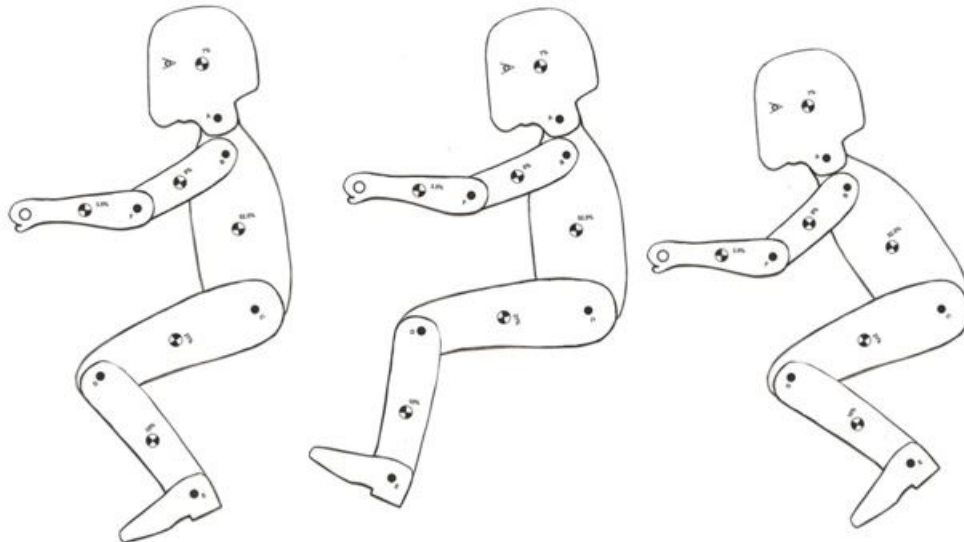

The other two riding positions allow the rider to accommodate the extremes of motorcycle design. The cruiser position tends to be a more relaxed look where the body can be slightly reclined. The feet are in front of the shins and if the motorcycle is fitted with additional foot pegs the leg position can be varied. This seating position gives good visibility but can be tiring on the arms and shoulders as the arms may be overextended to reach the handlebars.

The sports position demands the forward lean, lowering the body profile and reducing wind drag. This places more weight onto the arms and wrists which is magnified when riding at slow speed i.e. at high speed the wind tends to lift the body reducing the body weight supported by the wrists. The feet are behind the knees and the position can be cramped especially for taller riders and during long journeys.

An additional consideration was the 'lag' and forces produced when the rider either accelerated or coasted and relaxed the power before again taking up the

drive. The issue was considered to be most important with regard to the inexperienced rider because it is essential to maintain a constant speed throughout the test exercise. In most cases, the engine is attached rigidly to the frame with the rear wheel being mounted in the swingarm which in turn is pivoted on the rear of the frame in such a way that any irregularities in the road surface may be absorbed by the oscillation of the swingarm. Therefore because the rear wheel shifts position with respect to the frame a system is required that allows the torque of the engine power to be transmitted to the rear wheel that both allows and absorbs movement between frame and wheel. Two methods commonly adopted are:-

- chain/gear or belt-drive
- shaft drive

5.1.2 Power to weight ratio

Consideration was initially given to using either a medium sized tourer or a sports bike. The corresponding power to weight ratio would be in the region of 0.3kW/kg for a Honda VFR 800cc machine to 0.65kW/kg for a Yamaha YZF R1 1000cc. It was considered unrealistic and irresponsible to expect a novice rider to handle machines within this range. Typical modern 125cc machines which 16 year olds are allowed to ride, have power to weight ratio in the region of 0.06kW/kg to 0.08kW/kg. It was more realistic therefore to select a machine within the overall range of 0.06kW/kg and 0.65kW/kg i.e. a machine with a power to weight ratio in the region of 0.3kW/kg. A motorcycle capable of being ridden by novice or expert alike.

5.1.3 The chain/gear or belt drive system

Since the engine sprocket is not on the axis of the swingarm pivot, the chain's total length must vary during the range of movement of wheel motion. The length of the chain/belt is at its greatest when the engine sprocket, the fork axis and the wheel axis are aligned. This condition is achieved when the suspension is in mid-travel and it therefore follows that the chain/belt must have minimal play at the greatest length and will be somewhat slack in all other conditions.

The fact that the chain is not always tight will create some problems for the continuity of motion. When a rider accelerates and the engine rotational speeds increase, the angular momentum also increases and strengthens the 'righting' moment of inertia (Kimishima et al., 1997). At first, the slack must be taken up in the chain and during this phase there will be no proportional increase of wheel speed. Once the slack has been taken up and the chain has extended will there be any transmission of driving force to the rear wheel, which will be subjected to a sudden acceleration. This sudden acceleration due to the driving force will inevitably be recorded as a jerky motion both in riding sensation and 'g' force. Importantly this effect is present not only in acceleration but also in any relaxation due to rider input or road conditions.

5.1.4 The shaft drive system

Shaft drive systems are characterised by: a transmission shaft, up to the swing arm pivot and longitudinal to the motorcycle; a universal joint coinciding with the swing arm pivot and a pair of bevel gears that rotate the drive through 90 degrees at the wheel axis. If the engine's transmission is transverse to the axis of the machine it is also necessary to have an additional pair of bevel gears. In this system, play is eliminated from the transmission system apart from that in the universal joints and couplings. However due to precision with which the bevel gears and universal joints are manufactured this is kept to a minimum.

5.1.5 Suitability for instrumentation

No matter which make or model of motorcycle was selected for the research it had to be suitable for the fitment of a data acquisition system and any associated sensors. The machine therefore should ideally be a 'naked' bike i.e. one with limited fairing which allows easy access to the headstock and forks, does not have an intricate handlebar system and allows easy access to a 12 volt power supply. Importantly the design must allow the DAQ and instruments to be securely mounted and not subject to any undue vibration.

5.2 Conclusion

Table 3 below show that the motorcycle that fitted the test criteria and which was chosen for this research was the Kawasaki GT550 (553cc engine).

Table 3 Requirements for test motorcycle

Requirement	Kawasaki GT550
General purpose machine	✓
Neutral seating position	✓
Power to weight ratio approximately 0.3kW/kg	✓
Shaft drive transmission	✓
Reliable & smooth 4 cylinder engine	✓
Easily modified (if required)	✓
Secure vibration free instrumentation mounting	✓

This motorcycle is a 'standard' general purpose medium sized street machine which produces 44.1 kW (60 horse power) and has a power to weight ratio of 0.22kW/kg. The GT550 model has a dry weight of 201kg, an overall length of 2230mm with a wheel base of 1475mm and is a shaft-driven motorcycle. A suitable low mileage 1996 model (registered 26164 miles, an average of only 2379 miles per year) already fitted with engine protection bars in case of capsizes which had not been ridden on the road since its last Ministry of Transport Test (MOT) in August 2007 was identified and purchased. For full vehicle specification see appendix 6. The machine was subsequently booked

into a test centre for a new MOT which it passed without any mechanical work or adjustments being undertaken.

Due to the age of the motorcycle purchased although low mileage, it was not known if there was any wear within the steering, braking and suspension systems. To reduce the possibility that adverse 'noise' generated by general mechanical wear (not identified during a routine MOT) may be detected by the proposed sensors and DAQ the machine was subjected to a detailed technical examination. The purpose of the examination was to ensure that all steering, suspension, transmission and brake components were within the manufacturer's tolerances. Therefore any adverse noise would not be attributed to the mechanical condition of the machine due to its age.

As a bonus (which was not considered during the evaluation phase) this model of motorcycle is fitted as standard with a small very rigid luggage rack to the rear of the seat which made for ease of mounting of a DAQ system and importantly easy access during test conditions.

Figure 16 Kawasaki GT550 motorcycle



5.3 The initial test course

The initial test course design was a simple serpentine curve consisting of a straight approach into a 90 degree right turn followed immediately by a 90 degree turn to the left and a straight exit parallel to the approach straight. The target speed for the manoeuvre was 30mph (13.41ms^{-1}) therefore to ensure riders could achieve this speed without harsh acceleration the initial straight measured 20m, which on a suitable surface equates to an acceleration rate of approximately 0.46g. At the end of this straight the course followed a right turn along a radius of 10m through 90 degrees before turning left again along a radius of 10m through 90 degrees. The course then continued for 20m along a straight which ran parallel to the entry straight, this final 20m straight allowed the rider to bring the motorcycle to a controlled stop without harsh braking. The track was 1.5m wide and clearly defined by two rows of road cones placed at 5m intervals on the straights and at approximately 3.5m intervals on the curves. It was recognised at this early stage that the maximum speed riders' would negotiate the changes in direction would be in the region of 20mph (8.9ms^{-1}). In order to negotiate the change in direction at 30mph (13.41ms^{-1}) the radius of turn would have to be increased to 23m, increasing the width of the course to 46 metres. Due to constraints in relation to identifying suitable test areas it was decided to test this initial course design.

Figure 17 The original serpentine test course

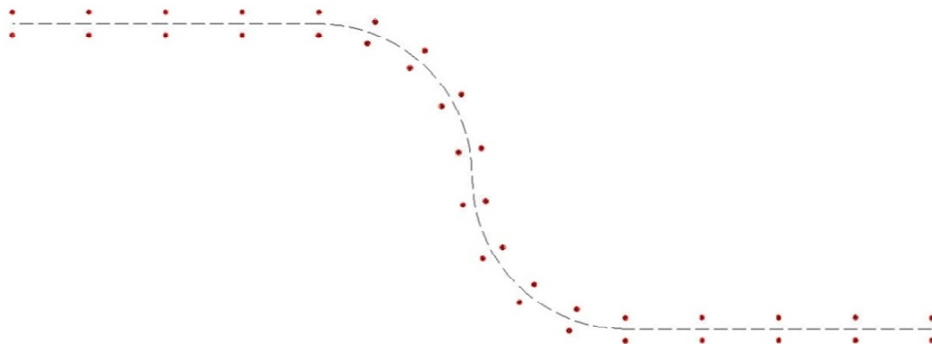

The cones were placed centrally over the measured markings and considering the overall size of the cones there was very little reduction to the available space due to the overall track width and the longitudinal cross sectional configuration (◇ shape) of a single track vehicle. The overall size of the test area (not including the initial area required to get up to speed) was 60 metres long by 21.5 metres wide (Appendix 7).

5.4 Riders

In order to recruit test riders an approach was made to those attending the venue asking for volunteers to assist with research in relation to how motorcycles are steered. The purpose was deliberately left vague so that the rider did not feel that it was he or she who was being evaluated. Although this approach to recruitment ensured that a good population sample was obtained, it was then necessary for participants to complete additional rider information *pro formas* for later categorisation and data analysis.

The volunteer test riders were comprehensively briefed as to what they were required to do during the test and then subjected out of necessity to the rigorous DAQ set-up procedure. In order that the DAQ could be correctly calibrated the height of the sensor plane above ground level was required to be entered. This required each rider in turn to sit and balance on the motorcycle whilst the motorcycle was held vertical and the equipment calibrated. Once the calibration of the DAQ was completed the rider was then required to ride in a figure of eight for two complete circuits to calibrate the global positioning sensor (GPS).

The test required individual riders to achieve an approach speed of 30mph and to maintain this speed throughout the entire manoeuvre i.e. from entering the approach straight to bringing the motorcycle to a stop at the end of the exit straight. The requirement for a successful run was that the target speed should

be achieved and maintained throughout the course and that no cones were struck during the run. Each rider was allowed five runs and those runs which reached the required criteria were stored following downloading of the data.

5.5 Instrumentation

The data acquisition system (DAQ) was the RT3000 inertial and global positioning system (GPS) Measurement system manufactured by Oxford technical solutions and kindly loaned by Datron Technology of Milton Keynes. The RT3000 is a data acquisition system combining Global Navigation Satellite System (GNSS) receivers and an inertial measurement unit. It is equipped with three 10g Servo accelerometers and three 100°s microelectromechanical (MEMS) gyros. The measurement unit has signal conditioning applied to the accelerometers and the angular rate sensors. The integrated outputs give $\Delta\theta$ (change in angle) and Δv (change in velocity), rather than acceleration and angular rates. This system measures position, velocity, acceleration orientation, angular rates, angular accelerations and slip angle. The unit samples at 100Hz and the measurements are aligned to GPS time. The technical specification of the RT3000 is at Appendix 8. Initially the instrumentation selected and fitted to the motorcycle was limited to accelerometers in the x, y and z axis. These were supplemented by a 2D S_Map magnetic steering angular position sensor ($\pm 40^\circ$) mounted on the motorcycle's top steering yolk.

The RT3000 system mounted on the motorcycle was fitted with a global information system (GIS) tracking system capable of recording the course taken by the rider during each of the test runs. It was expected that this tracking system would also be sufficient to determine the speed of the machine at any point chosen during the run. The setup calibration prior to testing was difficult, requiring the steering sensor to be centralised and the height of the DAQ above ground level to be determined. To set the steering sensor required that the

steering was set as close as possible to zero i.e. the front wheel pointing directly ahead and in line with the motorcycle. Once this initial orientation was achieved and entered, the steering was then turned fully to stop in each direction to set the maximum possible turning angle. To determine the height of the DAQ the motorcycle had to be perfectly upright with the steering set to zero. If at any time the system was turned off or there was a delay between test runs, the entire setup procedure had to be repeated.

The height of the system was the height when the suspension was compressed by a rider's weight. As previously stated this required that the rider sit on and balance while the machine was held vertical so that the measurement could be obtained and entered. Additionally the location of a reference marker on the DAQ in relation to the centre of the motorcycle needed to be entered, fortunately this was a measurement that could be obtained during the installation of the DAQ on the machine and did not change during a test day (unless the system was removed and then reinstalled), but it had to be entered as part of the set up procedure. Before a test could be run and to finalise the calibration procedure the rider had to complete two complete circuits of a figure of eight manoeuvre at slow speed, this was a requirement in order to orientate and set the GPS tracking system.

Unfortunately it was impossible to see any of the collected data in order to determine if a run was 'successful'. To examine the data the system needed to be downloaded and the data stored into memory on a laptop before any interrogation of the data could be undertaken, thus although the system allowed for multiple runs only one test run could be completed at a time in case of system failure or poor riding. Due to time constraints and rider availability this

proved to be very problematic in that it was impossible to know if the system was working correctly or not.

5.6 Observations

It was observed that the volunteer riders were initially very keen to contribute to the research but clearly considered the time taken to calibrate the DAQ to be an inconvenience. This may have had an adverse effect on the way in which they rode the course as they were conscious of the time taken out of their day to do the test. The observation was that riders were attempting to rush and get away. If this observation was correct (and the author strongly believes it was) any data collected might not be a true representation of the rider and therefore invalid for the purpose of this research.

It was therefore evident from the first test day conducted at a police 'Bike Safe' meeting held at the Haynes Motor Museum in Wiltshire that although the arrangement and instrumentation did work, it was limited and failed to identify any particular differences between the ability of the riders tested i.e. to determine how experience and training affected the ability of riders to instigate a 'swerve to avoid manoeuvre'. In addition the GIS system was not as accurate as had been hoped and it was impossible to determine a speed for the motorcycle at any given point on the course. The speed at which the orientation was carried out also proved to be problematic as if the rider executed the manoeuvre quickly the resultant position plot and course could be a considerable distance from the test location, again invalidating the data set.

5.7 Review of the initial instrumentation and test manoeuvre

A review on the evening of the initial 'Haynes' test day was imperative as a number of critical issues were identified during the first day which unfortunately caused the second day to be cancelled. These issues were:-

- the course itself, did the design meet the research criteria?

- rider selection?
- did the riders anticipate the 'event'?
- time taken to calibrate/set-up the instrumentation!
- how does a rider initiate the turn?
- did the instrumentation capture the correct data / what forces needed to be monitored?

5.8 The revised test course

The initial serpentine course, although simple in design is not easy to ride at a constant 30mph (13.41ms^{-1}) due to the compact size of the course and especially when riding an unfamiliar motorcycle. It was noted at 'Haynes' that the more experienced riders, although they complained about the age of the test machine, were more adept at executing the manoeuvre than novice riders and actually relished the task (an aspect which also caused concern). The course itself did not require any sudden change of direction and if executed competently the transition from right to left became smooth and uniform. The consequence of this being that in any data capture event any steering input would be more difficult to identify and analyse. Furthermore because the course design did not require any sudden change of direction the only potential differences in riding style were that novice riders were significantly slower and unable to negotiate the course at the requisite speed and tended to 'wobble' as they were not confident in slow riding skills.

This review identified that it was necessary to design a course that tested the rider in such a way that it would identify the potential differences between different riders. Examination of the design criteria for motorcycles identified that if possible the five manoeuvres to evaluate a motorcycle's manoeuvrability should be incorporated in the new course design.

A more testing course was therefore required, one that included a sudden 'testing' manoeuvre which could easily be identified not only on the course but also within the collected data. Various layouts were considered but the course that met the criteria was the 'avoidance' manoeuvre test used within the DOT off-road test. This test is a requirement to be passed by novice riders progressing to a full UK licence. The complete DOT layout (Appendix 7) is either a swerve to the left or to the right and is selected by the examiner on the test day. This manoeuvre met the research criteria in more than one aspect: it was a rider familiar manoeuvre which all riders, novice or experienced should be able to execute. It required a sudden change of direction, a return to the original direction of travel and a requirement to bring the motorcycle to a halt within a given distance.

It is a requirement that the avoidance manoeuvre be conducted at 30mph (13.41ms^{-1}) around an offset cone within 10m. The manoeuvre is constrained by an additional cone placed some 2.7m longitudinally and 2.7m laterally from the offset cone. A slight modification was made to the DOT test in order to ensure there was no undue lateral movement of the motorcycle at the commencement of the test. To achieve this, the curved approach in the DOT test was removed and a straight approach adopted (figure 18 below).

Figure 18 The modified DOT test course



To ensure the test is carried out at the required speed a speed 'trap' is positioned immediately prior to the avoidance manoeuvre. This approach to speed detection was also adopted by this research. In order to achieve a steady

requisite speed of 30mph (13.41ms^{-1}) riders are allowed a suitable distance prior to the test area, for a detailed layout see Appendix 10.

The major advantage of this particular test is that all new riders must pass it to obtain a full motorcycle licence. This basic requirement therefore provided a suitable constant which could be taken as the basic riding ability required against which all other riders can be compared.

5.9 Rider selection

The approach taken at 'Haynes' did allow for a good cross section of the riding population but it was restricted in that it did not allow for sub groups to be developed and directly compared. The only way this could be achieved would be by multiple test days and building sub groups as rides from different abilities were tested. In the presented research it is a requirement that the riders range from novice to advanced in clearly identified parameters. In adopting this rationale it is possible to examine a particular ability group or a mixed group for direct comparison and analysis. The logical solution to this issue was to adopt the same categories as used in the first part of the research i.e. the detailed questionnaire. The categorisation of riders is therefore:

- trainee - someone who has not passed the DOT test but is ready to take the test
- novice - a rider who has passed the DOT test but has been riding on a regular basis for less than a year from test
- experienced - the experienced rider is a person who has been riding in excess of one year but who has not undertaken any additional training
- advanced - a rider who has undertaken specialist training in counter steering

- expert – a rider who has extensive experience of racing either as a professional or keen amateur

5.9.1 Anticipation by riders

This observation was first identified by a rider who asked the question “*when do you want me to turn?*” At slow speed the rear wheel of a single track vehicle does not follow the front, however as speed increases the rear wheel follows a track closer and closer to the front. At the same time the lean angle also increases allowing the rider to negotiate the curve more smoothly. If riders were anticipating the turn and trying to initiate the turn early there would have to be a second steering input to stop the roll (lean) of the machine otherwise capsizing would eventually result and the delineated course would not be followed. This second steering input would show in the collected data but may be difficult to identify, if present and unidentified the analysis may be questioned. By adopting the DOT avoidance manoeuvre the rider must achieve a prescribed speed at a given point and must initiate the swerve at a precise point otherwise the manoeuvre would not be successful. The rider may anticipate what to do but by adopting a straight approach to the manoeuvre the rider is restricted to when and where to initiate the turn, due to the tight constraints of the course any additional input would cause the rider to either strike the cone or leave the prescribed track.

5.10 Time taken to calibrate and set up the DAQ

The RT3000 Inertial and global positioning system (GPS) Measurement system manufactured by Oxford technical solutions was without doubt an excellent DAQ and had the capacity to take additional sensors if required. There were three major concerns with the equipment:

- time to set up and calibrate
- accuracy of the GPS

- ease of accessing the data

The equipment was only on loan and therefore for prolonged testing additional expenses would by necessity be incurred. Researching other DAQ systems identified the Vericom VC4000 DAQ as a potential replacement. Enquiries with the manufacturer confirmed that the VC4000 DAQ also was capable of GPS tracking and would therefore be a suitable unit. The VC4000 once set up to accept various sensors only required two key strokes to 'zero set' (with the rider sat on and controlling the motorcycle) prior to each test run a considerable saving of time and inconvenience to the rider. The data was easily accessible at the end of each run without the need to download and the internal memory of the unit would allow for approximately 20 test runs using 12 external sensors with a collection rate of 100Hz. The decision to purchase the Vericom VC4000 DAQ was made.

5.11 How does a rider initiate the turn?

The crucial aspect of the research had not been identified. The magnetic angle position sensor was fixed to the top steering yolk and monitored the amount of steering being applied by riders. The accuracy of the sensor was not questioned but the sensitivity was. The sensor range was $\pm 40^\circ$ producing an output in the range 0 – 5 volts. The data output did not identify any significant steering input and therefore the resolution of the sensor was too low.

5.12 Was the instrumentation capturing the correct data

The initial setup only monitored the X, Y & Z axis together with the steering angle. A more in-depth analysis of the physical properties of motorcycle steering geometry combined with a revisit of the literature review identified that the major aspects of motorcycle steering were how much steering was required in the opposite direction (countersteer) and how much force the rider required to apply to the handlebars in order to initiate the turn. The research criteria required that

all aspects of how individual riders steered the motorcycle needed to be captured. It was therefore decided to make observations of:-

- the steering angle
- the force applied to the handlebars
- the rate at which the steering was applied
- the roll rate of the machine during the turn and hence the lean angle

In addition the VC4000 would also log acceleration in the X, Y & Z axis together with the yaw rate of the unit.

5.13 Instrumentation review

The starting point for the revision was the original serpentine test course track (figure 17). Analysis showed that the initial setup procedure was not satisfactory and the data failed to show any initial countersteering angle even though there were two changes in direction. The Oxford DAQ systems calculated roll, pitch and yaw from the three internal accelerometers. Unfortunately the speed of the motorcycle could not be satisfactorily determined at any particular location on the test course and the GPS proved too inaccurate. The initial instrumentation did not have the ability to determine how much force a rider exerted on the steering during the manoeuvre but there was the capability to determine the banking angle from the roll rate data. If as expected individual riders applied varying countersteer angles dependent on their ability, the potential that riders would also exert varying force on the steering should also exist. Although in the initial instrumentation it was recognised that the motorcycle was an articulated single track vehicle, little consideration had been given to how much force would be required to counter the combined righting properties of trail and gyroscopic effects within the motorcycle's system.

The revised test course required that the rider would be required to exert sudden steering inputs, therefore any sudden changes in steering angle, the forces applied to the steering and steering rates should be identified. Additionally it was identified that the speed of the motorcycle at a given point should be identifiable within the captured data.

5.14 The revised Instrumentation

The new instrumentation package consisted of two distinct parts, those sensors mounted on the steering system and those mounted with the data acquisition system on the main frame of the machine.

5.14.1 The steering system

The steering system consisted of a steering angle sensor, steering rate sensor and the steering torque transducer. The data acquisition system a Vericom VC4000 DAQ together with an additional rate gyro sensor mounted on the centre line of the motorcycle provided tri-axial accelerometers, roll and yaw rate.

To determine the force applied to the steering by the rider, required a torque transducer to be fitted between the handlebars and the top yoke of the motorcycle's headstock. To ensure that a sensor accurately monitored the torque being applied to the steering it is essential that the torque sensor is mounted perfectly in line with the head stock axis.

The motorcycle's handlebar assembly and upper yolk have been replaced in order that a torque transducer can be mounted in line with the steering axis and that the handle bars are exactly the same ergonomically as the originals i.e. the rider's hand positions remain the same both laterally and vertically, thus ensuring that the rider assumes the same pose as the designers of the motorcycle intended and that the ergonomics of the steering should are not compromised by the fitment. To achieve these requirements it has been necessary to manufacture two new top yokes, one designed to replace the

original to accommodate the mounting of the torque transducer and one onto which the original handlebars can be mounted at the correct angles and height and fixed onto the upper face of the transducer.

The criteria for the torque transducer required that it should be strong enough not to be damaged by excessive force during transit and movement of the motorcycle yet sensitive enough to monitor the forces being applied during the avoidance manoeuvre. It was decided to use a more substantial unit that was theoretically required. Research shows that a force of approximately 40Nm is applied during a lane change exercise (Varat et al., 2004). Procter & Chester (Measurements) Limited of Kenilworth, England supplied a TRX static torque transducer rated at 100Nm with an accuracy of $\pm 0.06\%$ of the rated output. This unit has a safe overload of 120% of its rated capacity and an ultimate overload of 300% of its rated capacity. The transducer required an inline amplifier and both units were calibrated at manufacture in both the clockwise and counter clockwise directions, thus when riding in a straight line on a level pavement the torque should be zero. The output required by the Vericom VC4000 DAQ is 0 - 5 volts hence the transducer and amplifier were calibrated at -100Nm (counter clockwise) and 100Nm (clockwise), the output being 0.066 volts and 4.938 volts respectively. The full technical specification and calibration certificates for the torque transducer are at (Appendix 11).

Figure 19 below shows the TRX torque transducer mounted on the Kawasaki GT550 test motorcycle between the two new top yolks.

Figure 19 Steering torque transducer



The steering angle sensor was initially determined through the use of a $2D \pm 40^\circ$ magnetic angle position sensor mounted on top of the motorcycles original top yolk. Due to the re-engineered handlebar mounting to accommodate the new torque transducer, the magnetic angle position sensor was relocated and fixed to the underside of the lower steering yolk see figure 20. Again to ensure accurate monitoring of the steering angle the device must be mounted on the centre line of the steering axis. The old sensor was replaced with another 2D magnetic sensor with an output range of $\pm 20^\circ$ (SA-MAP20-000) thus reducing the monitored range by half but increasing the sensitivity of the unit. With a limited range of only 20° in either direction it is crucial that the sensor is mounted with the front wheel in neutral steer and the sensor output is 2.5 volts, due to the sensitivity any offset may result in lost data. The sensor has a output voltage of 0 – 5 volts, full technical specification of this unit is at Appendix 12

Figure 20 Steering angle sensor

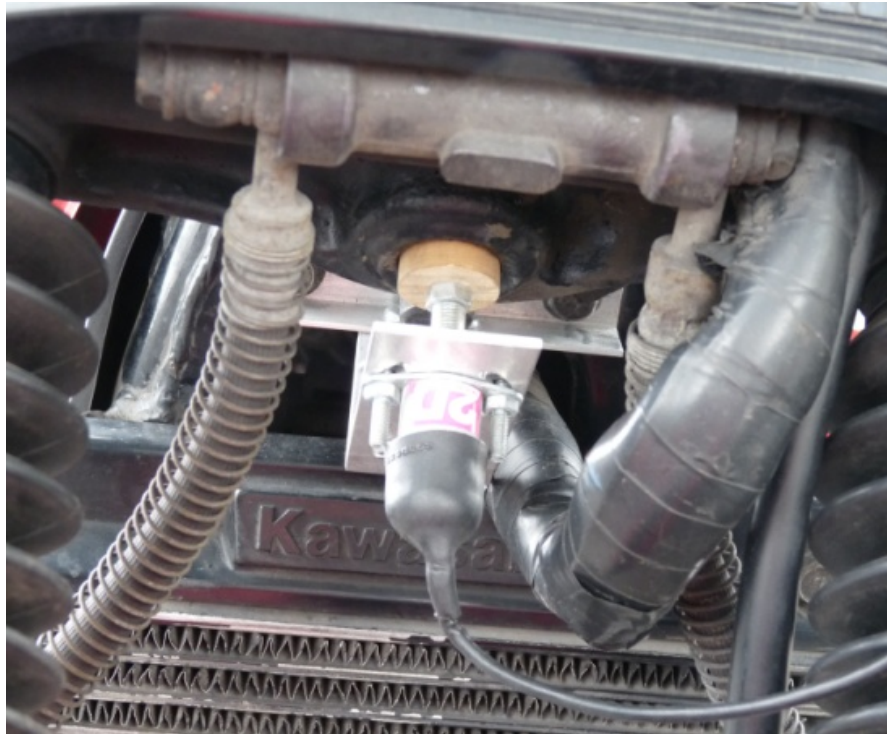

To monitor the steering rate a Horizon HZ1-90-100A MEMS angular rate sensor is mounted inline on the steering axis above the torque cell figure 21. The Horizon sensor has a range of $\pm 90^\circ$ with a full scale output of 0.5 – 4.5 volts, full specifications are at Appendix 13. The calibration of this sensor when connected to the VC4000 DAQ is automatically zero set when the VC4000 is zero set.

Figure 21 Steering rate sensor mounted above the torque transducer



5.14.2 The Main Frame and DAQ

As stated earlier the decision was taken to replace the Oxford technical RT3000 DAQ system with the Vericom Computers VC4000 DAQ. The obvious advantages of the VC4000 are that it is much quicker to set up prior to each run. Advantageously for the set up procedure the unit has two spirit levels for vehicle mounting of the unit when summation is not being used. The horizontal level which is clearly visible from the operator's position at the rear of the motorcycle is invaluable in directing the rider which way the machine needs to lean to centralise the machine prior to calibration.

The new unit provides acceleration in the X, Y & Z axis using MEMS units together with the yaw rate which is taken from a $\pm 150^\circ/\text{Sec}$ angular rate gyro. The 3D accelerometers have a range of ± 2 or $\pm 6\text{G}$, shock survival 10,000G an accuracy of $\pm 0.0030\text{G}$ and bandwidth/sample rate of 1 – 1000Hz. Additional Analog sensor input have a range of 0 – 5VDC, a resolution of 16 bits and a

sample rate of 1 – 1000Hz. The unit having been developed for use within collision investigation also accepts tachometer information in the range 0 – 15,000 RPM. Although the unit has an internal power supply it was decided to power the unit from the motorcycle battery to avoid the unit from powering down due to low battery power. Full technical specification is at Appendix 14.

The VC4000 is supplied with its own software Profile 5 which allows for easy calibration of any additional analog sensors dependent on their output range e.g. the calibrated range for the TRX torque transducer are 0.066v – 4-938v for 100Nm – 0 – 100Nm clockwise and counter clockwise forces using the Profile 5 software which is provided with the DAQ. Profile 5 can then be used to export the collected data to a comma separated values file (.csv) format.

Figure 22 Vericom VC4000DAQ mounted on the rear of the test motorcycle



The VC4000 is extremely light and compact allowing it to be easily mounted onto a platform together with other sensors and terminations for subsequent mounting at the rear of the motorcycle (figure 22).

Also mounted at the rear of the motorcycle and collocated with the DAQ was another Horizon HZ1-90-100A MEMS angular rate sensor. This angular rate sensor was mounted longitudinally to the centre line of the motorcycle at seat height to monitor the roll rates of the machine during the swerve/avoidance exercise. Subsequently the lean angle of the motorcycle could be calculated.

5.15 Discussion

The test day at Haynes proved to be a crucial day in this research. Having identified the above issues it was necessary to redefine the test procedures and the research objectives before any additional tests could be carried out. Crucially these objectives had to be achieved and it was therefore necessary to totally review the research criteria, the overall objectives and how these objectives were to be achieved. The review required a more critical analysis of how motorcycles are designed and what rider inputs are required in order to initiate a turn, this in turn required a complete remodel of the test course and a completely new instrumentation and data acquisition regime.

The new course and instrumentation package was evaluated at Little Rissington Airfield in Gloucestershire GL54 2LR using a level surface which allowed for extensive testing of the motorcycle, the new test course and the instrumentation package. Consideration was given to using the VC4000's calculation of speed through the course but due to the overall length of the course together with an approach area would necessitate an additional assistant to carry out the initial instrumentation calibration at the start of the run. If the calibration was carried out adjacent to the test course and the rider rode away, then turned through

180° before accelerating and riding the course the accelerometers would be subjected to accumulated drift and the subsequently calculated speed or distance would be inaccurate. It was therefore essential that a timing gate be positioned similar to the new DOT off-road test.

A second evaluation day was arranged at Little Rissington where a pair of Brower timing system gates was positioned to monitor the last 5 metres of the course prior to the swerve manoeuvre. The Brower units are accurate to 1/1000 of a second with a radio switch accuracy of 0.0005 of a second. This equipment provided the mean speed over the last section (5m) of the course and gave a reliable indication of the motorcycle speed as the rider negotiated the offset cone of the avoidance test.

Later examination of the evaluation data identified that due to the extended data collection time i.e. from DAQ calibration, riding away and returning to execute the test, it was extremely difficult to identify the exact position within the data where the event (swerve around the cone) took place. The solution was to include an Infra-Red (IR) beam across the track alongside the last timing gate and transmit the make/break by an RF signal to the DAQ which in turn attached a tag to the data as the machine passed the last gate. The receiving unit was mounted onto the motorcycle adjacent to the DAQ and was powered from the motorcycle's 12 volt battery. It is appreciated that there will be a slight time delay in the signal being received by the DAQ and therefore the 'tag' does not categorically identify the exact point where the motorcycle 'broke' the IR beam.

5.16 Conclusion

In order to ensure repeatability of tests for analytical comparison, it is essential that any test can be repeated with little or no change to the original. It was recognised that the data collection/rider evaluation could not be achieved easily and would have to be done over a number of months. Initially the intention was to make a number of visits to police 'Bike Safe' events. Clearly following the 'Haynes' experience this was not going to be suitable and therefore a suitable long term venue needed to be identified and secured.

Sean Hayes of 'Circuit Based Training' (a motorcycle training company) located at the Mallory Park Racing Circuit, Leicestershire offered his assistance. As a consequence all testing and data collection has been done at the Mallory Circuit. The most obvious location for the test area was at the end of the Stebbe Straight between Gerard's and Edwina's this being a level pavement with no apparent cross fall and has an excellent texture depth.

Figure 23 Mallory Park Circuit



This area not only provided an area of sufficient size where the test course could be laid but an area where the test riders could be easily controlled.

Evaluation of data following the first test day at Mallory revealed a number of inconsistencies, especially in the Gx axis where it appeared -ve acceleration of some description was taking place. This inconsistency was initially only

identified within the novice rider's data but later appeared in a number of data sets. The potential for a rider to either disengage the clutch or momentarily apply a brake is consistent with a rider perceiving that they are approaching the manoeuvre at what they may consider to be an excessive speed when in reality it is not. Additional sensors were therefore fitted to the test motorcycle to monitor engine speed (tachometer), engagement of the clutch, front and rear brakes. These additional sensors were essential in evaluating each individual test run data set to ensure that they met the 'test criteria' prior to detailed analysis. A detailed list of sensors, calibration and fitment is found at Appendix 15.

Chapter 6 Results

6.1 Introduction

During the course of this research a total of 204 tests were conducted. The experience of each rider was recorded in relation to how long the individual had been riding. Once the tests were completed the results were placed into the respective groups and can be broken down as follows.

Table 4 Number of tests conducted in each rider group

Rider Category	Novice	DOT	Experienced	Advanced	Expert
Number of Tests	68	19	75	27	15

The construction of the test course and the individuality of each rider made it impossible to ensure that each rider executed the test at exactly 30mph (13.41ms^{-1}) and that they maintained the initial speed throughout the manoeuvre. To make direct comparisons between the tests it has been necessary to select tests that were within certain parameters, these parameters were set at $30\pm 1\text{mph}$ ($13\text{--}14\text{ms}^{-1}$) for the transitional speed through the gate immediately prior to the swerve and that the execution of the test would constitute a 'pass' for the purpose of the DOT test. In order to qualify as a pass the rider must negotiate the test at 30mph (speed checked but if not exactly 30mph the examiner does have discretion), there must be no contact between the motorcycle and any of the cones and the machine must be brought to a complete stop between the two cones at the end of the course.

The aim of this research was to identify any similarities or differences in the way individuals steer motorcycles which could assist in rider training to reduce the

number of riders injured in 'swerve to avoid' scenarios. As identified within the 'Experimental Design' five categories of rider have been identified for analysis and comparison. Not all the riders within the novice group, who performed 68 of the total tests, would have been successful if they were undergoing the DOT off road evasion test. For the purpose of the research it is essential that the rider must be capable of passing the DOT test, hence two of the groups, the novice and the DOT group have been combined for the purpose of analysis and comparison. Application of the above parameters identified at least 10 tests in each group, 40 tests in total that were suitable for comparison.

The initiation of steering as previously identified must consist of steering opposite to the desired direction (countersteering) in order to successfully negotiate a turn. In order to identify any difference between riders the following components have been examined:-

- the force applied to the handlebars in order to initiate the initial steering
- the magnitude of the initial steering
- the lean angle of the motorcycle during the manoeuvre
- the yaw angle of the motorcycle during the manoeuvre

In order to execute this manoeuvre the rider must initiate the turn by applying an anticlockwise torque to the steering to steer in the opposite direction to the intended course. This torque increases from zero until it reaches its maximum in this direction at T1, the point where the countersteer ends. The torque then diminishes to T2 before reversing to a clockwise torque as the rider follows the motorcycle into the swerve to the right. The clockwise torque reaches a maximum at T3 and then decreases as the rider returns the motorcycle to the

original line of travel. Figure 24 is an annotated graph of the sequence by a novice rider.

Figure 24 Torque input by a novice rider

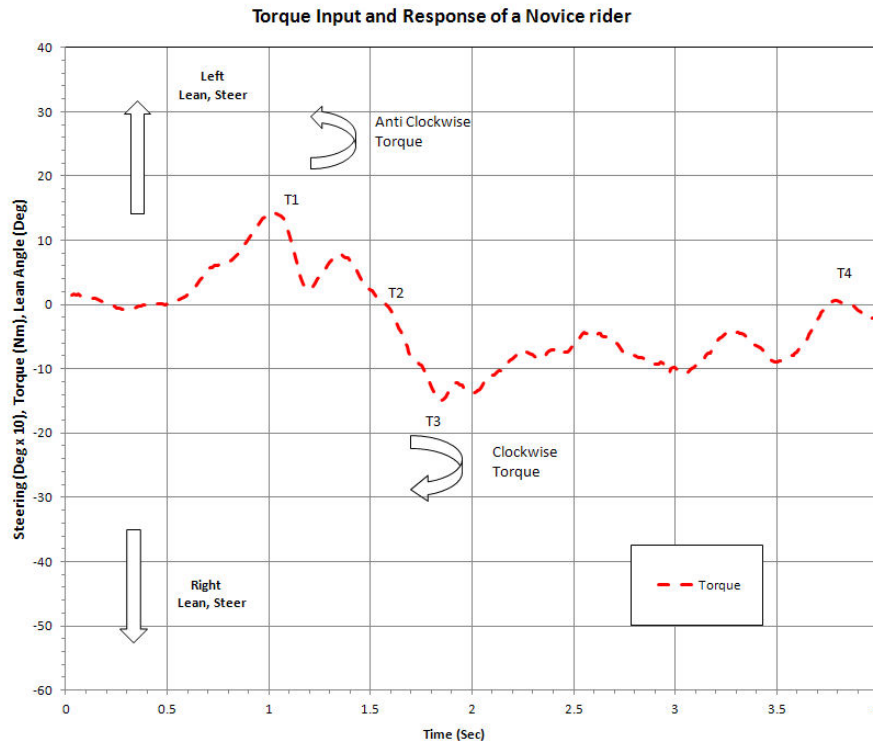

The initial application of torque by the rider to the steering enables the countersteer. The steering angle is magnified by a factor of ten to allow visualisation of the very small steering which is being applied. The manoeuvre is a swerve to the right; therefore the rider starts with a left steering angle reaching a maximum at S1, the maximum countersteer angle, before returning to the neutral position at S2. The magnitude of this initial steer angle is small and in some cases can be significantly less than 1 degree. From S2 the maximum steer angle in the desired direction of travel is achieved at S3 before returning to neutral at S4. During the recovery phase i.e. once riders have reached S4, the neutral steer position after the swerve, they must then apply steering to the left to recover and realign the motorcycle, it is anticipated that some riders may find it necessary to make some final adjustments to end in line with the end cones.

The magnitude or necessity of any final adjustment will be determined by how quickly the recovery steering is applied and the magnitude of that steering input adjusts the steering input to complete the alignment with the test course and the final stopping position at the end cones. Figure 25 is an annotated graph of the typical steering input applied by a novice rider.

Figure 25 Steering input by a novice rider

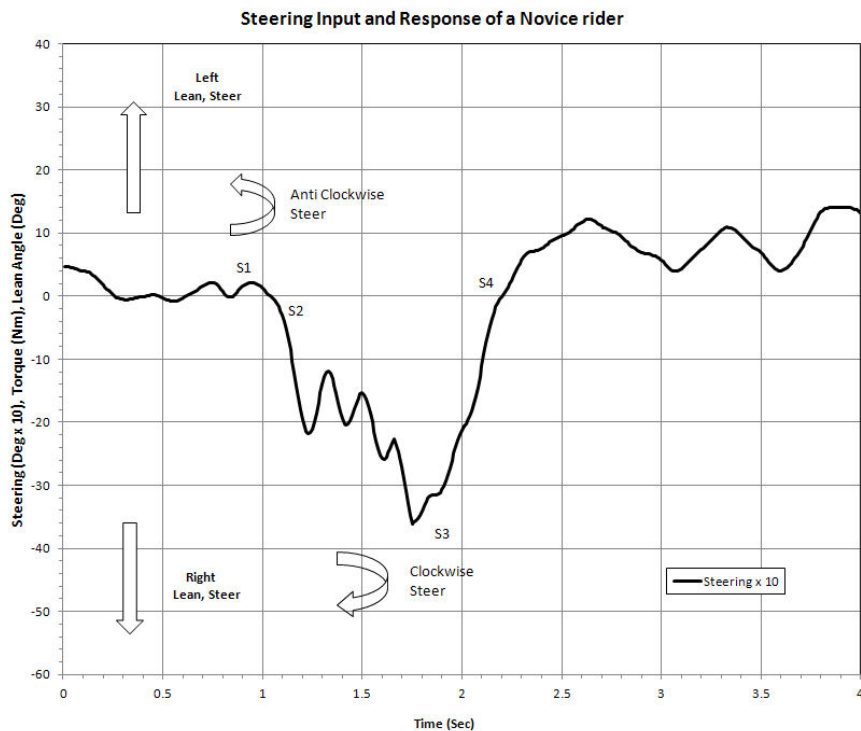

The lean angle has been calculated by integrating the output from the angular roll rate sensor fitted to the rear of the motorcycle. Therefore this angle is only the angle of the motorcycle during the manoeuvre and is measured from the vertical. It is appreciated however that in riding scenarios the rider and motorcycle do not achieve the same lean angle. Considering the riders who make up this group and the speed at which the manoeuvre is executed it is anticipated that there will be very little if any difference between the lean angle of the motorcycle and the lean angle of the rider. Figure 26 is an annotated graph of the lean angle achieved by a novice rider.

The lean of the motorcycle to the right smoothly increases along L1, to a maximum at L2, a point close to the obstacle cone. The motorcycle continues to lean right before returning to a nominally upright (neutral) position at L3 as the motorcycle then leans to the left before the reaching L4 as the rider recovers the motorcycle from the initial swerve. At L4 the motorcycle is at maximum lean to the left as the rider steers the motorcycle onto its original line of travel through the course.

Figure 26 Lean angle input by a novice rider

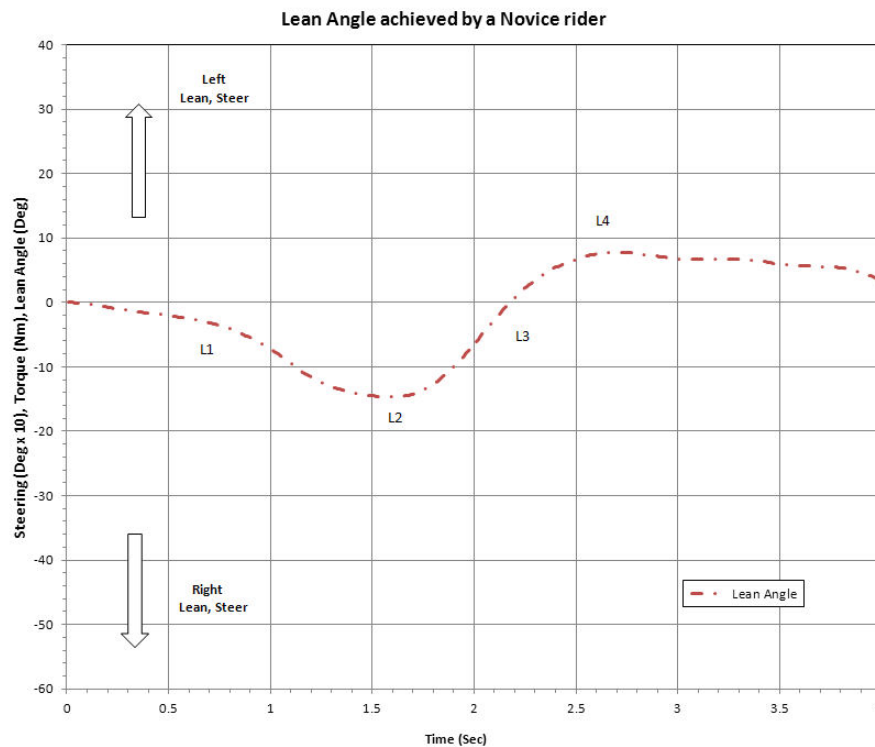

The yaw angle determined by integration of the output from the DAQ's internal gyro identifies the direction that the motorcycle is pointing during the transition through the manoeuvre. Therefore to pass the obstacle cone it will point to the right i.e. showing a clockwise rotation (-ve value). If there has been sufficient countersteer input it would be reasonable to expect that there may be some positive counter clockwise yaw at the start of the trace Y1. Figure 27 is again an annotated graph showing the four stages of yaw. Peak yaw in avoiding the cone

is reached at Y2 when the rider now recovers the motorcycle steering left (counterclockwise yaw) and passing through the neutral position at Y3. The yaw remains counterclockwise until Y4 when the rotation is reversed until such time as the motorcycle is back on its original direction of travel.

Figure 27 Yaw angle input by a novice rider

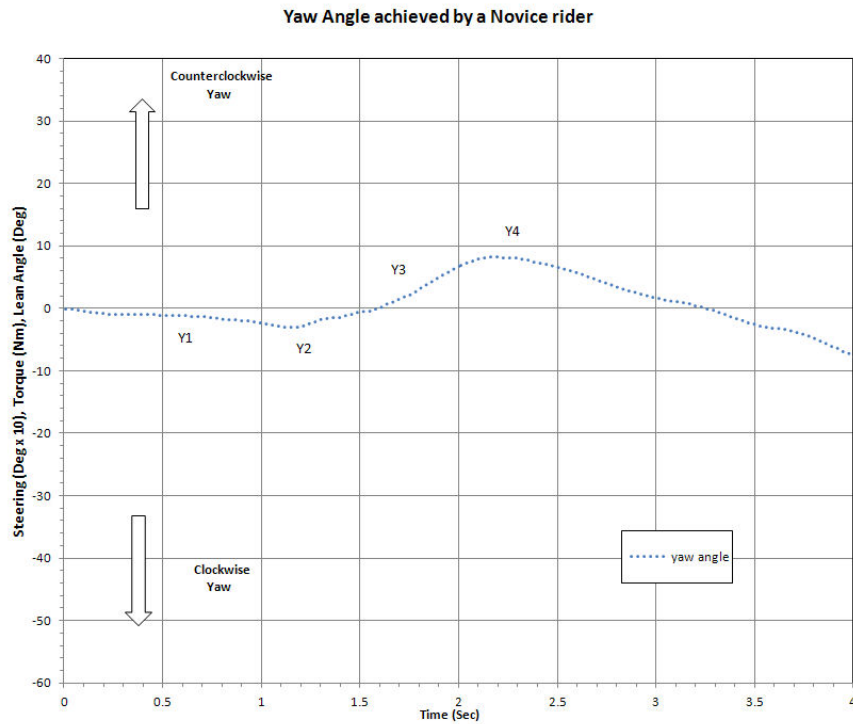

6.2 Group 1 The Novice / DOT Riders

Figure 28 gives a visual representation of the manoeuvre being undertaken from a head-on viewpoint.

Figure 28 Visual representation novice rider

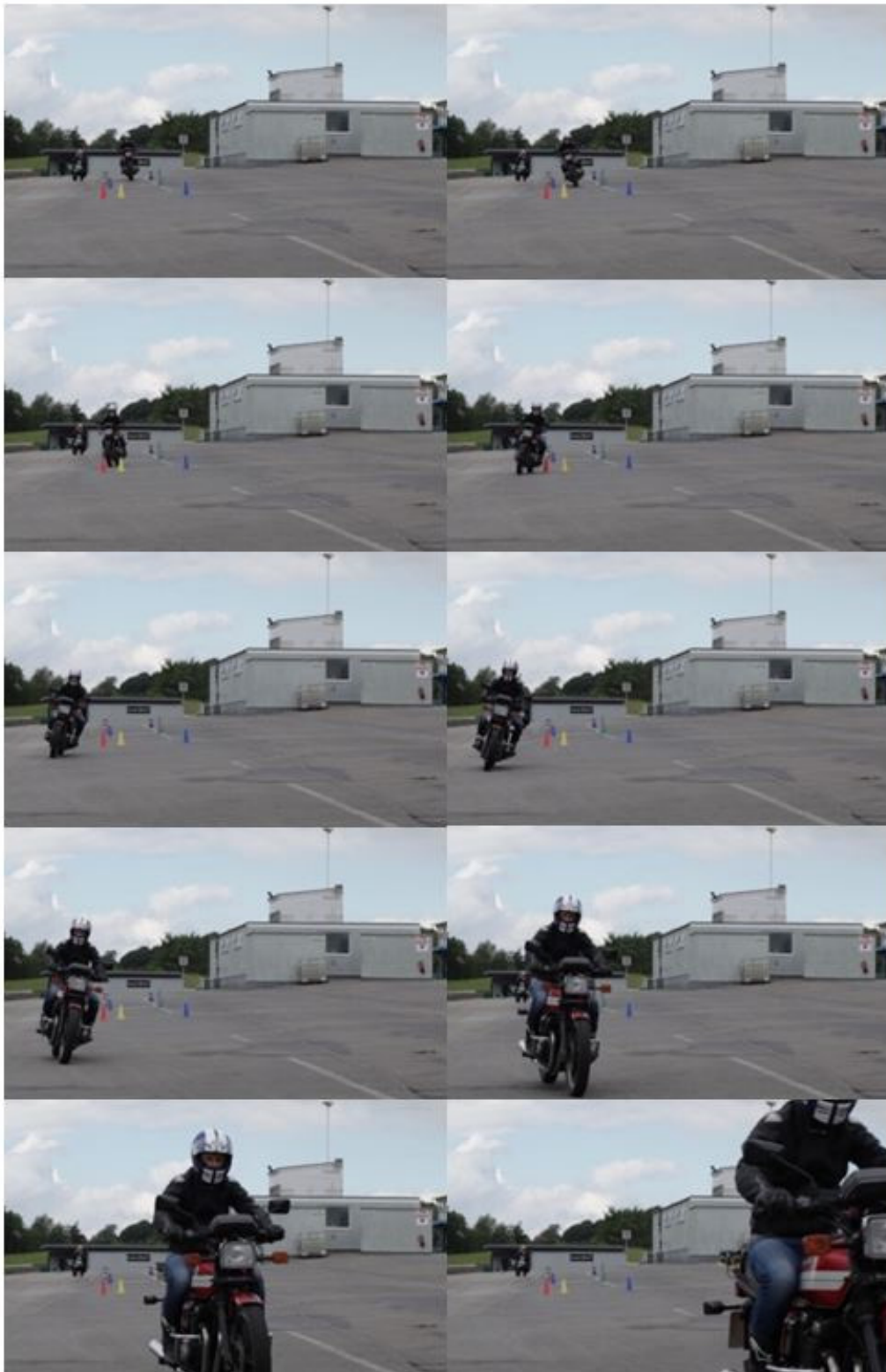

The rider is performing the 'right swerve' and recovery as per Figure 29 which gives a 'birds-eyes' view of the manoeuvre being examined.

Figure 29 Plan view of the manoeuvre



Ten tests from this group have been selected for analysis, each of which were either conducted by a novice rider or a qualified rider with a full motorcycle licence, who successfully negotiated the swerve test and would have been successful if being examined for the DOT test.

6.2.1 Torque

Phase 1 The initiation of the swerve

To visually identify any potential differences between the riders in this group and all the other groups all the data has been calibrated to the pulse from the gate sensor (1.94 seconds). This has enabled all the data to be graphed about a known impulse as the motorcycle's front wheel passes between the last cones immediately prior to the swerve. Figure 30 is an overlaid plot of the torque applied by all ten riders in this, the novice group together with the gate impulse at 1.94 seconds. The point at which individual riders start to steer can be identified by the initial application of steering torque.

Figure 30 Torque plot of the novice group

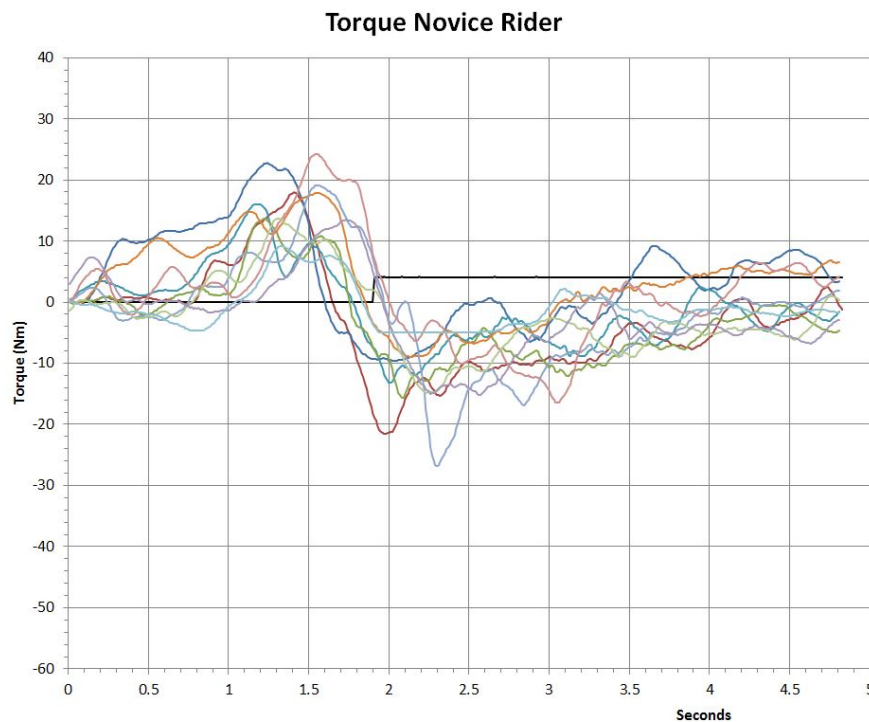

It is the initial application of torque, ‘the countersteer’, where there are identifiable differences in the way riders apply this steering. The shape of the traces from zero to T1 tends to remain at zero or close to zero before rising to T1, it is the gradient and ‘noise’ associated with these traces where the significant differences can be seen. Some of the riders apply a progressive force to the steering over a longer period and only reach a moderate maximum at T1, others apply the force more quickly over a shorter period and often this force is of a much greater magnitude. The result being that the initial countersteer and initiation of the turn is achieved much sooner by those riders who apply a larger force more quickly. The range of forces observed being applied in this research at T1 where the maximum countersteering force ends is between 9.11Nm and 24.24Nm with a mean of 16.78Nm. This is achieved between 1.21 and 1.79 seconds (figure 30), i.e. between 0.15 and 0.73 seconds before passing through the gate. The time taken to reach maximum countersteer at T1 in order to initiate

the turn is between 0.3 seconds to 1.49 seconds from the first application of positive torque and the mean time is 0.84 seconds.

There appears to be a large variation in the data set, however considering the number of individuals taking part and the initial speed parameter of ± 1 mph this is not surprising. Considering the sample data of the time interval from the initiation of the steering torque to reaching the 'gate' (Table 7 column 2) a five-figure summary lists (0.15, 0.34, 0.53, 0.66, 0.73)

- the sample minimum, $x_{(1)} = 0.15$
- the lower quartile, $q_L = 0.34$
- the sample median, $m = 0.53$
- the upper quartile, $q_U = 0.66$
- the sample maximum, $x_{(n)} = 0.73$

If the i.q.r (interquartile range) of 0.32 is applied to the lower and upper quartiles there are no outliers and the data set is only slightly skewed about the mean $\bar{x} = 0.49$. Additionally the standard deviation of this data $\sigma = 0.19$, therefore the mean ± 2 SD is 0.11 to 0.86 indicating that all of this particular group fall within the 95th percentile.

Applying the same strategy to the time taken to initiate the countersteer and to reach the maximum torque at T1 (Table 7 column 3) a five-figure summary is

(0.3, 0.59, 0.75, 1.11, 1.49)

The i.q.r is 0.52 and when applied to the lower and upper quartiles there are no outliers but the data is slightly skewed about the mean. The standard deviation $\sigma = 0.36$, therefore the mean $\bar{x} = 0.84 \pm 2$ SD includes all the data set confirming that this particular group again falls within the 95th percentile.

Finally the torque applied at T1 (Table 7 column 4) is subjected to the same rigour, the five-figure summary is

(9.11, 13.63, 16.97, 20.01, 24.24)

The i.q.r. is 6.38 with a standard deviation $\sigma = 4.6$ and a mean $\bar{x} = 16.79$. When the i.q.r. is applied there are no outliers and the data is centred about the mean. Again in this case all the data is within the mean ± 2 SD.

The graphed data appear to fall into two distinct categories, those riders who applied the initial torque quickly and those who did not. Riders 2, 5, 7 & 9 appear to be in the first category where the torque is applied quickly. The following graph, figure 31 shows this sub group.

Figure 31 Torque plot for novice riders 2, 5, 7 & 9

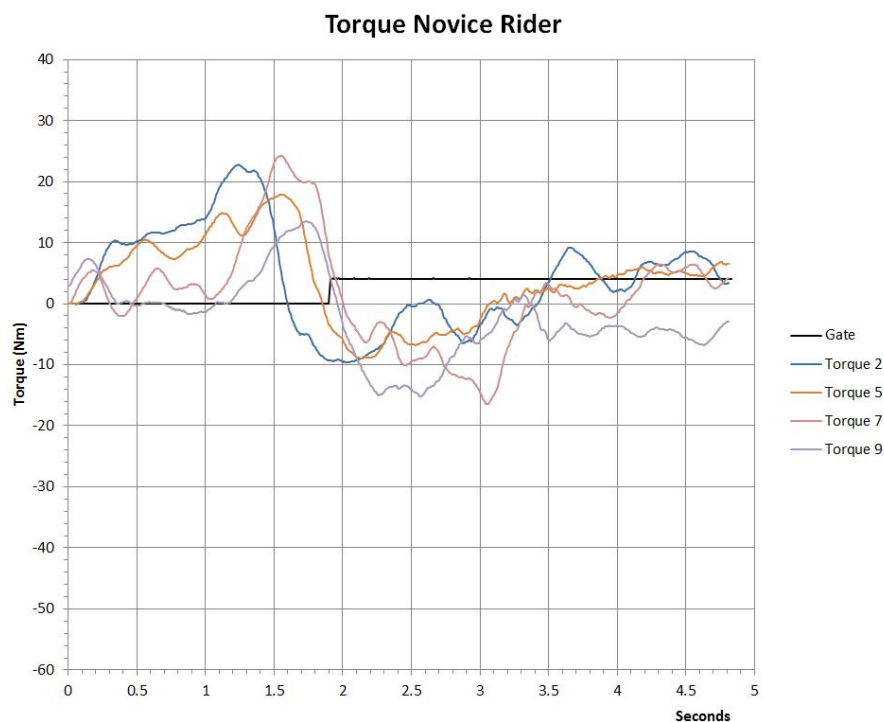

It is riders 2 and 5 who quickly apply a high steering torque before slowing the application down but reaching a much higher force at T1. Rider 7 however who applies the highest force of the whole group, initially applies an anticlockwise

force and then relaxes where the force returns to near zero before applying a countersteering force of 24.24Nm in 0.52 seconds. In relation to rider 9 it can be seen that although initially the trace rises steeply it does quickly fall back and follow the pattern of the majority of the traces. With riders 2 and 5 removed from the overall plot (figure 32), the plot is relatively compact and does not identify any other potential outliers.

Figure 32 Novice group torque plot with riders 2 & 5 removed

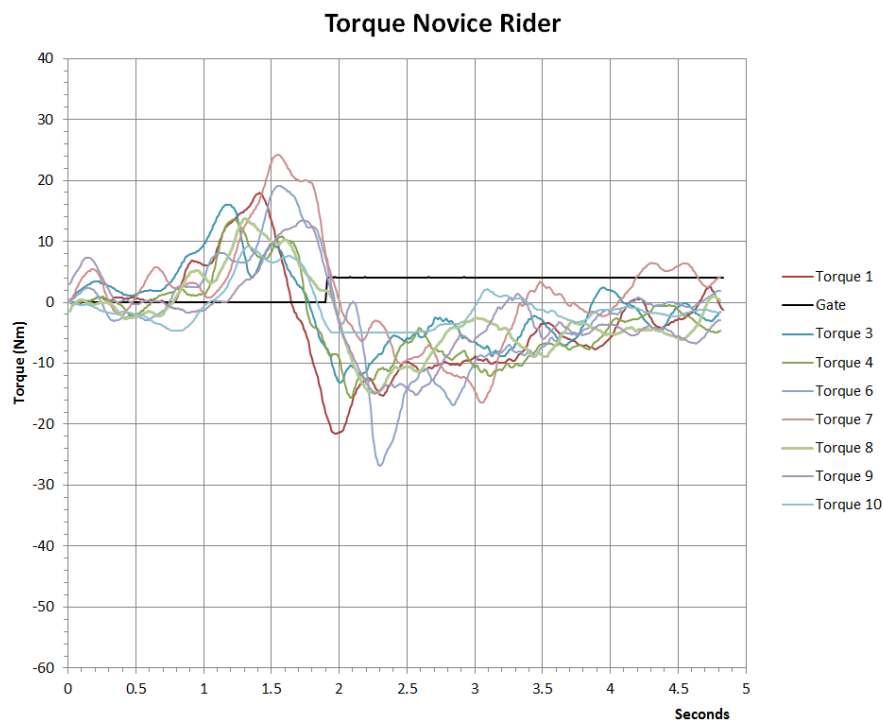

The transition from T1 the maximum clockwise torque, through T2 (zero) and to T3 the maximum anti-clockwise torque where the rider needs to apply force to the handlebars in order to steer right around the cone and following the machine into the turn are similar. Considering this transition as a single component from T1 to T3 the time taken from the commencement of the initial countersteer at zero was between 0.93 second and 2.58 seconds with a mean of 1.58 seconds. However, the intermediate time from T1 to T3 ranged from 0.56 seconds to 1.5 seconds with a mean of 0.84 seconds. The five-figure summary for this intermediate time T1 to T3 (Table 7 column 5) is

(0.56, 0.62, 0.84, 0.92, 1.5)

The i.q.r is 0.30, but when this is applied to the lower and upper quartiles it identifies that the max value $x_{(n)}$ 1.5 is a potential outlier. It does however fall within the mean ± 3 SD, the SD $\sigma = 0.27$ and the mean $\bar{x} = 0.84$.

The range of force at T3 was between 5Nm and 26.87Nm with a mean of 14.75Nm. The five-figure summary for these values (Table 7 column 6) is

(5, 9.47, 15.04, 17.78, 26.87)

The standard deviation $\sigma = 6.3$ and the mean $\bar{x} = 14.75$ identify that the data set does fit within the mean ± 2 SD but the data is skewed about the median.

Phase 2 The torque forces during the transition and recovery

The graphs all show two clearly defined peaks, both after the gate. The rider must initiate the turn by applying a force in one direction and once the turn is initiated apply a force in the opposite direction to accomplish the degree of steering the situation demands. In this particular manoeuvre the rider has to swerve to the right around the avoidance cone, once at the cone the rider must then steer back i.e. to the left, in order to place the motorcycle back onto its original course. It is therefore expected that there will be a positive anti-clockwise force identified on the graphs. None of the graphs within this category of novice riders show any clearly defined torque in the anti-clockwise direction other than the initial force required to initiate the turn.

A possible explanation for this is that the riders did not believe it necessary to swerve back because the test course allows 31 metres, from the cone to be avoided to the final stopping position. To accomplish the transition from the right steer the rider is not therefore subjected to as much pressure as in the early stages of the manoeuvre. It was not surprising therefore that the tail of the

torque traces varied according to how quickly and forcefully the riders apply the steering back to the left. The ability of the rider to recover the motorcycle from T3 to T4 and the force applied may be considered to be an indicator as to how quickly the rider may be able to return to the correct side of the road having swerved to avoid a nearside incident.

6.2.2 Steering angle

Phase 1 The initiation of the swerve

To identify any possible change in the steering angle during the initial application of force to the handlebars of the motorcycle in the counter clockwise direction it is helpful to multiply the recorded data by a factor of 10. Examination of the initial countersteer from zero to S1 again showed marked differences in the way the countersteer was applied. There were differences identified within the initial torque application and it follows that similar differences should be expected within the initial steer angle. Figure 33 is a plot of all the group rider's steering applications and for comparative reasons the impulse from the gate sensor is included.

Figure 33 Steering plot of the novice group

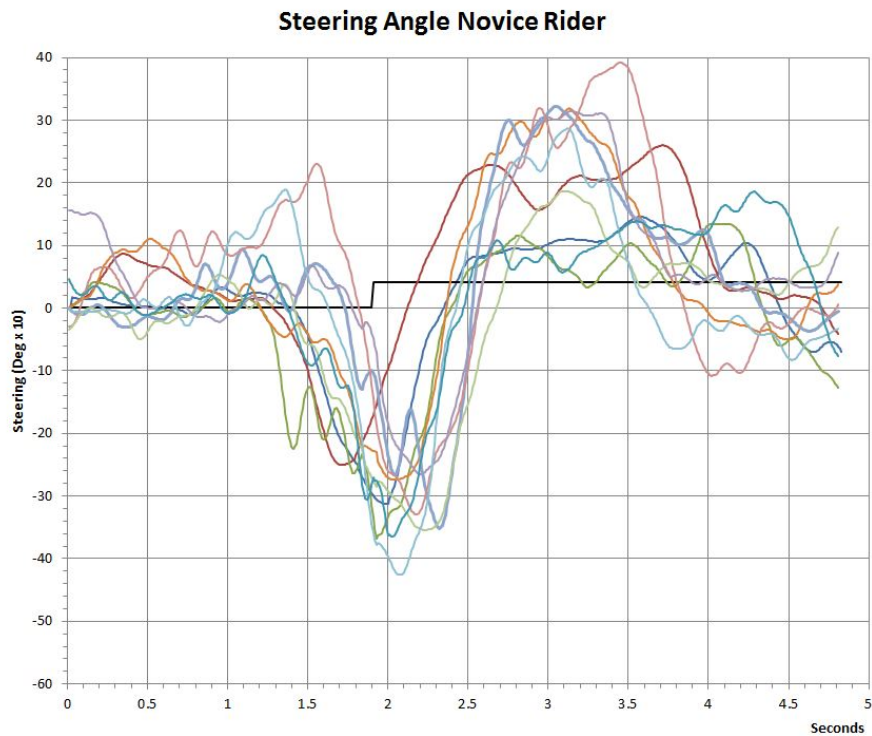

None of these traces are smooth, they all show marked changes in the steering angle before reaching a peak, indicating that the steering has been applied possibly erratically or with uncertainty. All the riders applied steering to the left (countersteering) in the initial phase of the manoeuvre and this initial steering angle reached at S1 ranged from 0.33° to a maximum of 2.3° . This is approximately a seven fold difference or a 605% difference between the two.

This difference appears to be significant, however when the data is placed in a five-figure summary, there is a potential outlier at 2.304° .

(0.327, 0.504, 0.857, 1.302, 2.304)

The i.q.r. is 0.799 and when applied to the upper and lower quartiles gives a range of -0.295 to 2.100. Taking the whole data set, the standard deviation $\sigma = 0.64$ and the mean $\bar{x} = 0.99$ identify that the data set does fit within the mean ± 2 SD. The data is however skewed about the median.

The time taken from the first application of steering torque to reach S1 ranged from 0.17 seconds to 1.09 seconds with a mean time of 0.41 seconds. These values relate to 0.99 and 1.61 seconds in figure 32. Therefore taking the novice group as a whole, S1 the maximum countersteer, was achieved 0.42 seconds prior to T1 the maximum force applied to the handlebars to initiate the countersteer. Three of the riders achieved peak countersteer at the same time as they reached peak torque, these were riders 4, 7 & 10 (figure 34), yet the times taken to reach the peak from the initiation of the steering torque were 0.61, 1.08 & 0.33 seconds respectively.

Figure 34 Steering plot for novice riders 4, 7 & 10



A statistical analysis of the time from initiation to peak countersteer at S1 reveals that rider 7 is yet again a potential outlier. The five-figure summary for the data (Table 8 column 1)

(0.17, 0.18, 0.34, 0.51, 1.10)

The i.q.r. is 0.33 and when this is applied to the lower and upper quartiles a range of -0.15 to 0.83 is identified. Clearly 1.09 is a potential outlier. Taking the whole data set, the standard deviation $\sigma = 0.28$ and the mean $\bar{x} = 0.41$ identify that the data set does fit within the mean ± 3 SD but the data is skewed about the median.

Four of the traces do not fit particularly well within the overall plot these are riders 2 and 5 together with riders 7 and 10, two of the riders who reached peak steer at the same time as peak torque. Three of the four traces, those for riders 2, 5, and 7 all initially rise to 0.65 degrees in 0.2 seconds, thereafter the traces for riders 2 and 5 diminish to S2 (neutral) after a further 1 second before moving to S3 the maximum steer angle to the right in order to swerve past the cone. Rider 7 reduced the initial steer and then reapplied the countersteer reaching 2.3 degrees, the largest countersteer angle in this group after a further 1.35 seconds. Rider 10 also achieved a large countersteer angle of 1.89 degrees however there was very little deviation from zero in the early stages and this magnitude of steer was achieved within 0.54 of a second. A countersteer angle of these magnitudes is large and was not expected to be achieved by a novice rider. Plotting these separately, figure 35 identifies the characteristics of these four traces.

Figure 35 Steering plot for novice riders 2, 5, 7 & 10



At S3 the riders achieve the maximum steering angle in order to miss the cone, the angles ranged from 2.50 to 4.26 degrees with all the data falling within the mean $\pm 1\frac{1}{2}$ SD. The percentage difference is only 70% compared to that at S1 which was 605%. The time interval between S1 and S3 should be similar to the interval between T1 and T3. A five-figure summary of the data (Table 8 column 5) reveals:-

(0.62, 0.70, 1.13, 1.4, 1.75) with an i.q.r. of 0.7

There are no outliers and the whole data set fits within the mean $\pm 2SD$, the standard deviation for this data set $\sigma = 0.39$ and the mean $\bar{x} = 1.10$.

Phase 2 The steering angles during the transition and recovery

Once S3, the maximum steering angle to avoid the cone has been reached the rider must then steer to the left in order to return to the original direction of

travel. Riders cannot relax at this stage as there is a cone to the right of the avoidance cone which must also be avoided.



Figure 29 Plan view of the manoeuvre

This cone does not pose any problems for the rider and often they did not realise it was there, the rider's concentration being on the avoidance manoeuvre and a return to the original line.

The time period from S3, the maximum steering angle to S4, the point where neutral steer is reached prior to the rider steering to the left ranged from 0.21 to 0.47 seconds, yet when taken from the start i.e. the initial application of torque, S4 was reached between 0.51 and 0.64 seconds after passing the gate. A five-figure summary of this data (Table 8 column 7) is

(0.21, 0.35, 0.38, 0.43, 0.47)

The i.q.r. is 0.085 providing a range of 0.26 to 0.515 indicating the minimum value is a potential outlier, rider 6. However the standard deviation for this data set $\sigma = 0.075$ and the mean $\bar{x} = 0.38$ show that all the data falls within the mean $\pm 2\frac{1}{2}$ SD. The data although slightly skewed are central on the distribution curve with only 0.002 seconds between the median and mean values.

Once the steering passes through neutral at S4 the riders must then steer to the left in order to re-align the motorcycle onto the original direction of travel. How quickly and how much steering is applied determines how quickly the re-orientation is achieved.

Considering that there was no evidence of significant torque being applied during the recovery phase it follows that the steering inputs will not be positive.

As anticipated the majority of the riders were required to make final adjustments by steering to the right immediately prior to the end cones. The riders who did not, riders 8 and 9 did not register neutral steer i.e. zero degrees at the end, it is possible however that in these runs the motorcycle may have been at a slight angle (yaw) but the front wheel was aligned with the cones.

The shape of the graphs from S4 onward is similar to figure 33, there being a number of peaks where the rider had to adjust the steering input. All the riders without exception made at least one adjustment before reaching the peak steering angle for the recovery, in each case the rider reduced the steering input momentarily before increasing to the maximum. In some cases these were very tentative lapses only lasting around 0.03 seconds, others lasted much longer with marked reduction of the steering angle. Riders 6, 7, 8, & 10 only required one adjustment before reaching the peak steering angle. Riders 1 & 9 reached the maximum after one adjustment, reducing the steering and then having to reapply with a lesser input thus taking longer to reach the neutral steer point. The remaining riders gradually built up to a maximum making two adjustments, increasing the steering input on each occasion.

To successfully complete the manoeuvre the recovery stage is critical, if the rider cannot steer back to the left having avoided the cone it is impossible to stop within the final pair of cones. Therefore to make comparisons and to analyse the ability of each rider to successfully recover from the swerve manoeuvre, the time taken from peak avoidance steering to the right at S3 to neutral steer after steering left (the recovery stage) has been examined.

A five-figure summary is;

(1.56, 1.87, 2.03, 2.52, 3.00)

The i.q.r. is 0.65 with a range of 1.23 to 3.16 thus indicating that there are no outliers. The standard deviation for this data set $\sigma = 0.45$ and the mean $\bar{x} = 2.18$ show that all the data falls within the mean ± 2 SD however the data set is slightly skewed.

Statistical analysis of the steering angles achieved during the recovery stage S5 identified that there are no outliers and all the data falls within the mean ± 2 SD. The data is slightly skewed with a difference of 0.0845 between the mean and median values. The five-figure summary for the data is

(1.348, 1.758, 2.778, 3.194, 3.92) with an i.q.r. of 1.436

There does not appear to any direct relationship between the maximum angles recorded and how many adjustments riders were required to make. However if the angles at S3 and the maximum angles during S5 are summed it clearly shows there is a potential relationship with the number of adjustments made, see table 5 below.

Table 5 Combined steering angle and steering adjustments

	Combined Steering Angle and Steering Adjustments			
Run	Angle at S3 (deg)	Max Angle at S5 (deg)	Total (deg)	Adjustments in S5
1	3.122	1.46	4.582	2
2	2.502	2.597	5.099	2
3	3.678	1.348	5.026	2
4	3.655	1.857	5.512	2
5	2.745	3.185	5.93	2
6	3.518	3.22	6.738	1
7	3.29	3.92	7.21	1
8	3.543	2.69	6.233	1
9	2.658	3.15	5.808	2
10	4.259	2.867	7.126	1

Riders 6, 7, 8 & 10 all achieved combined steering inputs of 6.233° and above, as these riders only made one adjustment prior to reaching the maximum steer angle during the recovery phase. This potential relationship is sensitive to the inclusion of the initial countersteering angle. If this angle is also summed then it would be expected that rider 5 should have made only one adjustment as the lowest combined steering input of those riders only making one adjustment would be 6.765° and rider 5 had a combined input of 7.035°.

Figure 36 shows the adjustments made by rider 5 in the recovery phase. The maximum time during any of these adjustments is 0.09 seconds, if this interval is considered to be significant there is no potential relationship, if however 0.09 seconds is considered not to be significant then there does appear to be a potential relationship.

Figure 36 Rider 5 steering input during recovery

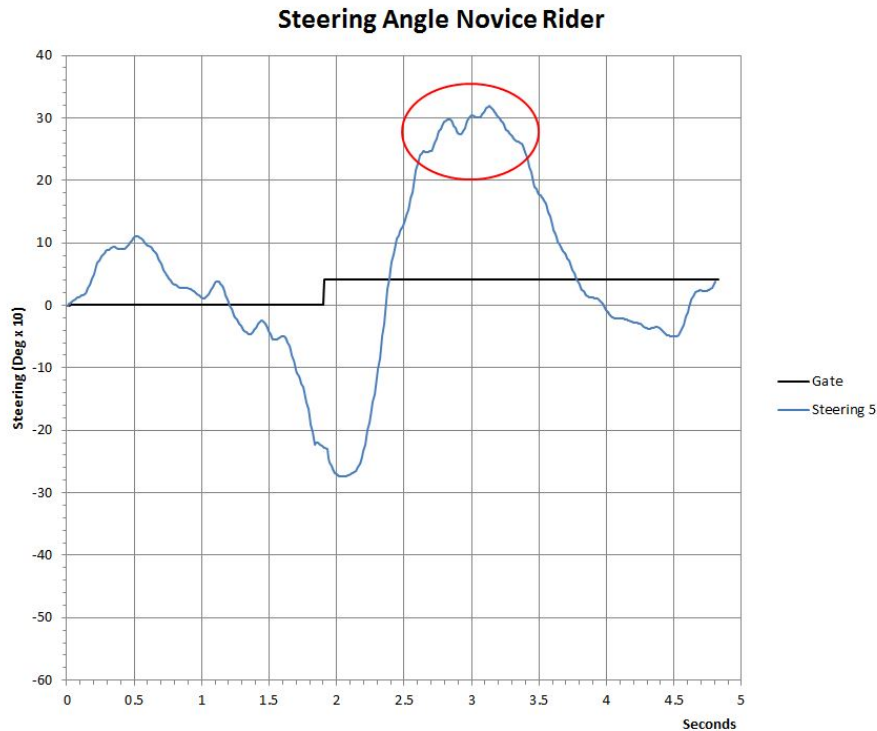

6.2.3 Lean angle

6.2.3.1 Phase 1 The initiation of the swerve

The first section of the graph L1 to L2 does not follow the gradual smooth curve expected. It can clearly be seen from the general plot (figure 37) that the traces do not follow a similar path. Some traces start by rising positively from zero, others remain at zero and then rise, the majority however indicate a smooth negative trace to a maximum at L2. This group can be divided into two sub groups, those who initially lean left and those who do not i.e. riders 1, 4 & 9.

A five-figure statistical summary of the data set 'time to reach L2' (Table 9 column 4) gives

(0.93, 1.01, 1.30, 1.64, 1.85)

The i.q.r. is 0.63 generates a range of 0.375 to 2.273 which includes all the data set without any outliers. The standard deviation for this data set $\sigma=0.33$ and

the mean $\bar{x} = 1.35$ show that all the data falls within the mean $\pm 1\frac{1}{2}$ SD although not particularly well centred.

The maximum lean angle is reached between 1.7 and 2.13 seconds from the first application of steering torque (figure 34) this range is between 0.24 seconds before the gate and 0.19 seconds after having passed through the gate. Those riders reaching L2 before the gate were 1, 2 & 3.

Analysis identifies that all the traces with the exception of rider 9 who achieves the greatest lean angle, reached L2 at a similar point on the graph. There are three traces that initially rise positively from the start indicating a lean to the left, these are riders 2, 5 and 7. Riders 6, 8 and 10 remain close to zero for approximately 0.5 seconds before also rising positively, i.e. leaning to the left. Rider 9 immediately leans to the right, the graph tracking steeply negative. The traces of riders 2 and 5 who initially lean to the left start to drop away within 0.5s and follow the general shape expected i.e. a short positive period followed by a gentle negative curve to L2. Rider 7 however keeps the motorcycle leaning to the left (positive) for over 1s before changing the lean of the motorcycle to the right.

Figure 37 Lean angle plot of the novice group

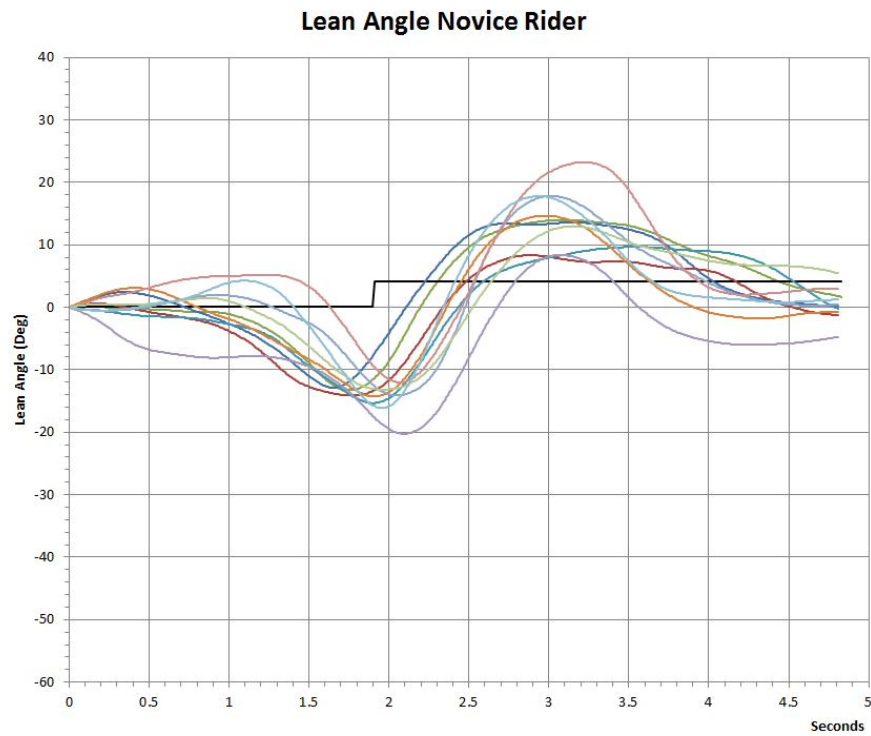

Removing these anomalies from the overall plot only leaves three traces, who follow the expected track i.e. riders 1, 3 and 4 but close examination at the start of the trace for rider 3 identifies that there is an initial period of positive movement before changing to negative figure 38. This positive lean to the left is only 0.57° and is achieved 0.17 seconds after the initial application of the steering torque.

Figure 38 Lean angle plot of novice riders 1, 3 & 4

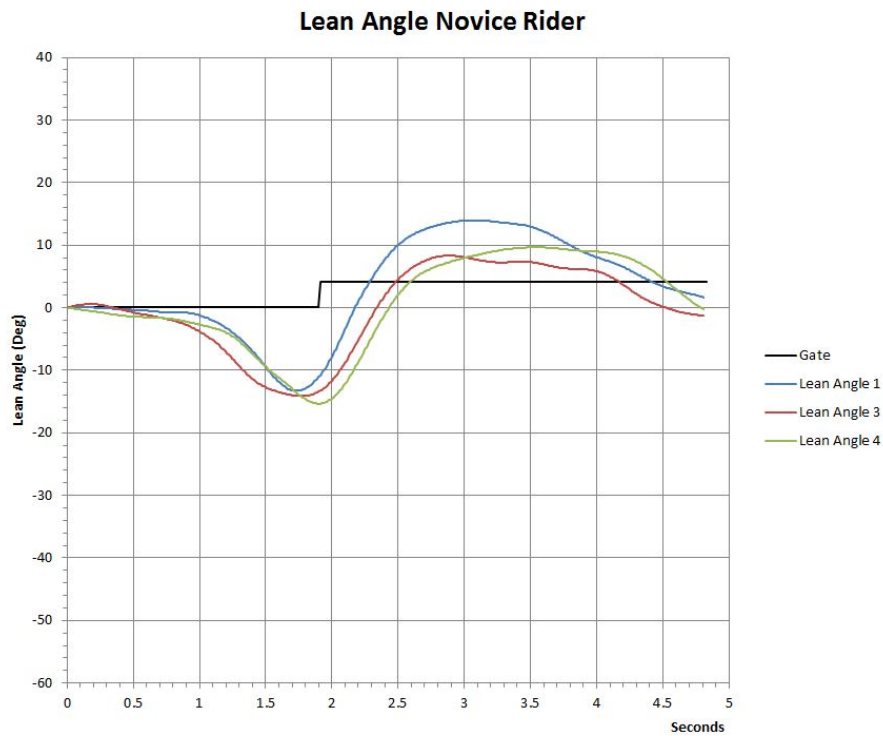

Those riders who lean left either immediately or who delay the lean will return to a similar transition along L1 before reaching L2 the maximum lean. Therefore it appears that all but riders 7 and 9 do in fact meet the generally expected shape of L1. It is obvious that not all riders in this group initiate L1 in the same manner and that there appear to be five ways in which the swerve manoeuvre can be achieved:-

- a gently lean to the right from the start (figure 38)
- an immediate lean to the right (figure 39)
- an immediate short term lean to the left (figure 40)
- an immediate long term lean to the left (figure 41)
- a delayed short term lean to the left (figure 42)

Figure 39 Immediate lean to the right

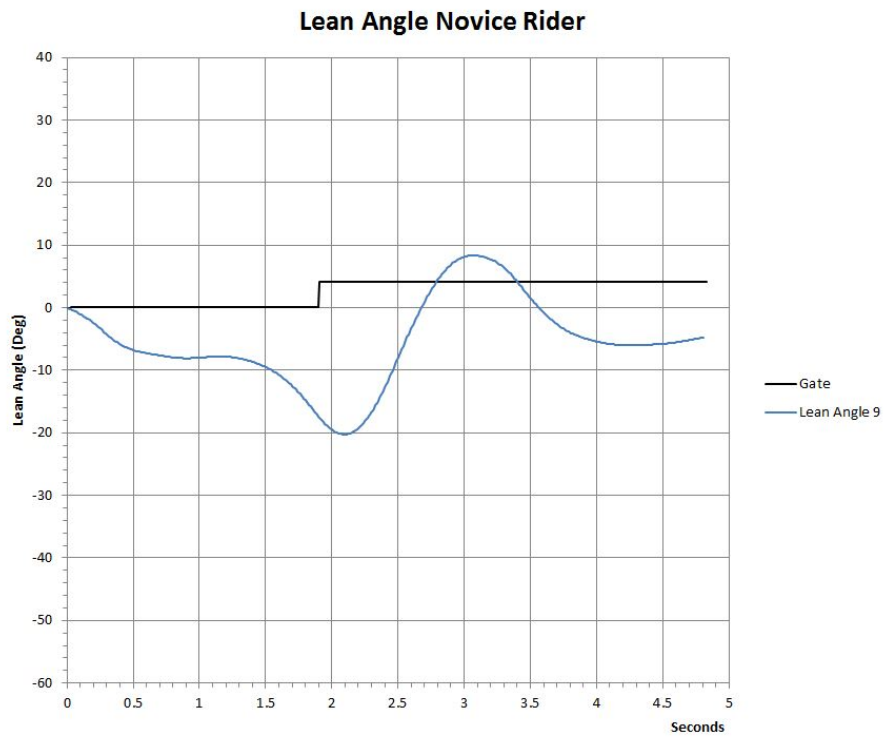

Figure 40 Immediate short period lean to the left

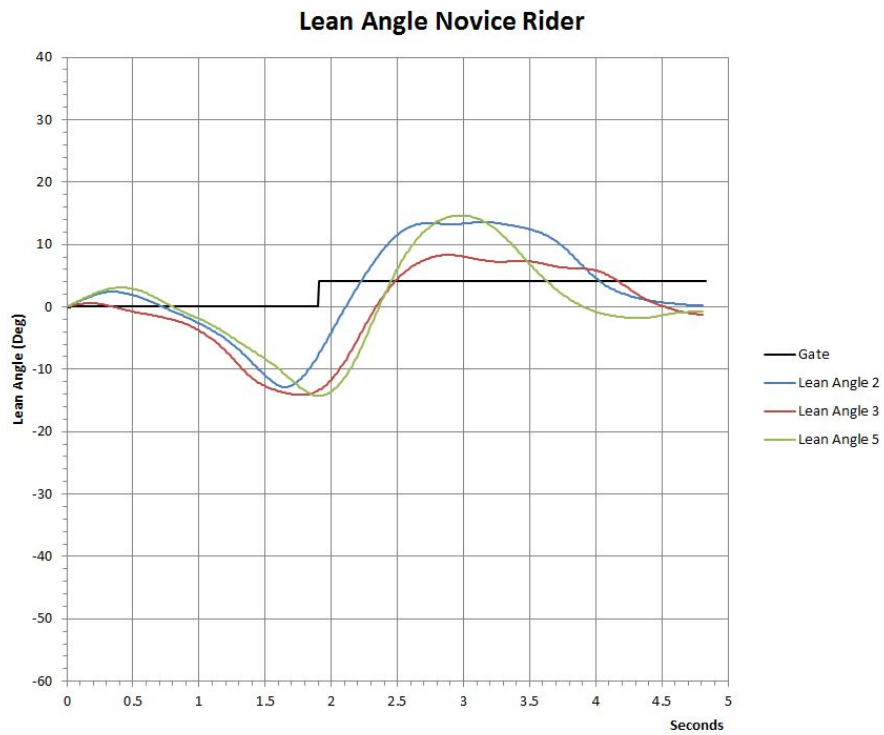

Figure 41 Immediate long term lean to the left

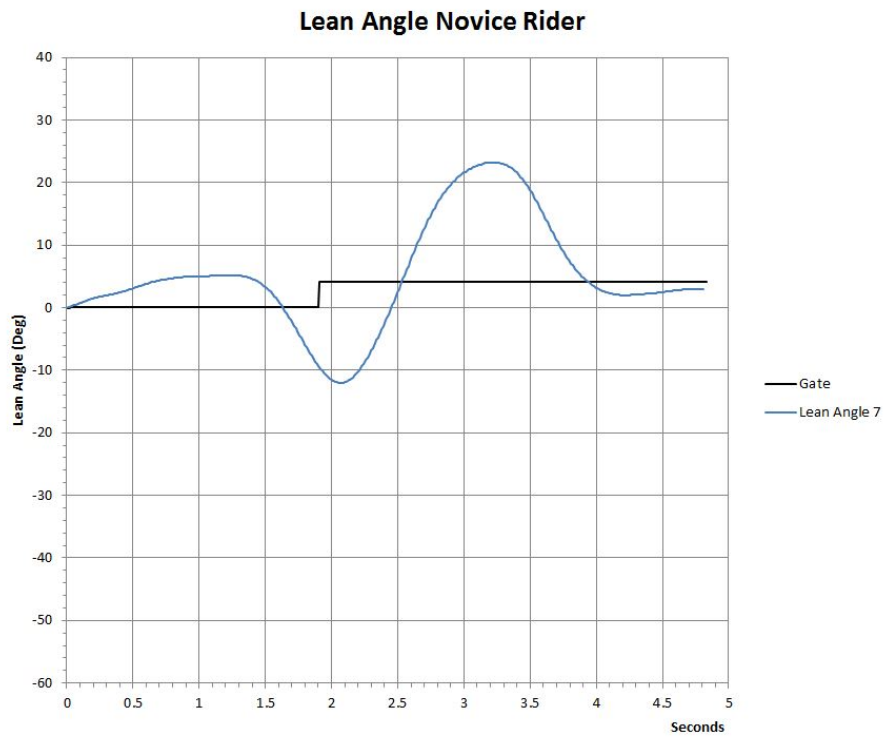
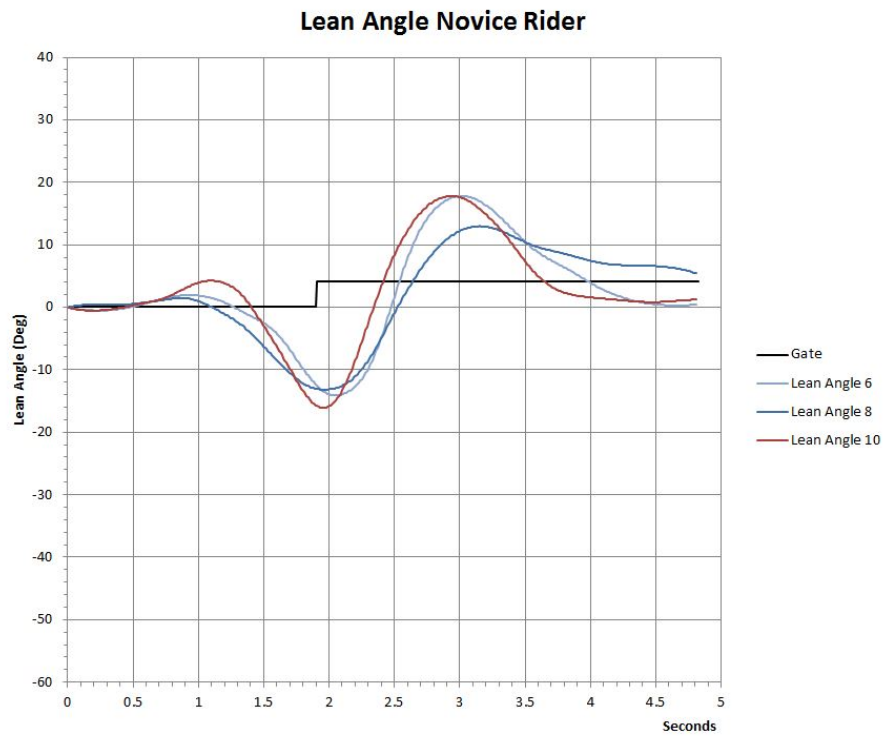

Figure 42 Delayed short period lean to the left



6.2.3.2 Phase 2 The lean angle during the transition and recovery

The lean angle and direction during the transition/recovery phase of the manoeuvre do not appear to be too dissimilar. The slopes of the curves do mirror the steering application during the same phase and because of the way in which the lean angle is determined the resultant curve is considerably smoothed.

In this phase of the manoeuvre it is difficult to make any direct comparisons between the lean angle and any other component. Due to the manner in which this sector of the manoeuvre is been executed, once the swerve has been initiated and the maximum torque at T3 and the max steering at S3 have been reached, the riders only have to recover the motorcycle onto the original path.

The steering input at S3 should be reflected in the lean angle of the motorcycle and rider as the motorcycle passes the avoidance cone.

Figure 43 Novice rider passing the avoidance cone



Figure 43 has been selected from the video footage. Using the shadow produced by the motorcycle it is possible to identify the point at which the motorcycle passes the cone. It can be seen that as this particular novice rider passes the avoidance cone there is little difference if any between the angle of the motorcycle and the angle of the rider i.e. the rider and motorcycle are on the same alignment. This orientation was typical of this rider group. It was noted that all the riders in this group passed close to the cone.

The lean angle taken from figure 43 is approximately 13° from the vertical. The range of lean angles recorded for the novice group at L4 was between 8.32° and 23.23° . The mean lean angle is 14.03° (table 9).

A five-figure summary for this data is:-

(8.32, 9.32, 13.78, 17.79, 23.23) with an i.q.r. of 8.47

The standard deviation for this data set $\sigma = 4.7$ and the mean $\bar{x} = 14.03$ show that all the data falls within the mean $\pm 2SD$.

Examination of the motorcycles front wheel in figure 43 identifies that the nearside wheel rim is visible to the camera. The camera was set in line with the cones on the right hand side of the track. Therefore the rider has not started to steer back onto the original course. The white arrow in figure 43 indicates the visible section of wheel rim in this aspect.

6.2.4 Yaw Angle

The yaw angle is determined by how quickly the rider applies the initial torque to the handlebars and the steering angle achieved. Overall the novice group produce a 'tight' graph with all the riders following a generally neutral trace for about the first 1.5 seconds. After this the trace is generally positive (counter

clockwise yaw) before changing direction and levelling out to the end of the manoeuvre.

The yaw angle plot for the novice group figure 44 does suggest that all the riders are initiating similar forces which are causing the motorcycle to move in similar ways.

Figure 44 Yaw angle plot novice riders

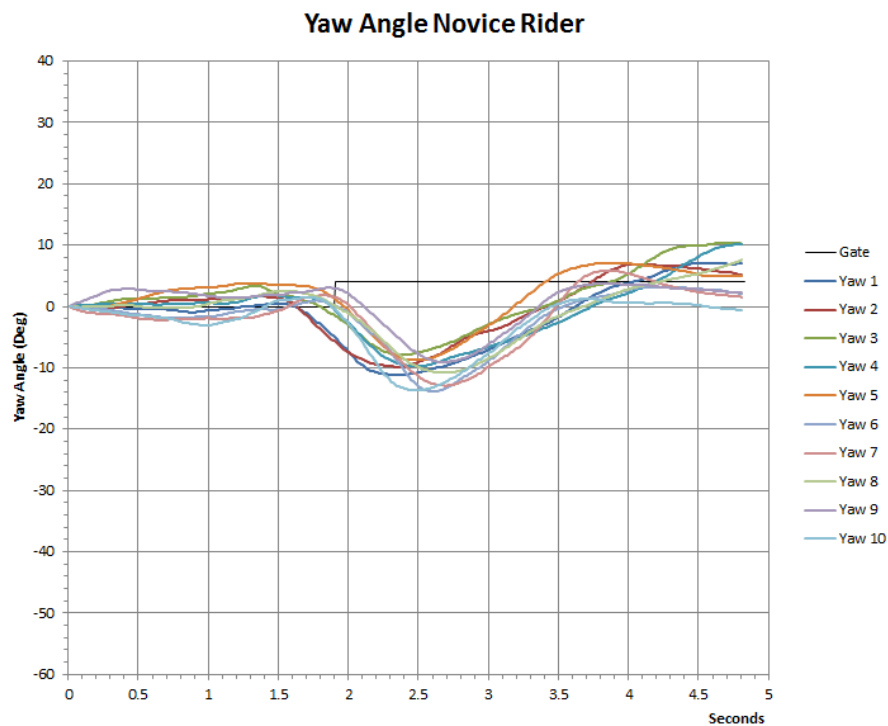

The mean angle and time to reach Y1 was -2.08° achieved in 1.02 seconds. The maximum yaw angle was reached between 0.69 and 1.33 seconds, this is between 0.56 seconds and 0.03 seconds before the gate. The time interval from Y1 to Y2 should be commensurate with the intervals between T1 to T3, S1 to S3. The five-figure summary for the data is

(0.77, 0.82, 0.94, 1.06, 1.16) with an i.q.r. of 0.24

The standard deviation for this data set $\sigma = 0.13$ and the mean $\bar{x} = 0.95$ show that all the data falls within the mean $\pm 2SD$.

The data analysis reveals that four of the riders, 1, 6, 7 & 10 did not initially yaw in a positive (counterclockwise) direction, the direction the machine would move with positive countersteer. They all yawed to the right before yawing left at the initiation of the turn. The plot of these riders clearly shows this change in the yaw direction prior to Y1 figure 45.

Figure 45 Yaw angle novice rides 1, 6, 7 & 10

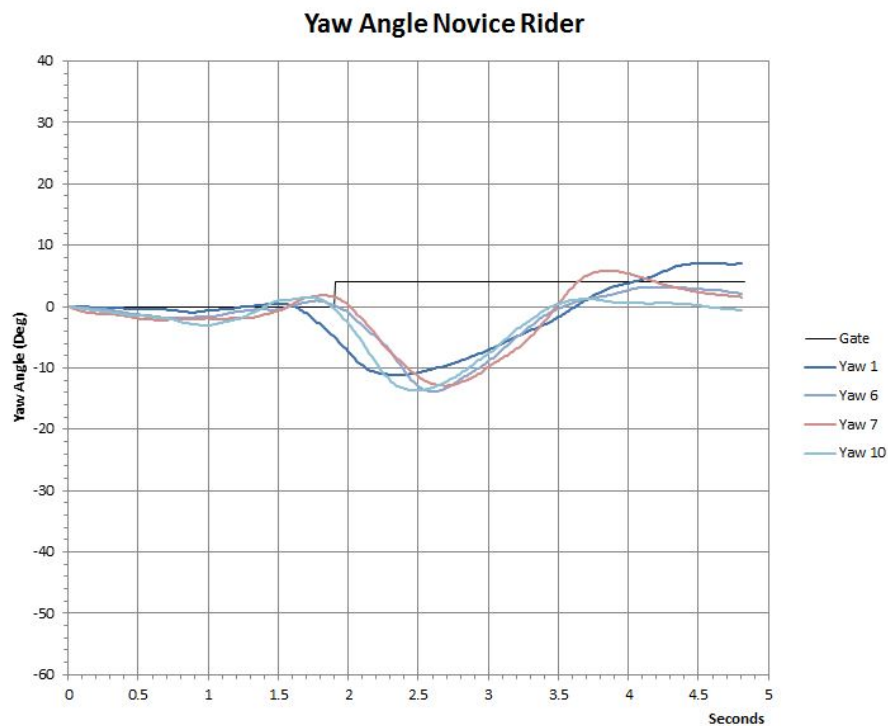

Riders 2, 3, 5 & 9 all the yawed to the left at Y1 as expected, however the duration of the yaw lasted in the region of 1.8 seconds figure 45. Only two riders, riders 4 & 8 produced graphs as expected where the anticlockwise yaw is consistent with the initiation of the turn i.e. the initial countersteer to the left figure 47.

Figure 46 Yaw angles novice riders 6, 7 & 10

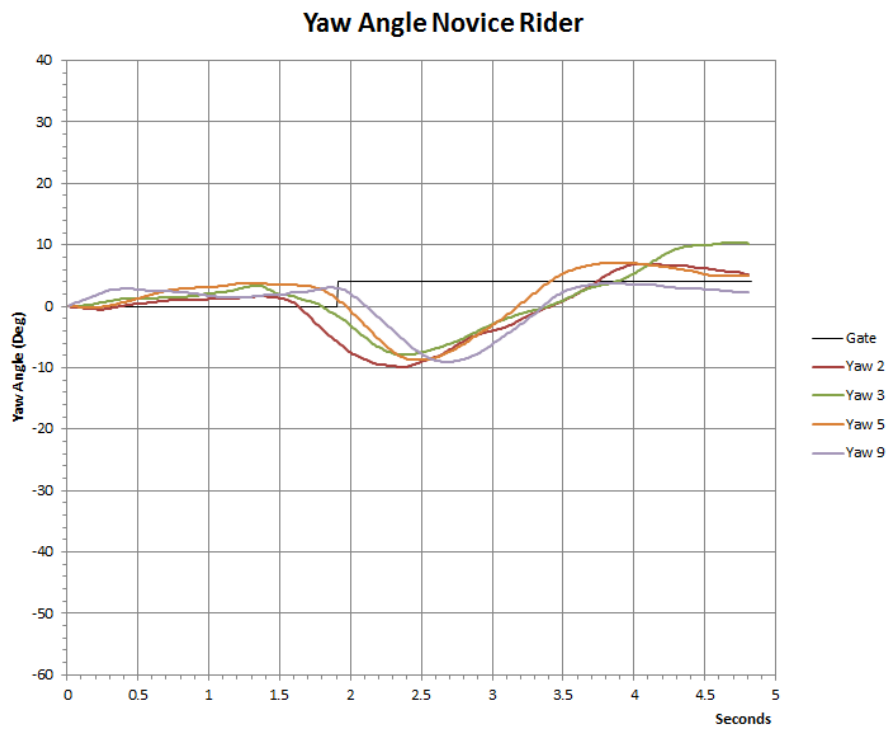
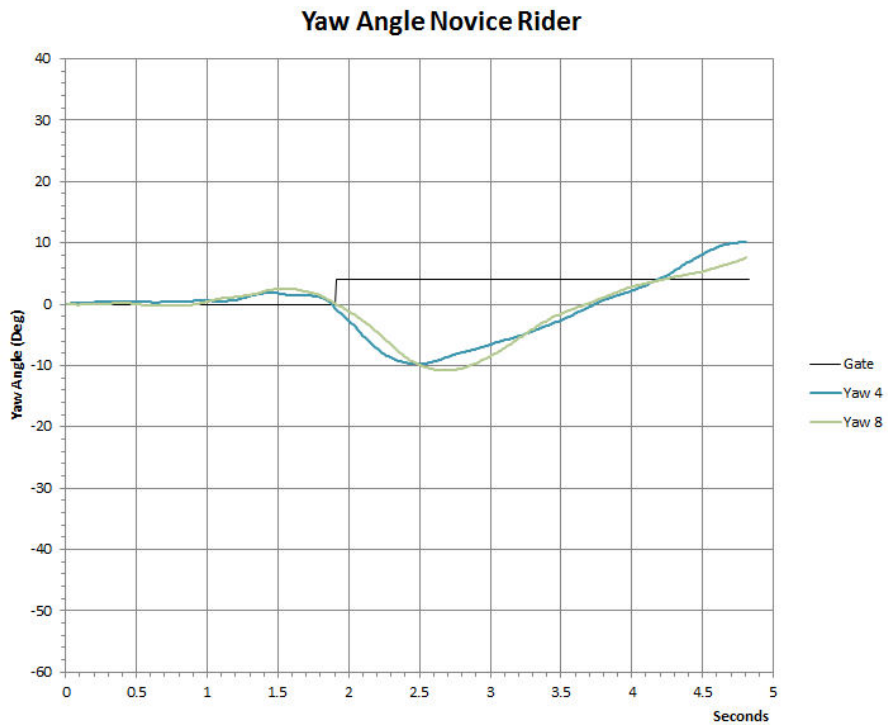

Figure 47 Yaw angles novice riders 4 & 8



The angle at Y2 is crucial in the rider's attempt to successfully pass the cone.

The five-figure summary is

(7.88, 8.99, 10.33, 13.12, 13.86) with an i.q.r. of 4.13°

The standard deviation for this data set $\sigma = 2.1$ and the mean $\bar{x} = 10.78^\circ$ show that all the data falls within the mean $\pm 2SD$. The mean and median are well centred although the i.q.r. is nearly twice the standard deviation.

Phase 2 The yaw angle during the transition and recovery

There are no significant issues during the transition and recovery phase. All the riders managed to follow a similar path between Y2 the maximum yaw in the region of the cone and Y4. It is impossible from the data available to identify exactly at what point the riders passed the cone.

6.2.5 Observations novice rider group

The manner in which the rider applies the force to the handlebars appears to be erratic and inconsistent. There are a number of observations which have been identified.

In some instances there are in effect two peaks during the initial application of the steering force. Where there are two clearly identifiable peaks the greatest force has a magnitude close to the mean. In some cases the first peak is the maximum force in others it is the second. The overall effect is that the force, although reduced in magnitude to the single peak applications is longer in duration, i.e. the initial countersteering action to induce the turn takes longer.

The percentage differences between the forces applied at T1, the initial countersteer and T3 the 'swerve' were found to be 0.91% and 1.37% respectively. When compared to the corresponding steering angles it was found that the magnitudes of the percentage differences are reversed. At S1, the countersteer angle and S3 the 'swerve' angle, the percentage differences are 1.5% and 0.52% respectively.

The respective time intervals between T1 to T3, S1 to S3 and Y1 to Y2 are not consistent with magnitudes of 0.85s to 1.1s and 0.95s respectively.

It is also evident within this novice group that the riders as they pass the avoidance cone have not started to steer back to the left and that the rider does not lean with the motorcycle.

6.3 Group 2 The Experienced Riders

Figure 48 gives a visual representation of the manoeuvre being undertaken by an experienced rider from a head-on viewpoint.

Figure 48 Visual representation experienced rider

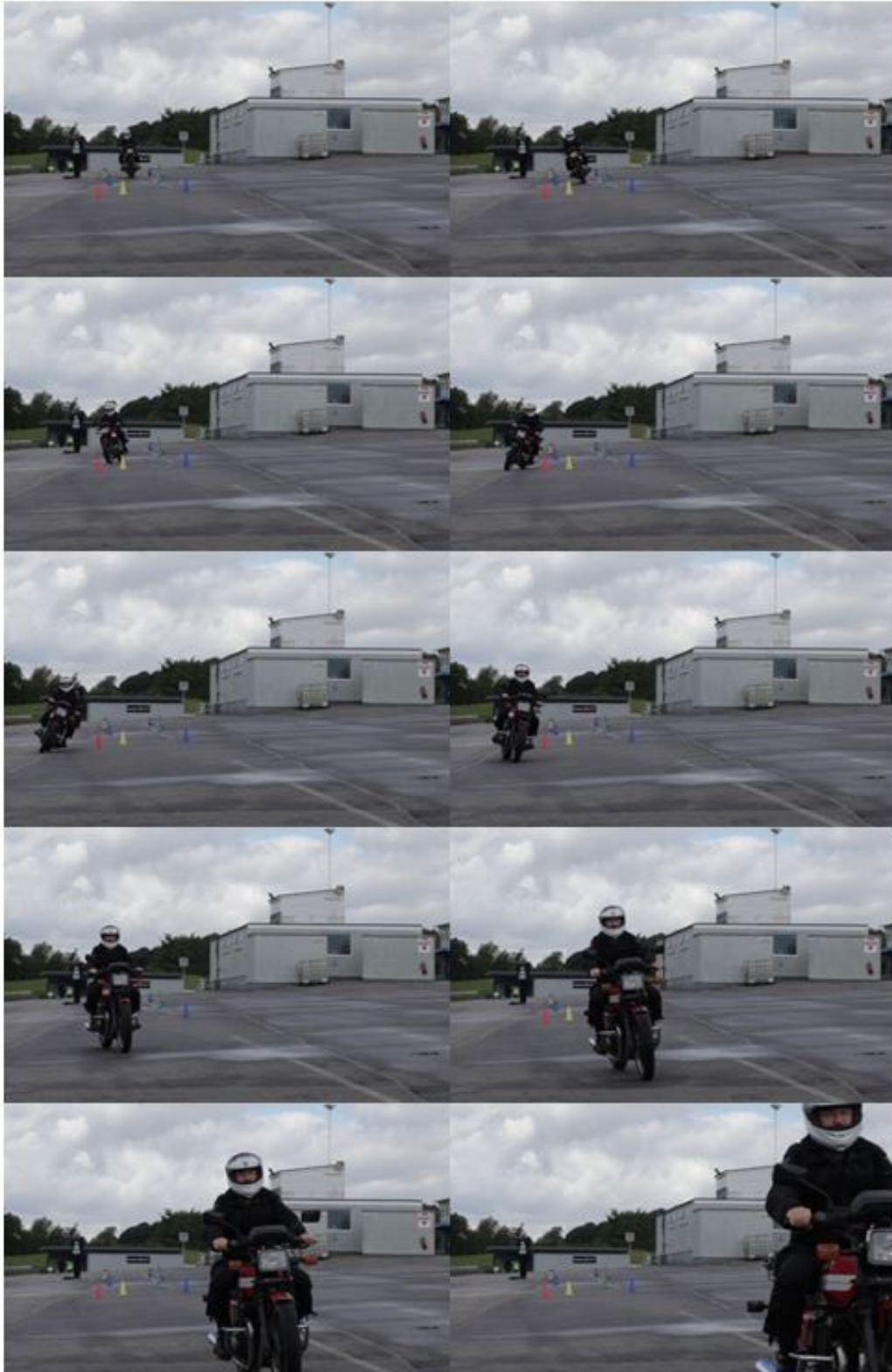

The course to be manoeuvred is exactly the same for all groups within this research, however comparing figure 48 to figure 28 there are clearly identifiable differences in the position and attitude of the motorcycle at various stages during the execution. There are also differences in the attitude (alignment of rider to the motorcycle) of the rider at various points along the course. This aspect of rider motorcycle servomechanism will be discussed later.

As with the novice group 10 tests have been selected for analysis, each of which was ridden by an experienced rider with a full UK motorcycle licence. It is possible that within this group there are riders who obtained their motorcycle license prior to the introduction of the new DOT 'off road' assessment and as a consequence some of the riders may not have seen or attempted this manoeuvre prior to evaluation. Consideration has been given to excluding these riders, however this evasive manoeuvre is not one which is uncommon especially to an experienced rider and the fact that it was not part of the rider's initial test should not be considered as a reason for exclusion.

6.3.1 Torque

6.3.1.1 Phase 1 The initiation of the swerve

As previously stated to visually identify any potential differences between the riders in this group and the other groups, all the data has been calibrated to the pulse from the gate sensor (1.94 seconds). This has enabled all the data to be graphed about a known impulse as the motorcycle's front wheel passes between the last cones immediately prior to the swerve.

Figure 49 is the overlaid plot of this particular group and when compared to the novice group figure 30 it is obvious that there are considerably more similarities

in the manner the experienced riders apply this initial countersteering force compared to the novice riders. Although the graph does suggest there are considerable similarities it is the initial application of torque, 'the countersteer', is where there are again identifiable differences in the way riders apply this steering.

Figure 49 Torque plot of the experienced group

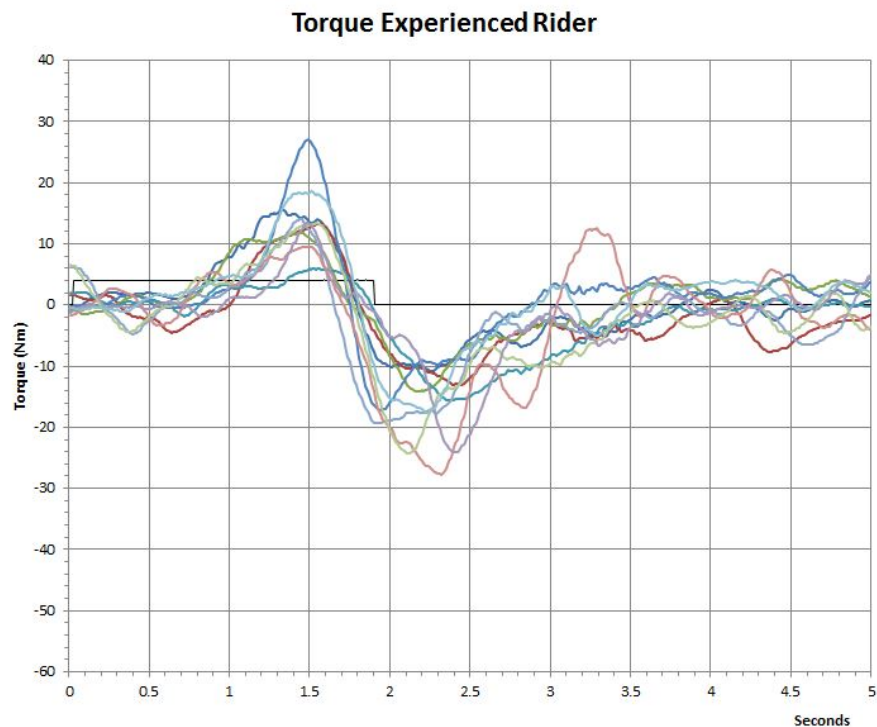

The shape of the traces from zero to T1 tends to remain at zero or close to zero before rising to T1, it is the gradient and 'noise' associated with these traces where the significant differences are expected. It was anticipated that the more experience the riders have accrued, the more compact and coincidental that T1 would be. The peak at T1 does appear to be more clearly defined with the individuals applying the peak force at similar times before the gate. However closer examination does reveal that some of the riders apply a progressive force to the steering over a longer period and only reach a moderate maximum at T1,

whereas others apply the force more quickly over a shorter period and often this force is of a much greater magnitude.

The range of forces recorded for this particular group at T1 where the maximum countersteering force ends is much greater than expected and ranged from 5.995Nm some 3Nm less than the novice group to 26.995Nm which is 2.76Nm greater than the novice group. The mean of this group is 14.27Nm compared to the mean of 16.79Nm achieved by the novice group.

T1 is achieved between 1.38 and 1.62 seconds (figure 49), i.e. between 0.32 and 0.56 seconds before passing through the gate. The time taken to reach maximum countersteer at T1 in order to initiate the turn is between 0.53 seconds to 1.09 seconds from the first application of positive torque and the mean time is 0.77 seconds.

Considering the sample data of the time interval from the initiation of the steering torque to reaching the 'gate' (Table 6 column 2) a five-figure summary lists (0.32, 0.35, 0.4, 0.46, 0.56)

If the i.q.r. (interquartile range) of 0.11 is applied to the lower and upper quartiles there are no outliers and the data set is not skewed about the mean $\bar{x} = 0.41$. The standard deviation of this data $\sigma = 0.072$, therefore the mean ± 3 SD covers this data set.

Comparing the experienced riders of this group against the novice group there is a reduction of 8.98% in the mean time taken to initiate the countersteer and to reach the maximum torque at T1 (Table 11 column 3). A five-figure summary is

(0.53, 0.6, 0.76, 0.86, 1.09)

The i.q.r. is 0.255 and when applied to the lower and upper quartiles there are no outliers. The standard deviation $\sigma = 0.16$, therefore the mean $\bar{x} = 0.77 \pm 2$

SD includes all the data set confirming that this particular group again falls within the 95th percentile.

Finally the torque applied at T1 (Table 11 column 4) is subjected to the same rigour, the five-figure summary is

(6.00, 11.24, 13.46, 16.29, 27.00)

The i.q.r. is 5.05 which suggests there are two potential outliers, 6.00 and 27.00. When compared to the previous group the lower value of 5.995Nm is low and unexpected. The higher value is not unexpected because as riders gain more experience it is reasonable to assume that their ability to apply quick, firm precise steering should increase.

The standard deviation for this data set is $\sigma = 5.6$ and a mean of $\bar{x} = 14.27$. Again in this case all the data including the two potential outliers is within the mean $\pm 2\frac{1}{2}$ SD.

The manner in which the individual riders apply the initial countersteering force appears to fall into three distinct categories, those who:-

- apply the force firmly to reach a maximum
- apply a force and then apply a second force
- gently increase the force followed by a defined increase in force to the maximum

Rider's 1, 2, 3, 5, 6 & 9 fall into the first category where the countersteering force is applied in a clearly defined curve figure 50. The time period during which the force is applied does vary as does the maximum force but the general shape of the curve is the same. However the mean time interval for the application is 0.70 seconds.

Figure 50 Torque plot for experienced riders 1, 2, 3, 5, 6 & 9

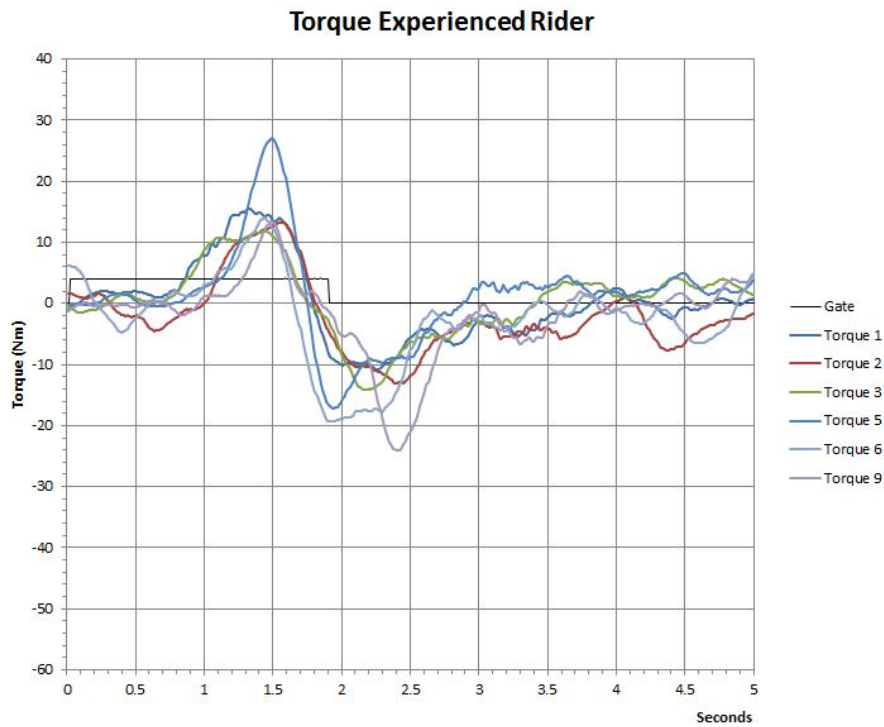

The second category comprised riders 4, 7 & 8 see (figure 51). All of these riders initially apply a steering force and start building the force but then either do not continue to increase the force or allow the force to relax slightly before then apply a greater force to complete the input. The time interval for the overall application is greater than for the first group by 0.11 seconds or 16%.

There was only one rider, rider 10 in the final category figure 52. This rider initially applied a force and gently increased the force to approximately 4Nm before suddenly increasing the force to approximately 18Nm to complete the application. The time interval to reach the maximum was 0.40 seconds longer than the first and 0.28 seconds longer than the second category, 56% and 35% longer respectively.

Figure 51 Torque experienced riders 4, 7 & 8

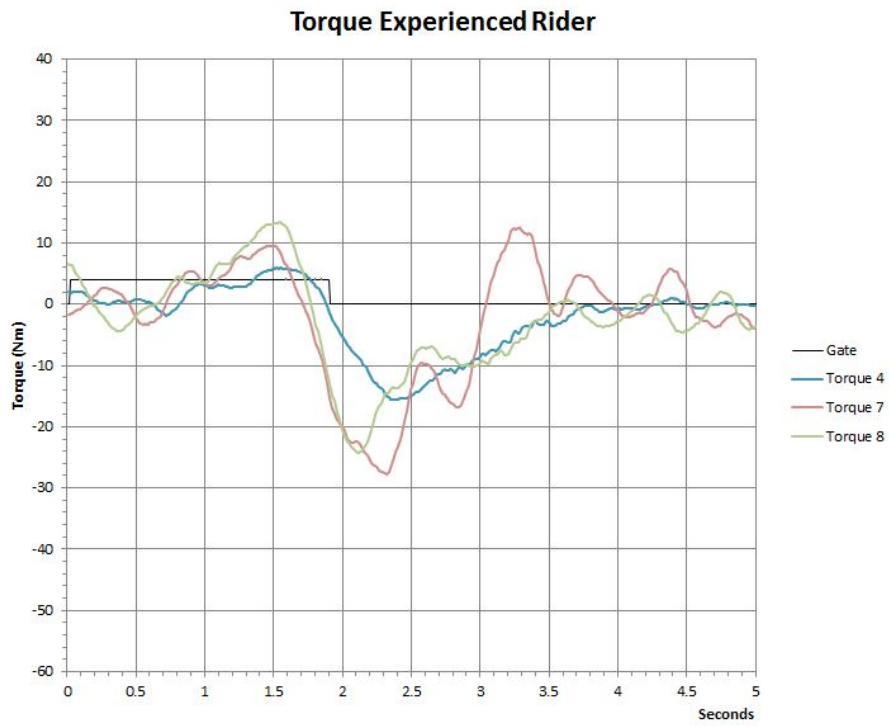
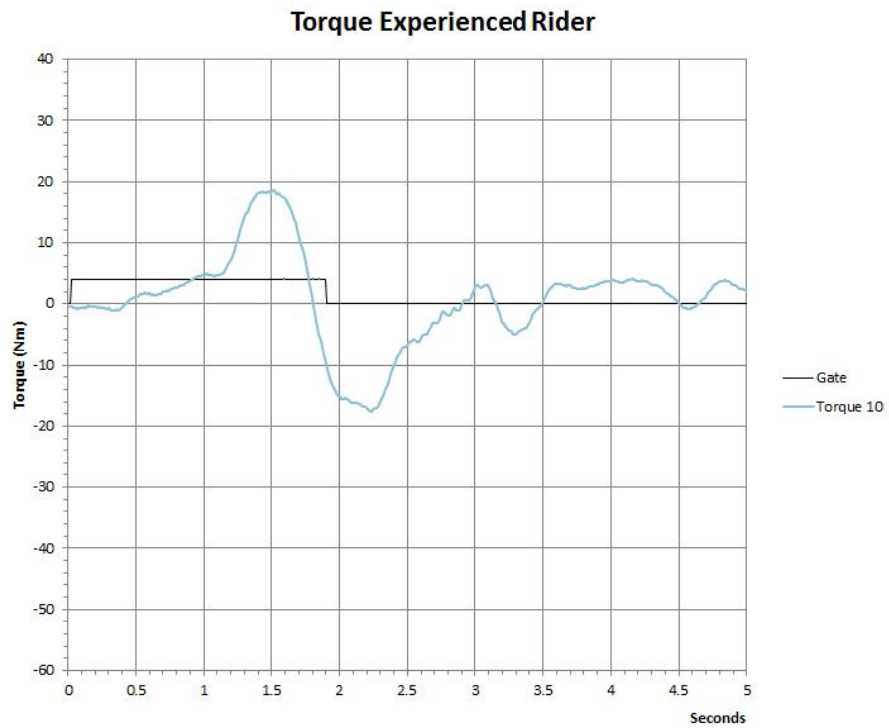

Figure 52 Torque experienced rider 10



Taking the transition from T1, through T2 (zero) and to T3 the maximum anti-clockwise torque as a single component the time taken from the commencement of the initial countersteer at zero was between 1.15 second and 1.81 seconds with a mean of 1.497 seconds. However, the intermediate time from T1 to T3 ranged from 0.43 seconds to 0.93 seconds with a mean of 0.729 seconds. The five-figure summary for this intermediate time T1 to T3 (Table 11 column 5) is

(0.43, 0.55, 0.78, 0.86, 0.93) with an i.q.r. of 0.31

The data fits well within the mean $\pm 2SD$, the SD $\sigma = 0.17$ and the mean $\bar{x} = 0.73$.

The mean value of 0.73 seconds is a reduction of 15.6% over the novice group for this period. The range of force applied at T3 was between 10.79Nm and 27.71Nm with a mean of 18.37Nm. The five-figure summary for these values (Table 6 column 6) is

(10.79, 13.85, 17.32, 24.19, 27.71) with an i.q.r. of 10.34

The standard deviation $\sigma = 5.5$ and the mean $\bar{x} = 18.37$ identify that the data set does fit within the mean ± 2 SD but the data is skewed about the median.

Again this group applied a significantly larger force at T3 being 24.59% greater.

6.3.1.2 Phase 2 The torque forces during the transition and recovery

The recovery phase as stated earlier is the phase where the rider steers back towards the initial direction of travel. Only one rider, rider number 7 reduced the torque to zero and applied anti-clockwise torque before reducing the torque to zero and attaining the original line of travel. Figure 53 below shows this anti-clockwise torque being applied between 3 and 3.5 second.

Figure 53 Recover torque experienced rider 7

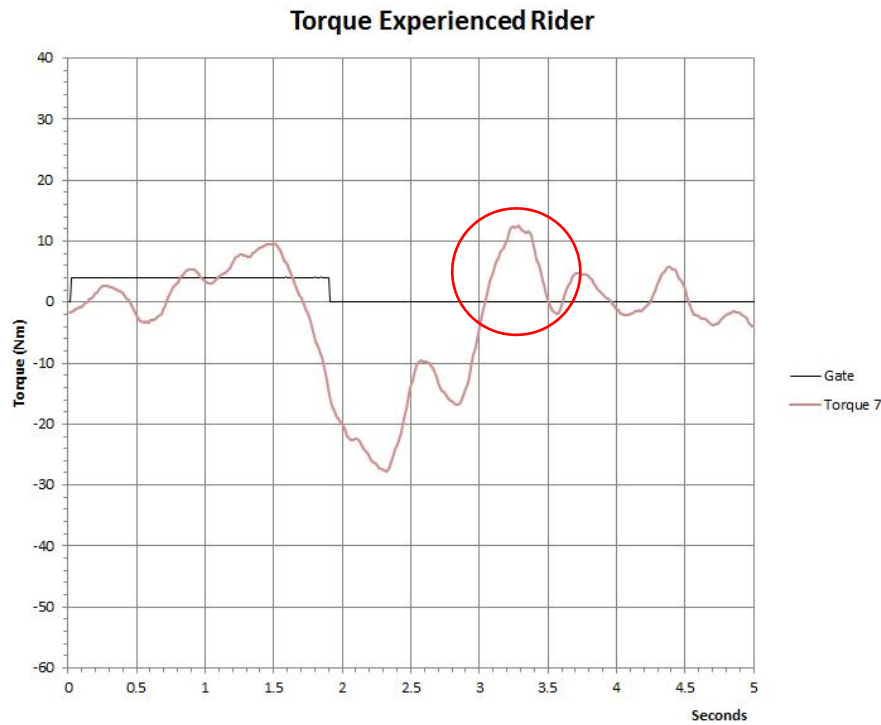

Other riders did return to neutral torque more quickly than others but as stated only rider 7 applied the significant anti-clockwise torque causing the positive trace as identified in figure 51. Riders 3, 5, 6, 9, & 10 are the quickest to achieve neutral torque but as stated within the novice analysis it may be that in this particular scenario the riders recognised that there was no necessity to do this quickly as there was sufficient distance / time remaining.

6.3.2 Steering angle

6.3.2.1 Phase 1 The initiation of the swerve

The most noticeable difference between the novice group and this group in relation to the steering angles is the smoothness of the graph between S2 to S3 and back to S4 i.e. the steering application immediately post the countersteer. Figure 54 shows the experienced groups steering inputs.

Figure 54 Steering angles experienced riders

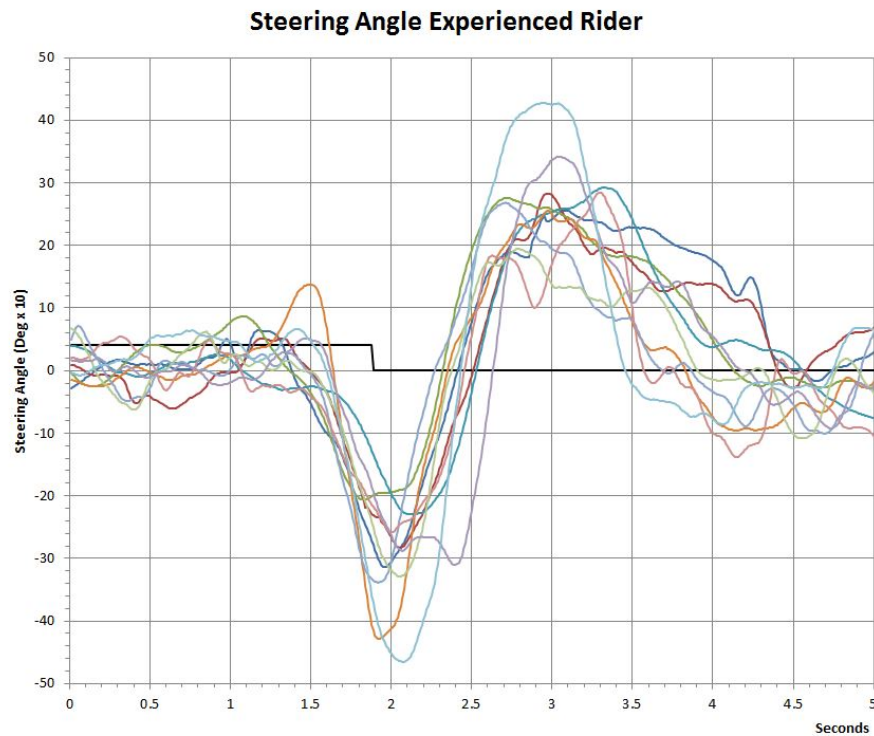

There have been three different ways in which the steering torque has been applied in this group and it follows that there should be some discrepancies identified within the initial counter steering angles.

The angle achieved at countersteer ranged between 0.25° and 1.38° a 440% difference compared to the novice group where there was a 605% difference. A five-figure summary clearly shows that 1.38 is in fact a potential outlier.

(0.25, 0.43, 0.57, 0.72, 1.38)

The i.q.r. is 0.288 which when applied to the upper and lower quartiles confirms that 1.38 is an outlier. The standard deviation for this data set is $\sigma = 0.32$ with a mean of $\bar{x} = 0.62$, therefore 1.38 falls outside the mean $\pm 2\frac{1}{2}$ SD and it would be expected that only approximately 1.25% of the population would achieve this result. Table 12 gives a breakdown of the steering data.

Comparing the median value at S1 for experienced group against the same value for the novice group identifies that the experienced group applied a smaller counter steer angle, 0.569° and 0.857° respectively representing a 51% reduction in this critical steering input.

During the same phase the data from the novice group showed significant noise within the plot. The data for this group, the experienced group identified that there was much less noise and the initial countersteering application could be divided into three distinct categories. Those who:-

- held steady neutral, then steered left to maximum
- initially steered right and then left to maximum
- gentle steering to the left with adjustments

Five of the riders, riders 1, 4, 5, 6, & 9 held a steady neutral steer before applying the countersteer, four riders, 2, 3, 7, & 8 steered right and then left and only one rider, rider 10 who applied a gentle steering force to the left made one adjustment before reaching the peak countersteer. This suggests that this group of riders are more positive in their steering i.e. not constantly making adjustments on the approach, an attribute which is expected to develop with experience.

It was identified within the novice group that some riders achieved peak countersteer (S1) and peak torque (T1) at approximately the same time. This phenomenon is also present in this group and there is a strong relationship between the three categories identified in relation to how the countersteer angle is applied. In the first category where the steering is held steady before application of the steering the peak torque (T1) coincides with the peak countersteer (S1). In the second and third category S1 is reached before T1. A good example of this can be seen in the data of rider 9, see figure 55 below.

Figure 55 Coincidental peak countersteer and torque

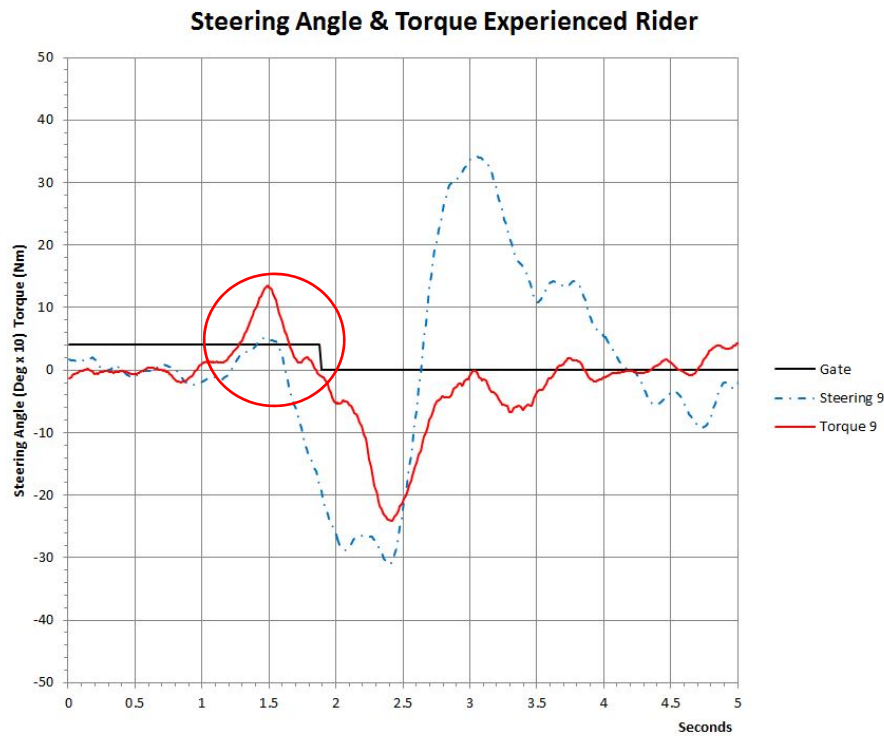

The time taken to achieve the peak countersteer angle at S1 is crucial in a rider's ability to steer / swerve quickly and it was expected that as riders gained more experience this time would reduce. This group had a mean time of 0.47 seconds compared to the novice groups of 0.77 seconds, achieving the peak countersteer (S1) some 14% slower.

The transition from S1 back to neutral (S2) and on to S3 the maximum steering angle to avoid the cone is much more compact than the novice group. The steering angles ranged from 2.06° to 4.65°. A five-figure summary of the data (Table 12 column 4) gives:-

(2.06, 2.52, 3.01, 3.61, 4.65) with an i.q.r. of 1.09.

There are no potential outliers and the whole data set fits well with in the mean $\pm 2SD$. The standard deviation for this data set is $\sigma = 0.82$ with a mean of $\bar{x} = 3.14$. The corresponding time interval between S1 and S3, peak

countersteer to peak avoidance ranged from 0.43 seconds to 1.21 seconds. A five-figure summary for this data (Table 12 column 5) provides:-

(0.43, 0.59, 0.75, 1.14, 1.21) with an i.q.r. of 0.56

Again there are no outliers the standard deviation for this data set is $\sigma = 0.80$ with a mean of $\bar{x} = 0.28$ and the data set fits within the mean ± 1.5 SD

6.3.2.2 Phase 2 The steering angles during the transition and recovery

Having achieved the maximum steering angle to avoid the cone S3 the rider must recover and return to the original direction of travel. The time interval from S3 to neutral steer at S4 is an indication of how quickly the rider removes the swerve steering before steering to the left to regain the original line of travel. A five-figure summary shows that the median value is 0.44 seconds for this group compared to 0.375 seconds for the novice group an increase of 17%.

(0.33, 0.35, 0.44, 0.47, 0.56) with an i.q.r. of 0.12

It is notable that the overall range of times for the experienced group is only 0.03 seconds quicker than for the novices.

As stated previously once the steering passes through neutral at S4 the riders must then steer to the left in order to re-align the motorcycle onto the original direction of travel. How quickly and how much steering is applied determines how quickly the re-orientation is achieved.

Only one rider has been identified as applying significant anti-clockwise torque into the steering during the recovery phase. As identified during the review of the novice data there did appear to be a possible relationship between the total steering put into the system and the number of steering corrections / adjustment required during the recovery phase to reach the maximum steering angle during

S5. When the same analysis is applied to this group there does not appear to be a similar relationship. Six riders did not make any adjustment before reaching the maximum steer angle and the remaining four only made one adjustment see table 6 below.

Table 6 Combined steering angle and adjustment experienced riders

Combined Steering Angle and Steering Adjustments				
Run	Angle at S3 (deg)	Max Angle at S5 (deg)	Total (deg)	Adjustments in S5
1	3.139	2.559	5.698	1
2	2.83	2.831	5.661	0
3	2.064	2.759	4.823	0
4	2.295	2.928	5.223	0
5	4.292	2.425	6.717	1
6	3.383	2.682	6.065	0
7	2.588	2.847	5.435	1
8	3.29	1.948	5.238	1
9	2.877	3.408	6.285	0
10	4.65	4.276	8.926	0

Analysis of the maximum angles achieved during S5, the recovery phase shows that the median value only varies after 2dp

(1.948, 2.526, 2.777, 3.048, 4.276) with an i.q.r. of 0.523.

The standard deviation for this data set is $\sigma = 0.62$ with a mean of $\bar{x} = 2.87$ the data set all fit within the mean $\pm 2\frac{1}{2}$ SD. The mean value increases by 0.24° for this particular group.

6.3.3 Lean angle

6.3.3.1 Phase 1 The initiation of the swerve

Three categories of steering inputs were identified in the last section, it follows that there should potentially be a similar number of categories in relation to the lean angle. An overview graph of the lean angles achieved by this group is below, figure 56.

Figure 56 Lean angles experienced riders

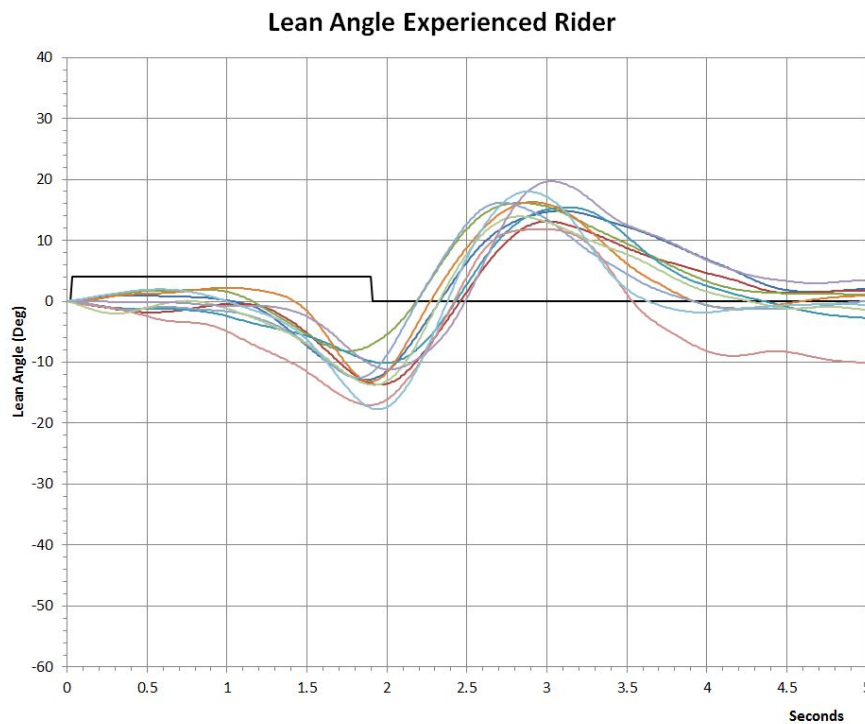

There were five categories identified for the novice group. Four of those categories were also present in this particular group. There was no delayed short term lean to the left leaving four categories:-

- a gently lean to the right from the start
- an immediate lean to the right
- an immediate short term lean to the left
- an immediate long term lean to the left

The majority of the riders, riders 2, 6, 8 & 9 all initiated the turn with a gentle lean to the right from the start which suddenly increased to a maximum. Riders' 4 & 7 made the immediate lean to the right. Riders 1 & 10 made the immediate lean to the left and riders' 3 & 5 made a long term lean to the left. Table 13.

When comparing the steering input to the riders' lean attitude it is reasonable to assume that the rider will lean in the direction of steer. This does not appear to be applicable to the initiation of the turn. Riders 1, 4, 5, 6, & 9 all held a steady neutral steer before applying the countersteer. Only two of these riders, riders 1 & 5 actually leaned to the left during the initial countersteer. However rider 1 made an immediate short term left lean to the left. Rider 5 however, although immediately leaning left, leaned for a longer period. Two other riders, riders 3 and 10 also leaned to the left, rider 3 held the lean for a long term but rider 10 made the short term lean. So although they fall into the same categories as riders 1 and 5 their initial steering input is totally different suggesting that there may be some rider servo-mechanism influence in this early stage of the motorcycle lean.

Statistical analysis of time taken to reach L2 and the maximum angle achieved at L2 show that the median time was 1.18 seconds and that the median angle was -13.01° . A five-figure summary of the time between L2 and L4 is

(0.95, 1.11, 1.18, 1.24, 1.52) with an i.q.r. of 0.99 to 1.35.

This suggests that there are two potential outliers at 0.95 and 1.52. However the standard deviation for this data set is $\sigma = 0.15$ with a mean of $\bar{x} = 1.19$ which shows that all the data including the two potential outliers are within $\pm 2.5SD$ of the mean. In relation to the angle achieved at L2, a five-figure summary is;

(8.17, 10.92, 13.01, 14.55, 17.74) with an i.q.r. of 3.63.

There are no outliers and the standard deviation for this data set is $\sigma = 2.9$ with a mean of $\bar{x} = 13.03$. The data is within the mean $\pm 2SD$.

The data shows that the transition from the initial countersteer along L1 to maximum lean at L2 is much more compact than in the novice group. There is only one rider, rider 7 who leans to the right more dramatically than any other. This rider was identified earlier as the rider who initiated the turn with a lean to the right and gently increased that lean to the maximum at L2. The two riders that record the greatest lean angle at L2 are riders 7 and 10 one leaning the bike immediately left the other to the right figure 57.

Figure 57 Lean angles experienced riders 7 & 10

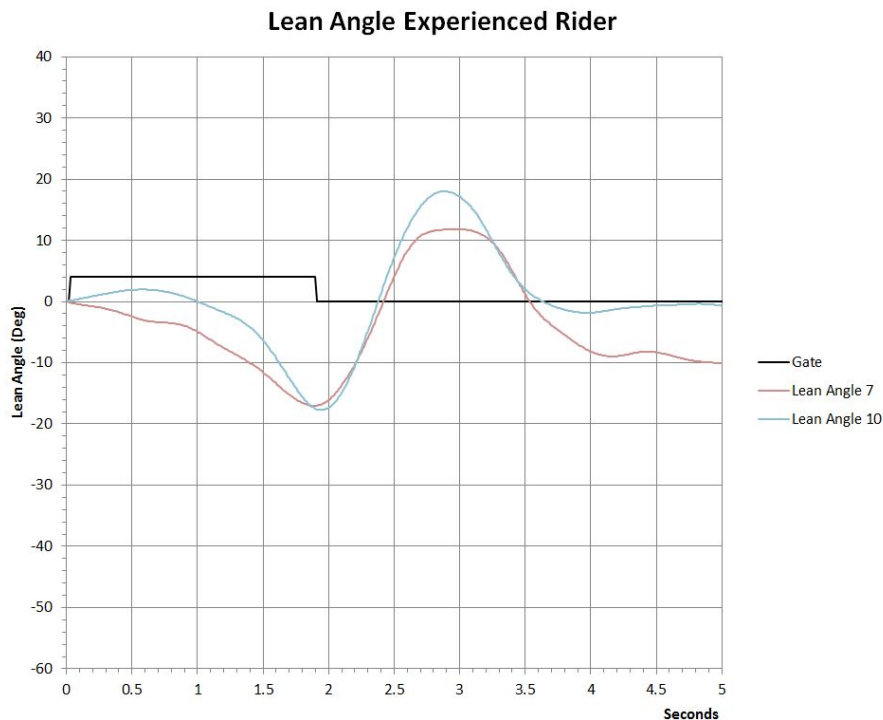

6.3.3.2 Phase 2 The lean angle during the transition and recovery

It was observed in the novice group that a typical rider passing the cone is seated approximately in line with the motorcycle. In this group a typical rider can be seen to have his torso and head at a totally different angle to the machine.

The motorcycle is at approximately 20° from the vertical and the rider is at about 4° from the vertical making the angle between the motorcycle and rider 164° . The mean angle from the data set is 15.54° but the maximum calculated from recorded data is 19.67° . A five-figure summary of the angles at L4 is

(11.84, 13.92, 15.78, 16.22, 19.67) with an i.q.r. of 2.3

There are no potential outliers and the data fits well within the mean $\pm 2SD$. The standard deviation for this data set is $\sigma = 2.9$ with a mean of $\bar{x} = 15.54$

Additionally the distance from the cone to the motorcycle is greater.

Figure 58 Experienced rider passing the avoidance cone

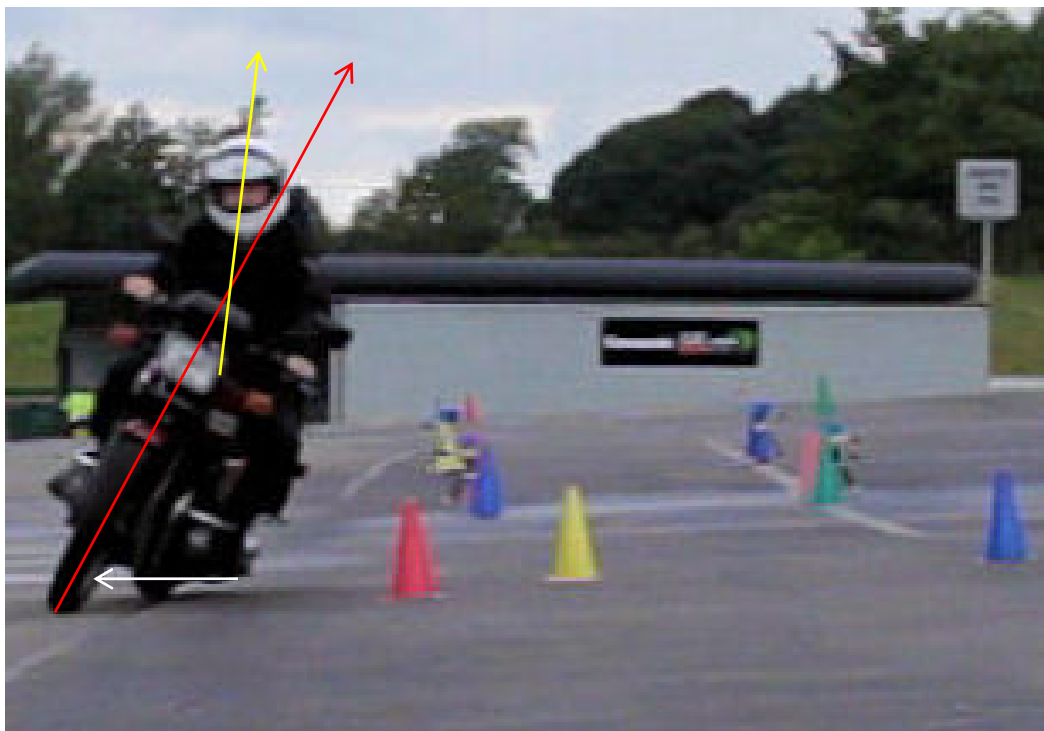

The longitudinal angle of the front wheel is such that the inner wheel rim is clearly visible. The white arrow in figure 58 indicates the visible section of the wheel rim indicating that the rider has not yet started to steer back onto the original course.

Between L2 through L3 to L4 the traces are again much more compact than for the novice group suggesting the riders have more overall control of the

motorcycle during the manoeuvre. A five-figure summary of the time between L2 and L4 is

(0.9, 0.93, 1.03, 1.1, 1.22) with an i.q.r. of 0.17

There are no potential outliers and the data fits within the mean $\pm 2SD$. The standard deviation for this data set is $\sigma = 0.10$ with a mean of $\bar{x} = 1.03$

6.3.4 Yaw angle

As stated at paragraph 6.1.4 the yaw angle is determined by how quickly the rider applies the initial torque to the handlebars and the steering angle achieved. Overall as expected this group being more experienced in handling a motorcycle produce a much 'tighter' graph (figure 59) than the novice group with all the riders again following a generally positive trace for about the first 1.5 seconds. After 1.5 seconds the trace is generally negative (clockwise yaw) before changing direction and levelling out to the end of the manoeuvre.

Figure 59 Yaw angles experienced riders

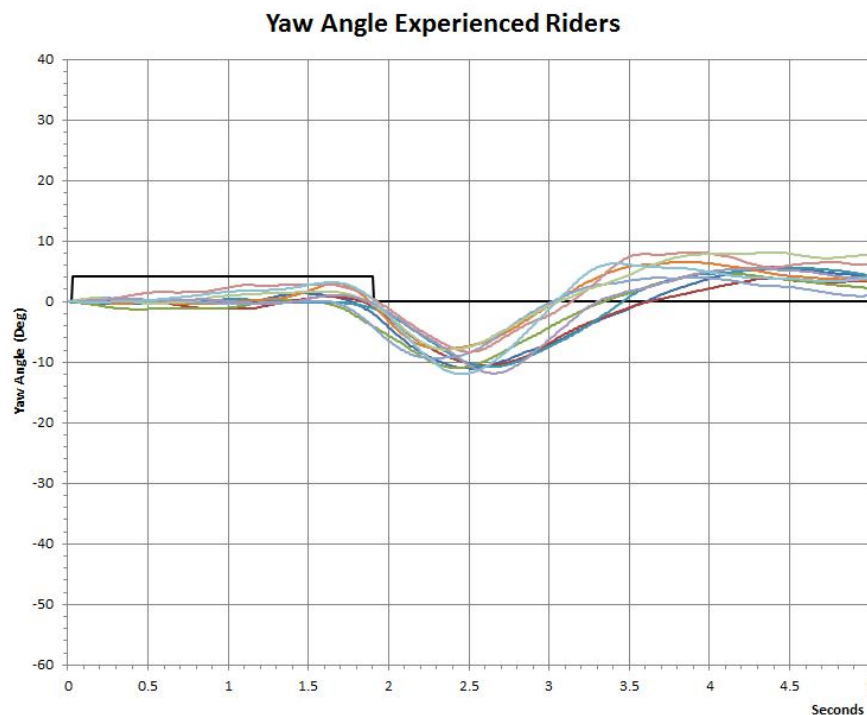

Table 14 shows the collected data in respect of the yaw angles and timings. Riders 1, 2, 3, 5 & 9 all maintain a relatively neutral yaw angle before moving counter clockwise (left) at the point where the swerve is initiated Y1. The mean degree of yaw for the initiation is approximately 1.5° compared the novice group of 2° . This may be as a consequence of how the riders change their body position in relation the motorcycle. A five-figure summary of the data is

(0.13, 0.32, 1.22, 2.89, 3.16) with an i.q.r. of 2.57

There are no potential outliers and the data fits well within mean $\pm 1\frac{1}{2}SD$. The standard deviation for this data set is $\sigma = 1.17$ with a mean of $\bar{x} = 1.47$

Three riders, riders 7, 8 & 10 start to yaw early and maintain a smooth increase in the yaw rate to the left (positive yaw) which identifies the initiation (figure 60). Although there are slight changes in the yaw rate there are no definite increases which identify where the countersteer is initiated.

Figure 60 Yaw angles experienced riders 7, 8 & 10

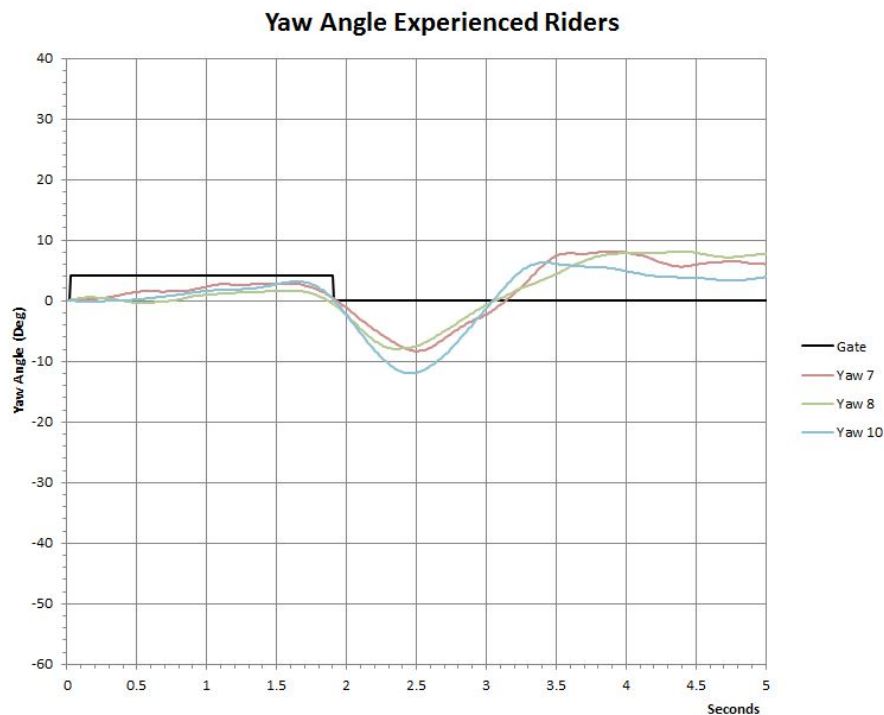

Riders 4 and 6 however maintain a steady neutral yaw throughout the initiation and there is no identifiable positive yaw. The manner in which the individual riders applied the torque at initiation was different. There are no obvious parallels between the two riders; rider 4 applied the torque firmly whereas rider 6 appeared to apply force to the right immediately prior to the countersteer.

Figure 61 Yaw angles experienced riders 4 & 6

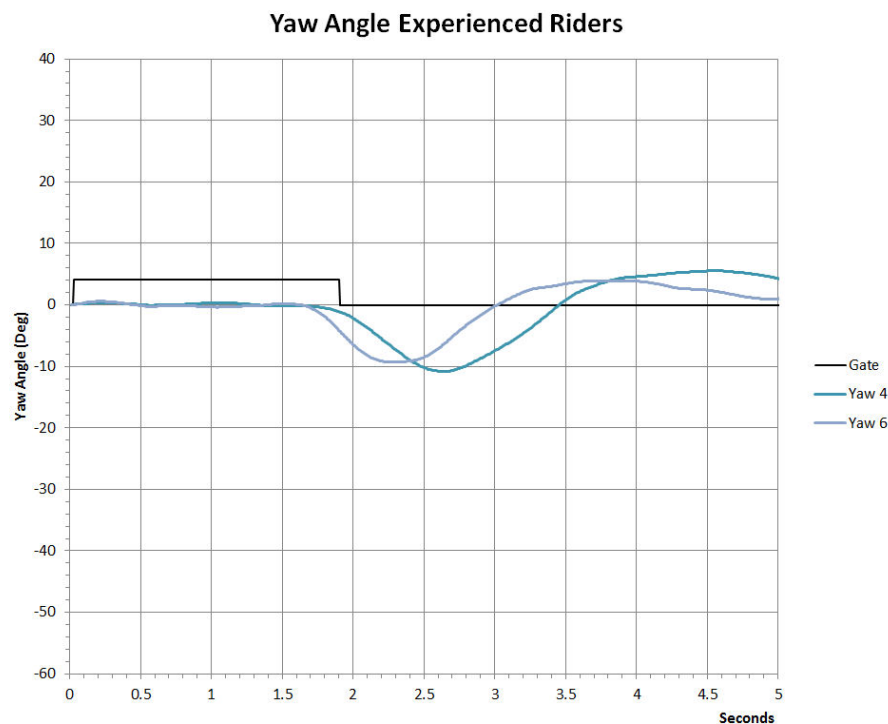

The yaw values at Y1 for the remainder of the group are all consistent with the motorcycle turning being steered to the left at initiation. Although there are differences prior to reaching Y1 the range of values at Y2 is between 7.94° and 11.96° with a mean of 10.05°. The mean value is some 7% less than the novice group. A five-figure summary of this data is

(7.84, 8.22, 10.65, 11.24, 11.96) with an i.q.r. of 3.02

The standard deviation for this data set $\sigma = 1.6$ and the mean $\bar{x} = 10.05$ show that all the data falls within the mean $\pm 2SD$.

6.3.5 Observations experienced rider group

Comparing the ability of this group to the novice group, it is apparent that the novice group achieved a 11.76% greater mean lean angle at L2. However this is reversed at L4 where the experienced group achieved a 10.78% greater mean lean angle.

This group appears to be inconsistent in their approach to the swerve manoeuvre. It is noted at T1 the force applied is less than the novice group but at T3 it is greater. The countersteer angle is also less than the novice group.

The time taken to achieve peak countersteer is 14% slower than the novice group, this follows from the peak torque at T1 being $\approx 17\%$ less than the Novice group. Although the manoeuvre appears smoother the experienced rider's lean angle is $\approx 1.5^\circ$ less than the Novice.

There is only a 10% difference between the mean times taken between T1 to T3 and S1 to S3. If the interval Y1 to Y2 is included the range this range is reduced to only 0.26 seconds

Riders have not started to steer back as they pass the cone

The riders in this group lean the motorcycle more as they pass the cone than the riders in any other group but the rider angle is not in line with the motorcycle.

6.4 Group 3 The Advanced Riders

Figure 62 gives a visual representation of the manoeuvre being undertaken by an advanced rider from a head-on viewpoint.

Figure 62 Visual representation advanced rider

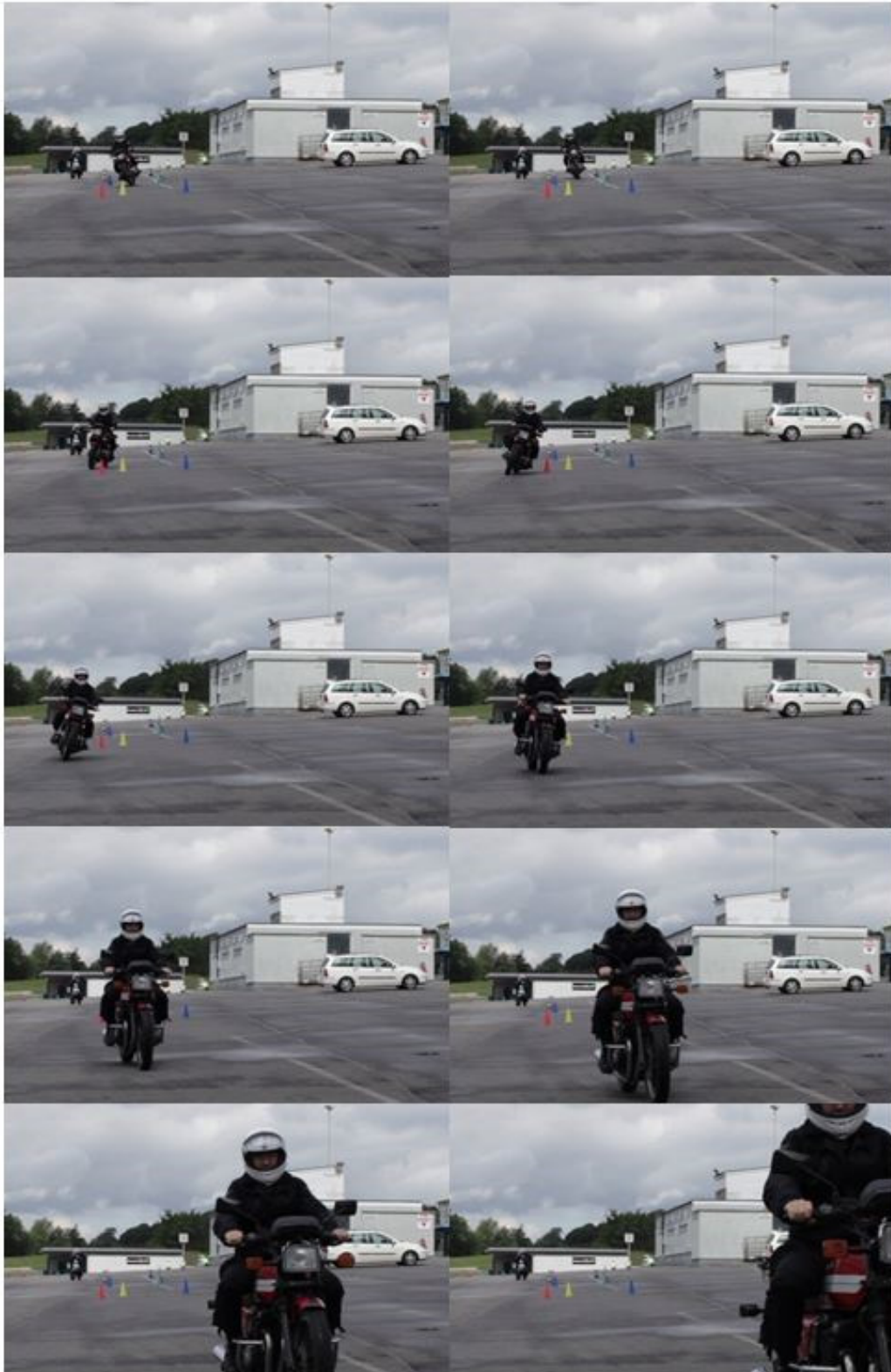

As previously stated the course to be manoeuvred is exactly the same for all groups within this research. Comparing figure 62 to both figures 28 and 48 the novice and experienced groups respectively there are clearly identifiable differences in the position and attitude of the motorcycle at various stages during the execution. There are also significant differences in the attitude (alignment of rider to the motorcycle) of the rider especially as the motorcycle passes the avoidance cone.

As with the previous groups 10 tests have been selected for analysis, each of which was ridden by an advanced rider with a full UK motorcycle licence. It is again possible that within this group there are riders who obtained their motorcycle license prior to the introduction of the new DOT 'off road' assessment. It is possible that some of the riders may not have seen or attempted this manoeuvre prior to evaluation. This particular group consisted of either advanced police riders, individuals who are either trained for VIP escort of high speed convoy riding or motorcycle instructors either in the private or public sectors. Consideration has been given to excluding the instructors as it is feasible these riders may teach the manoeuvre and demonstrate it during their daily activity. However, as identified within chapter 4 there is uncertainty as to the quality of counter steering training and therefore these riders have been included.

6.4.1 Torque

6.4.1.1 Phase 1 The initiation of the swerve

The initiation of the countersteer is the first input of force into the steering that the rider must do prior to the swerve manoeuvre. It was expected that there would be a significant increase of steering torque by this group due to experience and additional training. Figure 63 shows the torque inputs by the individual riders in the advanced group. The mean force at T1 was 20.74Nm a

significant increase of 45% over the experienced group but only 23% greater than the novice group. A five-figure summary is:

(16.54, 17.66, 19.39, 23.09, 29.35) with an i.q.r. of 5.43

This gives a range of 12.23 to 28.52 with a potential outlier at 29.35.

However the standard deviation for this data set is $\sigma = 3.9$ with a mean of $\bar{x} = 20.74$ which shows that all the data including the potential outlier is within $\pm 2.5SD$ of the mean. The median and mean are slightly offset, which confirms that the test sample is skewed.

Figure 63 Torque input advanced rider group

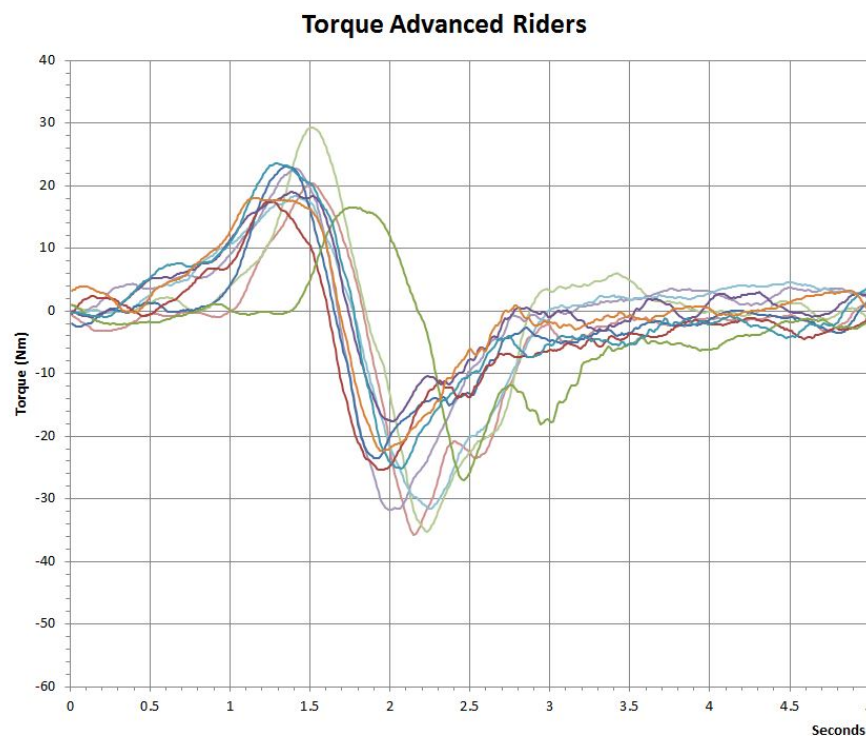

This advanced group can be placed into two categories, those who immediately start to apply the steering force and those who delay the application. Riders 1, 2, 5 & 7 delay the application of force and then apply it in a very short time, whilst the remainder apply it gradually over a greater period. Removing these four riders from the group they can be plotted as a sub group see figure 64.

Figure 64 Torque input advanced riders 1, 2, 5 & 7

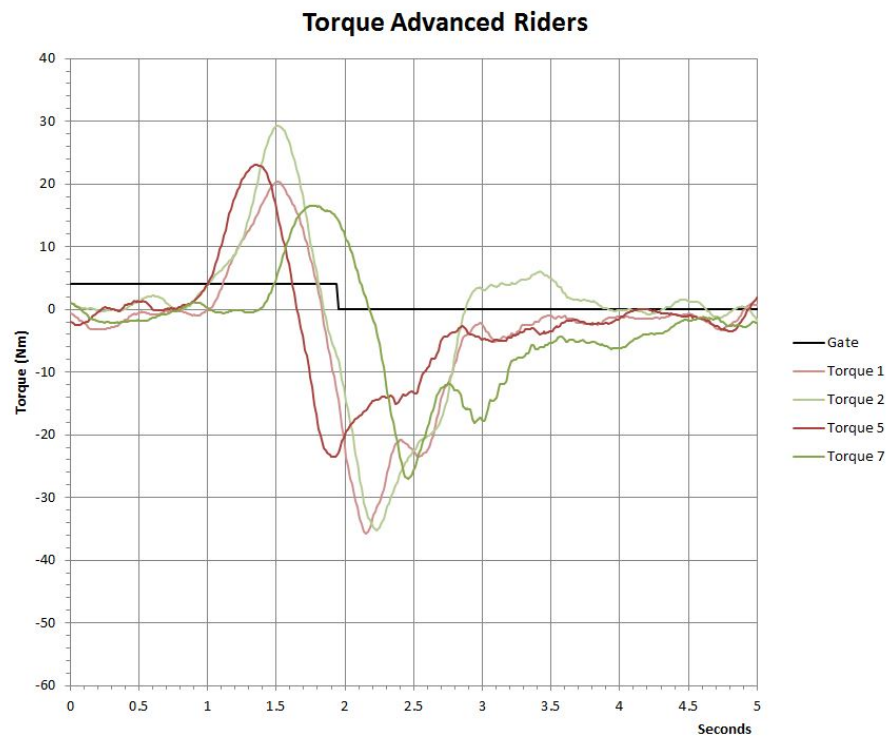

Clearly these four riders are waiting to apply the torque but when analyses they apply on average 13% greater force than the remainder.

The corresponding data for T1 is the time taken to reach the maximum torque at T1 (Table 15 column 2). It was expected that the time taken to apply the initial torque would diminish with experience and practice i.e. the speed at which the steering is applied in this particular scenario would increase. The initial steering force applied by this advanced group has clearly increased by a significant amount. It was expected that the corresponding time would decrease; it has in fact, increased. In fact the time from initiation to T1 is 10% greater than the experienced group and surprisingly 1.55% greater than the novice group. An explanation for this may be that the advanced rider subconsciously recognises the need to start the steering application earlier. This may be a consequence of conditioning especially if the rider has been exposed to this manoeuvre in the past.

The mean time for each of the sub groups identified to reach T1 is reached in 0.57 seconds for the four riders and 1.03 seconds for the remainder. Comparing these results with the novice and experienced groups does identify a possible trend; if the application time is decreased the force is increased. It is the ability of the rider to accurately and positively apply the force that is paramount in successfully making a 'swerve to avoid' manoeuvre.

Again taking the transition from T1 to T3 as a single entity, the time taken from the initial countersteer at zero was between 1.14 and 1.9 seconds with a mean of 1.51 seconds (Table 15 column 4). It was expected that the time from zero, the start of the steering action to T1, the peak torque, would again reduce as identified with the experienced group. This did not occur and there was an increase of 1.4% and 10.5% over the novice and experienced groups respectively. The mean time for this group was 0.85 seconds.

The transition time from T1 to T3 was 0.67 second, this is a reduction of 21% and 8.8% for the same interval when compared to the novice and experienced groups respectively. This particular group has taken longer to achieve T1, the maximum torque at countersteer but the time interval from T1 to T3 has reduced. Not only has the time interval reduced but the maximum force applied to the steering at T3 has also increased to a mean of 27.55Nm. This is an increase of 50% and 87% when compared to the experienced and novice groups respectively.

6.4.1.2 Phase 2 The torque forces during the transition and recovery

The advanced riders during the recovery phase reduce the force applied to the steering earlier than the experienced group. Comparison of the overall torque traces, figures 49 & 63 shows that the gradient of the traces from T3 to neutral is much steeper for the advanced group indicating that the riders are reducing the steering force more quickly than their experienced counterparts.

It was identified within the experienced group that one rider applied positive torque during the recovery, figure 53. Only one rider within the advanced group, rider 2, applied clear positive torque immediately after T3. This was not as high as the rider in the experienced group and was held for approximately 0.5 second figure 65.

Figure 65 Positive torque during the recovery, advanced rider 2

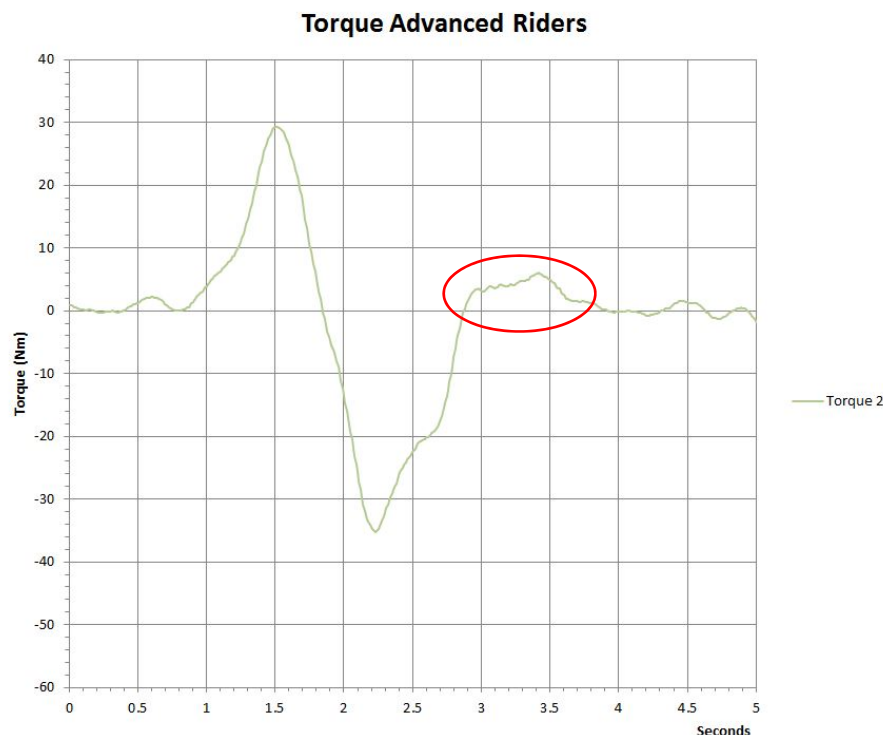

6.4.2 Steering angle

6.4.2.1 Phase 1 The initiation of the swerve

The most noticeable difference between the novice and the expert groups was the overall smoothness of the expert graph. The most noticeable difference between the advanced and expert group is the noise during the approach to the swerve and the recovery after the manoeuvre. The manoeuvre requires the riders to approach along a corridor some 1.5 metres wide at 30mph (13.41ms^{-1}). This aspect was discussed during chapter 5 and the inability of the novice riders dictated that this corridor could not safely be reduced in width. The advanced riders clearly maintain better control of the motorcycle in these more demanding

scenarios and hence on the approach there are less steering inputs to generate excessive noise. Figure 66 shows the steering inputs for the advanced group.

Figure 66 Steering inputs advanced group

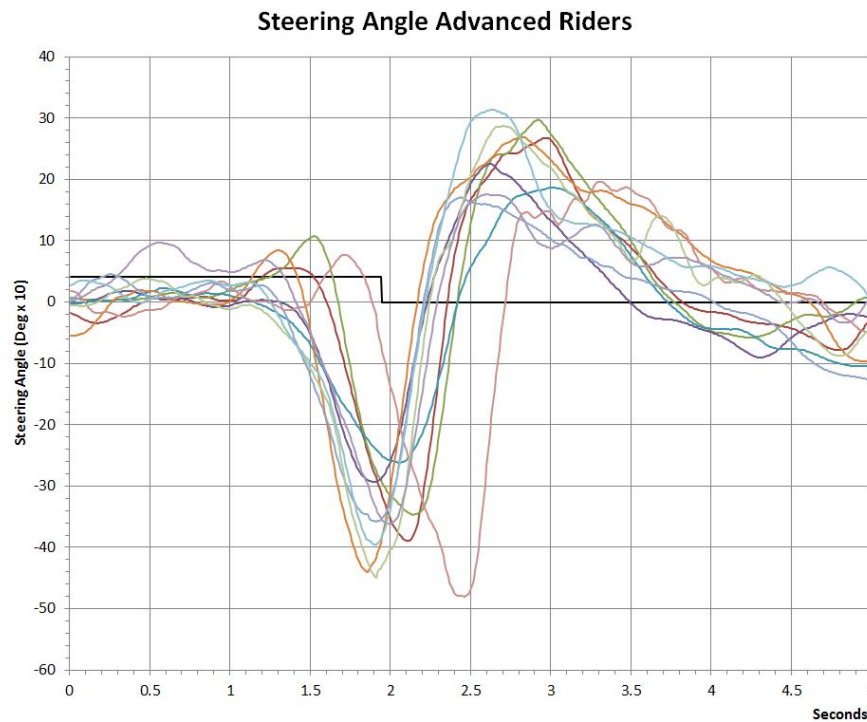

As expected the time to reach the maximum countersteer varied from rider to rider. Examination of the data revealed that the time taken from the initiation of torque to S1, the maximum countersteer angle, range from 0.16 to 0.72 seconds with a mean of 0.357 seconds.

The five-figure summary is:-

(0.16, 0.23, 0.3, 0.48, 0.72) with an i.q.r. of 0.25

The standard deviation for this data set is $\sigma = 0.18$ with a mean $\bar{x} = 0.36$. The data is slightly skewed but it is within the mean $\pm 2SD$. The mean time to S1 is a reduction of 32% compared to the experienced group.

The steering angle achieved during the countersteer ranged from 0.23° to 1.07°.

The five-figure summary is:-

(0.18, 0.29, 0.37, 0.88, 1.07) with an i.q.r. of 0.58

The standard deviation for this data set is $\sigma = 0.33$ with a mean $\bar{x} = 0.54$. The data set is clearly skewed when comparing the mean and median yet the data fits within the mean $\pm 2SD$. The mean countersteer angle is 14% less than the experienced group. The advanced group consists theoretically of 'better trained' and more experienced riders. The riders reach the maximum initial countersteer much quicker than the experienced group but apply a smaller steering angle to initiate the swerve. This suggests that it takes longer to apply a greater steering angle even when applying a greater force to the steering.

It has already been identified that the riders in this group applied the torque to the handlebars in two distinct ways suggesting that there would potentially be at least two steering categories. Analysis shows that there are three categories in the advanced group. The first two are the same as for the experienced group but a new category was identified where the rider initially steer left, then holds what appears to be neutral steer before steering right towards S3. None of the riders in this advanced group fell into category three as identified for the experienced riders.

The categories for this group are therefore:-

- held steady neutral, then steered left to maximum
- steered left, held neutral, then steered right
- gentle steering to the left with adjustments

The first category consists of four riders, riders 1, 2, 5 & 7 who all held steady neutral and then steered right. The same group of riders were also identified in the previous section by the manner in which they applied the force to the steering. An identified difference in this sub-group was the duration of time the maximum steer was held for. Rider 7 who was previously identified as the rider who was last applying the torque also held the maximum countersteer longest. Figure 67 shows this category of rider. The greatest countersteer angle at S1 within this group was 1.07 degrees.

Figure 67 Steering input advanced riders 1, 2, 5 & 7

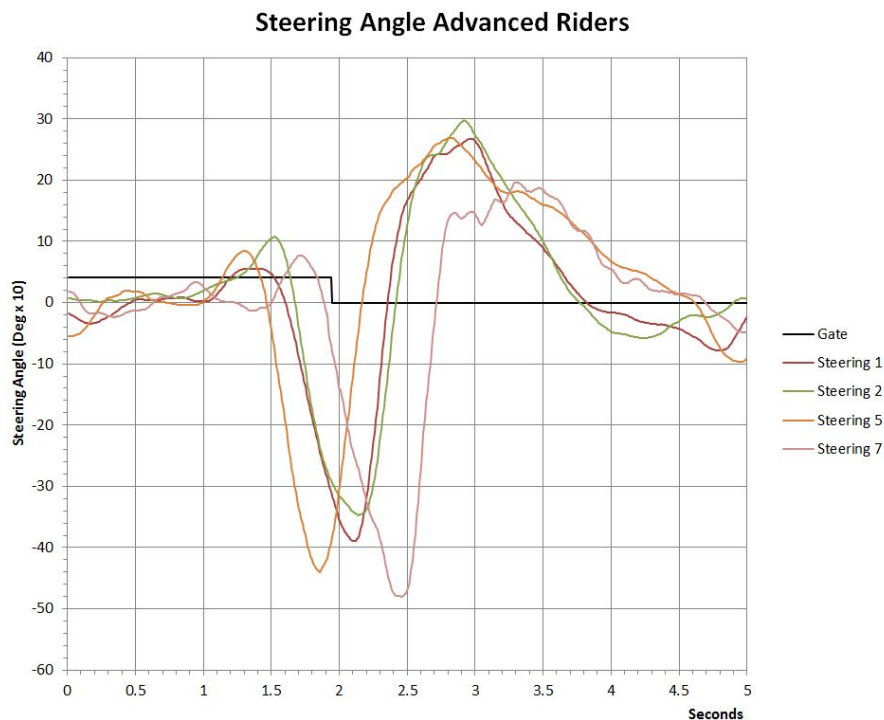

Although the riders applied the steering at different times the transition from S1 to S3 are all very uniform with similar gradients to the traces.

Riders 3, 4 & 8 make up the second category, these riders initiated the countersteer by initially steering to the left but then appear to hold steady neutral before steering to the right towards S3. The largest angle at S1, for these three

riders was 0.39° which is substantially smaller when compared to the other two categories.

Figure 68 Steering input advanced riders 3, 4 & 8

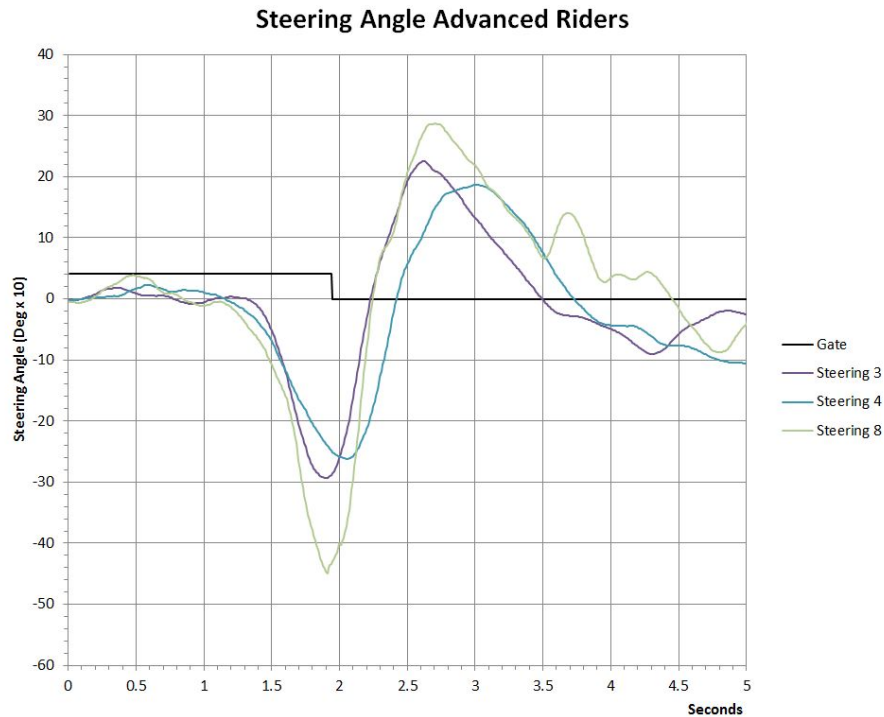

The transition from S1 to S3 for this sub-group is not uniform with one trace, the trace for rider 8 having a greater slope than the other two. Within this sub-group rider 8 applied substantially less torque than the other two riders.

The final category, category 3 are riders 6, 9 & 10, these riders applied steering to the left but made corrections / adjustments during the initial countersteer.

The maximum countersteer angle was 0.97° . Figure 69 shows this category.

Figure 69 Steering input advanced riders

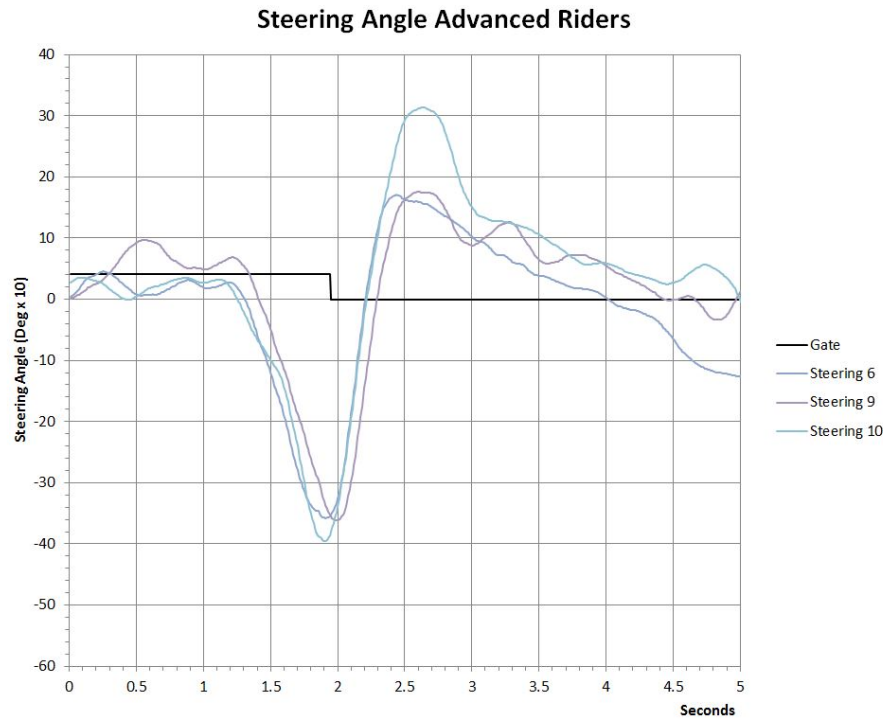

Although there are slight differences in the initial countersteering application it could be argued that these three riders were most consistent in their steering during the manoeuvre. The traces are extremely similar with the riders appearing to perceive and react to the manoeuvre at similar times. The transitions from S1 to S3 are close to being coincidental.

The transition from S1 through neutral (S2) and on to S3 the maximum steering angle to avoid the cone is much tighter than either the novice or experienced groups. The steering angles at S3 ranged from 2.62° to 4.79° gives a five-figure summary of:-

(2.62, 3.33, 3.78, 4.43, 4.79) with an i.q.r. of 1.10.

There are no potential outliers and the whole data set fits well within the mean $\pm 2SD$. The standard deviation for this data set is $\sigma = 0.69$ with a mean of $\bar{x} = 3.78$. As stated previously it is expected that the time interval from S1 to S3

should be similar to the time interval between T1 and T3. In this particular group there is a 60% difference. It has been identified that riders 3,4 & 8, the riders in the second category, initially steered left, held neutral, then steered right, thus increasing the time interval between the peaks. Removing the times taken for these riders from the analysis the mean time between S1 and S3 is reduced to 0.88 seconds and the percentage difference is reduced to 32%.

6.4.2.2 Phase 2 The steering angles during the transition and recovery

During the recovery phase the rider steers from the maximum at S3 to neutral steer at S4. In order to complete the manoeuvre the rider must then steer to the left in order to miss the second offset cone and stop within the final gate. As has been previously discussed, once the rider is past the avoidance cone there is no pressure on the rider to steer quickly. For analytical purposes the time interval between S3 to S4 is observed. A five-figure summary for this group (Table 16 column 7) provides:-

(0.53, 0.69, 0.76, 0.89, 0.97) with an i.q.r. of 0.2

The standard deviation for this data set is $\sigma = 0.14$ with a mean of $\bar{x} = 0.77$ all the data is within the mean $\pm 2SD$. The mean time is surprisingly 203% that of the novice group mean and 179% of the experienced group mean. This increase supports the hypothesis that the more competent the rider, the greater their perception of time and distance.

The overall time to complete the manoeuvre can also be calculated. This time interval may give an indication as to the precision of the rider's steering i.e. the ability of a rider to recognise the available distance in which a manoeuvre has to be completed and to steer accordingly. This aspect of the rider perception is not considered within the scope of this research.

6.4.3 Lean angle

6.4.3.1 Phase 1 The initiation of the swerve

The plot of lean angles achieved by this advanced group has provided a more compact set of traces. Clearly there is one trace which does not follow the majority and that is rider 7 who has been identified throughout this analysis. Although this particular trace is detached it is consistent with the remainder.

Figure 70 The advanced group lean angles

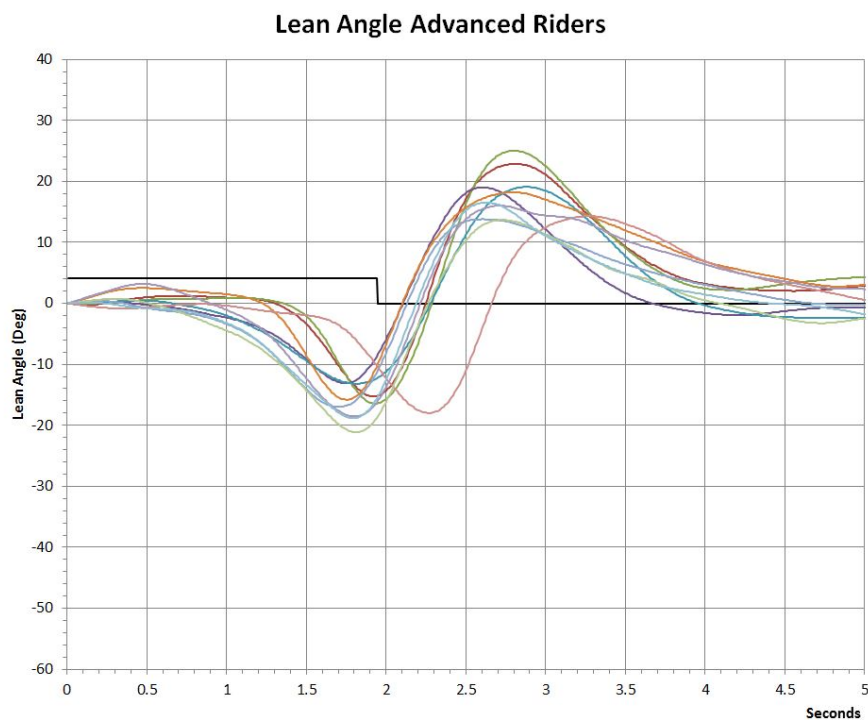
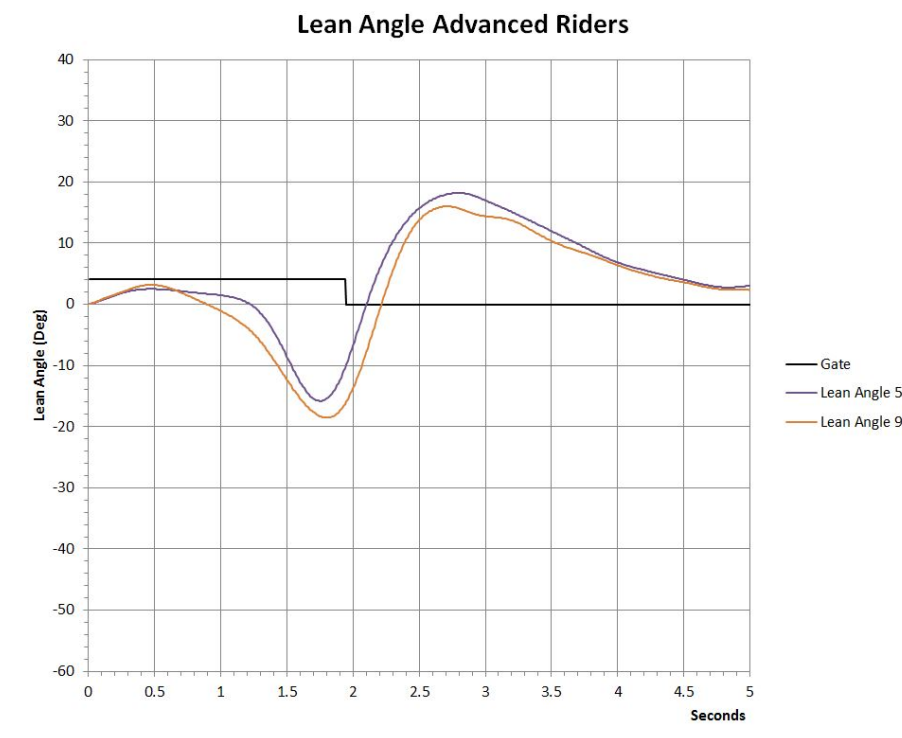

Table 17 columns 2 and 3 identify that five of the riders leaned to the left at the initiation of the swerve as expected. Two of these riders, riders 1 and 5 actually started to lean prior to any recognisable force being applied to the handlebars. Four riders, riders 1, 2, 5, 8 & 9 either lean immediate to the left for a short time or lean immediate left for a longer period. The magnitude of this lean is approximately 50% greater for the 'short term' lean. Riders 5 & 9 leaned left for the short interval, they both applied forces in the upper quartile at T1 and steering angles at S1 which were also in the upper quartile.

The respective traces are shown at figures 71 and 72.

Figure 71 Advanced riders 5 & 9 lean angles



Riders 1 & 2 do not follow such a simple analysis, rider 1 only applies a mean force at T1 and a steering angle at S1 in the lower quartile. Rider 2 however applies the greatest force at T1 and the greatest steering angle at S1.

Rider 8 also leaned to the left, this rider applied a force in the lower quartile at T1 and a steering angle at S1 which was only 0.2° above the mean. The trace of this rider does not however fit with the other four riders.

Figure 72 Advanced riders 1 & 2 lean angles

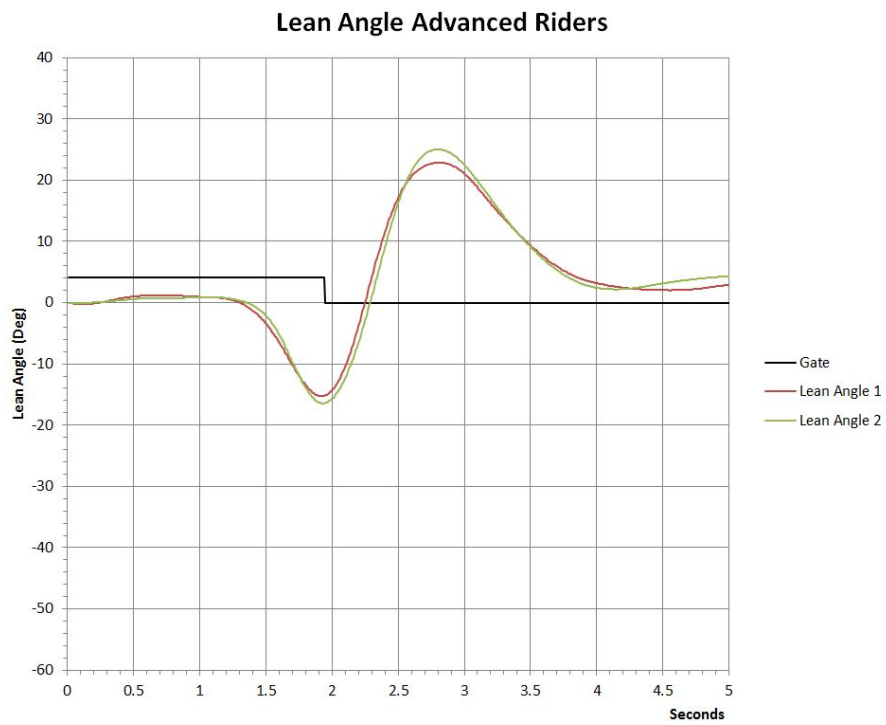
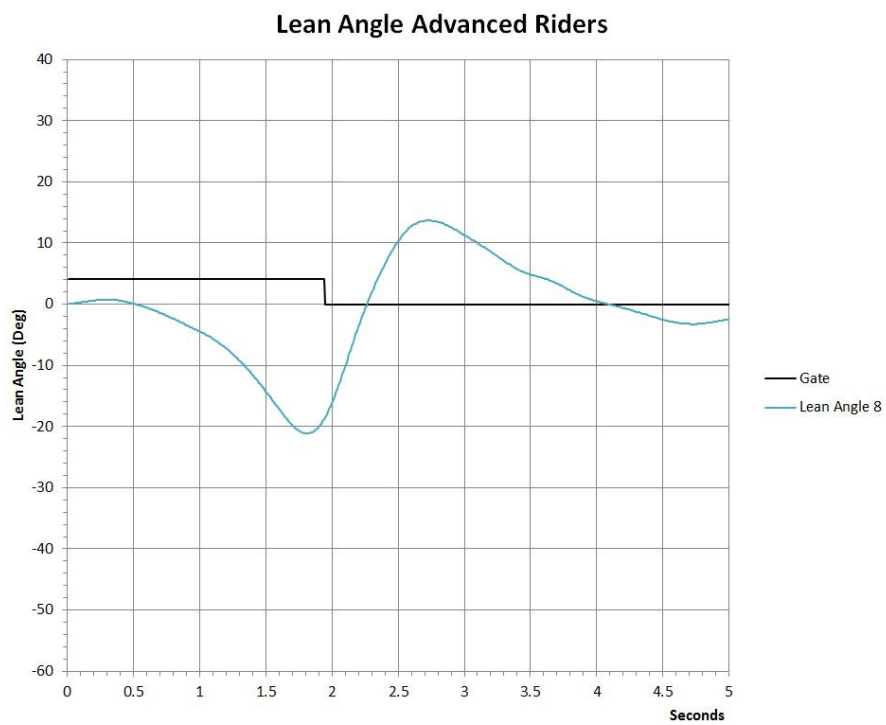

Figure 73 Advanced rider 8 lean angle



The remaining riders, riders 3, 4, 6, 7 & 10 do not make any appreciable lean to the left at the initiation of the swerve. The traces of the rider's lean angles do follow a very similar path. It is possible that there is some positive lean (lean to the left) at the early stage of the manoeuvre however due to the method of calculation this may be as a consequence of noise. Noticeable for this sub-group is that the peak lean at L2 is closer to the gate, suggesting that these riders may have initiated the torque/steering at an earlier stage in the manoeuvre. Alternatively this may be due to the rider shifting their body on the motorcycle during the manoeuvre. The graph of these riders figure 74, is 'tight' with only the one previously identified rider being displaced.

Although rider 8 initially leaned to the left the trace of his lean angle best fits with the riders who did not appreciably lean in that direction.

Figure 74 Advanced riders 3, 4, 6, 7 & 10

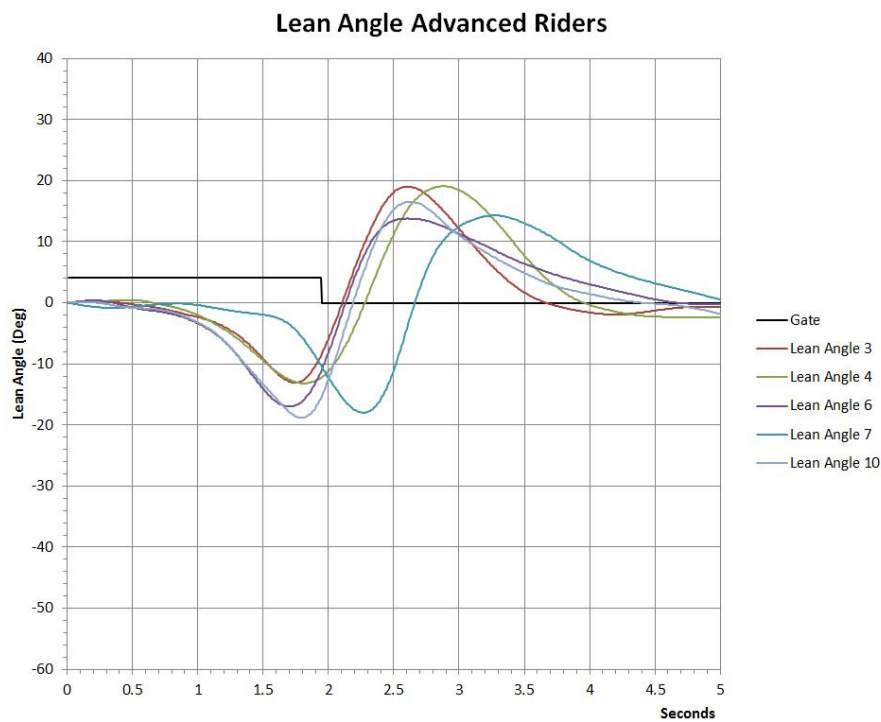

Statistical analysis of time taken to reach L2 and the maximum angle achieved at L2 show that the mean time was 1.26 seconds and that the mean angle was -16.72°. This is an increase in time of 6% and 28% respectively over the experienced group of riders. A five-figure summary for the time interval to L2 is:-

(0.89, 1.02, 1.26, 1.53, 1.64) with an i.q.r. of 0.50

There are no potential outliers and the standard deviation for this data set is $\sigma = 0.28$ with a mean of $\bar{x} = 1.26$. This data set is extremely well centred and fall within the mean $\pm 1\frac{1}{2}$ SD.

Similarly the maximum angles of lean achieved at L2 are:-

(13.09, 14.73, 16.72, 18.61, 21.14) with an i.q.r. of 3.88

There are no potential outliers and the standard deviation for this data set is $\sigma = 2.5$ with a mean of $\bar{x} = 16.72$. This data set is again extremely well centred and fall within the mean ± 2 SD.

6.4.3.2 Phase 2 The lean angle during the transition and recovery

The attitude of the motorcycle as it passes the avoidance cone gives an indication of the rider's ability to manoeuvre the motorcycle. The maximum angle recorded at L4 was 25°. The five-figure summary for the data is;

(13.66, 14.17, 17.36, 20.02, 25.02) with an i.q.r. of 5.85

There are no potential outliers and the standard deviation for this data set is $\sigma = 3.8$ with a mean of $\bar{x} = 17.85$. The mean and median are well centred and the data fits within the mean ± 2 SD.

Figure 75 shows a typical advanced rider executing the manoeuvre and passing the avoidance cone, the angle of lean is 25° but the angle of the rider is approximately 6° from the vertical, hence an angle of approximately 161° between bike and rider.

Figure 75 Advanced rider passing the avoidance cone



Comparing this rider to the experienced rider, there are similarities in relation to the attitude of the motorcycle and rider. This advanced rider has positioned the motorcycle much closer to the cone and this was evident for the entire group. The angle between the rider and motorcycle only changes by 3° , the experienced rider remaining more upright than the advanced rider who 'goes' with the machine.

There are however significant differences in relation to the longitudinal angle of the front wheel. In this particular case it is clear that the rider is already steering back to the original direction/course of travel. Comparing the front wheel angle of the experienced rider in figure 58, it is possible to see the nearside of the wheel rim indicating that the rider has not yet steered to the left. The front wheel of the advanced rider however is in such a position that the rim is not visible. The wheel is therefore in-line with the camera and the rider is steering to the left. This indicates that the advanced rider has initiated the steering to the left prior to reaching the avoidance cone. The overall effect of this is that the rider has

avoided the cone and is returning to the original direction of travel without transgressing any farther than is necessary to the right in order to pass the cone. When considering this as a road safety issue it is essential that the rider can recover from the swerve action quickly to avoid any conflict with oncoming vehicles.

However, overall the time interval between L2 and L4 decreased by 11% when compared to the previous group showing that the advanced rider is quicker to apply the steering required in avoiding the cone. Hence the rider is steering back to the original direction of travel earlier as can be seen in figure 73.

A five-figure summary of the time between L2 and L4 is:-

(0.83, 0.87, 0.91, 1.02, 1.07) with an i.q.r. of 0.16

There are no potential outliers and the standard deviation for this data set is $\sigma = 0.084$ with a mean of $\bar{x} = 0.93$. This data set is well centred and fall within the mean $\pm 2SD$.

6.4.4 Yaw angle

The yaw angle as previously stated has been calculated from the rate gyro situated at the rear of the test motorcycle. It was identified within the experienced group that there were differences in the dynamics of the motorcycle as the riders approached the gate. The graph showing this group as a whole, figure 76 does indicate that the riders tend to hold a more neutral yaw angle on the approach compared to the experienced riders where the trend was for a positive counter clockwise yaw. The yaw being consistent with the countersteer required to initiate the right swerve manoeuvre. This group appears evenly dispersed either side of neutral. The data set for the yaw angles as a group as a five-figure summary are;

(0.07, 0.39, 1.06, 1.86, 2.31) with an i.q.r. of 1.47

The standard deviation for this data set $\sigma = 0.77$ and the mean $\bar{x} = 1.17$ show that all the data falls within the mean $\pm 1.5SD$. The mean and median are offset and the i.q.r. is approximately twice the standard deviation but the data is within the mean $\pm 1.5SD$. Comparing this mean with the mean of the experienced group there is a substantial difference of 26%.

Figure 76 Yaw angles advanced riders

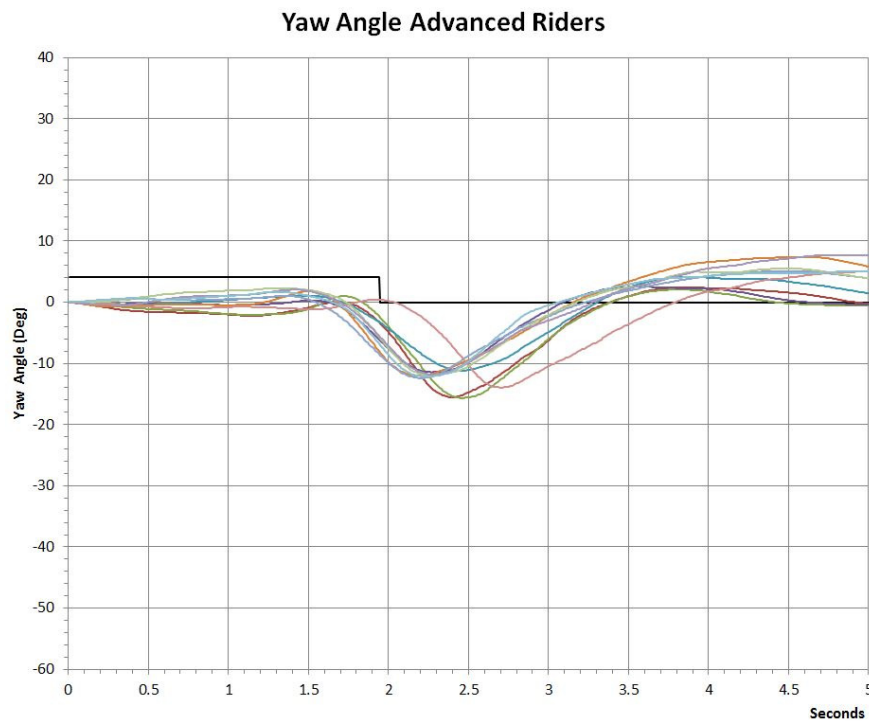

Examination does however separate the riders into sub-groups, those who maintain a steady neutral approach and yaw left immediately prior to the initiation of the swerve e.g. riders 3, 4 5 & 6.

Figure 77 Yaw angles advanced riders 3, 4, 5 & 6

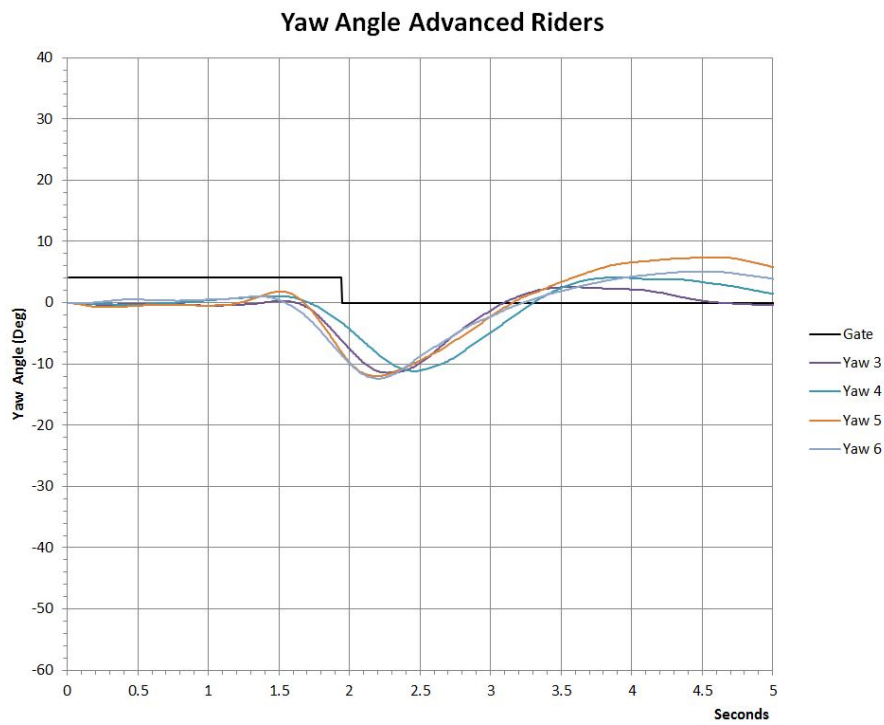

The traces of riders 8, 9 & 10 show a gradual build up to Y1 with little evidence of any yaw at the countersteer figure 78.

Figure 78 Yaw angles advanced riders 8, 9 & 10

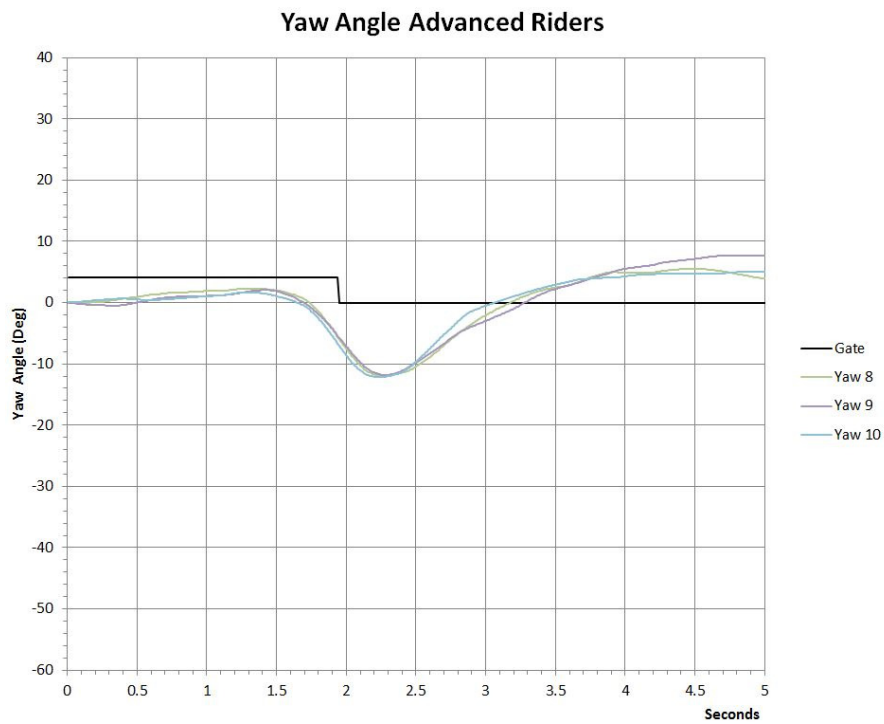

Riders 1, 2 & 7 however initially yaw clockwise, identified by the negative trace in figure 79 they do however show a clear Yaw at Y1 the point of countersteer.

Figure 79 Yaw angles advanced riders 1, 2 & 7

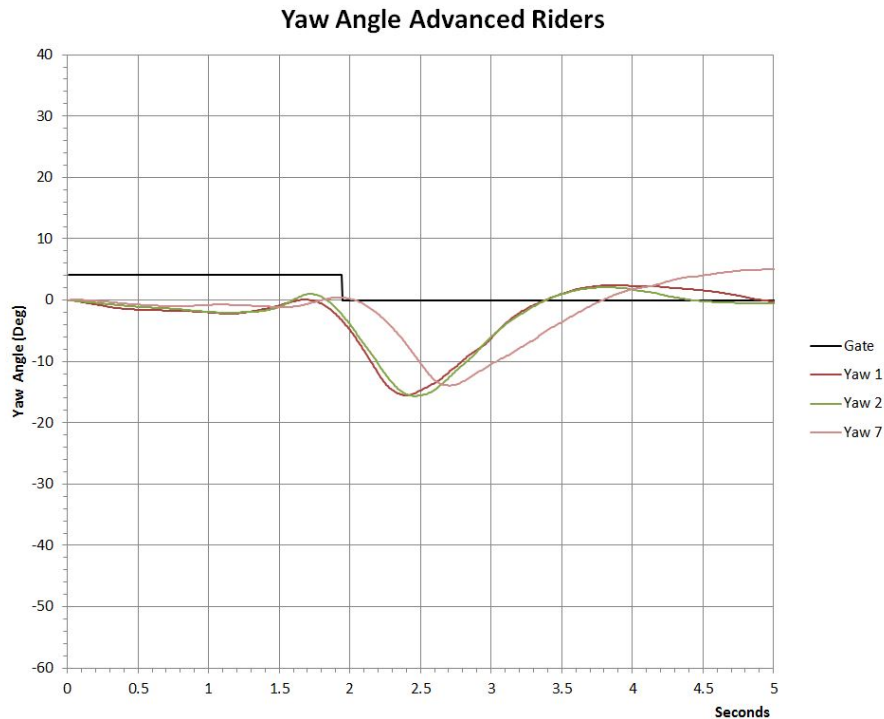

The magnitude of the yaw angle at Y2 where the motorcycle passes the avoidance cone and the time interval between Y1 and Y2 can be directly attributed to the force that is applied at T1 and T2. A five-figure summary of the time interval Y1 to Y2 is

(0.69, 0.74, 0.82, 0.93, 0.99) with an i.q.r. of 0.19

The standard deviation for this data set is $\sigma = 0.10$ with a mean of $\bar{x} = 0.82$ the data is very well centred and the i.q.r. and SD are close. The mean time interval is 0.16 seconds less than the experienced group a significant difference.

The angle achieved by the advanced group is significantly larger, a 27% increase. The five-figure summary is

(11.17, 11.73, 12.08, 14.34, 15.65) with an i.q.r. of 2.61

The standard deviation for this data set is $\sigma = 1.7$ with a mean of $\bar{x} = 12.80$. The mean and median are not exactly centralised and this is supported by the difference in the SD and i.q.r. the data is however within the mean $\pm 2SD$.

6.4.5 Observations advanced rider group

In all the ten cases the first peak in the trace was the maximum steer angle reached during the initiation of the turn.

Those riders who achieved the greatest steering at S3 applied the lower forces to the steering.

The intervals observed between T1 to T3 and S1 to S3 should be similar. i.e. the time between the peak forces should be similar to the time between peak steering. In this group there is a significant increase. The difference is 60% compared to 30% and 10% for the novice and experienced riders respectively.

Removing category 2, i.e. riders 3, 4 & 8 from the data reduces the mean and reduces the difference between T1-T3 and S1-S3.

The final recovery is not as ragged as the other two groups suggesting that these riders have a better appreciation of distance, time and steering precision.

The time between L2 and L4 identifies that the riders are steering back to the original direction of travel much earlier i.e. the time encroached in the opposing traffic lane would be reduced.

The time interval between S1 and S3 is abnormally large, very close to the novice group but it is 31% longer than the experienced group!

The range of time across all the intervals T1 – T3 etc is 0.236s, including the interval S1 to S3. Compared to the novice and experienced groups this is slightly shorter (0.023 seconds).

Riders have either reached neutral steer or are starting to steer back as they pass the cone.

The rider's body line is also more in line with the motorcycle during the swerve.

6.5 Group 4 The Expert Riders

Figure 80 below gives a representation of an advanced rider negotiating the course.

Figure 80 Visual representation expert rider

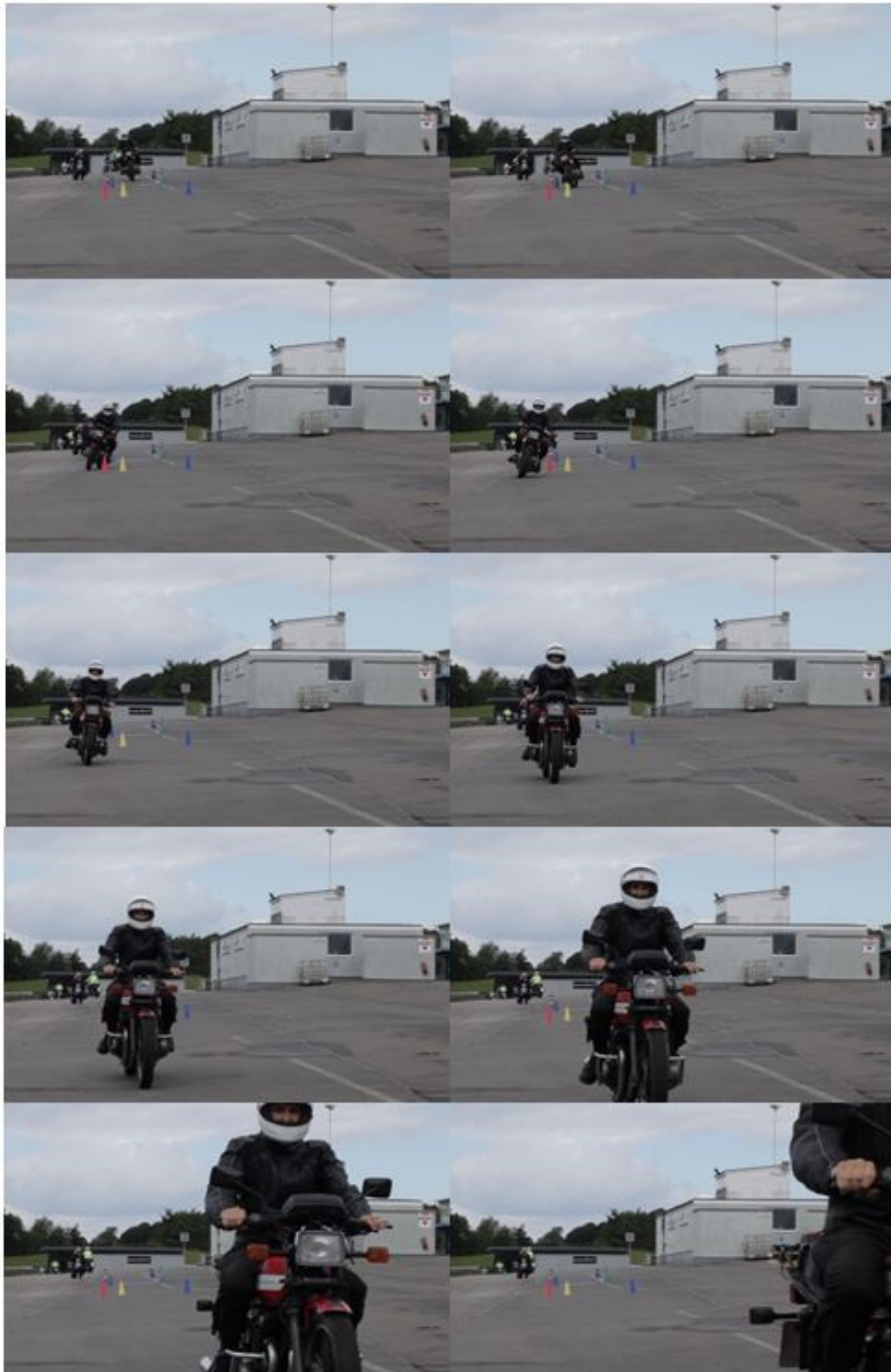

This group of expert riders are the last to be analysed. All of these riders have participated in some form of track racing and are all current instructors. The range of expertise covers individuals who are self-funding amateur racers to individuals who have been professional team racers. Due to the limited number of riders willing to participate and the constraints applied to the data for suitability to be included, only six riders have been selected. This category of rider is experienced in having to make quick decisions often due to the action of others whilst potentially travelling at high speed either on the race tracks or whilst on the public roads instructing police officers in protection duties.

6.5.1 Torque

6.5.1.1 Phase 1 The initiation of the swerve

The graph of the torque input by these riders is below, figure 81.

Figure 81 Torque input expert riders

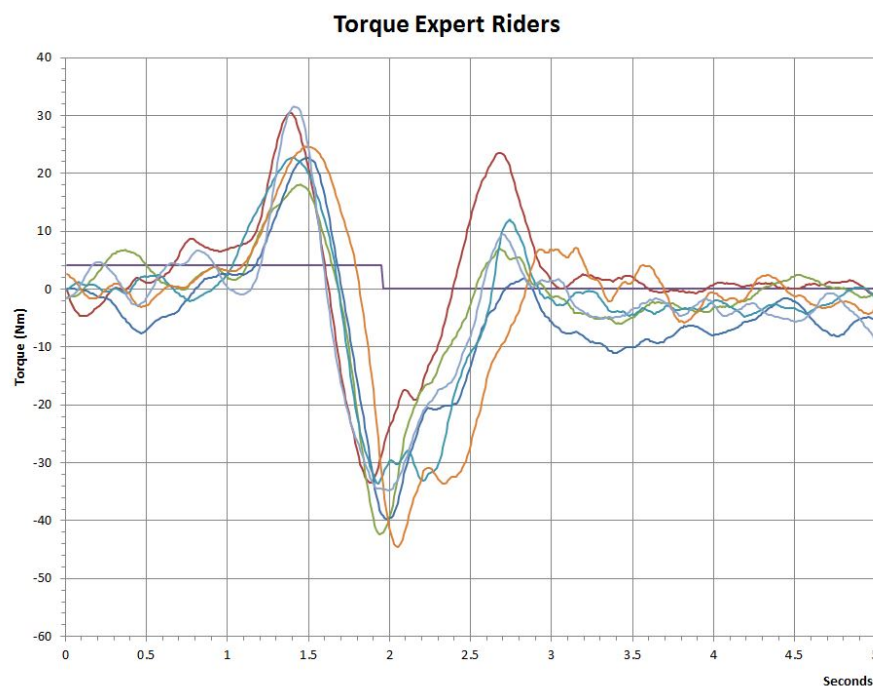

Overall the traces for this group are much more regular in appearance but there are clearly two traces which stand out from the rest. The two traces from rider 1 and 6 record the highest magnitude of torque at T1, i.e. peak countersteer

where the forces were 30.496Nm and 31.512Nm respectively. The individual traces show that both riders initiate the turn at the same time with similar force. The rate at which they change the direction of force from left to right (+ve to -ve) is very similar, the only difference being that rider 1 releases the force at T3 slightly earlier than rider 6. Figure 82 below identifies this difference at approximately 1.9 seconds.

Figure 82 Torque input expert riders 1 & 6

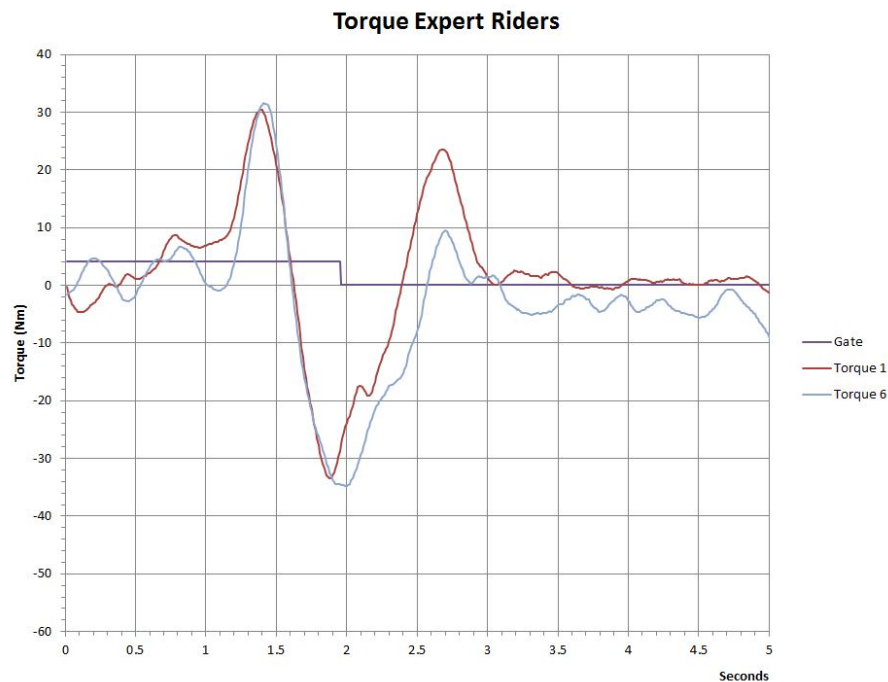

The comparison of these two riders with the remainder of the group identifies that there is very little difference between any of the riders in the initial application of the steering force required to initiate the turn. The more readily identifiable differences are at the recovery stage when the rider steers back to the original direction of travel, figure 81.

Figure 83 Torque input expert riders 2, 3, 4 & 5

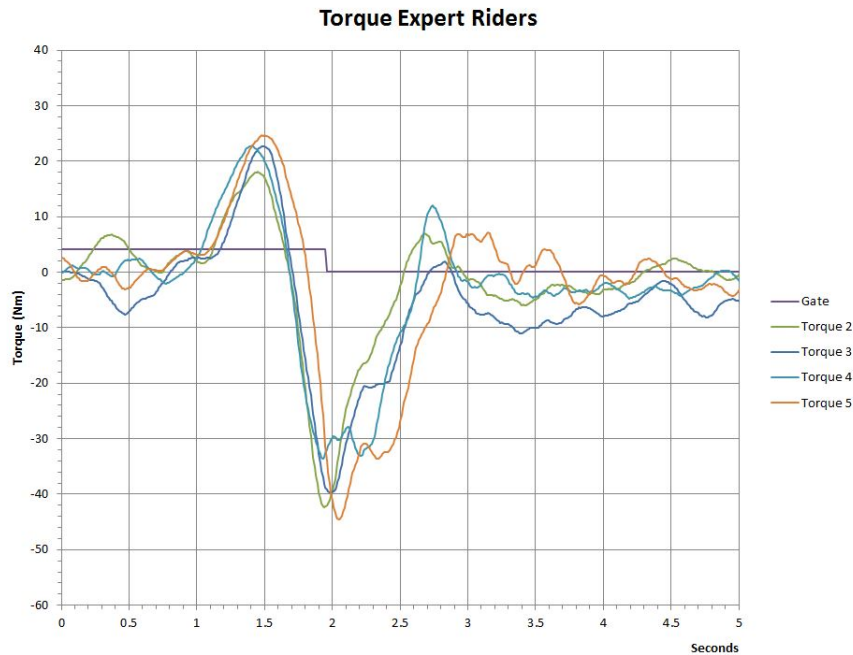

It was identified that the mean time for the advanced group to reach T1 was longer than the other groups. In this group there was a reduction of 24% when compared to the novice and advanced groups and a 12% reduction compared to the experienced group. A five-figure summary of the time to T1 reveals;

(0.27, 0.64, 0.70, 0.93, 1.02) with an i.q.r. of 0.29

There are no potential outliers and the standard deviation for this data set is $\sigma = 0.27$ with a mean of $\bar{x} = 0.68$. This data set is well centred and is within the mean $\pm 2SD$. There is very little difference between the mean and median values indicating that the data is extremely well centred. The forces at T1 range from 18Nm to 31.5Nm. This is comparable to the advanced groups where the range was 16.5Nm to 29.34Nm. The expert riders apply slightly higher forces at the initiation but the intervals at T1 and T3 are very similar; 13.5Nm and 12.8Nm respectively. Compared to the novice and experienced groups where the range is 15Nm and 21Nm respectively, it is the experienced group where the significant difference appears.

The five-figure summary for the forces applied at T1 in the expert group is;

(18.05, 21.54, 23.69, 30.75, 31.51) with an i.q.r. of 9.21

Although the data is not as well centred as that of the time to T1, there are no outliers and the data fits within the mean $\pm 1.5SD$ where the mean $\bar{x} = 25.02$.

There is a significant difference in the forces at T3, the peak steering to avoid the cone. The data set reveal the five-figure summary;

(33.12, 34.34, 38.93, 43.78, 44.50) with an i.q.r. of 9.438

The standard deviation for this data set is $\sigma = 5.0$ with a mean of $\bar{x} = 38.96$.

Again the data set is well centred about the mean and median suggesting that all the riders are steering in a similar manner. It is the force applied at T3 where the most significant difference lies between all the groups. This expert group apply a mean force of 38.96Nm some 11.42Nm or 41% more than any other group. It is this ability to apply such a large force into the steering system in a short time interval and to maintain control of the motorcycle that allows a rider to potentially avoid a sudden and unexpected obstacle.

The time interval between T1 and T3 as previously stated determines how quickly the rider can initiate the steering to avoid an obstacle. The five-figure summary of the time interval between T1 and T3 is;

(0.46, 0.47, 0.52, 0.64, 0.8) with an i.q.r. of 0.175

The standard deviation for this data set is $\sigma = 0.13$ with a mean of $\bar{x} = 0.56$.

The data fits well within the mean $\pm 2SD$ and the data is extremely well centred.

It is the mean time between T1 and T3 where the most significant difference appears to be within the riders groups. This expert group achieved a mean time of 0.56 seconds this is 50%, 30% and 19% quicker respectively than the novice, experienced or advanced groups. If this is put into context the expert rider has a

much greater chance of avoiding a perceived incident. The data appertaining to the torque in this expert group is found in table 19.

6.5.1.2 Phase 2 The torque forces during the transition and recovery

This group of riders clearly have the ability to exert higher forces into the steering and are capable of maintaining excellent control of the motorcycle. It follows that during the recovery phase the rate of steering force should be of a similar nature. It has been identified in the experienced and the advanced group that two riders did in fact apply positive torque during the recovery. All the riders in this group applied positive torque immediately after T3 to recover the motorcycle onto its original path. It is noted that the initial recovery is much more positive in nature suggesting that the riders are confident in what they are doing on the motorcycle. Instead of the recovery being a gentle slope from T3 towards neutral, these riders place the machine back on course quickly and travel in the region of 2 seconds with little or no steering input completing the manoeuvre.

6.5.2 Steering angle

6.5.2.1 Phase 1 The initiation of the swerve

Having identified the differences in the steering forces applied by the different riders at paragraph 6.5.1 above, it follows that there should be similar difference in the steering angles. This has not always been the case in the preceding groups. There is the potential that the greater force exerted by the rider is only being used to counter the 'righting' moments of the machine system, allowing the rider to make the turn without having to apply a large force into the steering.

Figure 84 shows the steering input by this particular group. Peak countersteer at S1 is at approximately 1.4 seconds and it can be seen from the graph that there are inconsistencies between the riders.

Figure 84 Steering angle input expert riders

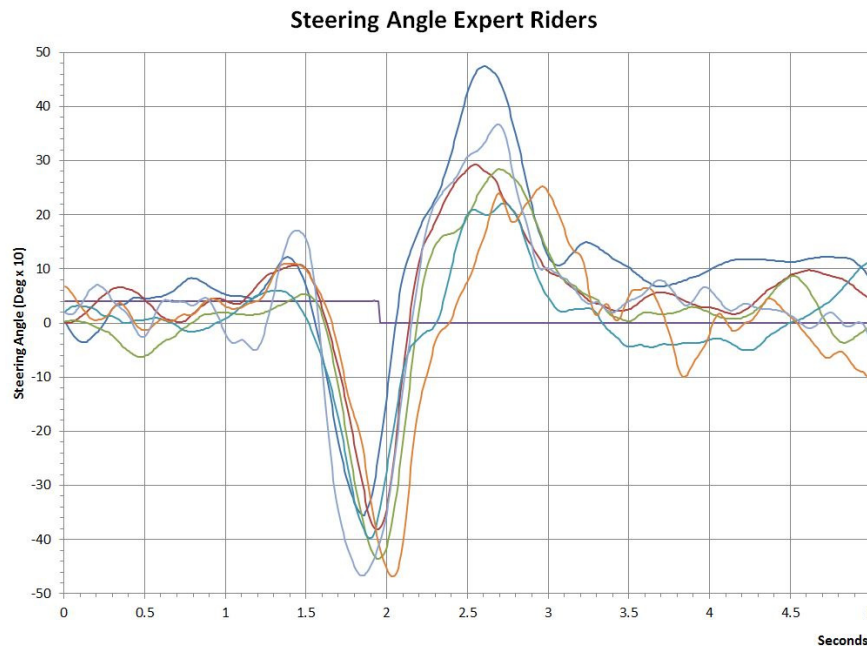

The traces leading to S1 are noisy and it is apparent that the riders are not simply riding straight ahead prior to the swerve manoeuvre. This aspect of rider ability was discussed in chapter 5 when consideration was given to the track width. S2 the peak steer to avoid the cone is in the region of 1.9 seconds and it is obvious that this group are more consistent in their steering to avoid the cone. There are potentially three sub groups within this group of riders, those riders who suddenly countersteer producing a clear peak in the graph e.g. riders 1 & 6 who apply 1.22° and 1.71° respectively figure 85. These two riders do not maintain a steady steering input on the approach to the avoidance manoeuvre, however, they do apply a deliberate steering input which has been identified within the torque assessment where the same two riders applied the greatest force at T1. The magnitude of the steering from S1 to S3 is consistent and both riders reach maximum steering at the same time.

Figure 85 Steering input expert riders 1 & 6

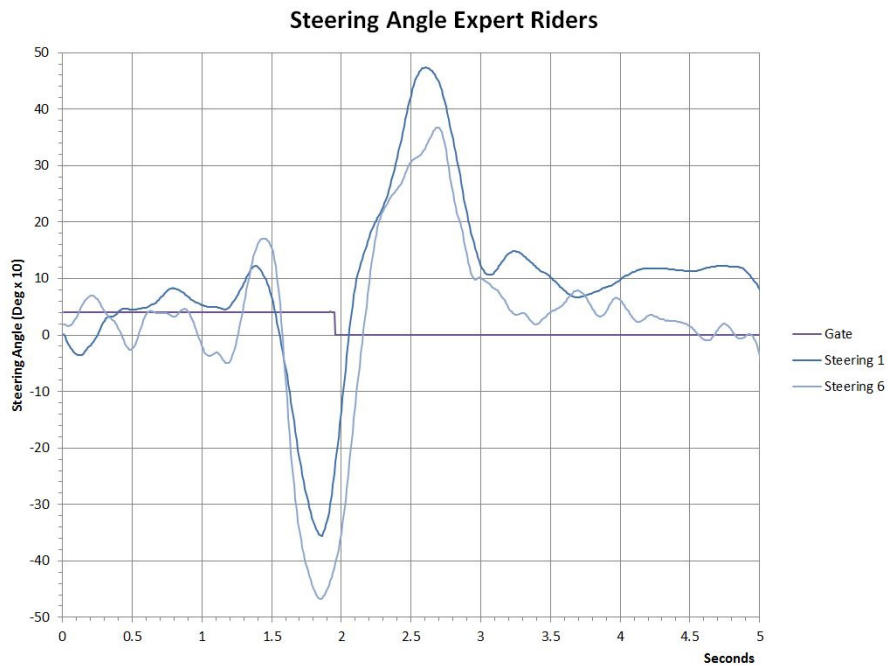

Riders 2 & 5 are also deliberate in their countersteering action; they both apply approximately 1.1° of steering at S1. The manner in which the steering is applied is very similar, they start the steering action at approximately the same time and they both apply the countersteer in two distinct phases.

Figure 86 Steering input expert riders 2 & 5

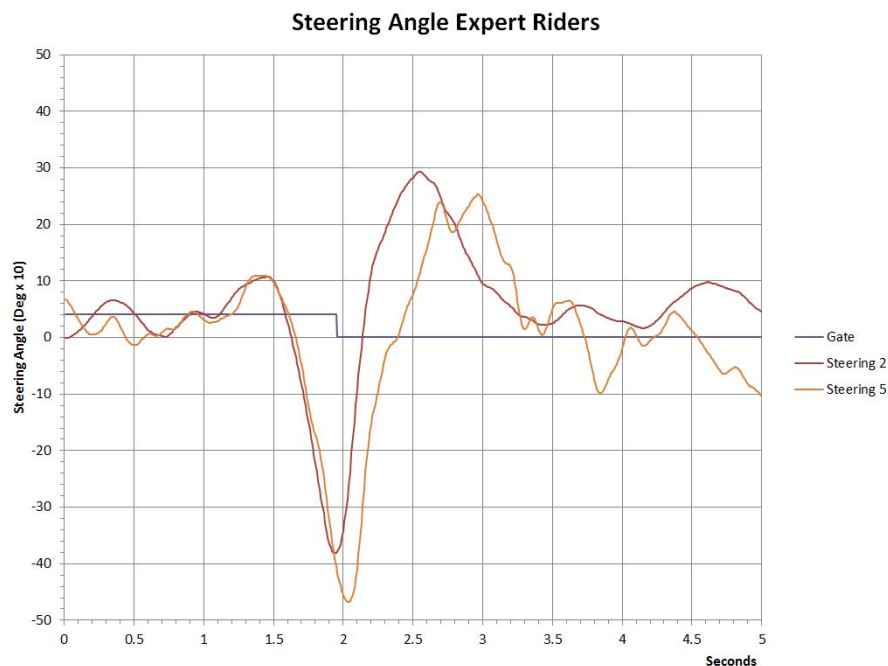

Although they applied the same countersteer and applied it over a similar time scale, they did not apply the same steering force; rider 2 applied 18Nm whilst rider 5 applied 24.6Nm a significant difference of $\approx 7\text{Nm}$.

The final pair of riders, riders 3 & 4 only applied between 0.5° and 0.6° respectively, they did however apply the same steering force of 22.7Nm. This said, it is clear from figure 87 that although the steering input appears to start at the same time, rider 4 initially steers to the right whilst rider 3 steers left. It should be noted that the graph of rider 3 plateaus out before the rider reapplies a force to complete the initiation of the turn. This change in the initiation was not expected at this rider level as it suggests uncertainty. These two riders do not reach S1 at the same time but as expected they do reach S3 at similar times in order to avoid the cone.

Figure 87 Steering input expert riders 3 & 4



The steering data is at table 20, analysis of the angles achieved at S1 by way of the five-figure summary show that the median value is 1.085° , this value is for

the entire group and as has been identified above that there is inconsistency.

The five-figure summary for the angle at S1 is;

(0.53, 0.58, 1.08, 1.35, 1.71) with an i.q.r. of 0.77.

The standard deviation for this data set is $\sigma = 0.44$ with a mean of $\bar{x} = 1.04$.

The data fits well within the mean $\pm 2SD$ and the data is well centred about the median. The time taken from initiation to S1 is also a good fit, within the mean $\pm 1.5SD$. The five-figure summary is;

(0.30, 0.38, 0.70, 0.86, 1.01) with an i.q.r. of 0.48

The standard deviation for this data set is $\sigma = 0.26$ with a mean of $\bar{x} = 0.66$.

The steering angle at S3, the peak avoidance steering angle has been rather imprecise in the other three groups. Using the timing gate as an indicator as to where S3 is reached it is obvious that the novice group are predominantly reaching S3 after the gate, the spread of peaks being over 0.43 seconds. The experienced group have a spread of 0.61 seconds and the peaks are closer to the timing gate. The advanced group only have a time spread of 0.19 seconds and the peaks are predominantly reached prior to the gate. This suggests that the riders are applying the steering very much earlier than the remaining groups.

The time scale between S1 and S3 for this group is also significantly different when compared to the others. A five-figure summary shows that the median is 0.48 seconds compared to the advanced group which is 1.03 seconds.

(0.41, 0.45, 0.48, 0.60, 0.63) with an i.q.r. of 0.15

The standard deviation for this data set is $\sigma = 0.084$ with a mean of $\bar{x} = 0.51$.

The data fits well within the mean $\pm 1.5SD$ and the data is extremely well centred.

The mean time interval from S1 to S3 when compared to the mean time interval between T1 and T3 shows that there is only a 0.52 second difference between the two. For this particular group only the interval between S1 and S3 is shorter than T1 to T3. In all the other groups the time interval between S1 and S3 is greater than T1 to T3.

6.5.2.2 Phase 2 The steering angles during the transition and recovery

For consistency the time interval between S3 and S4 i.e. the time it takes the rider to remove the steering to swerve and return to neutral steer is analysed. Once the neutral steer is reached the rider must then steer back onto the original path in order to stop within the final gate. A five-figure summary of this time interval for this group is;

(0.61, 0.71, 0.79, 0.86, 0.93) with an i.q.r. of 0.15

The standard deviation for this data set is $\sigma = 0.11$ with a mean of $\bar{x} = 0.78$ the mean and median are very close and the standard deviation is approximately 2/3 of the i.q.r. indicating that the data is extremely well centralised. There is again an increase in the mean time taken to execute this part of the manoeuvre when compared to the other groups. It was identified at paragraph 6.4.2.2 that the advanced rider mean time was over 200% that of the novice group and here there is an increase of 1.8% over the advanced group.

6.5.3 Lean angle

6.5.3.1 Phase 1 The initiation of the swerve

The lean angles for this group do not follow the same pattern as the steering angles. The overall plot of the lean angles figure 88 shows that although the traces are similar, there are in fact three separate ways in which the riders have approached the swerve. The graph clearly shows that some riders leaned to the

Figure 88 Lean angles expert riders

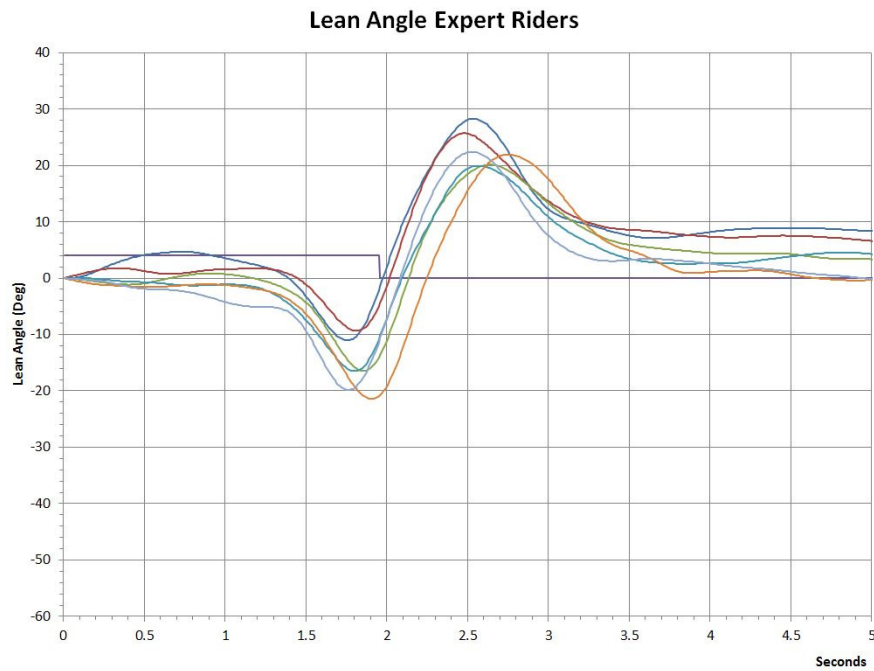

left during the initiation whilst others leaned to their right. Two riders, riders 1 & 2 initially leaned to the left prior to leaning right during the swerve. Figure 89 shows their approach is not the same in that rider 1 leans to an angle of 4.7° . the trace is uniform and shows that the rider commenced the lean at the start of steering/torque application. Rider 2 however only leans to 1.7° and holds that lean for a considerable time before leaning to the right.

Figure 89 Lean angles expert riders 1 & 2



Rider 3 initially leans to the right before leaning left. This trait has not been positively identified in any other group. Riders 6 & 10 in the novice group have a similar trace but there is insufficient evidence to categorically identify that the riders do lean to the right first. This particular expert rider does not lean significantly to the left; the recorded value is only 0.8°. In the novice group the two riders there leaned left 2° and 4° respectively. This rider clearly introduced a steering force close to the mean value but the steer angle at S1 was the smallest of the group at only 5.27°, which is approximately half the mean.

Figure 90 lean angle expert rider 3



The remaining riders, riders 4, 5 & 6 all leaned to the right from the start of steering. This trait has been observed throughout the research. The only difference being the degree of lean at L2 the mean of which has been close throughout.

Figure 91 Lean angles expert riders 4, 5 & 6



A five-figure summary of the lean angles at L2 for this group is;

(9.34, 10.62, 16.46, 20.23, 21.42) with an i.q.r. of 9.61

The standard deviation for this data set is $\sigma = 4.8$ with a mean of $\bar{x} = 15.76$, this data is fairly well centralised but it is noted that the i.q.r. is twice the standard deviation. As discussed above the mean at L2 is similar for all the rider categories the overall mean is 15.02° but the range for all the groups is from 9.34° to 21.4° .

6.5.3.2 Phase 2 The lean angle during the transition and recovery

The maximum lean angle achieved by a rider in this group at L4 was 28.27° the maximum of any rider in the research. The five-figure summary for the group at L4 is;

(19.91, 20.07, 22.14, 26.34, 28.27) with a i.q.r. of 6.27

The standard deviation for this data set is $\sigma = 3.3$ with a mean of $\bar{x} = 23.05$ the data is not particularly well centred; the i.q.r. is approximately twice the standard deviation but the data does fit within the mean $\pm 2SD$.

Figure 92 Expert rider passing the avoidance cone

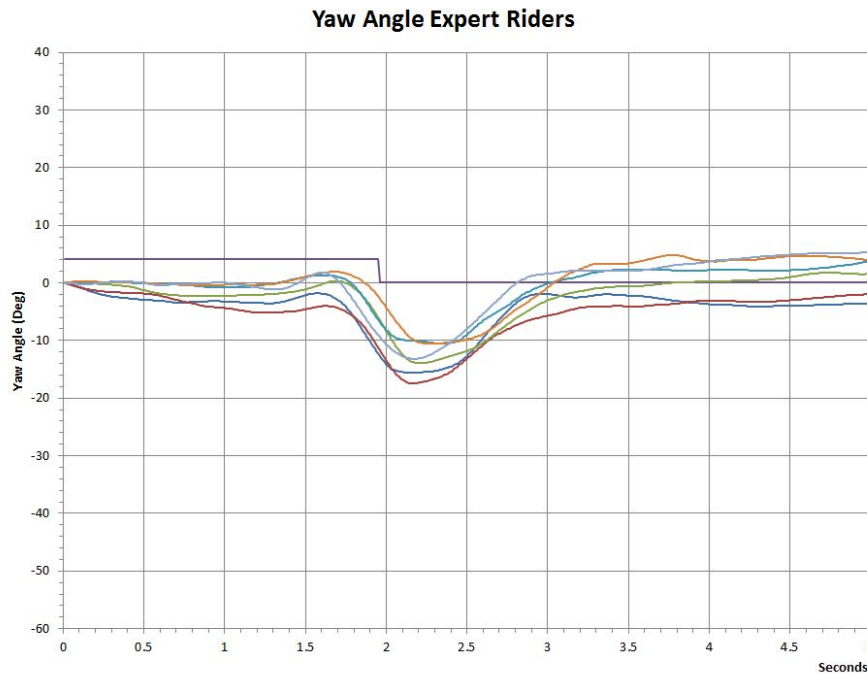

Figure 92 shows one of the expert riders passing the avoidance cone. It was apparent that these riders passed the cone much closer than any of the other groups. In order to do pass the cone so closely they must have achieved the maximum steer angle at L2 in sufficient time to start steering back towards the original course as they were alongside the cone. The angle of lean is 24° but the angle of the rider is approximately 9° from the vertical, hence an angle of approximately 165° between bike and rider. When compared to the advanced rider, the expert rider is more in line with the motorcycle i.e. the rider is leaning with the motorcycle more. The nearside wheel rim is not visible and it is therefore difficult to determine if the rider is actually steering back towards the original course. Observation of the gap (indicated by the white arrow) between the offside of the front tyre and the offside suspension fork is greater than the corresponding gap visible in figure 75, the advanced rider. This suggests that the rider is indeed steering back to the original course.

6.5.4 Yaw angle

The yaw data collected in respect of the expert group is not as expected. It was anticipated that this group would have a very pronounced yaw at Y1, the countersteer region. The force and angle at T1 and S1 were greater than any of the other groups however the yaw angles recorded do not follow a similar pattern. Figure 93 shows the traces of this group in respect of the yaw angles.

Figure 93 Yaw angles expert group



The five-figure summary for this group's angle at Y1 is

$(-4.02, -2.37, 0.84, 1.82, 1.91)$ with an i.q.r. of 4.19

The standard deviation for this data set is $\sigma = 2.4$ with a mean of $\bar{x} = -0.076$ the data is not particularly well centred; the i.q.r. is approximately twice the standard deviation but the data does fit within the mean $\pm 2SD$.

None of the traces leaning to Y1 are positive for at least the first 1.3 seconds. This suggests that either the riders held the motorcycle in neutral yaw or were initially moving across the track to the right. The concept of moving across the track is possible due to the ability of these riders to precisely manoeuvre the motorcycle i.e. they start close to the left of the track, initiate a steer to the right and are travelling in a straight line at an angle to the track when they pass the gate. Examination of the data identifies that as in the advanced group some of the riders do hold a neutral yaw on the approach in particular riders 4, 5 & 6, figure 94.

Figure 94 Yaw angles expert riders 4, 5 & 6



These three riders all hold the machine in neutral yaw prior to the countersteer where the machine suddenly yaws to the left. Other riders start to yaw in a clockwise direction at the start of the manoeuvre but then hold a steady yaw in the region of 1° to 2° before reaching Y1 where the countersteer is very evident. Figure 95 is the traces produced by these riders and although they are slightly negative they do follow the same format as riders 4, 5 & 6 in figure 94 which suggests that the motorcycle is being subjected to similar dynamics but in a slightly different plane.

Riders 1 & 3 produced clockwise yaw of approximately 1.5° on the approach to the manoeuvre. This 'offset' is maintained until the clearly identified positive yaw at countersteer takes place. These traces are very similar to the advanced riders 1, 2 & 7 see figure 79.

Figure 95 Yaw angle expert riders 1 & 3

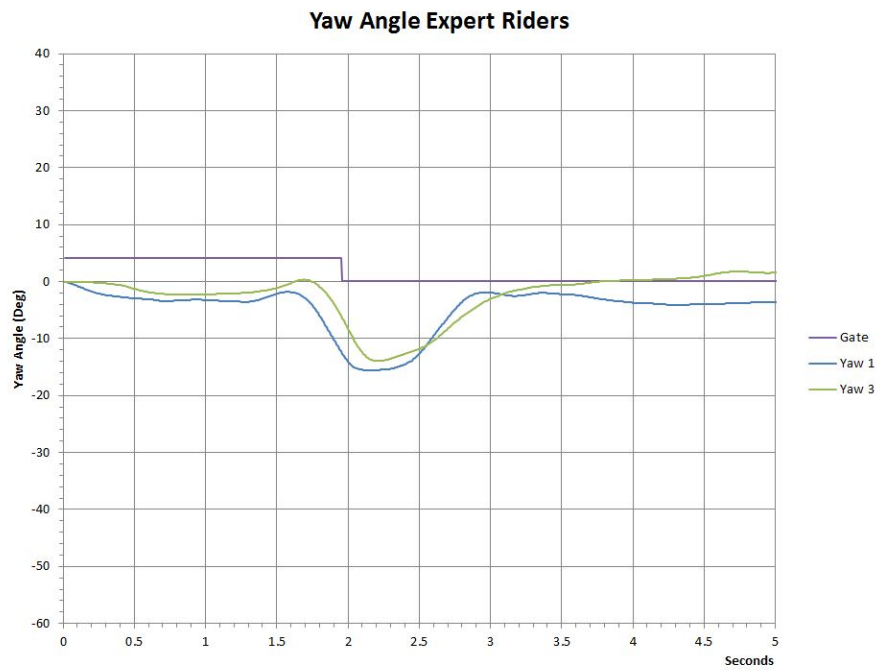

The remaining rider within this group rider 2 causes the motorcycle to yaw in a steady negative slope but the positive yaw at the countersteer is still very evident

Figure 96 Yaw angle expert rider 2

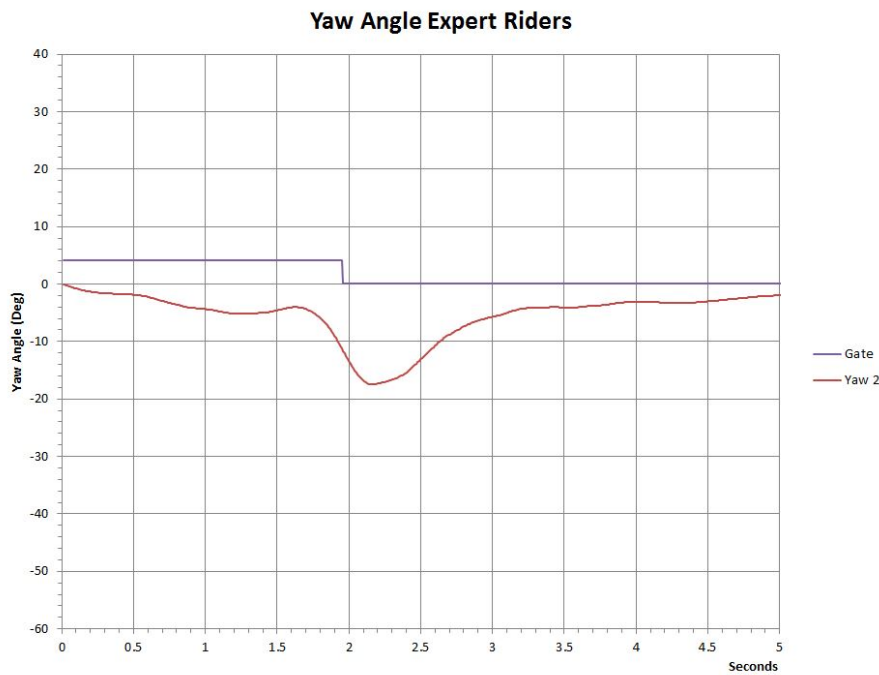

The mean time from Y1 to Y2 is 0.59 seconds is significantly shorter than any of the other groups. It is 39% shorter than the advanced group and 61% shorter than either the experienced or novice groups.

The five-figure summary for Y1 to Y2 is

(0.52, 0.54, 0.57, 0.64, 0.72) with an i.q.r. of 0.10

The standard deviation for this data set is $\sigma = 0.070$ with a mean of $\bar{x} = 0.59$

The mean and median are close as are the i.q.r. and SD indicating a well centred set of data. This mean time is commensurate with the other interval considered i.e. T1 to T3, S1 to S3 where there is only a 5% difference.

The maximum yaw angle at Y2 is 17.45° substantially greater than any other group. The Five-figure summary for this data is

(10.56, 10.57, 13.55, 16.05, 17.45) with an i.q.r. of 5.478

The standard deviation for this data set is $\sigma = 2.7$ with a mean of $\bar{x} = 13.55$.

The mean is ~6% greater than the advanced rider group, 26% greater than the novice group and 34% greater than the experienced rider group.

6.5.5 Observation expert rider group

This group of riders are the most consistent in all the observed aspects. The time interval between T1 to T3 and from S1 to S3 is much shorter than the other groups. As a consequence the torque, countersteer and swerve angles are greater.

As the riders pass the avoidance cone they are at neutral steer or have already started to apply steering back to the left.

The rider maintains a closer alignment to the motorcycle than the experienced and advanced riders but not as rigid as the novice group.

6.6 Conclusions

Throughout this chapter each of the rider groups have been considered on their own merits. Each rider data set within a group has been analysed. No statistical issues have been identified during this process to raise any concerns regarding the integrity of data which could skew the overall results. Therefore, having considered this approach the data for each group has been combined to generate 'mean' data sets. This approach now allows a direct comparison between each group to be made and to allow the major differences between the groups to be identified.

The following four figures show the mean values plotted for each of the four test groups.

Figure 97 The mean input and response of the novice riders

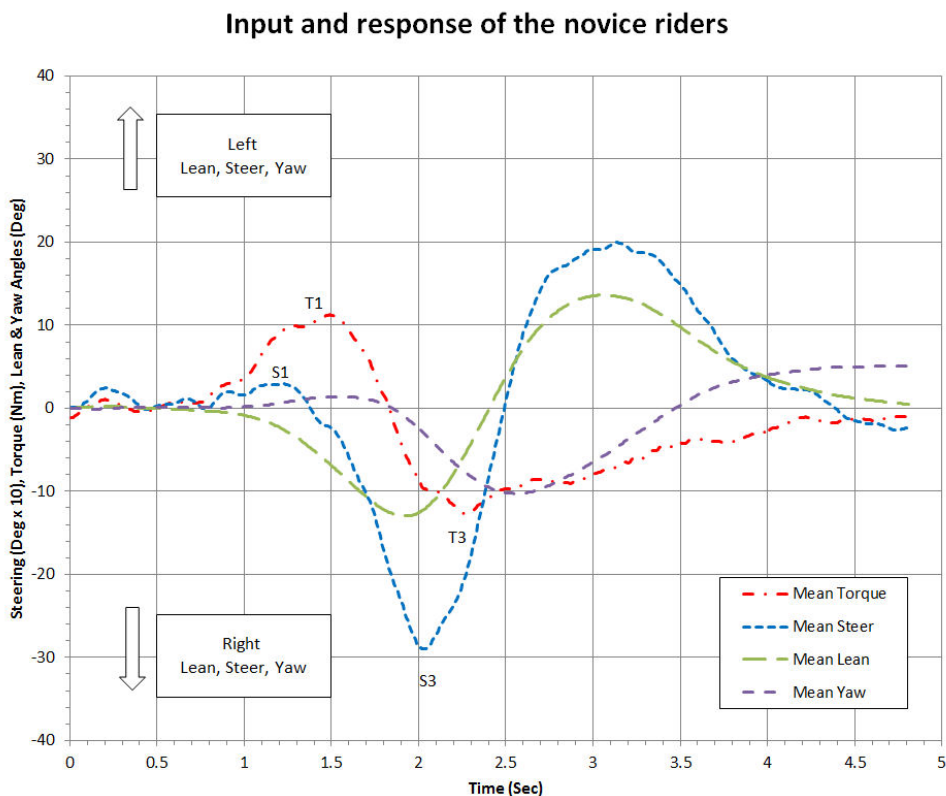
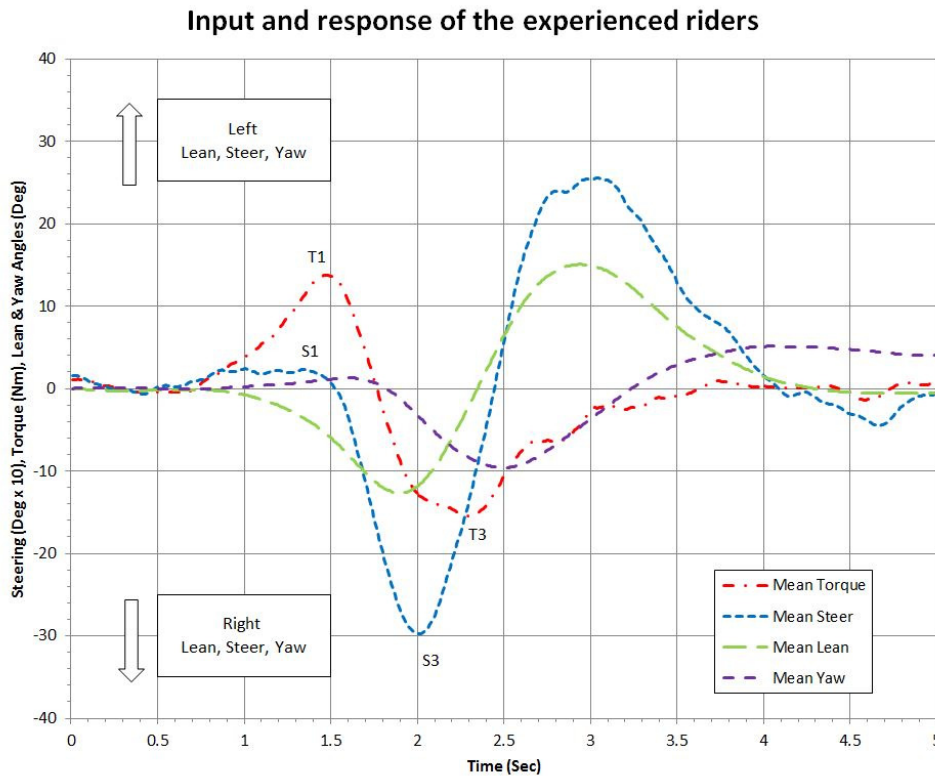

Figure 97 above depicts the mean novice rider inputs, the torque and steering curves are not particularly smooth. This aspect has been discussed within the

previous sections particularly the inconsistency of the riders to recognise the degree of force and steering required. There is however a clear indication of the countersteer at S1. It is also apparent that initially there is only a small reduction in the steering force during the recovery phase at T3 with the riders gradually allowing the force to return to zero at the completion of the exercise. The riders do however achieve in the region of 2° of steering during recovery and this is supported by the lean angle.

The experienced group of riders, as shown in figure 98 below apply the torque leading to T1 in a much more controlled manner producing a smooth curve, the peak force being slightly higher than the novice group. The countersteer angle again appears to be hesitant in its application and there is no clear indication of the countersteer. There is an increase in the torque at T3 but hardly any difference in the swerve angle applied to the steering. The transition from S1 to S3 is both quicker and smoother.

Figure 98 The mean input and response for the experienced group of riders



Although T1 is achieved after S1 this was the same for the novice group, the time interval for the experienced group is however much shorter. During recovery there is an increase in steering angle and this is supported by a deliberate reduction in steering torque at T3 towards neutral. This reduction is short lived with the riders showing no urgency to return to the original line of travel.

The advanced riders mean plot (figure 99) is much smoother and the intervals between T1 to T3 and S1 to S3 are shorter. There is a clear increase in countersteer torque at T1 and there is a defined countersteer at S1. During the recovery phase there is a marked reduction in the steering force after T3 compared to the previous two groups. This is again only short lived and as discussed previously it may be explained by the lack of urgency to return to the original path. There is an increase in the force at T3 compared to the

experienced and novice groups but this is not reflected in the swerve steer angle as there is little difference in any of the groups. There is however a much greater lean angle during recovery and as identified this may be associated to the reduction in steering force post T3.

Figure 99 The mean input and response for the advanced group of riders

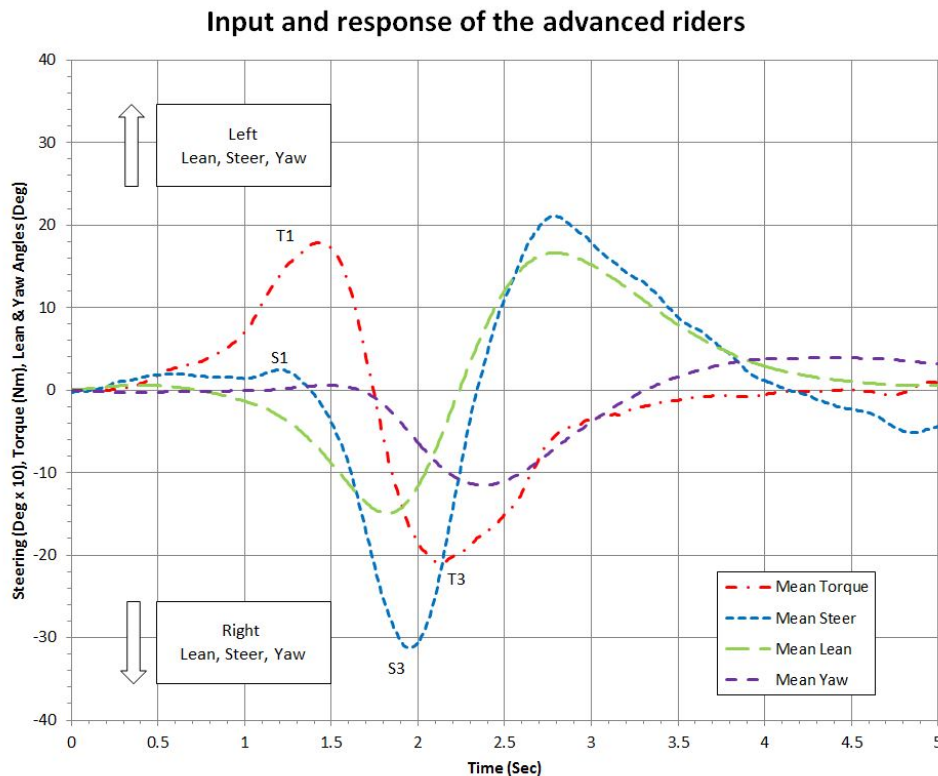
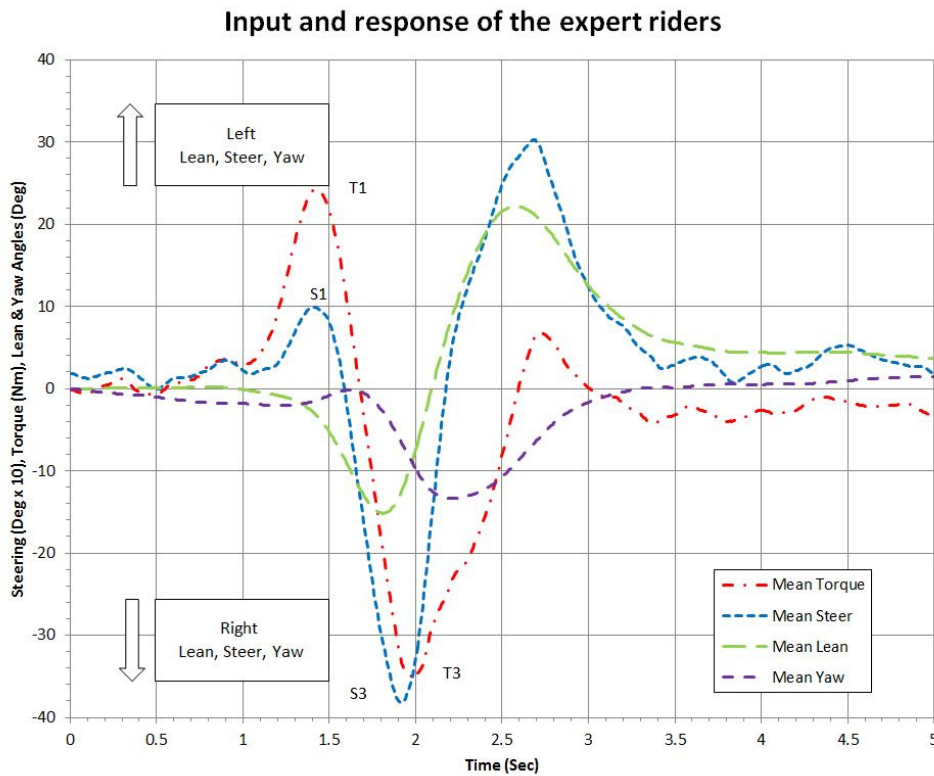

Figure 100 is the mean plot for the expert group of riders, it is immediately apparent that the traces for torque and steering are much more closely aligned. T1 and T3 are extremely close and it may be argued that they are coalesced. Similarly T3 and S3 are much closer than any other group. T1 and T3 are much greater in magnitude and there is a clearly defined countersteer angle. The time intervals between T1 and T3, S1 and S3 are substantially reduced. During recovery there is for the first time a positive torque indicating a very quick return to normality. The yaw trace has for the previous groups always tended to zero on the approach to T1. In this expert group there is a clear indication that the

riders have applied sufficient force and steering into the system to move the motorcycle sufficiently to cause the vehicle to yaw.

Figure 100 The mean input and response for the expert group of riders



The trace of the steering angle although magnified by ten is the most difficult to analyse. The exception being the expert group where there is a significant increase in the countersteer angle at S1.

The most notable differences are the gradual increase in the torque force applied at the countersteer and swerve i.e. T1 and T3 respectively and the steering inputs at S1 to S3. The mean torque comparisons between the groups are shown at figure 101. It can be seen that the force at T1 is increasing and the shape of the trace indicates that the force is applied more quickly by the expert riders. Significantly, the change in direction of the force from T1 to T3 is also much quicker and more forceful.

Figure 101 Comparisons of mean torque forces

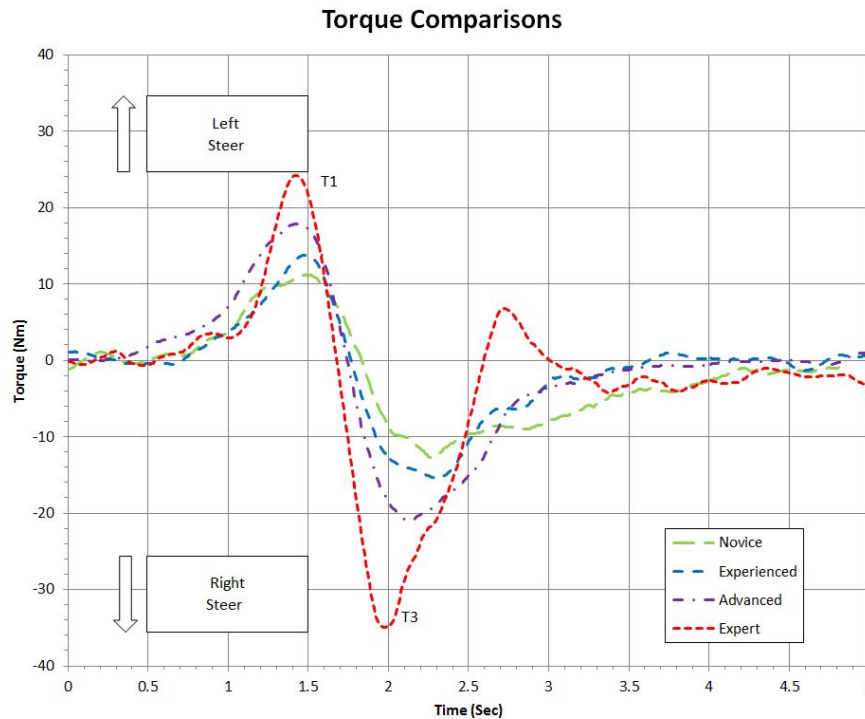

This effect is mirrored in the comparison of steering angles (figure 102) where the strong and deliberate countersteer angle at S1 is very prominent. Similarly the transition from S1 to S3 is also 'stronger' in application and executed over a much shorter time scale than for the other groups.

The comparisons of the steering torque and steering input at the countersteer is best depicted in the following graph (figure 102) where the increase of the force is directly related to the increase in the countersteer angle. The gradients of the traces between T1 and T3 in figure 101 and S1 to S3 in figure 102 clearly indicate the rate of change between the respective points, clearly indicating that the advanced group of riders apply the changes much quicker. This rapid change of force and steering angle then directly influences both the lean and yaw angles depicted in figures 103 and 104.

Figure 102 Comparisons of mean steering angles

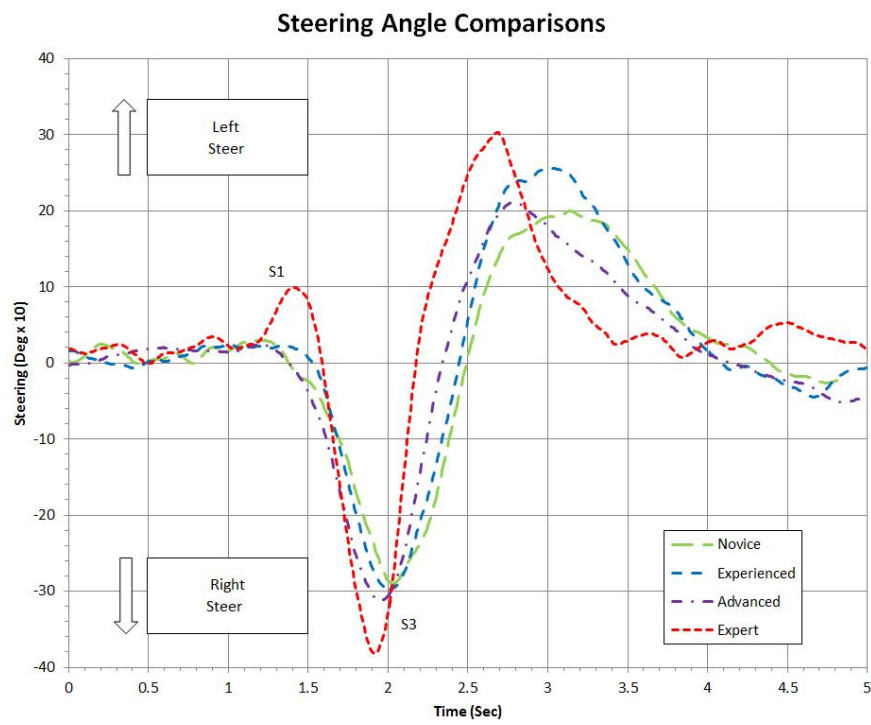

Figure 103 Comparison of mean lean angles

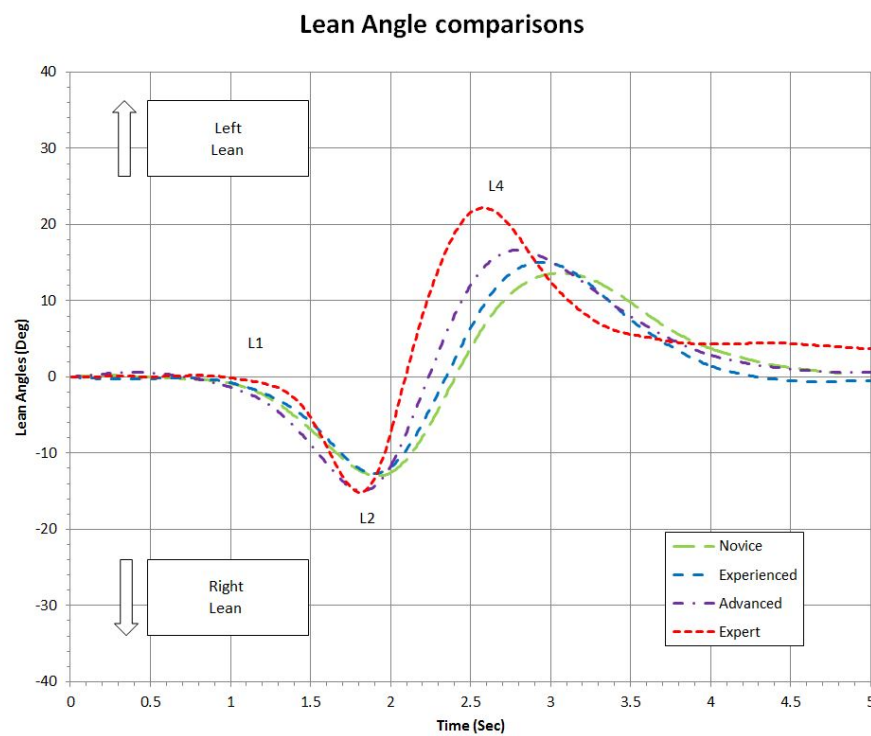
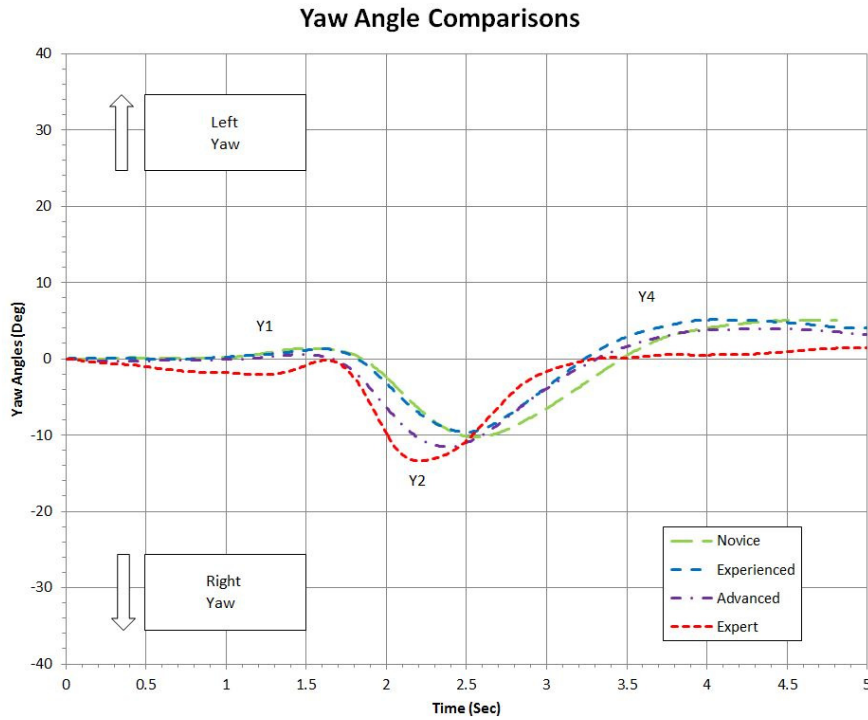

Figure 104 Comparison of mean yaw angles



The reduction in force from the novice to experienced group mirrors the reduced countersteer angle. However the substantially increased steering force observed in the advanced group is not mirrored by a similar increase in the countersteer (S1), in fact the angle is reduced. The expert group however employ much higher steering forces and correspondingly increased countersteer angles. These significant differences are best depicted in figure 105 below.

Figure 105 clearly identifies the differences particularly that the steering force initially drops from the novice to the experienced group but then significantly increases to the maximum achieved by the expert group. As previously discussed the countersteer angle at S1 does not mirror the force applied to the steering. The plot of S1 in figure 105 indicates that there is not a linear relationship between the two.

Figure 105 Mean torque and countersteer angles

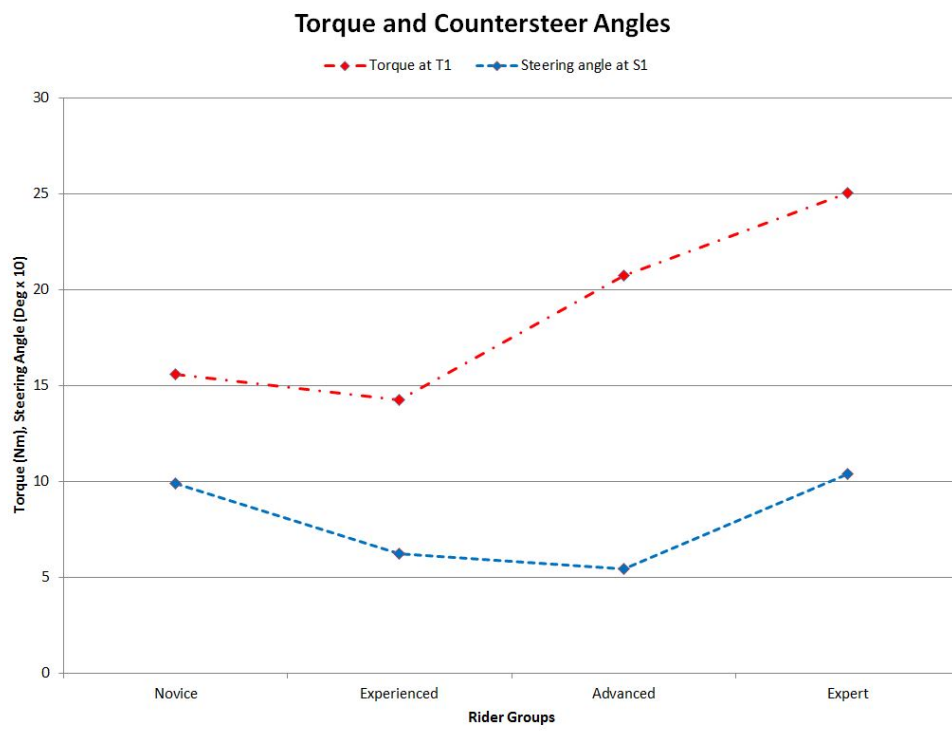

Chapter 7 Key Findings of the Research

7.1 Literature review

Wilson-Jones (1951) suggests that the equilibrium of the conventional bicycle or motor cycle is automatic except at very low speeds.

“In the author’s view (which will be endorsed by any experienced cyclist or motor cyclist) the necessary turning of the steering is entirely automatic except at very low speeds. In fact, at normal speeds, any deliberate turn of the bars, on a solo machine, is apt to have the startling result of causing the machine to steer violently in the opposite direction to that which was intended.” (Wilson-Jones, 1951).

“The initial impulse of turning the handlebars in the opposite direction to the corner you want to take would seem to be an unconscious mechanism developed by the brain as it elaborates a sophisticated control system of which we remain largely unaware. Nobody, it seems, has ever learned to ride a bicycle by analysing the process in a rational way. This impulse gradually becomes a conditioned reflex and every time we ride a bicycle or motorcycle, that mechanism is triggered automatically” (Cocco, 2005).

The Hurt report (Hurt et al., 1981) suggests that the rider’s ability to countersteer and swerve was essentially absent.

If riders employ the ‘out-tracking’ technique to enter a bend, the entering phase may be improved by the rider moving his body laterally. The technique employed by the rider is to transfer weight to the inside of the bend to keep the motorcycle as vertical as possible and enhance tyre to road traction. The employment of this lateral displacement causes the motorcycle to lean and as a

consequence reduces the size of the initial countersteer angle. Two hypotheses are presented (Ethier, 2000), firstly where the rider uses his torso lean angle to control the motorcycle lean angle and secondly where the rider's arms link the rider's torso and handlebars in a non-obvious but precise way.

Varet et al. (2004) examined a lane change manoeuvre comparing three different types of motorcycle. They employed two riders who had the relevant experience. One who had extensive 'dirt bike' experience to ride the off road machine and one who had mostly road bike experience and limited off road experience rode the sports and touring machine. No additional information was given regarding any additional or advanced training qualifications, suggesting that the riders were qualified by experience and not necessarily by qualification.

Countersteering is not a subject in the DSA publication "*The Official DSA Guide to Riding the essential skills*" and it is not a subject taught or included in the police rider training syllabus.

7.2 Questionnaire results

The statistical analysis of the questionnaire data (chapter 4), showed that there is only weak evidence (*Probability level (under null hypothesis) $p=0.188$*) of an association between training and performance in swerve to avoid incidents.

The majority of riders are familiar with the term 'countersteering' and they know it has something to do with how the machine is steered. The majority of those riders who had attended a training course in addition to the basic training required to pass the 'driving test' believed it was either a 'Different way of steering' or a 'Gyroscopic effect'. When riders were asked to decide what

countersteering was, over half said it allowed riders to corner more safely and 19% believed it was an avoidance technique. If this is a true reflection of the motorcycle instruction which is being delivered, it would appear that the basics of motorcycle steering are not understood or not being adequately explained.

7.3 Experimental design

The experimental design was developed from the DOT off-road assessment as it was considered to be the most appropriate. In any swerve to avoid scenario it is the ability of the rider to initially avoid the obstacle and then to return to the original line of travel as quickly as possible in order to avoid any other traffic e.g. if the swerve takes the rider onto the opposing traffic lane it is essential to exit that lane as soon as possible to avoid any opposing traffic. Therefore, the attitude of the motorcycle at the point it passes the obstacle indicates the effectiveness of the swerve, not only to avoid the obstacle but also demonstrates the rider's ability to return to normality.

7.3.1 Rider groups

Four groups of rider ability were used for the study, each group being selected to represent a different section of the overall rider population. All the riders were volunteers and none had any influence on the testing procedure.

7.4 Experimental work

Characteristics of motorcycle steering have been observed which correspond closely to those found in the literature. Much of the literature concentrates on motorcycle design and types and not the experience of the individual riders.

It must be noted that when the mean values of all the individual runs within in a group are taken the peak values plotted are not necessarily the same as those quoted where the mean peak values are taken. This is because when as the individual runs are collated they are zeroed at the point where the rider first

starts to initiate the countersteer and the time intervals to the individual peak values are not the same.

Significant differences in the steering force (T1) and the countersteer angle (S1) have been observed in the raw data. The experienced group applied the least amount of force to initiate the turn but then there was a significant increase to the advanced group and a second increase to the expert group. The novice and expert groups produced significantly greater countersteering angles when compared to the experienced and advanced groups. Figure 106 show this comparison together with standard error bar lines. The error bars used in figures 106, 107 and 108 represent 1 standard error (s.e.) in either direction.

Figure 106 Mean Torque and Countersteer Angles

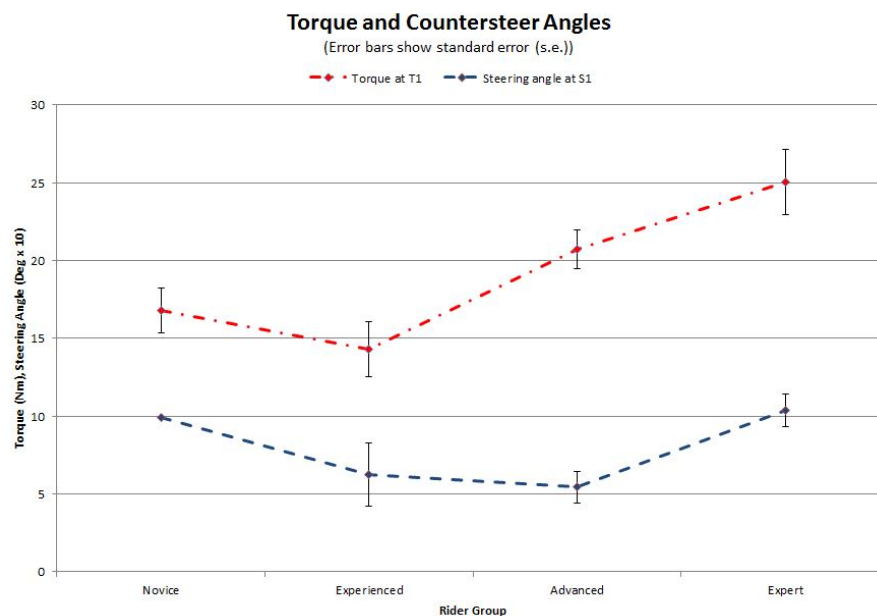

Similarly there are observed differences between the individual peak steering forces and the swerve angles (S3). The steering force (torque) gradually increased from novice through experienced and the advanced groups to the

maximum at the expert group. It has been observed that the novice group applied a greater a greater mean peak value than the experienced group.

Figure 107 Mean Torque and Swerve angle

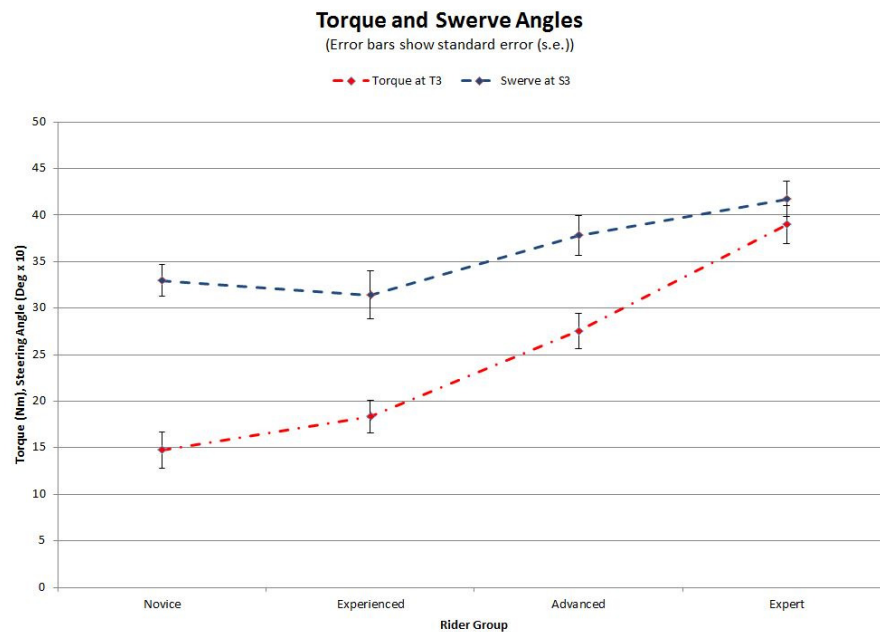

A major steering characteristic observed is the rate at which the steering forces change between T1 & T2 and the rate at which the steering angles between S1 & S3 are applied. It is observed that the time interval increases for the novice, experienced and advanced groups, but there is a reduction in time for the expert group. This is best depicted in figure 108 and reference to figures 101 and 102, pages 186 and 187 respectively.

Figure 108 Mean times between T1-T3 & S1-S3

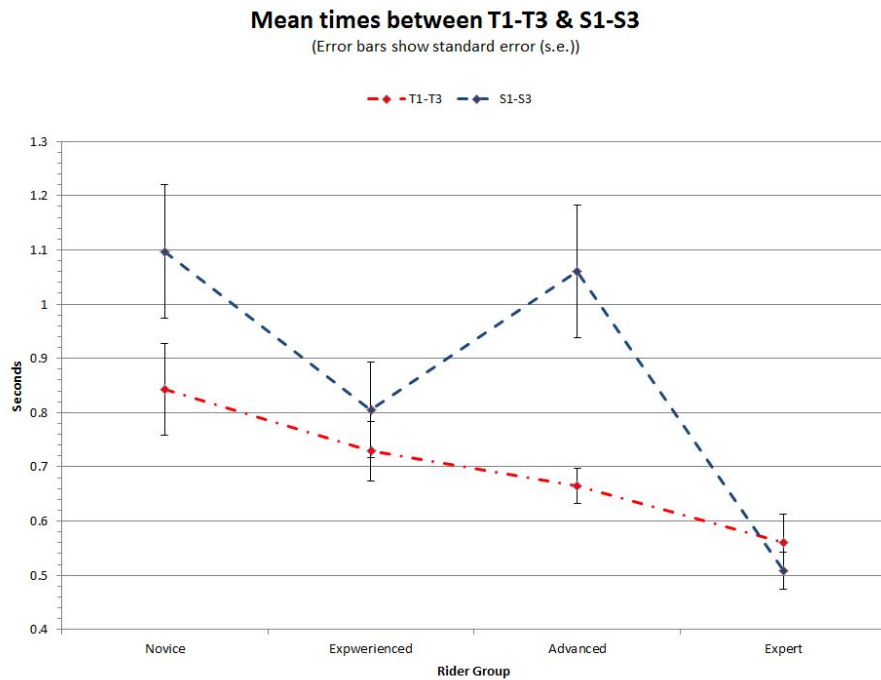

7.4.1 Rider conditioning

Clearly for statistical purposes it would be advantageous to have larger data sets for the rider categories. It would have been possible to allow riders to repeat the test a number of times until such time that they achieved tests that were consistent e.g. 30mph for every run. The danger identified was that of ‘conditioning’ and it was decided at an early stage that the tests must be spontaneous with only limited familiarisation with the motorcycle and the test course.

To maintain balance and stability whilst negotiating a curvilinear path at speed requires that the motorcycle and rider are both leaned over. Spiegel (2010) suggests that the maximum natural lean angle is 20° and that any increase in that angle requires practice.

7.5 Video Imaging

Different rider, motorcycle and steering angles were captured using a Canon single lens reflex (SLR) camera with video capability. This allowed individual frames to be taken out of the video without the characteristic shadow of traditional video camera footage.

Figure 109 Rider and Motorcycle Angles



Figure 104, from top to bottom, Novice, Experienced, Advanced and Expert riders.

Differences in the rider and motorcycle angles have been observed, (Chapter 6, paragraphs 6.2.3, 6.3.3, 6.4.3 and 6.5.3 refer).

Significant differences have also been observed in the steering angle of the motorcycle as it passed the avoidance cone. The Novice and Experienced riders were still steering away (front wheel rim visible). It is impossible to determine if the Advanced rider was steering back but observation in relation to the front suspension do suggest the Expert riders were.

7.6 Statistical testing of the collected data

No significant anomalies have been found in any of the data sets collected.

Each rider group has been examined and found to be consistent.

- No significant differences have been found in the first three rider groups
- A significant difference in the steering forces and countersteer angles has been established between the novice, experienced and advanced rider groups when compared to the expert rider group.

Chapter 8 **Conclusions Drawn from the Research**

The main aim of the research was to develop a better understanding of rider steering inputs and evaluate the strength of each rider group based on their training / experience.

The known problems to do with countersteering have been exposed by both questionnaire and empirical testing. The questionnaire identified a lack of understanding by riders and the analysis by testing has quantified the normal steering force and countersteer angle under a simple swerve scenario. The results imply that a rider can execute the same manoeuvre with greater efficiency when trained to a higher degree.

The individual contributions to the steering system of a single-track vehicle have been studied. The results show that riders who have received comprehensive training beyond that required by the Department of Transport perform better. In contrast, experience has been shown not to be a substitute for training.

It has been shown that riders trained to a higher level are less likely to be victim of the approaching vehicle during the swerve to avoid manoeuvre as they are able to recover from the initial swerve and return to the correct path more quickly. The results indicate that peak gains associated with the steering force are associated with this category of rider.

The work reported here has a number of practical consequences. It appears to provide an explanation for the vehicle/rider loss of control in swerve to avoid scenarios. It helps to explain why motorcyclists who ride perfectly well for many years can suffer serious and potentially fatal incidents when faced with a particular emergency situation. In terms of road safety there are potential gains to be made with the investment in additional rider training programs.

In line with the main aim of the study it was concluded that:

- Lateral movement of the body may be used to reduce the countersteer angle required to initiate the turn ('out-tracking').
- It is accepted that the steering is only turned a very small amount at normal riding speeds (30mph / 13.41ms^{-1}) and therefore the resultant

precessional force is small. With rapid application of greater steering angles, potentially 500% greater, the resultant angular velocity will be greater.

- Precise application of the steering force by riders who have received comprehensive training beyond that required by the Department of Transport exacerbate the gyroscopic effect using the resultant precession to maximum benefit.
- Early application of a strong steering force achieves a greater countersteer angle producing a good initiation of the swerve manoeuvre.
- The time interval between application and effect is significantly reduced.
- The time interval between countersteer and the swerve manoeuvre is also significantly reduced allowing the recovery to commence earlier. The direct effect being the rider's exposure to potential danger is greatly reduced.

References

- AOKI, A. (1980) "Experimental Study on Motorcycle Steering Performance" SAE 790265
- CLARKE, D.D., WARD, P., BARTLE, C. & TRUMAN (2004) "In-depth Study of Motorcycle Accidents". University of Nottingham.
- COCCO, G. (2005) *Motorcycle Design and Technology*, Giorgio Nada Editore ISBN 978-0-7603-1990-1
- CODE, K (1993) *A Twist of the Wrist*, California Superbike School. ISBN 0-9650450-1-3
- COSSALTER, V (2006) *Motorcycle Dynamics*, Lulu ISBN 978-1-4303-0861-4
- DETR (2000) *Tomorrows Roads – Safer for Everyone: The Government's road safety strategy and casualty reduction targets for 2010*. HMSO
- ETHIER, P. M. (2000) *Motorcycle-Rider Servomechanism Steering Theory*, SAE 2000-02-3565
- FAJANS, J. (1999) *Steering in bicycles and motorcycles. Department of Physics, University of California, Berkeley, California 94720-7300*
- FOALE, T. (2006) *Motorcycle Handling and Chassis Design the Art and Science*. Tony Foale Designs. ISBN 84-933286-3-4
- GRAY, A. (1918) *A Treatise on Gyrostatics & Rotational Motion*. MacMillan & Co. Ltd. ISBN 1-4212-5592-8

- HEISLER, H. (2002) *Advanced Vehicle Technology*, 2nd Edition Butterworth Heinemann.
ISBN 978-0-7506-5131-8
- HILLIER, V. A. W. & COOMBES, P. (2004) *Hilliers Fundamentals of Motor Vehicle Technology*. 5th Edition Nelson Thornes.
ISBN 978-078780822
- HURT, H. H., OUELLET, J. V. & THOM, D. R. (1981) *Motorcycle Accident Cause Factors and Identification of Countermeasures*. U.S. Department of Transport, Vol. 1.
- JAMA (2010) *Production & Export Summary*. Japan Automobile Manufacturers Association.
- KASANICKY, G., PAVOL, K. & PRIESTER, J. (2003) *Analysis of single-track vehicle accidents*, University of Zilina.
ISBN 80-7100-599-1
- KIMISHIMA, T., NAKAMURA, T. & SUZUKI, T. (1997) The Effects on Motorcycle Behavior of the Moment of Inertia of the Crankshaft. *SAE 971060*.
- MCKIBBEN, J. S. (1978) *Motorcycle Dynamics – Fact, Fiction and Folklore*. *SAE 780309*.
- MEDWEL, C. J., MCCARTHY, J.R. & SHANAHAN, M.T. (1997) *Motorcycle Slide to Stop Tests* *SAE 780312*
- PACEJKA, H. B. (2007) *Tyre and vehicle Dynamics*, Butterworth-Heinemann.
ISBN 978-0-7506-6918-4
- RICE, R. S. (1979) *Rider Skill Influences on Motorcycle Maneuvering*. *SAE 780312*.
- ROBINSON, J. (1997) *Motorcycle Tuning*, Butterworth-Heinemann.
ISBN 0-7506-1840-X

SHARP, R. S. (1971) The Stability and Control of Motorcycles. Jour: Mech. Eng. Sci. 13(5). 316-329.

SHARP, R. S. (2001) Stability and steering Responses of Motorcycles. *Vehicle System Dynamics*, Vol. 35, pp.299-326.

SPIEGEL, B. (1989) Was hat der Mesokosmos-Begriff auf einer Motorradtagung zu suchen? *Eröffnungs-vortrag auf der 3. VDI-Motorradtagung in Darmstadt. VDI-Berichte No.779*

SPIEGEL, B. (2010) *The Upper Half of the Motorcycle on the unity of rider and machine*. Whitehorse Press.
ISBN 978-1-884313-75-2

THE DRIVING STANDARDS AGENCY (2008) *The Official DSA Guide to RIDING the essential skills*, The Stationary Office.
ISBN 978-0-11-552644-2

VARAT, M. S., HUSHER, S. E., SHUMAN, K. F. & KERKHOFF, J. F. (2004) Rider Inputs and Powered Two Wheeler Response for Pre-Crash Maneuvers. *KEVA Engineering*.

WILSON-JONES, R. A. (1951) Steering and Stability of Single-track Vehicles. *Proceedings of the Institution of Mechanical Engineers 1951*.

ZELLER, J. W. & WEIR, D. H. (1978) Development of Handling test procedures for Motorcycles. *SAE 780313*.

Data Tables

Table 7 Torque input novice group

Torque Input Novice Group						
Run	Start time before Gate (Sec)	Time to T1 (Sec)	Force at T1 (Nm)	Time to T3 (Sec)	Time between T1 & T3 (Sec)	Force at T3 (Nm)
1	0.5	0.63	17.969	1.19	0.56	-21.596
2	0.65	1.09	22.571	1.99	0.9	-9.652
3	0.73	1.15	16.056	2.0	0.85	-13.128
4	0.67	0.61	13.682	1.48	0.87	-15.72
5	0.34	1.49	17.891	2.08	0.59	-8.924
6	0.33	0.81	19.16	1.55	0.74	-26.87
7	0.34	1.08	24.235	2.58	1.5	-16.511
8	0.59	0.53	13.696	1.5	0.97	-14.801
9	0.15	0.68	13.489	1.5	0.82	-15.27
10	0.56	0.3	9.113	0.93	0.63	-5.0
Mean	0.486	0.837	16.786	1.68	0.848	-14.747

Table 8 Steering input novice group

Steering Input Novice Group							
Run	Time to S1 (Sec)	Angle at S1 (Degrees x 10)	Time to S3 (Sec)	Angle at S3 (Degrees x 10)	Time between S1 & S3 (Sec)	Time to S4 (Sec)	Time between S3 & S4 (Sec)
1	0.18	3.27	1.21	-31.22	1.03	1.56	0.35
2	0.3	8.68	1.66	-25.02	1.36	2.08	0.42
3	0.17	4.18	1.92	-36.78	1.75	2.39	0.47
4	0.61	8.45	1.42	-36.55	0.81	1.86	0.42
5	0.46	11.05	1.98	-27.45	1.52	2.31	0.33
6	0.34	9.36	1.57	-35.18	1.23	1.78	0.21
7	1.09	23.04	1.71	-32.9	0.62	2.1	0.39
8	0.18	5.32	1.45	-35.43	1.27	1.91	0.46
9	0.47	6.71	1.14	26.58	0.67	1.5	0.36
10	0.33	18.93	1.04	-42.59	0.71	1.4	0.36
Mean	0.413	9.899	1.536	-32.97	1.097	1.889	0.377

Table 9 Lean angle novice group

Lean Angle Novice Group							
Run	Time to Max Angle L1 (Sec)	Max angle in L1 (Degrees)	Time to L2 (Sec)	Angle at L2 (Degrees)	Time to L4 (Sec)	Angle at L4 (Degrees)	Time between L2 & L4 (Sec)
1			0.97	-13.3014	2.31	13.98	1.34
2	0.29	2.43	1.6	-12.8601	3.1	13.587	1.5
3	0.17	0.576	1.76	-14.131	2.87	8.316	1.11
4			1.29	-15.36	2.94	9.64	1.65
5	0.35	3.099	1.85	-14.276	2.92	14.642	1.07
6	0.17	1.923	1.3	-14.115	2.27	17.805	0.97
7	0.76	5.187	1.6	-12.01	2.75	23.232	1.15
8	0.1	1.443	1.19	-13.185	2.38	12.978	1.19
9			1.02	-20.2457	2.01	8.3496	0.99
10	0.07	4.252	0.93	-16.095	1.91	17.786	0.98
Mean	0.273	2.701	1.35	-14.558	2.546	14.032	1.195

Table 10 Yaw angle novice group

Yaw Angles Novice Group					
Run	Time to Y1 (Sec)	Angle at Y1 (Degrees)	Time to Y2 (Sec)	Angle at Y2 (Degrees)	Time between Y1 & Y2 (Sec)
1	0.75	-0.5	1.63	11.14	0.88
2	1.33	-1.61	2.32	9.88	0.99
3	1.32	-3.36	2.36	7.88	1.04
4	0.84	-1.85	1.89	9.75	1.05
5	1.24	-3.8	2.4	8.78	1.16
6	1.03	-0.94	1.85	13.86	0.82
7	1.35	-1.82	2.23	12.92	0.88
8	0.83	-2.45	1.93	10.78	1.1
9	0.8	-3.02	1.62	9.06	0.82
10	0.69	-1.5	1.46	13.72	0.77
Mean	1.018	-2.085	1.969	10.777	0.951

Table 11 Torque input experienced group

Torque Input Experienced Group						
Run	Start time before Gate (Sec)	Time to T1 (Sec)	Force at T1 (Nm)	Time to T3 (Sec)	Time between T1 & T3 (Sec)	Force at T3 (Nm)
1	0.56	0.68	15.535	1.61	0.93	-10.793
2	0.32	0.57	13.352	1.40	0.83	-12.998
3	0.47	0.83	11.808	1.58	0.75	-14.138
4	0.33	0.75	5.995	1.55	0.80	-15.623
5	0.40	0.72	26.995	1.15	0.43	-16.914
6	0.45	0.84	14.028	1.34	0.50	-19.377
7	0.41	0.77	9.534	1.61	0.84	-27.707
8	0.35	0.90	13.416	1.47	0.57	-24.294
9	0.40	0.53	13.501	1.45	0.92	-24.163
10	0.38	1.09	18.547	1.81	0.72	-17.726
Mean	0.41	0.77	14.271	1.49	0.73	-18.373

Table 12 Steering input experienced group

Steering Input Experienced Group							
Run	Time to S1 (Sec)	Angle at S1 (Degrees x 10)	Time to S3 (Sec)	Angle at S3 (Degrees x 10)	Time between S1 & S3 (Sec)	Time to S4 (Sec)	Time between S3 & S4 (Sec)
1	0.53	6.47	1.31	-31.39	0.78	1.77	0.46
2	0.32	5.17	1.05	-28.3	0.73	1.51	0.46
3	0.48	8.73	1.24	-20.64	0.76	1.73	0.49
4	0.10	2.53	1.31	-22.95	1.21	1.70	0.41
5	0.72	13.77	1.15	-42.92	0.43	1.58	0.43
6	0.77	2.76	1.32	-33.83	0.55	1.67	0.35
7	0.16	4.85	1.29	-25.88	1.13	1.74	0.45
8	0.21	6.2	1.41	-32.9	1.20	1.74	0.33
9	0.41	5.13	1.11	-28.77	0.60	1.67	0.56
10	1.00	6.7	1.66	-46.5	0.66	2.01	0.35
Mean	0.47	6.23	1.29	-31.41	0.81	1.71	0.43

Table 13 Lean angle experienced group

Lean Angle Experienced Group							
Run	Time to Max Angle L1 (Sec)	Max angle in L1 (Degrees)	Time to L2 (Sec)	Angle at L2 (Degrees)	Time to L4 (Sec)	Angle at L4 (Degrees)	Time between L2 & L4 (Sec)
1			1.22	-12.9	2.44	14.86	1.22
2			0.95	-13.69	1.99	13.12	1.04
3	0.28	1.92	1.17	-8.17	2.25	16.14	1.08
4			1.18	-10.14	2.31	15.43	1.13
5	0.24	2.24	1.13	-13.13	2.14	16.27	1.01
6			1.22	-12.56	2.12	16.19	0.9
7			1.18	-17.03	2.27	11.84	1.09
8			1.28	-13.72	2.19	13.92	0.91
9			1.06	-11.18	2.07	19.67	1.01
10	0.16	1.96	1.52	-17.74	2.46	18.01	0.94
Mean			1.19	-13.03	2.22	15.54	1.03

Table 14 Yaw angle experienced group

Yaw Angles Experienced Group					
Run	Time to Y1 (Sec)	Angle at Y1 (Degrees)	Time to Y2 (Sec)	Angle at Y2 (Degrees)	Time between Y1 & Y2 (Sec)
1	0.8	-1.37	1.87	11.05	1.07
2	0.6	-0.91	1.62	10.49	1.02
3	0.75	-0.16	1.83	10.94	1.08
4	0.2	-0.38	1.83	10.82	1.63
5	0.9	-3.03	1.58	7.83	0.68
6	0.9	-0.13	1.68	9.31	0.78
7	0.85	-2.84	1.79	8.31	0.94
8	0.95	-1.69	1.71	7.94	0.76
9	0.6	-1.07	1.7	11.84	1.1
10	1.22	-3.16	2.04	11.96	0.82
Mean	0.78	-1.47	1.77	10.05	0.99

Table 15 Torque input advanced group

Torque Input Advanced Group						
Run	Start time before Gate (Sec)	Time to T1 (Sec)	Force at T1 (Nm)	Time to T3 (Sec)	Time between T1 & T3 (Sec)	Force at T3 (Nm)
1	0.46	0.50	20.354	1.14	0.64	-35.806
2	0.65	0.71	29.347	1.43	0.72	-35.335
3	1.93	1.30	22.75	1.90	0.60	-31.74
4	0.98	1.04	18.369	1.88	0.84	-31.538
5	0.52	0.68	22.949	1.24	0.56	-23.54
6	1.35	0.70	17.422	1.41	0.71	-25.405
7	0.51	0.40	16.541	1.08	0.68	-26.999
8	1.65	1.27	18.422	1.77	0.50	-17.604
9	1.60	1.00	23.502	1.78	0.78	-25.124
10	1.46	0.89	17.738	1.51	0.62	-22.368
Mean	1.11	0.85	20.739	1.51	0.67	-27.546

Table 16 Steering input advanced group

Steering Input Advanced Group							
Run	Time to S1 (Sec)	Angle at S1 (Degrees x 10)	Time to S3 (Sec)	Angle at S3 (Degrees x 10)	Time between S1 & S3 (Sec)	Time to S4 (Sec)	Time between S3 & S4 (Sec)
1	0.16	3.24	0.89	-39.49	0.73	1.62	0.73
2	0.72	10.71	1.34	-34.67	0.62	2.12	0.78
3	0.25	1.78	1.80	-29.29	1.55	2.51	0.71
4	0.21	2.29	1.68	-26.17	1.47	2.65	0.97
5	0.61	8.43	1.17	-44.06	0.56	2.13	0.96
6	0.34	3.12	1.37	-35.76	1.03	1.90	0.53
7	0.33	7.73	1.08	-47.99	0.75	1.94	0.86
8	0.24	3.9	1.67	-44.93	1.43	2.47	0.80
9	0.27	9.74	1.70	-36.11	1.43	2.31	0.61
10	0.44	3.50	1.47	-39.49	1.03	2.20	0.73
Mean	0.36	5.44	1.42	-37.79	1.06	2.19	0.77

Table 17 Lean angle advanced group

Lean Angle Advanced Group							
Run	Time to Max Angle L1 (Sec)	Max angle in L1 (Degrees)	Time to L2 (Sec)	Angle at L2 (Degrees)	Time to L4 (Sec)	Angle at L4 (Degrees)	Time between L2 & L4 (Sec)
1	Before Torque	1.21	0.91	-15.24	1.80	22.85	0.89
2	0.25	0.922	1.13	-16.45	2.00	25.02	0.87
3			1.64	-13.09	2.49	19.04	0.85
4			1.44	-13.17	2.51	19.08	1.07
5	Before Torque	2.50	1.06	-15.80	2.11	18.21	1.05
6			1.16	-17.00	2.07	13.79	0.91
7			0.89	-17.97	1.90	14.30	1.01
8	0.06	0.75	1.57	-21.14	2.49	13.66	0.92
9	0.19	3.20	1.51	-18.54	2.42	16.00	0.91
10			1.36	-18.81	2.19	16.51	0.83
Mean			1.26	-16.72	2.20	17.85	0.93

Table 18 Yaw angle advanced group

Yaw Angle Advanced Group					
Run	Time to Y1 (Sec)	Angle at Y1 (Degrees)	Time to Y2 (Sec)	Angle at Y2 (Degrees)	Time between Y1 & Y2 (Sec)
1	0.29	-1.67	1.23	12.17	0.94
2	0.92	-0.98	1.66	15.65	0.74
3	1.42	-0.29	2.16	11.45	0.74
4	1.00	-1.07	2.09	11.17	0.99
5	0.82	-1.79	1.51	12.00	0.69
6	0.82	-1.05	1.67	12.40	0.85
7	0.54	-0.42	1.33	13.93	0.79
8	1.10	-2.31	2.02	11.92	0.92
9	1.13	-2.05	1.99	11.82	0.86
10	0.87	-1.67	1.81	12.17	0.94
Mean	0.89	-1.33	1.75	12.47	0.85

Table 19 Torque input expert group

Torque Input Expert Group						
Run	Start time before Gate (Sec)	Time to T1 (Sec)	Force at T1 (Nm)	Time to T3 (Sec)	Time between T1 & T3 (Sec)	Force at T3 (Nm)
1	1.58	1.02	30.496	1.49	0.47	-35.54
2	1.21	0.71	18.045	1.20	0.49	-42.312
3	1.14	0.68	22.702	1.14	0.46	-43.54
4	0.45	0.51	22.752	1.31	0.80	-33.121
5	0.75	0.90	24.634	1.45	0.55	-44.499
6	0.75	0.27	31.512	0.86	0.59	-34.749
7						
8						
9						
10						
Mean	0.98	0.68	25.023	1.24	0.56	-38.96

Table 20 Steering input expert group

Steering Input Expert Group							
Run	Time to S1 (Sec)	Angle at S1 (Degrees x 10)	Time to S3 (Sec)	Angle at S3 (Degrees x 10)	Time between S1 & S3 (Sec)	Time to S4 (Sec)	Time between S3 & S4 (Sec)
1	1.01	12.24	1.49	-35.54	0.48	2.24	0.75
2	0.72	10.73	1.20	-38.18	0.48	1.81	0.61
3	0.68	5.27	1.14	-43.54	0.46	1.88	0.74
4	0.41	5.99	1.00	-39.73	0.59	1.82	0.82
5	0.81	10.96	1.44	-46.79	0.63	2.37	0.93
6	0.30	17.10	0.71	-46.69	0.41	1.55	0.84
7							
8							
9							
10							
Mean	0.66	10.38	1.16	-47.75	0.51	1.95	0.78

Table 21 Lean angles expert group

Lean Angle Expert Group							
Run	Time to Max Angle L1 (Sec)	Max angle in L1 (Degrees)	Time to L2 (Sec)	Angle at L2 (Degrees)	Time to L4 (Sec)	Angle at L4 (Degrees)	Time between L2 & L4 (Sec)
1	0.37	4.68	1.39	-11.04	2.17	28.27	0.78
2	0.46	1.72	1.07	-9.34	1.74	25.69	0.67
3	0.09	0.81	1.05	-16.43	1.83	20.12	0.78
4			0.90	-16.50	1.66	19.91	0.76
5			1.31	-21.42	2.15	21.89	0.84
6			0.62	-19.83	1.39	22.39	0.77
7							
8							
9							
10							
Mean			1.57	15.76	1.82	23.05	0.77

Table 22 Yaw angle expert group

Yaw Angles Expert Group					
Run	Time to Y1 (Sec)	Angle at Y1 (Degrees)	Time to Y2 (Sec)	Angle at Y2 (Degrees)	Time between Y1 & Y2 (Sec)
1	1.21	-1.82	1.79	-15.58	0.58
2	0.88	-4.02	1.43	-17.45	0.55
3	0.88	0.34	1.40	-13.94	0.52
4	0.72	1.34	1.44	-10.58	0.72
5	1.08	1.91	1.69	-10.56	0.61
6	0.47	1.79	1.03	-13.17	0.56
7					
8					
9					
10					
Mean	0.87	1.87	1.46	13.55	0.59

Appendix 1

Ethier's feedback loop and error detector of the new steering theory.

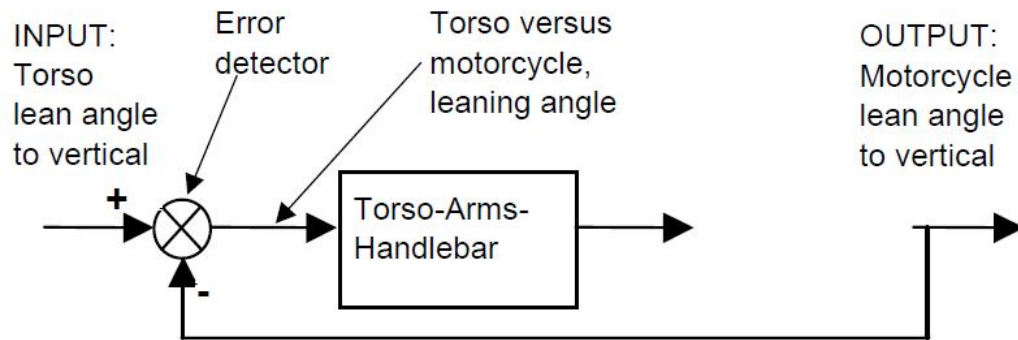

Appendix 2

Rider Skill Influences on Motorcycle Maneuvering (Rice, 1979)

Lane change test manoeuvre geometry

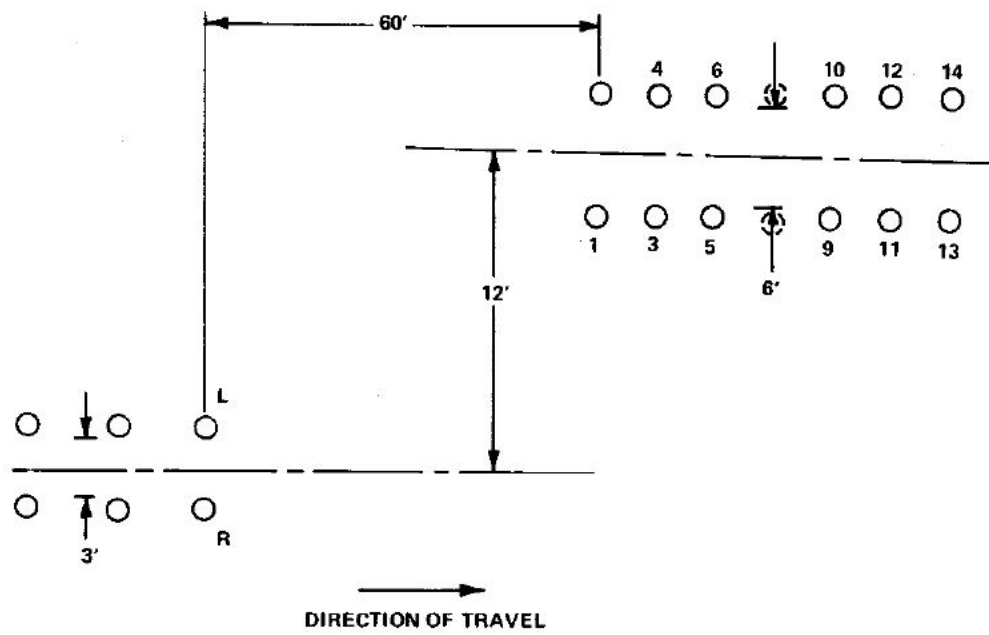

Appendix 3

Varat et al. (2004) Graph of the input and response of the touring motorcycle.

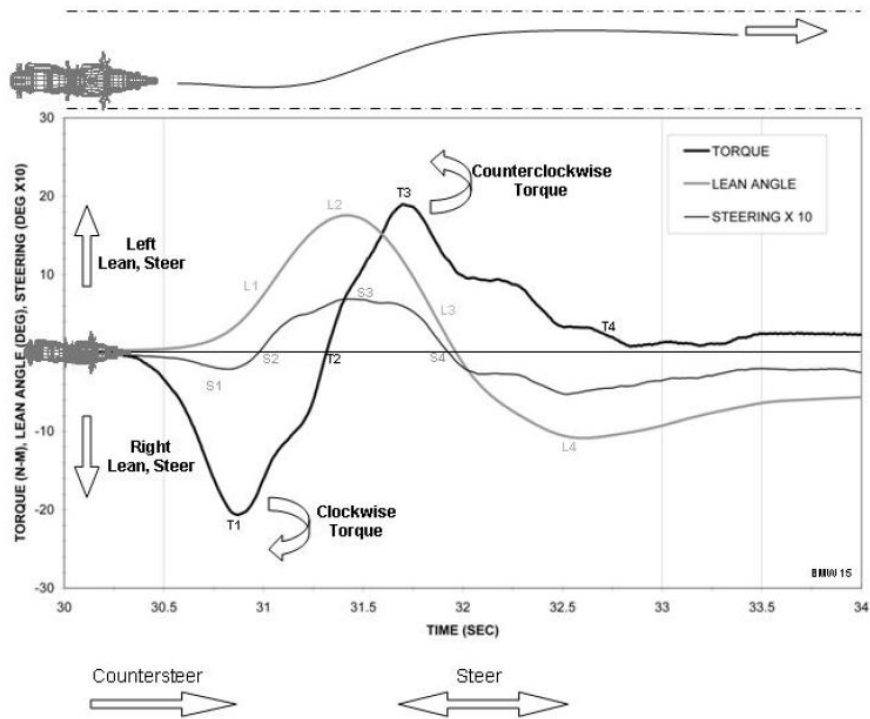

Graph of the input and response of the off road motorcycle.

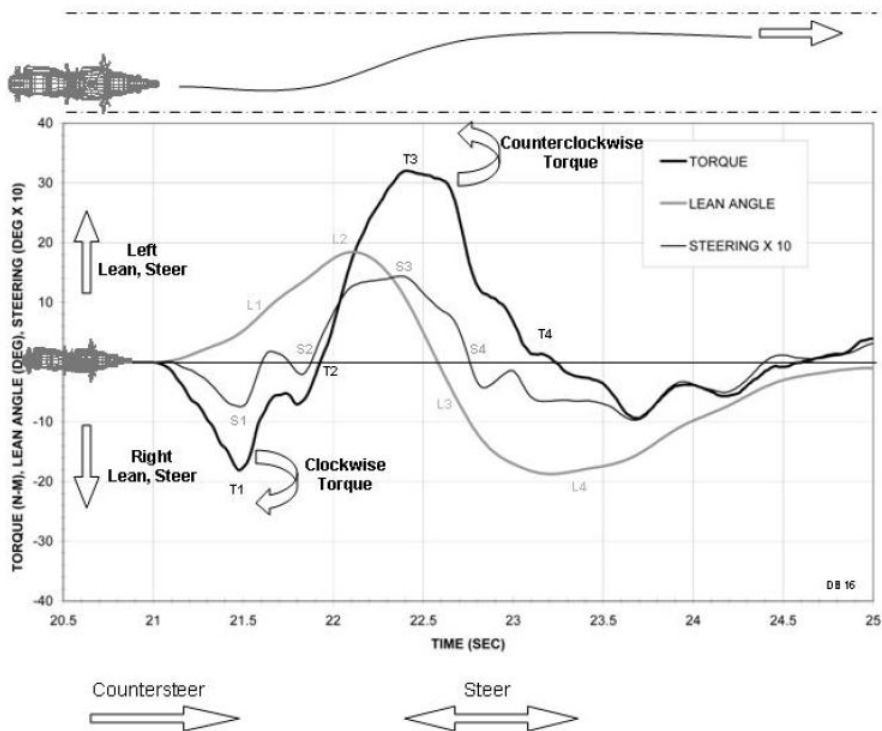

Graph of the input and response of the sports motorcycle.

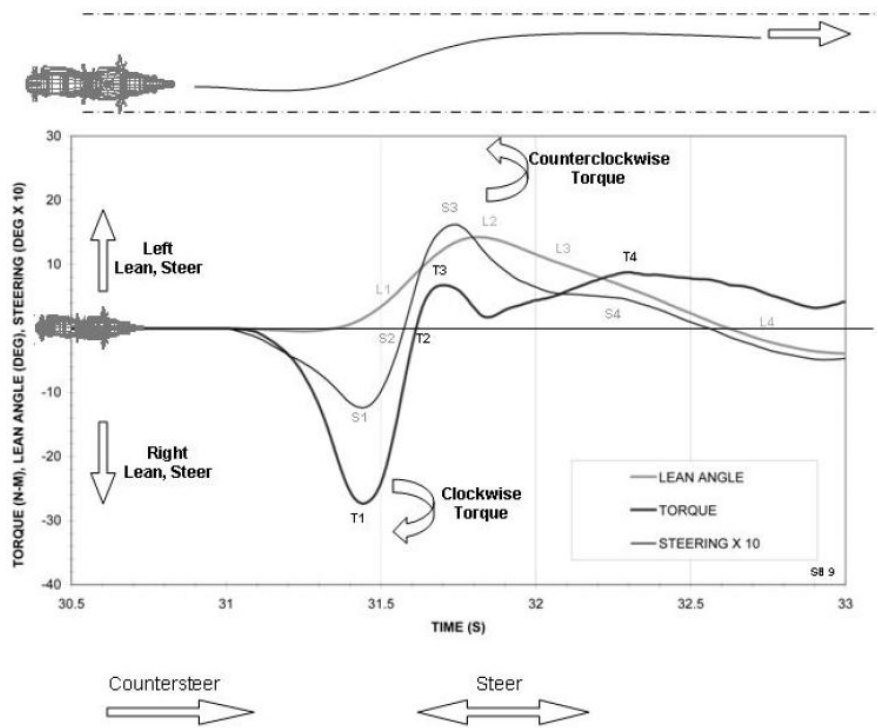

Appendix 4

Questionnaire

- 1 Gender Male
 Female

- 2 Area of residence UK
 North America
 Australasia
 France
 Germany
 Holland
 Italy
 Eire
 Spain
 South America
 Other

- 3 Age 16-29
 30-39
 40-49
 50-59
 60-69
 70+

- 4 How long have you held a motorcycle licence
 Under 5 yrs
 5-9
 10-19
 20-29
 30-39
 40-49
 50+

- 5 How did you qualify for your licence
 CBT/DOT test
 DOT test
 Direct access

- 6 What type of motorcycle do you ride
 Sports
 Sports tourer
 Tourer
 Classic
 Trials
 Scooter

- 7 What size is your machine
 49-250
 250-599
 600-999
 1000-1300
 Over 1300
- 8 Do you ride (a) Only on the road (b) On a track (c) Off road/green lane
 (a) only
 (b) only
 (c) only
 (a) + (b)
 (a) + (c)
 (b) + (c)
 (a) + (b) + (c)
- 9 What do you understand by the term countersteering? Is it
 Gyroscopic effect
 Specific frame design
 Different way of steering
 None of these
- 10 Does it allow you to
 Ride faster
 Corner more safely
 Avoidance technique
 None of these
- 11 Have you ever experienced a swerve to avoid collision
 Yes
 No
- 12 Have you been taught countersteering [If you answer NO to this question go to the end and submit form. Thank you]
 Yes
 No
- 13 What year did you undergo countersteering training
 Before 1960
 1960-1969
 1970-1979
 1980-1989
 1990-1999
 2000-2009
- 14 If you have been taught countersteering how were you taught
 During basic training
 During advanced training
 Specialist course

- 15 If you have been trained how long was your training
- ½ day
 - 1 day
 - 2 day
 - 3 day
 - 4 day
 - 5 day
- 16 have you experienced a swerve to avoid collision since being taught countersteering
- Yes
 - No
- 17 If you answered Yes to question 11 was this before or after being taught countersteering
- Before
 - After

Appendix 5

Genstat 5 Third Edition (Student Edition)
Genstat 5 Procedure Library Release PL10

```
3 "Data taken from File: C:\M346\DATA\SWERVE.GSH"
4
5 DELETE [redefine=yes] Count,Swerve,trained
6 VARIATE [nvalues=4] Count
7 READ Count
```

Identifier	Minimum	Mean	Maximum	Values	Missing
Count	32.00	68.50	101.00	4	0

```
9 FACTOR [modify=yes;nvalues=4;levels=2;labels=!t('No','Yes')] Swerve\
10 ; extra='Factor'
11 READ Swerve; frepresentation=ordinal
```

Identifier	Values	Missing	Levels
Swerve	4	0	2

```
13 FACTOR [modify=yes;nvalues=4;levels=2;labels=!t('No','Yes')] trained\
14 ; extra='factor'
15 READ trained; frepresentation=ordinal
```

Identifier	Values	Missing	Levels
trained	4	0	2

```
17
18 TABULATE [PRINT=totals; CLASSIFICATION=Swerve,trained; MARGINS=no] Count
```

	Total	
	No	Yes
trained		
Swerve		
No	101.00	51.00
Yes	90.00	32.00

```
19 TABULATE [PRINT=totals; CLASSIFICATION=Swerve,trained; MARGINS=no] Count;
TOTALS=toxtab
```

trained	toxtab	
	No	Yes
Swerve		
No	101.00	51.00
Yes	90.00	32.00

```
20 CHISQUARE [method=pearson] toxtab
```

Pearson chi-square value is 1.72 with 1 df.

Probability level (under null hypothesis) p = 0.190

```
21 CHISQUARE [method=maximumlikelihood] toxtab
```

Likelihood chi-square value is 1.73 with 1 df.

Probability level (under null hypothesis) p = 0.188

Appendix 6

1996 Kawasaki GT550 Motorcycle Specifications

PERFORMANCE

Maximum Horsepower	44.1 KW (60 PS) @ 10,000 r/min (rpm)
Maximum Torque	46.1 N-m (4.7kg-m, 34.0 ft-lb) @8,000 (rpm)
Minumium Turning Radius	2.5 m (98 in)

DIMENSIONS

Overall Length	2,230 mm (87.8 in)
Overall Width	755 mm (29.7 in)
Overall Height	1,100 mm (43.3 in)
Wheelbase	1,475 mm (58.1 in)
Road Clearance	155 mm (6.1 in)
Dry Weight	201 kg (443 lb)

ENGINE

Type	DOHC, 4-cylinder, 4-stroke, air-cooled
Displacement	553 mL (33.73 cu in)
Bore x Stroke	58.0 x 52.4 mm (2.28 x 2.06 in)
Compression Ratio	9.5 : 1
Starting System	Electric Starter
Cylinder Numbering Method	Left to right, 1-2-3-4
Firing Order	1-2-4-3
Carburetor	Keihin CV K30 x 4
Ignition System	Battery and coil (transistorized ignition)
Ignition Timing	12.5° BTDC @1,050 r/min (rpm)
(Electronically advanced)	40° BTDC @10,000 r/min (rpm)

Spark plugs	NGK D8EA or ND x24ES-U NGK DR8EWS or ND x24ESR-U
Lubrication System	Forced lubrication (wet sump)
Engine Oil	SE, SF or SG class SAE 10W40, 10W50, 20W40 or 20W50
Engine Oil Capacity	3.0 L (3.2 US qt)

TRANSMISSION

Transmission Type	6-speed, constant mesh, return shift
Clutch Type	Wet, multi disc
Driving System	Shaft drive
Primary Reduction Ratio	2.934 (27/23 x 65/26)
Final Reduction Ratio	2.522 (15/22 x 37/10)
Overall Drive Ratio	6.306 (Top gear)
Gear Ratio: 1 st	2.571 (36/14)
2 nd	1.777 (32/18)
3 rd	1.380 (29/21)
4 th	1.125 (27/24)
5 th	0.961 (25/26)
6 th	0.851 (23/27)

Final gear Case Oil	APL GL-5 (HYPOID GEAR OIL) SAE90 [above 5° (41°F) SAE80 [below 5° (41°F]
Final Gear Oil Capacity	190 ml (0.20 US qt)

FRAME

Castor	28°
Trail	107 mm (42.1 in)
Tire Size: Front	100/90-19 57H Tubeless
Rear	120/90-18 65H Tubeless

Fuel Tank Capacity 21.5L (5.7 US gal)

ELECTRICAL EQUIPMENT

Battery 12V12Ah

Headlight 12V 60/55W

Tail/Brake Light 12V 5/21W x 2

Turn Signal Light 12V 21W

Appendix 7

The Original Serpentine Test Course (To Scale)

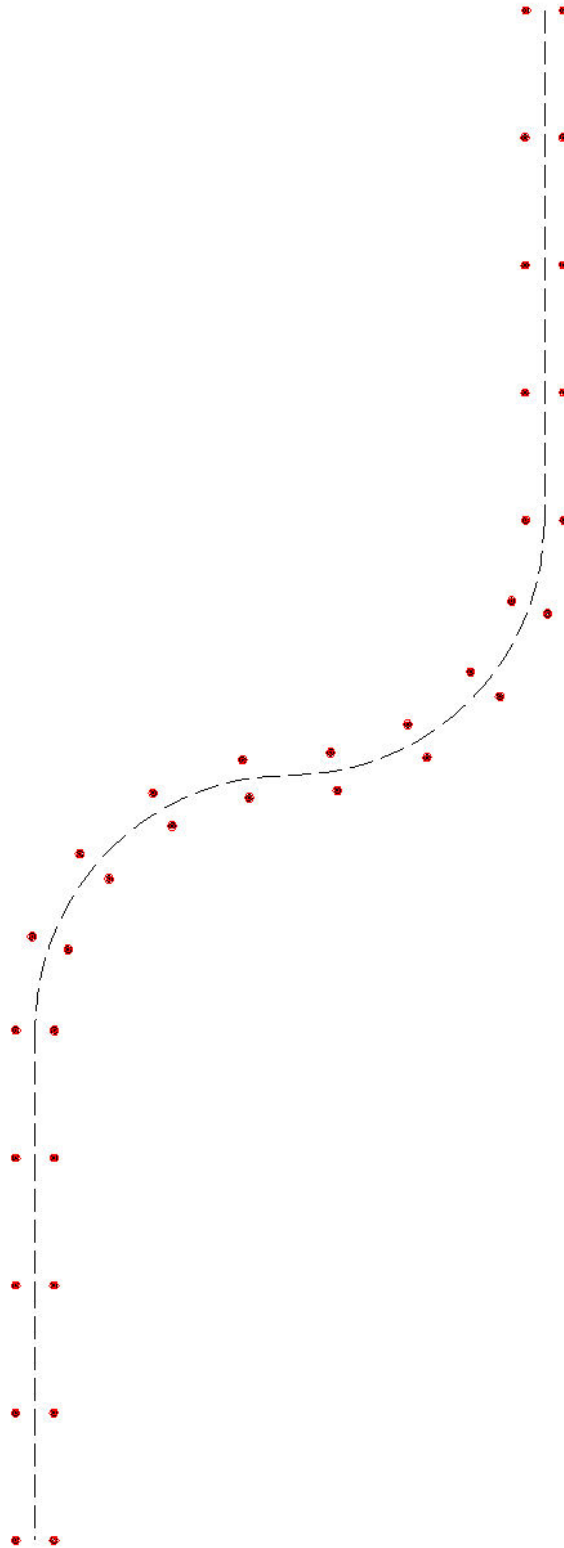

Appendix 8

Setting the standard in automotive testing



RT3000^{v2}

GNSS/INS for high dynamic vehicle testing

The RT3000 family of inertial navigation systems from Oxford Technical Solutions combine the best of GNSS positioning technology with high-grade gyros and accelerometers to deliver superior performance in a single enclosure.

>> Key features

- High speed GPS for dynamic conditions
- Up to 1 cm position accuracy
- 0.15° slip angle
- Multiple slip points
- High accuracy orientation
- Tightly coupled GNSS/INS
- Optional CAN acquisition
- OxTS gx/ix performance technology
- Driving robot interface
- 100 Hz data output rate
- Single or dual antenna
- GLONASS options
- Smooth, stable outputs
- Wheel speed input
- ITAR free
- ISO 17025 calibration available
- Software suite included

>> Applications

- Vehicle dynamics analysis
- Slip angle measurement
- Electronic stability control testing
- Tyre testing
- ADAS validation
- NHTSA regulation testing
- Electronic power steering testing
- Driving robot control
- And more...



>> Experts in GNSS and inertial technology

Advanced algorithms in the RT3000 seamlessly blend the inertial and GNSS data to provide smooth, robust, real-time outputs. Even in poor GNSS environments the RT3000 remains accurate with low latency outputs of position, acceleration, orientation and more. Now with OxTS gx/ix technology, we have improved position, velocity and orientation measurements making the performance even better than ever before.

>> One box, turnkey solution

Combining GNSS receivers, an inertial measurement unit, internal storage and a real-time on-board processor all in one compact box, the RT3000 delivers everything you need for a complete dynamics solution. The optional CAN acquisition upgrade eliminates the need for 3rd party acquisition systems making the RT3000 a true one-box solution for vehicle test engineers. All cables and antennas are included, and the RT3000 comes with an extensive software suite so you can post-process and plot your data at no additional cost.

>> Simple, flexible, reliable

With secure mounting options available and simple software wizards, installing and using the RT3000 is quick and easy. Data can be output at up to 100 Hz over Ethernet, serial or CAN in a range of formats. Packed with features to improve performance and functionality, including wheel speed input, driving robot interface, and heading lock, the RT3000 ensures reliable performance in all situations.

>> Worldwide standard

OxTS inertial navigation systems are recognised as a symbol of precision and performance around the globe. With a large number of systems in operation worldwide, you can be sure of the quality to expect from the RT3000. Now with ISO 17025 calibration available, our inertial measurements are traceable to national standards.

>> RT3000 v2 models

Standard	RT3100 v2	RT3102 v2	RT3002 v2	RT3003 v2
GLONASS enabled	RT3100G v2	RT3102G v2	RT3002G v2	RT3003G v2

>> Performance¹

Positioning	L1	L1	L1, L2	L1, L2
Position accuracy (CEP)				
SPS	1.8 m	1.8 m	1.5 m	1.5 m
SBAS	0.6 m	0.6 m	0.6 m	0.6 m
DGPS	0.4 m	0.4 m	0.4 m	0.4 m
RTK			0.01 m	0.01 m
Velocity accuracy (RMS)	0.1 km/h	0.1 km/h	0.05 km/h	0.05 km/h
Roll/pitch accuracy (1 σ)	0.05°	0.05°	0.03°	0.03°
Heading accuracy (1 σ) ²	0.1°	0.1°	0.1°	0.1°
Track angle accuracy (1 σ) ³	0.1°	0.1°	0.07°	0.07°
Slip angle accuracy (1 σ) ⁴	0.2°	0.2°	0.15°	0.15°
Dual antenna	x	✓	x	✓

>> Hardware

Dimensions	234 x 120 x 80 mm
Mass	2.2 kg (single antenna) 2.4 kg (dual antenna)
Input voltage	10–25 V dc
Power consumption	15 W (single antenna) 20 W (dual antenna)
Operating temperature	-10° to 50° C
Environmental protection	IP65
Vibration	0.1 g ² /Hz, 5–500 Hz
Shock survival	100 g, 11 ms
Internal storage	2 GB

>> Sensors

Type	Accelerometers	Gyros
Technology	Servo	MEMS
Range	10 g	100°/s
Optional	30 g	300°/s
Bias stability	2 μ g	2°/hr
Linearity	0.01%	0.05% ⁵
Scale factor	0.1%	0.1%
Random walk	0.005 m/s/ \sqrt hr	0.2°/ \sqrt hr
Axis alignment	<0.05°	<0.05°

¹ Valid for open sky conditions.

² Dual antenna heading valid for 2 m antenna separation. Wider separation will improve accuracy. Supports up to 5 m separation.

³ At 50 km/h.

⁴ With SuperAL adjustment.



Document version: 14,0613. Specifications subject to change without notice.



77 Heyford Park, Upper Heyford, Oxfordshire, OX25 5HD, UK
Tel: +44 1869 238 015 Email: sales@oxts.com Web: www.oxts.com



Appendix 9

Department of Transport Manoeuvring Area Layout and Dimensions

MMA Dimensions 3/4/08 13:30 Page 1

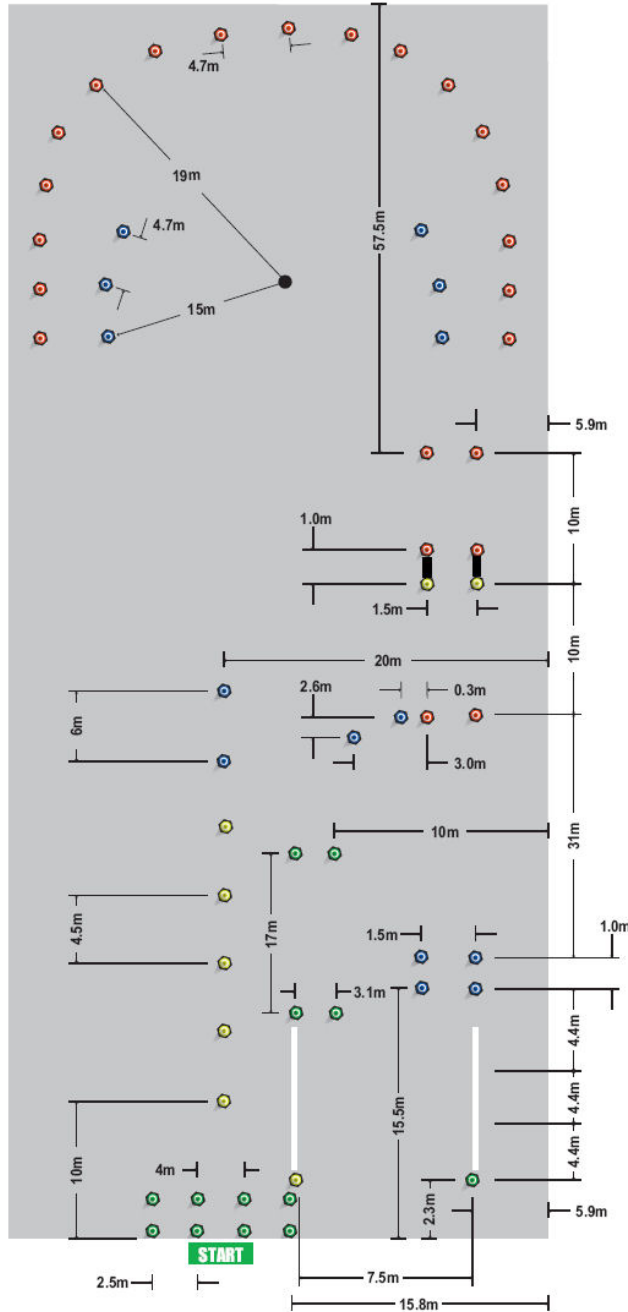

MOTORCYCLE MANOEUVRING AREA (MMA) DIMENSIONS (Right Circuit)

Marker Colour

- 29 x Red
- 20 x Blue
- 11 x Yellow
- 18 x Green

Total for Right and Left
Circuits = 78 Markers

March 2008

The design and its measurements
are based on a standard off-road
layout and may change due to
local conditions

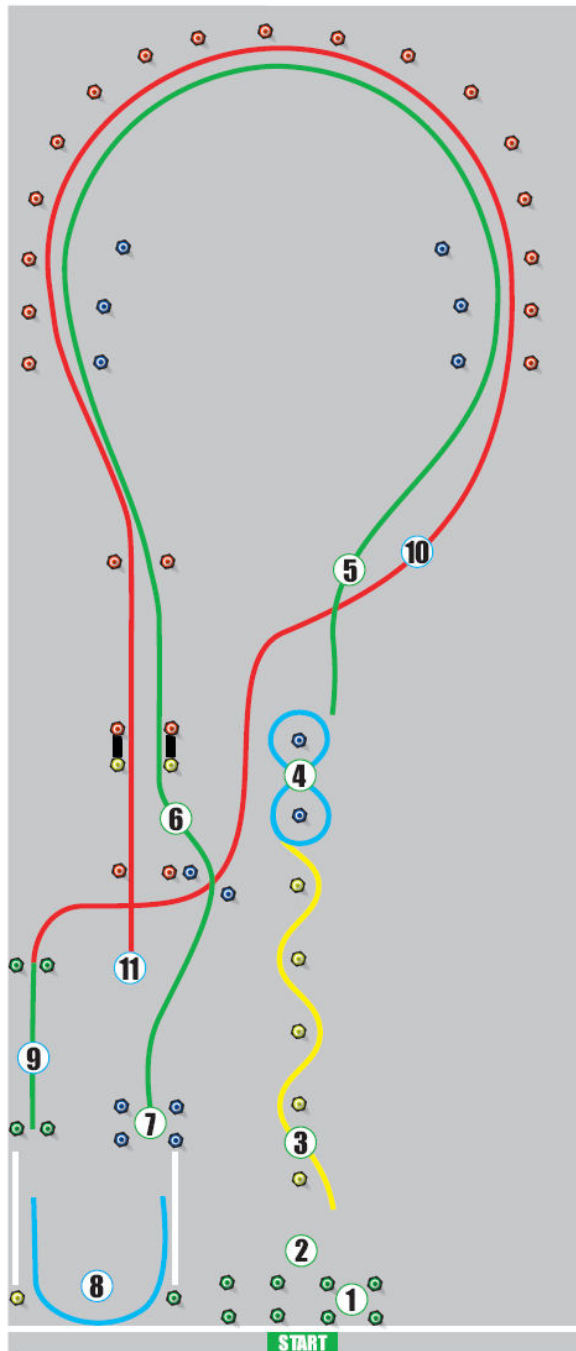

MOTORCYCLE MANOEUVRING Left Circuit

- 1 On and off the stand
- 2 Wheel the machine
- 3 Slalom
- 4 Figure of eight
- 5 30 kph / 19 mph circuit ride
- 6 50 kph / 32 mph avoidance
- 7 Controlled stop
- 8 U-turn
- 9 Slow ride
- 10 30 kph / 19 mph circuit ride
- 11 50 kph / 32 mph emergency brake

MOPEDS

For all mopeds, speed requirements are 30 kph / 19 mph

Diagram for illustrative purposes only.
For details of the circuit measurements,
please refer to the DSA Website.

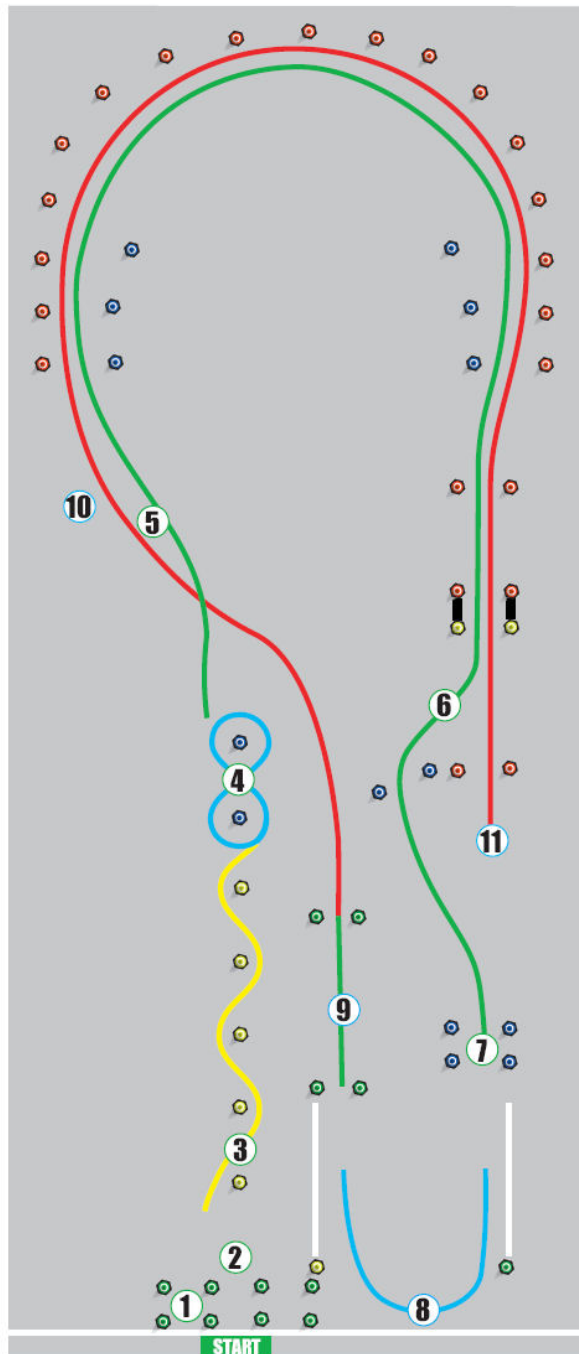

MOTORCYCLE MANOEUVRING Right Circuit

- 1** On and off the stand
- 2** Wheel the machine
- 3** Slalom
- 4** Figure of eight
- 5** 30 kph / 19 mph circuit ride
- 6** 50 kph / 32 mph avoidance
- 7** Controlled stop
- 8** U-turn
- 9** Slow ride
- 10** 30 kph / 19 mph circuit ride
- 11** 50 kph / 32 mph emergency brake

MOPEDS

For all mopeds, speed requirements are 30 kph / 19 mph

Diagram for illustrative purposes only.
For details of the circuit measurements,
please refer to the DSA Website.

Appendix 10

The modified DOT test course

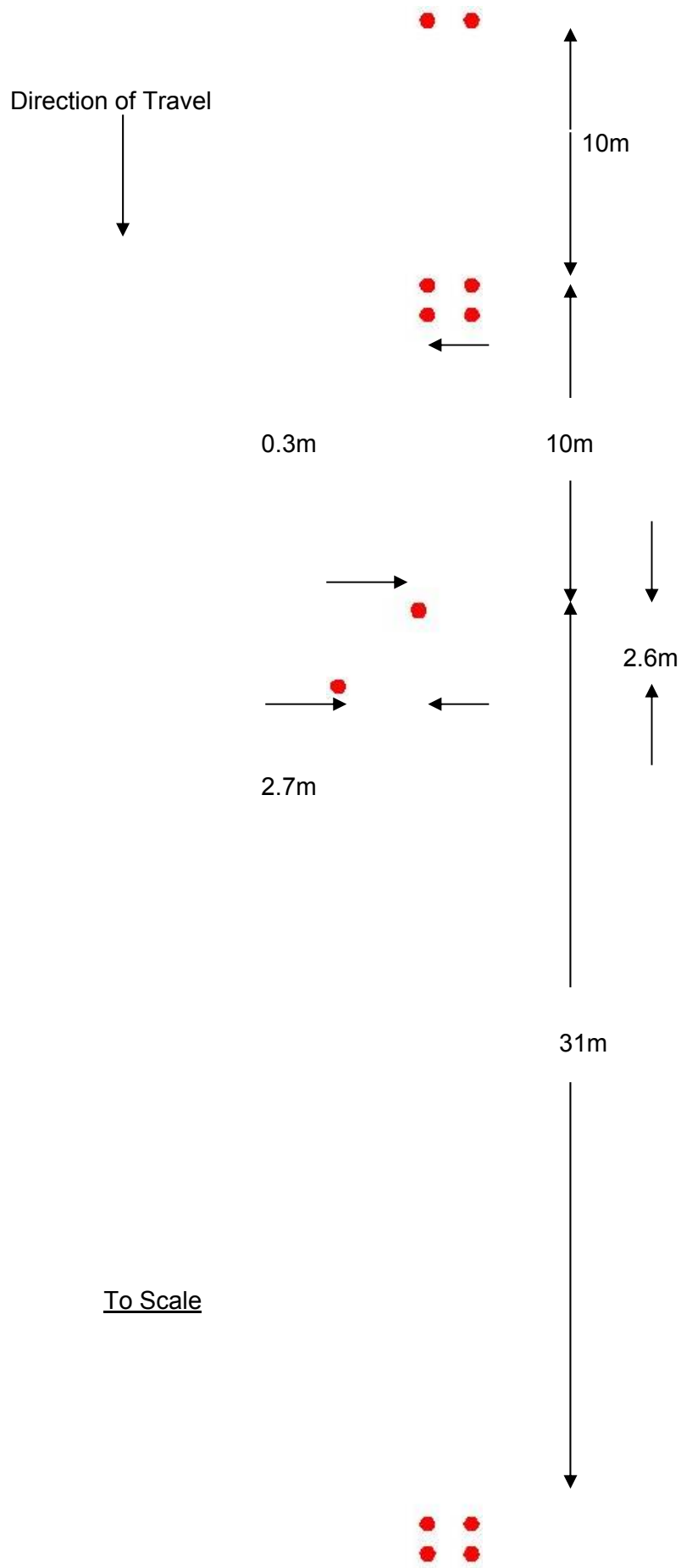

To Scale

Appendix 11

Technical Specification and Calibration Certificates for the Torque Transducer

MODEL: TQ-TRX



TRX—TORQUE TRANSDUCER



FEATURES

- Ratings 100—2000Nm
- Sealed to IP67.
- Accuracy $\pm 0.06\%$ FS.

APPLICATIONS

- Test Machines
- Process Control.

DESCRIPTION

The TQ-TRX provides a flange design device for measuring torsion. The TRX is produced from stainless steel construction and has a fully welded construction.

The load cell has been designed for test rig applications where static and dynamic measurement is required.

TYPICAL SPECIFICATION

PARAMETER	VALUE	UNITS
Static Torque	0.. 100, 250, 500, 1000, 2000	Nm
Rated Output	1 $\pm 0.1\%$	mV/V
Linearity & Hysteresis	0.06	$\pm\%$ of Rated Output
Zero Return after 30 minutes	0.03	$\pm\%$ of Applied Load
Zero Balance	± 0.5	%
Temperature Range: Operating	-10 to +70	$^{\circ}\text{C}$
Temperature Range: Compensated	0 to +60	
Temperature Effect: On Output	0.01	$\pm\%$ of FS
Temperature Effect: On zero	0.02	$\pm\%$ of FS
Safe Overload	120	% of Rated Capacity
Ultimate Overload	300	% of Rated Capacity
Excitation: Recommended	10	Volts DC
Excitation: Maximum	15	
Input Resistance	700 nom	Ohms
Output Resistance	700 nom	Ohms
Insulation Resistance	>2	G Ω at 50VDC
Deflection at Rated Capacity	NA	mm
Weight (approximate) :	NA	kg
Construction	Stainless Steel	
Environmental Protection	IP67	
Cable	5m 4 core screened	

Revision: MAY-08
Page 1

www.pcm-uk.com

MODEL: TQ-TRX



TRX—TORQUE TRANSDUCER

OUTLINE DIMENSIONS in millimeters

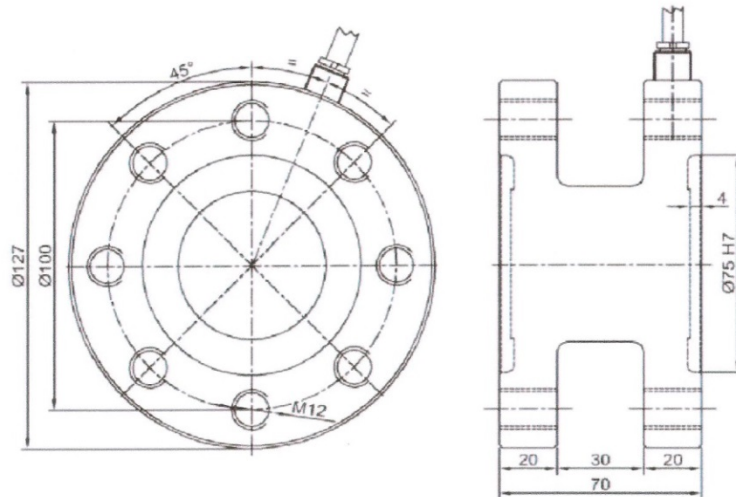

STATIC MAXIMUM LOAD	100 Nm	200 Nm	500 Nm	1000 Nm	2000 Nm
max axial permissible load	20 kN	40 kN	80 kN	150 kN	200 kN
breaking axial load	2 kN	4 kN	8 kN	15 kN	20 kN

FIXING SCREWS

A)	DIAMETER	M12
B)	GRADE	12.9
C)	TIGHTENING TORQUE	140Nm

NOTE: If the dimensions or specification do not suit, PCM have an in-house design and build service that should satisfy your requirements.

WIRING DETAIL

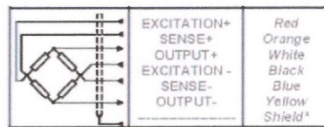

LOADING MODE



Revision: MAY-08
Page 2

Modifications reserved. All details describe our products in general form only. PCM assumes no liability whatsoever, and disclaims any express or implied warranty, relating to sales and/or use of PCM products including liability or warranties relating to fitness for a particular purpose.

www.pcm-uk.com
Email: sales@pcm-uk.com
Tel: +44 (0) 1926 864444
Fax: +44 (0) 1926 864888



PROCTER & CHESTER
(MEASUREMENTS) LTD
DALEHOUSE LANE
KENILWORTH
WARWICKSHIRE
CV8 2UE UK

TEL: +44 (0)1926 864444
FAX: +44 (0)1926 864888

EMAIL: sales@pcm-uk.com
WEBSITE: www.pcm-uk.com

CALIBRATION CERTIFICATE

GENERAL INFORMATION

CELL TYPE	TRX	RATED LOAD	100Nm
SERIAL NO.	711875	JOB NO.	18041
LOADING MODE	TORSION	CABLE LENGTH	5M

TEST RESULTS

TRUE ZERO +OR- (mV/V)	0.002	OUTPUT @ 1600Nm TORQUE	1.011
CAL EXCITATIONS (VOLTS)	5V	RESISTANCE TO GROUND (GOHMS)	>10
TEMP COMP RANGE (°C)	0 to +60°C	BRIDGE RESISTANCE (P+, P- OHMS)	701.0
TEMP COMP SHIFT (μV/V/°C)	< 0.1	BRIDGE RESISTANCE (S+, S- OHMS)	702.0

Cal.resistor N/A ohms shunted across P+/S+ ohm bridge gives N/A output.

BRIDGE WIRING

EXCITATION +	RED-PIN 3	SENSE +	ORANGE-PIN 2	OUTPUT +	WHITE-PIN 6
EXCITATION -	BLACK-PIN 5	SENSE -	BLUE-PIN 4	OUTPUT -	YELLOW-PIN 7

TESTED ON CALIBRATION EQUIPMENT No. TE 031

TESTED BY	J Stevens	DATE	23/08/2010
-----------	-----------	------	------------

QA APPROVED		DATE	23/08/2010
-------------	--	------	------------

CALIBRATION CERTIFICATE

LOADCELL TYPE:	TRX	LOADING MODE	CCW	JOB REF No.	18041
LOADCELL S.N.	711875	EXCITATION VOLTAGE - START (VDC)	INSTRUMENT		
DISPLAY TYPE:	ICA	EXCITATION VOLTAGE - END (VDC)	INSTRUMENT		
DISPLAY S.N.	1000508902	TEMPERATURE - (°C) START	24	SUPPLY VOLTAGE	12VDC
		TEMPERATURE - (°C) FINISH	24	TEST DATE	23/08/2010

LOAD APPLIED NM	% OF LOAD	1ST RUN VOLTS	2ND RUN VOLTS	3RD RUN VOLTS	AVERAGE VOLTS	ANALOGUE OUTPUT UNITS
0	0	2.485	2.487	2.485	2.486	2.486
20	20	1.917	1.917	1.918	1.917	1.917
40	40	1.434	1.433	1.434	1.434	1.434
60	60	0.950	0.949	0.950	0.950	0.950
80	80	0.468	0.468	0.463	0.466	0.466
100	100	0.066	0.067	0.066	0.066	0.066
0	0	2.487	2.488	2.485	2.487	2.487

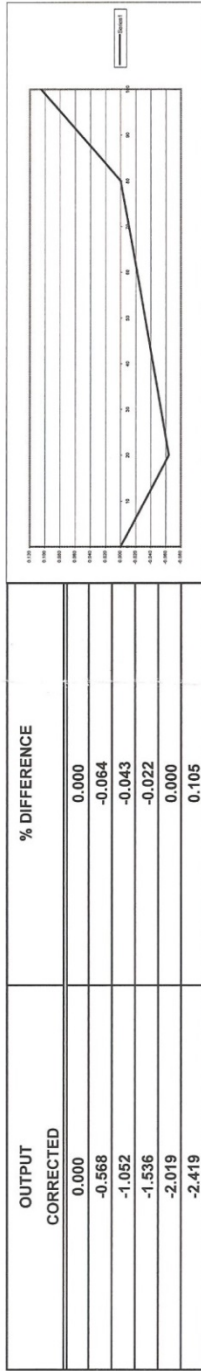

EXCITATION (P) +	RED-PIN 3	SENSE +	043	CERTIFICATE No.	25181
EXCITATION (P) -	BLACK-PIN 5	SENSE -	095	CERTIFICATE No.	300709
		ORANGE-PIN 2		OUTPUT (S) +	WHITE-PIN 6
		BLUE-PIN 4		OUTPUT (S) -	YELLOW-PIN 7



**PROCTER & CHESTER
(MEASUREMENTS) LTD**
DALEHOUSE LANE
KENILWORTH
WARWICKSHIRE
CV8 2JF UK

TEL: +44 (0)1926 864444
FAX: +44 (0)1926 864888
EMAIL: sales@pcm-uk.com
WEBSITE: www.pcm-uk.com

TESTED WITH FORCE TESTING EQUIPMENT NO. TE

TESTED WITH VOLTAGE MONITORING EQUIPMENT NO. TE

EQUIPMENT USED FOR THIS CALIBRATION HAS BEEN CERTIFIED USING NATIONAL STANDARDS

NO ELECTRICAL SAFETY CHECKS HAVE BEEN CARRIED OUT UNDER THIS CERTIFICATION

CHECKED BY: J Stevens APPROVED: [Signature] NAME: G CHESTER DATE: 24/08/2010

CALIBRATION CERTIFICATE

LOADCELL TYPE:	TRX	LOADING MODE	CW	JOB REF No.	18041
LOADCELL S.N.	711875	EXCITATION VOLTAGE - START (VDC)	INSTRUMENT		
DISPLAY TYPE:	ICA	EXCITATION VOLTAGE - END (VDC)	INSTRUMENT		
DISPLAY S.N.	1000508902	TEMPERATURE - (°C) START	24	SUPPLY VOLTAGE	12VDC
		TEMPERATURE - (°C) FINISH	24	TEST DATE	23/08/2010

LOAD APPLIED NM	% OF LOAD	1ST RUN VOLTS	2ND RUN VOLTS	3RD RUN VOLTS	AVERAGE VOLTS	ANALOGUE OUTPUT UNITS
0	0	2.485	2.481	2.482	2.483	
20	20	3.034	3.038	3.037	3.036	
40	40	3.513	3.512	3.513	3.513	
60	60	3.990	3.991	3.990	3.990	
80	80	4.465	4.464	4.464	4.464	
100	100	4.937	4.938	4.939	4.938	
0	0	2.482	2.483	2.482	2.482	

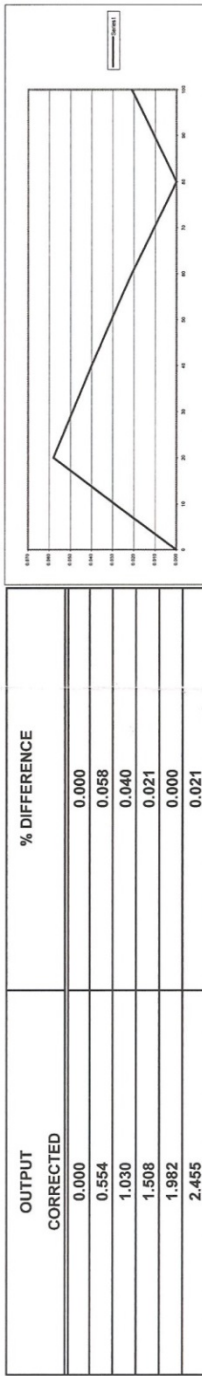

EXCITATION (P) +	RED-PIN 3	SENSE +	ORANGE-PIN 2	OUTPUT (S) +	WHITE-PIN 6
EXCITATION (P) -	BLACK-PIN 5	SENSE -	BLUE-PIN 4	OUTPUT (S) -	YELLOW-PIN 7

TESTED WITH FORCE TESTING EQUIPMENT NO. TE 031 CERTIFICATE No. TR8716

TESTED WITH VOLTAGE MONITORING EQUIPMENT NO. TE 095 CERTIFICATE No. 300709

EQUIPMENT USED FOR THIS CALIBRATION HAS BEEN CERTIFIED USING NATIONAL STANDARDS

NO ELECTRICAL SAFETY CHECKS HAVE BEEN CARRIED OUT UNDER THIS CERTIFICATION

CHECKED BY: J Stevens APPROVED: [Signature] NAME: G CHESTER DATE: 24/08/2010



**PROCTER & CHESTER
(MEASUREMENTS) LTD**
 DALEHOUSE LANE
 KENILWORTH
 WARWICKSHIRE
 CV8 2UE UK

TEL: +44 (0)1926 864444
 FAX: +44 (0)1926 864888
 EMAIL: sales@pcm-uk.com
 WEBSITE: www.pcm-uk.com

Appendix 12

Technical specifications of the Magnetic Angle Position Sensor



2D Debus & Diebold Meßsysteme GmbH, Alte Karlsruher Str. 8, D-76227 Karlsruhe
 Tel.: +49(0)721 94485-0 Fax.: +49(0)721 94485-29

SA-MAPxx-000

Magnetic angle position sensor

Features

- > Measures rotation angle / angle positions with very high resolution (e.g. steering position)
- > Low weight and small housing
- > Long operation time
ball bearings: >100x10⁶ cycles
- > Wide linear range
- > High resolution



Available with Deutsch connector

Options

- > To give a higher resolution, the sensor can be ordered with reduced measuring range down to min +5° / -5°. For more details see ordering information.

Technical specifications

Electrical characteristics		Mechanical characteristics	
Voltage supply.....	5 V	Dimensions (over all).....	Ø5 x 62 mm
Output voltage.....	0 - 5 V	Mounting rod.....	Ø 5 mm
Resistance range.....	0.5 to 10 Ω	Weight.....	45 g
Output range.....	± 5 °	Cable.....	
.....	± 10 °	type.....	Raychem EPD
.....	± 20 °	wire cross section.....	3 x AWG26
.....	± 30 °	length (standard).....	1200 mm
.....	± 40 °		
.....	± 50 °		
Range of linearity.....	max. ± 50 °		
Vibration resistance		Environmental data	
Vibration tested at.....	10 G	Ambient operating range.....	-25 to +80 °C
with a frequency of	@50 Hz	Humidity.....	5 to 95 %
		Sealing class.....	IP 65
Calibration		Ordering information	
Use the formulas on 2 nd page to calculate the physical values		Art.No.: Output range ± 5°..... SA-MAP05-000 Output range ± 10°..... SA-MAP10-000 Output range ± 20°..... SA-MAP20-000 Output range ± 30°..... SA-MAP30-000 Output range ± 40°..... SA-MAP40-000 Output range ± 50°..... SA-MAP50-000	

The specifications on this document are subject to change at 2D decision. 2D assumes no responsibility for any claims or damages arising out of the use of this document, or from the use of modules based on this document, including but not limited to claims or damages based on infringement of patents, copyrights or other intellectual property rights.

SA-MAPxx-000 **Magnetic angle position sensor**

Dimensions **Linear output voltage**

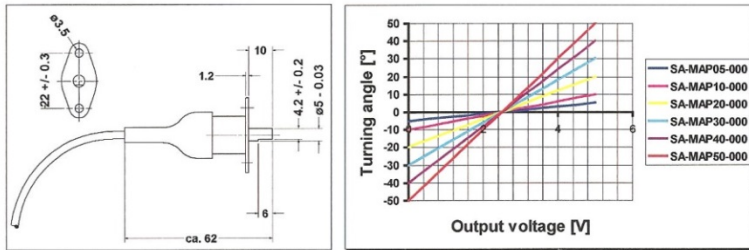

Formulas

	SA-MAPxx-000	Multiplicator	Offset
12 Bit A/D	Turning angle [°]	$2 \cdot xx / 4095$	* Digits - xx
16 Bit A/D	Turning angle [°]	$2 \cdot xx / 65535$	* Digits - xx
Voltage*	Turning angle [°]	2 4 8 12 16 20	* Volt - xx

SA-MAP05	SA-MAP10	SA-MAP20	SA-MAP30	SA-MAP40	SA-MAP50
----------	----------	----------	----------	----------	----------

Replace the xx with the turning angle of your sensor.
 → Possible values are 5, 10, 20, 30, 40 and 50° (other values on request)

Connector layout **Mating plug** **Connector at sensor**

Pin	Name	Description	Color (standard)	Color (alternative)
1	AGND	Analog Ground	black	or brown
2	+5V	Power supply	red	or white
3	n.c.	Not connected	-	-
4	n.c.	Not connected	-	-
5	Signal	Analog signal	white	or green

Pin	Deutsch 6-pin / male	Color
1	GND	black
2	+5V	red
3	-	-
4	-	-
5	Signal	white
6	-	-

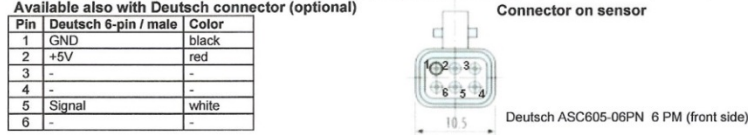

Optional available with open wires. Other options on customer request !

Please note:
 For the first order of special customer options please use the following order code: **SA-MAPxx-000**
 After the first order you will get from 2D a uniquely order code for your next orders.

Ordering information

Connector type	Order code	Remark
Standard: Binder 719,5PM	SA-MAPxx-000	xx = put in the range of the sensor type
Optional: Deutsch, 6PM	SA-MAPxx-001	xx = put in the range of the sensor type

The specifications on this document are subject to change at 2D decision. 2D assumes no responsibility for any claims or damages arising out of the use of this document, or from the use of modules based on this document, including but not limited to claims or damages based on infringement of patents, copyrights or other intellectual property rights.

2D Debus & Diebold Meßsysteme GmbH
<http://www.2D-daterecording.com>
<http://www.2D-Kit-System.com>
mail@2D-daterecording.com

Appendix 13

Horizon Angular rate Sensor Specifications





Horizon User's Guide



MEMS Angular Rate Sensor
Model Horizon (HZ1)

Sales and Customer Service
Systron Donner Inertial

Telephone: (925) 979 - 4500 Monday through Friday
Fax: (925) 979 - 9827 7:00 am to 4:00 pm PST
E-mail: sales@systron.com Website: www.systron.com



Horizon (HZ1) Manual 964013 Rev. A Page 1 of 5

RELEASED DOCUMENT
DATE: 08-06-07

SAFETY AND HANDLING INFORMATION

- **DO NOT DROP!** The Horizon is a precision instrument. Excessive shock can adversely affect sensor performance.
- Avoid exposing the Horizon to electrostatic discharge (ESD). Observe proper grounding while handling.
- Insure that power leads are installed properly before applying power to the Horizon.

PATENT INFORMATION

The Horizon is protected by the following patents: U.S. 4,654,663; U.S. 4,524,619; U.S. 4,899,587; U.S. Re. 33,479, plus other U.S. and foreign patents pending.

INSTALLATION

A. Connector Assembly

1. The Mating Connector (AMP MTA-100 OR MOLEX 2695) packaged with the Horizon comes unassembled so that you can customize the wire lengths to your particular installation.
2. Cut 26 gauge insulated wire (stranded). Allow 2-4" beyond what you think you'll need to provide strain relief in your wire routing. Strip 1/4" insulation from the end of each wire. Pre-tin, clean and trim off the excess. Proper wire preparation is the key to a good solder bond; a clean soldering iron tip will insure an uncontaminated solder joint.
3. Install each wire into the connector termination and crimp wire into place with needlenose pliers. Make sure there is a good mechanical connection. Solder wires using a small-tipped 650-700° F iron for 3-5 seconds.
4. Check **Table 1** for correct pin assignment. Insert each pin into the correct hole of the mating connector housing. Secure the wire bundle with lacing or zip cable about every 3". Do not over-tighten the lacing. Insure that there is no stress on the wire terminations at either end.

Table 1. Connector Pin Wiring Assignments

Connector Pin	HZ1-90-100A	HZ1-100-100	HZ1-200-100
1	+ 8 to + 15 VDC Input	+ 8 to + 15 VDC Input	+ 8 to + 15 VDC Input
2	Rate Output	Rate Output	Rate Output
3	Ref. Voltage +2.5 Vdc	Ref. Voltage +2.5 Vdc	Ref. Voltage +2.5 Vdc
4	No connection, leave open	No connection, leave open	No connection, leave open
5	Power & Signal Ground	Power & Signal Ground	Power & Signal Ground

Figure 1. Connection Diagram for Model Horizon

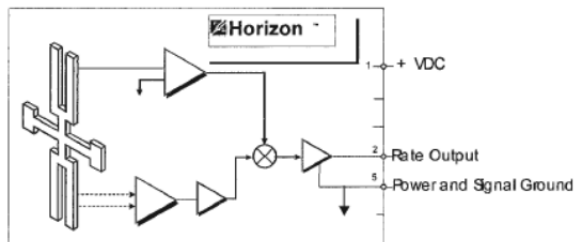

A. Mounting

1. Prepare the mounting surface. It should be sturdy and rigid, and must be flat within 0.005 inches. If the mounting surface flexes or vibrates, the Horizon will respond to the movement as an input.
2. Mount the Horizon using two small flat washers and 4-40 UNC screws or equivalent. The maximum mounting screw penetration is 0.20". Refer to **Figure 2** for location of tapped mounting holes. *Note that the sensitive axis orientation is parallel to the mounting surface.* Refer to SDI Horizon outline drawing number 962987.
3. Tighten screws to 5 in-lbs of torque for mounting. Over-torquing may damage the case or strip the threads.

B. Connection

1. *Verify power supply polarity before connecting the Horizon. The instrument's internal electronics are NOT protected against reverse-polarity power.*
2. Connect the wires, referring to **Figure 1**, **Figure 2** and **Table 1**. Note the different pin designations associated with each model.
3. Connect the power ground to the common (ground) of the power supply. Signal ground is common to power ground in the design. There is an internal jumper between signal ground and power ground. Power Ground is also tied internally to the case (optional on the 100C).
4. Minimize impedance of the supply power lines at the sensor. If you are using cables longer than three feet (3'), it is recommended to use solid tantalum bypass capacitor (10 μ f or more). Place the capacitors between the power line and ground within 6" of the terminals on the rate sensor.
5. Shield power input lines if you are operating the Horizon in the presence of high levels of electromagnetic interference (EMI). Sources of EMI include switching power supplies and radio transmitters.
6. Insert a presampling filter when using an analog-to-digital (A-D) converter with the Horizon. Set the bandwidth of the presampling filter at 1/4 to 1/3 of the sampling frequency.

OPERATION AND TROUBLESHOOTING

When properly installed and connected, the Horizon should meet or exceed the specifications listed on **Table 2**. If you do not achieve this level of performance when operating your Horizon, one of the following suggestions should resolve the problem. If not, please prepare a summary of your findings and call an Applications Engineer at Systron Donner Inertial: 866-BEI-GYRO (866-234-4976), Monday through Friday, 7:00-4:00 PST.

A. Bias Not In Specification

1. *Structural Vibrations or Mounting Surface Movements.* The Horizon responds to very small angular rates. Observed voltage outputs, thought to be noise or bias, may result from real input motions caused by structural vibrations or mounting surface movements. Test the Horizon with all potential vibration sources shut off and compare performance with previous results. Alternatively, move the Horizon to a different mounting location or change the sensitive axis direction.
2. *Bias Shifts Caused by Ground Loops.* Ground loops may cause a bias shift that affects instrument performance. Check the wiring layout for ground loops.

3. *Crosstalk Between Horizon Units.* Two or more Horizon units directly connected from the same power supply can possibly crosstalk, increasing bias or noise generation for each unit. First, eliminate power supplies as a cause of crosstalk (see #4 below). Then, test a single Horizon after disconnecting all others. If the noise or bias decreases, consider electrical isolation using an R-C Pi filter network on each of the power lines to the individual Horizon instruments.
4. *Switching Power Supplies.* Some switching power supplies may cause a bias or noise increase in the output of the Horizon. Run one Horizon from a quality bench linear power supply, such as a Lambda Model LQD 422, or from a set of batteries, to see if the switching power supplies are the problem. If the bias/noise decreases, put a 100 uf capacitor and a 0.1µf ceramic bypass capacitor between the power supply lines and ground within 6" of the Horizon before reconnecting the switching power supplies.

C. Output Tone at 340 Hz

Under certain conditions of shock and/or vibration, the Horizon can emit a narrow-bandwidth tone in the region of 340 Hz (± 20 Hz). This tone is usually not observable in output signals, because the sensor has an approximate corner frequency of 18 Hz or 50 Hz (depending on model) with a signal rolloff of -12 dB per octave. If the tone becomes significant in your application, an appropriate filter may be used.

D. Technical Assistance

We want you to be thoroughly satisfied with our product. If you have questions or need assistance in operating your Horizon, please call us. You can reach an Applications Engineer at Systron Donner Inertial by calling 866-BEI-GYRO (866-234-4976).

FIGURE 2 Horizon Outline Details

Outline dimensions are in inches.
Dimensions in brackets are in [millimeters].

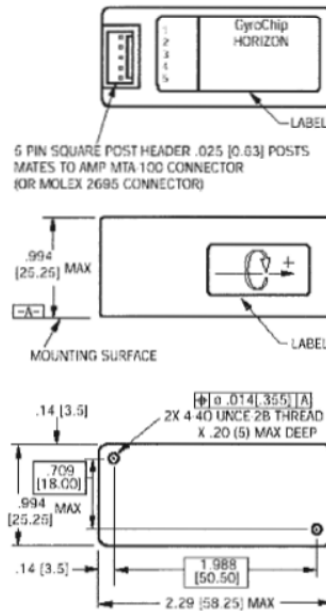

Table 2. Horizon Specifications

Power Requirements	HZ1-90-100A	HZ1-100-100	HZ1-200-100
Input Supply Voltage	+8 to +15 VDC	+8 to +15 VDC	+8 to +15 VDC
Input Supply Current (max)	< 20 mA	< 20 mA	< 20 mA
Performance			
Range	±90°/sec	±100°/sec	±200°/sec
Full Scale Output	+0.5 Vdc (-FS) to +4.5 Vdc (+FS)		
Scale Factor (±2%)	22.2 mV/°/sec	20.0 mV/°/sec	10.0 mV/°/sec
S.F. Over Operating Temperature (Deviation from 22 °C)	< 0.08%/°C	< 0.08%/°C	< 0.08%/°C
Bias (Initial offset at 22 °C)	+2.5 ±0.045VDC	+2.5 ±0.045VDC	+2.5 ±0.045VDC
Bias Stability			
Long-term (one year)	< 1.0°/sec	< 1.0°/sec	< 1.0°/sec
Over Operating Environments (Deviation from 22 °C)	< 4.5°/sec	< 4.5°/sec	< 4.5°/sec
g Sensitivity (all axes)	< 0.06°/sec/g	< 0.06°/sec/g	< 0.06°/sec/g
Linearity Error	< 0.05% of F.R	< 0.05% of F.R	< 0.05% of F.R
Output Noise (to 100 Hz)	< 0.025°/sec/√Hz	< 0.025°/sec/√Hz	< 0.025°/sec/√Hz
Bandwidth (-90° Phase shift)	> 18 Hz	> 60 Hz	> 60 Hz
Resolution and Threshold	< 0.004°/sec	< 0.004°/sec	< 0.004°/sec
Start-up time	< 1.0 sec	< 1.0 sec	< 1.0 sec
Environments			
Operating Temperature	-40° C to +71° C	-40° C to +71° C	-40° C to +71° C
Storage Temperature	-55° C to +100° C		
Vibration Operating	2 g _{rms} 20 to 2K Hz random		
Vibration Survival	10 g _{rms} 20 to 2K Hz random, 5 min/axis		
Shock	200 g pk, 2 ms, ½ sine		
Weight	< 60 grams		

CONTACT INFORMATION

Systron Donner Inertial

355 Lennon Lane · Walnut Creek, California 94598



Customer Service: PH: 925-979-4500 · FAX: 925-979-9827
 Sales and Technical Support: 866-BEI-GYRO (866-234-4976)
 E-Mail: sales@systron.com · Web Site: www.systron.com

European Business Office: ++44 (0) 1227 776460 · FAX: ++44 (0) 1227 363289
 E-Mail: bei.tech@ukonline.co.uk

Appendix 14

Vericom VC4000 Technical Specification

Vericom VC4000DAQ Performance Computer
New! internal 10Hz GPS and automatic pitch adjustment





2G to 100G
1 to 1000 Hz

Super easy to install and completely portable, single suction cup with ram mount, self leveling.

Over 25 years of research and development have gone into the design of the Vericom VC4000DAQ making it the most innovative instrument for measuring tire to road friction and vehicle performance. Vericom's reputation for excellence is truly displayed within the workings for the VC4000DAQ. Vericom is known world-wide for its accuracy in calculating vehicle speed and distance from acceleration and time. Vericom is the only performance computer in its price range that can accurately synchronize acceleration, speed, time and distance during vehicle braking which is partially due to Vericom's RDP™ (Run Duration Protocol). Now with OBDII interface and built-in 10 Hz GPS the VC4000DAQ is its own working test module allowing the Vericom's speed to be easily confirmed.

New tri axis 2G to 6G accelerometer up to 1000 Hz sample rate. Infinite storage time.



Pitch

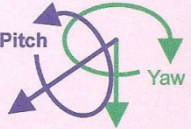

Internal 2 axis angular rate gyro for measuring yaw and automatic pitch adjustment

Yaw

360° magnetometer (compass) built-in.



10Hz GPS Built-in

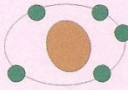

PC Communications by

- ⇒ USB port.
- ⇒ Bluetooth up to 100 meters.
- ⇒ SD card & 3ea RS232 ports.
- ⇒ Streaming data.

- OBDII & CAN input.
- Firmware & software updates from internet.
- Simple calibration check.
- Up to 16 sensors input.
 - * Brake pedal force sensor.
 - * 10G to 100G accelerometers.
 - * Pressure sensors.
 - * 4 RPM sensors.
- Crash mode for high or low speed impact testing.
- Resolution 16 bits.
- Bandwidth 2,469 Hz.
- Windows compatible including XP/Vista/™7™.
- Up to 116 minutes of data storage before using SD card.
- Analog output.

System requirements

- 100MB hard drive space.
- 512MB RAM.
- 1.0 GHz or faster processor.

Comes with **Profile Professional 5©** software a powerful graphic software that allows the user to graph, overlay, table, display and store the data. You can easily analyze and compare information using the preprogrammed graphs and tables, or design your own reports and graphs for presentations and courtroom testifying. More **Sensor ports**, up to 18 sensors using the quick connect plug and play feature may be easily installed. Profile© will support all 16 sensors including 4 tachometer inputs, GPS and OBDII. One **Analog output port** is available to connect a sensor to another data acquisition system. **Firmware** (the software that runs the Vericom) is a menu select format and all upgrades can be made from the internet. Simple **calibration check** procedures are displayed on the screen with step by step instructions. **PC interface** has been upgraded from USB & RS232 to include Bluetooth, SD flash memory card and streaming data for unlimited memory. **Streaming data**, use your laptop for infinite storage and monitoring of data in real time. Display all sensors using analog meter in real time on your laptop. **Bluetooth** communications allows you to upload data to your PC 100 meters away.

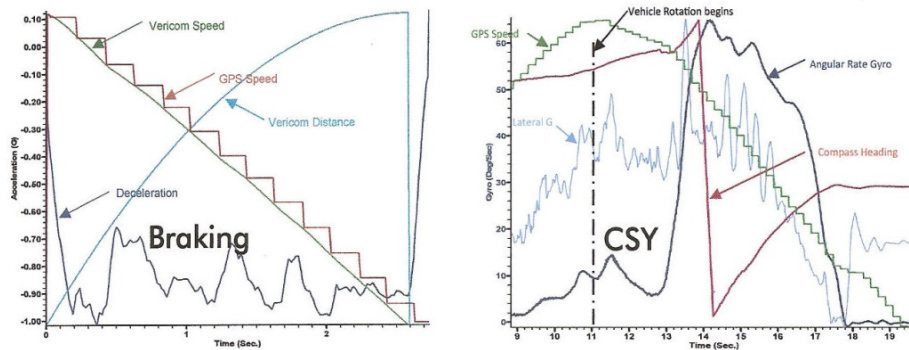

Formulas for calculating vehicle speed have included an acceptable range table to aid in courtroom presentations.

Display Average Table 2/18/2008					
Date & Time	Run No.	Time Sec	Acceleration Average G	Speed MPH	Distance Feet
9/24/2002 09:18 AM	4	1.95	-0.891	38.10	56.6
9/24/2002 09:19 AM	5	1.95	-0.887	37.95	55.8
9/24/2002 09:21 AM	6	1.95	-0.882	37.74	56.2
9/24/2002 09:22 AM	7	3.46	-0.897	68.07	178.5
9/24/2002 09:23 AM	8	3.41	-0.897	67.06	172.4
9/24/2002 09:25 AM	9	3.35	-0.895	65.74	168.4
9/24/2002 09:27 AM	10	4.13	-0.892	80.80	253.4
Average of Runs		2.89	-0.891	56.50	134.5

Range Table	
f	Speed Result
0.80	57.88
0.81	58.24
0.81	58.60
0.83	58.96
0.84	59.31
0.85	59.66
0.86	60.01
0.87	60.36
0.88	60.71

Vericom Computers, Inc

Phone 763-428-1381 USA or Canada 800-533-5547 fax 763-428-4856
 info@vericomcomputers.com www.vericomcomputers.com
 14320 James Road - Suite 200 - Rogers, MN 55374

Appendix 15

SENSORS FITTED TO TEST MOTORCYCLE				
Number	Monitoring	Sensor	Location	Calibration
1	X acceleration	±2G MEMS	VC4000	Zero set
2	Y acceleration	±2G MEMS	VC4000	Zero set
3	Z acceleration	±2G MEMS	VC4000	Zero set
4	Steering angle	SA-MAP20-000	Lower steering yolk	Zero set
5	Steering rate	HZ1-90-100A	Upper steering yolk	Zero set
6	Steering torque	TQ-TRX100Nm	Handlebars	Torsion
7	Roll rate	HZ1-90-100A	Above rear wheel	Zero set
8	Clutch	Relay	Clutch lever switch	n/a
9	Front brake	Relay	Hand brake lever switch	n/a
10	Rear brake	Relay	Foot brake switch	n/a
11	Engine speed	Tachometer	Ignition system	n/a

Notes:

The technical specification of the VC4000DAQ and all the individual sensors can be seen at the respective appendices.

Calibration. All sensors are calibrated at manufacture with the exception of the TQ-TRX.

Zero set. A control within the VC4000 DAQ which allows designated sensors to be set to zero at the start of the test run.

Torsion. The method used to calibrate the TQ-TRX sensor. The torsion is increased in 20Nm intervals to a maximum and the output voltage is recorded at each increment.

Tachometer The VC4000DAQ accepts inputs directly from the motorcycle ignition system.