

## A 160 kJ dual plasma focus (DuPF) for fusion-relevant materials testing and nano-materials fabrication

S. H. Saw

*INTI International University, 71800 Nilai, Malaysia  
Institute for Plasma Focus Studies, 32 Oakpark Drive, Chadstone, 3148 Australia  
sorheoh.saw@newinti.edu.my*

V. Damideh

*INTI International University, 71800 Nilai, Malaysia  
v\_damideh@yahoo.com*

P. L. Chong

*INTI International University, 71800 Nilai, Malaysia  
perklin.chong@newinti.edu.my*

P. Lee

*National Institute of Education, Nanyang Technological University, Singapore  
paul.lee@nie.edu.sg*

R. S. Rawat

*National Institute of Education, Nanyang Technological University, Singapore  
rsrawat@nie.edu.sg*

S. Lee

*INTI International University, 71800 Nilai, Malaysia  
Institute for Plasma Focus Studies, 32 Oakpark Drive, Chadstone, 3148 Australia  
Physics Department, University of Malaya, Kuala Lumpur, Malaysia  
leesing@optusnet.com.au*

Published 13 August 2014

This paper summarizes PF-160 Dual Plasma Focus (DuPF) numerical experiments using the Lee Model code and preliminary 3D design drawings using SolidWorks software. This DuPF consists of two interchangeable electrodes enabling it to be optimized for both Slow Pinch Mode (SFM) and Fast Pinch Mode (FFM); the latter using a speed factor (SF) of 90 kA cm<sup>-1</sup> Torr<sup>-0.5</sup> for FFM in deuterium [S Lee et al, IEEE Trans Plasma Science 24, 1101-1105 (1996)]; and the former with SF of less than half that value for SFM. Starting with available 6 x 450 μF capacitors rated at 11kV (10% reversal), numerical experiments indicate safe operation at 9 kV, 6 Torr deuterium with FFM anode of 5 cm radius; producing intense ion beam and streaming plasma pulses which would be useful for studies of potential fusion reactor wall materials. On the other hand operating at 5 kV, 10 Torr deuterium with SFM anode of 10 cm radius leads to long- duration, uniform large-area flow which could be more suitable for synthesis of nano-materials. The dual plasma focus design is illustrated here with two figures showing FFM and SFM electrodes.

This is an Open Access article published by World Scientific Publishing Company. It is distributed under the terms of the Creative Commons Attribution 3.0 (CC-BY) License. Further distribution of this work is permitted, provided the original work is properly cited.

*Keywords:* Dual Plasma Focus, Lee Model, speed parameter, slow focus, fusion materials, nano-materials.

## 1. Introduction

For many years, tremendous efforts towards the achievement of controlled thermonuclear fusion have been channeled to the study of powerful electrical discharges which in deuterium plasma pinches led to the detection of neutron emission. The total flux of neutrons was found to vary with the pressure, gas purity and discharge current.<sup>1</sup> The plasma focus is one of the low-cost and portable pulsed fusion devices which typically operates with an axial acceleration phase, followed by a fast radial compression and an intense pinch and explosive pinch disruption phase (the Fast Focus Mode, FFM). During these two last phases intense radiations are emitted including x-rays and powerful axially directed beams of ions and electrons. The break-up of the pinch also launches axially propagating fast plasma streams. The intense multi-radiations have many applications including fusion neutron generation, testing of potential wall materials in fusion-relevant situations and fabrication and deposition of advanced materials.

The DPF facility as a plasma accelerator produces hot ( $T_{pl} \sim 1$  keV) fast ( $v_{pl} > 10^7$  cm/s) dense ( $n_{pl} \approx 10^{16}$  to  $10^{19}$  cm<sup>-3</sup>) plasma streams, high energy ion ( $E_i \approx 0.01$  to 100 MeV) and electron ( $E_e \approx 0.01$  to 1.0 MeV) beams in addition to soft ( $E_{hv} \sim 0.1$  to 10 keV) and hard ( $E_{hv} \sim 10$  to 1000 keV) X rays and fusion neutrons ( $E_n \sim 2.45$  and 14 MeV).<sup>2</sup>

More recently it has become apparent that for the purpose of materials deposition and fabrication of nano-materials, the intensity of the radiation and beams may need to be controlled. It has been suggested that the elimination of charged particle beams may be beneficial overall for the deposition of certain nano-materials. Thus the reduction of the intensity of the pinch or even the elimination of the pinch sub-phase may be of use for deposition especially from the point of view of homogeneity.<sup>3</sup> This gives rise to the concept of the Slow Focus Mode (SFM).

The ZaP Flow Z-Pinch Experiment at the University of Washington investigates the stabilization effects of sheared flows on an otherwise unstable plasma configuration. The experiment generates flow Z-pinches that are stable for 2000 times longer than predicted by static plasma theory. Two coaxial electrodes are contained inside a vacuum tank. Gas is puffed into the annulus between the electrodes and expands for around 1 ms. A voltage ranging from 2 -10 kV is applied across the two electrodes by an external capacitor bank to ionize the gas and conduct a plasma current. The magnetic field generated by the current creates a  $\mathbf{J} \times \mathbf{B}$  Lorentz force that accelerates the plasma. The current sheet collapses to the end of the inner electrode and continues to be accelerated until the plasma collapses on axis to form a Z- pinch column.<sup>4</sup> In this way a long duration plasma flow is achieved in the ZaP.

Numerical results of FFM and SFM in this research have been achieved by Lee Code. The model in its two-phase form was described in 1984.<sup>5</sup> It was used to assist in the design and interpretation of several experiments.<sup>5,6</sup> An improved five-phase model and code incorporating finite small disturbance speed, radiation and radiation coupling with

dynamics assisted several projects,<sup>7,8</sup> and was web published<sup>9</sup> in 2000 and in 2008<sup>10</sup>. Plasma self-absorption was included in 2007. It has been used extensively as a complementary facility in several machines, for example, UNU/ICTP PFF the NX2, NX1, and DENA. It has also been used<sup>11</sup> in other machines for design and interpretation. Information obtained from the model includes axial and radial velocities and dynamics, soft x-ray SXR emission characteristics and yield design of machines optimization of machines, and adaptation to other machine types such as the Filippov-type DENA. A study of speed-enhanced neutron yield was also assisted by the model code. A detailed description of the model is already available on the internet.<sup>12</sup>

SXR measurements in INTI PF operated in Neon to identify typical (Normal N) profile<sup>13</sup> and optimizing UNU/ICTP PFF plasma focus for neon soft X-ray operation has been reported based on Lee code.<sup>14</sup> Relevant to our present project is recent work by our group on ion beam which for the first time has established reference units and numbers for fast ion beams (FIB) and fast plasma streams (FPS) from the plasma focus.<sup>15,16</sup>

It has been proven that plasma focus devices are useful for material science Research. In a recent investigation, a 3.3 kJ Mather type plasma focus was used to synthesize FeCo nano-particles. The size of the particles has been increased with increase in the number of focus shots. The saturation magnetization was found to increase in samples prepared with a number of focus shots using repetitive plasma focus NX2.<sup>17</sup>

It has been demonstrated that ions produced with DPF device can be used in the preparation of nanoparticles or nanostructures of a variety of materials without heating or biasing of the substrate and without annealing the nanoparticles with laser, ion beam or thermally. DPF device does not have the major disadvantages of other methods like particulate matter in the film, ultra high vacuum, substrate biasing, substrate heating and annealing etc.<sup>18</sup>

Furthermore, fusion reactors will utilize the reaction  $D + T \rightarrow n (14.1 \text{ MeV}) + He^4 (3.5 \text{ MeV})$  to generate heat for electric power production. Intense Bremsstrahlung radiation as well as charged particles and neutrons will emanate from the burning plasma. Charged particles include fuel ions, alpha particles, and possible heavy ions previously ejected from the walls of the plasma chamber. First wall materials, which will operate at 900–1500 K, must retain their structural integrity in this severe thermal and radiation environment.<sup>19</sup>

It has been shown that the main factors for damage of tungsten as a best fusion first wall material candidate, under high-energy pulses in DPF devices are heat loads which melt the irradiated surface layers, erosion of materials (mass loss by evaporation and thinning of samples), formation of different types of surface defects and microcracks. Wavelike relief of irradiated surface has advantage for more effective extraction of gases produced inside the material in thermonuclear fusion reactor under plasma irradiation.

Damage of composite materials of the type of CFC due to erosion is enhanced if carbon fibers are displaced normally to irradiated surface. Experiment have confirmed the advantage of DPF devices for preliminary estimation and test of material behavior in extreme conditions in fusion reactor with inertial plasma confinement.<sup>20</sup>

In this paper, Dual Plasma Focus (DuPF) numerical experiments using the Lee Model code and preliminary 3D design drawings using SolidWorks software are presented.

## 2. Numerical Experiments

In existing plasma focus facilities it is the established practice to maximize the yield in the production of any desired radiation. This in almost all cases means adjusting the plasma focus for intense compression is a selected gas; for example for fusion neutrons, deuterium is selected; for SXR lithography, neon is selected, for micro-machining, argon or a deuterium-argon or argon-krypton mixture. On the other hand for good deposition conditions it may be necessary to reduce focus intensity; using the focusing not so much for its explosive emission of intense radiation but for its storage of plasma energy and a subsequent release of the stored energy into streaming plasma. The Lee Model code is used as a modeling tool for the computation of plasma ion beams and high-speed plasma streams from the plasma focus. One of the results shows that a low-voltage, high-energy plasma focus has big advantages as a source of fast ion beams and high-speed plasma streams. In addition its dynamics could also be slowed down and its high energy can be used to produce a long more uniform pulse for materials fabrication.

We explore the use of a single plasma focus device with two interchangeable anodes to produce:

- Intense ion beam and streaming plasma pulses for studies of potential fusion reactor wall materials based on FFM.
- High-power, long-duration and uniform large-area flow for synthesis of nano-materials based on SFM.

The key to the production of these two distinct regimes of operation of the plasma focus, the intense pinch regime and the plasma flow regime, is the speed parameter which may be expressed as  $(I_{\text{peak}}/a)/\sqrt{\text{torr}}$  where 'a' is the radius and 'torr' is the pressure. For plasma focus operated in intense neutron-optimised regime in deuterium the speed factor is known to be in the region of  $(90 \text{ kA/cm})/\text{Torr}^{0.5}$ .<sup>8</sup> At typical operation of 4 Torr deuterium the required current density may be taken to be  $180 \text{ kA/cm}$  'a'. On the other hand we expect that at a speed factor  $< (50 \text{ kA/cm})/\text{Torr}^{0.5}$  a PF will typically be not operating at optimized intense pinch. The radiation and ion beam emission from the low speed parameter pinch will be reduced. The design of a plasma focus that operate interchangeably in both regimes will hinge on designing it to operate efficiently in two different speed factors one of which is large of the order of  $(90 \text{ kA/cm})/\text{Torr}^{0.5}$  and the other less than half that value.

Tables 1 & 2 present tube, model and operational parameters of DuPF for FFM and SFM.

Table 1. Tube, Model and Operational parameters of DuPF in FFM

Tube Parameter	Lo=50 nH	Co=2700 μF	b=8 cm	a=5 cm	Z <sub>0</sub> =70 cm	r <sub>0</sub> =1 mΩ
Model Parameters	Massf=0.1	Currf=0.7	Massfr=0.2	Currfr=0.7		
Operational Parameters	V <sub>0</sub> =9 kV	P <sub>0</sub> =6 Torr (Deuterium)				

Table 2. Tube, Model and Operational parameters of DuPF in SFM

Tube Parameter	$L_0=50$ nH	$C_0=2700$ $\mu$ F	$b=15$ cm	$a=10$ cm	$Z_0=70$ cm	$r_0=1$ m $\Omega$
Model Parameters	Massf=0.1	Currf=0.7	Massfr=0.2	Currfr=0.7		
Operational Parameters	$V_0=5$ kV	$P_0=10$ Torr (Deuterium)				

Results are shown in comparative graphs, each figure compares FFM with SFM. Computed discharge current of DuPF versus time are shown in figure 1, and computed radial trajectories in Fig. 2. Figure 3 shows that DuPF acts as a pulsed neutron source in FFM. In particular, Fig. 2 shows the much slower radial speed of the SFM and its much bigger pinch exit area.

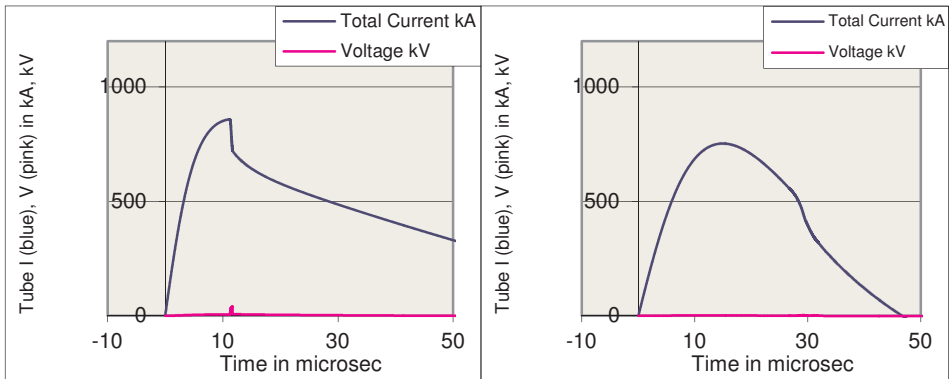

Fig 1. Computed discharge current for DuPF from Lee Code, FFM, 6 Torr D (Left). SFM, 10 Torr D (Right).

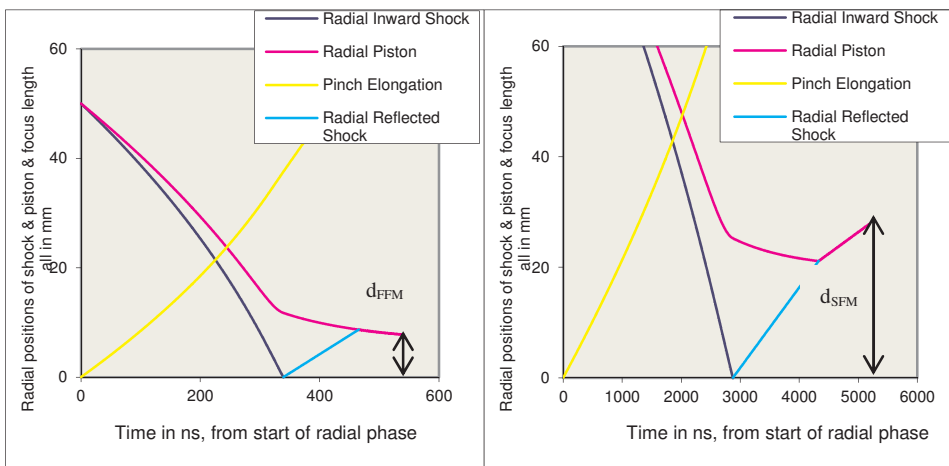

Fig 2. Computed radial trajectories for DuPF from Lee Code, FFM, 6 Torr D (Left). SFM, 10 Torr D (Right).

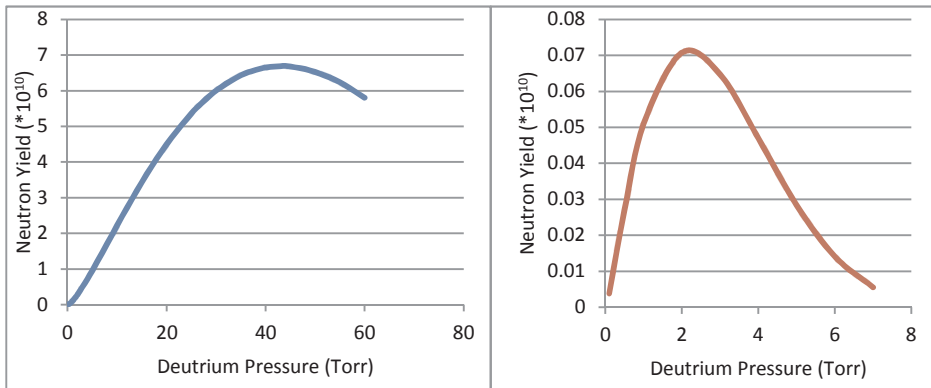

Fig 3. Computed neutron yield versus Deuterium pressure from Lee Code for DuPF, FFM (Left), SFM (Right).

### 3. Results and Discussion

Computed FFM and SFM results based on Lee code are in table 3. Pinch current of FFM is 2.15 times more than SFM and plasma speed in FFM is higher than SFM.  $I/a$  parameter are 172 kA/cm and 75 kA/cm for FFM and SFM consequently. Speed factor of FFM is 2.91 times more than SFM. All of these differences lead to deeper and sharper pinch signal for FFM in comparison with SFM as shown in figure 1. It means magnetic pressure compressing the pinch column in FFM is higher than SFM.

Plasma streams exit radius at the end of focus for FFM and SFM are estimated from figure 2. Cross sectional area of plasma stream at pinch exit for SFM is 12 times more than for FFM:

$$\frac{\text{Plasma Streams Footprint at the end of Focus for SFM}}{\text{Plasma Streams Footprint at the end of Focus for FFM}} = \left( \frac{d_{\text{SFM}}}{d_{\text{FFM}}} \right)^2 = (27/7.87)^2 = 11.77$$

FIB ion energy, beam energy, energy flux for FFM is higher than SFM. Also damage factor of FFM is 93 times more than SFM.

Based on these results, DuPF in FFM state is useful for fusion relevant material testing in comparison with SFM state, because:

- Plasma Streams energy of FFM is higher than SFM
- Current density of FFM is higher than SFM
- FIB damage factor of FFM is higher than FFM

DuPF in SFM state is useful for materials deposition and nano-materials fabrication, because:

- Plasma streams energy of SFM is lower than FFM
- Plasma streams area of SFM is higher than FFM
- SFM percentage energy yield (into plasma) is higher than FFM

Table 3. Comparative table of FFM and SFM of DuPF.

Parameter	FFM	SFM
b (cm)	8	15
a (cm)	5	10
c	1.6	1.5
z <sub>0</sub> (cm)	70	70
P (Torr)	6	10
V <sub>0</sub> (kV)	9	5
I <sub>peak</sub> (kA)	858	753
I <sub>pinch</sub> (kA)	523	243
v <sub>a</sub> (cm/μs)	9.4	3.2
v <sub>s</sub> (cm/μs)	21.3	4.5
v <sub>p</sub> (cm/μs)	15.3	3.4
(c <sup>2</sup> -1)/Inc	3.32	3.08
Bank surge imp (mΩ)	4.3	4.3
Rdyn axial (mΩ)	4.4	1.3
I/a (kA/cm)	172	75
SF (kA/cm/Torr <sup>0.5</sup> )	70	24
FIB ion energy (keV)	104	7
FIB beam energy (kJ)	2.10	0.99
FIB energy flux (W m <sup>-2</sup> )	1.5E+14	4.7E+11
FIB damage ftr (Wm <sup>-2</sup> s <sup>0.5</sup> )	4.1E+10	4.4E+08
PS energy (J)	9965	6451
PS speed exit (cm/μs)	25	2
Plasma Footprint radius (mm)	7.85	27.1
J <sub>b</sub> flux ions (m <sup>2</sup> s <sup>-1</sup> )	8.9E+27	4.1E+26
Fluence ions (m <sup>-2</sup> )	6.7E+20	3.5E+20
EINP	13 %	25%
EINP1 wrk on pnch (J)	14170	8437
Ion Current (kA)	270.8	159.9
Current Density (A m <sup>-2</sup> )	1.4E+09	6.6E+07
Numb ions per shot	1.3E+17	8.6E+17

We have carried out numerical experiments in argon. The results show that it may be advantageous to operate our dual plasma focus in argon for both FFM and SFM. This will be investigated further.

#### 4. PF-160 Dual Plasma Focus (DuPF) industrial 3D design drawings

PF-160 Dual Plasma Focus (DuPF) industrial 3D design drawings using SolidWorks software are presented in figures 4-6. Two interchangeable electrodes enable it to be

optimized for both Slow Pinch Mode (SFM) and Fast Pinch Mode (FFM). Starting with available  $6 \times 450 \mu\text{F}$  capacitors rated at 11kV (10% reversal), numerical experiments indicate safe operation at 9 kV, more than 6 Torr deuterium with FFM anode of 5 cm radius; producing intense ion beam and streaming plasma pulses which would be useful for studies of potential fusion reactor wall materials. On the other hand operating at 5 kV, near 10 Torr deuterium with SFM anode of 10 cm radius leads to long duration uniform flow which could be more suitable for synthesis of nano-materials.

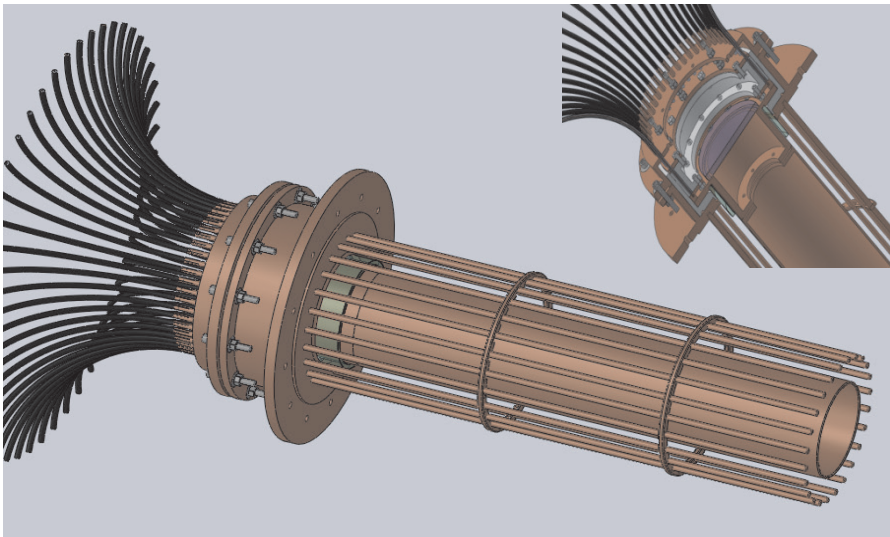

Figure 4. SFM electrodes and main collector Assembly of DuPF with 197 kg weight.

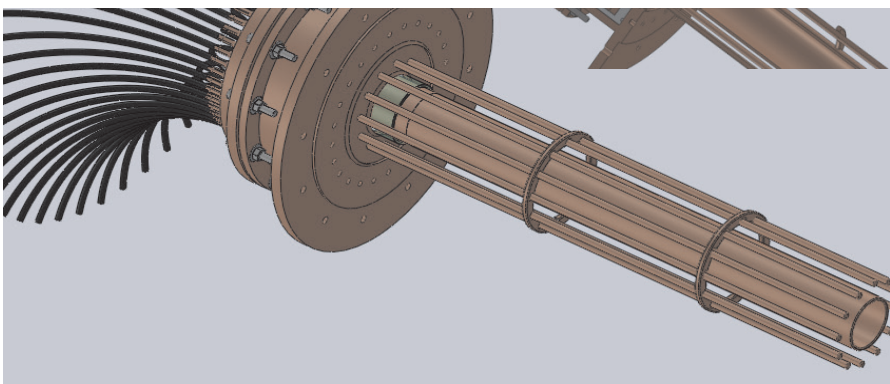

Figure 5. FFM electrodes and main collector Assembly of DuPF with 170 kg weight.



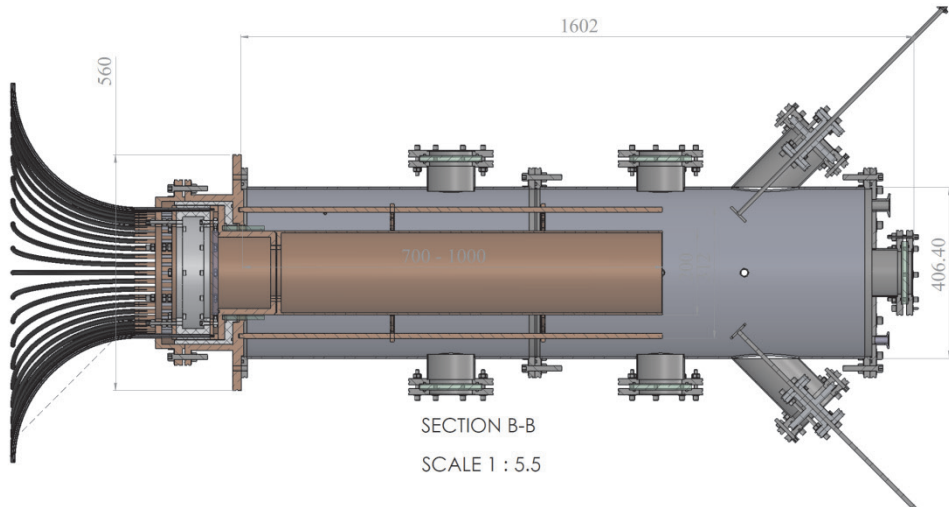

Figure 6. Electrodes and vacuum chamber of DuPF, SFM (All dimensions are in mm).

## 5. Conclusion

PF-160 Dual Plasma Focus (DuPF) numerical experiments using the Lee Model Code and industrial 3D design drawings using SolidWorks software are presented. This DuPF uses two interchangeable electrodes enabling it to be optimized for both Slow Pinch Mode (SFM) and Fast Pinch Mode (FFM); the latter using a speed factor (SF) of more than  $70 \text{ kA cm}^{-1} \text{ Torr}^{-0.5}$  for FFM in deuterium and the former with SF of less than half that value for SFM.

Starting with available  $6 \times 450 \mu\text{F}$  capacitors rated at 11kV, numerical experiments indicate safe operation at 9 kV, about 6 Torr deuterium with FFM anode of 5 cm radius; producing intense ion beam and streaming plasma pulses which would be useful for studies of potential fusion reactor wall materials.

On the other hand operating at 5 kV, near 10 Torr deuterium with SFM anode of 10 cm radius leads to long- duration, large-area uniform flow which could be more suitable for synthesis of nano-materials. Also numerical experiments show that DuPF can be applied as a pulsed neutron source in FFM state even in more than 20 Torr deuterium gas.

## Acknowledgment

We acknowledge research grants INT-CPR-01-02-2012 and FRGS/2/2013/SG02/INTI/01/1.

## References

1. A. C. Pătrău, "Electron and Medium Energy X-ray Emission from a Dense Plasma Focus," PhD Thesis National Institute of Education, Nanyang Technological University, Singapore, (2002).

2. V A Gribkov et al, "Plasma dynamics in PF-1000 device under full-scale energy storage: I. Pinch dynamics, shock-wave diffraction, and inertial electrode," *J. Phys. D: Appl. Phys.* **40**, 1977 (2007).
3. IAEA-TECDOC-1708, "Integrated Approach to Dense Magnetized Plasmas Applications in Nuclear Fusion Technology," International Atomic Energy Agency (IAEA), Vienna, (2013).
4. B.J. Chan, Four-chord Interferometer Measurements of the ZaP Flow Z-Pinch, Washington: University of Washington, (2008).
5. S. Lee, "Technology of the Plasma Focus," Laser and Plasma Technology, World Scientific, Singapore, ISBN 9971-978-27-X pp. 387-420, (1985).
6. S. Lee et al, "A simple facility for the teaching of plasma dynamics and plasma nuclear fusion," *Amer J Phys* **56**, 62 (1988).
7. S.Lee et al, "High rep rate high performance plasma focus as a powerful radiation source," *IEEE Trans. Plasma Sci.* **26**, 1119 (1998).
8. S. Lee & A Serban, "Dimensions and lifetime of the plasma focus pinch," *IEEE Transactions on Plasma Science* **24**, 1101 (1996).
9. S. Lee, <http://ckplee.myplace.nie.edu.sg/plasmaphysics/> 2000, (2007).
10. S. Lee, Radiative dense plasma focus computation package: RADPF, <http://www.plasmafocus.net>; <http://www.intimal.edu.my/school/fas/UFLF/> (archival websites), (2013).
11. S. Lee, "Twelve Years of UNU/ICTP PFF-A Review," ICTP Preprint IC/98/231, Kuala Lumpur, (1998).
12. S. Lee & S H Saw, "Pinch current limitation effect in plasma focus," *Applied Physics Letters* **92**, 021503 (2008).
13. S. H. Saw et al, "SXR Measurements in INTI PF Operated in Neon to Identify Typical (Normal N) Profile for Shots With Good Yield," *IEEE Trans. Plasma. Sci.* 10.1109/TPS.2013.2281333 (2013).
14. S. H. Saw, "Optimizing UNU/ICTP PFF Plasma Focus for Neon Soft X-ray Operation," *IEEE Transactions on Plasma Science* **37**, 1276 (2009).
15. S. Lee & S H Saw, "Plasma Focus Ion Beam Fluence and Flux –Scaling with Stored Energy," *Phys. Plasmas* **19**, 112703 (2012).
16. S. Lee & S H Saw, "Plasma Focus Ion Beam Fluence and Flux –for various gases," *Phys. Plasmas* **20**, 062702 (2013).
17. T. Zhang et al, "Characteristics of FeCo nano-particles," *J. Phys. D: Appl. Phys.* **39**, 2212 (2006).
18. M. P. Srivastava, "Plasma Route to Nanosciences and Nanotechnology Frontiers," *J. Plasma Fusion* **8**, 512 (2009).
19. F. W. Clinard, "First wall materials problems in fusion reactors," *J. Vac. Sci. Technol.* **12**, 510 (1975).
20. E. Demina, "Application of a Plasma Accelerator of the Dense Plasma Focus Type in Simulation of Radiation Damage and Testing of Materials for Nuclear Systems," in International Topical Meeting on Nuclear Research Applications and Utilization of Accelerators, IAEA, Vienna, (2009).