

## DEVELOPMENT AND PERFORMANCE EVALUATION OF A LOW COST ELECTROCARDIOGRAM

Wara Samuel T.<sup>1</sup>, Orovwode Hope E.<sup>2</sup>, Jinadu A.<sup>3</sup>, Agbetuyi Felix A.<sup>4</sup> & Adoghe Anthony U.<sup>5</sup>

<sup>1,2,4,5</sup>Electrical and Information Engineering Department, School of Applied Engineering, College Engineering, Covenant University, Ota, Nigeria. E-mails-hope.orovwode@covenantuniversity.edu.ng

<sup>3</sup>Department of Electrical/ Electronics Engineering, College of Engineering, Federal University of Agriculture, Abeokuta, Ogun State, Nigeria

### ABSTRACT

Heart related issues have been so common according to medical research; the young and aged people are mostly affected. Electronic diagnosis has made a great impact in solving Heart related issues. However, the cost for acquiring stethoscope and Electrocardiographs is often expensive. This simple, low cost microcontroller based heartbeat rate measuring device was developed using a reverse engineering technique. A five volts power supply (5V) was developed and used to power a sensor arrangement. The sensor comprised of an Infrared emitting diode and a photodiode. An amplifier unit was added to boost the signal coming from the sensor after which the signal was sent to a microcontroller. The microcontroller was programmed to count detected pulse for fifteen seconds and give the display through a connected 3-Digit seven segments. The device was packaged in a specially designed plastic casing; adequate spacing was provided for the digital readout, optical sensor, power switch and the control switches. Testing was done by using the device to measure the heartbeat rate of 42 individuals and the result compared with that of a standard device. The result using the developed device was found to be satisfactory as 73.69bpm average measurement while the polar sonic standard device gave an average reading 74.23bpm. A positive strong correlation of 0.907 was obtained for the two devices showing that the developed device is a good substitute for the (polar sonic) standard device. The device is simple in construction, easy to use, portable and cost effective.

**Keywords:** *Heartbeat, Electrocardiographs, low cost, Atrioventricular, Electronic diagnosis.*

### 1. INTRODUCTION

Heartbeat monitoring device (HBMD) is an electronic tool that detects physiological parameters and converts to usable heartbeat rate reading [1]. Heartbeat rate is the number of times the heart beats per minute (bpm) and it is produced via depolarization at the sinoatrial and atrioventricular nodes in the heart. The use of HBMD has evolved since its first invention. HBMD is a common tool in the clinical domain because it appears sensitive to both physiological and psychological disorders [2]. HBMD has been applied as a tool in diagnosis, prognosis and management of patients with health challenges [3], [4]. It is also used by individuals, such as athletes, who are interested in monitoring their heartbeat rate to gain maximum efficiency from their training. The  $R_{\text{wave}}$  to  $R_{\text{wave}}$  interval (R-R interval) is the inverse of the heart rate. Other areas of application HBMD are in sports and heartbeat rate variability (HRV) training device [5,6,7]. For example, the shape of the heart beat waveform reflects arterial changes correlated with hypertension. In addition, HRV training offers promise for the treatment of migraine, reduces asthma severity followed by improvement in cases of diabetic ulcer and frostbites.

Heartbeat rate measurement is done by first finding pulses due to blood pressure flowing in the body. This pulse rate can be taken at any point on the body where the artery's pulsation is transmitted to the surface by pressuring it with the index and middle fingers; often it is compressed against an underlying structure like the bone. Use of thumb for measuring another person's heartbeat rate may not be ideal as its strong pulse may interfere with correct perception of the target pulse.

#### 1.1 Statement of the Problem

Some methods exist for measuring heartbeat rate however, the highlighted problems are associated with them and these include:

- Stethoscopes have greater ability to spread germs and viruses, since they are normally used on bare skin and sometimes on extremely ill patients.[8]
- Inattentiveness of nurses during manual measurement may lead to inaccuracy of measured value.

- Counting heartbeat by manual method for a full minute might be too long a time especially in an emergency situation.
- .Since the stethoscope magnifies sounds, any accidental noise that is too loud can potentially damage the listener's ears.[8]
- Research through the use of questionnaire shows that the market price of a heartbeat monitoring device is forty thousand naira (₦40,000) in available electronics market.

**2. MATERIALS AND METHOD**

This work is aimed at designing a device that shall have the capacity and capability of taking an input signal from the finger tip of the individual whose heartbeat is to be read.

The device has two main stages- the hardware and the software. The hardware is sub-divided into power supply, input, processing (filter and amplifier circuit), and output stages (digital readout).

Figure 1 shows the block diagram of the device and the relationship between the blocks.

**2.1 The Power Supply Stage**

The developed device was to be operated with DC voltage source and independent of electricity supply since its application may be required in places where electricity is not available. The power supply stage consists of a 9V battery regulated as shown in Figure 2 to 5V using fixed regulator and associated components.

**2.2 The Sensor Design**

The sensor unit is made up of an infrared diode as emitter and the photo diode as a detector arranged as shown Figure 3 to detect the pulsating motion of blood in the finger veins.

A small signal transistor was used to amplify the low level signals and as a switch. Typical  $h_{fe}$  values for the transistor ranges from 10 to 500, with maximum collector current ( $I_c$ ) ratings from about 80 to 600 mA is adequate. [6]

An automatic switch is required to turn OFF the infrared diode after the targeted 15 seconds count duration. The transistor (BC547) used to switch ON the infrared LED when collector voltage ( $V_c$ ) is less than the emitter voltage ( $V_E$ ) [9]

The DC current gain,  $\beta = 200$  [10]

To limit the biasing current at the base, a resistor whose value is determined using equations (4) knowing that the collector current with respect to ground is  $I_c = 0.12A = 120mA$  (current flowing through the diode  $D_2$ )

$$I_B R_E = V_E + V_{BE} \tag{1}$$

$$V_{BE} = V_B - V_E = +0.6V \tag{2}$$

$$I_C = \beta I_B \tag{3}$$

$$R_B = \frac{V_B}{I_B} \tag{4}$$

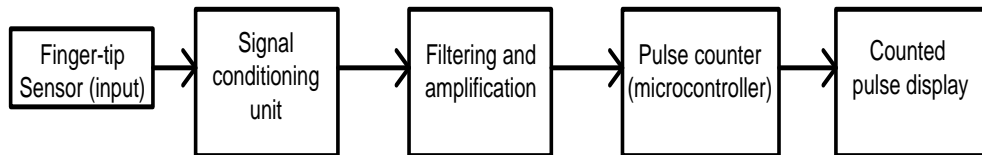

Figure 1: Block diagram of the developed device

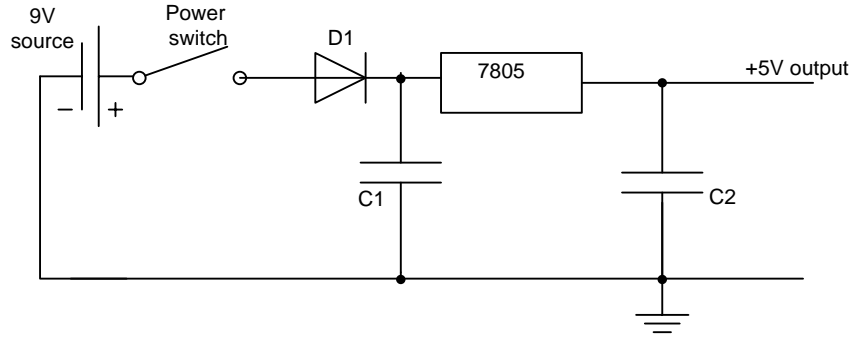

Figure 2: Power Supply Circuit

To protect photo detector diode from excessive current, a resistor was placed in series with it. The value of the series resistor  $R_S$  depends on the forward voltage  $V_F$  of the LED, the supply voltage  $V_{+}$ , and the desired forward current  $I_F$  as expressed in equation (5)

$$R_s = \frac{V_{CC}-V_F}{I_F} \tag{5}$$

**2.3 The Signal Conditioning Circuit**

The signal conditioning circuit consists of two identical active low pass filters with a cut-off frequency of 2.5 Hz. The operational amplifier LM358 was used because of it’s ability to amplify low signal and also operates on a single power supply but generates rail-to-rail output swing. The filtering of the signal is necessary to block-off any higher frequency noise present in the signal. A non-inverting negative feedback amplifier was used because it keeps the output waveform in phase with the input waveform The gain of each filter stage was calculated from equation (10) by selecting suitable values for  $R_4$  and  $R_5$ . The overall gain is the product of the gains of the two amplifiers’ gain. The cut-off frequency (in hertz) is defined in equation (6) as [9]:

$$f_c = \frac{1}{2\pi RC} \tag{6}$$

For reliable result, biasing resistor for the op-amp should have resistance value between 10kΩ and 100kΩ. [9]. For a cut-off frequency of 2.5Hz, the capacitor value was found as

$$c = \frac{1}{2\pi f_c R_6} \tag{7}$$

When an input voltage  $V_{in}$  is applied to the non-inverting input the gain of the amplifier is given in [12] as:

$$V_{in} = \frac{R_1}{R_1 + R_2} \times V_{OUT} \tag{8}$$

$$\text{Voltage gain, } A_{v1} = \frac{V_{out}}{V_{in}} \tag{9}$$

$$\text{Then } A_{v1} = \frac{V_{out}}{v_{in}} = \frac{R_1+R_2}{R_1} \tag{10}$$

For the second amplifying stage,  $A_{v2}$ , the calculating steps are repeated. The total gain would be

$$A_{v_{total}} = A_{v1} * A_{v2} \tag{11}$$

At the output of the second stage of the amplifier circuit, an LED “D<sub>3</sub>” was connected in series with ( $R_{10}$ ) a resistor to limit the current flowing through it. The LED blinks every time a heart beat was detected. The circuit diagram is as shown in Figure 4.

**2.4 The Output Stage**

The output stage consists of the microcontroller receiving the input signal which has been processed by the signal conditioning unit through the Pin 3 (T0CKI). The microcontroller was programmed using C language such that once the start button is pressed the microcontroller activates the infrared transmitter in the sensor unit for 15 sec. During this interval, the number of heartbeats arriving at the Pin 3 (T0CKI) input is counted. The actual heart rate is 4 times the counted value, and the resolution of measurement is 4. The microcontroller runs at 4.0 MHz using an external crystal. The complete circuit diagram is as shown in Figure 5.

### 3. RESULT AND DISCUSSION

Adults within 20-25years age bracket heartbeat rate were sampled using a standard device and the developed device. For adults, heartbeat rate ranges from 60 to 100 [5]. The result is as shown in Table 1. The statistical analysis of the result was as follows:

Let the mean for standard device =  $\mu_x$

$$\mu_x = \frac{\sum_1^n X}{n} \quad (12)$$

let mean for the developed device =  $\mu_y$

$$\mu_y = \frac{\sum_1^n Y}{n} \quad (13)$$

where

X = individual heartbeat rate for the standard device (polar sonic)

Y = individual heartbeat rate for the developed device

n = number of sampled individual

Standard deviation for standard device (polar sonic), s.d<sub>x</sub>

$$s. d_x = \sqrt{\frac{\sum_1^n (X - \mu_x)^2}{n-1}}$$

Standard deviation for the developed device, s.d<sub>y</sub>

$$s. d_y = \sqrt{\frac{\sum_1^n (Y - \mu_y)^2}{n-1}}$$

$$\text{Correlation, } \tau = \frac{n \sum XY - (\sum X)(\sum Y)}{\sqrt{[n \sum X^2 - (\sum X)^2][n \sum Y^2 - (\sum Y)^2]}}$$

Substituting values from Table 1, gives

$$\mu_x = 74.23 \text{ bpm}$$

$$s. d_x = 8.0$$

Therefore, the measured heartbeat rate using a standard heartbeat monitor (polar sonic) ranges from:

$$\mu_x \pm s. d = 74.23 \pm 8.0$$

$$= 66.23 \text{ to } 82.23$$

$$\approx 66 \text{ bpm to } 82 \text{ bpm}$$

This value falls within 60 to 100 bpm (normal heart beat rate for adult)

$$\mu_y = 73.69 \text{ bpm}$$

Standard deviation for the developed device:

$$s. d_y = 7.7$$

Therefore, the measured heartbeat rate using the developed heartbeat monitor ranged from:

$$\mu_y \pm s. d = 73.69 \pm 7.7$$

$$= 77.69 \text{ to } 81.39$$

$$\approx 74 \text{ bpm to } 81 \text{ bpm}$$

This value falls within 60 to 100 bpm (normal heart beat rate for adult)

$$\text{Correlation} = \tau = \frac{n \sum XY - (\sum X)(\sum Y)}{\sqrt{[n \sum X^2 - (\sum X)^2][n \sum Y^2 - (\sum Y)^2]}}$$

$$= \frac{[42 \times 232121] - [3118 \times 3095]}{\sqrt{[(42 \times 234222) - (3118)^2][42 \times 230519 - (3095)^2]}}$$

$$\tau = \frac{98872}{\sqrt{115400 \times 102773}} = \frac{98872}{108903.6}$$

$\tau = 0.907$  {the correlation is strong positive} as shown in Figure 6.

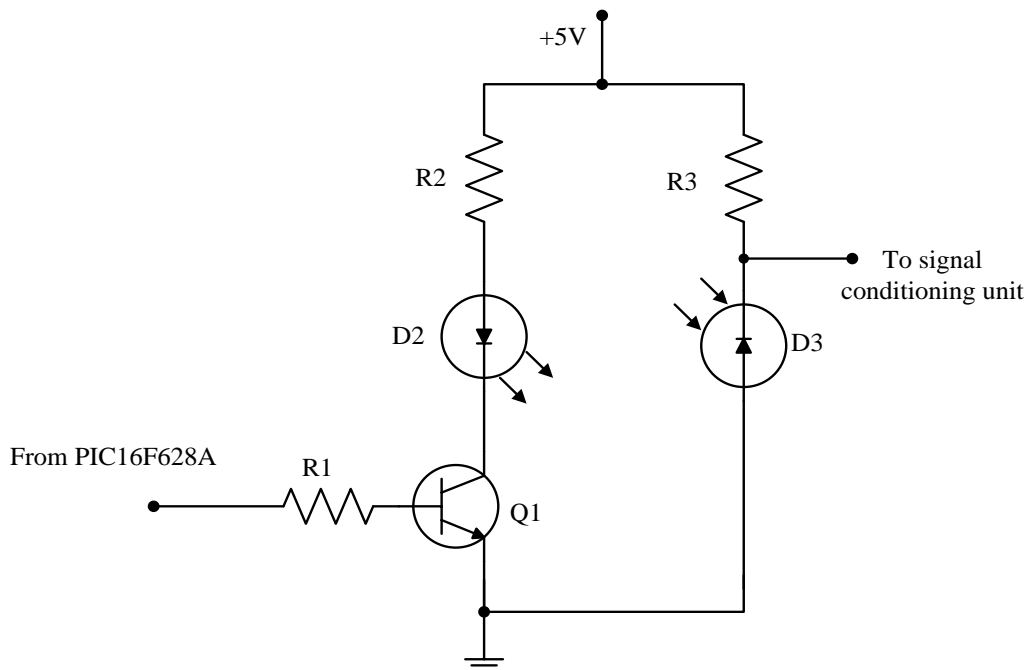

Figure 3: The Sensor Circuit

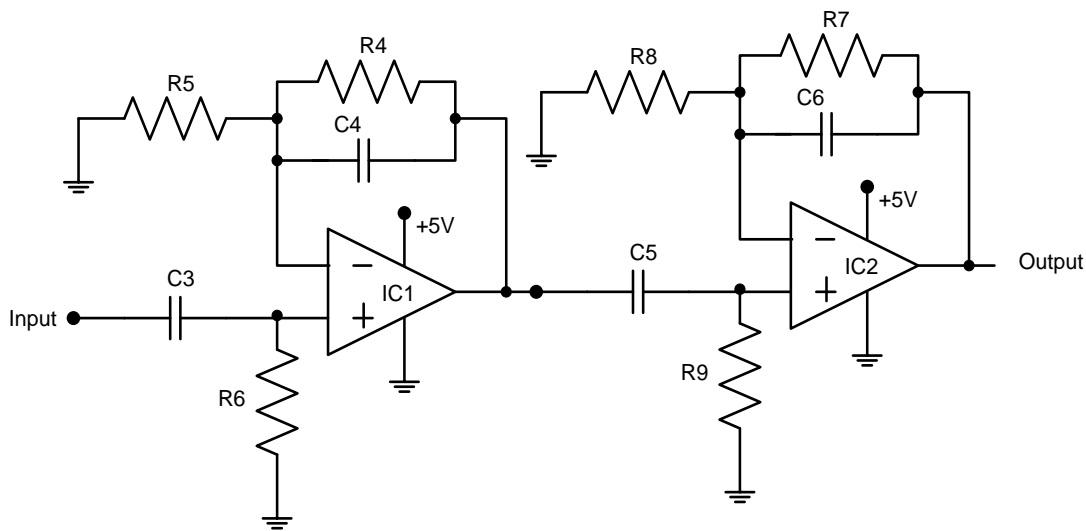

Figure 4: The Amplifier and filtering Circuit

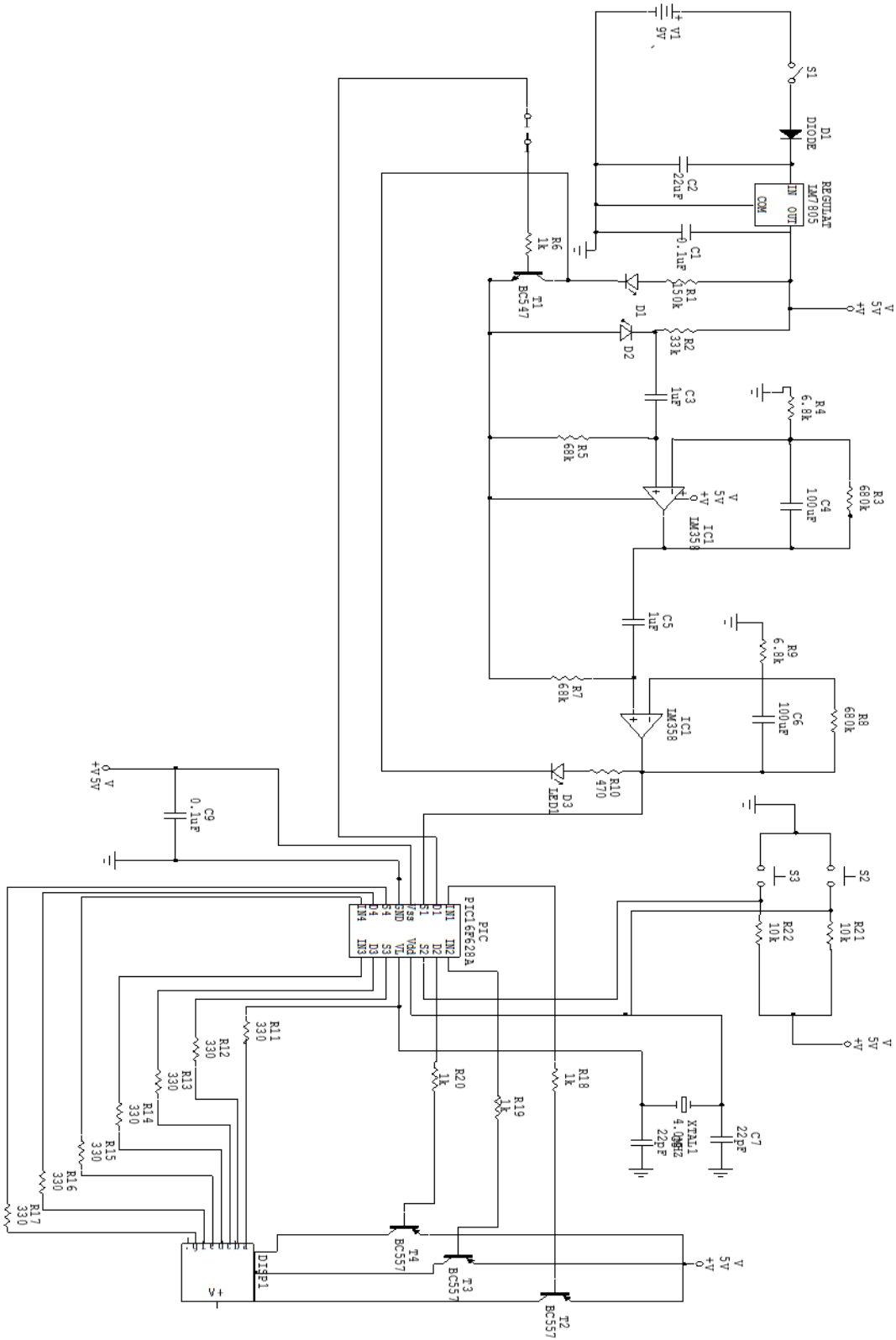

Figure 2.6: The Complete Circuit Diagram

Table 1 : Statistical Analyses Data

INDIVIDUAL NUMBER	X(bpm)	Y(bpm)	X <sup>2</sup>	Y <sup>2</sup>	XY	(X - $\mu_x$ ) <sup>2</sup>	(Y - $\mu_y$ ) <sup>2</sup>
1	70	72	4900	5184	5040	18.32	2.85
2	72	72	5184	5184	5184	5.20	2.85
3	72	70	5184	4900	5040	5.20	13.61
4	78	71	6084	5041	5538	13.83	7.23
5	77	77	5929	5929	5929	7.39	10.90
6	77	81	5929	6561	6237	7.39	53.43
7	82	84	6724	7056	6888	59.59	106.29
8	84	79	7056	6241	6636	94.49	28.19
9	80	72	6400	5184	5760	32.72	2.85
10	74	72	5476	5184	5328	0.0784	2.85
11	72	78	5184	6084	5616	5.20	18.57
12	75	80	5625	6400	6000	0.52	39.81
13	79	82	6241	6724	6478	22.27	69.05
14	80	81	6400	6561	6480	32.72	53.43
15	80	81	6400	6561	6480	32.72	53.43
16	60	61	3600	3721	3660	203.9	161.03
17	68	69	4624	4761	4692	39.44	21.99
18	77	72	5929	5184	5544	7.39	2.85
19	84	84	7056	7056	7056	94.49	106.29
20	82	82	6724	6724	6724	59.59	69.05
21	77	77	5929	5929	5929	7.39	10.90
22	76	70	5776	4900	5320	2.96	13.61
23	70	76	4900	5776	5320	18.32	5.33
24	61	66	3721	4356	4026	176.35	59.13
25	64	65	4096	4225	4160	105.67	75.50
26	70	70	4900	4900	4900	18.32	13.61
27	72	70	5184	4900	5040	5.20	13.61
28	63	61	3969	3721	3843	127.23	161.03
29	64	64	4096	4096	4096	105.67	93.89
30	84	85	7056	7225	7140	94.49	127.91
31	86	82	7396	6724	7052	11.72	69.05
32	72	69	5184	4761	4968	5.20	21.99
33	77	75	5929	5625	5775	7.39	1.71
34	70	70	4900	4900	4900	18.32	13.61
35	72	75	5184	5625	5400	5.20	1.71
36	76	72	5776	5184	5472	2.96	2.85
37	84	80	7056	6400	6720	94.49	39.81
38	84	84	7056	7056	7056	94.49	106.29
39	89	82	7921	6724	7298	216.67	69.05
40	74	72	5476	5184	5328	0.0784	2.85
41	58	58	3364	3364	3364	265.03	246.17
42	52	52	2704	2704	2704	496.39	470.45
	$\sum X =$ 3118	$\sum Y =$ 3095	$\sum X^2 =$ 34222	$\sum Y^2 =$ 230519	$\sum XY =$ 232121	$\sum (X - \mu_x)^2 =$ =2621.987	$\sum (Y - \mu_y)^2 =$ 2446.61

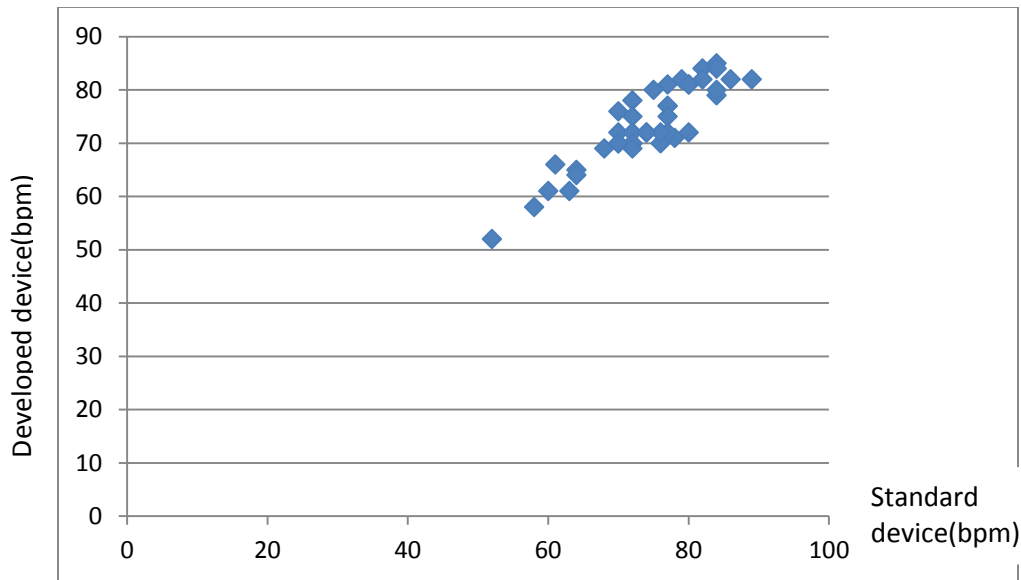

Figure 7: The Correlation Graph.

The correlation graph of the measurements from the two devices (developed and standard) showed that the developed device is a good substitute for the standard device with an added advantage of lower price.

#### 4. CONCLUSION

A low cost heartbeat rate monitoring device based on reverse engineering has been developed. The system detects the variations in blood volume from the index finger and convert it to a pulse. The signal was amplified, filtered and sent to a programmed microcontroller which counts the number of pulses for 15 seconds. Testing was done by using the device to measure the heartbeat rate of 42 individuals and the result compared with that of a standard device. The result, using the developed device, was 73.69bpm average measurement while the polar sonic standard device gave an average reading of 74.23bpm. There is a positive strong correlation of 0.907. This showed that the developed instrument could be used as a substitute for a much more expensive polar sonic standard type for heart beat monitoring.

#### 5. REFERENCES

- [1] Heart Rate Monitors, January 19, 2012 <http://www.walmart.com/cp/Heart-Rate-Monitors/1078145>
- [2] John G. Webster, "Medical Instrumentation-Application and Design", John Wiley and Sons, Singapore (2005).
- [3] A. I. Hernandez, F. Mora, G. Villegas, G. Passariello, G. Carroult, "Real-time ECG transmission via internet for non-clinical applications", *IEEE Trans. on Information Tech. in Biomedicine*, vol. 5, no. 3, pp. 253-257, 2001.
- [4] Arif C., "Embedded Cardiac Rhythm Analysis and Wireless Transmission (Wi-CARE)," *MS Thesis*, School of Computing and Software Engineering, Southern Polytechnic State University, Marietta, Georgia, USA, 2004.
- [5] Ayang-ang C. and Sison L., "Electrocardiograph Pre-Filtering, QRS Detection, and Palm Display Programming for Biomedical Applications," in *Proceedings of the ECE Conference*, University of St. Tomas, Manila, 2001.
- [6] Balm G., "Cross-Correlation Techniques Applied to the Electrocardiogram Interpretation *Microcontroller Based Heart Rate Monitor 157 Problem*," *IEEE Transactions on Biomedical Engineering*, vol. 14, no. 4, pp. 258-262, 1979.
- [7] B.H. Yang, S. Rhee, "Development of the ring sensor for health-care automation", *Robotics and Autonomous Systems*, vol. 30, pp. 273-281, 2000.
- [8] Celler B., "Remote Monitoring of Health Status of the Elderly at Home," *International Journal of Biomedical Computing*, vol. 40, no. 2, pp. 147-153, 1995.
- [9] A V Afenye, O Owen, O M Stephen "principles of Electronic devices and circuits" stemic publication (2005).
- [10] BC546 data sheet Fairchild Semiconductor available at [www.fairchildsemi.com/ds/BC/BC547.pdf](http://www.fairchildsemi.com/ds/BC/BC547.pdf)