

Off-grid Hybrid Renewable Power Generation as a Vehicle for Accelerated Rural Development in Africa

Abdul-Latif G. Raji, John M. VanColler
School of Electrical and Information Engineering,
Private Bag 3, WITS 2050
Johannesburg, South Africa

e-mail: abdullatif.raji@gmail.com, John.vanColler@wits.ac.za

Abstract— Many rural communities in Africa located far away from transmission corridors do not enjoy electricity supply and cannot hope to be connected to their national grids in the foreseeable future. However, many among such communities have small hydro potential and moderate wind resources. In this paper, an off-grid, hybrid, wind-hydro power generation model is proposed for such communities. Candidate sites for this model would possess small hydro capacity of up to 500 kW and annual mean wind speed of 7 – 10 m/s at 10 m hub height. The operation of an existing small, run-of-river hydro station in conjunction with a hypothetical, in-situ wind farm feeding loads typical of rural areas was simulated to demonstrate the feasibility of the scheme. Simulation results for the system operation were found to be satisfactory. It is anticipated that, with the provision of subsidy by government and/or development agencies, implementation of this model will translate into rapid economic and social transformation of numerous rural areas across Africa

Index Terms – Off-grid; hybrid; renewable power generation; rural development; STATCOM; sinusoidal pulse-width modulation; EMTP-ATP

I. INTRODUCTION

Electricity supply is an indispensable requirement for economic growth and development of all nations. Traditionally, electricity has been generated at large thermal and hydroelectric stations and transmitted on extra high voltage grids over very long distances before being distributed to consumers. The consumers are usually residents of big urban settlements and industrial centres.

Many rural communities have not benefitted from grid-based power supply because utilities have found it uneconomical to extend facilities to areas far removed from the transmission corridors. Meanwhile, great impetus has been given globally to power generation from renewable sources such as wind, solar, mini-hydro and biomass, with some countries targeting the attainment of up to 40 % of demand from renewables only [1 - 3]. Remarkably however, almost the entire power output from renewable sources are still being fed into the various national grids. That has led to the development of a number of national grid code requirements for wind turbines [4-7].

Where available, isolated renewable generating stations operate in single-modes only with the exception of a few, e.g. the wind power plant backed up by diesel generators described in [8]. Such single-mode, stand-alone power stations have been unable to meet local energy demands completely. On the other hand, for most of the studies on hybrid wind/hydro generation reported in the literature, pumped-storage hydro schemes are predominant [11-13]. One notable exception is [14] in which the authors describe a theoretical framework in which two hypothetical facilities in Mexico - a wind farm located in the “LaVente” area and a hydro plant located in the “Presidente Benito Juarez” dam - would operate together to produce up to 20 MW of firm power in real time. That scheme was also intended for connection to the regional electricity distribution network. Thus, the needs of rural communities outside grid networks for reliable power supply still remain unmet.

The objective of this study is to look into the operation of off-grid *hybrid* renewable power generation with a view to establishing the means for a more reliable power supply for rural areas in Africa. In particular, the study will focus on the operation of an existing 150 kW, run-of-river hydro power plant (the Waya Dam Project in Nigeria) in conjunction with a hypothetical, in situ 150 kW wind farm in order to develop a model or template for the establishment of similar hybrid schemes at suitable sites around Africa. Data on the Waya Dam Project were obtained from [9] except for electrical data which were obtained from design of an equivalent generator. The electrical (machine) data are as shown below. Section 1 contains the introduction and a statement of the problem. In section 2, the proposed system operation diagram is described and relevant equivalent circuits and the method of self-excitation derived. Also in section 2, gross estimates of energy capture are determined. Network simulation results are presented in section 3 and section 4 contains the conclusions.

- RA -- Armature resistance, pu = 0.0252
- XL --Armature leakage reactance , pu = 0.0675
- XD -- d-axis synchronous reactance, pu = 0.853
- XQ -- q-axis synchronous reactance, pu = 0.512

- $X_{d'}$ -- d-axis transient reactance, pu = 0.3
- $X_{d''}$ -- d-axis sub-transient reactance pu = 0.0677
- $T_{d'}$ - d-axis short-circuit transient time constant, s = 1.5
- $T_{d''}$ -- d-axis short-circuit sub-transient time constant, s = 0.03
- X_0 -- Zero-sequence reactance, pu = 0.15
- Z_n -- Neutral grounding impedance, pu = 0.
- H -- Inertia constant, s = 4

EXCITATION DATA

- VF, Rated Field Voltage, volts = 40
- IF, Rated Field Current, amps = 62
- RF, Field Winding Resistance, ohms = 0.6

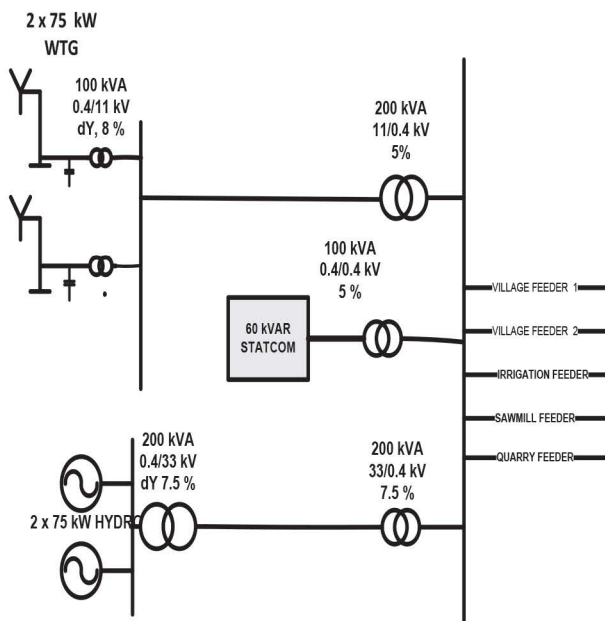

Fig. 1. System Operating Diagram

II. SYSTEM OPERATING DIAGRAM

Fig. 1 shows the system operation diagram (circuit breakers not shown for simplicity). It consists of (a) the two existing 75 kW hydro units which feed into a single 200 kVA, 0.4/33 kV transformer; a 33 kV transmission line, and a 33/0.4 kV distribution transformer, the secondary of which is connected to the main 400 V busbars; and (b) the two 75 kW wind turbine generator units. Each wind turbine unit comprises the wind turbine generator and its step-up 100 kVA, 0.4/11 kV transformer the HV side of which is connected to 11 kV Collector busbars. From the Collector busbars, an 11 kV transmission line conveys the power to a 200 kVA, 11/0.4 kV station transformer, the secondary of which is connected to the main 400 V busbars. At least one hydro unit would be expected to be in service to supply a small base load and be available to provide the required ramping up or down of real power output as dictated by the wind turbine performance, and

also to provide start-up (magnetizing) power (as back-up to self-excitation) at cut-in times of the wind turbine. Also shown in the system diagram are 400 V outgoing feeders for typical rural loads: two 51 kVA village feeders for domestic lighting and power; a 9 kVA feeder for farm and irrigation pumps; a 24 kVA sawmill feeder and a 15 kVA quarry feeder. A 60 kVAR Synchronous Static Compensator (STATCOM) – which is a sinusoidal pulse-width modulated voltage source inverter – is connected to the main busbars via a 100 kVA, 0.4/0.4 kV, 5 % power transformer for continuous wind turbines' terminal voltage regulation (by supplying reactive power to the induction generators when required) and to provide protection during system faults (low voltage ride-through). In addition, by increasing the short circuit MVA, it enhances overall system stability [21 - 25]. The power transformer is also expected to act as a low pass filter for the output of the STATCOM, in addition to its normal role as the inductance between the STATCOM and the main busbars. The Universal Machine Model was used to represent the wind turbine generator and all simulations of the power system were based on EMTP-ATP [18].

The hydro plant and water resources

The essential data of the Waya Dam relevant to this study are [9] :

- Storage Capacity : 30 million cubic meters
- Dead Storage : 8 million cubic meters
- Live Storage : 22 million cubic meters
- Ave Potential Head : 12 meters
- Design Discharge : $2.4 \text{ m}^3 / \text{s}$
- Potential Power : 200 kW

The wind plant and wind resources

The wind resource at the WAYA dam site (Bauchi) is very poor. The annual mean wind speed is less than 3 m/s.. Such is generally the case throughout Nigeria except for very few sites [10] . However, in Africa, locations exist with bountiful wind resources , e. g. the Klein Karoo, near Worcester in the Western Cape; the Great Karoo, near the town of Graaf Reinet in the Eastern Cape [15] ; and the Wind Atlas of South Africa (WASA) sites in South Africa (see www.wasa.csir.co.za) [16]. Candidate sites for the hybrid power plants proposed in this study should have wind resources, at least intermediate between the above two for satisfactory results. A mean wind speed of 7 m/s at 10 m hub height is assumed for the candidate site. The horizontal-axis wind turbine (HAWT) – 30 m in diameter – is employed. It consists of three blades attached to the hub at one end of a horizontal shaft atop a 40 m mast. The configuration of the blades is upwind. At the other end of the shaft, a 75 kW, 400 V, 3-phase, 50 Hz, 4-pole, 1475 RPM squirrel-cage induction motor is installed via a 1:60 gearbox.

No-load, locked-rotor, and stator DC resistance tests of the 3-phase motor were conducted. The no-load characteristics are plotted in Fig. 2. The locked-rotor and stator DC resistance

test results are shown in Tables 1 and 2 respectively. Self-excitation capacitance was estimated from the plot of no-load terminal voltage versus magnetizing susceptance, similar to the methods used in [17, 18, 20]. A capacitance of $C = 500 \mu\text{F}$ was found to be satisfactory.

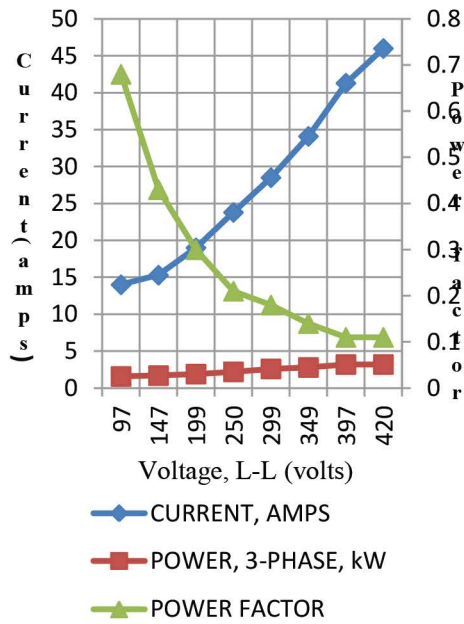

Fig. 2. No-load Characteristics of 75 kW Induction Motor

TABLE I: LOCKED - ROTOR TEST

VOLTAGE, L - L, VOLTS	CURRENT, AMPS	POWER, 3 - PHASE, kW	POWER FACTOR
60	109	3.3	0.3

TABLE 2 - DC RESISTANCE TEST (STATOR WINDING)

WINDING	RESISTANCE (mΩ)
A1 - A2	69.9
B1 - B2	70.1
C1 - C2	69.8
AVERAGE	69.93

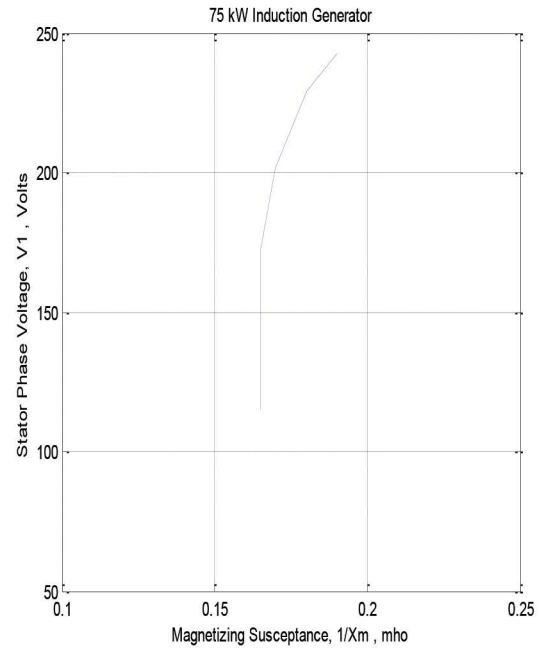

Fig. 2A. Phase Voltage versus Magnetizing Susceptance

Gross estimates of energy capture (a) Energy from the hydro plant

The total annual energy obtainable from the hydro plant was estimated by [9] as 1.08 GWh. This figure assumed 300 days of operation in a year.

(b) Energy from the wind -- The wind resource at a candidate site may be modeled by the Weibull probability density function [18 , 26];

$$g(u) = \frac{\alpha u^{\alpha-1}}{\beta^\alpha} \exp\left(-\left(\frac{u}{\beta}\right)^\alpha\right), \quad u > 0$$

where u = the wind speed. The mean wind speed is given by:

$$\mu = \beta \Gamma\left(1 + \frac{1}{\alpha}\right)$$

where Γ is the Gamma function. At typical sites, $\alpha = 2$ is adequate. That corresponds to the Rayleigh distribution. For a mean wind speed of 7 m/s at 10 m hub height, the equivalent at 40 m hub height is [7]:

$$u_{40} = u_{10} \left(\frac{h}{h_{10}}\right)^a,$$

Where: u_h = wind speed at height, h m
 a = Hellman Exponent = 0.14 – 0.17

Let $a = 0.15$, then

$$u_{40} = 7\left(\frac{40}{10}\right)^{0.15} = 8.62 \text{ m/s}$$

Thus $8.62 = \beta \Gamma(1.5)$

And obtaining Γ from standard mathematical tables,

$$\beta = 8.62 / 0.88623 = 9.73$$

thus: $g(u) = 0.021 u \exp(-0.01 u^2)$, $u \geq 0$ (1)

$$P_{aero}(u) = C_p \cdot \frac{1}{2} \rho A u^3 \quad (2)$$

Where $\rho = 1.225 \text{ kg/m}^3$ = density of air, and C_p is the power coefficient.

The dimensionless $C_p - \lambda$ curve is approximated by two piecewise linear curves (see p. 174 of [18]):

$$C_p = 0.18 \lambda - 0.45, \quad 0 \leq \lambda \leq 7$$

$$C_p = -0.04375 \lambda + 0.74375, \quad \lambda > 7$$

Now, $\lambda = \frac{\Omega R}{u}$

For a gearbox ratio of 1:60 and given a slip of -1.7%, generator constant rotor speed of $1500 \times 1.017 = 1525.5$ RPM,

Wind Turbine shaft speed = $\frac{1525.5}{60} = 25.425$ RPM

Therefore, $\Omega = 25.425 \times \frac{2\pi}{60} = 2.66$ rad/s

The assumed rotor diameter = 30 m. Then $R = 15$ m implies that tip-speed ratio, $\lambda = \frac{2.66 \times 15}{u} = \frac{39.9}{u}$

Thus $\lambda = 7$ implies $u = 5.7$.

$$C_p = \frac{7.182}{u} - 0.45, \quad \infty \geq u \geq 5.7 \quad (3a)$$

$$C_p = -\frac{1.746}{u} + 0.74375, \quad u < 5.7 \quad (3b)$$

The expected power generation, $E(P_{aero})$ is:

$$E(P_{aero}) = \int_{u_0}^{u_\infty} P_{aero}(u) g(u) du \quad (4)$$

Therefore, from eqs. (1) to (4), assuming a cut-in wind speed of 3 m/s at 10 m hub-height = 3.69 m at 40 m, and a cut-out wind speed of 15 m/s at 10 m hub height = 18.47 m/s at 40 m, energy captured over one year, $T = 8760$ hours will be:

$$E = 8760 \int_{3.69}^{18.47} C_p \frac{1.225 \pi \times 15^2}{2 \times 1000} u^3 g(u) du \text{ kW}$$

$$E = 3793.08 \int_{3.69}^{18.47} C_p u^3 g(u) du \text{ kWh}$$

Applying (3a) and (3b), $E = E_1 + E_2$ kWh

$$E_1 = 79.655 \int_{5.7}^{18.49} (7.182 u^3 - 0.45 u^4) \exp(-0.01 u^2) du$$

$$E_2 = 79.655 \int_{3.69}^{5.7} (-1.746 u^3 + 0.74375 u^4) \exp(-0.01 u^2) du$$

This gives $E_1 = 5.31 \times 10^5 \text{ kWh}$ and $E_2 = 2.56 \times 10^4 \text{ kWh}$. The total energy per wind turbine is thus $E_1 + E_2 = 5.57 \times 10^5 \text{ kWh}$. The two wind turbines could generate up to $2 \times 5.57 \times 10^5 \text{ kWh} = 1.114 \text{ GWh}$.

III. NETWORK SIMULATION

Fig. 3–8 below show results of the simulation of the network. As can be observed, the results were very satisfactory except for the minimal distortion of the waveforms due to incomplete filtration by the STATCOM transformer.

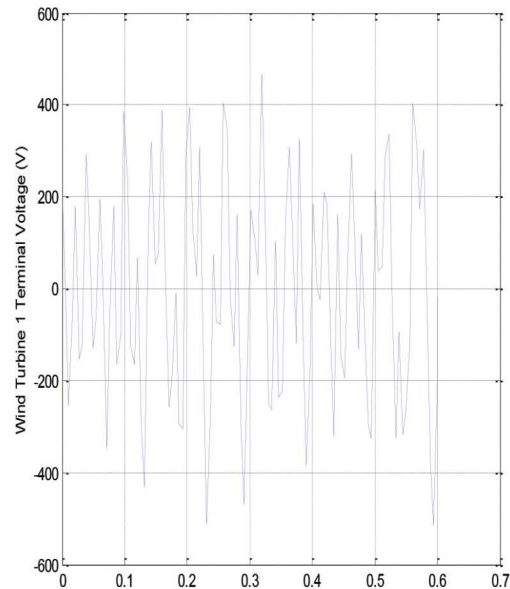

Fig. 3. Wind Turbine Generator 1 Terminal – A-phase Voltage, V

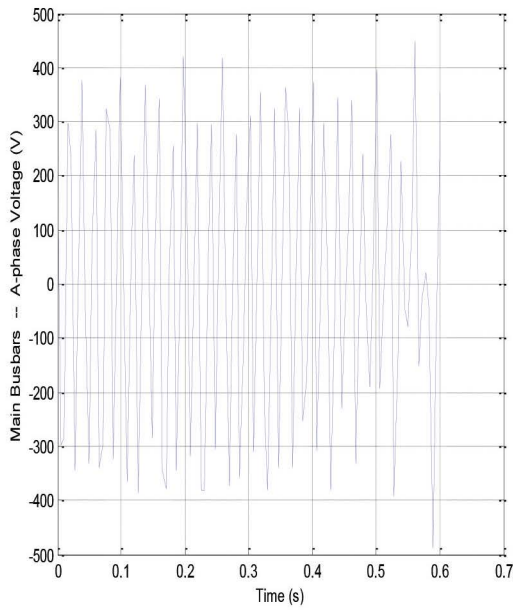

Fig. 4. Main Busbars – A-phase Voltage, V

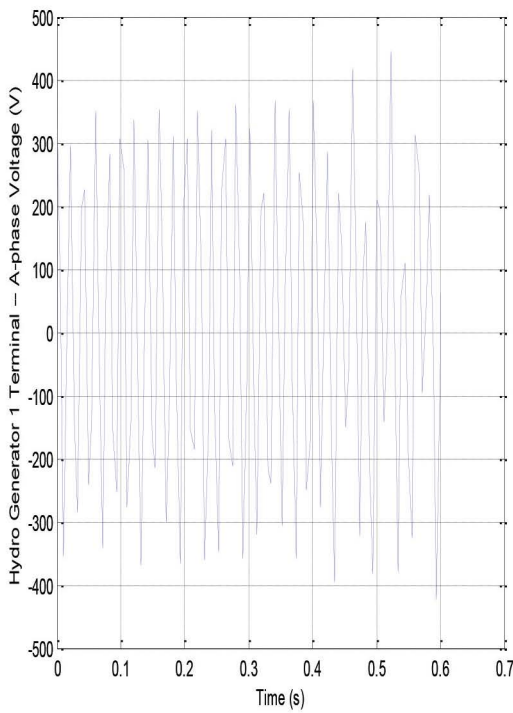

Fig. 5. Hydro Generator 1 Terminal – A-phase Voltage, V

IV. CONCLUSION

Results from this study demonstrate that rural communities in Africa that possess modest wind and hydro resources can benefit immensely from the off-grid hybrid electricity

schemes long before they get connected to their national grids. In particular, in spite of the very moderate wind speeds considered, the potential energy production capability at the WAYA dam site can be seen to have doubled and thus more villages could be connected to the supply than hitherto.

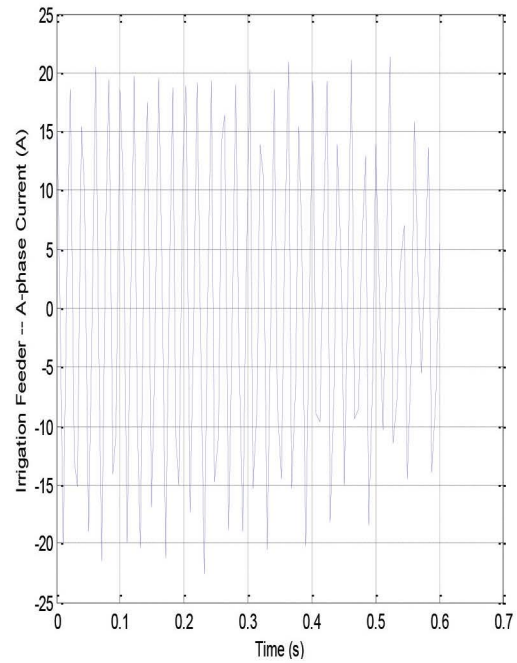

Fig. 6. Irrigation Feeder – A-phase Current, A

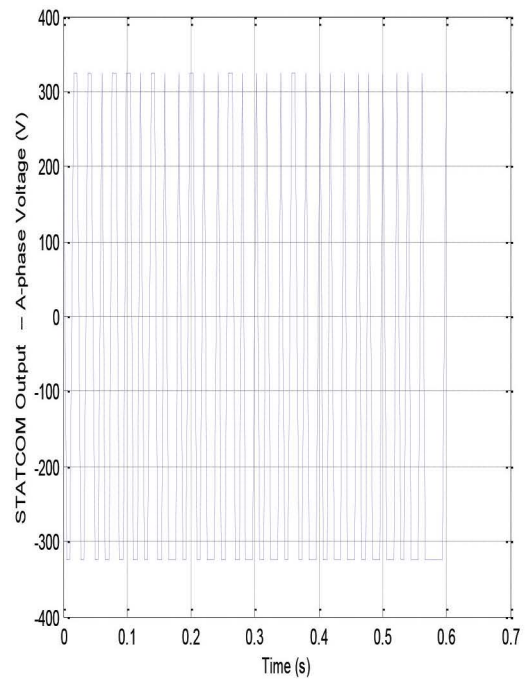

Fig. 7. STATCOM Output – A-phase Voltage, V

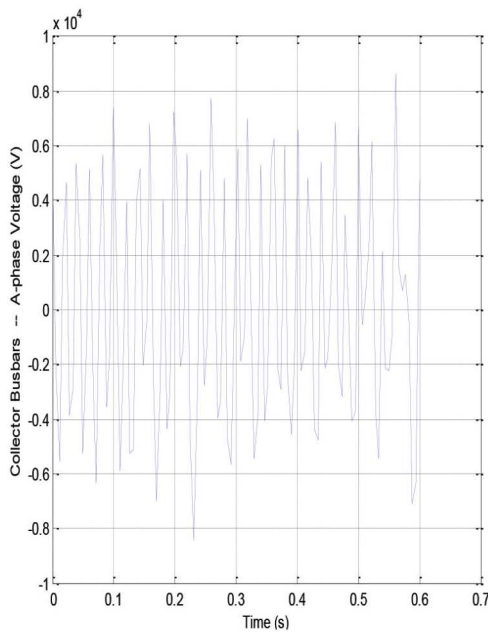

Fig. 8. Collectors Busbars – A-phase Voltage, V

ACKNOWLEDGMENT

The authors would like to thank Mr James Braid, lecturer, and Mr Harry Fellows, Workshop Manager, both of the School of Electrical and Information Engineering, University of the Witwatersrand for their assistance during the tests on the induction motor. The authors would also like to thank Dr A. A. Esan, Technical Director, UNIDO Africa Regional Centre for Small Hydro, Abuja, Nigeria, and his assistant, Dr Adgizi, for, among other things, the provision of documents and technical data of the WAYA dam WAYA project.

REFERENCES

- [1] "Wind farms hit high of more than 12 % of UK electricity demand", RenewableUK (formerly British Wind Energy Association), Jan. 6, 2012
- [2] J. Charles Smith and Brian Parsons, " Wind integration: much has changed in two years ", IEEE Power and Energy Magazine, Vol. 9, No. 6, November/December 2011, pp 18 – 25.
- [3] H. Ibrahim, M. Ghandour, M. Dimitrova, A. Ilinca and J. Perron, " Integration of wind energy into electricity systems: technical challenges and actual solutions ", Elsevier Ltd, Energy Procedia 6 (2010) pp 815 – 824.
- [4] "Grid Code Requirements for Wind Turbines Connected to Distribution or Transmission Systems in South Africa", Draft Rev. 4.4, The RSA Grid Code Secretariat.
- [5] "Connection of Wind Turbines to Low and Medium Voltage Networks", Research Institute for Danish Electric Utilities (DEFU), 2nd ed., October 1998.
- [6] "Specifications for Connecting Wind Farms to the Transmission Network", ELTRA Transmission System Planning, 2nd ed., April 2000.
- [7] Heier, Siegfried, "Grid Integration of Wind Energy Conversion Systems", J. Wiley & Sons Ltd. , 1998.
- [8] C. Carrillo, A. E. Feijoo, J. Cidras, and J. Gonzalez, "Power fluctuations in an isolated wind plant", IEEE Trans. Energy Conversion, Vol. 19, No. 1, March 2004.
- [9] "Waya Dam Small Hydropower Project", by Engr. Mu'Az, courtesy of UNIDO Africa Regional Centre for Small Hydro Power, Abuja, Nigeria.
- [10] L. O. Adekoya, A. A. Adewale, "Wind energy potential of Nigeria", Renewable Energy, Vol. 2, No. 1, pp. 35 – 39, 1992.
- [11] Jamie Taylor, "The Foula electricity scheme ", Northumbrian Energy Workshop Ltd.
- [12] George C. Bakos, "Feasibility study of a hybrid wind/hydro power-system for low-cost electricity production ", Elsevier Ltd., Applied Energy, 72 (2002) pp. 599 – 698.
- [13] S. Papaefthimiou, E. Karamanou, S. Papathanassiou and M. Papadopoulos, "Operating policies for wind-pumped storage hybrid power stations in island grids", IET Renewable Power Generation, 2009, Vol. 3, Iss. 3, pp. 293 – 307.
- [14] O. A. Jaramillo, M. A. Borja and J. M. Huacz, "Using hydropower to complement wind energy: a hybrid system to provide firm power", Elsevier Renewable Energy, Vol. 29 (2004) pp. 1887 – 1909.
- [15] Ross Blakeway, Swiss Energy Solutions South Africa (Pty) Ltd. , Simonstown, Cape Town (private communication).
- [16] "South African Win Atlas ", www.sawa.csir.co.za
- [17] M. G. Say, "The Performance and Design of Alternating Current Machines", Third Edition, CBS Publishers & Distributors, New Delhi, India.
- [18] "Wind Energy Handbook ", T. Burton, D. Sharpe, N. Jenkins and E. J. Bossanyi, J. Wiley & Sons Ltd.
- [19] "ATP Rule Book", Leuven EMTP Center, Belgium, Last Revision Date: June 1992.
- [20] E. D. Bassett and F. M. Potter, "Capacitive excitation for induction generators", Electrical Engineering, May 1935, pp. 540 – 544.
- [21] "ABB STATCOM For Flexibility in Power Systems", ABB Power Systems, Pamphlet No. A02-0165E
- [22] B. Ronner, P. Maibach and T. Thurnherr, "Operational experiences of STATCOMs for wind parks", IET Renewable Power Generation, 2009, Vol. 3, Iss. 3, pp. 349 – 357.
- [23] "Static Synchronous Compensator (STATCOM) for Arc Furnace and Flicker Compensation", CIGRE Publication No. 237, December 2003.
- [24] Bhim Singh, S. S. Murthy and Sushma Gupta, Analysis and design of STATCOM-based voltage regulator for self-excited induction generators ", IEEE Trans. on Energy Conversion, Vol. 19, No. 4, 2004
- [25] "Power Electronics: Converters, Applications and Design", Mohan, Undeland and Robbins, J. Wiley & Sons / IEEE Press.
- [26] "Probability and Statistical Inference ", Robert V. Hogg and Elliot A. Tanis, International Edition, Pearson Prentice Hall, Pearson Education, Inc., Upper Saddle River, New Jersey 074.