

IREJEST IN THIS ISSUE

WWW.irejestjournal.org

ISSN: 1597 -5258

TABLE OF CONTENT

VOL. 4 NO. 1 2007

	Page
1. Design and Construction of A Hybrid Broadband and Antenna. Sunday, A.A, Ekpo S.C, Udoanya E.O, Wara S.T and Orowode, H.E.....	1-5
2. Analysis of Loads and Deflections in Coupled, Shear Walls of Multi Storey Buildings. C.A Chidolue	6-13
3. An Appraisal of Mine Drainage System in Akouta Uranium Company, Niger Republic. Akande J.M	14-19
4. Improving The Accuracy and Reliability of Preliminary Estimate of Construction Project using alternative Costing Method. Oyoh A.J and Okonkwo C.....	20-24
5. Computer Simulation for Determination of the Suitability of Nigerian Coal as Alternative Fuel for Blast Furnace Process. Olubambi P.A. and Oluwadare G.O.	25-32
6. A Comparative Study on the Bioagass Yields from Cow Dung, Poultry Droppings and Cow Abdonunal Wastes. Ogbuagu J.O and Igbokwe P.K.....	33-40
7. UV Degradion of Polypropylene Containing Pro Degradants. G.N Onyeagoro	41-46
8. The Selection of Contract Types and Effect on Project Cost. Oyoh Azubuike John and Okonkwo Chibuzo.....	47-52
9. A Pressure Apparatus for the Determination of Porosity of Unconsolidated Agricultural Materials. C.N. Madubuike.....	53-61
10. Determination of Ground Vibrations and Levels During Blasting Operations. Akande J.M and Ifelola, E.O.....	62-69
11. Computational Industrial Energy need for Nigeria (Electricity, Fuel, Oil Coal Conservation and Solar Thermal Application). P.C.E. Njoku.....	70-76
12. Considerations, Gains and Challenges Facing The Deployment of Free Space Optics in Nigeria – F.K. Opara	77-82
13. Effects of Varying Rainfall Intensities on Selected Soils of South –Eastern Nigeria Using Simulated Rainstorms. C.N. Madubuike.....	83-91
14. Influence of Drilling Mud in Water Borehole Drilling. J.M. Akande.....	92-98
15. Commercial Energy Demands For Agricultural Operations in Nigeria. P.C.E. Njoku.....	99-105
16. Design, Construction and Simultation of an Electronic Water Level Controller, S.T. Wara, H.E. Orowode and Mohammed O. A.....	106-116
17. A Comparative Study of the Effect of (Natrosol Hydroxyethylcellulose) and Local Thickener (Starch From CassavaTuber) on the Physical Properties of Emulsion Paint. Oyoh K.B and Nnamchi S.N.....	117-129
18. Environmental Impact Assessment of Heavy Metals In used Engine Oil and Gasoline – Ogbuagu J.O. and Anya I.....	130-140
19. Diffusion of Methanol, Ethanoland Toluene in Nylon 12 and Poly (Ethylene Terephthalate). G. N. Onyeagoro.....	141-147
20. Trace Elements and Microbial Contamination of Canned Foods in the Nigerian Market, Ogbuagu J.O.	148-154
21. Fate of Trace Element Emission in Coal Combustion - B.C. Udeh and L.E. Aneke.....	155-164
22. Criteria for evaluating the effectiveness of bar charts scheduling technique for a public building project delivery C.I. Anyawu	165-172

**DESIGN, CONSTRUCTION AND SIMULATION OF AN
ELECTRONIC WATER LEVEL CONTROLLER**

S. T. WARA. , H. E OROVWODE

*(Electrical/Electronics Department, College Of Engineering, Igbinedion
University Okada Edo State Nigeria)*

And

MOHAMMED O.A

*(Electrical/Electronics Department, Faculty of Engineering University of Uyo
,Uyo Akwa Ibom State Nigeria)*

ABSTRACT

In order to preserve the life of water pumping machine as well as convenience of operation, an Electronic water level controller was designed, constructed and simulated to operate in two modes: manual and automatic. The design analysis was based on simple circuit theory leading to the specification / choice of components used for the construction of the controller. The technical features and cost of the unit are very encouraging. The unit can be easily maintained and is rugged.

KEYWORDS: *Controller, Electronic, Simulation, Mode, Level, Water;*

INTRODUCTION

Several ways of level control include pneumatic, mechanical, electrical and electronic. Most of the above mentioned level control systems have become obsolete, while electrical level control devices are still very common. We are now in the electronics age and electrical control systems are also gradually being replaced with their electronic equivalent. Electronic systems are gaining ground because of the low power requirement, reduced cost, size and weight. Efficiency, reliability, versatility and comfort are also associated with electronic system.

The electronic water level controller designed and constructed provides accurate level control with indicators to monitor the state of the pump, well and overhead tank water level as well as audible warning device to alert

the user. This is a rare feature in the existing controllers.

The design is based on the following basic factors among others.

- (i) Water in its pure state hardly conducts electrically. Only 10^{-7} gram per one litre of pure water dissociates under impressed current (Wilkinson, B. (1987)). Underground (well) and treated public supply water is never pure and
- (ii) Does not conduct electricity appreciably. Hence, inexpensive electrode-type level sensors are used instead of the usual float switch.
- (iii) Transistor can be operated from cut-off to saturation or vice versa at enormous speed. Under this condition, a transistor is referred to as an electronic switch that provides high or low logic required by a logic circuit.
- (iv) Operational amplifiers can be configured to be a comparator which could compare the value of a varying voltage with a fixed reference voltage.

- (v) Logic gates could be used to carry out decision making in an electronic circuit.
- (vi) Finally, a flip flop circuit in the form of integrated circuit can favourably replace an analog feedback circuit used in most automatic control circuit. This versatile controller can be used for a single or three phase pump: surface, dip or submersible types. Areas in which the device can be used include: bore-holes, domestic and public water supply systems as well as chemical water treatment plants. With slight modification, non-conducting liquid (like oil) level can be controlled by the device thus extending its area of application to the oil and gas industry.

METHODOLOGY

The design of the controller is divided into two major breadings: the power supply unit and the control unit.

Power Supply Unit

Like all other electronic device, the electronic water controller needs power supply to enable it operate. The use of battery is not very appropriate because of degenerating emf during service life (Harbst, L. J. (1969) and most importantly is the fact that the pumping machine used in an AC induction motor.

The power supply unit is made up of a step down transformer, rectifier and filter. The block diagram of the power supply unit is shown in Figure 1.

The peak voltage output of the rectifier is given (Harbst, L. J. (1969) as:

$$V_{p'} = V_p + V_F \dots \dots \dots (1)$$

$$\text{Where } V_p = \sqrt{2}V_{rms} \dots \dots \dots (2)$$

V_F is the forward voltage drop of the rectifier diode

The voltage output of the rectifier is not pure d.c. it contain large alternating components called ripple. The ripple voltage ΔV can be expressed as:

$$\Delta V = \Delta Q / C \dots \dots \dots (3)$$

$$\Delta Q = I_{dc} \times T / 2 \dots \dots \dots (4)$$

$$\Delta V = I_{dc} \times T / 2C \dots \dots \dots (5)$$

$$\text{But } F = 1/T$$

$$\text{Therefore } V = I_{dc} / 2FC$$

The unregulated d.c. voltage from the rectifier is not constant and therefore not suitable for the device operation due to the following reasons (Millman and Hakias (1972)☺

- (i) D.C. voltage decrease with increase in load current
- (ii) The DC voltage varies with temperature, particularly because semiconductor devices were used.
- (iii) DC. Voltage varies with an ac input.
- (iv) Components is the unit were selected based on a nominal voltage value hence a variation in the value of the voltage could make the circuit malfunction.

It is therefore imperator that some form of regulation be used. The change in output voltage ΔV_o of a power supply can be expressed as follows:

$$\Delta V_o = S_v \Delta V_i + R_o \Delta I_L + S_T \Delta T \dots \dots (6)$$

Where these three coefficients are defined as input regulating factor

$$S_v = \frac{\Delta V_o}{\Delta V_i} / \frac{\Delta T}{\Delta I_L = 0} \dots \dots \dots (7)$$

Output Resistance $R_o = \frac{\Delta V_o}{\Delta I_L} / \frac{\Delta T}{\Delta V_i = 0} \dots \dots \dots (8)$

Temperature co-efficient $S_v = \frac{\Delta V_o}{\Delta T} / \frac{\Delta I_L}{\Delta V_i = 0} \dots \dots \dots (9)$

The electronic water level controller uses two voltage levels: a positive and a negative hence the power supply used is a dual supply and makes use of integrated circuit, three terminal regulators 7812 (for positive) and 7912 for negative.

1. From RS component catalogue and MAPLIN professional (RS Component Catalogue. (1997), MAPLIN Professional (1997)) the parameters of the voltage regulators (7812, 7912) are

- I_L maximum = 1.0A
- $V_{out} = 12V$
- V_{in} minimum = $V_{out} + 2V = 14V$

From the above analysis, a step down transformer that could produce the 14V. is the 15V centre taped transformer that a current rating of 2.0A giving a VA rating of 30. Figure 2 shows the power supply block diagram and the wave form at different stages and Figure 3 shows the circuit diagram.

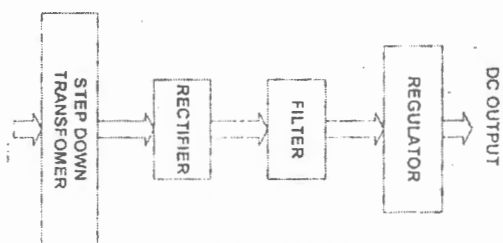

Fig 1 Power Supply Unit Block Diagram

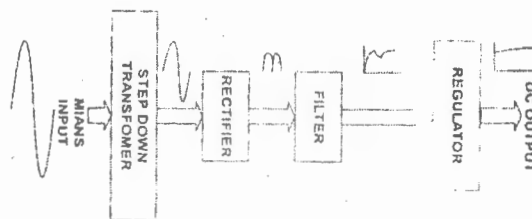

Fig 2 Power Supply Unit Block Diagram and the Associated Waveforms

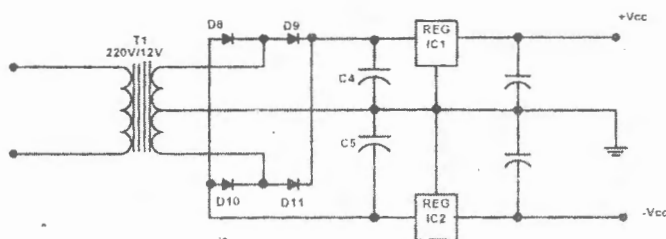

Figure 3 Power supply unit circuit diagram

CONTROL UNIT.

The control circuit is divided into six segments; level sensor, comparator unit, logic circuit, switching, relay circuit and audible warning device (AWD).

Water Presence Sensor

The conductance of water depends on several factors among which are (Walkers, R. (1978))

- (i) Concentration (PH level): Natural water is not pure; it contains bicarbonate of calcium and magnesium among other salts. Conductance of water may also increase due to metallic impurities absorbed during distribution through pipes. The implication of this is that water can conduct electricity.
- a. Temperature: increase in temperature raises the potential of a molecule such that it can dissociate easily when current is applied. Conductance of water therefore increases with increase in ambient temperature.
- (ii) Applied voltage. The conductance of water increase as the voltage applied increases.
- (iii) Anode – Cathode Distance: the experimental set-up for testing the conduction of water under ambient temperature is shown in Figure 4. If the anode is far from the cathode many carriers will be lost in transits. To obtain higher conductance, anode and cathode must be as close as possible about 3mm apart.

The readings obtained from the experiment carried out to test

the conductance of water is tabulated in Table 1 and using the expression of equations (10) and (11) below the resistance and conductance could be obtained from the graph of Figure 5.

$$R = V/I \dots\dots\dots (10)$$

$$\sigma = 1/R = I/V \dots\dots\dots (11)$$

When the electrodes are shorted with water the resistance value is as obtained from equation (10). When there is no water, the resistance is infinity. The resistance of the electrode is connected in series with another resistor to form a voltage divider network. By this connection, the voltage of the connecting point of the resistance and the electrode is zero when there is no water and a value of 6V when there is water. The value of the resistance is calculated as

$$\frac{V_{out}}{XR \dots\dots\dots (12)} = \frac{6V}{R + R_w} = \frac{V_{cc}}{R + R_w}$$

Where R_w is the resistance of water, R is the series resistance
The sketch of the network is as shown in Figure 6.

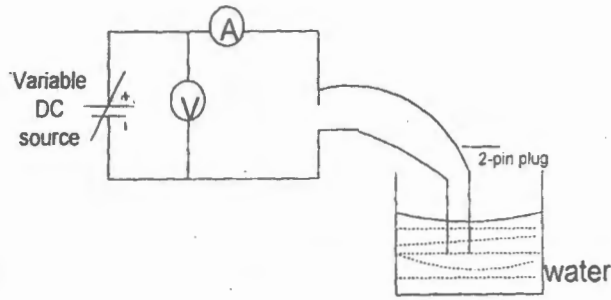

Figure 4 Apparatus for water resistance test

Table 1 : Water conductance test result

S/N	Impressed voltage (V)	Current (mA)
1	5	2.24
2	10	4.46
3	15	6.56
4	20	8.80
5	25	11.14
6	30	13.32

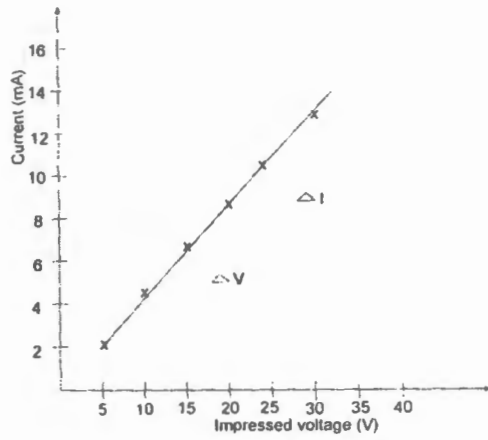

Figure 5 V- I characteristics curve of tap water

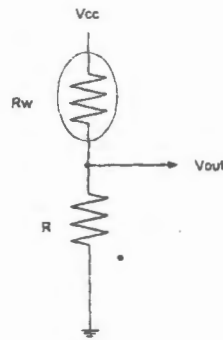

Figure 6 voltage divider network

The Comparator Unit & Tank Indicators

The voltage from the water sensing unit is compared with a reference set by a variable resistor. These voltages are fed to the inputs of an operational amplifier. The comparator produces two outputs levels i.e. +Vcc or -Vcc depending on which of the inputs have a higher potential. The reference voltage is set at 4V since the sensor voltage changes between 0V and 6V.

Diodes are connected at the outputs of the operational amplifiers so that should the output go negative, current would not flow in the reverse direction from the circuit connected to it. Two indications were connected to monitor the tanks condition. One on the overhead while the other at the underground (reservoir). The indicator comes 'ON' when there is no water. They act as visual indicator of the tank condition.

The Logic Circuit

The outputs of the comparators have to be combined to give a definite instruction either to START or STOP the water pump.

The following are the conditions that must exist:

Comparator 1: the motor (water pump) can only start to run when there is water in the reservoir tank and no water overhead.

Comparator 2: the motor should be stopped when the overhead tank is filled or the water in the reservoir finishes.

These conditions are combined using two logic gates; they are 2 - input NAND Schmitt trigger (4093) and 2 input OR Gate (4001).

Comparator 1 produces '1' when the overhead tank is filled and '0' when less than maximum level.

Comparator 2 produces '1' when overhead tank is empty and '0' when there is water in the overhead tank.

Comparator 3 produces '1' when reservoir is empty, '0' when there is water in the reservoir.

Therefore for the motor to start, comparator 2 should be '1' and comparator 3 should be '0' while for the pump to stop comparator 2 should be '1' or comparator 3 should be a '1'.

Switching Circuit

The switching 'ON' or 'OFF' of the pumping machine is controlled by a high and a low signal from the output of a bistable multivibrator built using the monolithic 555 timer IC.

The bistable is SET when it receives a high signal from the start output of the logic unit and its output then goes high. On the other hand, it is RESET to low when a high signal comes from the stop terminal of the logic unit.

It should be noted however that only a low going pulse that can be used to set or reset the flip flop hence the pulse from either the start or stop needs to be inverted before applying it to pin 2 and pin 4 for set and reset respectively.

The transistors Q1 and Q2 are used for trigger and reset respectively. The base resistance and collector resistance are derived from equations 13, 14 & 15.

$$R_B = (V_{CC} - V_{BE}) / I_B \dots \dots \dots (13)$$

$$I_B = I_C / \beta \dots \dots \dots (14)$$

$$R_C = (V_{CC} - V_{CE}) / I_C \dots \dots \dots (15)$$

The output of the flip flop (pm3) is used to close current path to the relay coil which attract the pole of a normally open relay to close. The closure of the relay completes the circuit for the coil of the main contractor which in energized to closed contact and power is made available to the water pump to start pumping

The Audible Warning Unit (AWD)

The alarm is triggered ON when there is no water in the reservoir. The purpose of this is to alert the user to make necessary preparation and provision for more water before the one overhead finishes.

The alarm is expected to blare for a period of time to avoid it constituting nuisance. The timer for the alarm is built using the monolithic 555 timer IC configured in the monostable mode. The period of the timer is given by

$$1.1R_t C_t \dots \dots \dots (16)$$

The alarm was build using the same 555 time IC but configured as a free running (astable) multivibrator, two of such multivibrators were used. The first is the tone generator which runs at a frequency of 1.5 kHz while the second is used to modulate the first and runs at a frequency of 1Hz. The expression for the frequency of the 555 is given by equation 17 as

$$F = \frac{1.44}{(R_a + 2R_b)C} \dots \dots \dots (17)$$

Since the two oscillators are free running, the output of the monostable is used to close a relay which supplies power to the oscillators and cut off supply after the timing period. Figure 7 shows this arrangement.

The output of the oscillator is amplified to be able to drive a speaker effectively. The speaker used is a 1W, 8Ω voice coil speaker. Transistors Q₄ and Q₅ are connected as a Darlington pair to provide the necessary amplification.

The circuit gain of the pair can be expressed as (Jones, M. H. (1977). Millman and Hakias (1972))

$$h_{fe} = h_{fe4} + (1 + h_{fe4}) h_{fe5} \dots \dots \dots (15)$$

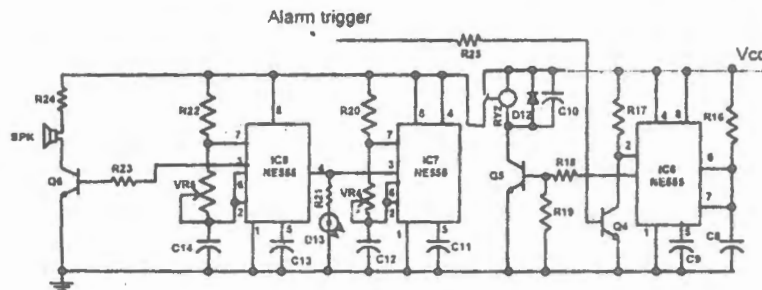

Figure 7 audio warnnig unit

The complete circuit diagram of the controller is shown in Figure 8

RESULT, DISCUSSION, SIMULATION AND TESTING OF THE CONTROLLER

The constructed controller was simulated using a domestic water system having a 1.5HP surface pump. 5feet (1.5m) high overhead tank placed on a stand of 12ft high (3.6m) and a reservoir of 5 feet (1.5m) deep below ground level. The installation of the pump, tank and reservoir were completed. The level sensors (probes) were (TH) overhead upper level, TL as overhead lower level and WL underground reservoir.

WL was placed about 4 inches (100mm) above the suction to enable the pump motor stop running before the water level in the reservoir falls below the suction level in order to protect the pump against cavitation (running dry)

(www.Waterpumpbiz.com)

The TH sensor is positioned at a level 2inches (50mm) below the tank total height to avoid overflow of water. Finally, the TL sensor was positioned at 2 inches (50mm) above the over head tank discharge point. The system was tested and the performance was satisfactory.

OPERATING THE CONTROLLER

When installed and the power switch (S) is put on, the system runs automatically. However, if there is need for manual operation, the start and stop switches could be used. It must be noted that the manual switches can operate only if the condition for the pump to start or stop exists. The conditions are:

The start button will operate the motor if there is water above WL in the reservoir and there water less than TH in the overhead tank. The stop will operate when there is water above TL in the overhead and irrespective of the condition of the reservoir.

CONCLUSION

The electronic water level controller provides sufficient flexibility to enable a wide range of application. The device can be used for both single and three phase water pumps of various with suitable choice of contractor. Submersible, dip or surface pump can be controlled with no loss of quality and reliability.

Also, the inexpensive electronic water level controller has been designed and constructed using commonly available components which makes maintenance of the device easy.

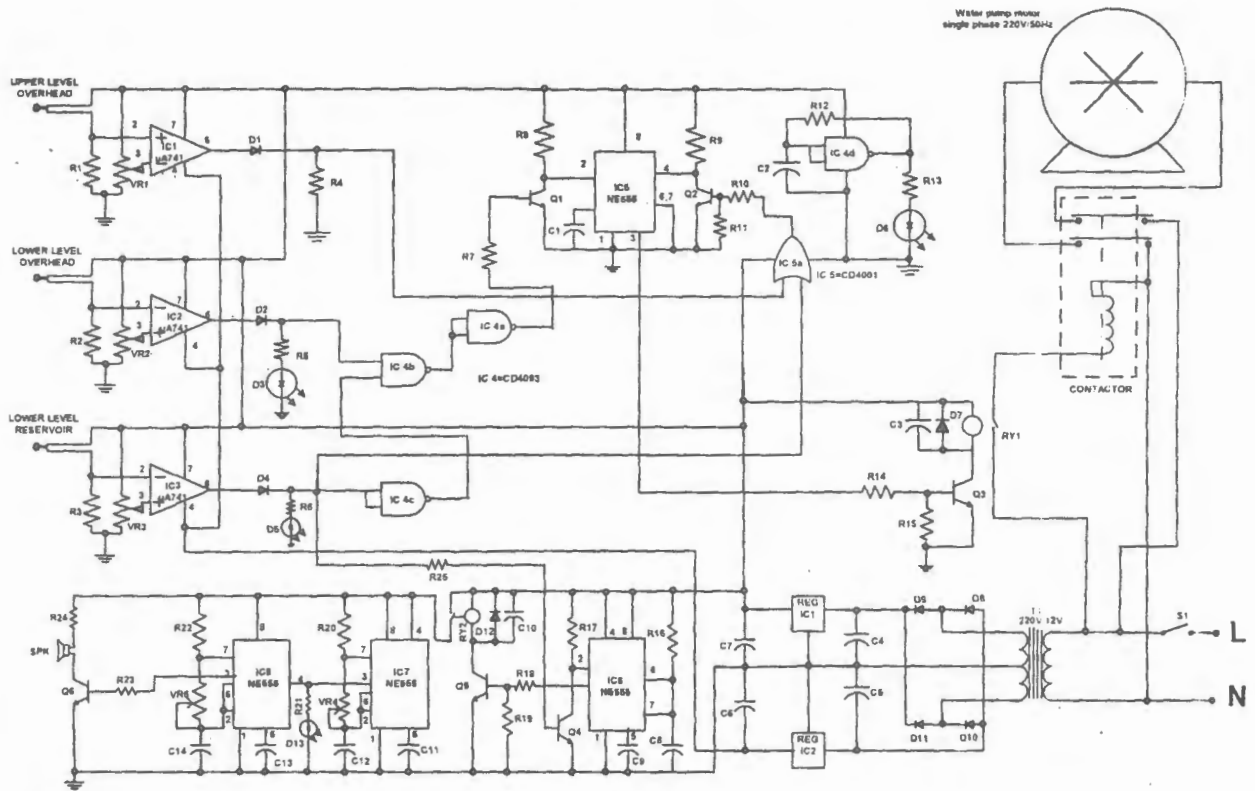

Figure 8 Complete circuit diagram of the Automatic Water Pump Control System

Indicators are provided by the device for the state of pump (whether running or not), minimum well water level and minimum and maximum water levels in the overhead tank. Some of these features are not provided by many other level control devices.

Although, the device has originally been designed for conducting liquids, but with slight modification of the sensors, it can be used to control the levels of non-conducting liquid. The device can be categorized as an appropriate technology.

NOTATIONS

V	-	Voltage
I	-	Current
F	-	Frequency
C	-	Capacitance
T	-	Period (1/f)
R	-	Resistance
Q	-	Charge
V_p^i	-	Peak rectifier output voltage
V_p	-	Peak transformer output voltage
V_F	-	Rectifier forward voltage drop
V_{rms}	-	Root mean square voltage
ΔV_0	-	Change in output voltage
ΔV_i	-	Change in input voltage
ΔT	-	Change in temperature
ΔI_L	-	Change in load current
S_v	-	Input regulation factor
S_T	-	Temperature coefficient
Σ	-	Conductance
LED	-	Light Emitting Diode
I_b	-	Base Current
I_c	-	Collector current
h_{fe}	-	Current gain
V_{cc}	-	Collector voltage
V_{CE}	-	Collector-Emitter Voltage
V_{BE}	-	Base-emitter voltage
R_C	-	Collector resistance
R_b	-	Base resistance
TH	-	Tank high
T_L	-	Tank low
W_L	-	Well level

REFERENCES

- Catalogue of discrete semiconductor, Quarandon Electronics.(1998)
- Forrest, M. M. (1980): "A handbook of integrated circuit Application" Radio Shack. Pp. – 94.
- Harbst, L. J. (1969): "Discrete and Integrated Semiconductor Circuitry", Chapman and Hall. Pp. 42.
- Jones, M. H. (1977): "A practical Introduction electronic circuits". Cambridge University Press. Pp. 107 – 110
- MAPLIN Professional (1997): The complete catalogue for Electronics. Pp. 537-541.780..
- Millman and Halkias (1972): "Integrated Electronic", McGraw Hill Inc. pp. 698-700
- RS Component Catalogue. (1997)
- Wilkinson, B. (1987): "Digital System Design", Prentice hall International Ltd Pp. 30-39 512-542.
- Walkers, R. (1978): "Water Supply Treatment and Distribution". Prentice Hall.
- www. Waterpumpbiz.com