

Remote Monitor and Controller System for Power Generators.

A.U. Adoghe, MNSE, MIEEE* and I.A. Odigwe, MNSE, MIEEE, MIET

Department of Electrical and Information Engineering, College of Science and Technology,
Covenant University, Ota, PMB 1023, Ota, Ogun State, Nigeria.

*E-mail: adoghe_tony@yahoo.com

ABSTRACT

Stand-alone power generating sets have become a source of alternative power supply in Nigeria for decades now, especially for business owners, corporate bodies, industries, as well as individuals, due to the epileptic condition of the electric power utility. The proper management, as embodied in the control and maintenance of such systems, has remained a source of concern as power failures are critical to the productivity of such users, especially industries and businesses.

In this paper, a Remote Monitor and Controller System (RMCS) for power generators is designed to improve the operation and maintenance of power generators. The RMCS, which includes both a hardware module and software, provides a functionality that allows a power generator to be controlled and monitored from a remote location.

(Keywords: controller, generator, remote, monitor, automatic, power systems)

INTRODUCTION

The essence of engineering and technology is typically to create products that make life easier for mankind. Remote device control is one technology that has evolved over the years and has brought about more convenient ways of controlling equipment, machines, and devices. It could be applied to electronic, electrical, or mechanical devices. Remote device control involves making changes or setting a device in place to make the subject equipment behave in a desired manner without having to be at the local station where the device resides. The Remote Monitor and Controller System (RMCS) is an electronic intelligent system that offers an efficient and convenient way of monitoring and controlling automatic power generators.

Electric power system in Nigeria have suffered instability over the years. This has moved individuals, industries, government agencies, and corporate bodies to opt for standby power generators as an alternative power supply system, to increase the availability of electricity for their business operations. The common choice of standby power generation system is the automatic power generator with diesel or other fuel engines. Most modern generator systems includes not only the standby generator but also the automatic transfer switch (ATS) that allows for automatic change of the source of power supply between the conventional utility supply and the standby generator, output distribution, etc. However, the management system remains a core challenge.

The time lag between when the mains supply is off and when the standby power generator is on is usually long due to the processes involved and the human interactions that take place before the standby power generator is switched on. Time means money, especially for business owners. The operation of the power generators requires much human interaction in switching (ON/OFF) and in monitoring the safety and control conditions that must be met before automatically starting the standby power generator. With the RMCS system, these human interactions that results in delay are eliminated.

The health hazards associated with noise in the generator environment will also be eliminated if most of the monitoring is done remotely. Most often maintenance actions are not properly scheduled because of lack of efficient monitoring process that ensures accurate and efficient maintenance timing. The need to develop a system that ensures effective management and operation of standby power generators has therefore influenced the motivation for this project work. The following were developed in order to achieve the desired project objective:

- Building of the RMCS hardware module – The RMCS hardware module is a microcontroller based device that provides a connection between remote PC (personal computer) and the power generator system. It communicates with PC via the serial port and receives regulated voltage signals from the power generator via a relay circuit.
- Application development – This refers to the development of a desktop application that provides a graphical user interface (GUI) through which the user can control or monitor the generator system. The application will be installed on a remote PC from where the control commands will be issued.

The expected outcome of this work is to monitor the operational status of a power generator system and then start it from a distant location.

METHODOLOGY

This project involves building a hardware module and developing an application. The hardware module comprises three stages: Serial Level Converter, the relay interface, and the microcontroller stage. The serial converter changes the RS232 level to a lower one for serial communication [1]. The relays interfaces serve as switches between the power generator and the microcontroller.

The control actions are actually performed by the microcontroller. It processes the signals (requests) that are inputted from the computer as well as the observed operating conditions from the power generator system. The microcontroller is programmed to take in input signals from the computer as well as the input signals from the Generators via various sensors [2]. The output section of the microcontrollers is connected via relays for the desired operational actions. The stages involved in this design are shown in the block in figure1.

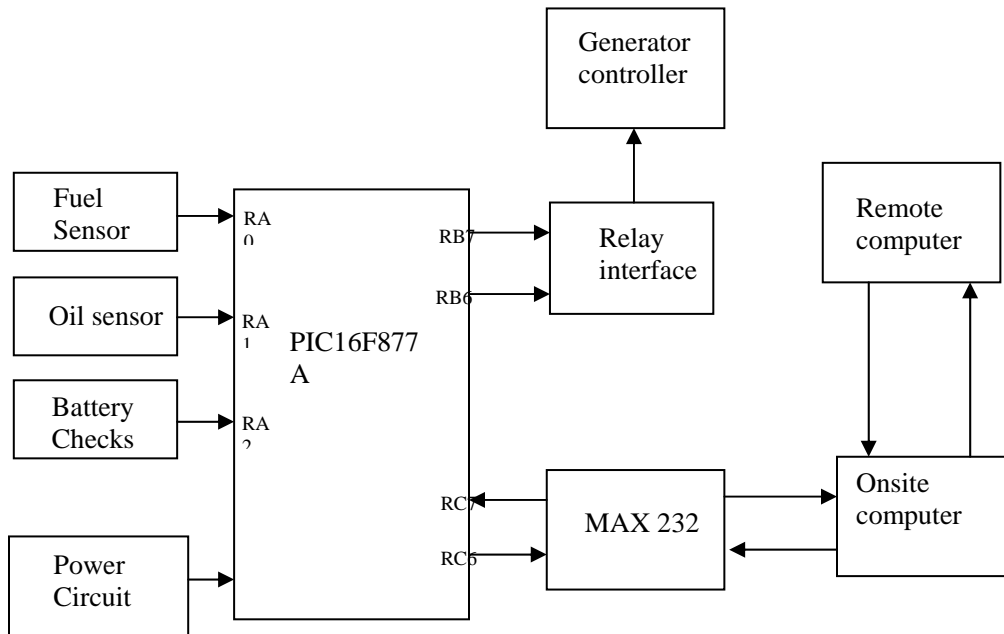

Figure 1: Block Diagram of RMCS.

The PIC is programmed using C language. The compiler has a USART Library that allows for serial port programming in C [3]. The desktop application GUI is developed using Microsoft Visual Basic 6.0®. It has a communication control (MSCOMM) that provides access to the serial port for communication purposes.

The analysis and design of the RMCS is divided into three sections: the power supply unit, the interface between the application PC and microcontroller, and the interface between system and the power generator. The hardware module is interfaced with the meters or level measures on the power generator for monitoring purposes and it is interfaced with the PC through the Universal Synchronous Asynchronous Receiver Transmitter (USART) on the PIC and the serial port (on the PC) [4]. The block diagram in Figure 2 illustrates

the working principles of the RMCS and some of the critical components used in the design.

The power supply is designed to incorporate LM7812 and LM7805 as the voltage regulator IC which have black plastic bodies with metal tab heat sinks. A hole is provided in the metal tab for mounting but this tab is electrically connected to the center pin which is the output pin. The input pin is on the right side and the adjustment pin is on the left [5]. Fixed regulators such as the LM7812 (12 volt) need no resistors and may be mechanically grounded without insulation since the tab is internally connected to ground. Either way, these three-terminal regulators perform well and offer built-in current limit and thermal overload circuitry. Care is taken to include the input and output capacitors as shown in Figure 3, and mounted near the regulator IC.

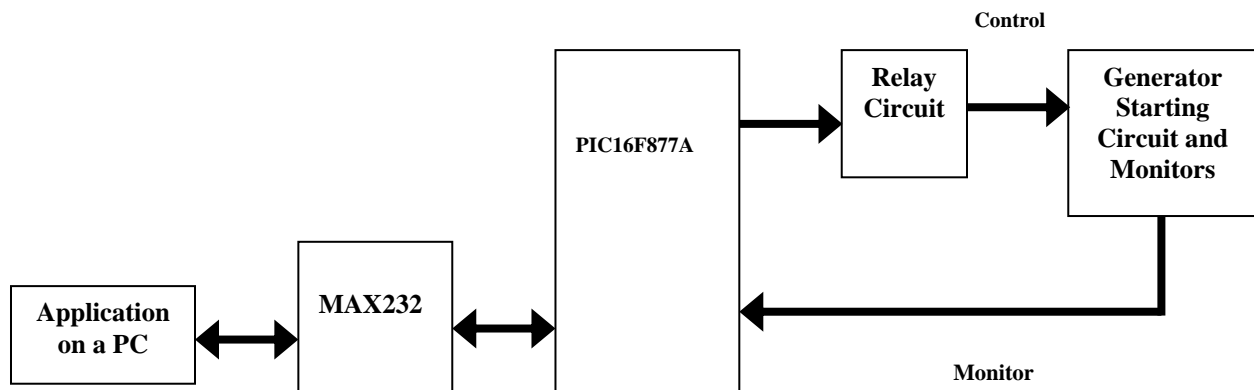

Figure 2: Block Diagram Showing the Working Principle of RMCS.

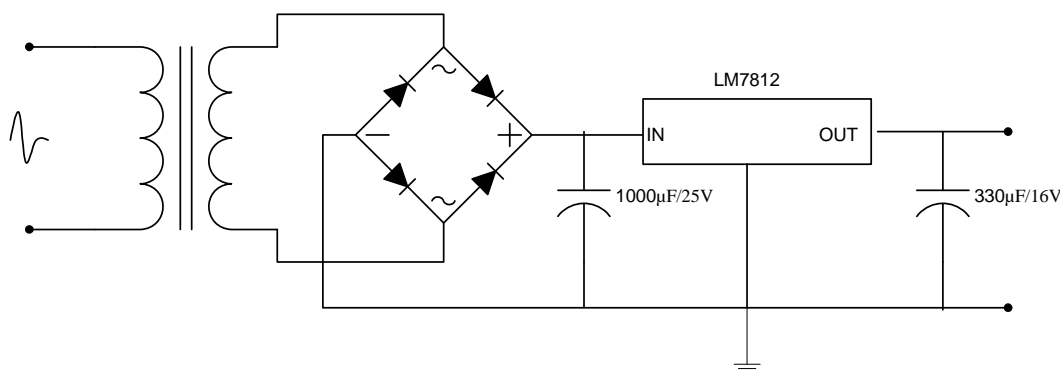

Figure 3: Power Supply Regulator.

RESULTS AND DISCUSSION

The design of the RMCS provides a two-way functionality as shown in Figure 2 above, a forward functionality from the PC to the generator and a backward functionality from the generator to the PC.

Forward Functionality (Control)

The control of the RMCS system starts from the application on the PC, as shown in Figure 2, which sends signals in voltage ranging between -15V DC to +15V DC through a serial communication port (RS-232) to MAX-232. The function of the MAX-232 is for communication between the PC and the microcontroller (PIC 16F877) by reducing the voltage signal ranging between 0V DC to +5V DC which is sent to the input pins on the PIC which in turn sends signals to the generator via the relay circuits. The signal from the PIC output is not sufficient to energize the relay (PIC provides 25mA maximum, relay requires 100mA minimum), an amplifier using an NPN transistor technology was used to amplify the current to a level sufficient to energize the relay. When a logical one is delivered to transistor base, the transistor activates the (ON) relay. The relay circuit once energized closes the normally closed contact which triggers the solenoid of the

Generator's starter switch that turns on the Generator.

Backward Functionality (Monitor)

This is the part of the system that process the various input signals from the different monitoring points. (such as fuel level, oil level, and battery power). The monitoring device operates as follows, when the fuel level is set at +5V DC, the fuel level is full and when it is 0V DC, the fuel is empty. This is made possible through an NPN transistor circuit which sends the signal in binary form of logical '0' and logical '1' ('0' for empty and '1' for full) to port A on the PIC. The MAX-232 and the serial port on the other hand is set between -15V DC and +15V DC signals which back the application on the PC (i.e. when it is -15V DC), the fuel level monitor on the application indicates RED light which shows it is empty, and when it is +15V DC, it indicates GREEN light which shows the fuel level is full. The monitoring devices are connected in series on the circuit board (shown in Figure 4) in a normally closed contact form such that if any of the parameters is empty the system is open circuited thereby making it impossible for the generator to be switched on [6]. The Generator can only be switched on when all of the conditions are not violated.

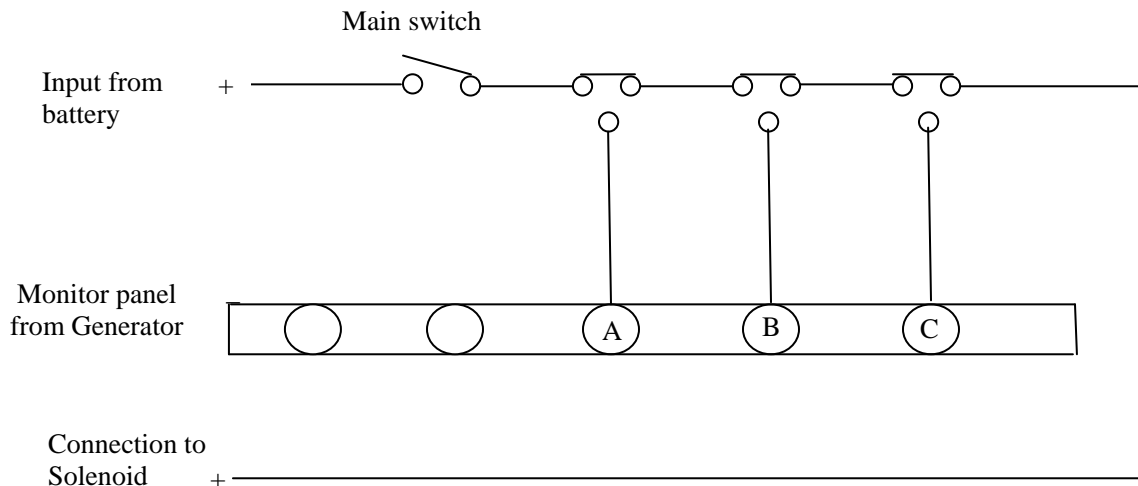

Figure 4: Switching and Monitoring Panel.

The functionality of the RMCS has to do with communication between hardware and software. The RS-232 standard (serial port) provides the communication standard required. Hardly any measurement instruments are designed to use the RS-232 interface, since it lacks the speed and flexibility of the IEEE-488.2 bus [7]. However, for specific applications, such as reading data from remote DC sensors and sending data to loggers, it can be very useful. The PIC is the basic device that the application communicates with, but the signal generated by the serial port cannot be understood by the PIC without a conversion.

PC Application Development

The software part of the RMCS package is developed using Microsoft Visual Basic 6.0® (VB6). The choice of VB6 is because of its ease of use and familiarity with the language. VB6 is an event-driven programming language that has many elements of an object-oriented language such as Java. Event-driven means that the program is not procedural (does not follow a sequential logic) hence the sequence of execution is not predetermined but rather users can click buttons in the program window to determine next procedure to execute. Each user actions can cause an event to occur [8].

An application is developed using VB6 by putting controls on forms and linking forms together. The MSCOMM control is used for serial communication, it is activated (the OnComm event of MSCOMM) when the timer control is activated at the instance of the command button linked to it. The OnComm event of the MSCOMM sends the pre-defined hexadecimal number through the serial port [9]. The OnComm event also retrieves information (in hexadecimal value) on the status of the power generator parameters and changes the color property of the labels used by the monitor aspect of the application based on the received byte.

At startup, the program attempts to determine and open the PC Com (serial) port available for communication by checking the next com port when error is encountered in opening the first (or previous) Com port. The program can check up to four different Com ports available on the PC. Also, at startup, the program reads the data file on the C drive that stores the pre-set maintenance date. If the program is being used for the first time on that PC, the data file is created on drive C when

the maintenance time is set and the set date is stored on the file so that it could be read anytime the program starts. From the application, the maintenance scheduling can be performed manually by choosing a date on the calendar provided in the application or automatically by allowing the system to calculate the date based on the hours of running of the generator system.

MAX232 is an IC designed to convert between serial and logic voltage levels [10]. RS-232 standard works with voltage range of -15V to +15V for low and high states while TTL logic operates between 0V and 5V which is the voltage levels that can be handled by PICs [11]. The IC has the capability to change the serial voltage level output from the PC to the logic level input into the PIC and also convert the logic level output from the PIC to serial level input into the PC. The IC works with a 5V power supply and transmits data through its 2-RS232 drivers/receivers at 120Kbps.

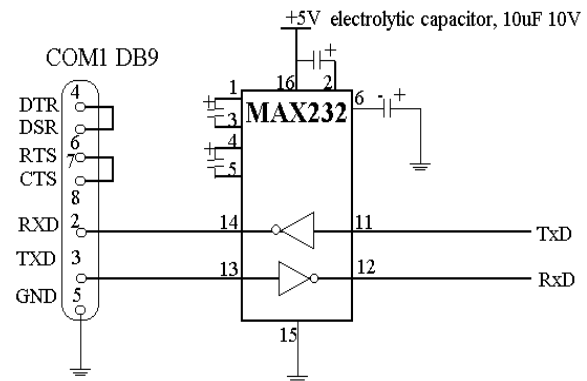

Figure 5: MAX232 Serial Converter.

Microcontroller PIC16F877A

This implements the software based control and monitoring processes. The PIC has an addressable USART which it uses for serial communication with the MAX232. The PORT B of the PIC is configured as the output that sends control signals to the power generator starting circuit through the relay circuit and the PORT A is configured as analog input to receive voltage values that specify the state of particular generator parameter. The PIC is interfaced with the parameter controls of the power generator to measure or determine the state of the parameters. These parameter controls produces voltage which is reduced to a maximum of 5V with the use of transistors depending on the level

of the parameters. For example, if the generator has the fuel at full level, 5V is produced and 0V at low level. The voltage is read through the PORT A of the PIC as analog input and is interpreted to mean high or low depending on the input. PORT a status is read, the status (1 or 0) determine if the generator can be started or not (1 = YES, 0 = NO) and the status is also sent to the PC via the PIC USART for the user to know the state of the generator parameters [12]]. The PIC16F877A communicates serially with other devices that are serial communications enabled using the USART, the USART is also called the SIC (Serial Communication Interface).

Relay Circuitry

The relay circuit is responsible for performing the switching action that energizes the generator starting circuit for operation [13]. The relay circuit transforms the electrical signal from the PIC into mechanical movement that performs a switching mechanism to allow the generator to start or stop.

INTERFACING THE RMCS MODULE AND THE POWER GENERATOR

The basic starting operation as implemented by relay is shown in Figure 7.

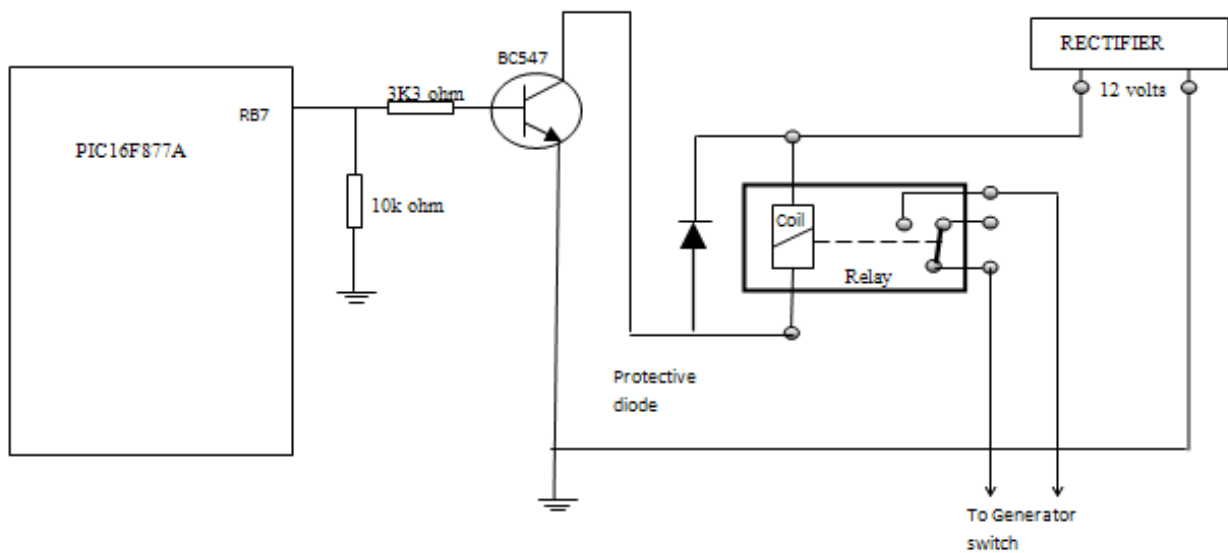

Figure 6: Connecting PIC16F877A, NPN Transistor and a Relay.

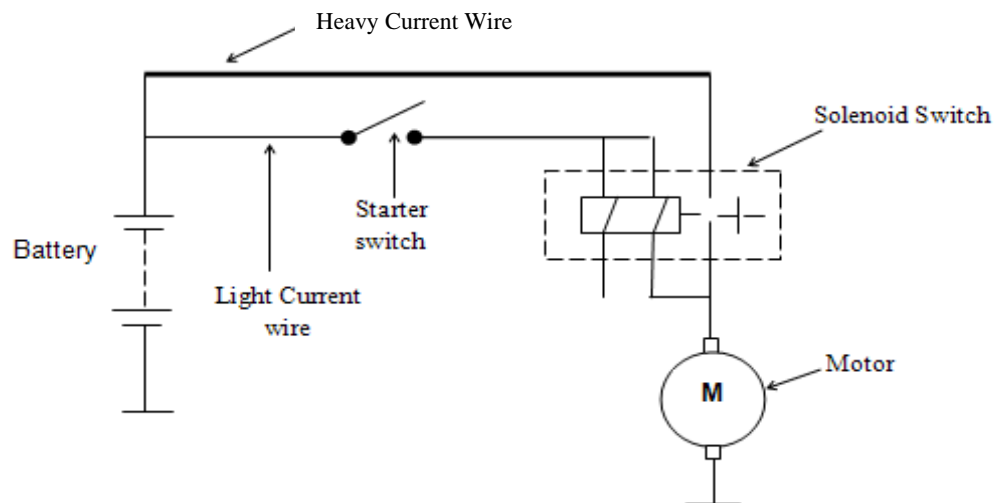

Figure 7: Basic Starting Circuitry for Power.

CONCLUSION

As stated earlier in this report, the RMCS system has two functionalities which are to control and monitor. The scope of the work focuses on the control functionality and this functionality was achieved successfully. The RMCS system was able to switch on the power generator and switch it off.

REFERENCES

1. Axelson, J. 1997. *The Microcontroller Idea Book - Circuits, Programs, & Applications featuring the 8052-BASIC Microcontroller*. Lakeview Research.
2. Hageman, S. 2008. "PIC Development on a Shoestring". <http://www.sonic.net/~shageman>.
3. So Do It Yourself. 2007. "MAX232 Serial Level Converter. (Retrieved on February 16, 2007). <http://www.sododiyourself.com>.
4. Maxim Integrated Products. 2003. "MAXIM +5V-Powered, Multichannel RS-232 Drivers/Receivers".
5. Wikipedia. 2007. "Relay". (Retrieved on February 21, 2007). <http://www.en.wikipedia.org>.
6. Eady, F. 2004. *Networking and Internetworking with Microcontroller*. Elsevier Inc.: New York, NY.
7. [7] Bradley, J.C. and A.C. Millspaugh. 2002. *Programming in Visual Basic 6.0 (Updated Edition)*. McGraw-Hill/Irwin: New York, NY.
8. Denton, T. 2004. *Automobile Electrical and Electronics Systems (Third edition)*. Elsevier Butterworth – Heinemann: New York, NY.
9. Horsely, I. 2008. "Building an ENC28J60 Ethernet Dev Board - Parts List". <http://www.piccoder.co.uk>.
10. Johnstad, K. and M. LePard. 2005. "Essential Standby Generator System Requirements for Next Generation Data Centers". (White Paper #90) American Power Conversion.
11. Code Works. 2006. "Serial Communication with VB.NET". (Retrieved on March 03, 2006). <http://www.codeworks.it/net/VBNetRs232.htm>
12. ADSL. 2006. "All Data Sheet Library". (Retrieved March 2, 2006). <http://www.alldatasheet.com>.
13. Microchip Technology, Inc. 2003. "PIC16F87XA Data Sheet". (Retrieved October 31, 2003). <http://ww1.microchip.com/downloads/en/devicedoc/39582b.pdf>

ABOUT THE AUTHORS

Mr. Ishioma A. Odigwe is a Lecturer and a Research assistant with Covenant University, Ota in the Department of Electrical and Information Engineering. He holds a Bachelors and a Masters degree in Electrical Engineering. He is a Member of the IET (formerly IEE), Member of the IEEE, and Member of the Nigerian Society of Engineers (NSE). His research interests are in renewable energy sources, power system dynamics, protection and control.

Mr. Antony U. Adoghe is a Lecturer and a Research assistant with Covenant University, Ota in the Department of Electrical and Information Engineering. He holds a Bachelors and a Masters degree in Electrical Engineering. He is a Member of the IEEE, and Member of the Nigerian Society of Engineers (NSE). His research interests are in power system reliability, protection and control.

SUGGESTED CITATION

Odigwe, I.A. and A.U. Adoghe. 2008. "Remote Monitor and Controller System for Power Generators". *Pacific Journal of Science and Technology*. 9(2):344-350.

