



Effect of Dynamic Voltage Restorer in Compensating for Voltage Sag and Controlling Harmonics in a Power Distribution System using Fumman Industry as a Case Study

Sesay S. F.

sesay_steve@yahoo.com

Adejumobi I. A.

engradejumobi@yahoo.com

Wara S. T.

docwarati@gmail.com

Mustapha A. O.

amidu_mustapha@hotmail.com

Abstract – Different power quality surveys done by researchers identify voltage sags as the most serious power quality problems for industrial customers. Voltage sag can cause serious problems to electric loads that cannot withstand variation in voltage such as adjustable speed drives, process control equipment and computers. This research work investigated the effect of Dynamic Voltage Restorer (DVR) in compensating for voltage sag and controlling harmonics in a power distribution system. A DVR is a power electronic converter base device that is used to regulate the voltage at the load terminals from various power quality problems like sag, swell unbalance etc in the supply voltage. The mathematical equations representing voltage sag and its compensation are presented. To implement the effect of DVR on industrial load network, Fumman Industry was considered as a case study. The DVR was modeled by building the subsystem of each major component. The components are injection transformer, fuzzy logic controller, battery and Pulse Width Modulation (PWM) inverter. Optimization technique was used to determine the appropriate battery size. Simulation was done without and with the DVR using Matlab/Simulink; under three and double phase line-to-ground faults. Simulation results showed that the modeled DVR can work very well against balanced and unbalanced voltage sag caused by fault in industrial distribution system considering the harmonic limits.

Keywords – Dynamic Voltage Restorer (DVR), Fumman Industry, Power Quality and Voltage Sag.

I. INTRODUCTION

Power quality is becoming an increasingly important topic in the performance of many industrial applications such as information technology, significant influence on high technology devices related to communication, advanced control, automation, precise manufacturing technique and on-line service[1]. This is because the widespread applications of power electronic based non-linear devices and faults causes deviation or distortion on the pure sinusoidal waveform produced at power station. These situations facing electricity customers and suppliers have increased the popularity and development of power quality studies. Both commercial and domestic consumers need constant sine wave shape, constant frequency and symmetrical voltage with a constant root mean square (rms) value in the electricity supply. Voltage is the main qualitative elements that condition the proper functioning of receiving electric equipment. That is why the voltage quality practically

defines the power quality. To satisfy these demands, the disturbances must be eliminated from the system. The typical power quality disturbances are voltage sags, voltage swells, interruptions, phase shifts, harmonics and transients [2]. Voltage sag is always considered as one of the major power quality problems because the frequency of occasion is so high [3]. Moreover, according to the data recorded by Fumman industry voltage sags have been experienced frequently and have caused serious production process interruption which has resulted in great financial losses.

There are various types of voltage sag mitigation equipment that are available nowadays such as Uninterrupted Power Supply (UPS), flywheel, and the flexible ac technology (FACTS) devices which have been widely used in power system due to the reliability to maintain power quality control [4]. The DVR has been recognized to be the best effective solution to overcome power quality problem; compared to the other devices, the DVR clearly provides the best economic solution for its size and capability [5]. The DVR however is a power electronic device. It can generate harmonics. This harmonics must be within the permissible limits of 5% [6].

II. DEFINITION OF TERMS

A. Voltage Sag

According to IEEE standard 1100-1992, sag (or dip) is an rms reduction in the ac voltage at the power frequency for durations from half a cycle to a few seconds [6]. It is assumed that the rms values between 90% and 110% of nominal voltage cannot disturb the circuit operation [7]. Voltage sag event occurs when the rms value of nominal voltage drops below the threshold voltage (typical value is 90%). Magnitude and duration are two essential and important sag characteristics that determine the equipment behavior [8].

- 1) Sag magnitude: It is the net rms voltage reduction during the fault, in percent or in per unit (pu) system nominal (rated) voltage.
- 2) Sag duration: Sag duration is the time the voltage is low, usually less than 1 second. For instance, the voltage sag profile shown in Fig. 1 has a magnitude of 50% and duration of 0.2 second.

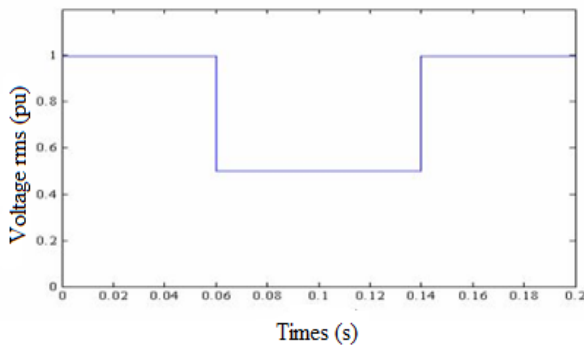

Fig.1. Voltage sag to 50% at rms voltage

B. Fumman Industry

Fumman Industry is located in Apata, Ibadan, Nigeria. It has been reported that voltage sags have been experienced in the industry and have caused serious production process interruption which has resulted in great financial losses. Fumman Industry has the sole aim of processing and marketing wholesome fruits and juice in Nigeria. Within its production process very sensitive processing equipment is utilized called Tetra-Paks. Fumman Industry has an installed capacity of 1.5 MVA. It is fed from 33 kV feeders from Ayede substation. The 33 KV is step down to 415V by a 33 MVA power transformer and power is distributed within the facility in the medium voltage range of 415 V.

III. METHODOLOGY

A fuzzy logic controlled based DVR is modeled with the power system of Fumman industry and then the modeled power system under study is simulated without and with DVR under fault conditions.

A. Mathematical Model for Voltage Sag Calculation in Fumman Industry

Consider Fig. 2 as Fumman industry that consist of two feeder; under normal condition (no fault), current flow to the machines that can withstand voltage variation through feeder 1 and to the Tetra-Paks machines that cannot withstand voltage variation through feeder 2. When there's fault on feeder 1, a high current (short circuit current) will flow to feeder 1. So, based on Kirchhoff's Law, currents flow to feeder 2 will be reduced. Consequently, voltage will also drop in feeder 2. This voltage drop is defined as voltage sag.

Assuming the impedance of feeder 1 machines = Z_A and the impedance of feeder 2 machines = Z_B , source reactance = X_s , Feeder 1 Reactance = X_1 , Feeder 2 Reactance = X_2 , current from supply source = I , Current in feeder 1 = I_1 , current in feeder 2 = I_2 , from Fig. 2, by using Kirchhoff's Current Law,

$$I = I_1 + I_2 \quad (1)$$

In normal condition that is without fault in the industry

$$I = \frac{V_2}{X_1 + Z_A} + \frac{V_2}{X_2 + Z_B} \quad (2)$$

$$V = I \left(\frac{1}{X_1 + Z_A} + \frac{1}{X_2 + Z_B} \right) \quad (3)$$

When a fault occurs in feeder 1 as shown in Fig. 2, because of short circuit, a high current will flow through feeder 1 as well as source current I [9]. During this time, voltage in feeder 2 is decreased due to increasing of voltage drop across source reactance X_s , this causes voltage sag.

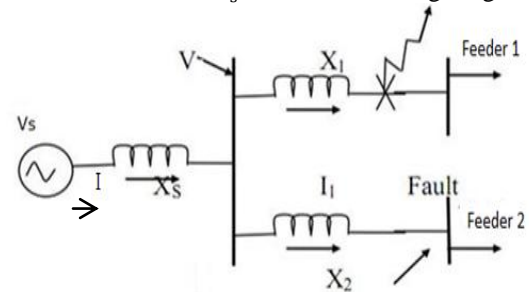

Fig.2. Voltage sag calculation

$$I = \frac{V}{X_1} + \frac{V}{X_2 + Z_B} \quad (4)$$

$$V = V_s - IX_s \quad (5)$$

V_s = voltage from Ayede Substation

During the fault condition, voltage drop (IX_s) increases and hence from equation 5, V decreases from its nominal value (i.e. V is then known as voltage sag).

B. Mathematical Model for Voltage Sag Compensation in Fumman Industry by DVR

Let Fig. 3 represents the schematic diagram of the DVR connected in Fumman industry. The circuit left hand side of the DVR represents the Thevenin equivalent circuit of the system [10]. The system impedance ($Z_{th} = R_{th} + jX_{th}$) depends on the fault level of the load bus.

Consider Fig. 2 to be Fumman industry under a normal condition (no fault), current through feeder 1 machine and through feeder 2 machines is equal to the system voltage (V) drops, the DVR injects a series voltage V_{DVR} through the injection transformer so that the desired voltage of the machines V_L can be maintained.

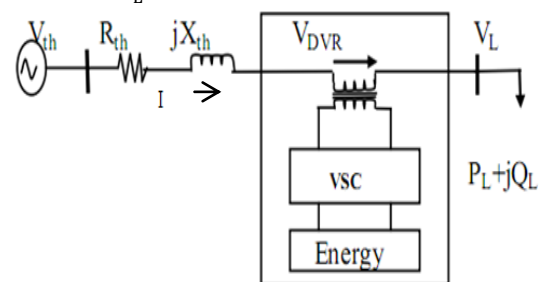

Fig.3. Schematic diagram of Fumman industry DVR

Consider the schematic diagram shown in the above Fig 3. By using KVL

$$V_{th} - Z_{th} I_L + V_{DVR} = V_L \quad (6)$$

$$V_{DVR} + V_{th} = V_L + Z_{th} I_L \quad (7)$$

Therefore, the series injected voltage of the DVR can be written as

$$V_{DVR} = V_L + Z_{th} I_L - V_{th} \quad (8)$$

Where,

V_{th} = system supply voltage (Thevenin voltage)

$$V_L = \text{Fumman industry machine feeder voltage}$$

$$Z_{th} = \text{Fumman power system impedance (Thevenin impedance)}$$

$$I_L = \text{Tetra-Paks machines current}$$

$$I_L = \left[\frac{P_L + jQ_L}{V_L} \right]^* \quad (9)$$

When V_L is considered as a reference, equation 8 can be rewritten

$$V_{DVR} < 0 = V_L < 0 + Z_{TH} < (\beta - \theta) - V_{TH} < \delta \quad (10)$$

α, β, δ are angles of V_{DVR}, Z_{TH}, V_{TH} respectively and θ is load power angle. Then the compensated load voltage will then be

$$V = (V_s - IX_s) + V_{DVR} \quad (11)$$

C. Simulink Model of the Power System under Study

A fuzzy logic based control DVR is built in Matlab/Simulink and installed into Fumman industry power system to protect two sensitive machines called Tetra-Paks 1 and 2. The DVR system under study is modeled by building the main individual components of the DVR in Matlab/Simulink environment. The power system under study is shown in Fig. 4.

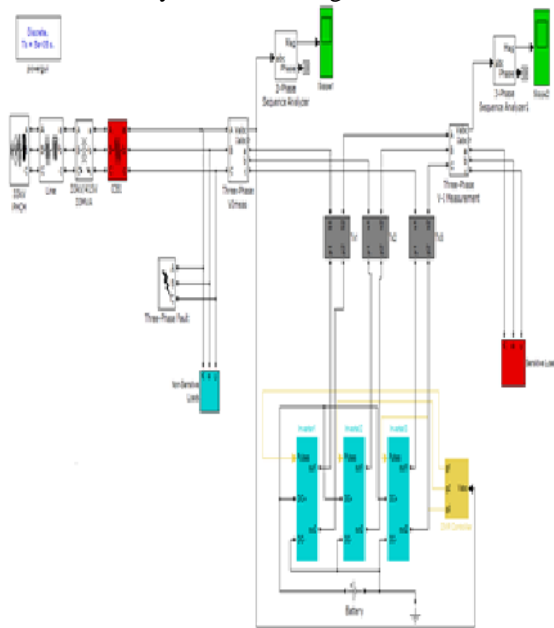

Fig.4. Power system under study

1) Voltage Source Pulse Width Modulation (PWM) Inverter

A single phase full wave inverter bridge is used in the design. It is built using 4 IGBT switches (S1, S2, S3, S4) and 4 anti-parallel diodes (D1, D2, D3, D4). The configuration is the same for the other two phases. The IGBT switch and diode are represented in the model as an ideal switch and diode respectively. The model of the single-phase PWM inverter is shown in Fig.5.

2) Injection Transformer

Three 250KVA single-phase transformers are used. The injection transformers connect the DVR to the distribution network via the high voltage windings.

3) Fuzzy Logic Controller

The fuzzy logic controller does not require a mathematical model of the system process being controlled. However, an understanding of the system process and the control requirements is necessary [11]. The block diagram of a single phase fuzzy logic controller is shown in Fig. 6

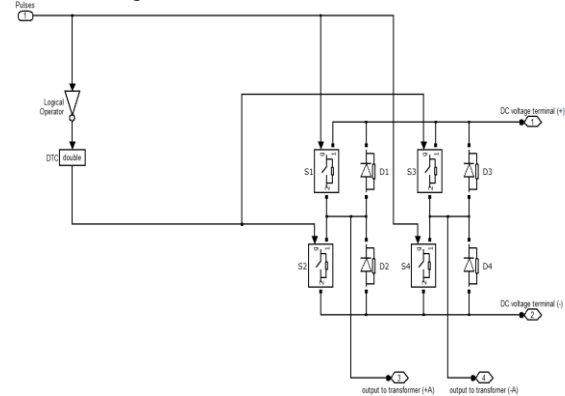

Fig.5. Single-Phase PWM inverter

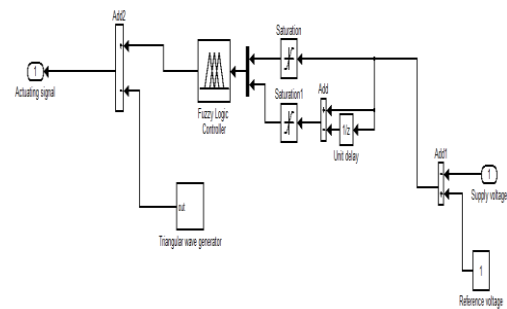

Fig.6. Block diagram of a single phase fuzzy logic controller

Table I gives the summary of the DVR parameters used in the simulation.

Table I: DVR Parameters

DVR	
Rated Capacity	750 KVA
Maximum Injection Capacity- three phase	≤ 75%
Maximum Voltage Injection (Single phase)	180V
Injection Transformer	
Rated Capacity	250 KVA
Nominal Power	3 x 250KVA
Primary Winding Voltage	100V
Secondary Winding Voltage	180V
Inverter	
Inverter Capacity	3 x 250 KVA
Semiconductor Voltage	140, 0.4 V
DC Battery	
Voltage(dc)	430V
Data of Semi-conductor Devices	
Ideal switch voltage (peak)	140
Diode Voltage (peak)	140
Forward Voltage	0.4

4) Fumman Industry Loads

Fumman Industry facility has an installed capacity of 1.5 MVA. It is fed from 33 kV feeders from Ayede

substation as shown in Fig. 7. The 33 KV is step down to 415V by a 33 MVA power transformer. Within the facility there are two synchronous generators installed, each of which has a capacity of 500 KVA. When there is no power supply from Power Holding Company of Nigeria (PHCN) the synchronous generators are used to power the facilities. Power is distributed within the facility in the medium voltage range of 415V.

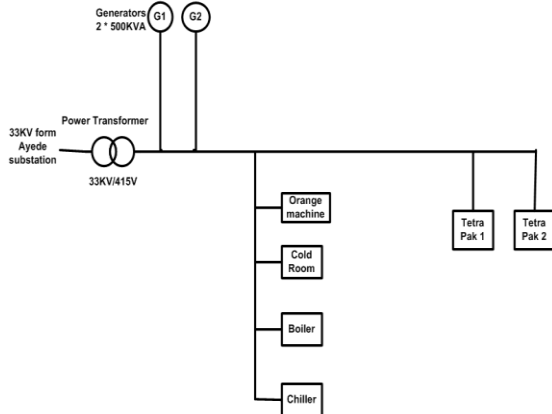

Fig.7. The block diagram of Fumman industry

The Fumman industry loads are represented by three-phase parallel RL loads in the model. Table II shows the active, apparent and reactive power of the loads in Fumman industry.

Table II: Load Calculation Table

Loads	Active power (P) Kw	Apparent Power (S) Kw	Reactive power (Q) Kvar
Orange Line	100.00	125.00	60.00
Cold Room	130.00	162.50	97.50
Boiler	60.00	75.00	45.00
Chiller	210.00	262.50	157.50
Tetra - Pak 1	500.00	625.00	375.00
Tetra - Pak 2	500.00	625.00	375.00

IV. SIMULATION RESULT

In order to show the compensating ability of the modeled DVR; the system under study is simulated without and with DVR for three and two phaseline –to-ground faults.

A. Three Phase Line – to - Ground Fault

When a three phase line-to-ground fault was introduced into Fumman industry power system, voltage sag was observed in the voltage profile. The voltage profile for the case of the Fumman industry without a DVR and with DVR is shown in Fig. 8 and Fig. 9 and they are described by equation 5 and equation 11 respectively.

B. Double phase Line – to - Ground Fault

For the case of a double phase line-to-ground fault, the Fumman industry power system experienced an unbalanced voltage sag on the voltage profile. The Fumman industry voltage profile without DVR and with DVR is thus presented in Fig. 10 and Fig. 11. The voltage profiles are described by equation 5 and 11 respectively.

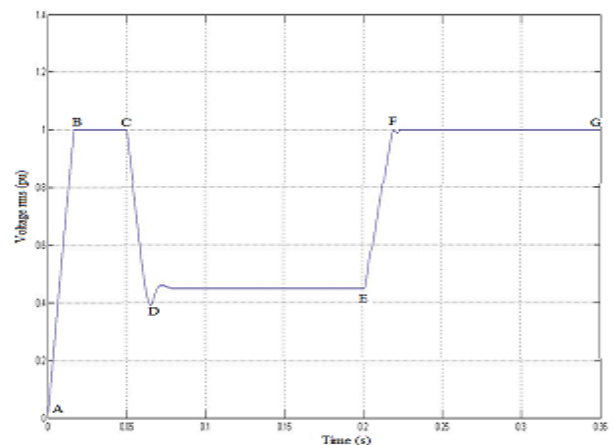

Fig.8. Load voltage without DVR for three phase line-to-ground fault

AB: Transient response
 BC: Nominal voltage
 DE: Sag voltage level

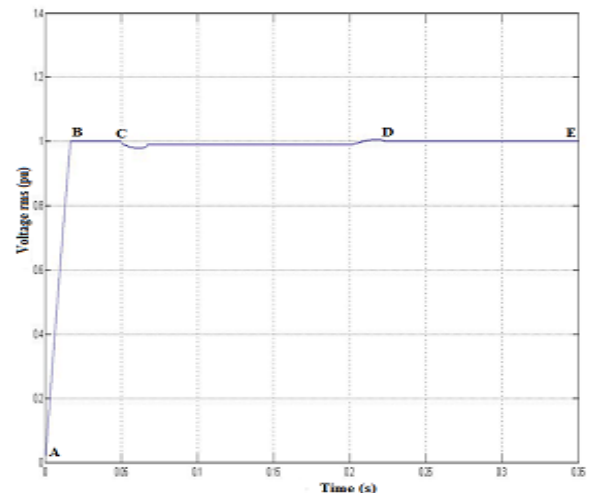

Fig.9. Load voltage with DVR for three phase line-to-ground fault

AB: Transient response
 BC: Nominal Voltage
 CD: Compensated voltage level

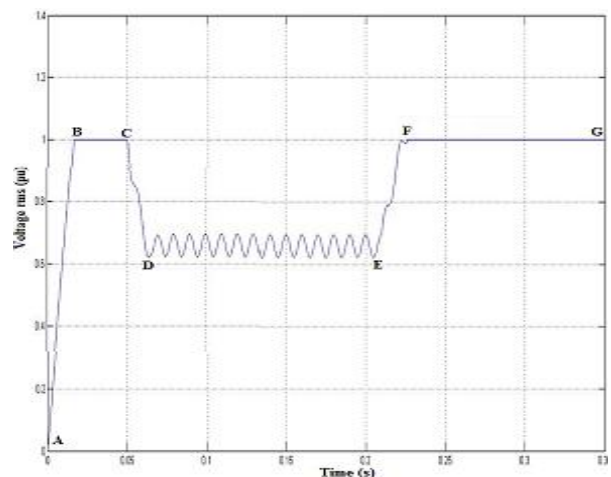

Fig.10. Load voltage without DVR for double phase line-to-ground fault

AB: Transient response
BC: Nominal voltage
DE: Minimum sag voltage level

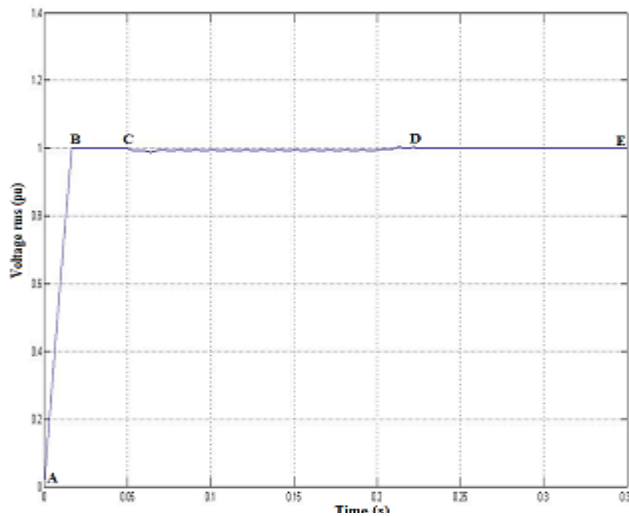

Fig.11. Load voltage with DVR for double phase line-to-ground fault

AB: Transient response
BC: Nominal voltage
CD: Compensated voltage level

The compensating ability of a DVR working against voltage sag in a certain power system hinged on two main factors: the sag level and the THD introduce. Both of these in turn are decided by the DC battery voltage [13]. Thus in this simulation studies the effect of the electrical energy level on the performance of the DVR is investigated. The Tetra-Paks machines that are to be protected consist of motors and ac drives. The threshold voltage for motors and ac drives against voltage sag are 50% and 75% respectively [7][13]. The ac drives has the highest threshold voltage to operate correctly for most industrial machines and equipment. Thus three phase line -to-ground fault with 50% and 75% sag level are created.

Table III: Effect of DVR Battery DC Voltage on Fumman Industry Voltage Sag and THD at 50% RMS Voltage Sag.

DVR Battery DC Voltage (V)	Fumman Industry Voltage Sag(%)	THD (%)	IEEE Sag Threshold (%)	IEEE THD Threshold (%)
0	50	0	10	5
100	34	4	10	5
200	18	2.5	10	5
300	10	3	10	5
400	5	2	10	5
500	3	4	10	5
600	2	5	10	5

First, a constant value of DC battery voltage is set and the changes in THD and Fumman Industry load (rms) voltage due to voltage sag level changes is recorded. Then, it is repeated for a number of other DC voltage values. The results simulated are summarized in Tables III and IV. The last two columns in each Table present the derived thresholds that voltage sag and THD must meet [12].

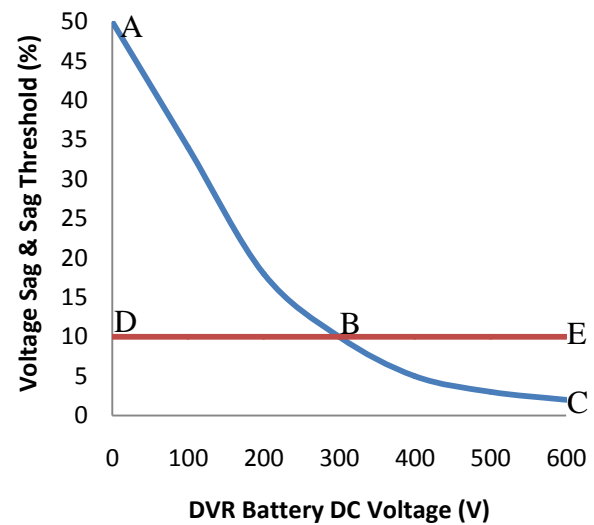

Fig.12. Effect of DVR battery DC voltage on Fumman voltage sag at 50% rms voltage sag

AC: Voltage sag curve
AB: Voltage sag above IEEE threshold limit
BC: Voltage sag below IEEE threshold limit
DE: IEEE voltage sag threshold curve

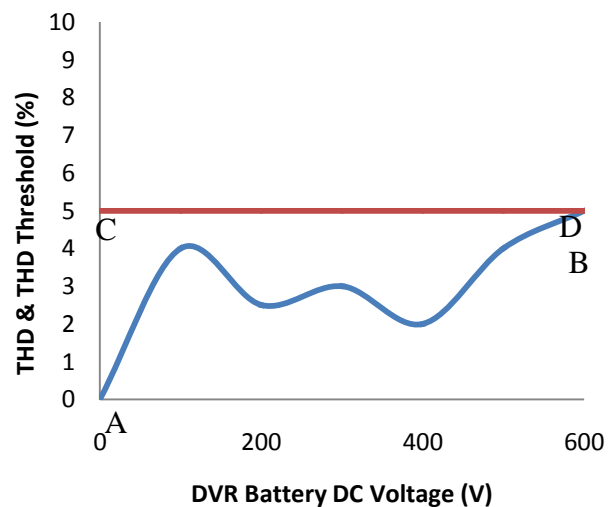

Fig.13: Effect of DVR battery DC voltage on Fumman THD at 50% rms voltage sag

AB: Fumman industry THD curve
CD: IEEE THD threshold curve

Table IV: Effect of DVR Battery DC Voltage on Fumman Industry Voltage Sag and THD at 75% RMS Voltage sag

DVR Battery DC Voltage (V)	Fumman Industry Voltage Sag(%)	THD (%)	IEEE Sag Threshold (%)	IEEE THD Threshold (%)
0	75	0	10	5
100	55	8	10	5
200	35	7	10	5
300	23	8	10	5
400	12	4	10	5
500	6.5	4	10	5
600	2.5	5.5	10	5

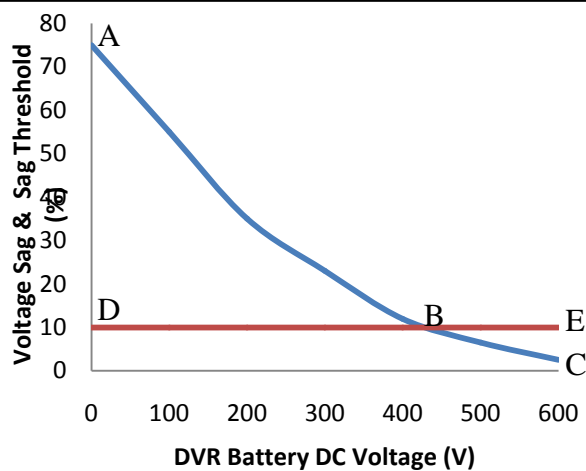

Fig. 14. Effect of DVR battery DC voltage on Fumman voltage sag at 75% rms voltage Sag

- AC: Sag curve
AB: Voltage sag above IEEE threshold limit
BC: Voltage sag below IEEE threshold limit
DE: IEEE voltage sag threshold curve

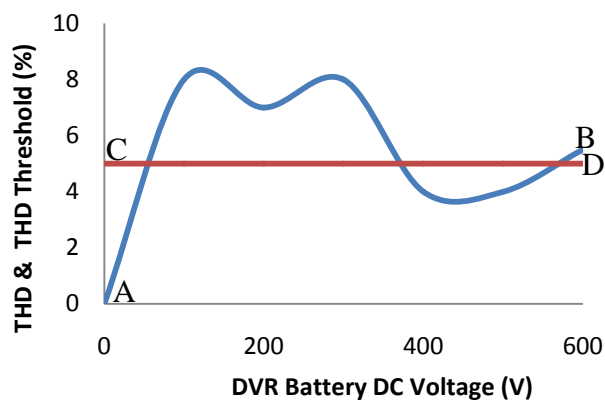

Fig. 15: Effect of DVR battery DC voltage on Fumman industry THD at 75% rms voltage

- AB: THD curve
CD: IEEE THD threshold curve

V. DISCUSSION

The modeled DVR was connected in series with the two feedersloads. The performance of the DVR was then evaluated under fault conditions. Two types of fault were introduced into the system, a three phase line-to-ground fault and a double phase line-to-ground fault. When these faults were introduced, a sag in the voltage profile was observed for the duration of the fault period.

For the case of the three phase line-to-ground fault, when a fault of resistance 0.001Ω and ground resistance of 0.00001Ω lasting from 0.005s to 0.2s was applied to the power system as shown in Fig. 12, a voltage sag (equation 5) up to the tune of 53% of rms voltage was observed and in Fig. 13 when the DVR was connected (equation 11), the Fumman industry rms voltage sag was compensated by 52.8%.

For the case of the double phase line-to-ground fault, when a fault of resistance 0.001Ω and ground resistance of 0.00001Ω lasting from 0.005s to 0.2s was applied to the power system as shown in Fig. 14, voltage sag (equation 5) to the tune of 39.0% of rms voltage was observed and in Fig. 15 when the DVR was connected, the Fumman industry rms voltage sag was compensated (equation 11) by 38.9%.

Inorder to study the effect of electrical energy level on the performance of the DVR; the result of Table III are illustrated in Fig. 12 and Fig. 13 while the results of Table IV are illustrated in Fig. 14 and Fig.15

Fig.12 illustrates the relationship between DVR battery DC voltage (V) and Fumman industry voltage sag (%) for a 50% rms voltage. Curve AC in Fig. 12represents the Fumman industry voltage sag curve while curve DE represents the IEEE voltage sag threshold curve. It is observed that the curve AB portion of the AC curve is above the IEEE threshold limit for permissible voltage sag in power systems but the BC portion of curve AC is within the IEEE permissible voltage sag level [6]. Thus, we can now deduce the appropriate value of DVR battery DC voltage that will be suitable for the optimised operation of the DVR within acceptable standards for 50% rms voltage sag. Therefore for 50% rms voltage sag, a DC voltage battery of a minimum of 300 Vcapacity is required for the optimized performance of the DVR.

Fig.13 illustrates the relationship between DVR battery DC voltage and Fumman industry THD for a 50% rms voltage. Curve AB in Fig.13represents the Fumman industry THD curve with DVR while curve CD represents the IEEE THD threshold curve. It is observed that the curve AB lies wholly within the IEEE threshold limit for permissible THD of 5% in power systems [6].

Fig.14 illustrates the relationship between DVR battery DC voltage (V) and Fumman industry voltage sag for a 75% rms voltage sag. Curve AC in Fig. 14 represents the Fumman industry voltage sag curve with DVR while curve DE represents the IEEE voltage sag threshold curve. It is observed that the curve AB portion of the AC curve is above the IEEE threshold limit for permissible voltage sag in power systems but the BC portion of curve AC is within the IEEE permissible voltage sag level [6]. Thus, we can now deduce the appropriate value of DVR DC battery voltage that will be suitable for the optimised operation of the DVR within acceptable standards for 75% rms voltage sag. Therefore for 75% rms voltage sag, a DC voltage battery of a minimum of 430Vcapacity is required for the optimized performance of the DVR.

Fig. 15 illustrates the relationship between DVR battery DC voltage (V) and Fummanindustry THD for 75% rms voltage sag. Curve AB in Fig. 15 represents the Fumman industry THD curve with DVR while curve CD represents the IEEE THD threshold curve. It is observed that only Portion DE lies wholly within the IEEE threshold limit for permissible THDin power systems [6].

VI. CONCLUSION

Voltage sag can cause many crucial production processes to face huge economic loss. The DVR provides the best economic solution for its size and capability. The harmonics generated by the DVR must be within permissible limits. This work investigated the effect of DVR in compensating for voltage sag and controlling harmonics in a power distribution system. The study was mainly involved with changes in the values of the DC battery voltage rating. The results of this study revealed that the ability of the DVR to efficiently compensate voltage sag depends mainly on the DVR DC battery voltage and sag level. The DVR battery capacity was observed to have a significant effect on the level of voltage sag compensation with an inverse relationship. The voltage sag reduced as the battery capacity was being increased and that increasing DC voltage rating does not result in a dramatic increase of the THD.

REFERENCES

- [1] M.H.J. Bollen. "Voltage Sags in Three Phase Systems". *IEEE Power Engineering Review*, 21(9):8-11, 2001.
- [2] M.D. Stump, G.J. Keane, and F.K.S. Leong, The Role of Custom Power Products in Enhancing Power Quality at Industrial Facilities. *IEEE Energy Management and Power Delivery*, 2: 507-517, 2000.
- [3] R.H. Salimin, and M.S.A. Rahim, Simulation Analysis of DVR performance on voltage sag mitigation: *The 5th international power Engineering and optimisation conference (PEOCO2011), Shah Alam, Selangor, Malaysia. PP 261-266. 2011.*
- [4] A Gole, and L. Palav, Modeling of Custom Power Devices in PSCAD/EMTDC. *Centre Journal*, 11, 1998
- [5] A O Al-Mathnani, S Hussain, M Azah, M.A. Hannan, Power Quality Improvement Using DVR with Two Fast Vector Control: *The 4th International Power Engineering and Optimization Conf. (PEOCO290), Shah Alam, Selangor Malaysia: June 2010.*
- [6] IEEE standard board. IEEE Std 1159-1992. *1992 IEEE Recommended Practice for Monitoring Electric Power Quality*. The Institute of Electrical and Electronics Engineers, Inc., pp 11-23
- [7] D.J. Won, S.J. Ahn, I.Y. Chung, J.M. Kim, and S.I. Moon, A New Definition of Voltage Sag Duration Considering the Voltage Tolerance Curve: *IEEE Power Tech Conference Proceedings*, 3: 1-5.
- [8] C Radhakrishna, M Eshwardas, and G Chebiyam, Impact of Voltage Sags in Practical Power System Networks: *IEEE Transmission and Distribution Conference and Exposition*, 1: 567-572.
- [9] S.W. Wahab, and A.M. Yosof, Voltage Sag and Mitigation Using Dynamic Voltage Restorer (DVR) System", *elektrika*, vol.8, No.2, pp. 32-37, 2006.
- [10] B. Rajani and P.S. Raju, Performance Analysis of Dynamic Voltage Restorer (DVR) using Sinusoidal and Space vector PWM Techniques. *International Journal of Engineering Research & Technology (IJERT) Vol. 1 Issue 3, May – 2012.*
- [11] P Chawla, R Khanna, and A. Singh, Fuzzy Logic Control for DVR to counter voltage sag on Distribution Network: *Proceedings of the world congress on Engineering 2011 vol 11, INCE, July 6-8, 2011, London, U.K.*
- [12] IEEE standard board. IEEE Std 1159-1995. *1995 IEEE Recommended Practice for Monitoring Electric Power Quality* (The Institute of Electrical and Electronics Engineers, Inc., Page(s): 11-23.)
- [13] I.Y. Chung, D.J. Won, Park S.Y., Moon S.I., and Park J.K. The DCLink Energy Control Method in Dynamic Voltage Restorer System. *Electrical Power and Energy Systems*, 25: 525–531, 2003

AUTHOR'S PROFILE



Sesay, Steven Foday

obtained his B. Eng (Hons) degree in Electrical and Electronics Engineering from Fourah Bay College, University of Sierra Leone, Sierra Leone in 2010. He is presently on Scholarship at Federal University of Agriculture, Abeokuta where he is working towards M.Eng. degree in Electrical Machines and Power Systems. His research interests include power systems, power electronics, power quality and renewable energy.



Dr. Adejumobi, Isaiah Adedijire

received his Ph.D in Electrical and Electronics Engineering from Ilorin University. He was formerly the Head of Electrical and Electronics Engineering Department, Federal University of Agriculture, Abeokuta. He is a registered member of the Council for Regulation of Engineering in Nigeria (COREN), and also a Corporate Member of Nigerian Society of Engineers (MNSE) as well as member, International Researchers of Sustainable Energy Sources: Small Hydro Power. He takes keen interest in Engineering research, design and supervision with more interest in Electric Power Systems.



Prof. Wara, Samuel Tita

obtained his B.Eng, M.Eng and Ph.D in Electrical and Electronics Engineering from the University of Benin, Nigeria in 1990, 1991 and 1995. Currently he is the Head of Electrical and Electronics Engineering Department. His research interests include power system, Electric machines, Energy efficiencies, Energy management and renewable energy.



Dr. Mustapha, Amidu Olalekan

received the B.Sc. and M.Sc. degrees from Ahmadu Bello University, Zaria, Nigeria and Ph.D, degree in 1999 from University of Nairobi, Kenya. His research interests include radiation transport and interaction, measurements and applications of radiation, radiation protection and radioecology.