

**Impact of learner control on learning in adaptable and  
personalised e-learning environments**

Dissertation for the Award of the Academic Degree  
Doctor of Philosophy  
in the School of Computing and Mathematical Sciences  
of the University of Greenwich  
London, UK

February 2011

**By: Alan Mustafa**

**Supervised by: Dr. Liz Bacon**

**Prof. Mohammad Dastbaz**

**Dr. Ray Stoneham**

## DECLARATION

I certify that this work has not been accepted in substance for any degree, and is not concurrently submitted for any degree other than that of Doctor of Philosophy (PhD) of the University of Greenwich. I also declare that this work is the result of my own investigation except where otherwise identified by references and that I have not plagiarised the work of others.

Alan Mustafa  \_\_\_\_\_

Date: 13/6/11

(Student)

Dr Liz Bacon \_\_\_\_\_

Date: 14/6/11

(Supervisor)

## **Dedication**

*I dedicate this thesis to my father, whom's memories will be with me forever,*

*proudly;*

*To my mother who believed in me and I know that her sacrifices can't be replaced*

*with anything in the world;*

*My brother (Kawa) and sister (Rezan) and two children (Khoshin and Olzan) whom*

*have been patient with me throughout my study;*

*Shirin (my wife) whom gave me a new life and purpose to live for;*

*All friends and family member's whom have been concerned about and supportive*

*throughout my research.*

*Alan Mustafa*

*(Alan Hamid Sori)*

*14/12/2010*

## **Acknowledgements**

I would like to take this opportunity to show my gratitude to all the people who supported and helped me during the course of this project. I would like to thank Prof. Mohammad Dastbaz and Dr. Ray Stoneham who have initiated, helped and supervised the project. I would like to thank Dr. Liz Bacon whom I am most grateful on supervising my project, believed in my research and the continuation of it. I specifically want to show my profound appreciation to Prof. Lachlan Mackinnon whom guided the research with clearer direction.

I am also thankful to members of Information Technology support team for providing technical support to the project, and all members of staff in the school whom have been patient with me for the past may years.

## **Abstract**

The purpose of this thesis is to investigate the impact of learners' measure of control over their learning, while working in different online learning environments, and how this, in combination with a structured learning material selection according to their learning preferences, can affect their learning performance.

A qualitative study was carried out on the understanding of different learning philosophies, different learning environments and different learning preferences, in correlation with learners' measure of control over their learning environments, in terms of their influence on their learning performance.

The research commenced with a survey of UK Higher Educational institutions, to determine the usage of adaptive e-learning systems in UK HE and the type and nature of the systems in use, which in combination with the literature review enabled the clarification of the research hypothesis and objectives. Since a measurement of learners' learning performance was needed, an adaptable personalised e-learning system (A<sub>L</sub>PELS) was developed to create an environment where a qualitative measurement could be done. Experimental data was then gathered from two cohorts of MSc students over two semesters, who used the newly designed and developed online learning environment.

The successful implementation of the project has produced a large amount of data, which demonstrates a correlation between i) adaptable and personalised e-learning systems, and ii) learners' learning styles (which in itself supports the behaviouristic approach towards this type of online learning environment – A<sub>L</sub>PELS).

The study indicates a dependency between an online controlled learning environment and learners' learning performances, showing that a personalised e-learning system

(PELS) would be supportive of recall (R) and understanding (U) types of content materials (with an indication of 4.89%), but also demonstrating an increase in student learning performance in an adaptable e-learning system (A<sub>L</sub>ELS) while using competency (C) types of content materials (with an indication of 5.43%). These outcomes provide a basis for future design of e-learning systems, utilising different models of learner control based on underpinning educational philosophies, in combination with learning preferences, to structure and present learning content according to type.

## Table of Contents

|   |             |
|---|-------------|
| <b>ABBREVIATIONS</b> .....  | <b>XIII</b> |
| <b>KEY TERMS</b> .....  | <b>XIV</b>  |
| <b>CHAPTER 1 INTRODUCTION</b> .....   | <b>1</b>    |
| 1.1 OVERVIEW.....   | 1           |
| 1.2 BACKGROUND TO THE STUDY.....  | 1           |
| 1.3 HYPOTHESIS .....  | 3           |
| 1.4 AIMS AND OBJECTIVES OF THIS RESEARCH.....   | 3           |
| 1.5 METHODOLOGY.....  | 4           |
| 1.6 CHAPTERS OF THE THESIS.....   | 5           |
| <b>CHAPTER 2 LITERATURE REVIEW</b> .....  | <b>8</b>    |
| 2.1 OVERVIEW.....   | 8           |
| 2.2 BACKGROUND TO LEARNING AND E-LEARNING SYSTEMS.....  | 8           |
| 2.2.1 <i>Learning Processes and Need for Learning and Teaching Philosophies</i> .....                       | 11          |
| 2.2.2 <i>Methods of Instructional Design</i> .....  | 13          |
| 2.2.3 <i>Child-, adult-, learner- and teacher-centred learning environments</i> .....                       | 18          |
| 2.2.4 <i>E-Learning Systems</i> .....   | 22          |
| 2.2.5 <i>Advantages and Disadvantages of Online Learning</i> .....  | 28          |
| 2.2.6 <i>Conclusion of this section</i> .....   | 29          |
| 2.3 ADAPTIVITY OF LEARNING AND E-LEARNING SYSTEMS.....  | 30          |
| 2.3.1 <i>Adaptive Systems Processes</i> .....   | 30          |
| 2.3.2 <i>Differences between adaptable and adaptive systems</i> .....                                       | 33          |
| 2.4 KNOWLEDGE MANAGEMENT AND PERSONALISATION OF E-LEARNING SYSTEMS .....                                    | 34          |
| 2.5 INDIVIDUAL'S LEARNING FACTORS .....   | 37          |
| 2.5.1 <i>Learner-centred psychological principles</i> .....   | 37          |
| 2.5.2 <i>Learning Preferences</i> .....   | 41          |
| 2.5.3 <i>Current traditional learning methodologies in relation to the duration of learning</i><br>42       |             |
| 2.5.4 <i>Conclusion on Individuals' Learning Factors</i> .....  | 44          |
| 2.6 ISSUES IN DESIGNING AN ADAPTIVE E-LEARNING SYSTEM.....  | 44          |
| 2.6.1 <i>Issues in Designing a Learning System</i> .....  | 45          |
| 2.6.2 <i>Preliminary analysis of designing an adaptive e-learning system</i> .....                          | 46          |
| 2.7 CONCLUSION OF THIS CHAPTER .....  | 49          |
| 2.8 REFINING THE HYPOTHESIS AND METHODOLOGY BASED ON NEW FINDINGS .....                                     | 51          |
| <b>CHAPTER 3 ISSUES IN DESIGNING AN ADAPTABLE, ADAPTIVE AND/OR<br/>PERSONALISED E-LEARNING SYSTEM</b> ..... | <b>52</b>   |
| 3.1 OVERVIEW.....   | 52          |
| 3.2 A REVIEW AND ANALYSIS OF TRADITIONAL AND CURRENT E-LEARNING MODELS.....                                 | 53          |
| 3.3 PHYSIOLOGICAL LEARNING CATEGORY .....   | 57          |
| 3.4 CONTROL SYSTEMS .....   | 60          |
| 3.4.1 <i>Closed-loop Control system</i> .....   | 60          |
| 3.5 CONCLUSION OF THIS CHAPTER .....  | 62          |
| <b>CHAPTER 4 DESIGNING AN ADAPTABLE, ADAPTIVE AND/OR PERSONALISED<br/>E-LEARNING SYSTEM</b> .....           | <b>64</b>   |
| 4.1 OVERVIEW.....   | 64          |
| 4.2 INTRODUCTION.....   | 64          |
| 4.3 OVERVIEW OF THE E-LEARNING SYSTEMS DEVELOPED .....  | 65          |
| 4.4 PHYSIOLOGICAL LEARNING CATEGORY .....   | 68          |

|  |  |            |
|--|--|------------|
| 4.5  | CONTENT OBJECT PROVIDER SYSTEM AND DECISION MAKER UNIT – FROM CONCEPT TO DESIGN .....  | 69         |
| 4.6  | A HIGH-LEVEL OVERVIEW OF A LEARNING OBJECT CREATOR FOR A PERSONALISED ELS .....  | 72         |
| 4.7  | ANALYSIS AND DESIGN OF THE DECISION MAKER UNIT (DMU).....  | 73         |
| 4.7.1  | <i>Analysis of the Decision Maker Unit (DMU)</i> .....   | 74         |
| 4.7.2  | <i>Proposing a Design for the Process of the Decision Making Unit in an A<sub>V</sub>,A<sub>L</sub>,P,ELS</i> .....  | 76         |
| 4.8  | PROPOSED FORMS OF E-LEARNING SYSTEMS UNDER STUDY .....   | 78         |
| 4.8.1  | <i>A<sub>L</sub>PELS (Adaptable Personalised E-Learning System)</i> .....  | 85         |
| 4.9  | A FRAMEWORK FOR DESIGNING ASSESSMENT QUESTIONS .....   | 87         |
| 4.10   | CONCLUDING REMARKS.....  | 88         |
| <b>CHAPTER 5 EXPERIMENTAL DESIGN FOR A<sub>L</sub>PELS (DESIGN, DEVELOPMENT AND IMPLEMENTATION OF A<sub>L</sub>PELS) .....</b> |  | <b>89</b>  |
| 5.1  | OVERVIEW.....  | 89         |
| 5.2  | INTRODUCTION.....  | 89         |
| 5.3  | MAJOR ASPECTS OF THE DESIGN PHASE OF A <sub>L</sub> PELS .....   | 90         |
| 5.4  | ARK-BASED SWITCHBOARD, WHAT IT IS AND HOW IT WORKS .....   | 104        |
| 5.4.1  | <i>What is an ARK-based Switchboard and its relevancy to this research?</i> .....  | 104        |
| 5.4.2  | <i>Learning objects and ARK-based content material</i> .....   | 121        |
| 5.5  | DESIGNING ASSESSMENT MATERIALS FOR MEASURING LEARNERS' LEARNING PERFORMANCE  | 124        |
| 5.6  | IMPLEMENTATION OF ADAPTABLE AND PERSONALISED ELS.....  | 126        |
| 5.7  | CONCLUSION.....  | 128        |
| <b>CHAPTER 6 EXPERIMENTAL DESIGN AND DATA EVALUATION .....</b>   |  | <b>129</b> |
| 6.1  | OVERVIEW.....  | 129        |
| 6.2  | DATA COLLECTION AND METHODOLOGY OF DATA ANALYSIS .....   | 129        |
| 6.3  | DATA ANALYSIS AND FINDING – CATEGORISATION OF LEARNERS OUTCOME BASED ON THE DURATION OF THEIR ACTIVITIES.....  | 130        |
| 6.3.1  | <i>Data Analysis and Findings on Learners' Performance based on their learning preferences and VARK- &amp; ARK-based content materials</i> .....                 | 130        |
| 6.3.1.1  | Methodology used on data analysis .....  | 130        |
| 6.3.1.2  | Results of learners' activities based on their learning preferences and VARK- & ARK-based course materials.....  | 134        |
| 6.3.1.3  | Discussion of findings.....  | 135        |
| 6.3.2  | <i>Data Analysis and Finding on learners' performance based on A<sub>L</sub>ELS and PEELS</i>  | 136        |
| 6.3.2.1  | Results of learners' performance based on A <sub>L</sub> ELS and PEELS.....  | 136        |
| 6.3.2.2  | Discussion of findings.....  | 139        |
| 6.3.3  | <i>Conclusion on this section</i> .....  | 144        |
| 6.4  | DATA ANALYSIS AND FINDING – CATEGORISATION OF LEARNERS OUTCOME BASED ON THE TYPE OF ASSESSMENT QUESTIONS AND TYPES OF ELS.....                                   | 145        |
| 6.4.1  | <i>Analysis of learners' performance based on assessment outcomes without the consideration of their assigned type of ELS (A<sub>L</sub>ELS and PEELS)</i> ..... | 146        |
| 6.4.2  | <i>Investigation of learners' performance based on different types of ELS</i> .....  | 159        |
| 6.4.2.1  | Investigation of learners' performance based on A <sub>L</sub> ELS .....   | 159        |
| 6.4.2.2  | Investigation of learners' performance based on PEELS.....   | 165        |
| 6.4.2.3  | Comparison of learners' performance based on A <sub>L</sub> ELS and PEELS .....  | 171        |
| 6.4.3  | <i>Analysis of records based on RCU</i> .....  | 175        |
| 6.4.3.1  | Analysis of records of all responses from ELS users based on RCU .....   | 178        |
| 6.4.3.2  | Comparison of analysis of records of responses from A <sub>L</sub> ELS and PEELS users based on groups and types of questions (RCU).....                         | 181        |
| 6.5  | CONCLUSION.....  | 191        |
| <b>CHAPTER 7 CONCLUSION AND FUTURE WORK .....</b>  |  | <b>194</b> |
| 7.1  | OVERVIEW.....  | 194        |
| 7.2  | CONCLUSION AND UNDERSTANDING OF THE OUTCOME .....  | 194        |
| 7.3  | CONTRIBUTION OF RESEARCH .....   | 199        |
| 7.4  | FURTHER WORK .....   | 200        |



|                         |   |              |
|-------------------------|---|--------------|
| 7.4.1                   | Overview .....                            | 200          |
| 7.4.2                   | Areas of applicable to further study..... | 200          |
| 7.4.3                   | Latest research.....                      | 204          |
| <b>REFERENCES.....</b>  |   | <b>205</b>   |
| <b>APPENDICES .....</b> |   | <b>1-228</b> |
| <b>INDEX.....</b>       |   | <b>18-2</b>  |

## List of Figures

|   |     |
|---|-----|
| FIGURE 1: ILLUSTRATION OF CONTENT AND CONTEXT MATERIALS IN TERMS OF TYPES OF LEARNING METHODOLOGIES (REF: THE OUTCOME OF A DISCUSSION WITH PROF. L. MCKINNON ON LEARNING METHODOLOGIES, OCTOBER 2010) ..... | 20  |
| FIGURE 2: SCREEN CAPTURE OF SEARCHED INSTITUTES ON THE USE OF E-LEARNING SYSTEMS' SWITCHBOARD. ....   | 47  |
| FIGURE 3: SCREEN CAPTURE OF THE FORM USED FOR ENTERING INFORMATION ON THE TYPE OF ELS USED AT EACH HIGHER EDUCATIONAL INSTITUTION. ....   | 48  |
| FIGURE 4: A TRADITIONAL INSTRUCTIONAL DESIGN MODEL DEVELOPED BY DICK AND CAREY, 1990. ....  | 54  |
| FIGURE 5: A MODEL FOR DEVELOPING AN E-LEARNING SYSTEM (STONE AND KOSKINEN, 2002) .....  | 56  |
| FIGURE 6: A GENERIC MODEL OF SYSTEM.....  | 61  |
| FIGURE 7: CLOSED-LOOP FEED-BACK CONTROL SYSTEM .....  | 61  |
| FIGURE 8: CLOSED-LOOP FEED-FORWARD CONTROL SYSTEM.....  | 62  |
| FIGURE 9: HIGH-LEVEL VIEW OF THE SYSTEM'S NAVIGATION - 1 .....  | 66  |
| FIGURE 10: HIGH-LEVEL VIEW OF THE SYSTEM'S NAVIGATION - 2. ....   | 67  |
| FIGURE 11: RELATIONSHIP BETWEEN COMPONENTS OF A BASIC STRUCTURE OF AN E-LEARNING SYSTEM. ....   | 70  |
| FIGURE 12: COMPARISON OF LO CREATION WITH THE METHOD USED IN DATA HANDLING WITH XSL .....   | 70  |
| FIGURE 13: A BASIC TYPE OF CLOSED-LOOP FEEDBACK SCHEMATIC OF AN E-LEARNING SYSTEM FOR AN ADAPTIVE ADAPTABLE PERSONALISED E-LEARNING SYSTEM.....   | 71  |
| FIGURE 14: A BASIC HIGH-LEVEL VIEW OF AN ADAPTABLE, ADAPTIVE PERSONALISED E-LEARNING SYSTEM.....  | 72  |
| FIGURE 15: PROCESS OF UPDATES IN THE HISTORY OF LEARNING PREFERENCES (STYLES) UNIT (HLPU) .....   | 73  |
| FIGURE 16: A HIGHER-LEVEL VIEW OF THE DECISION MAKER UNIT FOR PROCESSING A LEARNING OBJECT CREATOR.....   | 75  |
| FIGURE 17: A HIGH-LEVEL VIEW OF THE E-LEARNING SYSTEM BASED ON THE LEARNER'S LEARNING STYLE.....  | 77  |
| FIGURE 18: SCHEMATIC OF A <sub>L</sub> PELS .....   | 86  |
| FIGURE 19: HIGH-LEVEL VIEW OF THE SYSTEM.....   | 92  |
| FIGURE 20: HIGH-LEVEL VIEW OF THE SYSTEM FROM THE LEARNING OBJECTS' POINT OF VIEW .....   | 94  |
| FIGURE 21: STEPS INVOLVED IN CHECKING THE USER'S AUTHENTICATION.....  | 95  |
| FIGURE 22: HIGH-LEVEL DESIGN OF THE SYSTEM FOR UPDATING THE LEARNER'S PROFILE .....   | 96  |
| FIGURE 23: CONTINUATION OF FIGURE 22. ....  | 97  |
| FIGURE 24: CONTINUATION OF FIGURE 23. ....  | 98  |
| FIGURE 25: LEARNER NAVIGATION MAP THROUGH THE ELS. ....   | 99  |
| FIGURE 26: NAVIGATION MAP FOR THE LEARNER WITHIN PEELS. ....  | 100 |
| FIGURE 27: CONTENT MATERIAL PRESENTER AND ACTIVITY TRACKING SYSTEM. ....  | 103 |
| FIGURE 28: AN ILLUSTRATION OF TWO DIFFERENT PERSPECTIVES OF HUMAN-COMPUTER INTERACTION.....   | 109 |
| FIGURE 29: DETAILED STRUCTURE OF A MODULE (FOR EXAMPLE) NAVIGATION WITH THE SUPPORT OF LEARNING OBJECTS. ....   | 122 |
| FIGURE 30: FIGURE LOLC: LEARNING OBJECT AND CONTENT MATERIAL BASED ON VARK.....   | 123 |
| FIGURE 31: FIGURE LO-ARK: LEARNING OBJECT AND CONTENT MATERIAL BASED ON ARK .....   | 123 |
| FIGURE 32: A DETAILED VERSION OF A SEMI-STANDARD VERSION OF A LEARNING OBJECT (LO) .....  | 124 |
| FIGURE 33: A HIGH-LEVEL DESIGN VIEW OF AN ADAPTABLE PERSONALISED E-LEARNING SYSTEM (A <sub>L</sub> PELS) .....  | 127 |
| FIGURE 34: CHART OF THE LIST OF QUESTIONS (BASED ON THEIR ID NUMBER IN THE SYSTEM) AND THEIR PERFORMANCE IN AN A <sub>L</sub> ELS .....   | 138 |
| FIGURE 35: CHART OF THE LIST OF QUESTIONS (BASED ON THEIR ID NUMBER IN THE SYSTEM) AND THEIR PERFORMANCE IN AN PEELS.....   | 138 |
| FIGURE 36: CHART OF CONTENTS FROM TABLE 21 FOR A <sub>L</sub> ELS.....  | 143 |
| FIGURE 37 CHART OF CONTENTS FROM TABLE 21 FOR PEELS. ....   | 144 |
| FIGURE 38: FREQUENCY OF LEARNERS' ATTEMPTS AT ANSWERING QUESTIONS IN EACH CLASS.....  | 153 |

|   |     |
|---|-----|
| FIGURE 39: (FIGURE FROM TABLE 27.1): PERCENTAGES OF LEARNERS' RESPONSES AND THEIR GROUP ASSESSMENTS BASED ON EACH GROUP'S TOTAL .....   | 156 |
| FIGURE 40:( FIGURE FROM TABLE 27.2): PERCENTAGES OF LEARNERS' RESPONSES AND THEIR GROUP ASSESSMENTS BASED ON THE TOTAL OF ALL ANSWERED QUESTIONS WHETHER THE ANSWER WAS TRUE OR FALSE .....                   | 156 |
| FIGURE 41:( FIGURE FROM TABLE 27.3): PERCENTAGES OF LEARNERS' RESPONSES AND THEIR GROUP ASSESSMENTS BASED ON THE TOTAL OF ALL ANSWERED QUESTIONS EITHER THE ANSWER WAS TRUE OR FALSE. ....                    | 157 |
| FIGURE 42: (FIGURE FROM TABLE 29): FREQUENCY OF A <sub>L</sub> ELS LEARNERS' ATTEMPTS ON ANSWERING QUESTIONS.....   | 160 |
| FIGURE 43: (FIGURE FROM TABLE 32.1): PERCENTAGES OF A <sub>L</sub> ELS LEARNERS' RESPONSES AND THEIR GROUP ASSESSMENTS BASED ON EACH GROUP'S TOTAL.....   | 163 |
| FIGURE 44: (FIGURE FROM TABLE 32.2): PERCENTAGES OF A <sub>L</sub> ELS LEARNERS' RESPONSES AND THEIR GROUP ASSESSMENTS BASED ON THE TOTAL OF ALL ANSWERED QUESTIONS WHETHER THE ANSWER WAS TRUE OR FALSE..... | 163 |
| FIGURE 45: (FIGURE FROM TABLE 32.3): PERCENTAGES OF A <sub>L</sub> ELS LEARNERS' RESPONSES AND THEIR GROUP ASSESSMENTS BASED ON THE TOTAL OF ALL ANSWERED QUESTIONS WHETHER TRUE OR FALSE. ....               | 164 |
| FIGURE 46: FIGURE FROM TABLE 34: FREQUENCY OF LEARNERS' ATTEMPTS TO ANSWER QUESTIONS – PELS. ....   | 166 |
| FIGURE 47: (FIGURE FROM TABLE 37.1): PERCENTAGES OF PELS LEARNERS' RESPONSES AND THEIR GROUP ASSESSMENTS BASED ON EACH GROUP'S TOTAL.....   | 169 |
| FIGURE 48: (FIGURE FROM TABLE 37.2): PERCENTAGES OF PELS LEARNERS' RESPONSES AND THEIR GROUP ASSESSMENTS BASED ON EACH GROUP'S TOTAL OF ALL ANSWERED QUESTIONS WHETHER THE ANSWER WAS TRUE OR FALSE.....      | 169 |
| FIGURE 49: (FIGURE FROM TABLE 37.3): PERCENTAGES OF PELS LEARNERS' RESPONSES AND THEIR GROUP ASSESSMENTS BASED ON THE TOTAL OF ALL ANSWERED QUESTIONS WHETHER TRUE OR FALSE.....                              | 170 |
| FIGURE 50: (FIGURE FROM TABLE 40) COMPARISON BETWEEN A <sub>L</sub> ELS AND PELS ATTEMPTED QUESTIONS IN PERCENTAGES.....  | 172 |
| FIGURE 51: (FIGURE FROM TABLE 50.1) COMPARISON OF RECORDS FROM A <sub>L</sub> ELS AND PELS USERS BASED ON GROUPS AND RECALL (R) TYPES OF QUESTION.....  | 183 |
| FIGURE 52: (FIGURE FROM TABLE 50.2) COMPARISON OF RECORDS FROM A <sub>L</sub> ELS AND PELS USERS BASED ON GROUPS AND COMPETENCY (C) TYPES OF QUESTION.....  | 183 |
| FIGURE 53: (FIGURE FROM TABLE 50.3) COMPARISON OF RECORDS FROM A <sub>L</sub> ELS AND PELS USERS BASED ON GROUPS AND UNDERSTANDING (U) TYPES OF QUESTION.....   | 184 |
| FIGURE 54: CHART ON THE COMPARISON BETWEEN A <sub>L</sub> ELS LEARNERS' NUMBER OF CORRECTLY ANSWERED QUESTIONS WITH THE TOTAL NUMBER OF ATTEMPTS ON ANSWERING QUESTIONS OF TYPE RECALL (R). ....              | 187 |
| FIGURE 55: CHART ON THE COMPARISON BETWEEN A <sub>L</sub> ELS LEARNERS' NUMBER OF CORRECTLY ANSWERED QUESTIONS WITH THE TOTAL NUMBER OF ATTEMPTS ON ANSWERING QUESTIONS OF TYPE COMPETENCY (C). ....          | 187 |
| FIGURE 56: CHART ON THE COMPARISON BETWEEN A <sub>L</sub> ELS LEARNERS' NUMBER OF CORRECTLY ANSWERED QUESTIONS WITH THE TOTAL NUMBER OF ATTEMPTS ON ANSWERING QUESTIONS OF TYPE UNDERSTANDING (U). ....       | 188 |
| FIGURE 57: CHART ON THE COMPARISON BETWEEN PELS LEARNERS' NUMBER OF CORRECTLY ANSWERED QUESTIONS WITH THE TOTAL NUMBER OF ATTEMPTS ON ANSWERING QUESTIONS OF TYPE RECALL (R). ....                            | 188 |
| FIGURE 58: CHART ON THE COMPARISON BETWEEN PELS LEARNERS' NUMBER OF CORRECTLY ANSWERED QUESTIONS WITH THE TOTAL NUMBER OF ATTEMPTS ON ANSWERING QUESTIONS OF TYPE COMPETENCY (C). ....                        | 189 |
| FIGURE 59: CHART ON THE COMPARISON BETWEEN PELS LEARNERS' NUMBER OF CORRECTLY ANSWERED QUESTIONS WITH THE TOTAL NUMBER OF ATTEMPTS ON ANSWERING QUESTIONS OF TYPE UNDERSTANDING (U). ....                     | 189 |
| FIGURE 60: A PROPOSED SKETCH FOR A LERNER PREFERENCE PROFILING (LPP) .....  | 203 |
| FIGURE 61: SCHEMATIC OF ELS .....   | 1-2 |
| FIGURE 62: SCHEMATIC OF PELS .....  | 1-4 |
| FIGURE 63: SCHEMATIC OF A <sub>L</sub> ELS .....  | 1-6 |
| FIGURE 64: SCHEMATIC OF A <sub>V</sub> ELS.....   | 1-9 |

|  |       |
|--|-------|
| FIGURE 65: SCHEMATIC OF A <sub>V</sub> PELS .....  | 1-11  |
| FIGURE 66: SCHEMATIC OF A <sub>L</sub> A <sub>V</sub> ELS .....  | 1-13  |
| FIGURE 67: SCHEMATIC OF A <sub>L</sub> A <sub>V</sub> PELS .....   | 1-14  |
| FIGURE 68: MAGNETISATION, BEFORE AND AFTER VIEWS .....   | 8-3   |
| FIGURE 69: RAYLEIGH-BENARD CONVECTION LAW .....  | 8-4   |
| FIGURE 70: A FRAMEWORK FOR THINKING ABOUT THE KNOWLEDGE IN KNOWLEDGE MANAGEMENT.<br>ADOPTED FROM: NICKOLS 2000 .....   | 9-4   |
| FIGURE 71: KNOWLEDGE CONVERSION. SOURCE: ADOPTED FROM NONAKA & TAKEUCHI (1995) ..  | 9-6   |
| FIGURE 72: CATEGORISATION OF KNOWLEDGE AND A DIAGRAM ON THE CONVERSION OF TACIT TO<br>IMPLICIT KNOWLEDGE .....   | 9-12  |
| FIGURE 73: ILLUSTRATION OF THE PROCESS OF PERSONALISATION OF STRATEGIC KNOWLEDGE<br>CREATION; UPDATING THE NICKOLS (NICKOLS, 2000) FRAMEWORK ON TYPES OF KNOWLEDGE.<br>..... | 9-13  |
| FIGURE 74: ILLUSTRATING THE RELATIONSHIP BETWEEN KNOWLEDGE TRANSFERRING (KT),<br>STRATEGIC KNOWLEDGE (SK) AND INDIVIDUAL'S LEARNING STYLE (LS) .....                         | 9-14  |
| FIGURE 75: HIGH LEVEL VIEW OF THE PROCESS OF CREATING PROCEDURAL KNOWLEDGE FROM<br>DECLARATIVE KNOWLEDGE.....  | 9-15  |
| FIGURE 76: DETAILED VIEW OF THE PROCESS OF CREATING PROCEDURAL KNOWLEDGE FROM<br>DECLARATIVE KNOWLEDGE.....  | 9-15  |
| FIGURE 77: SCREEN CAPTURE OF SEARCHED INSTITUTES ON THE USE OF E-LEARNING SYSTEMS'<br>SWITCHBOARD .....  | 10-2  |
| FIGURE 78: SCREEN CAPTURE OF THE FORM USED FOR ENTERING INFORMATION ON INDIVIDUAL<br>UNIVERSITIES' USE OF E-LEARNING SYSTEM .....  | 10-3  |
| FIGURE 79: BASIC GRAPHIC REPRESENTATION OF THE GRANULARITY OF A LEARNING OBJECT .....  | 17-6  |
| FIGURE 80: <i>STRUCTURE OF LEARNING OBJECT (LO)</i> ( <a href="http://www.macromedia.com">HTTP://WWW.MACROMEDIA.COM</a> ).....   | 17-8  |
| FIGURE 81: <i>CONTENT OBJECT MODEL</i> .....   | 17-10 |
| FIGURE 82: <i>A DETAILED VERSION OF A SEMI-STANDARD VERSION OF A LEARNING OBJECT (LO)</i><br><i>(REPEATED IN SECTION 5.5)</i> .....  | 17-13 |
| FIGURE 83: <i>POSSIBLE HUMAN-COMPUTER INTERACTION (HCI) – LEARNING PREFERENCE BASED.</i> 17-<br>14   |       |
| FIGURE 84: <i>CHART FOR CREATING THE CONCEPT OF AN EXPRESSION</i> .....  | 17-16 |
| FIGURE 85: <i>SIMPLE PROCESS OF CREATING DIGITAL ASSETS</i> .....  | 17-17 |
| FIGURE 86: <i>PROCESS OF CREATING DIGITAL ASSETS</i> .....   | 17-18 |
| FIGURE 87: KINAESTHETIC EFFECT .....   | 17-19 |
| FIGURE 88: TRANSITION OF DIGITAL ASSETS BY KINAESTHETIC EFFECT .....   | 17-19 |

## **List of Tables**

|  |     |
|--|-----|
| TABLE 1: FINDINGS FROM DATA STORED ON UNIVERSITIES' USE OF E-LEARNING SYSTEMS .....  | 49  |
| TABLE 2: KEY VARIABLE DEFINITIONS OF TYPES OF ELS RELATED TO THIS STUDY .....  | 80  |
| TABLE 3: STRUCTURE OF $A_{L-LP?+KA0}$ ELS'S CONDITIONS AND PROCESSES .....   | 82  |
| TABLE 4: STRUCTURE OF $P_{LP?+KA0}$ ELS'S CONDITIONS AND PROCESSES.....  | 82  |
| TABLE 5: LIST OF VARIETIES OF ELS WITH THEIR RELATED SECTION NUMBER FOR FURTHER<br>DESCRIPTION ON THEIR TYPES. ....  | 83  |
| TABLE 6: TYPES OF ELS WITH RELEVANT STATES OF CONTROLLING SYSTEM.....  | 84  |
| TABLE 7: STAGES OF TECHNIQUES AND INTERACTION BETWEEN CONTROL UNIT (DMU) AND A<br>LEARNER FOR THE $A_L$ PELS.....  | 87  |
| TABLE 8: TYPES AND METHODS OF CREATING DIGITAL ASSETS.....   | 108 |
| TABLE 9: DAC: DIGITAL ASSET CONVERSION .....   | 112 |
| TABLE 10: TABLE DAC2: SIMPLIFYING THE CONVERSION PROCESS OF DIGITAL ASSETS INTO A<br>PRINCIPAL FORMAT OF ARK-BASED SWITCHBOARD. ....   | 114 |
| TABLE 11: THIS TABLE PRESENTS THE TYPE OF DIGITAL ASSET EACH ONE SHOULD BE LINKED TO AND<br>THE REASON BEHIND IT.....  | 117 |
| TABLE 12: ARK-BASED SWITCHBOARD .....  | 118 |
| TABLE 13: LIST OF LEARNERS GROUPED BY THEIR ACTIVITY TIME SPEND ON EACH TOPIC.....   | 131 |
| TABLE 14: LIST OF GROUPS OF LEARNERS DIVIDED INTO DIFFERENT TYPES OF E-LEARNING SYSTEMS<br>.....   | 132 |
| TABLE 15: OUTCOME OF RELATIONSHIP BETWEEN ASSESSMENT PERFORMANCE ON THE BASE OF<br>LEARNING PREFERENCES AND ARK-BASED CONTENT MATERIALS.....   | 134 |
| TABLE 16: LIST OF QUESTIONS AND LEARNER'S OUTCOME OF ASSESSMENTS .....   | 137 |
| TABLE 17: LIST OF ASSESSMENT QUESTIONS AND THEIR RELATED TOPICS, SUBJECTS, LEARNING<br>OBJECTS, CONTENT OBJECTS AND THEIR TYPES BASED ON (RECALLING, UNDERSTANDING AND<br>COMPETENCY)..... | 140 |
| TABLE 18: OUTCOME OF RECALL-BASED TYPE OF ASSESSMENT .....   | 141 |
| TABLE 19: OUTCOME OF COMPETENCY-BASED TYPE OF ASSESSMENT.....  | 142 |
| TABLE 20: OUTCOME OF UNDERSTANDING-BASED TYPE OF ASSESSMENT.....   | 142 |
| TABLE 21: OUTCOME OF COMPETENCY-BASED ASSESSMENTS BASED ON DIFFERENT TYPES OF ELSs.<br>.....   | 143 |
| TABLE 22: LEARNERS' ATTEMPTS AT RESPONDING TO ASSESSMENT QUESTIONS.....  | 149 |
| TABLE 23: SETTING UP GROUPS OF LEARNERS BASED ON THEIR ATTEMPTS AT ANSWERING<br>QUESTIONS.....   | 152 |
| TABLE 24: PROCESS OF FINDING THE MEAN OF EACH CLASS OF ATTEMPTED ENTRIES FOR GROUPING<br>LEARNERS BASED ON THEIR ATTEMPTS TO ANSWER THE ASSESSMENT QUESTIONS. ....                         | 152 |
| TABLE 25: LIST OF LEARNERS IN EACH GROUP .....   | 154 |
| TABLE 26: NUMBER OF LEARNERS IN EACH GROUP AND NUMBER OF THEIR RESPONSES TO<br>ASSESSMENTS .....   | 154 |
| TABLE 27: PERCENTAGES OF LEARNERS' RESPONSES AND THEIR GROUP ASSESSMENTS BASED ON<br>DIFFERENT TYPES OF TOTAL.....   | 155 |
| TABLE 28: COMPARISON OF LEARNERS' LEARNING PERFORMANCE.....  | 158 |
| TABLE 29: NUMBER OF $A_L$ ELS LEARNERS IN EACH GROUP.....  | 160 |
| TABLE 30: LIST OF $A_L$ ELS LEARNERS IN EACH GROUP BASED ON THE NUMBER OF QUESTIONS<br>ANSWERED (WHETHER TRUE OR FALSE) .....  | 161 |
| TABLE 31: THE NUMBER OF $A_L$ ELS LEARNERS IN EACH GROUP AND THE NUMBER OF THEIR<br>RESPONSES TO ASSESSMENTS.....  | 161 |
| TABLE 32: PERCENTAGES OF $A_L$ ELS LEARNERS' RESPONSES AND THEIR GROUP ASSESSMENTS<br>BASED ON DIFFERENT TYPES OF TOTALS .....   | 162 |
| TABLE 33: COMPARISON OF LEARNERS' LEARNING PERFORMANCE FOR $A_L$ ELS USERS.....  | 164 |
| TABLE 34: NUMBER OF PELS LEARNERS IN EACH GROUP.....   | 165 |
| TABLE 35: LIST OF PELS LEARNERS IN EACH GROUP BASED ON THE NUMBER OF QUESTIONS<br>ANSWERED (WHETHER TRUE OR FALSE) .....   | 166 |
| TABLE 36: THE NUMBER OF PELS LEARNERS IN EACH GROUP AND THE NUMBER OF THEIR<br>RESPONSES TO ASSESSMENTS.....   | 167 |

|   |      |
|---|------|
| TABLE 37: PERCENTAGES OF PELS LEARNERS' RESPONSES AND THEIR GROUP ASSESSMENTS<br>BASED ON DIFFERENT TYPES OF TOTALS .....   | 168  |
| TABLE 38: COMPARISON OF LEARNERS' LEARNING PERFORMANCE FOR PELS USERS .....   | 170  |
| TABLE 39: COMPARISON OF LEARNERS' PERFORMANCE BASED ON TYPE OF ELSS AND TYPE OF<br>ANSWERED QUESTIONS .....   | 171  |
| TABLE 40: COMPARISON OF THE NUMBER OF LEARNERS' PERFORMANCE BASED ON THE ATTEMPTED<br>QUESTIONS FOR BOTH TYPES OF A <sub>L</sub> ELS AND PELS.....                          | 172  |
| TABLE 41: COMPARISON OF NUMBER AND TYPE OF ANSWERED QUESTIONS BETWEEN TWO SYSTEMS<br>.....  | 173  |
| TABLE 42: COMPARISON OF THE NUMBER AND TYPE OF ANSWERED QUESTIONS BETWEEN TWO<br>SYSTEMS IN THE FORM OF PERCENTAGES .....   | 174  |
| TABLE 43: ASSESSMENT (NOT PRACTICE) TYPE OF QUESTIONS AND THEIR RESPONDS.....   | 176  |
| TABLE 44: COMPARISON OF LEARNERS' RESPONSES TO RCU TYPE OF QUESTIONS BASED ON BOTH<br>ELSS.....   | 178  |
| TABLE 45: COMPARISON OF LEARNERS' CORRECT RESPONSES TO RCU TYPE OF QUESTIONS BASED<br>ON TWO ELSS.....  | 178  |
| TABLE 46: COMPARISON OF LEARNERS' INCORRECT RESPONSES TO RCU TYPE OF QUESTIONS<br>BASED ON TWO ELSS.....  | 179  |
| TABLE 47: ALELS USERS AND COMPARISON OF THEIR ACTIVITIES BASED ON DIFFERENT GROUPS AND<br>TYPES OF QUESTIONS (RCU).....   | 180  |
| TABLE 48: PELS USERS AND ANALYSIS OF THEIR ACTIVITIES BASED ON DIFFERENT GROUPS AND<br>TYPES OF QUESTIONS.....  | 180  |
| TABLE 49: ALELS AND PELS USERS' ASSESSMENT OUTCOME AND COMPARISON OF THEIR<br>ACTIVITIES BASED ON DIFFERENT GROUPS AND TYPES OF QUESTIONS (RCU).....                        | 181  |
| TABLE 50: COMPARISON OF ALELS AND PELS USERS' ASSESSMENT OUTCOME BASED ON<br>DIFFERENT FREQUENCIES OF LEARNERS IN EACH GROUP AND TYPES OF QUESTION SEPARATELY<br>(RCU)..... | 182  |
| TABLE 51: COMPARISON OF CORRELATION COEFFICIENT BETWEEN DIFFERENT TYPES OF<br>ASSESSMENT QUESTIONS AND THEIR USE IN DIFFERENT TYPES OF ELSS.....                            | 190  |
| TABLE 52: STAGES OF TECHNIQUES AND INTERACTION BETWEEN CONTROL UNIT (DMU) AND A<br>LEARNER FOR THE ELS.....   | 1-3  |
| TABLE 53: STAGES OF TECHNIQUES AND INTERACTION BETWEEN CONTROL UNIT (DMU) AND A<br>LEARNER FOR THE PELS. ....   | 1-5  |
| TABLE 54: STAGES OF TECHNIQUES AND INTERACTION BETWEEN CONTROL UNIT (DMU) AND A<br>LEARNER FOR THE PELS. ....   | 1-7  |
| TABLE 55: STAGES OF TECHNIQUES AND INTERACTION BETWEEN CONTROL UNIT (DMU) AND A<br>LEARNER FOR THE A <sub>V</sub> ELS. ....   | 1-10 |
| TABLE 56: STAGES OF TECHNIQUES AND INTERACTION BETWEEN CONTROL UNIT (DMU) AND A<br>LEARNER FOR THE A <sub>V</sub> PELS.....   | 1-12 |
| TABLE 57: STAGES OF TECHNIQUES AND INTERACTION BETWEEN CONTROL UNIT (DMU) AND A<br>LEARNER FOR THE A <sub>L</sub> A <sub>V</sub> ELS. ....                                  | 1-14 |
| TABLE 58: STAGES OF TECHNIQUES AND INTERACTION BETWEEN CONTROL UNIT (DMU) AND A<br>LEARNER FOR THE A <sub>L</sub> A <sub>V</sub> PELS. ....                                 | 1-15 |
| TABLE 59: FINDINGS FROM DATA STORED ON UNIVERSITIES USE OF E-LEARNING SYSTEMS.....  | 10-3 |

## **Abbreviations**

A: Auditory - Audio

AAELS: Adaptive-Adaptable E-Learning System

AAPELS: Adaptive-Adaptable Personalised E-Learning System

A<sub>I</sub>ELS: Adaptable E-Learning System

A<sub>I</sub>PELS: Adaptable Personalised E-Learning System

A<sub>V</sub>ELS: Adaptive E-Learning System

A<sub>V</sub>PELS: Adaptive Personalised E-Learning System

AC: Assessment Content

CM: Content Material

CMs: Content Materials

CMS: Content Management System

ELS: E-Learning System

K: Kinaesthetic (and tactile learning preferences)

KA: Knowledge Assessment

LC: Learning Content

LO: Learning Object

LOs: Learning Objects

LP: Learning preferences

PC: Practice Content

PELS: Personalised E-Learning System

R: Reading (and writing content materials)

V: Visual

## Key Terms

This is important to say that following key terms are only related to this research. Since, it is imparitive to mention that those definitions could mean differently by other researchers for different purpose.

Types of e-learning systems: In this research three major types of e-learning systems (ELS) where investigated, adaptive ELS, adaptable ELS and personalised e-learning systems.

Adaptive e-learning systems: An e-learning system which system is on control of learner's learning environment.

Adaptable e-learning systems: In an adaptable e-learning system users can modify their settings – mainly learning styles - in the system's environment.

Personalised e-learning systems: It is a type of e-learning system similar to adaptable e-learning system but once learning style of learner is determined, then learner can't change his/her learning preferences.

Learning styles: A learning chatactristic of a learner which determines the way a learner can interact with learning materials.



## **Chapter 1 Introduction**

### ***1.1 Overview***

This chapter provides a brief background to the study at hand to investigate the effects of adaptivity of e-learning systems on learners' learning performance in comparison to traditional classroom teaching. The chapter also outlines the aims and objectives of this research in the form of a hypothesis, the methodology of how this project is done and a summary of what each chapter contains.

### ***1.2 Background to the Study***

Innovation in technology and communication is changing the structure of teaching and learning today. Wentling, Waight, Gallaher, La Fleur, Wang and Kanfer (2000) describe how several terms have been used to characterise the innovation and creation that has been occurring. Some of these terms include web-based learning, online learning, distributed learning, e-learning and computer-based instruction to name but a few. Although there have been many promises made about the e-learning revolution using state-of-the-art multimedia technology, closer scrutiny of what is being delivered reveals that many of the e-learning models that are around are little more than the old text-based computer-aided learning running on a global network. This study investigates the existing models of e-learning systems (ELSs) with a view to designing, developing and evaluating an adaptive e-learning system in comparison to traditional teaching classrooms.

Furthermore, when exploring the literature, it soon becomes clear that terms like web-based learning, e-learning and hypermedia-aided learning are still fuzzy and do not have a standardised definition. Whilst online learning might be considered as a subset of e-learning, they might be synonymous from a different perspective. Computer-aided instruction can be an all-encompassing term used to describe different forms of computer-based delivered instruction including CD-ROM and the World Wide Web. However, it can also be seen as a more restrictive term used to describe the old-fashioned, text-only computer-based training. Wentling et al. (2000) point out that the various definitions that exist show a great depth of interdependence between them. This form of learning currently depends on networks and computers but will likely evolve into systems consisting of a variety of channels (e.g., wireless and satellite), and technologies (e.g., cellular phones and PDAs) as they are developed and adopted. E-learning can take the form of courses as well as modules and smaller learning objects. E-learning may incorporate synchronous and asynchronous access and may be distributed geographically with varied time limits. In all the above, the pedagogical and social interaction of learners within such learning environments should also be considered, while finding a unified term for the definition of e-learning.

This study is concerned with the adaptivity of a web-based learning (WBL) environment within the context of e-learning concepts. When attempting to define web-based training (WBT), Horton (2000) explains that some e-learning designers limit WBT to take place entirely within a web browser, without the need of other software or learning resources. This restriction, however, leaves out many of the truly effective uses of web technologies for learning, such as audio and video technologies, as a means of content delivery. Mioduser, Nachmias, Oren and Lahav (1999) assert that web-based learning environments are the result of educators' attempts to wrap

together web technology features (e.g., information manipulation, communication and creation tools) according to their educational and pedagogical beliefs and pursued learning goals. Anderson (Anderson et al., 1999) identifies that these learning networks are comprised of professors and students communicating with each other in real time (synchronously) and off-line sequentially (asynchronously).

### ***1.3 Hypothesis***

This section sets out the initial aims and objectives of this research. The study has formulated the following hypothesis as the research question to be investigated:

**Hypothesis:** Adaptive e-learning systems (learner-centred e-learning systems) are more effective than traditional teacher-centred e-learning systems in terms of the efficiency of learning and the delivery of learning content materials.

To prove or disprove this hypothesis, a research methodology was adopted which is described in the next section.

### ***1.4 Aims and Objectives of this Research***

This section sets out the initial aims and objectives of this research, which will become clearer through this thesis. As mentioned earlier (section 1.3), the goal of this research is to evaluate an adaptive e-learning system in comparison to a traditional classroom teaching. This comparison will be done by measuring learners' learning

performance. Therefore, the aims and objectives used to investigate the hypothesis of this study are as follows:

- a. To investigate what a traditional teacher-centred e-learning system is.
- b. To investigate what the adaptivity of e-learning system means.
- c. To seek the feasibility of the design and development of an adaptive e-learning system, so to measure learners' learning performance in comparison to teacher-centred e-learning systems.

To prove or disprove the hypothesis, a research methodology was adopted which is described in the next section.

## **1.5 Methodology**

Having identified the hypothesis, the research methodology for this project covers the following approaches and activities:

- Investigation of the UK's existing online learning systems' providers, and their methods of delivery of content materials. The aim of this process is to learn about any current adaptive e-learning systems practised in the UK's higher educational institutions (universities and colleges) in order to help the feasibility study for this research.
- In this research the feasibility of an adaptive e-learning system is being studied to investigate the effectiveness of such systems on learners' learning performance in comparison to that of traditional teaching classrooms.

- The next step would be refining the hypothesis to reflect new understandings of the topic under research.
- Modelling the architecture of a new version of an e-learning system, which investigates learners' interaction with the adaptive e-learning system under research.
- The newly designed and developed adaptive e-learning system involves creating newly structured and developed content materials, so to be compatible with the newly designed and developed e-learning environment.
- Developing the experimental and evaluation methods as a road map towards analysing learners' activities and measuring their learning performance.

The structure of this thesis is a combination of six chapters excluding references and appendices.

## ***1.6 Chapters of the thesis***

Chapter 1: introduction and description of what this thesis is all about.

Chapter 2: This chapter debates the history and current state of e-learning systems alongside the concept of adaptivity and adaptive e-learning systems.

Types of e-learning systems investigated in this research are influenced by the role of learning philosophies and the measure of control given to either the learner or the learning environment. This chapter also discusses a survey into the use of adaptive

learning environments in Higher Education and as a result of that survey in addition to the digestive understandings from the literature, the hypothesis has been revised.

Chapter 3: This chapter discusses methodologies for the design of e-learning systems and the rational behind the relationship between the physiological learning preferences and design process of assessment questions. The chapter also discusses closed loop control systems and how these can be used in e-learning systems.

Chapter 4: This chapter outlines the eight types of possible e-learning systems that could be designed and developed. The reason for having eight types is because of eight possible combinations of adaptivity, adaptability and personalisation of e-learning systems. All those systems are studied from an engineering point of view as they are types of closed-loop controlling systems. Also included in this chapter is a description of why a type of closed-loop control system is used for the e-learning system under research, which requires an understanding of the principles of such systems (i.e. feed-back and feed-forward closed-loop control systems) from a system engineering point of view. The study continues by discussing the components of the content provider system, which is used for repackaging of content materials, the decision maker unit which is the continuation of the concept of controlling unit, and at the end the framework for designing assessment questions.

Chapter 5 – The design of the e-learning system under study is provided in this chapter. It includes proposals and decisions made in the design phase of developing an adaptable personalised e-learning system. A new method of assembly is proposed to make the production of content materials feasible. The discussion of assessment material is also discussed in this chapter.

Chapter 6 – the outcome and data analysis of learners’ interaction with the system is included in this chapter. It aims to present evidence on the hypothesis established in section 2.8 to provide a relationship between learners’ learning performance and an e-learning system which is designed based on learners’ learning style.

Chapter 7: this chapter presents the conclusion and suggestions for further work. It provides a concluding remark about this research and discusses any lessons that have been learned.

In this regard two conference papers have been published which can be found in Appendix 11 and Appendix 12.

## **Chapter 2      Literature Review**

### **2.1 Overview**

In this chapter, electronically-based knowledge-transfer systems known as e-learning systems are reviewed and evaluated. The need for learning and teaching philosophies and on that basis, the reason for why the understanding of the measure of control given to either learner or the learning environment can determine the type of learning system are discussed in this chapter. Issues involved in the definition and concepts of adaptive e-learning systems (A<sub>v</sub>ELS) are discussed. The aim of this chapter is to explore the definition and design of an ELS, and how these differences in e-learning systems' structural design can be used towards the design and development of an adaptive e-learning system. This study continues with identifying the need for adaptivity of a learning environment and how it can be achieved by modifying an e-learning system. Further investigation of the concept of adaptivity and types of e-learning system leads to the refining of a set of specified hypotheses as discussed in section 1.3.

### **2.2 Background to Learning and E-Learning Systems**

There are arguments that exist regarding the definition and starting point of learning systems and they could be categorised into two different types: (i) those that use only a paper-based method of communication for their medium of knowledge transfer with the support of the postal service (mostly known as traditional distance learning), and (ii) those which involves some sort of electronically-based method of communication.



Through the methods of communication mentioned above, knowledge is transferred in any format (Horton, W. 2001), whether by the support of purely paper-based methods (as originated by Sir Issac Pittman in 1840 (Aranda, N., 2007) to provide a course in Shorthand Writing – the start of distance learning) or by the use of digital media sources which involve extremely complicated methods of delivery of learning materials online.

The use of computers and the availability of web technologies in different formats created the necessary groundwork for the first wave of e-learning systems where the learner would have access to all necessary course materials through the use of a learning management system, which acts as guidance towards his/her learning activities. Although there has been a variety of approaches to the use of technology for knowledge transferring to learners (on-line education), experts are convinced that the Vannevar Bush paper (Bush, V., 1946) was the first initiative that used machines to support a hypertext-like device called the “Memex”. However, there were many pitfalls and arguments that they did provide sufficient support to learners in terms of providing pedagogically-based courses (Vita, A.D., 2007).

Even though, with the involvement of electronically-based (not mechanically machine-based) technological learning started in the early 1960s. From the 1960s through to the early 1980s, technology was mostly used to replace existing one-to-one or face-to-face traditional classes. During the 1980s (after 1983) and during the early 1990s a few different approaches were tried out but they did not survive long, as they only transferred existing paper-based teaching materials into digitally-based course formats such as cassettes, CDs and video (Horton, W., 2001; Aranda, N., 2007).

The comments above are those which are relevant to this study; however, a quality list of detailed discussions on the history of distance learning and the involvement of technology in education (educational technology) can be accessed online via different sources starting with the wikipedia.org (History of VLEs, 2009) website.

With the growth of the World Wide Web, advancements in network technologies clearly created an environment that the first wave of e-learning systems supported. For example, synchronous and live online discussions, which had not been possible before then, were of great use in technologically-based learning systems. Although the telephone line had almost replaced the offline types of collaborative paper-based discussions, the cost was usually a burden on the users of e-learning systems at both ends. From 1994 to 1999, the development of e-learning systems with the support of internationally interconnected computers, the progression of multimedia and media players, the capabilities of streaming audio and video, and the use of email, which is counted as a major breakthrough in the use of technology in education, generated a vacuum for researchers in the field of instructional design to study further the use of hypermedia in the field of education. These studies guided the development of online learning environments into the second wave of e-learning systems (Wiley, D. A., 2000; Taylor, 2002). From 2000 to 2005, researchers studied, designed and developed hypermedia-embedded learner-centred and personalised e-learning environments which tried to get more involvement of learners' learning styles into existing e-learning systems (Aranda, N., 2007; Vita, A.D., 2007).

The main topic concerning the development of e-learning systems was pedagogical issues, which became learning issues rather than teaching ones. By this, we mean that the concept of andragogy (adult learning) and then heutagogy (learner-centred

learning) came in. For the first time, an educational correspondence developed in the United States, France, Germany and the United Kingdom (Moore M. G. and Kearsley G. 1995) to study and apply the theoretical findings of an e-learning system. Its methods were developed by the consideration and use of the Computerised Educational System (CES). As its name suggests, CES is a combination of educational materials presented online by the use of electronically-based technology.

Although the internet provided enough tools for developing online materials such as HTML and other plug-ins such as adding audio and video to a presentation, still much more work needed to be done. The lack of an appropriate use of pedagogical methods throughout the process of developing an online course has caused many projects to waste resources either financially or in terms of man hours, as they did not have enough stability and flexibility to develop further (Stone, D. E. and Koskinen, C. L., 2002).

Before proceeding further, it is necessary to provide the background of current learning philosophies and methods of instructional designs. Then the issues related to the delivery of knowledge online such as the use of e-learning systems will be discussed. The following section discusses the advantages and disadvantages of such mechanisms.

### **2.2.1 Learning Processes and Need for Learning and Teaching Philosophies**

This section evaluates the existing learning philosophies and instructional design systems based on: (i) traditional face-to-face classrooms and (ii) online learning classes (e-learning systems). The analysis will then provide an overview of learning

systems, followed by a summary of advantages and/or disadvantages of developing such systems.

Although Skinner's behaviourism, Piaget's cognitive constructivism and Vygotsky's social constructivism can all be facilitated through e-learning, their works lead to the finding of evidence that supports the hypothesis presented in section 1.4 (detailed descriptions can be found on section Appendix 15). Arney (Arney D., 2005) has provided a short list of points (see below) regarding the relationship between the teacher, the knowledge and the learner. It is not a comprehensive list; it only presents the main ideas about the relationships in order to establish a framework to learn more about the philosophies of learning and teaching:

- Learning needs a medium in which to occur as it can't happen in a vacuum
- Needs exist between the learner and the identified knowledge
- While assessing a learner's knowledge, questioned materials must be relevant to the learner
- The process of learning is usually facilitated by moving from the known to the unknown
- By having an emotional connection between the learner and the material, real learning can take place
- Another important issue is the social environment, which influences learning
- Memorising alone can't be called learning
- Different learners, different methods and ways of learning

Based on the theory of constructivism, humans construct their own knowledge instead of simply being a passive learner and merely receiving information.

For the past decade many learning models have been proposed in learner-centred educational systems (Menges 1994; Felder & Brent 1996; Locatis & Weisberg 1997; Sandholtz et al. 1997; Wolf et al. 1998; Svensson, L. et al., 2010). Recently many developments have been made in one of the important branches of the Internet and multimedia, known as the field of educational models. Instructional designers and learners have become more obsessed with using the World Wide Web to advance their knowledge in today's fast-growing need for skilled people in academic and commercial environments. Despite the fact that considerable research into educational psychology has been carried out for the past decade, we still do not have a set of fully defined e-learning characteristics. Thus for clarification in establishing the unified terms and arguments made in this research, it seemed necessary to review a few methods of instructional designs.

### **2.2.2 Methods of Instructional Design**

While searching through the existing instructional designs, three major methods come to light, the first two of which are:

***i) Pedagogy (teacher-centred) and ii) Andragogy (adult-centred) based learning environments:***

The origin of the word 'pedagogy' comes from the Greek words "paid" meaning child and "agogos" meaning leading. Thus pedagogy means the art and science of leading and teaching children (Hiemstra & Sisco, 1990; Somerville, M.J. 2010). In this method students are given a set of predefined instructions to perform a set of tasks. The students are not given any option in terms of how or in what order to learn. Students have to go through those contents determined by their teacher. The main pitfall of this method is that the whole purpose of this educational method is to prepare students to show a level of competency in getting a grade to pass

the minimum level of competency (designed and developed by the teacher) and then progress to the next level (Hill, L.F., 1991).

Malcolm S. Knowles (1968, 1975, 1980, 1984; Knowles & Associates, 1984), was the main force behind popularizing the concept of Andragogy or adult-centred learning environment as a new method of instructional design. Since this method is mainly designed to teach adults, approach towards interacting with them is different from pedagogy. The main factor is in the use of metacognition, as children are not mature enough to be equipped to handle this approach. Since children are mostly taught to do certain things, towards their education, adults expecting to be treated in a such a way where they to be given an opportunity to find their ways on taking action on doing things, since they are adult and they want to take control of their learning with confirmation received in the form of a continuous guidance for an expert in the field.

Knowles (Knowles, 1980, pp. 44-45) introduced four main concepts in the definition of andragogy, which with the support of his colleagues were then updated to six (Knowles, Holton and Swanson, 1998) assumptions (Reischmann, Jost, 2004 and Fidishun, D., 2000), and they are as follows: (i) the learner's need to know: this is a step towards guiding learners to find out about their specific needs; (ii) the role of the learner's experience: while progressing through the contents of taught materials, learners would create a reservoir of experiences which can be used later on to build learning; (iii) the learner's readiness to learn: as students' willingness to learn increases, including further social interactions, they will be more co-operative, collaborative and supportive; (iv) the learner's orientation to learning: another key component of andragogical philosophy of learning is related to its approach to apply knowledge immediately rather than postpone it to another time, and the change of perspective from subject-centred to performance-centred; (v) the learner's self-

concept: self-description moves from teacher-dependent thinking to independent and more self-directed (which lately has become the ‘heutagogy’ method of instruction; more will follow); (vi) the learner’s motivation to learn: there may be external factors to encourage the learner to learn, but the motivation should come from within; examples might be increased self-esteem, job satisfaction and quality of life.

The core approach in andragogy is the guidance of students in “learning how to learn”, which gives the responsibility of learning to the learner and as such, they will be held accountable for their own learning. Furthermore, this instructional method is fundamental to another learning strategy known as problem-based learning (PBL) which challenges students to learn how to learn, working cooperatively in groups to seek solutions to problems (Duch, Groh and Allen, 2001; Jeffries, W.B., Huggett, K.N., 2010).

In other words, in the pedagogical approach, the knowledge will be transferred to the learner in a teacher-centred environment where the teacher is responsible for preparing the knowledge in such a way as s/he sees fit without considering an individual learner’s learning style. On the other hand, the learner-centred approach is a method of knowledge delivery where knowledge is prepared, and the learner is able to take responsibility for his/her own learning under the supervision of a relevant tutor (Wagner & McCombs, 1995 and LeJeune, N. F., 1998; Chianga, C.K. et al R. 2010). However, this approach can create many additional issues such as: intentional learning, active learning, authentic learning, open learning, and many more which are covered in the original reference (LeJeune, N. F., 1998; Vu, K.L. 2011).

***Beyond Pedagogy and Andragogy and moving towards Heutagogy:*** Hase and Kenyon (Hase & Kenyon, 2000), with the support of Rogers’ (1969) statements on the

use of a learner-centred approach, suggest that lifelong learning is a human desire and they indeed argue that teacher-centred learning has been over-emphasised through the history of education. As such, Hase, Kenyon and Rogers have pointed out a five key hypothesis as follows: (i) a learner can't be taught directly, and all teachers can do is facilitate learning; (ii) the only components of teaching materials that are learned by learners are those that can directly enhance their lives; (iii) a learner's nature tends to resist the changes of self through denial or distortion of symbolisation, and then it becomes more rigid under continuous threat; (iv) a learner accepts a new inconsistent experience with their current state of knowledge, only when the self is ready to accept it; (v) as such, the effect of the threats of learned materials on the current state of significant learning should be kept to a minimum, to overcome the process of self-directing while receiving new knowledge (in the form of learning).

**iii) Heutagogy (*Learner-centred Learning*):** On the basis of the argument made above, a new method of transferring knowledge to the learner has been introduced known as heutagogy. Heutagogy is the principle of teaching based upon the concept of truly self-determined learning. In this method it is assumed that adult learners (defined as eighteen years old and above) have the capability of self-motivation and self-determination to manage their own skills and knowledge needed to survive in the twenty-first century. It is assumed that this approach would foster an individual learning approach on the basis of the self-analysis of learners' own needs (Hase, S. & Kenyon, C., 2000; Hase, S. 2009).

***Selection of the correct strategic learning perspective:*** As stated above, it is essential to consider which one of the above knowledge transferring strategies should be



chosen before designing any instructional system. Besides, to learn more about the kind of strategy to choose from, understanding of learning philosophies would help determine the scope and boundary of the required system to facilitate the process of designing an e-learning system.

There are many different learning philosophies that exist, and one of the major ones is behaviourism which relates to the observable behaviours of the learner rather than mental activities (Pavlov, I. P., 1899; Skinner, B. F., 1938). On the other hand, Mead (1932/1977) and Vygotsky (1934/1978) have classed the communicative method of interaction as a main factor of cognitive growth. In this school, mental construction in the minds of learners are described as knowledge and viewed as symbolic, and while the process of committing these symbolic representations to memory is called learning, they may be processed further by the learner to produce new information and knowledge. Strict “input – processing – output architecture” of computer development from the 1960s up to today have certainly stimulated these “information processing” views of learning (Siemens G., 2005). In addition to the above-mentioned learning philosophies, there is the school of constructivism which emphasises the building (i.e., constructing) of knowledge that occurs in people's minds when they learn. A simple way to explain this idea is to refer to Gestalt theory (Dabbagh, 1999; Glatzeder, B.M. et al. 2010); that is, the idea that “a whole is more than the sum of its parts”. This school of philosophy focuses on preparing the learner for problem solving in ambiguous situations. Other major learning philosophies which are relevant to this study are included in Appendix 15.

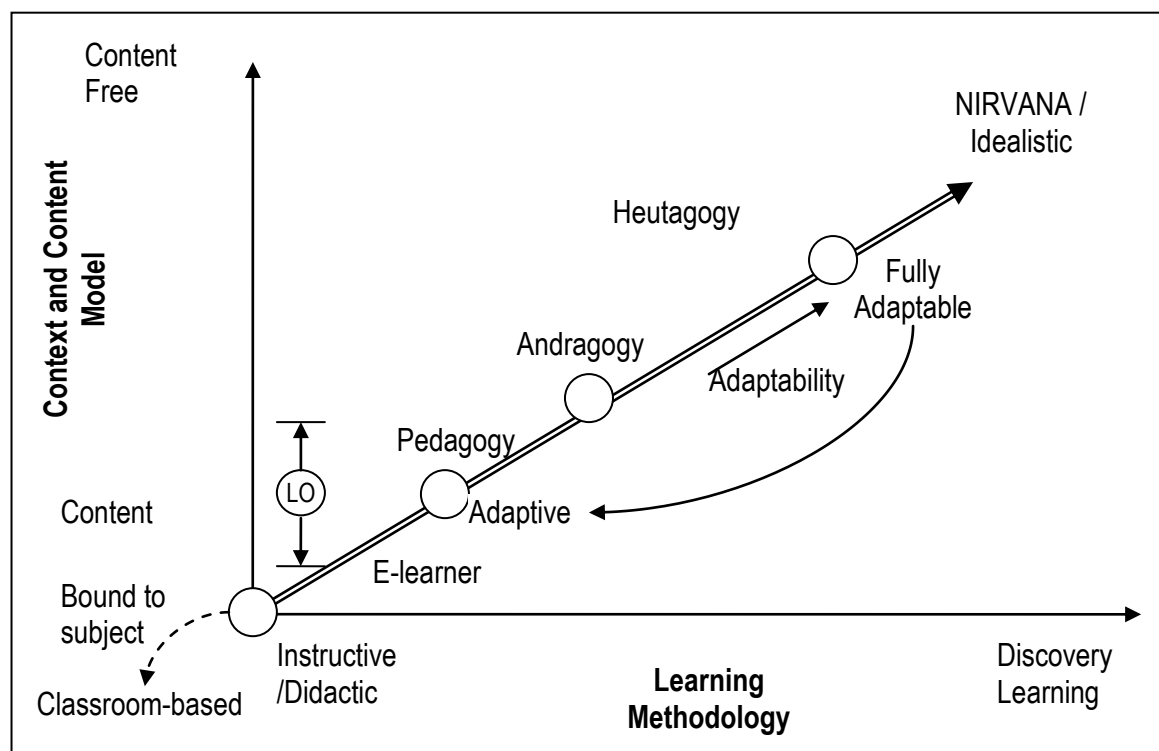
### **2.2.3 Child-, adult-, learner- and teacher-centred learning environments**

As discussed in the sections above (2.2.1 and 2.2.2), the core difference between different types of learning environment is who is in control of that learning environment. Understanding of this factor determines the type of strategy we need to choose for any type of e-learning system to be used by its instructional designer and its users.

Since in cognitivist and constructivist schools the mind of the student is under study, the level of metacognition plays an important factor here. A child-centred approach will result in a pedagogic method which is known as a teacher-centred method since a child does not hold the need for having a specific goal in his/her education because child metacognition has not grown enough to understand that need. On the other hand, most adults are different since they understand the need for learning something new in addition to whatever knowledge they already hold, including the knowledge of how to learn, but still the support of a teacher is needed to give students a helping hand to strengthen their confidence in overcoming that learning process and the rationale for learning, as well as the content. The heutagogical method is different in that the learner does not need a helping hand since they have already gained that proficiency in searching for what is needed and then setting the required objectives so that they can direct their activities towards getting to that goal. The element of 'proficiency' makes the difference between the levels of understanding of adults while moving from the stage of andragogy towards heutagogy, and that skill and knowledge (proficiency) can be gained through supervision under andragogical learning environment however, it is not a step every adult learner can take. There is always a

crossover between different instructional methods as these are not absolutely discrete. For instance, in the heutagogical method, there is still an element of pedagogy involved in the teaching materials, since an expert in the field will have prepared structured content material in the form of an article which will have been used by a teacher in structured learning material. In adult-centred learning (andragogy), there is a rationale and a metacognition aspect involved, which begins with metacognition, as pedagogy is instructivist to a large extent. It indicates that in both andragogy and heutagogy the role of the tutor changes to an instructional designer, rather than a teacher as in the pedagogical method, since it is a didactical and instructivist approach. In andragogy it is anticipated to help students to achieve a level of metacognition or the measure of control needed to take the learner to the stage where s/he is capable of learning how to learn, which is the first step towards a lifelong learning environment. Unlike in heutagogy, it is expected that the learner already has that skill and knowledge. As seen in Figure 1, the approach taken towards underpinning the relationship between stages of learner control over his/her learning can be mainly divided into multiple stages of pedagogy, andragogy and heutagogy. In that respect, the context and content of learning materials (either to be delivered to or be accessed by the learner) is in direct relationship with the type of learning methodology. For example, the format of a learning object (such as its size and content it holds) is mostly in direct proportion to an instructive/didactic type of learning methodology and its content is structured accordingly. On the other hand, since adaptability means giving a learner the necessary control over his/her learning process, the learning methodology used in designing a learning process moves from instructive/didactic approach towards discovery learning. In that respect, the scope of context and the format of its content materials is in direct proportion to the amount of

control given to a learner over his/her learning. Thus, if a learner is given total control over the selection of the context and content of learning materials, and thereby experiences discovery learning, it implies a heutagogy or fully adaptable (from learner's perspective) learning environment. Alternatively, if the system is in control of the learning based on the learner's learning style, and so to form the context and content of learning materials, it would be an adaptive (from both the learner and system's perspective) learning environment.



**Figure 1:** Illustration of content and context materials in terms of types of learning methodologies (Ref: The outcome of a discussion with Prof. L. Mckinnon on learning methodologies, October 2010)

### **E-learning system as a learning environment**

A learning environment known as distance learning, which is the predecessor of e-learning systems, gave an opportunity of exploration to researchers to investigate the relationship between the rationale behind methods of knowledge delivery to

students (in the form of content material) and the way in which learners receive the material and understand the purpose behind it. It has mostly been developed on the basis of pedagogical methods with the behaviouristic model. Lessons, practices and assignments are uploaded somewhere (mostly in educational institutions) so that they can be accessed by students, and the major role of the World Wide Web is to be used as a mechanism of content delivery. Recently, advancements in technology have given prospective views on a variety of methods of delivery of hypermedia-rich content materials.

As discussed earlier in chapter 1 and in this chapter, it is argued that the e-learning system under research is to be more constructivist in nature to allow learners to explore, to discover and to develop their learning environment and to gain the knowledge needed in the first place. This is the point where the concept of adaptivity begins to emerge. The ultimate goal of education is to deliver the needed knowledge to the learner, and knowledge itself needs to evolve so that it can be delivered from one mind to another. The main difference between e-learning systems is the measure of control which has been taken by whoever intends to deliver it. If a teacher requires a system to deliver content material to students, then the system utilises a pedagogical model; however, if the intention of using that system is for the delivery of teaching materials with continuous support, including the rationale of “learning how to learn”, which is mainly used for teaching adults, it follows an andragogic model. There is another model of e-learning system that exists which has not been practised much, and that is because of its fundamental concerns regarding the use of metacognition as a way of confirming that the learner is in the process of gaining knowledge. The measure of control is a sustainable issue in the process of supervision of those

learners. However, if instead of giving the task of supervision to the learner himself or herself, it can be given to the system, and if the system is responsible for continuous guidance based on the learner's learning method, then it is an adaptive e-learning system (this will be discussed thoroughly in later sections); however, because the control is out of the hand of the learner, it can't be a fully heutagogic model of learning. Hence, the next section will involve a discussion on e-learning systems and how they affect the learning environment.

#### **2.2.4 E-Learning Systems**

In this section, two types of e-learning system will be reviewed. The study of all the available and developed types of e-learning system is out of the scope of this thesis because researchers in the field have developed a tremendous number of e-learning systems and as such only a few have endured, which provides the fundamental guidance needed to develop a Learning Management System (LMS). What follows is a discussion on the definition and types of e-learning systems.

E-learning systems are forms of learning system which transfer explicit knowledge electronically to the learner (Appendix 9). This means that with the use of technology, content material in the form of digital content would be transferred via existing networked environments (LAN, WAN, use of the Internet and varieties of other network structures) to the learner. Learning materials were delivered; quizzes and assessments were run online, and the whole process of learning was arranged through a learning management system.

Whilst this is not the whole story, which has been going on for years, the misconception about LMSs is that they do all the arrangements for a learner in a

structured way to provide him/her with the knowledge possessing and processing road map; whether that process would involve the correct pedagogical method or not is another issue, and one which can be overlooked while designing such an environment. It is true that instructional designers do their best to put the best possible theories of educational knowledge into practice, but would that be enough to confirm that knowledge has been delivered thoroughly and would it be enough to confirm that the learners have learned? Another important side of any educational system is its administrative affairs, especially when the number of students grows and as a result the whole administrative workload also increases. It is true that with the support of technology, in the form of Learning Management Systems, most of the day-to-day work would be simplified; but can those systems confirm that delivery of knowledge has been done to the best of its capabilities, to the point that they could replace existing traditional classrooms with their teaching methods? And has the delivery of knowledge been compatible with the learner's learning method? A review of the two main categories of existing types of e-learning systems should answer those questions, and will help us to gain an understanding of the research in hand.

### **Computer-Aided and Computer-Based Learning Systems**

As seen in the past decade, organisations – especially educational institutions – are continuously merging the use of technology into their organisational procedures (Fischer, Savenye, & Sullivan, 2002; Kohli, 1995). In reviewing the history of e-learning systems, different approaches have been taken into account towards different uses of computer-based education (CBE) delivered by CD-ROM and computer-aided education (CAE), which is delivered via the internet, encompassing both academic and business environments (Christoph et al., 1998; Hoobveld, Paas,

Jochems, & van Merriënboer, 2001; Kirschner & Paas, 2001; Retalis & Skordalakis, 2001; Weiss, Knowlton, & Morrison, 2002).

To continue this discussion, Workman (Workman, 2004) carried out a study to find any correlation between CAE and CBE that might confirm that learners with an interest in learning abstract information indeed do better through CAE (content provided via the Internet) than those interested in gaining concrete knowledge, who perform better via CBE (the use of CD-ROM). However, this comparison started to become blurred when it incorporated links from contents on CD-ROM to be anchored to other web-based material. This example shows how making changes to a small part of the design of an e-learning system (anchoring parts of content material to other web-based resources) could reflect on the acceptance of an e-learning system by its users.

Furthermore, in addition to the study of different types of e-learning systems, as mentioned earlier, any LMS, from a pedagogical perspective, presents learners with – or guides learners towards – learning content material; however, the selection of that content material needs to be controlled by a tutor, the machine, or the learner's own approach. For example, in a computer-aided learning system or otherwise named web-based CAE (Computer Aided Education) system, which is a guided and interactive learning system which makes extensive use of non-sequential hypertext (Kirschner & Paas, 2001; Retails & Skordalakis, 2001; Torkazadeh & Van Dyke, 2002; Shana Z.A. 2009), the teacher leads the pace of CAE and the learning is more collaborative than with CBE (Computer Based Education). In the latter, all class interaction must be done through the use of a personalised computer, whereas in CAE the computer is used as part of the facilitation of education in the class. Students interact with each



other and with the instructor using discussion threads and often with interactive chat sessions.

### **Intelligent Computer Aided Learning Systems**

Alongside the exploration of different types of e-learning systems, Artificial Intelligence-based type of Computer-Aided Learning (AI-based type of CAL) systems should be discussed, as this topic will clarify the understanding of the concept of personalisation of e-learning systems.

In computer science, Artificial Intelligence (AI) refers to a category of scientific research that studies the abilities of machines to learn by themselves by preparing sets of codes and programs suitable for computers and to mimic a human-like approach to thinking. Examples are: speech recognition, image understanding and recognition, synthesising, analysing and decision making (Burns-Capps, 1988). Successful implementation of an artificial intelligent system is always a very difficult engineering problem, because traditional and typical computers do not have any sign of intelligence. Additionally, attempts have been made to study Distributed Intelligent Systems (DIS) and because of the internet standardisation, designers have selected this as the base platform for the research. For instance, Brusilovski (Brusilovski et al., 1997) reported successful implementation of a distributed intelligent system on the Web, at the time. The system was adaptive in some ways, it could customise student features and was implemented in calculus teaching.

In addition to the above arguments, Monadjemi and Ahmadi (Monadjemi A, Ahmadi A, 2002) mention that the main issue in the design and development of any e-learning system would not only be related to the core design of existing ELSs but would

originate from the use of related external tools. They presented a set of points as the base of the brainstorming phase on designing any ELSs for configuring the external effects listed below:

- ***Declining teacher's role*** – the idea of replacing a good teacher with an artificial intelligent system won't be accepted, but it could complement other learning resources. In that view, blended e-learning systems would fit into this proposal. (Blended e-learning is an integrated online learning environment of different methods and technologies based on different learning theories to increase the effectiveness of the delivery of knowledge, in the form of e-learning, e-communication, e-collaboration etc. combined with face-to-face classroom interactions (Lam, S., 2008).)
- ***Unattainable expensive software*** – this limitation creates a wider gap between the use of the usual online platforms and specialised, sophisticated and expensive software, which not many educational centres are able to use. However, if it proves that it could provide scientifically-based confirmed factors that an adaptive e-learning system will support a learner's learning style and can increase his/her learning performance, the expensiveness of the software will not be counted towards the worthiness of its design and development. This is another factor which this study discusses: the possibility of a fundamental design and development of a whole new ELS for the purpose of studying the relationship between an individual's learning style and his/her learning performance.
- ***Losing Academic Transitions*** – with three thousand years of educational history, there will not be any direct transition of teachers' behaviour towards students; a machine would never be able to replace that. The main reason is the unarticulated

type of tacit knowledge (see Appendix 9). The discussion intends to explore the current aim of this research (section 1.4) by understanding the relationship between an individual's learning style and the personalised form of knowledge to be gained through the strategic knowledge concealed within.

Furthermore, intelligent CAL is not the whole future of the education, although, as time goes by, computer-aided learning systems will become more essential, more experienced and more consequential.

In the process of understanding the aims and objectives of this research, another question can explore the topic further: "What new era could an online learning system bring to the knowledge transfer environment?"

As known, knowledge is something invaluable on its own, but in the mind of its holder. On the other hand there is no point in holding knowledge when it can't be processed or be productive. These are the two main reasons for the need to transfer knowledge from one mind to another. The modality of transferring knowledge and sharing it is known as education. In that respect the requirements of the need for education would support having a specific form of medium which would give reassurance of knowledge transferring, such as running quizzes, exams and assignments at the end of its delivery. At this point the education form of knowledge transfer would be different from other forms of knowledge which are transferred by any usual knowledge management systems.

Therefore, to investigate the study of e-learning systems further, it is necessary to learn more about the characteristics of an online learning environment.

### **2.2.5 Advantages and Disadvantages of Online Learning**

Despite the fact that there are a large number of benefits that have been cited by researchers and instructional designers about the use of online learning systems, the fundamental benefit remains the same, which is “the sole purpose of any online learning system is to develop the learner’s knowledge and understanding”. In addition, researchers like Parise [Parise P. 1998] identify a few points to consider as part of knowledge delivery: learners could choose their own developing (learning) environment such as being in their own private room, working at their own pace and to their own time schedule. Learners do not need to be on campus to receive lessons, to improve their writing skills, or to be evaluated on the basis of class participation any more, as the above actions were required when reassurance was needed in the confirmation of the delivery of knowledge. However, via online learning, instructional designers will have designed the process of interaction in such a way that reassurance could be confirmed through methods like tracking a learner’s activities to confirm his/her involvement in the process of interaction with the required knowledge.

The downside of having an e-learning system is for instructors who need to develop course materials that are up to date, easy and fast to revise in today’s ever-changing world of knowledge delivery. Even though the advantages of the web and the latest in digital production development such as video camera technology support the development of learning materials, there still is not enough of a cognitive view that is accessible to both sides (instructors and learners). For example, in synchronous communication, each side only has a two-dimensional view of the other and they have no view of body language in a 3D environment, so both sides of the system (learners and instructors) must possess good writing skills (which include typing with good

grammar). In addition, learners must have a good degree of initiative and self-motivation to understand instructions given by the tutor and must continue to gain knowledge on their own. Another example would be class discussions, which are a focal point of most classes and would be considered one of the key benefits of a pedagogical approach. Though collaboration-based types of ELS exist, they still can't provide that sense of individualism through a system such as the ability to include the characteristics of self-paced learning of learners. It is usually difficult to arrange such discussion sessions in a timely manner. These contents will be discussed thoroughly later in section 2.6.1.

### **2.2.6 Conclusion of this section**

This section has provided an analysis on learning systems with specific attention to e-learning environments and why e-learning systems could be the solution for the use of knowledge transferring mechanisms; and how the existing design of e-learning systems could be expanded by the support of the concept of adaptation. In that respect, comparisons were made between CBE (a slow-to-update e-learning environment), CAL and AI-based CAL systems which are types of non-adaptive ELS despite having minds of their own. If CAL systems are designed correctly to adapt to an individual's learning needs, it would certainly be more efficient in terms of its user's learning curve. Researchers are continuously in the process of finding new methods and improving the existing involvement of pedagogical (teacher-centred), andragogical and heutagogical (learner-centred) approaches on the design and development of e-learning systems. As a result, the gap of interaction between both learner and computer will be smaller and much closer to the individual's learning

style, which means actions taken towards adapting the knowledge will have been more compatible, leading to an increase in the efficiency and performance of the knowledge transfer. The following sections will approach that medium by understanding learner-centred requirements and the concepts of self-organisation with the involvement of the concept of adaptivity into existing e-learning systems.

## ***2.3 Adaptivity of Learning and E-Learning Systems***

In this section the concept of adaptivity and its differences to adaptability will be studied; it will also examine what the role of publicly known personalisation of e-learning system is in this respect. The necessity of adaptation for an e-learning system and the reasons for having an adaptable e-learning system will be examined.

### **2.3.1 Adaptive Systems Processes**

The following section is an analysis of adaptive systems, which will be the framework for further study towards developing an adaptive e-learning system. As mentioned earlier, the point of having an A<sub>v</sub>ELS is not only to design and develop an e-learning system which interacts solely on the basis of the learner's behaviour, responds in the manner of a good colleague and is user-friendly; it should also act like a real lecturer with sufficient knowledge of instructional design and teaching methods.

#### **Adaptive learning systems**

An adaptive system is a process that possesses itself in, that retries different methods of communication in new conditions by undertaking varieties of small packages of structured sub-systems, so that it can gain the ability to convert the new environment into its built structure (Heylighen, F. (2003). This method of changing the new

environment to a form which is acceptable to its original development system is known as the self-organisation method. By understanding the definition of adaptivity, and recognising key points of involvement of the characteristics of adaptivity in an e-learning system, it is possible to have a system which could mimic the learner's method of learning so to present him/her with adapted content material.

### **Is having an adaptive e-learning system necessary?**

As traditional classes usually attempt to adapt to a learner's learning style, especially in a one-to-one session, in e-learning environments, they also attempt to accommodate many different learning styles into teaching, and people are then able to choose a learning method which is most effective for them. Depending on their learning style, they would learn either via a visual or verbal process, or they might take an analytical or experimental approach to interacting with their course materials. The personality of the learners is also an important subject in this context; for example, if they are 'morning people' or evening people', sprinters or plodders, extrovert or introverts [W. Horton 2000].

By considering the above points during the instructional design phase of developing any online learning system, learners could be reassured of having flexibility and freedom of learning through an e-learning system.

### **Complex Adaptive Pedagogy (CAP)**

As part of the analysis of adaptive learning systems, Lofman (Lofman, B. 2002) presents three methods to follow for designing and developing a complex adaptive pedagogy. They are: (i) The instructor must be sufficiently flexible to give up considerable control; (ii) Students must be adaptive and willing to cope with

ambiguity; (iii) The broader instructor-student relationship itself must be transformed for these mutual adaptive capabilities to be unleashed in this untraditional teaching-learning environment. He criticises the teaching and learning methods of today, and to make his point he mentions the lack of methods which instructional designers utilise to pursue the needs of learners in order for them to survive on a daily interaction with information without guidance, as it is not enough. In other words, the current methods of guidance are not fully developed to support direct learners in such a way that learners would be reassured of having the necessary knowledge and skills to fully comprehend their interaction with information on a daily basis.

On one side of the coin, learning methods have continuously been adapted to solve the problems of everyday life over the centuries, and learners should have the vote of confidence that they can carry on within today's ever-changing world of knowledge and communication. But the questions here should be: "How much reassurance do these methods of learning offer regarding their ability to facilitate changes in knowledge building over a period of time? Can existing methods of learning support self-directed learning while learners pass through a cloud of knowledge?" In that respect, Lofman (2002) clarifies these shortcomings on the incompleteness of the part of knowledge where instructional designers basically are not aware of and – at the same time – are responsible for devising new learning methods. These perceptions would certainly produce an incomplete framework for new learning methods.

Learners do need to be motivated and engaged in finding other unforeseen methods of gaining knowledge for themselves, although they would rather have the reassurance of a road map to navigate through daily information. However, continuous changes and innovations in technology and communications could change the structure of



teaching and learning to facilitate such unforeseen circumstances. For further studies on existing systems that are adaptive in nature, the reader is referred to Appendix 8.

### **2.3.2 Differences between adaptable and adaptive systems**

While investigating the concept of adaptation further, Kinshuk and Russell (2002) have categorised existing learning systems into two types of system: “Adaptable” and “Adaptive”. In an adaptable system (which is mostly known as a “Personalised System”, but not in this research) users can modify their settings in the system’s environment. As its name indicates, adaptability (known as personalisation) is a process in which a user controls the system. But in the adaptive model, the system is in control [Katemo, H. 2003].

Following the above definitions, the main dissimilarity of adaptive types of systems is the concept of being in control of gathering information on learners whether by the system itself or by its users (learners); this means the task of “learning about an individual’s behaviour and learning style” should be given to the system and the system itself would be responsible for gaining that information; unlike an adaptable ELS which requires the setting up of predefined preferences on the system by its user.

As discussed in section 2.2.3, this is the measure of control which specifies different types of e-learning systems. If the control is given to the system and the system starts to learn about the learner’s learning style, then the system will be called an adaptive e-learning system, since the system wants to adapt to the learner’s learning style so as to guide him/her through the instructed knowledge. On the other hand, if the learner starts to make changes to his/her learning environment and tells the system about his/her method of learning, then it is called an adaptable e-learning system, if we presume of course that the learner is aware of his/her learning style. In this case it

should also be clear that as the system is in control in an adaptive e-learning environment, the predefined content material provided by an instructor should be available somewhere in a database where the system can start providing access to the user based on the profile the system has gathered of the learner's learning preferences. Alternatively, in an adaptable e-learning system, the system places predefined content material in access of the user and because the learner is in control of his/her learning, the learner can go through that content material in the sense that one of two cases of instructional methods (andragogy or heutagogy) have been exercised. The main difference here is that in both methods, an element of pedagogy is present, because after all the reading materials have been prepared by someone else, and in terms of education it doesn't make sense to take all students through a period of self-motivated research while they are already taking part in the research and intend to learn about a subject. On the other hand, students in primary education do not have an understanding of the cognitivistic approach towards their learning nor are they equipped with sufficient knowledge and skills to use a heutagogic method to gain further knowledge.

## ***2.4 Knowledge management and personalisation of e-learning systems***

As human beings require methods for acquiring new skills and methods for survival, they have continued to try and make a better place for themselves over time, and have continuously passed on their hard earned and learned skills to the next generation (to

their children, to their children's children and so on), from hunting foods to making fire [Erren et al. 2007].

For generations, one of best methods of learning has been observation and getting involved with the practicality of jobs. However, it was known that the process of learning and gaining a new skill demands a tremendous amount of hard work and time to make the learner proficient in the job.

In that respect, defining the boundaries of knowledge and its development were counted as a major factor in this picture of the growth of human understanding of life. The transferring of knowledge from one mind to another in a variety of formats has been a continuous theme since the beginning of the history of mankind, while the issue has been debated thoroughly from the beginning of something called Education. Teaching methods have been used for generations, although the end result is always expected to be the delivery of knowledge from teacher to student and in the end, learning occurs. In this study, the similarities and differences between both teaching and learning environments are explored. Continuation of this research – as provided in section 1.4 – is based on studying which environments are suitable for teaching and learning, how a student or a learner can receive knowledge, how the delivery of knowledge can be confirmed and whether learning occurs.

### **Personalisation of e-learning systems from the knowledge management perspective**

The definition of knowledge comes with making sense of existing collections of information in the form of understanding their purposes, use and the process of creating new information. The pattern in which information is created, processed, stored and re-created again is what makes knowledge (Nonaka, 1991; Nonaka and Takeuchi, 1995; Haberberg, A. & Rieple, A., 2008, pg. 408-409). Meanwhile,

knowledge, like any other entities, would require management to apply it in day-to-day life. It requires the creation of an environment in which information can be passed along to the right person, at the right time, and in a suitable format with insights and experiences. A set of processes that creates, captures, stores, maintains and disseminates a firm's knowledge (Laudon, and Laudon, 2007-pg., 434). Furthermore, strategic knowledge (as a type of knowledge) is the core component in producing any option from any situation, and learners would then choose any of those options based on their method of decision making (Appendix 9); or in other words, an individual's unique decision making method which is the key to an individual's unique learning style is a determining factor when approaching a knowledge concept. This individually based unique method establishes a set of roles and guidance when it comes to approaching and directing those concepts. The interaction with those concepts will be guided by a set of roles which are unique to the learner's learning style. It is worth mentioning that the relationship between learning styles and the strategic knowledge establishes the groundwork for the concept of personalisation of any learning management systems (LMS) which in turn gives the building block for a personalised e-learning system. For further discussion, the reader is directed to Appendix 9.

On the other hand, to seek the performance of a type of an e-learning system in terms of measuring learner's learning performance, it is the measure of control given to either learner or the system which is the determinant factor for measuring the performance. Besides, one of the instruments of measurement is known as assessment methods. As the approach of the Read-Memorise-Pass the quiz is not enough to completely confirm that learners have understood the materials presented to them (despite the fact that this method has been practised for centuries), it is necessary to

seek the origin of learning and assessment philosophy to find a preferred method and the way mentioned earlier. Therefore, based on types of knowledge known as i) basic knowledge, ii) procedural knowledge, and iii) conceptual knowledge (Shute, Valerie and Towle, 2003), three methods of assessments are developed for the purpose of design and development of creating a framework for any future design of assessment questions.

## ***2.5 Individual's Learning Factors***

In this section, factors influencing an individual's learning will be discussed. Psychological factors for a learner-centred knowledge-transferring environment, individuals' learning preferences, physiological learning factors, the relationship between time spent on learning materials and the performance of the learner, and learners' multiple intelligences will be discussed.

### **2.5.1 Learner-centred psychological principles**

This section will attempt to put a spotlight on the vast subject which is the psychology of a learner and approaches to gaining knowledge in the form of information to depict a processed form of structured-based knowledge, which means the study of how a learner's psychological factors could affect the production of knowledge from information. In this section, the effects of a learning environment will be studied where the learner him/herself is in control of his/her learning methodology.

On the basis of the analysis on the issue of learner-centred psychological factors for setting a benchmark on recognising learning needs, there is a shortened version of a report done by the Work Group of the American Psychological Association's Board of

Educational Affairs in 1997 [LCPP, 1997]. It sets out 14 rules as a framework to categorise learner-centred class environments to create an atmosphere where the psychological side of the learner is the focus.

These rules focus on psychological factors that are primarily internal to and under the control of the learner, rather than conditioned habits or physiological factors. However, the principles also attempt to acknowledge the external environment or contextual factors that interact with these internal factors. They are categorised into four groups with which their relationships with the current system under the study are explained. They are: a) cognitive and metacognitive factors; ii) motivational and affective factors; iii) developmental and social factors and iv) individual differences.

### **Cognitive and Metacognitive Factors:**

1. **Nature of the learning process:** On the basis of meaningful information, construction and experience of an intentionally built complex subject that matters, learning would be in the most effective form of acceptance by the learner. This psychological factor would show the important need to have a knowledge transfer environment in the form of a learning environment.
2. **Goals of the learning process:** A successful learner with support and proper instructional guidance will be able to present a coherent and meaningful representation of knowledge over time. This would be the main goal of directing a learner's interaction with an e-learning system towards a specific goal known as learning objectives.
3. **Construction of knowledge:** A learner, who is successful in the construction of knowledge, will be able to link newly achieved information with existing

knowledge in meaningful ways. As such, throughout the involvement of a learner with the system, there are sets of assessments which are designed to confirm the progress of an individual's learning by the method of construction of knowledge.

4. **Strategic thinking:** A successful learner can create a useful reasoning strategy and thinking towards the achievement of complex learning goals. A learner, by using e-learning systems, would have a clear idea of what to expect and how to achieve it.
5. **Thinking about thinking:** By selecting and monitoring mental operations towards creative and critical thinking, higher order strategies can be achieved. This is part of the system and the only way to measure it would be through different methods of assessment for different types of content.
6. **Context of learning:** Educational environmental factors, including culture, technology and instructional practices influence learning. Teachers, by preparing and presenting knowledge concepts to learners, have a major influence in the development of learning environments.

**Motivational and Affective Factors:**

7. **Motivational and emotional influences on learning:** The level of achieved knowledge by a learner depends on and is influenced by a learner's motivation, and in turn, motivation to learn is influenced by the learner's emotional states, beliefs, interests, goals and habits of thinking. By giving continuous feedback to a learner, s/he would be encouraged to continue with

the process, though it needs to be mentioned that the report-giving tool would need to be available in case the learner requires it.

8. **Intrinsic motivation to learn:** Factors such as learners' creativity, higher order thinking, and natural curiosity all contribute to the motivation to learn. The core psychological feature of motivation is stimulation by the most original and difficult tasks that are relevant to personal interests and provide personal choice and control.
9. **Effects of motivation on effort:** Extensive and extended learner effort and guided practice is required to achieve complex knowledge and skills. Strategic effort alongside persistency over time is needed as a major indicator for the motivation to learn.

#### **Developmental and Social Factors:**

10. **Developmental influences on learning:** By building a learner's knowledge and requirements for further development, the effectiveness of physical, intellectual, emotional, and social domains must be taken into account.
11. **Social influences on learning:** One of the major factors in learning enhancement is when a learner starts to interact and to collaborate with others on an instructional task, as this is influenced by social interactions, interpersonal relation and communication with others.

#### **Individual Differences:**

12. **Individual differences in learning:** Each individual learner has his/her own talent, capabilities, different approaches and strategies for learning. These could be counted as functions of previous experience and personality, which



will be studied by investigating the relationship between individuals' learning styles and the knowledge gained through this process.

13. **Learning and diversity:** Social backgrounds, socioeconomic status, cultural (effects of race, gender etc) beliefs, ethnicity and linguistic diversity are a few of the factors that could affect learning. Despite the above-mentioned points, in this study it is considered that no social differences between learners exist, and it is the responsibility of the learner to control and adapt to the new environment for his/her learning process.

14. **Standards and assessment:** Using a standard set of assessments to assess an individual's learning performance and general learning progress can help the teacher by providing continuous feedback on the progress of a learner including his/her skills, motivational enhancement and self-directed learning abilities.

## 2.5.2 Learning Preferences

According to Dunn and Dunn (1992, 1993), students have learning style preferences.

They have listed 21 variables that affect learning in five categories:

- **Environmental:** sound, light, temperature, design
- **Emotional:** motivation, persistence, responsibility, structure
- **Sociological:** learning alone, in pairs, with peers, with an adult
- **Physiological:** time of day, mobility, food or liquid, intake, auditory, visual, tactual, kinaesthetic

- **Psychological:** right/left brain, impulse/reflective, global/analytic

It is worth mentioning that as Hwang & Wang (2004) have studied other characteristics of a learner's personality and their relationship with an individual's learning styles, they have come across other types of related issues such as: ambiguity tolerance, anxiety, field dependence / independence, active / passive learning, locus of control and self-efficiency, to name a few; however these are outside of the scope of this study. The reason for not selecting the above mentioned learners' characteristics, is the level of complexity that this would introduce into the system under study and time it would take to address all these issues would be beyond the scope of what could be achieved in a PhD. There are many examples of such characteristics for example, the ergonomics of the learning environment (either room or an open space) which would be too difficult to control.

### **2.5.3 Current traditional learning methodologies in relation to the duration of learning**

One of the main concerns about traditional teaching classes is the inability of most students to effectively listen over a period of time, regardless of the lecturer's teaching skill (Bonwell C.C., Eison J.A., 1991 and Chism et al., 1990; Appendix 16). In that respect, Stuart (Stuart J., Rutherford R.J.D., 1978) mentions an important understanding gained through his research more than a decade sooner that it is the quality of the learned material which counts when students have to concentrate for a long time in a class. The amount of material absorbed tends to be high at the beginning of the lecture for 10 to 15 minutes and then it falls steadily thereafter for

another 25 to 30 minutes. This is a good reason to make the duration of classes between 25 to 30 minutes rather than 50 minutes.

Generally, the classic mistake teachers used to make in traditional classes, and a percentage of them still do, was/is the way they perceive each learner's learning methodology. The mistake is to think that all students have the same method of learning and teachers who assume this present their classes mostly in the form of oral lectures, at the same pace and without any interaction with the students [Chism et al., 1985 and Johnson et al., 1992; Lee, L.L. and Zailani, S. 2010). In addition, such lecturers believe that all students have good auditory learning skills, good note-taking abilities (if not, the skill could be gained), high memory capacity and are adept at handling information processing overload (Johnson et al., 1992). As many student surveys have confirmed, most lecturing classes involved a passive approach to learning that is too uniformly didactic and largely out of the students' control (Knapper D.J., Cropley A.J., 1985 and Lindquist L., 1978; McCarry, N.E. and Mazur, J.M. 2008). Lindquist (1978) gives examples of the wasted potential of traditional classes through activities, such as spending a lot of time on note-taking and spending too much study time on memorising rather than doing other activities, such as analysis, application, synthesis, and evaluation. Bligh (1972) found that there is much evidence that lectures are less popular than other methods of instruction. Costin (1972), in a review of multidisciplinary research (for example biological sciences), compared lectures with discussions, student-centred projects, reading, and self-instruction, and made the following conclusions: in terms of gaining information lectures are usually similar to the context of discussions or student-centred learning environments such as student projects, although discussion sessions are probably

more effective at teaching cognitive skills, such as interpreting knowledge and solving problems.

Discussion sessions and student-centred projects are more effective at helping students to retain information beyond the termination of a course. As for lectures vs. reading and self-instruction, there is no clear-cut superiority of any one method over the other. If any advantage exists, it may be in the direction of self-instruction.

#### **2.5.4 Conclusion on Individuals' Learning Factors**

By illustrating a variety of factors involved in a learner's learning environment, issues regarding psychological factors such as cognitive and metacognitive factors and individual differences were studied. Visual, auditory, tactual and kinaesthetic learning preferences in the physiological category of learning factors have been used as the principles of the framework for designing AAPELS. In addition to that, studying the relationship between the time spent on learning materials and the performance of a learner is another factor which sets a framework for any possible research.

#### ***2.6 Issues in designing an adaptive e-learning system***

In this section, issues related to learning environment, learning systems, e-learning systems and the adaptivity of such systems are discussed in this section is concluded by a survey on existing UK's higher education institutions and how it affects our understanding of adaptive and personalised e-learning systems.

### **2.6.1 Issues in Designing a Learning System**

There have been many types of learning systems used, such as traditional teacher-student learning environments, for many generations. Hence it is necessary to discuss issues involved with the process of designing learning systems, which are: i) understanding learning environments, and ii) collaborative learning environments, in terms of the measure of control given to learners.

#### **Learning environment**

A learning environment is an environment where the main goal must be the delivery of knowledge from one mind to another by any means possible with additional supplementary feeds on the state of mind where the application of gained knowledge must be adequate in its conversion to have a practical solution on real life problems (Berg, D., 2009).

The research indicates (Devaney L., 2010) that an overwhelming number of students have shown an increase in their learning activities while being involved in a collaborative learning environment. Furthermore, as the concept of collaboration directly involves the concept of group-based activities, and humans by nature are a social type of creature with his/her own mind set, further investigation of this concept provides better understanding of the learning systems used for the delivery of the knowledge and the types of learning systems.

#### **Design of a collaborative learning environment**

The main concern of a collaborative learning environment is the willingness of learners to contribute their time and effort in the constructive process of their

knowledge. Madden, Slavin and Kumar (Slavin1978; Madden & Slavin 1983; Kumar 2002) have already confirmed that learners in team-based classes felt that their teammates want them to learn. In relation to designing a learning system in a collaborative environment, there are a few different approaches that could be learned from the environment shared between peers, tutor and machine, as Kumar (2002) has described. This, followed by a well-restricted environment by Chi [Chi et al. 1989], led McCalla (1990) to develop a set of roles as a model to set a collaborative learning environment. (Appendix 18)

## **2.6.2 Preliminary analysis of designing an adaptive e-learning system**

### **Existing adaptive e-learning systems**

Throughout the history of online learning, the main concern was, and still is, the use of different methods for developing ELSs. Hence, a conducted preliminary survey of 195 UK educational institutions (October – December 2004) gave an indication of the types of e-learning systems used in those institutions (HERO, 2008; ELISA, 2005; and Mustafa, A. 2004).

The main objective of this research is to learn about the key factors of the various types of e-learning systems (Appendix 1) and their effects on learners' learning performance. The gathered data were stored in a database built for this purpose (Figure 2 and Figure 3).

The basis of this research was to search through each institution's website, their search engines and their library's website to find materials on their use of an e-learning system, as it is the best medium for institutions to present their ideas and

services. On many occasions a link was followed to many other web pages within their related departments and their published web pages. Individual lecturers and staff websites, related conferences' reports and many other links have been followed for this reason; so any chance of getting any information related to their services on e-learning systems (not precisely distance learning) and ideas of establishing their system was taken. A few departments (school offices) of universities were directly contacted (by telephone or by email) to gain more in-depth information about their use of e-learning systems, if any.

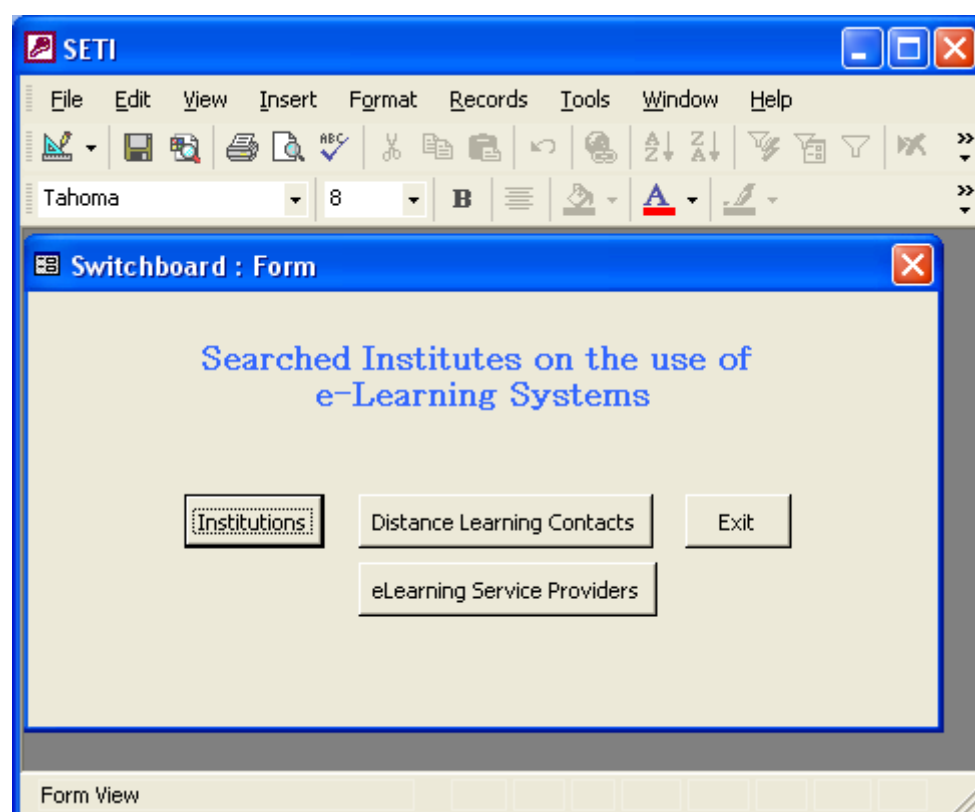


Figure 2: Screen capture of searched institutes on the use of e-learning systems' switchboard.

**Searched Institutes provide e-Learning Systems**

Institute ID:  Institution Uses eLearning:  Institution Uses CBT:   
 Institution Name:  Institution Uses WBT:

**Multimedia Presentation**

Institution Uses Online Content Materials:

Institution Uses Animation:

Institution Uses Video Senario:

Institution Uses Video Conference:

Institution Uses Course Buletin Board:

**Interactive**

Institution Uses Interactive Static:

Institution Uses Interactive Live:

Institution Uses Email:

Institution Uses Discussion Forum:

Institution Uses Chatroom:

Institution Uses Online Tutorial:

Institution Uses Adaptive eLearning System:

Link to Institution:  University of Greenwich

Notes on Institution:

List of Institutes

- American InterContinental University - London
- Anglia Polytechnic University
- Arts Institute at Bourne-mouth
- Aston University
- Bath Spa University College
- Bell College
- Birkbeck, University of London
- Birmingham College of Food, Tourism and Creativ
- Birmingham School of Speech and Drama
- Bishop Grosseteste College
- Bolton Institute of Higher Education

| Table of E-Learning System Provider(s): |                      |   |               |
|---|----------------------|---|---------------|
| ELSP ID                                 | ELSP Name            | Link to ELSP  | Notes on ELSP |
| ▶ WebCT                                 | WebCT                | <a href="http://www.webct.com">http://www.webct.com</a>             |               |
| Lotus Learn                             | Lotus Learning Space | <a href="http://www.lotus.com/produ">http://www.lotus.com/produ</a> |               |
| *                                       |                      |   |               |

Record: 1 of 2  
Record: 75 of 195  
Form View

**Figure 3: Screen capture of the form used for entering information on the type of ELS used at each higher educational institution.**

The outcome of the preliminary analysis of searched data on universities and higher educational institutions (gathered in 2004) is presented in Table 1. Data were collected based on the websites of individual institutions and whatever tools had been used as the principal means of using the e-learning system.



|   | Number of Edu. Institutions | Ratio compared to the total number of Institutions searched for |
|---|-----------------------------|---|
| Total No. of inst. under research           | 195                         | 100%  |
| No. of inst. use eLearning Systems *        | 90                          | 46%   |
| No. of inst. use particular LMS             | 56                          | 29%   |
| No. of inst. use Adaptive eLearning Systems | 0                           | 0%  |
| No. of inst. used WebCT                     | 29                          | 15%   |
| No. of inst. used BB                        | 16                          | 8%  |

*\* Any electronically based method of technology used for the purpose of communication.*

**Table 1: Findings from data stored on universities' use of e-learning systems**

### **Discussion and conclusion of this section**

The preliminary survey (Table 1) showed that there was not a single adaptive e-learning system used in higher educational institutions in UK – except an intelligent tutor type of e-learning system which was used merely as research and/or course supplement (HERO, 2008; Intelligent Tutor, 2004; ELISA, 2005; and Mustafa, A. 2004). This raised great interest in this project and its potential, and it was deemed necessary to find out more about this area of adaptivity of e-learning systems. To proceed further, re-examining the development process of an ELS would be a necessary step.

### **2.7 Conclusion of this chapter**

Through out this chapter, concepts and philosophies of learning were studied. The role of learning environments and learners' learning preferences presented an understanding of their impact on learners' learning performance, which subsequently shows their dependency on the concept of a measure of control given to either the

learner or the machine. The reflection on these concepts provided enough reasoning to rethink the aims and objectives of this research. Furthermore, from different perspective, it can be argued that by reviewing the existing course materials available on TeachMat (an existing Learning Content Management System used for storing, delivering and presenting course materials for a variety of programs in the School of Computing and Mathematical Science at the University of Greenwich, <http://www.cms.gre.ac.uk/>) and searching for possibilities on developing an ELS by the use of existing and available technologies, this research intends to learn the reasons “why AvELS is not publicly practised in UK’s educational institutions?” Different tools (ELSs) were accessed from different sources – found as samples for this research – to sketch the best possible design to develop an adaptive e-learning system. On the other hand, based on the phases of i) the complexity of processes of adaptive systems (2.3); ii) the differences between concepts of adaptivity, adaptability and personalisation of e-learning systems (section 2.3); and iii) the complexity of the design (appendix 35 of the production log) and the development of adaptive ELSs, it was decided that at this stage of the research it is cost effective (in terms of time and effort), and more interesting in terms of the consideration of the effects of learner control of the learning environment, to focus the investigation on the impact of adaptable and personalised e-learning systems on learner’s learning performance. Therefore a refined version of the hypothesis is presented in the next section to further the investigation on the current study’s aims and objectives.

## **2.8 Refining the hypothesis and methodology based on new findings**

Based on the analysis above and the new understanding of the concept of personalisation of e-learning systems, a refined version of the hypothesis seemed necessary; it is developed as follows:

**Refined hypothesis:** “That learners’ learning performance increases more while interacting with adaptable e-learning systems than with personalised e-learning systems.”

### **Refined activities:**

Since the hypothesis has been refined, so must the roadmap for the methodology to find the aims and objectives. The phases are as follows:

- i. Investigation into the possibility of analysis, design and development of an adaptable and personalised e-learning system, which aims at measuring learners’ learning performance.
- ii. Measuring the effectiveness of adaptable vs. personalised e-learning systems on learners’ learning performance, within categories of knowledge assessment methods.
- iii. The newly designed and developed adaptable and personalised e-learning system requires newly structured and developed content materials, so to be compatible with the newly designed and developed e-learning system.
- iv. Developing the experimental and evaluation methods as a road map towards analysing learners’ activities and measuring their learning performance.

## **Chapter 3      Issues in designing an Adaptable, Adaptive and/or Personalised E-Learning System**

### **3.1 Overview**

In this chapter existing methodologies and design of types of e-learning system, which would be able to deliver learning-preference-based content materials are discussed. The physiological learning preferences and its relation to the type of designing assessment questions is discussed, which further on leads to the understanding of the concept of decision maker unit, feedback-based control system and varieties of possible types of e-learning systems.

It is important to mention that, although the rest of the study has been developed for the purpose of finding the effectiveness of adaptable vs. personalised e-learning systems on learners' learning performance, for the purpose of covering all the bases and possible future extended research, issues related to an adaptive e-learning system have been investigated side by side of the above-mentioned systems. Hence, AAPELS ( $A_VA_LPELS$ ) stands for adaptive, adaptable and personalised e-learning systems.

## **3.2 A Review and Analysis of Traditional and Current E-Learning Models**

### **Dick and Carey's model for ELS**

With continuous changes and updates to the process of design and development of e-learning systems, selecting a suitable framework and model to follow was a challenge. However, as most designs had a similar idea behind all their design stages, the selection was narrowed down to a few options. As the basic idea behind any e-learning system is to provide content material through a web-based system, where a learner could get access to content material whenever and wherever s/he liked with synchronous/asynchronous live support, the model developed by Stone & Koskinen (2002), which is an upgraded version of Dick and Carey's (1990) traditional e-learning model, was selected. It basically took the design and development of an ELS project through a loop known as the System Development Life Cycle (SDLC) and was mostly concerned with the analysis phase of instructional design, which in turn is the most significant stage of any SDLC (see Figure 4).

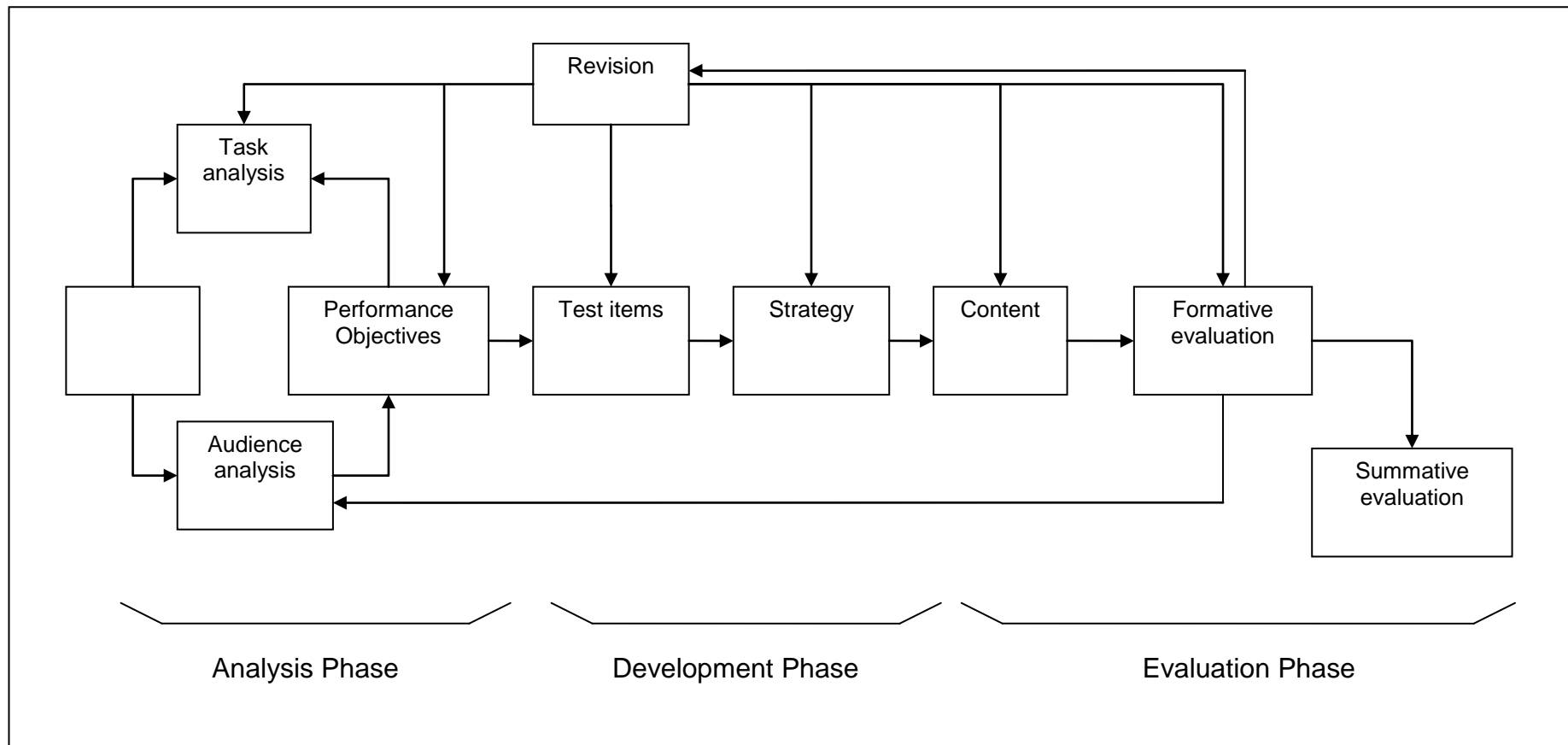


Figure 4: A traditional instructional design model developed by Dick and Carey, 1990.

The model was developed further and changes were made to its SDLC model. The new model developed by Stone & Koskinen (2002), which is an upgraded version of Dick and Carey's model for e-learning development, is shown in Figure 5. The original model will not be discussed in depth here because it is not the main concern of this project, since the key point of this research as stated in section 2.8 (revised hypothesis) is to design an online learning environment where the learners' learning performance could be measured on the basis of learning styles and measures of control.

### **The current Stone & Koskinen model for ELS**

An e-learning development model begins, like the traditional model (Dick and Carey, 1990), with a thoughtful analysis of current and desired conditions. As in the traditional model, the analysis phase consists of a need and performance analysis, an audience analysis, and a task analysis (Figure 4). In the current e-learning model, besides all the above factors, a technical analysis and a cost-benefit analysis also needed to be performed to ensure that the subsequent strategic plan takes into account the current and desired technical and financial conditions. Figure 5 demonstrates the steps with the currently practiced model to develop an e-learning system (Stone and Koskinen, 2002).

The emphasis of this project is on section two of the process "Strategic Planning" and sub-section three identified by "Instructional design" (Figure 5).

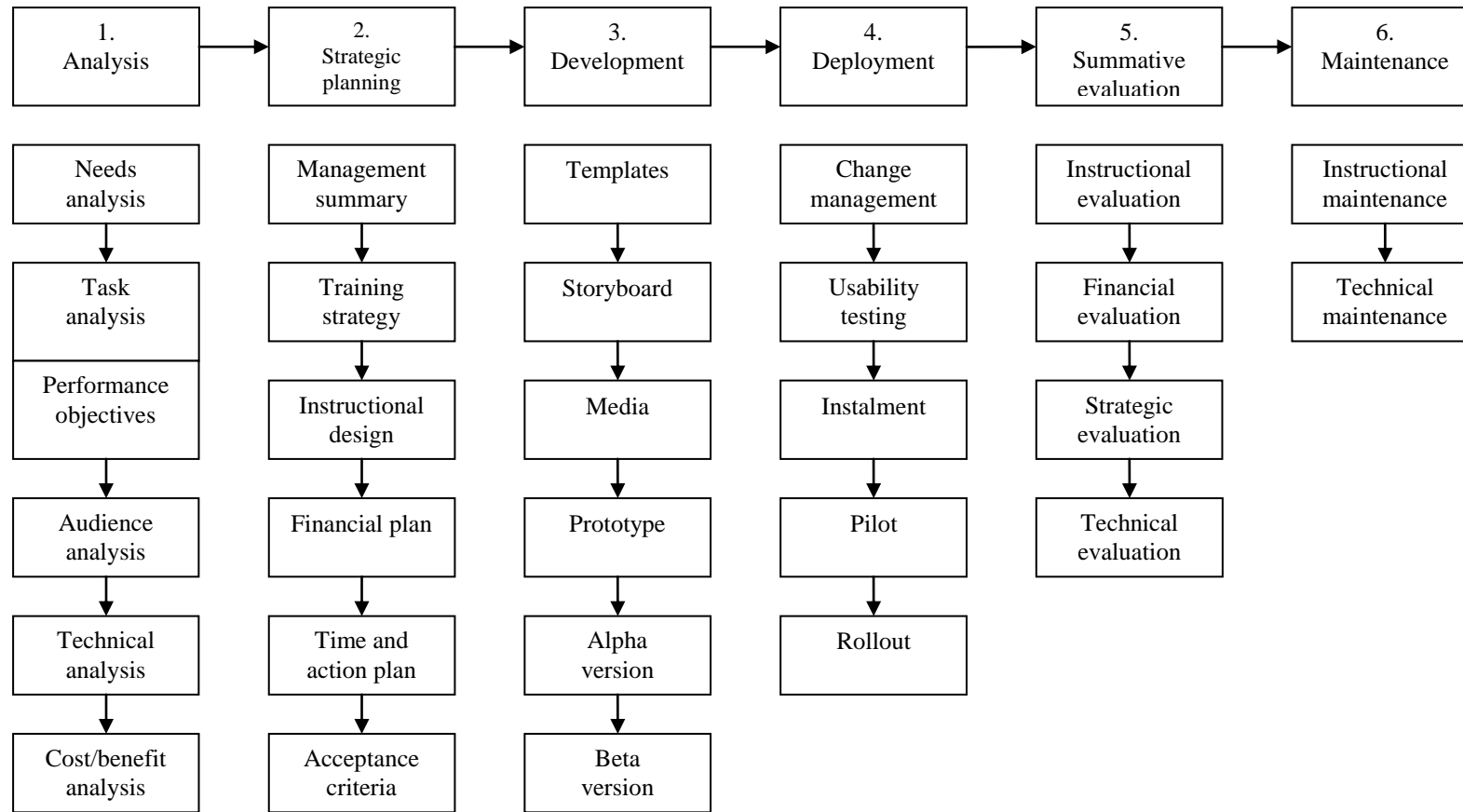


Figure 5: A model for developing an e-learning system (Stone and Koskinen, 2002)



The main concern of an adaptable and personalised e-learning system would be to keep track of students' activities and to measure the level of learners' learning performance. The instructional design system provides a method for teaching a subject (Figure 5), which means instructional designers must be aware of the learners' needs and their individual learning style, so that the learning materials given to learners are as comprehensible as possible. It is here that the adaptability of a system plays an important role while developing instructional design materials [Stone and Koskinen, 2002].

The next step would be to learn about physiological learning factors (2.5.2) which could form a basis for initialising a system, whereas those factors are the key component of the interaction between learners and the e-learning system under study.

### ***3.3 Physiological Learning Category***

As stated earlier (2.5.2), stages of identifying learner's learning preferences require different phases such as filling a questionnaire by the learner so to learn about his/her learning preferences. This is one of the key references on the design and production of different types of learning materials and at the same time a category must be chosen later on for its method on identifying the learner's learning style using the shortest possible method compared to other complicated and lengthy methods such as Mayer-Brigg's Type Indicator (MBTI, 2009). In this case, all a learner does is to answer a series of questions. For example in physiological learning preferences a learner has to answer thirteen questions (Fleming, N.D., 2006), rather than the tens of questions s/he

would get from using, a questionnaire designed based on MBTI method, which in turn will not create the sense of self-preservation from continuing the course through the use of this system. It is worth mentioning that the concept described by the phrase “an environment does not create a sense of self-preservation”, means that the user of such environments will not have the freedom to control and change their learning space and as such they provide their feedback within those limitations. This can lead to feedback being constrained by the exigencies of their interaction with the environment, and the impact of that on their learning. This approach with the use of a specific method of identifying learning preferences has created a wide range of options, which is studied further in Appendix 17; it also tries to find the relationship between an individual’s learning style and his/her learning performance. The following list is an analysis of learners’ physiological factors to identify his/her learning style:

**Visual:** individuals with a visual type of physiological learning preference would prefer to view concepts and understandings in the form of a picture, and learn through finding relationships between its collective objects rather than going through its individual components, such as the individual characters in a word. The methods of presenting information would be in the form of symbols, arrows, charts, diagrams, graphs, and any type of visually-based representation that could be used to transfer the information. This category holds the sub-category of Read/Write types of learning preference, as described in Appendix 17.

**Auditory:** this is another perceptual mode of learning where the learner would prefer to obtain information in an auditory form. In principle, any method of communication via an audio-enabled environment is a determinant factor of learners with an auditory

type of learning style. A few examples of preferred methods of interaction for individuals with auditory types of learning style are group discussion, speaking, verbal tutorials and lectures, listening to tapes or CDs, talking things through and web chats. This type of learning style has been analysed further in Appendix 17.

**Read and Write:** read and write has been categorised as another physiological type of learning style. In this category, information is presented as words – or to clarify it better, a standardised format of shapes. This preference emphasises text-based input and output, and reading and writing in all its forms. This learning preference has been disseminated to another visual format as they share the same attributes. The process of its creation method has been described in Appendix 17.

**Kinaesthetic and Tactile:** in this category, the perceptual preference of communication is a combination of previously mentioned learning styles with experience and practice (Fleming & Mills, 1992). This section in itself has not been considered as a separate type of learning preference in the design of AAPLES. It is the interaction between other perceptual preferences of communication which forms the type of kinaesthetic/tactile type of materials. A detailed description of this type of modality has been described further in Appendix 17.

From now on to simplify referencing to elements of physiological learning categories, the acronym VARK is used which stands for “V” for video, “A” for audio, “R” for read/write, and “K” for kinaesthetic/tactile.

### **3.4 Control systems**

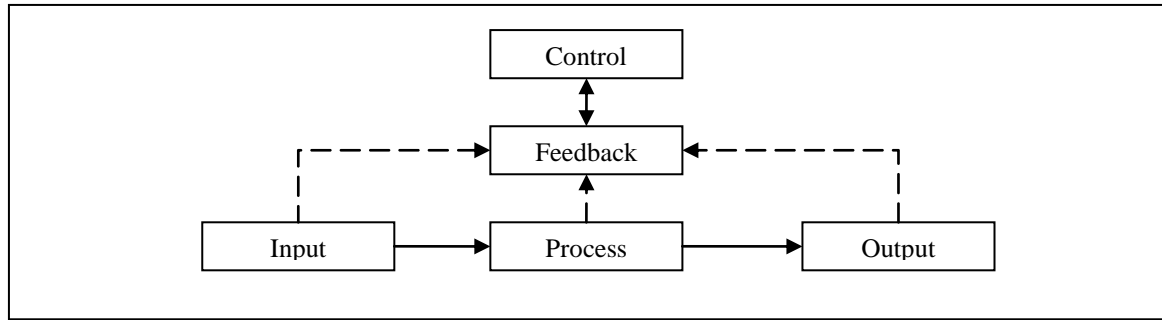
Control systems are key to the design of e-learning systems and are the different types, therefore discussed in this section. Any type of control system requires i) evaluation of the feedback from the end unit (by unit we mean a sub-component of an e-learning system) or the output of a unit, and ii) a control unit to measure that feedback so to make necessary adjustments to a system to improve its performance based on the characteristics defined by its designer or user.

These control systems that study the feedback received from a unit (either the output or from a different unit) are called closed-loop control systems. For the purpose of this research and since this research requires the measure of control of learners' learning performance in an adaptable personalised e-learning system, it is necessary to learn about the different types of control system. They are:

- i) Closed-loop feed-back control system
- ii) Closed-loop feed-forward control system

#### **3.4.1 Closed-loop Control system**

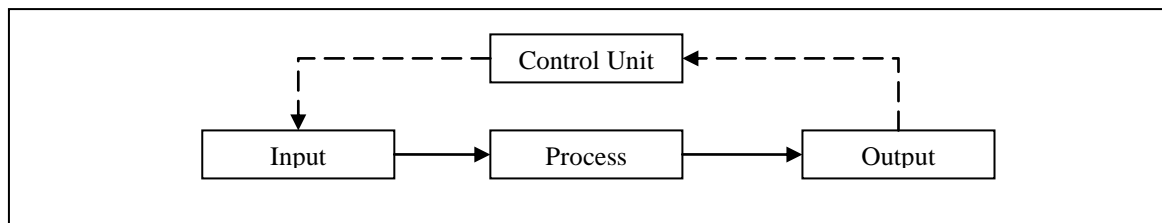
In a generic model of a system (Figure 6), feedback is gathered from a variety of sections of the system (input, process and output sections) and provides enough information for the control unit to allow it to make the right decision (Golten, J. & Verwer, A., 1991; Bocij, P., Chaffey, D., Greasley, A. & Hickie, S., 2006). There are two different ways of feeding the system via the control unit: i) the closed-loop feedback control system and, ii) the closed-loop feed-forward control system.



**Figure 6:** *A generic model of system*

### **Closed-Loop Feed-Back Control System (CLFB)**

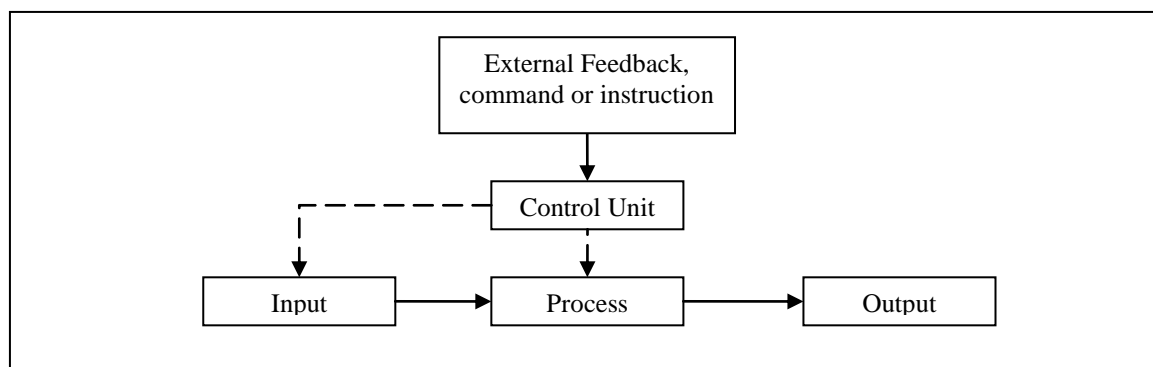
Figure 7 (below) demonstrates a system environment where control is achieved by receiving feedback from the different parts of the system and injecting new information into the system.



**Figure 7:** *Closed-loop Feed-back control system*

### **Closed-Loop Feed-Forward Control System (CLFF)**

Figure 8 demonstrates a system environment where control is achieved by receiving feedback from the external command unit in the form of an interaction and then passing on new information to change the output for the best compatibility of the new data with the decision made by the control unit.



**Figure 8:** *Closed-loop feed-forward control system*

At first sight, the feed-forward loop is similar to the feed-back loop. However, the major difference is the source of the control unit. In the feed-back loop, the source is being fed from the output; however, in the feed-forward loop, the source of the feeding comes from outside of that loop and, as shown in Figure 8, there are no loops that the data could move around and so basically all arrows point to the output (Golten, J. & Verwer, A., 1991; Bocij, P., Chaffey, D., Greasley, A. & Hickie, S., 2006).

### **3.5 Conclusion of this chapter**

In this chapter issues in designing an adaptable, adaptive and/or personalised e-learning system were discussed. Since the qualitative method was expected to provide the necessary evidence on any relationship between learners' learning preferences in different online learning environment, the model designed by Stone & Koskinen (2002) was studied to provide a direction for this research. Furthermore, our understandings on the system required further investigation on the concept of physiological learning categories, specifically of types visual (V), auditory (A), read and write (R), and kinaesthetic and tactile (K). The relationship between these types

of learning preferences and any online learning environment requires a controlling system where content materials would be selected based upon them. As such, two types of closed-loop control systems (feed-forward and feed-back closed-loop control systems) were discussed which provides the necessary understanding on the impact of learners' measure of control given to either of the learners or the system, which in turn solidify the reasoning for having a control system to select the learning materials based upon learners' learning preferences.

## **Chapter 4      Designing an Adaptable, Adaptive and/or Personalised E-Learning System**

### **4.1 Overview**

This chapter discusses designs drawn from chapter three and their relevance to the investigation done on the hypothesis of finding any relationship between learners' learning preferences and types of e-learning systems in terms of their effect on their learning performance. There are eight categories of e-learning systems (section 4.8) which have been analysed and designed based on the type of interaction between systems and learners, or more accurately in terms of types of assessments done before and during the attempt to take a course. These are based on different learning styles and knowledge assessments which are used to instantiate systems variables, there are fifty two types of e-learning systems which has been analysed and designed (appendices in the production log – see section 4.8 for an explanation of these fifty two types of ELSs). The two selected types of ELSs are the ones which are investigated, further analysed, designed, developed and implemented.

### **4.2 Introduction**

Given that the purpose of this research is to investigate the effectiveness of learners' learning style on his/her learning performance (2.8) and to measure the effectiveness of such systems based on the control given to the learner, teacher or system, they (those systems) should assist with a measure of control given to the learner, teacher or type of e-learning system (in an adaptive form).



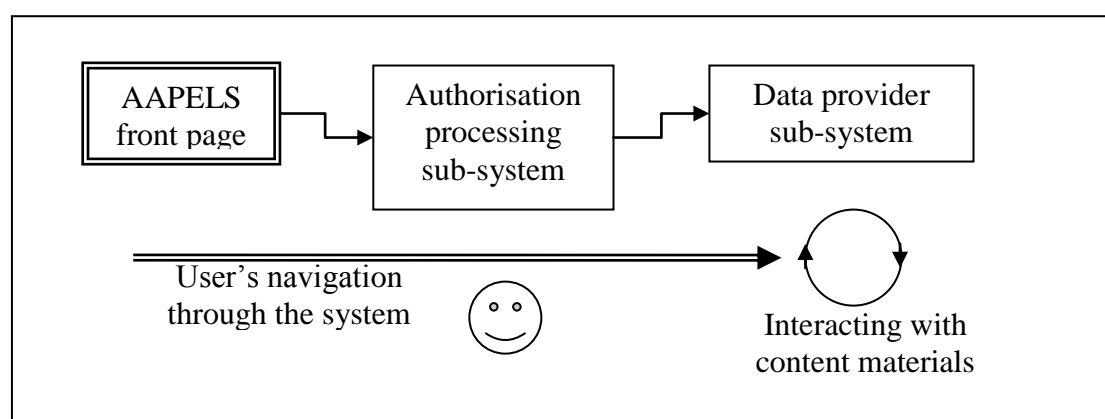
Furthermore, the measure of control given to the learner, teacher or system defines the type of e-learning system and the type of control unit. Moreover, as discussed earlier in section 3.4.1, there are different types of online learning system which require understanding of the feedback received from the user's interaction with the online learning environment in the form of tracking their interaction with content materials and navigating through the system itself to learn about self-evaluation, and so to create a personalised learning environment. These would work based on two major types of closed-loop controlling mechanisms (section 3.4.1). These types of feedback and feed-forward closed-loop controlling systems are the bases of the design and development of the adaptable, adaptive personalised e-learning systems investigated in this research. Additionally, the core of the control unit should be formulated based on two major fundamentals: i) the instructional design based on different learning philosophies (section 2.2.2) and ii) physiological learning categories (section 3.3) which determine the scope of how learning materials should be formatted and presented to different learners.

### ***4.3 Overview of the e-learning systems developed***

As any information system requires a form of navigation, to access and manipulate data stored in it, Figure 9 presents a high level view of the system navigation for adaptable personalised e-learning system under study. It is a combination of login process and data provider components. There are two sub-systems in the design and these are shown in Figure 10. A brief description of each sub-system follows,

The authorisation processing sub-system includes identifying authorised users and their type authorisation. Once logged in, users will then be redirected to the relevant

sub-system based on the authorisation they hold. The data provider sub-system includes core components of the system which is a combination of learning content materials, the system's control unit, content provider component which repackages the required learning materials content presenter, as illustrated further in Figure 10. This unit also includes a feedback unit which keeps track of the users' interaction with the system and stores that data in a database for future analysis. This diagram will be explained further in more details in later sections to clarify its sub-components and their relevancy to this research in terms of understanding the relationship between learners' learning performance and learner's learning preferences in different e-learning systems.



**Figure 9: High-level view of the system's navigation - 1**

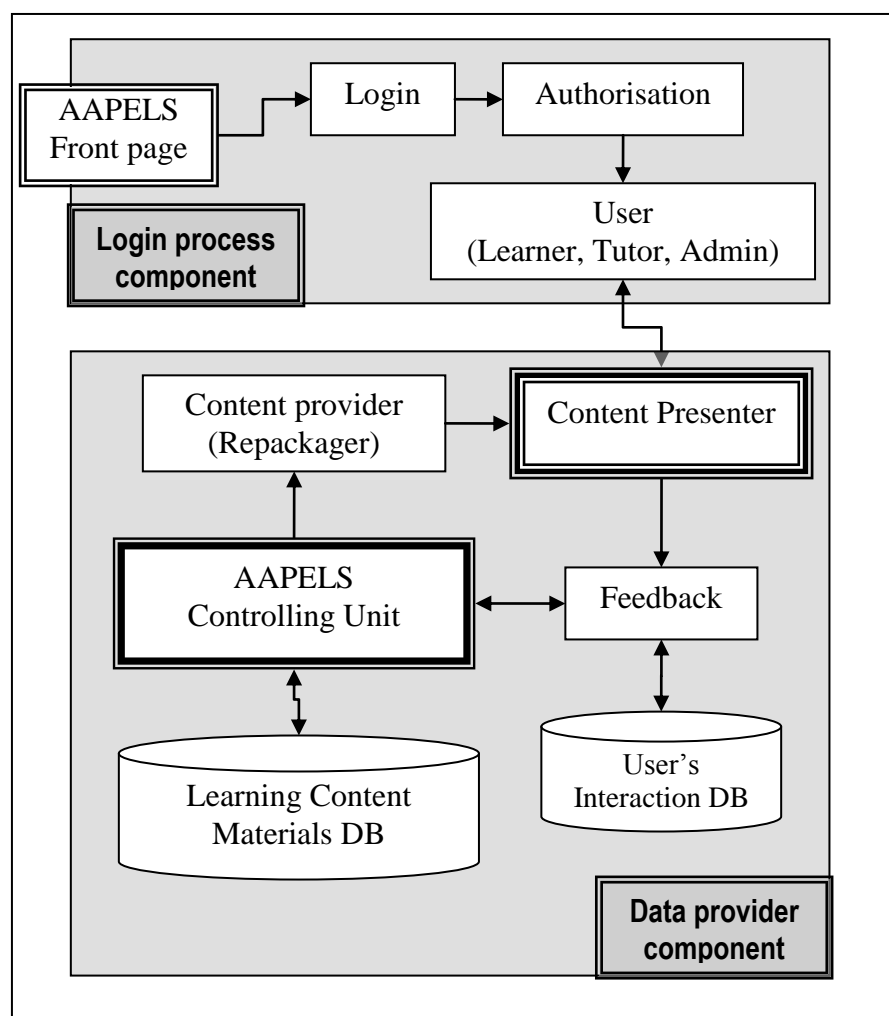


Figure 10: High-level view of the system's navigation - 2.

Further to discussions provided earlier and throughout this research, to investigate the relationship between learners' learning performance and types of e-learning systems based on their learning preferences, the next step is to have a discussion on the physiological learning category, and its role in this research with its effects on designing adaptable and personalised e-learning systems. It is noteworthy to say that the learner can not override the process of registration and the navigation through content materials. However, the learner can freely choose which topic of learning materials to start with.

#### **4.4 Physiological Learning Category**

The design of any system which works based on the feedback received from different units (3.4.1), requires a set of regulations to make the necessary adjustments back to the system, for example when a learner gives feedback to a questionnaire, it is considered as message to the system, so the next step would be the selection of appropriate types of content materials based on a learner's learning preferences and then the system will adjust its instantiated variables for the selection of relevant learning method. This is done through a mechanism which makes the message understandable by other parts of the system. Hence the control unit must be designed in such a way which its operation should be compatible with learner's learning preferences. This decision is mandatory to make sure that the core unit of the e-learning system under study works based on i) learner's interaction with the learning environment and ii) his/her learning preferences which in turn relates to the content materials provided via the learning environment.

For the purpose of this research it is decided to use four types of physiological learning preferences known as visual, auditory read/write and kinaesthetic/tactile types of learning preferences as discussed in sections 2.5.2 and 3.3. This decision is based solely on the i) availability of resources which leads with a less complicated learning environment compare to other learning preferences (such as temperature of the room, or learners wish to study in pairs or alone); ii) controlled learning environment based on the number of variables chosen for this study; and iii) the number and type of questions that have to be asked of the learner.

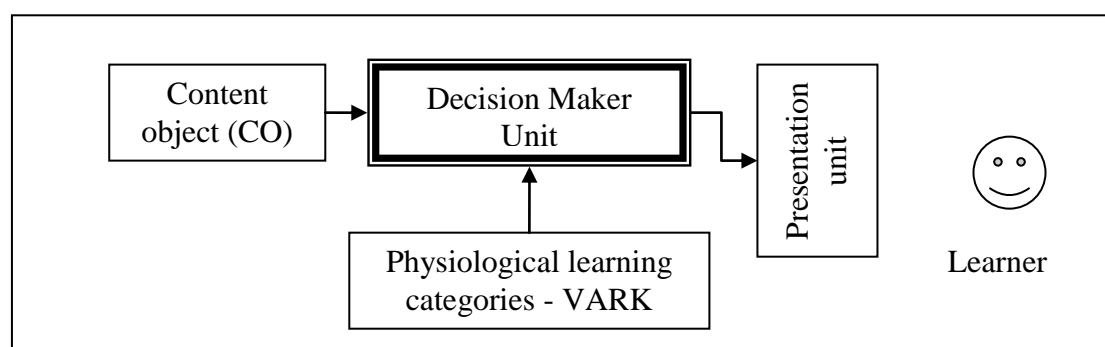
As a result of the discussion on the selection of the categories of four physiological learning preferences mentioned above, these main characteristics have been

considered as key factors in the process of identifying individuals' learning preferences for the reason of developing a learner's uniquely and specifically created learning materials.

#### **4.5 Content Object Provider System and Decision Maker Unit – From Concept to Design**

Given that any e-learning system is a type of learning management system and is used for the delivery of learning materials, and that learning materials are a collection of content material made up of structured, smaller objects with purposes or objectives known as content objects, the analysis of an e-learning system's structure and understanding the process of its design and development supports the understanding of the design and development of an adaptable, adaptive and/or personalised version of an e-learning system ( $A_v, A_L, P, ELS$ ).

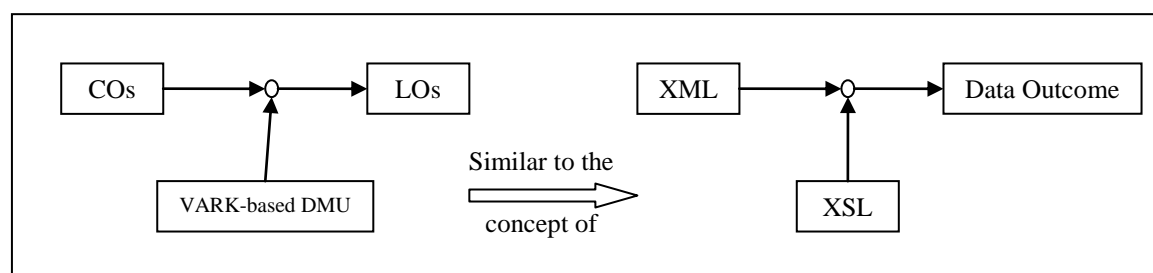
Furthermore, to investigate the relationship between i) content objects with the consideration of physiological learning categories (VARK – section 3.3), and ii) the process of selecting those content objects based on the learner's learning preferences (specifically VARK-based and not based on MBTI – Mayer Brig's type indicator or others), the need for developing a component called Decision Maker Unit (DMU) presents itself, since it is required to support building different types of e-learning systems -  $A_v, A_L, P, ELS$ s (Figure 11).



**Figure 11: Relationship between components of a basic structure of an e-learning system.**

The decision maker unit (DMU) in Figure 11 directly affects the selection of content objects from the depository of available COs (available to the system). The reason for using the term “available” is that there might be a set of COs under the process of development (in the development phase) while their digital assets – DAs – are being developed. Digital assets are at the lowest-level digital components which can’t be broken down into smaller useful components like an audio file, or a photo.

As mentioned earlier, the outcome of the above analysis would provide a better solution in designing an  $A_V, A_L, P, ELS$ . Figure 12 shows that structured XML and XSL are used to provide a set of data outcomes and in the same way, the VARK-based DMU is used to create a specific Learning Object (Appendix 17). Again, an explanation is necessary as to why the word “create” is being used here and not “select”. To simplify the definition of learning object, it could be said that it is a collection of all the content material needed to create a package which gives all the necessary materials to the learner, including learning, practice and assessment materials, in addition to meta data so that it is compatible with any e-learning system, which has been built to a standard, such ADL -SCORM (2004).



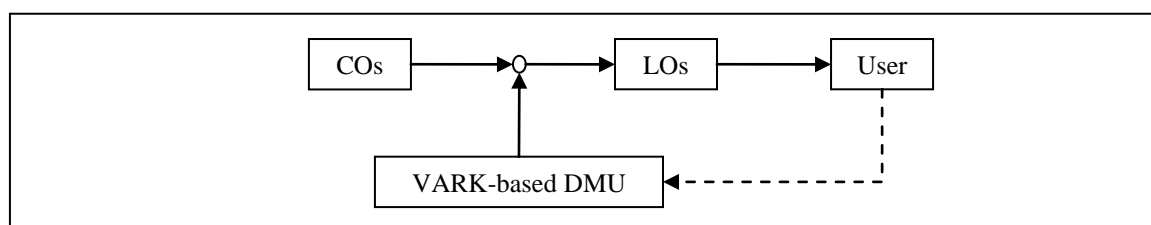
**Figure 12: Comparison of LO creation with the method used in data handling with XSL**

To clarify the diagrams in Figure 12 above, a variety of explanations can be given. One is the similarity of DMU within the XSL-XML-based data processing system.

XSL sets a query for the existing library of XML and so the outcome will be a filtered version of existing resources. In the same way, in this system, the DMU also makes decisions in selecting the type of CO to be passed on to a learning object viewer, accessible to the learner. But the principal point is that the DMU makes its decisions based on VARK-based learning preferences (LP), and thus the system functions as a Personalised ELS (PELS). However, the thought of “how a decision making unit (DMU) can be readjusted to make its decisions in the first place” results in three options:

i) If the resetting or instantiation process of variables required (so to let the system start work) is done by the learner, then the system is an adaptable e-learning system ( $A_L$ ELS), and ii) if the system itself is in control of finding out its instantiation of variables, the system is called an adaptive e-learning system ( $A_V$ ELS); and iii) of course, both systems have options of personalisation designed for them (in combination with both of them) which is that the learner nor the system will have the option of changing relevant variables after their instantiation process.

To have a controlled learning environment through an e-learning system (Figure 13), there must be an interaction within the decision maker unit to receive continuous feedback from a learner, to make the necessary adjustments to the next action if needed.

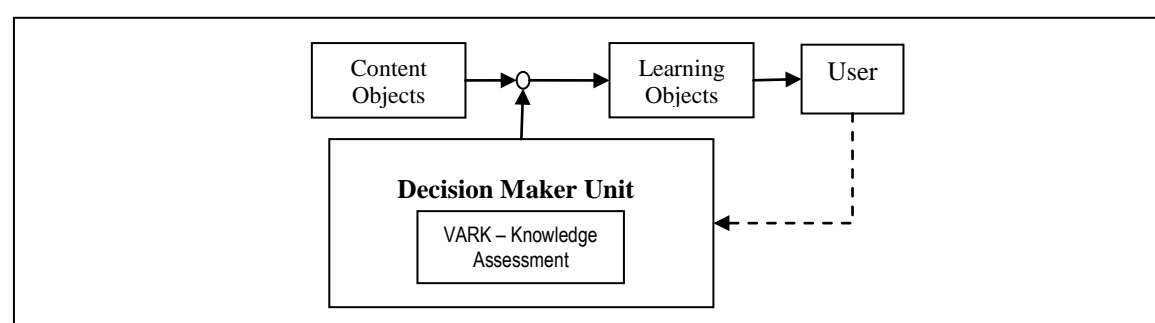


**Figure 13:** A basic type of closed-loop feedback schematic of an e-learning system for an adaptive adaptable personalised e-learning system

In Figure 13, for example, the decision maker unit makes its decision based on VARK learning categories, which ultimately selects a specific type of content object and presents the contents in the form of a learning object which then will be passed on to the user. The feedback received from the learner's interaction with the system will be another factor in the decision-making process of the next step.

#### **4.6 A high-level overview of a learning object creator for a personalised ELS**

As described in section 4.5, there is a need to have a decision maker unit (DMU) so that it is possible to make proper use of a user's feedback and so to measure the learner's sense of control over his/her learning environment in terms of learning performance; which in turn means that this unit makes its decisions based on the learner's learning preferences (Figure 14). This unit receives feedback from the user's activities and then decides what the next format of content object (CO) is.

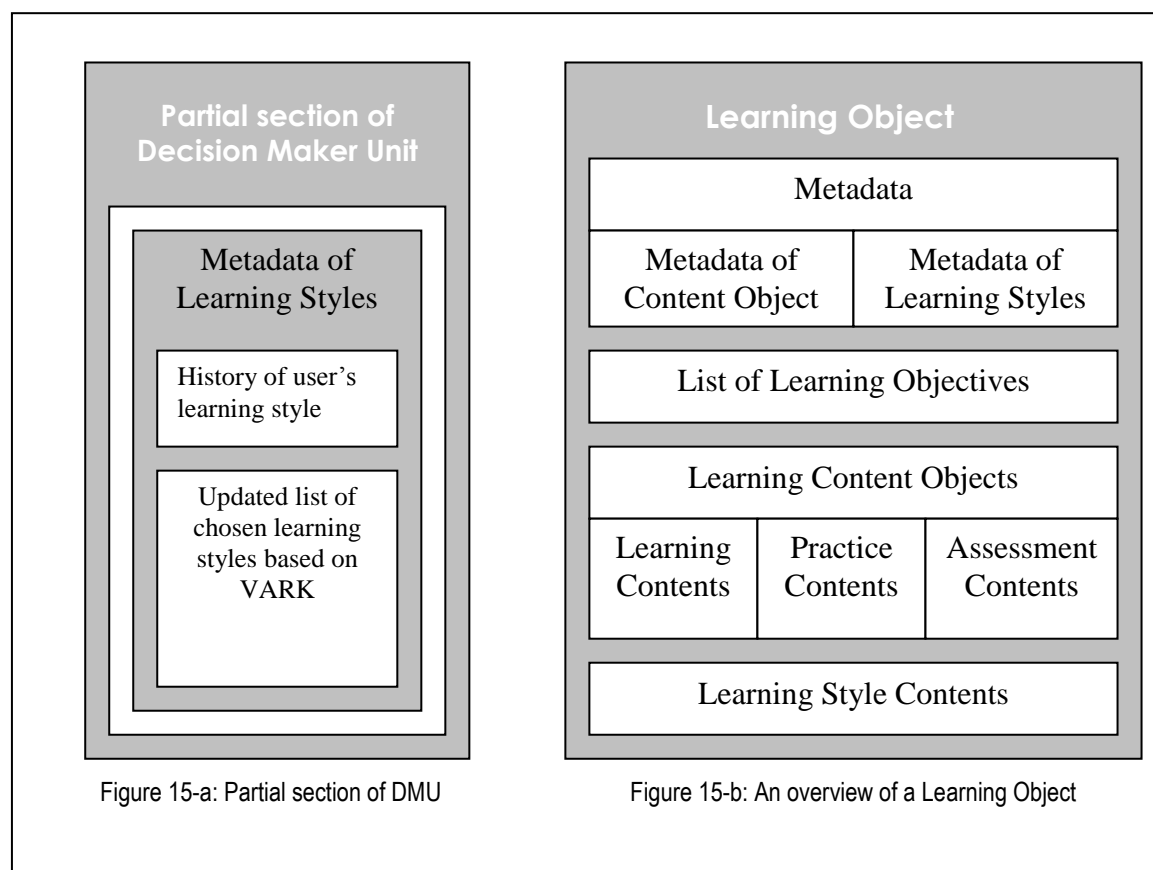


**Figure 14:** A basic high-level view of an adaptable, adaptive personalised e-learning system

To receive a learner's feedback, which happens at each interaction between the learner and the application's graphical user interface (GUI), the delivered content object must include a section called activity history. Within this activity history



section, the content object and metadata of the learner's learning style must be attached.



**Figure 15: Process of updates in the History of Learning Preferences (Styles) Unit (HLPU)**

#### **4.7 Analysis and Design of the Decision Maker Unit (DMU)**

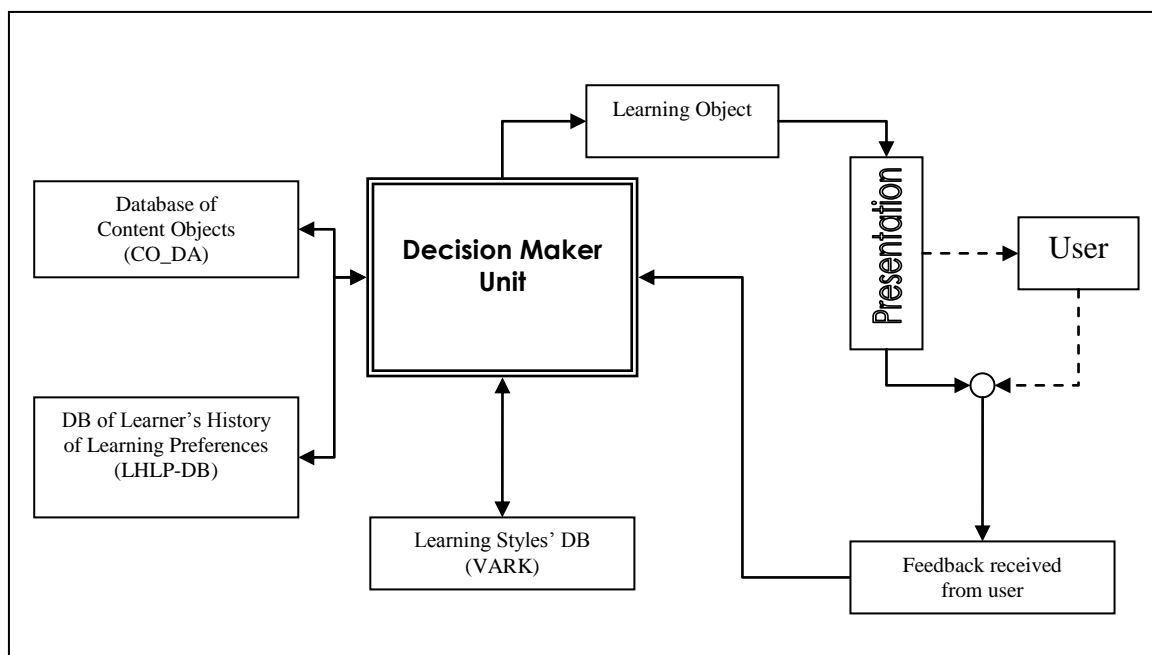
As this unit is the heart of an adaptive, adaptable and/or personalised e-learning system, it has a complex structure compared to other sections of the system; as it would and should be able to make the right decision based on the learner's learning preferences.

Figure 15 comprises of two figures; the Figure 15-a (partial section of the proposed Decision Maker Unit (DMU)) and Figure 15-b (an overview of a Learning Object). The decision maker unit (in Figure 15-a) will be described further in more detail in section 4.7.1; however the block in the figure presents a metadata format for the

learner's history of learning preferences. This is one of the main key factors in the process of making decisions about what to prepare and then how to present it to the learner in the form of a learning object (Figure 16). The second sub-figure (Figure 15-b) proposes a structure for the learning objects based on this study and specifically involves the learner's learning preferences. This figure has been discussed fully in Appendix 17.

#### **4.7.1 Analysis of the Decision Maker Unit (DMU)**

The decision maker unit is the core component of the current form of e-learning system where learners' sense of measure of control can play a key role in the development of their learning performance. Theoretically, this unit requires a sub-unit which has access to all content objects, learners' history of learning preferences and his/her learning styles, control over their interaction with the learning environment, and at the end the outcome of the decision made based on whatever algorithms have to be sent to learners in the form of a predefined unit of a learning material (package) known as a learning object. A simplified version of this unit is presented in Figure 16.



**Figure 16: A higher-level view of the Decision Maker Unit for processing a Learning Object Creator**

The diagram in Figure 16 presents a conceptual model for a decision maker unit (DMU) and other sub-sections required making it functional. The five main sections of the system are: 1. Database of Content Objects (CO-DA – which is a collection of metadata of digital assets, learning contents, practice contents and assessment contents). 2. Learner’s history of learning preference (LHLP-DB, where the system stores learners’ activities while interacting with the contents materials). 3. Learning styles’ DB (LSDB) – such as psychological and physiological assessment library – VARK-based assessment. 4. Feedback received from users. 5. Learning object package (LO), which acts as an outcome of the DMU and is to be passed on to the LO viewer.

The first and third sectors of the system (content object database and learning styles database) are in the form of a static database, and the second package or sector of the system (the learner’s history of learning preferences database) gets updated when either a learner or the system decides to change the learner’s learning preferences

(style) and the database gets updated by entries from the user in the form of feedback. These are types of data in response to a learner's activities on a presentation, which would update the history of the learner's preferences. As is obvious from this process, the DMU has a great dependency on this package (database of learner's history of learning preferences – HLPDB).

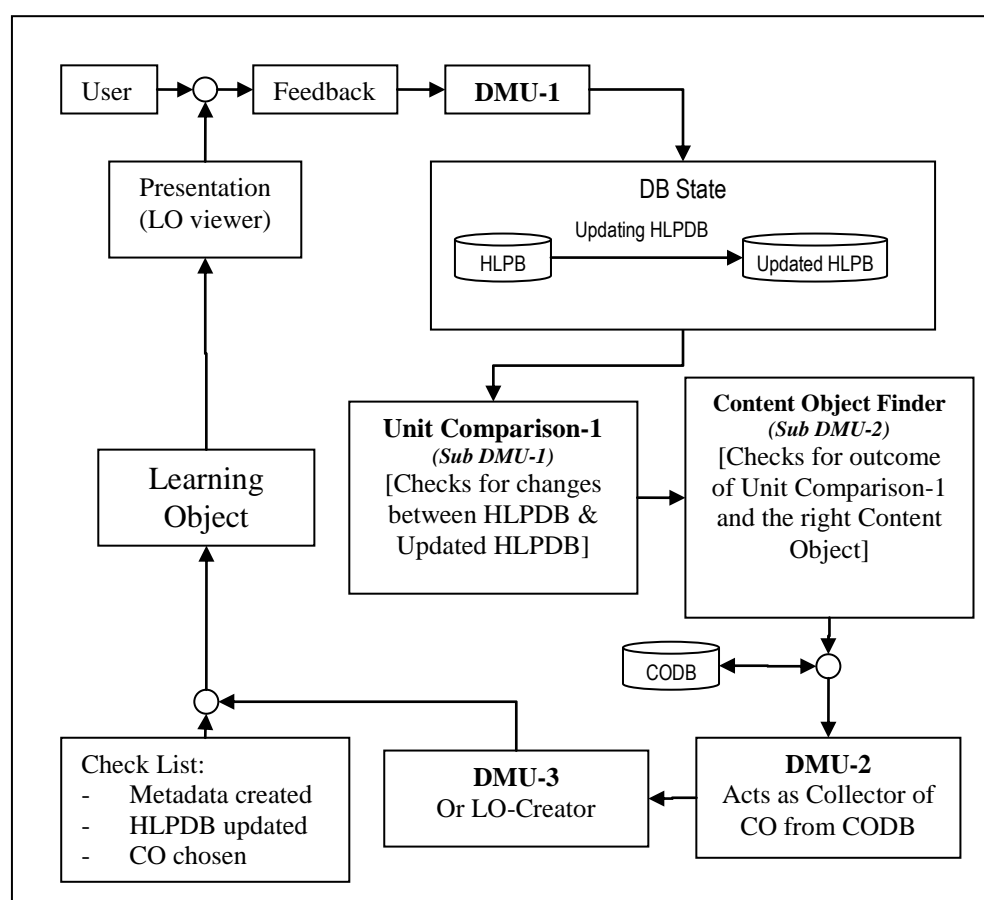
Learner's HLPDB is the main influential key in the decision-making process for the selection of the next type of a) Content Material (CM) in the form of an object (CO) and b) Learning Styles. DMU has access to both LSDB and CODB, for the whole time. It compares newly received feedback from the learner with his/her history of activities and then makes a decision.

#### **4.7.2 Proposing a Design for the Process of the Decision Making**

##### **Unit in an A<sub>V</sub>,A<sub>L</sub>,P,ELS**

While a user interacts with a GUI and sends his feedback in the form of either KW (Kinaesthetic form of contents with Writing, which would involve typing in characters via a keyboard) or KV (Kinaesthetic form of contents with visually based interaction with a user interface such as moving objects on the screen; this can be done via Flash-based files and the use of a cursor to drag and drop objects), the system collects such data and forwards them to the DMU. Now this unit has enough information to make the next action. It adds these records to the HLPDB and then, on that basis, it checks for the learner's history of changes on the base of the learner's learning preferences. By having these factors and information, the DMU then selects the most suitable type of COs from the CODB unit and prepares the Learning Object

so that is available to be used by the learner in the next part of the activity. These processes are described in the graph (pseudo-chart) below:



**Figure 17:** A high-level view of the e-learning system based on the learner's learning style.

By receiving feedback from the user after the presentation section (Figure 16 and Figure 17), a new decision would be made by DMU – which is a static form of process – without any changes on the two objects as below:

1. CO\_Type of the next session of LO would be the same as previous
2. Presentation template would be the same as previous

The reason why the DMU process is static in this form of process – PELS – is that if it was dynamic it would become another form of ELS called Adaptable and/or Adaptive ELS or Adaptable and/or Adaptive PELS. In that case, a DMU unit would receive different inputs for different entries (such as VARK-based GUI) from the

learner. By receiving different entries, the DMU compares the results, together with the learner's related histories of activities, and then makes a decision regarding which would be the next LO – on the basis of the CO\_Type and Presentation Template.

#### **4.8 Proposed forms of E-Learning Systems under study**

In addition to the methods of delivery of learning contents through a type of LMS, this study expands the design of an LMS further into eight different types which have been categorised based on whether they are a basic form of learning management system, personalised, or an adaptive and/or adaptable type of e-learning system. The list of possible categorisation is as follows:

1. ELS (E-Learning System): for further information the reader is referred to Appendix 1-1.
2. PELS (Personalised E-Learning System): for further information the reader is referred to Appendix 1-2.
3. A<sub>I</sub>ELS (Adaptable E-Learning System): for further information the reader is referred to Appendix 1-3.
4. A<sub>I</sub>PELS (Adaptable Personalised E-Learning System): for further information the reader is referred to section 4.8.1.
5. A<sub>V</sub>ELS (Adaptive E-Learning System): for further information the reader is referred to Appendix 1-4.
6. A<sub>V</sub>PELS (Adaptive Personalised E-Learning System): for further information the reader is referred to Appendix 1-6.
7. AAELS (Adaptive Adaptable E-Learning System): for further information the reader is referred to Appendix 1-7.
8. AAPELS (Adaptive Adaptable Personalised E-Learning System): for further information the reader is referred to Appendix 1-8.

With regard to the hypothesis under research, as discussed in section 2.8, this research attempts to investigate learners' learning performance with the "measure of control" given to the learner in using different types of e-learning systems, and as such, four

types of systems which have the element of adaptivity in them will not be investigated ( $A_V$ ELS,  $A_V$ PELS,  $A_VA_L$ ELS and  $A_VA_L$ PELS). The traditional ELS does not have the capability of measuring the learner's learning performance with the effect of giving a measure of control to the learner. The other two types of  $A_L$ ELS and PELS will have the capability of giving the measure of control to learners but without having the ability to compare both types of adaptability and personalisation of the system. Hence, the only option left is  $A_L$ PELS (adaptable personalised e-learning system) which has the ability to give the measure of control to learners and to measure their learning performance side by side with that freedom given to them. For further clarification, to investigate the number of types of e-learning systems, there are a few key elements, which need to be considered.

**User control or system control:**

Depending on the view of the interaction between learner, system and learning objects, the functioning of each element could be seen from two different views: learner-based and system-based controlling environments. Both controlling environments will be decided upon by the DMU (Decision Maker Unit). On the other hand, those environments are also divided into three main categories which are adaptability, adaptivity and personalised e-learning environments. To clarify the matter, let's find out about the number of variables in a typical e-learning system (relevant to this study), beginning with the definition of a few key variables (Table 2):

| Key variable definitions of types of ELS related to this study |  |  |
|--|--|--|
| Variables:   |  | Indicating   |
|  | 0  | The system is instantiated and it is set to a certain value, for example: $LP_0$<br>$\therefore LP_1 = LP_0$                   |
|  | ?  | The system is instantiated and it is set to a certain value determined by a questionnaire's outcome<br>$\therefore KA_1 = KA?$ |
|  | Learning Preferences (LP):<br>$LP_0 / LP?$ |  |
|  | $LP_0$ :                                   | Learning preference has been instantiated by the system  |
|  | $LP?$ :                                    | The instantiation of variables are made through finding the outcome of a test  |
|  | Knowledge Assessment (KA):<br>$KA_0 / KA?$ |  |
|  | $KA_0$ :                                   | Knowledge Assessment values has been instantiated by the system  |
|  | $KA?$ :                                    | The instantiation of variables are made through finding the outcome of a test  |
|  | Adaptability<br>$A_L$ :                    | Starts from some instantiated values and then those values could be re-adjusted again by the learner.                          |
|  | Adaptivity<br>$A_V$ :                      | Starts from somewhere and then the values could be re-adjusted again by the system (system learns).                            |
|  | Personalisation<br>$P$ :                   | Starts from somewhere. Those instantiated values will not be re-adjusted by the learner.                                       |

**Table 2: Key variable definitions of types of ELS related to this study**

With the consideration of different variables listed in Table 2, there will be fifty two different possible types of e-learning systems related to this study (all necessary documentations such as investigation on reasoning behind all these variables, coding and all other types of ELSs are included in the appendix in the production log).

However, only two will be designed and developed:

- i.  $A_{L-LP?+KA_0}$  ELS: adaptable e-learning system where the learner's learning preference will be questioned through a form including the instantiated knowledge assessment.
- ii.  $P_{LP?+KA_0}$  ELS: personalised e-learning system where the learner's learning preference will be questioned through a form and will not be changed afterwards including the instantiated knowledge assessment.



Thus, the key component of this research (the hypothesis mentioned in section 2.8) is finding any relationship between the two types of e-learning systems discussed above. The first is  $A_{L-LP+KA0}$ ELS, an adaptable e-learning system where the learner's learning preference will be questioned through a form including the instantiated knowledge assessment. At this stage, the value is all available learning objects. The second is  $P_{LP+KA0}$ ELS, a personalised e-learning system with both learning preference and knowledge assessment to be set to certain values in the same way as  $A_{L-LP+KA0}$ ELS, but with one difference. The key difference in this version is that in a personalised e-learning system, the learner will not be able to change any values after instantiation is done, unlike the type of adaptability where the system can continuously receive inputs from the learner, while navigating through learning materials.

| >>>>3. A <sub>L-LP?+KA0</sub> ELS<<<<<  |  |   |
|---|--|---|
| Detailed Processes  | Summary of actions   |   |
| <p><b>The system is instantiated on:</b><br/>           KA<sub>i</sub> = passed [KA0]<br/>           LP<sub>i</sub> = is required [LP?] (decided through a test)</p> <p><b>and then:</b><br/>           KA<sub>P</sub> = the learner is presented with all LOs and it is a changeable environment controlled by the learner and not the system<br/>           LP<sub>P</sub> = it is already decided upon and it is a changeable environment controlled by the learner and not the system</p> | <p><b>Instantiation:</b><br/>           KA<sub>0</sub> = ✓<br/>           LP<sub>0</sub> = ?</p> | Optional changes available to the   |
|   |  | <p><b>Learner:</b><br/>           KA = LOs ⊙ ≍<br/>           LP = LP<sub>i</sub> ≍</p> |

**Table 3: Structure of A<sub>L-LP?+KA0</sub>ELS's conditions and processes**

| >>>>15. P <sub>LP?+KA0</sub> ELS<<<<<  |  |   |
|--|--|---|
| Detailed Processes   | Summary of actions   |   |
| <p><b>The system is instantiated on:</b><br/>           KA<sub>i</sub> = passed [KA0]<br/>           LP<sub>i</sub> = is required [LP?] (decided through a test)</p> <p><b>and then:</b><br/>           KA<sub>P</sub> = The learner is presented with all LOs, but it is an unchangeable environment controlled by the system<br/>           LP<sub>P</sub> = it is already decided upon based on LP?, and it is an unchangeable environment controlled by the system</p> | <p><b>Instantiation:</b><br/>           KA<sub>0</sub> = ✓<br/>           LP<sub>0</sub> = ?</p> | Optional changes available to the   |
|  |  | <p><b>Learner:</b><br/>           KA = LOs ⊙ ≡<br/>           LP = LP<sub>i</sub> ≡</p> |

**Table 4: Structure of P<sub>LP?+KA0</sub>ELS's conditions and processes**

**Keys:**

- ☑ All accessible
- ⊙ Only those LOs which the learner has not passed
- ≍ Changeable
- ≡ Unchangeable
- ✓ Passed
- ? Is required
- ① The system tries to learn
- ①X The system tries to learn from the state of X

The categories above are presented in a summarised table as shown below:

|      | Usual LMS             | Adaptable                           | Adaptive                             | Adaptive-Adaptable                                  |
|------|-----------------------|-------------------------------------|--------------------------------------|---|
| ELS  | Appendix 1-1:<br>ELS  | Appendix 1-3:<br>A <sub>L</sub> ELS | Appendix 1-4:<br>A <sub>V</sub> ELS  | Appendix 1-7: A <sub>V</sub> A <sub>L</sub> ELS     |
| PELS | Appendix 1-2:<br>PELS | 4.8.1: A <sub>L</sub> PELS          | Appendix 1-6:<br>A <sub>V</sub> PELS | Appendix 1-8:<br>A <sub>V</sub> A <sub>L</sub> PELS |

**Table 5: List of varieties of ELS with their related section number for further description on their types.**

Online Content Management (OCM) functions as an online storage for presenting course materials. Its structure is a static type and if any changes would need to be made in relation to the method of presentation, they have to be done via a static type of interaction, either by the tutor or the instructional designer of the course.

As explained above (section 4.7.1), any e-learning system would require a type of DMU. Each DMU in itself uses different states of system control (CLFF and/or CLFB), which will be described further in the following sections. Each section will include a detailed description differentiating the understanding of the usability of these types of controlling system, and whether their processes are related to the whole e-learning system (ELS) or just the decision maker unit (DMU) [Table 6].

| Type of ELS                        | From the Learner's Point of View | Library of the Control Unit   | From the System's Point of View | Section       |
|------------------------------------|----------------------------------|---|---------------------------------|---------------|
| ELS*                               | CLFF                             | The system does not use any kind of library in relation to its controlling unit.  | CLFF                            | 0Appendix 1-1 |
| A <sub>L</sub> ELS                 | CLFF                             | The system starts updating the library of instantiation process data through the interaction of the learner with the system. This process starts with a set of tests.                     | CLFF                            | Appendix 1-3  |
| A <sub>V</sub> ELS                 | CLFB                             | Reads data from the library as instantiation values set by the A <sub>V</sub> process. The process which tries to learn from the learner's behaviour on interaction with the environment. | CLFF                            | Appendix 1-4  |
| A <sub>L</sub> A <sub>V</sub> ELS  | CLFF → CLFB                      | Reads data from the library as instantiation values set by the A <sub>L</sub> process which in turn instantiates values for the A <sub>V</sub> process.                                   | CLFF → CLFF                     | Appendix 1-7  |
| PELS                               | CLFF                             | Reads data from the library as instantiation values set by the system   | CLFF                            | Appendix 1-2  |
| A <sub>L</sub> PELS                | CLFF → CLFF                      | Reads data from the library set by outcome of the A <sub>L</sub> process  | CLFF → CLFF                     | 4.8.1         |
| A <sub>V</sub> PELS                | CLFB → CLFF                      | Reads data from the library set by outcome of the A <sub>V</sub> process  | CLFB → CLFF                     | Appendix 1-6  |
| A <sub>L</sub> A <sub>V</sub> PELS | CLFF → CLFB → CLFF               | Reads data from the library set by outcome of the A <sub>V</sub> process, which in turn was set by A <sub>L</sub> process   | CLFF → CLFB → CLFF              | Appendix 1-8  |

\* ELS only as an LCMS (E-Learning System only as an Learning Content Management System)

**Table 6: Types of ELS with relevant states of controlling system**

The details above are included in the following section.

### 4.8.1 A<sub>L</sub>PELS (Adaptable Personalised E-Learning System)

In this category, learning objects (LOs) are chosen by the DMU on the basis of identifying the learner's learning preferences (LP) or knowledge assessment (KA) outcome and then creating LOs based on LP-KA related content material (Figure 18). There are four different types of ALPELS depending on the type of instantiated value. The process of instantiation is configured by either the system or the learner's outcome of a test, which leads to four different types of ALPELS. However, the key factor here is that both AL (adaptability) and P (personalisation) cannot share the same LP-KA types. The reason for this is that ALPELS in the same category is not possible, because adaptability is about possible continuous changes and personalisation is about the user not being able to make any change to any key elements of the user profile stored in the system. However, they could be part of one system but not share the same element (KA-knowledge assessment and LP-Learning preference), such as having control over the same KA, LP or both. Thus:

$$A_LPELS = ELS + LP^S-KA^S-CO + (KA0/? +LP?/0)$$

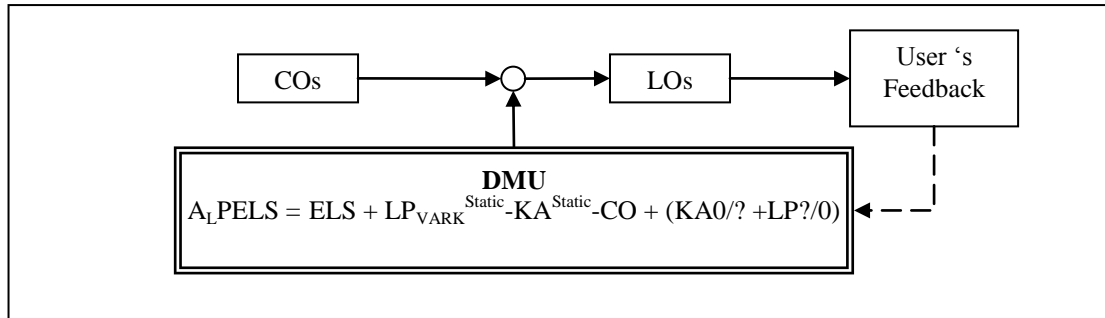
$A_LPELS = ELS + LP_{VARK}^{Static}-KA^{Static}-CO + (KA0/? +LP?/0)$  where both LP and KA do not share the same types

**Different possible types of A<sub>L</sub>(LP0 / LP?, KA0 / KA?) P(LP0 / LP?, KA0 / KA?)**

**[Both A<sub>L</sub> and P can't share the same (LP0 / LP?, KA0 / KA?)]**

1. A<sub>L-LP0+KA0</sub> P<sub>LP?+KA?</sub>,
2. A<sub>L-LP0+KA?</sub> P<sub>LP?+KA0</sub>,
3. A<sub>L-LP?+KA0</sub> P<sub>LP0+KA?</sub>,
4. A<sub>L-LP?+KA?</sub> P<sub>LP0+KA0</sub>,

$LP_{\text{VARK}}^{\text{Static}} - KA^{\text{Static}} - CO + (KA0/? + LP?/0)$  where both LP and KA do not share the same type: a static type of learning preference-based and knowledge assessment-based content objects, where LP is based on VARK. LP and KA are/or determined statically via a questionnaire or instantiated by the system (read from the library). Once it is determined, it will not be changed by the system.



**Figure 18: Schematic of  $A_LPELS$**

**Type of technique used in the control unit (DMU) for the  $A_LPELS$ :**

This is a three-section mechanism (Table 7):

- i. A learner takes an LP and/or KA test(s). The system updates the learner's learning profile with this information.
- ii. The control unit would then make its decisions on the basis of the learner's LP-KA values stored in the library, and creates a new list of Learning Objects. This list will be presented to the learner at the time of his request. At this stage the control unit is in the state of CLFF.
- iii. Now the controlling mechanism of the system would be in the state of CLFF. The system has already made a distinction between the available types of learning objects and is ready to be presented to the learner. At this stage, it is the will of the learner to navigate through the existing accessible and relevant learning objects.

| Subjects and their status                               |                      | Status of the controlling unit of the DMU and what learner's options would be through the GUI presented by the system |   |  |   |   |
|---|----------------------|---|---|--|---|---|
| Subject   | State of the subject |   |   |  |   |   |
| The DMU through the System                              | is in the state of   | CLFF  | → | CLFB   | → | CLFF  |
|   | Does                 | Updating LH-DB  |   | Preparing a list of LOs based on LP-KA's outcome from the library                                |   | The system will keep track of the learner's activities and check if there is another update on his knowledge assessment |
| State of interaction between the Learner and the system |                      | ↕   |   | ↕  |   | ↕   |
| Learner interacting through GUI decided by DMU          | is in the state of   | Giving tests depending on the sub-type of the system (0/?)  |   | Receiving a new list of LOs decided by DMU   |   | Navigating through LOs and having access to change instantiated values  |
|   | Does                 | Doing either LP and/or KA test(s)   |   | Viewing the list of LOs developed based on his LP-KA outcome or set (instantiated) by the system |   | Selecting and going through individual LOs. The option of changing instantiated values are also available               |

**Table 7: Stages of techniques and interaction between Control Unit (DMU) and a Learner for the A<sub>L</sub>PELS.**

#### **4.9 A Framework for designing assessment questions**

Throughout this research it has been mentioned that a learner interacts with the system and then the decision maker unit makes its decision based on the feedback received from the learner, while navigating through the content material. Since the bases of this research is to investigate the learner's learning performance in different learning environments, the measurement of this performance will be done via sets of assessments (section 2.4). On that basis, different methods are used to measure different types of knowledge gained by a typical learner. The Recalling (R) type of

assessment questions is used for measuring the basic knowledge; the Competency (C) type is to measure the procedural type of knowledge; and the Understanding (U) type of assessment questions are utilised to give a framework for designing assessment questions to measure learners' conceptual knowledge (Shute, Valerie and Towle, 2003).

#### **4.10 Concluding Remarks**

In this chapter, different key elements involved in the process of making a decision in designing an e-learning system were studied, factors such as the role of the decision maker unit, feedback-based control systems and learning about the categorisation of different types of e-learning system were part of the main topics. The system that was decided upon was selected in a way that should provide the capability of measuring learners' learning performance so that they can have the measure of control over their learning environment. This procedure applies in a form which the system learns from the students' choices, so the measure of learner control becomes embedded in the automated selection of contents.

The current system model would be used to gather learners' interactions with different online learning environments based on their learning preferences and to find any relationship between the two (i.e. the types of e-learning systems used and their learning preferences, as mentioned above) and their learning performance in order to investigate the hypothesis discussed in section 2.8.

In the following chapter the third phase of the system will be discussed which is the development stage of this study. As far as this study is concerned, the framework of the design and development of the e-learning system would be Adaptable Personalised E-Learning System (A<sub>L</sub>PELS).



## **Chapter 5      Experimental Design for A<sub>L</sub>PELS (Design, Development and Implementation of A<sub>L</sub>PELS)**

### **5.1 Overview**

This chapter discusses the combination of arguments on i) e-learning systems, ii) learning objects, and iii) their related designs. Section 2.8 designs a framework to look for answers on the possible relationship between a) learner's learning style, and b) different types of e-learning systems; therefore, the learning environment under design must possess such data-collection mechanisms which would allow investigation of the measure of control given to the learner in terms of his/her learning progress.

Hence, the design phase for the adaptable personalised e-learning system under study includes navigation of the system, steps towards the design and development of digital assets and how to relate them to the use of meta data in the form of a content object which is used by a learning object, and an ARK-based switchboard which simplifies the process of development of many different types of learning objects which are required for this study.

### **5.2 Introduction**

In this chapter the process of design, development and implementation of A<sub>L</sub>PELS is discussed. It includes a thorough investigation of the challenges involved in the design and development of the system.

Detailed stages of the design have been provided in the appendices. The documentation for the development stage of the system is presented in the production log of the thesis. The aforementioned production log includes design, codes and screen captures of all major units involved in the project. However, no coding of individual digital assets has been added to the appendices (such as contents of each digital asset for any topic of the module) as those have been developed by code generator application software. Those applications are: Microsoft PowerPoint for the preparation of a series of slides, an audio recorder of the MS PowerPoint application and Macromedia Breeze to convert existing presentations into a Flash type of file. These types of files would ease the process of integration and management of Flash files into web applications.

### ***5.3 Major aspects of the design phase of A<sub>L</sub>PELS***

During the design phase it was known that there are a variety of different key factors that play a major role in producing a suitable application framework to support A<sub>L</sub>PELS. The first step would be drawing out sets of criteria to define the framework of this stage.

#### **Criteria for designing the system**

The following is a list of criteria for designing and developing the above-mentioned system:

- System navigation: to direct users of the system to different sections so they can pursue their needs.
- Metadata: of digital assets, contents materials, learning objects, subjects and topics for the. These data would be stored on a database.
- User interfaces: to give users of the system enough information and accessible facilities for informative-based navigation through different sections of the system.

### **System navigation - 1**

This section will present a high-level view of the user interaction with the system (Figure 19). Since the core section of the system is the decision maker unit and it is designed based on the schematic discussed (and agreed upon) in Figure 18, its process of registration and letting the system learn about his/her level of knowledge and learning styles is illustrated in it. Types of authorised users of the system are:

- Administrators: who will manage and administer the whole system and user accounts.
- Instructional Designers: who have access to online content material. In this version of the system the user with an “Administrator” account will have the same authority.
- Tutors: those users of the system who have access to learners’ activities and reports of their interaction with the system.
- Learners: those users of the system who have access to learning materials.

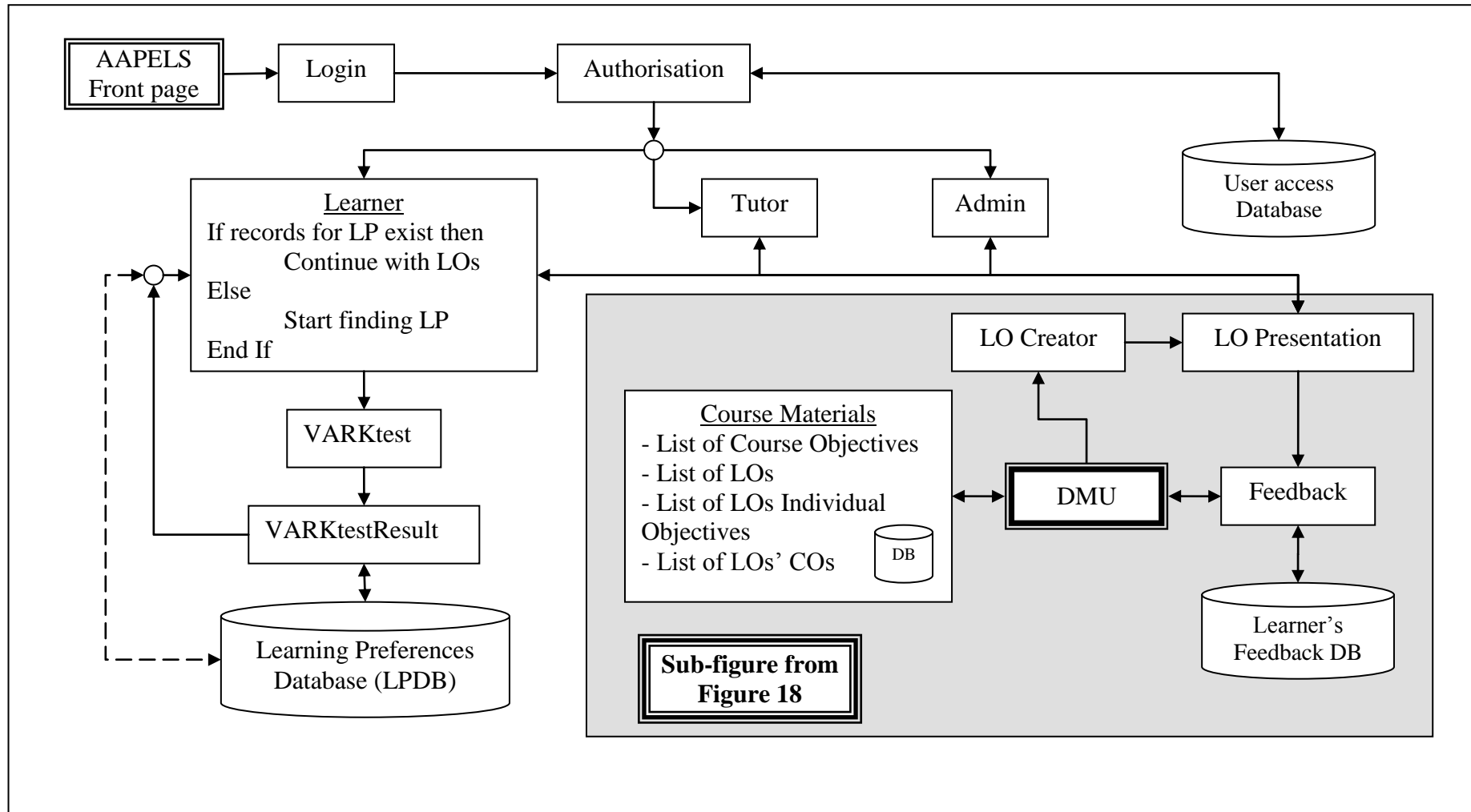


Figure 19: High-level view of the system

In this figure, authorised users' access is evaluated through the database "User access database" which will have to be divided into three groups as was mentioned earlier. Between those groups of users, learners have to take an assessment based on VARK so their learning preferences can be determined for the system and the outcome is stored in the "Learning Preferences Database (LPDB)". After the authorisation, all users, mainly the learners, will have access to the learning object presentation unit (LO Presentation) to view and interact with learning objects. Details of the unit named "Sub figure from Figure 18" have already been discussed in section 4.8.1, which is the decision maker unit selects the relevant content material and presents them to the learner, then the feedback received from the learner's interaction is stored in the "Learner's Feedback DB" and is then reprocessed, which leads to the new selection of content material based on the type of decision maker unit and the learner's interaction.

In the sub-figure of Figure 19 the content material unit includes a list of learning objects (LOs) which provides the list to the decision maker unit to allow the next content material to be selected (Figure 20) and then presented to the learner.

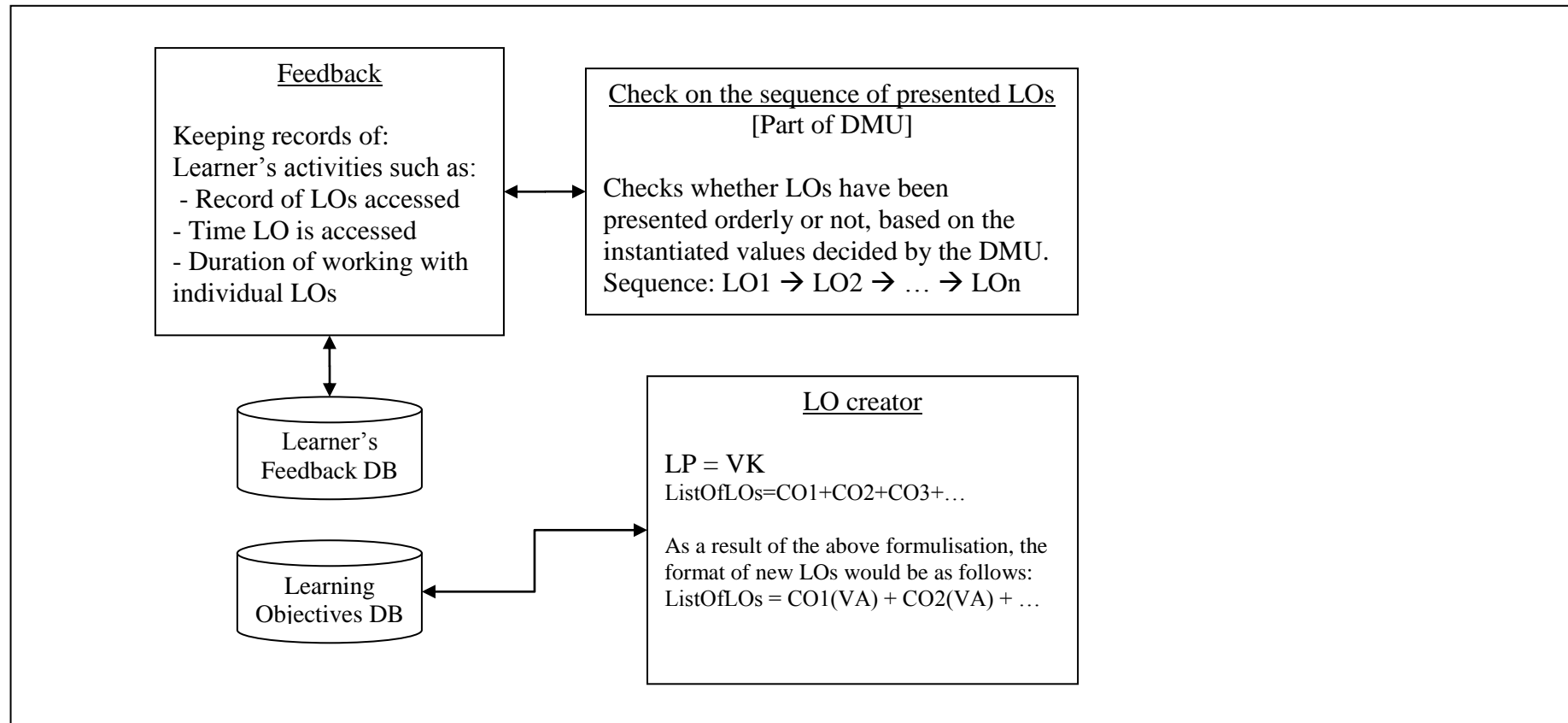


Figure 20: High-level view of the system from the Learning Objects' point of view

## Registration - 1

In this phase, students who have registered for the MSc Induction course (COSK1003), and are ready to continue their course, would receive login details to the site via email.

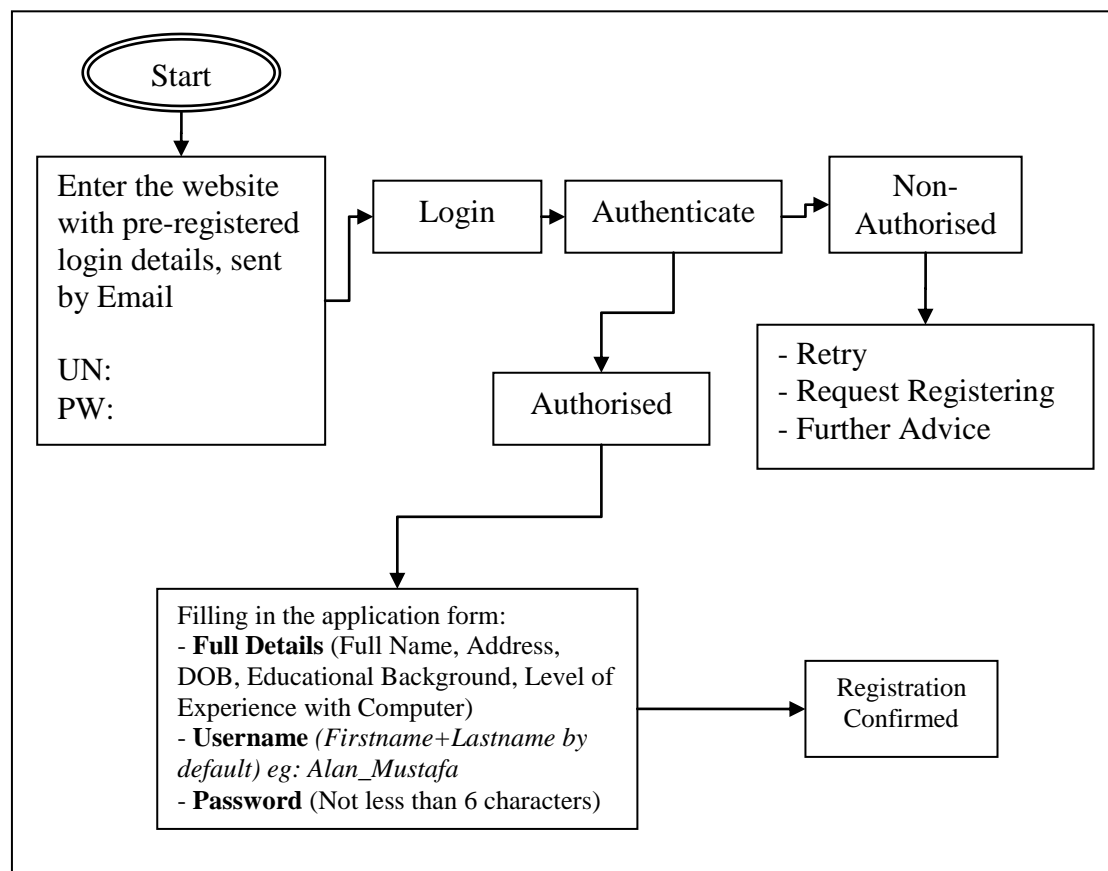
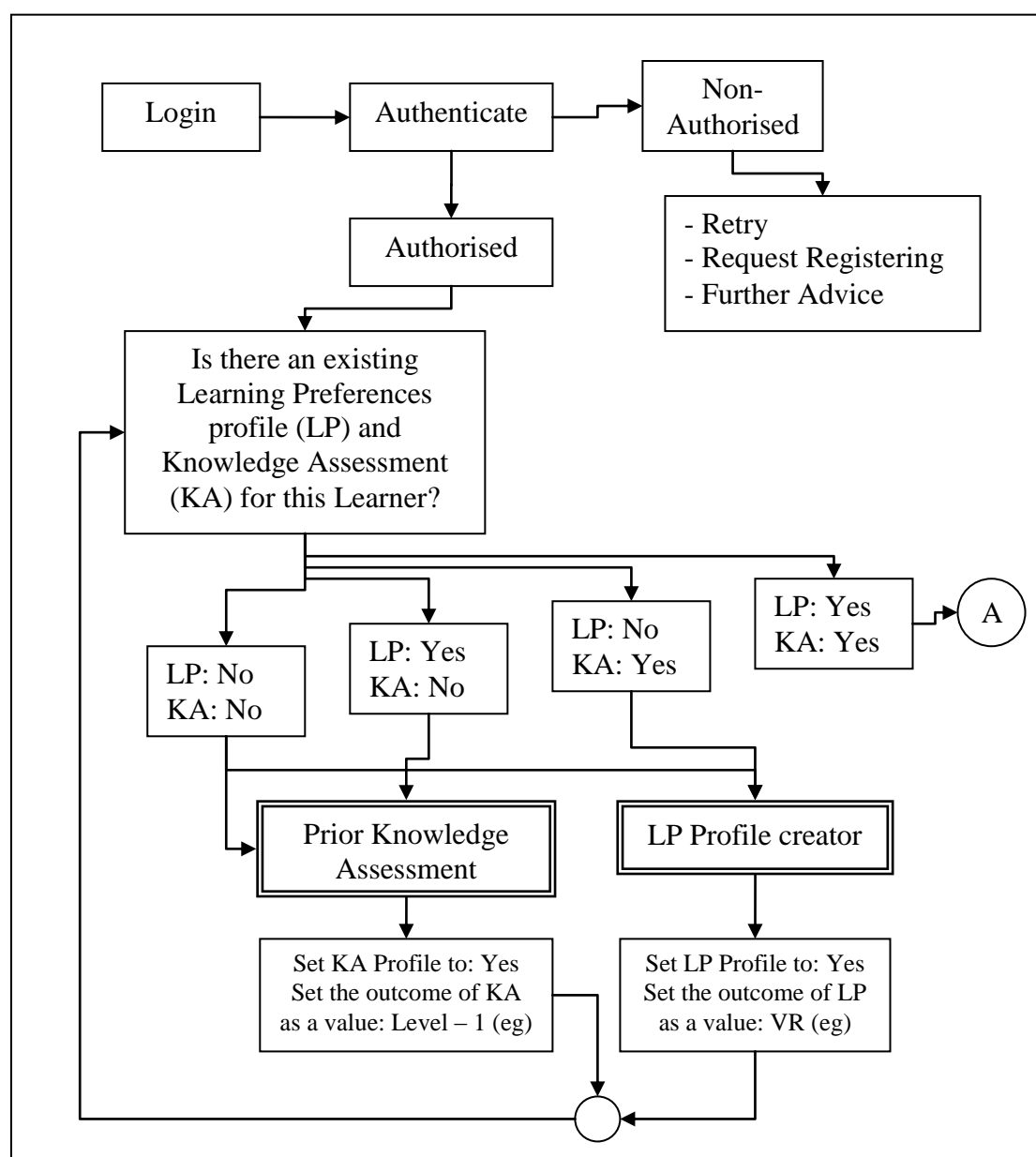


Figure 21: Steps involved in checking the user's authentication

**Registration cont. -2**

In this phase, students who are fully registered in the AAPELS web application would be asked to create a profile with two sections Learner's Learning Preferences profile and Prior Knowledge profile.



**Figure 22: High-level design of the system for updating the learner's profile**



**Registration cont. -3**

In this phase, the system would categorise students into two main groups without the learner's knowledge.

- 1- ELS users (E-Learning System)
- 2- PELS users (Personalised E-Learning System)

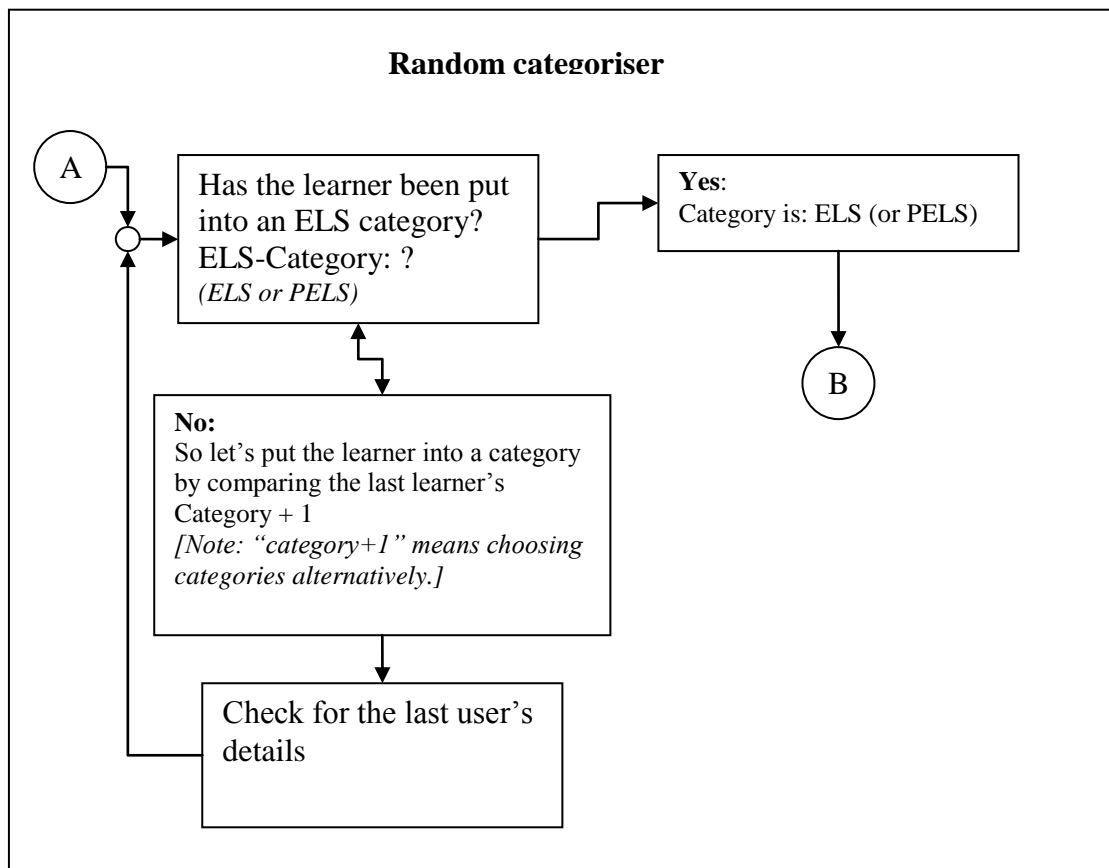


Figure 23: Continuation of Figure 22.

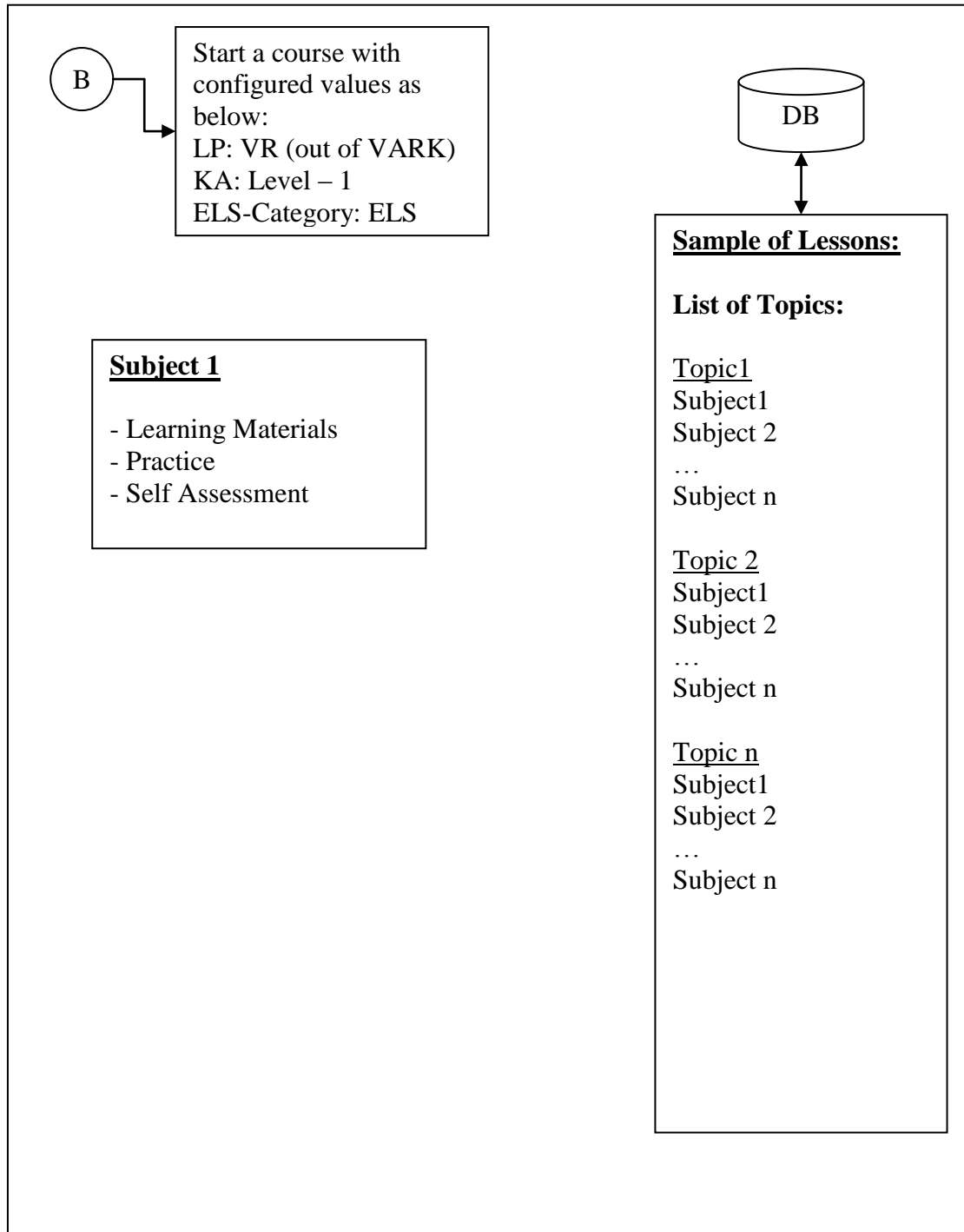
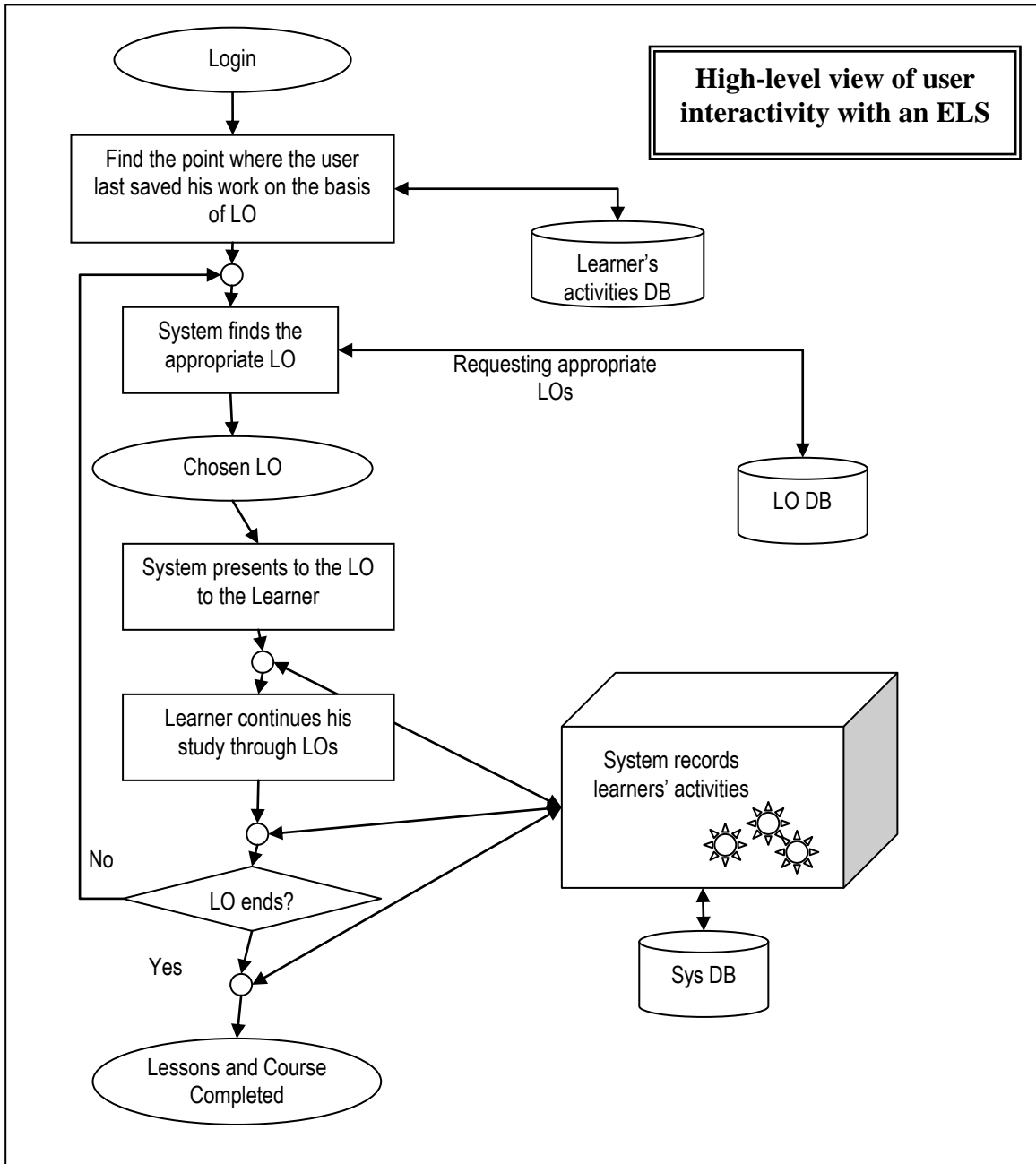


Figure 24: Continuation of Figure 23.

## System navigation - 2

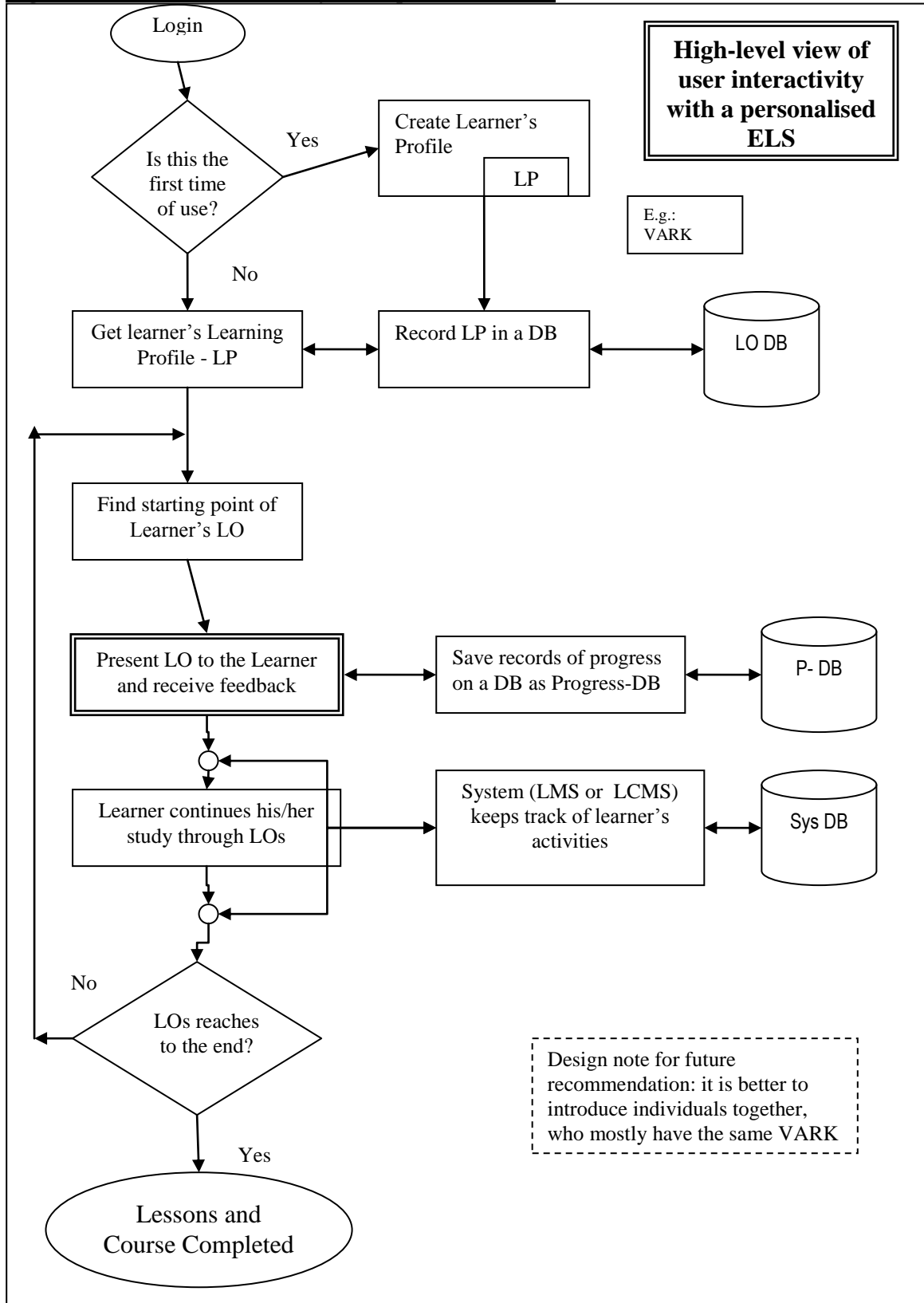
After the completion of the registration of a learner, s/he will be given access to all available course materials.

### High level view of user interactivity with an ELS



**Figure 25: Learner navigation map through the ELS.**

**High-level view of user interactivity with a personalised ELS**



**Figure 26: Navigation map for the learner within PEELS.**

Design and prototype for the procedural method of creating digital assets, contents provider systems and activity tracker systems.

This section presents and discusses designs and prototypes used for the designing of the A<sub>L</sub>PELS, which will discuss templates for designing a digital asset presenter (the first draft of the design), a proposal on methods of creating digital assets, a system of content material provider, a prototype for designing the database and the blueprint of an activity tracker system.

### **Creating a template for developing DAs**

To draw a draft user interface for the system, a template was developed to show what could be presented via a slide. Details of the first attempt are included in Appendix 2. These templates present four types of VARK-based user interaction with content objects; they are VA, VR, AR and VAR.

This process has set a framework of how content material (CO – as a collection of digital assets) should be presented to learners. This was the first attempt at the design and development of learning materials.

### **Types and methods of creating DAs**

As mentioned earlier in Appendix 2, with full step-by-step descriptions of the analysis of individual VARK-based digital assets, the individual development process and how to develop them individually with the existing available technology is included.

Different methods exist for the purpose of developing VARK-based digital assets. A sample method has been proposed for the development of each type of VARK and this is presented in Appendix 3.

### **System of Contents Provider**

To relate the discussion between the process of developing digital assets and learning preference-based content material (the relation between the development of DA and LP-based COs) to the creation of an organisational structure for learning objects, drafts have been designed. Discussion on these blueprints for designing a structure for the metadata is included in Appendix 4.

As this section is about designing the A<sub>L</sub>PELS, it is worth mentioning that to find a feasible method of design and development of different types of digital assets, an ARK-based switchboard has been used which has been thoroughly discussed in Appendix 5 and Appendix 17.4.

### **Content material presenter and activity tracking system**

To be able to track a learner's activity while navigating through course materials, a tracking system is being set up which records the learner's activities in the learning environment (LMS). The mechanism of this tracking system is different from other tracking systems which keep records of users' navigation through the e-learning system (web application). In the general tracking mechanism, the system uses operating system and browser details as part of the data store. However, in this new mechanism, the system will keep track of the learner's activities when s/he clicks on a link to open content material. In the future version of this system, this action would be performed through AJAX technology, so learners will not be distracted while a web page opens and closes through a small window in the web browser for the purpose of updating tracked records. A draft design of how content material is presented on the screen to the learner with the tracking link is included in Figure 27.

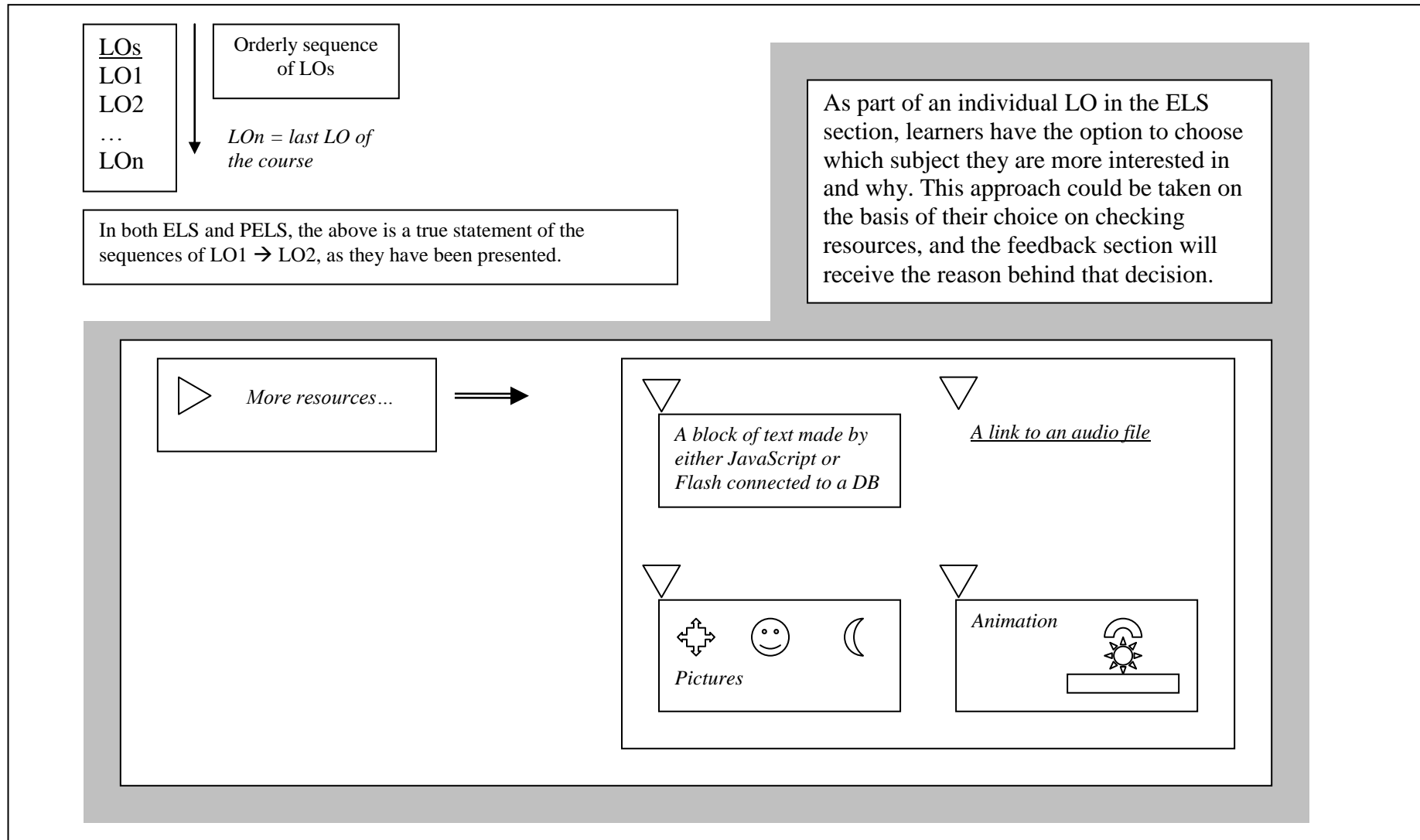


Figure 27: Content material presenter and activity tracking system.

## **5.4 ARK-based Switchboard, what it is and how it works**

In this section a need for a switchboard is discussed which addresses the need for having a simplified version of mass production of digital assets and learning objects. Subsequently, to investigate the hypothesis in section 2.8, the relationship between learners' learning preferences and their performance in both types of learning environment under study (a learning environment created with the use of adaptable and personalised e-learning systems) will be discussed.

### **5.4.1 What is an ARK-based Switchboard and its relevancy to this research?**

As the development of content material is the main part of any project in terms of time and effort, it is mandatory to seek an approach which considers content development from this point of view. But the main question is how to relate VARK-based types of variable with existing content development applications such as a presentation application (e.g. Microsoft PowerPoint – MS PowerPoint, 2002).

It is known that there are a variety of applications that could be used for this purpose, utilising either professional or basic tools. Whichever tool is used, their last product would fall on one of the categories based on VARK variables. So, it is possible to categorise those products based on basic or complex VARK variables. On the other hand, when it comes to developing content material, the last product should include combinations of those basic variables in order to deliver enough information to fulfil the requirements of an information package. For example, a picture (as a digital asset) could deliver some data but not enough to fulfil the requirements of a fully deliverable



information package which would be useful and can stand on its own without the need for any complex VARK from other data sources. This argument confirms that any “fully deliverable information package” should include a combination of those basic variables. This is to confirm a system known as an ARK-based switchboard.

**According to this switchboard, content developers will have a scale to refer to while developing content material.** So, while a learner completes the VARK-based tests at the beginning of the process of determining his/her knowledge and learning styles, an adaptable personalised e-learning system would convert the outcome to a suitable form with the use of an ARK-based switchboard. From now on, the system and content developer would work on the basis of an ARK type of content material.

***How an ARK-based switchboard works:*** as mentioned before, any content material would include combinations of the principal VARK-type variables (V, A, R, K, VA, ..., VARK). Besides, hypothesis one in section 1.3 requires an investigation for evidence on any relationship between types of e-learning systems and learners’ learning styles. As proven in Appendix 17, to prevent the design and development of 180 different types of digital asset for each content material, a new method is used which would justify the differences in terms of using existing technological methods but with the same learning philosophies. As such, there is a need to understand the different types of digital asset and how they could be developed (Table 8 below).

| NO | VARK types of DA | Full definition | How it would be used   | How it would be developed (applications are used as an example)        |
|----|------------------|-----------------|--|--|
| 1  | None             | None            | No form of any DA would be used  | Nothing to produce   |
| 2  | V                | Visual          | Just in the form of visual output (such as a photo, graph, animation, ...) | By using a photo editor application, video production tool, Flash, ... |
| 3  | A                | Audio           | Just in the form of audio output   | By using an audio production tool,                                     |

|   |    |                       |   |   |
|---|----|-----------------------|---|---|
|   |    |                       |   | microphone to record voices, a library of sound effects, ...  |
| 4 | R  | Read / Write          | Just in the form of Read or Write   | By using a text editor application such as MS Word, most of the other applications have this capability and it mostly depends on what other applications have been used   |
| 5 | K  | Kinaesthetic Tactile  | In the form of text entry in a form by using keyboard, moving objects in an animation developed by flash, ..., as this is mostly what would be used with other types of categories (VARK)   | This type of VARK would mostly be developed in relation to other types of VARK, as its main need within the category of HCI would be to interact with computers. Mostly Flash would be a good example of developing a kineasthetic type of Content Object |
| 6 | VA | Visual - Audio        | A visible person speaks about a picture, a video, an animation with moving objects around. The main concern here is that a voice must be included with a visual asset; the sound could be someone's voice, or sound effects   | Flash would be a good example on the list of developmental applications   |
| 7 | VR | Visual - Read / Write | In the form of a picture with a label or an explanation about the photo, or in the form of an animation with a label (caption) or movable text (e.g. by moving text above an icon and prompting using some text). Also, for Visual Write section it could be used to enter records or as an explanation of the system (this method is also partly kinaesthetic) | Flash is a simple application to develop such a combination. However, as described earlier, the best method is to generate such CO dynamically.   |
| 8 | VK | Visual - Kinaesthetic | An interactive animation is an example of such a Content Object   | Flash could be used to develop such CO  |
| 9 | AR | Audio - Read /        | AR: A block of text with a reader who explains the  | Either a text converter on the user's machine or  |

|    |     |                               |  |  |
|----|-----|-------------------------------|--|--|
|    |     | Write                         | contents of the text, including some additional explanations<br>AW: Although it is technically possible, it is a bit difficult to generalise it for all users, as it needs a specific configuration on the user's computer to be able to convert the user's voice to text, in the form of commands or normal text                  | pre-recorded contents would be used to develop this type of CO                                       |
| 10 | AK  | Audio - Kinaesthetic          | This combination could be used to develop CO for blind users, as the user could use either a keyboard, a special mouse or any other entry device to interact with the system   | The system should be able to accept entries from the user in the form of hardware mechanical devices |
| 11 | RK  | Read /Write - Kinaesthetic    | RK: this could be done by presenting text in the form of lots of navigation, or moving text-based presented objects<br><br>WK: Automatically typing text in a text-box on a form would fall into this category   | Flash would be a good example on the list of developmental applications                              |
| 12 | VAR | Visual – Audio – Read/Write   | VAR: when a picture or animation is presented it is necessary to have some text beside the contents including visual and audio effects<br><br>VAW: this process could fall into the category of receiving feedback from the user of the system, although this category would automatically include kinaesthetic to some degree too | Flash would be a good example on the list of developmental applications                              |
| 13 | VAK | Visual – Audio - Kinaesthetic | Again presenting digital assets in the form of moving objects, graphics would be most suitable for this category without the need for text (however, it is better to have at least a label to present these contents)  | Flash would be a good example on the list of developmental applications                              |
| 14 | VRK | Visual – Read / Write -       | VRK: in this category, there is no need to have audio within CO, as the user is probably   | Flash would be a good example on the list of developmental   |

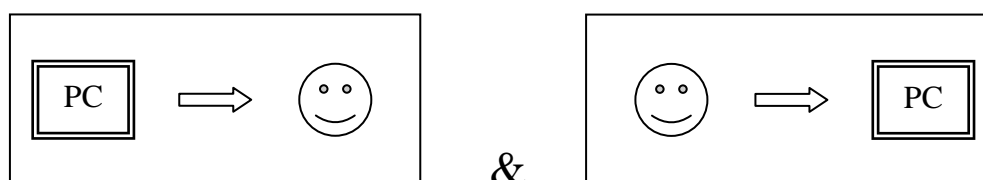
|    |      |  |   |  |
|----|------|--|---|--|
|    |      | Kinaesthetic   | more comfortable with a quiet environment<br><br>VWK: this method could be used to have users' feedback without the need for audio entries  | applications   |
| 15 | VAR  | Visual –<br>Audio –<br>Read /<br>Write                   | VAR: the user likes to have a graph or animation with some voices (a presenter voice and/or audio effects) and some text but without much interaction with its contents in the form of moving objects. However it could be counted in the form of a stabilised presentation without much physical activity<br><br>VAW: this form of CO could be used for receiving the user's feedback in the form of writing and no more physical interactivity. The writing section could be used to give command to the system for continuation or selection of a part of activities | Flash would be a good example on the list of developmental application |
| 16 | VARK | Visual –<br>Audio –<br>Read /<br>Write -<br>Kinaesthetic | This CO could be used for multi-modal people with a variety of input/output capabilities.<br>VARK: to receive information from the system by giving command to the system<br>VAWK: by giving feedback to the system for his specific needs and knowledge navigation   | Flash would be a good example on the list of developmental application |

**Table 8: Types and methods of creating Digital Assets**

**(i) Structure for converting ARK-based DAs from VARK-based DAs**

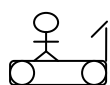
At the stage of (i) understanding the differences between different types of digital assets (Appendix 17), (ii) how they could be developed, and (iii) to find proof of relevancy between the different types of learning systems with the learner's learning

styles (section 2.8), the following analysis aims to look at the similarities and differences between the different types of digital assets and from both user-to-computer and computer-to-user perspectives (Figure 28).



**Figure 28: An illustration of two different perspectives of human-computer interaction.**

As mentioned in Appendix 17 section 5.3, the kinaesthetic type of interaction has a unique definition for its use. “K” or kinaesthetic means the computer should have a physical interaction with the user. This could be in the form of a treadmill:



which is controlled by a computer, and which controls its user’s movement, or the interaction of sound (made by a computer) with eardrums to transfer information to its receiver via a series of instructions or descriptions. In this project, only a voice (sound created by a computer) is used and not other machines like treadmills for transferring information to learners from the computer. So, “K” could be converted to the only available type of digital asset (from PC → Learner) of type “A” (Audio).

On the other hand from a User → Computer perspective, “A” (Audio) means changing the relationship between objects (as it is a physical interaction) ≡ Moving objects which means converting audio to video (A → V in User → PC).

Thus:

From PC  $\rightarrow$  Learner perspective: VK  $\rightarrow$  VA (learner receives from computer)

From Learner  $\rightarrow$  PC perspective: VK  $\rightarrow$  moving objects at the time of giving feedback (computer receives from learner).

To find the full list of conversions between digital assets, from the perspectives of learner to computer and vice versa, the following analysis is provided and all details and outcomes are gathered in Table 9 (below). However, to simplify this process the following explanation of the details of conversion would help us to gain an understanding of the process and the key elements in designing the table and they are listed below.

**Keys:**

ETB: Enterable Text Box

MO: Movable Objects (pictures or text boxes)

An ETB is used when a learner wants to send information to the computer, so a text box would be used for this purpose. MO on the other hand is used to give commands or send feedback to the computer via moving objects on the screen; it is known that in the Movable Objects method, the relationship between objects changes.

In Writing, “W” (writing to the computer would be translated into an ETB –editable text box), the relationship between the objects (the typed characters) is constant but the number of objects changes.

That’s why, for example, A  $\rightarrow$  V (MO) or audio type of digital assets could be replaced by a visual but in the form of a moving object while giving feedback to the

computer. This is because the learner can't talk to the computer while giving feedback and this decision was made based on the resources available to the learner.

Another important explanation regarding the use of  $K \rightarrow (V/W)$  (either MO/ETB) would be the kinaesthetic type of digital asset (which is only in the form of interaction with two other digital assets) converted to a visual or writing type of digital asset while giving feedback to the computer. This happens in the form of either moving objects (MO) or enterable text boxes (ETB).

### **(ii) State of each digital asset: static or dynamic**

The state which digital assets are in plays a fundamental factor in the process of identifying requirements on the definition of conversion-process, and they are: (i) dynamic and (ii) static states. These states formulate the methodology with which each digital asset can be designed and developed, and as such its combination with other types of digital asset would create a type of content material that would suit the required contents for diversity of learning, practice and assessment contents (section 4.5.1.1). For simplicity, the following abbreviations are used for these two states:

D: Dynamic

S: Static

The following table (Table 9 below) presents a list of all 15 types of digital assets (principal and combined digital assets) to find the rules on conversion processes. For example,  $[V: S/D \rightarrow S \rightarrow S+S \rightarrow V+R]$  in Table 9 means that two possible forms of picture exist – either static or dynamic types of picture – and to give the right expression, a reading type of digital asset should be included.

|    | PC → User |   | User → PC |  |
|----|-----------|---|-----------|--|
| 1  | V         | $S/D \rightarrow S \rightarrow S+S \rightarrow V+R$   | V         | ETB/MO<br>[It depends on the type of application which presents the V. If it is a movable type of picture then MO, if it is a type of enterable text box or even a clickable check box or radio button then ETB.<br>For the sake of simplicity and this project, ETB would be chosen whenever it is possible.] |
| 2  | A         | $D \rightarrow A$   | A         | MO [ $A \rightarrow V$ , because the relationship changes]   |
| 3  | R         | $S \rightarrow S+S \rightarrow R+V (\equiv V+R)$  | W (R)     | ETB [even choosing a radio button]   |
| 4  | K         | $D \rightarrow A$   | K         | MO / ETB   |
| 5  | VA        | $S/D+D \rightarrow [S \rightarrow \text{converts to D so:}] \rightarrow D+D \rightarrow VA$ | VA        | MO<br>[ETB/MO+MO $\rightarrow$ MO]   |
| 6  | VR        | $S+S \rightarrow V+R$   | VR        | ETB<br>[ETB/MO+ETB $\rightarrow$ ETB]  |
| 7  | VK        | $S/D+D \rightarrow D+D \rightarrow V+K \equiv V+A \equiv VA$                                | VK        | ETB<br>[ETB/MO+ETB/MO $\rightarrow$ ETB]   |
| 8  | AR        | $D+S \rightarrow A+R \rightarrow A+V \rightarrow D+S/D \rightarrow D+S \rightarrow VA$      | AR        | ETB*<br>[MO+ETB $\rightarrow$ ETB]   |
| 9  | AK        | $D+D \rightarrow A+A \equiv A$  | AK        | MO<br>[MO+MO/ETB $\rightarrow$ MO]   |
| 10 | RK        | $S+D \rightarrow R+K \equiv R+A \equiv RA \equiv AR \rightarrow VA$                         | RK        | ETB<br>[ETB+ETB/MO $\rightarrow$ ETB]  |
| 11 | VAR       | $S/D+D+S \rightarrow V+A+R \equiv V+A \equiv VA$  | VAR       | ETB*<br>[ETB/MO+MO+ETB $\rightarrow$ ETB]  |
| 12 | VAK       | $S/D+D+D \rightarrow VA+K \equiv VA+A \equiv VA$  | VAK       | MO<br>[ETB/MO+MO+ETB/MO $\rightarrow$ MO]  |
| 13 | VRK       | $S/D+S+D \rightarrow VR + K \equiv V + A \equiv VA$   | VRK       | ETB<br>[ETB/MO+ETB+ETB/MO $\rightarrow$ ETB]   |
| 14 | ARK       | $D+S+D \rightarrow D+S \rightarrow AR+A \equiv AR \equiv VA$                                | ARK       | ETB*<br>[MO+ETB+ETB/MO $\rightarrow$ ETB]  |
| 15 | VARK      | $S/D+D+S+D \rightarrow S/D+D+S \rightarrow V+A+R+A \equiv VAR \rightarrow VA$               | VARK      | ETB*<br>[ETB/MO+MO+ETB+ETB/MO $\rightarrow$ ETB]   |

**Table 9: DAC: Digital Asset Conversion**

\* From the learner-to-computer perspective, the action towards doing ETB has the priority over the necessary action towards MO, because a user needs to click on an



object before dragging it. So when it comes to choosing between MO or ETB, the option would be ETB. The same goes for the MO+ETB case because, principally, MO could be counted as ETB and then a dragging process, so:

$$MO + ETB \equiv (MO/ETB) + ETB \equiv (ETB) + ETB \equiv ETB.$$

The simplified version of Table 9 is as below (Table 10), which is another step closer to finding the most suitable and efficient way of converting digital assets into other formats. It will be known as an ARK-based switchboard from now on. The ARK-based switchboard is used to convert the concept of design and development of digital assets into a suitable format which would be used by AAPELS and would be easy to work with for its users.

|    | PC → User |  | User → PC |          |
|----|-----------|--|-----------|----------|
| 1  | V         | V+R as long as it is static  | V         | ETB/MO   |
| 2  | A         | A (plus R as link and V)   | A         | MO       |
| 3  | R         | R+V ( $\equiv$ V+R)  | W (R)     | ETB      |
| 4  | K         | A  | K         | MO / ETB |
| 5  | VA        | VA (video + audio commentary)  | VA        | MO       |
| 6  | VR        | Text with picture (R + Static V)   | VR        | ETB      |
| 7  | VK        | V+K $\equiv$ V+A $\equiv$ VA,<br>Physical interaction  | VK        | ETB      |
| 8  | AR        | D+S → A+R → A+V<br>→ D+S/D → D+D →<br>VA (static text with<br>short sentences and<br>pictures + audio<br>commentary)                 | AR        | ETB      |
| 9  | AK        | A+A $\equiv$ A (Link as text<br>R)   | AK        | MO       |
| 10 | RK        | R+K $\equiv$ R+A $\equiv$ RA $\equiv$<br>AR<br>R+K $\equiv$ R+A $\equiv$ RA $\equiv$<br>AR → VA (but with<br>static short sentences) | RK        | ETB      |
| 11 | VAR       | V+A+R $\equiv$ V+A $\equiv$ VA,<br>Static short sentences of   | VAR       | ETB      |

|    |      |  |      |     |
|----|------|--|------|-----|
|    |      | text would act as pictures, text with pictures + audio commentary                                  |      |     |
| 12 | VAK  | $VA+K \equiv VA+A \equiv VA$<br>(dynamic pictures/video + audio commentary)                        | VAK  | MO  |
| 13 | VRK  | $VR + K \equiv V + A \equiv VA$ ,<br>Static short sentences of R would act as V + audio commentary | VRK  | ETB |
| 14 | ARK  | $AR+A \equiv AR \equiv VA$<br>(static short sentences with audio commentary)                       | ARK  | ETB |
| 15 | VARK | $V+A+R+A \equiv VAR \rightarrow VA$ (static short sentences + studio commentary)                   | VARK | ETB |

**Table 10: Table DAC2: Simplifying the conversion process of digital assets into a principal format of ARK-based switchboard.**

As “K” means:

- Changes in relationship (such as MO – Moving Object)
- Changes in the number of objects (Writing  $\equiv$  adding characters) but not in their relationship

This means the second and the third group could fall into two main factors – input and output tools in the interaction between human and computer – and either from the computer perspective or otherwise.

As discussed in Appendix 17 section 4.1 which is on types of content material (learning content – LC, practice content – PC and assessment content – AC), the compatibility of those types of content material can be analysed further as shown in the following section.

**(iii) Combinations of digital assets**

Let's continue on the basis of the above categorisation and look at them from the learner's perspective. The possible outcomes for each are as follows:

- a) Compatible format of Learning Contents – Input – would be: V, A, R (not W), VA, VR (not VW), AR (not AW), VAR (not VAW)
- b) Compatible format of Practice and Assess – Input – would be: V, A, R (not W), VA, VR (not VW), AR (not AW), VAR (not VAW)
- c) Compatible formats of Practice and Assess – Output – would be: K, WK (not RK)

In other words, Learning Content (LC) related contexts cannot be one of the principal types of digital asset (only V-video, A-audio, R-reading and K-kinaesthetic) and should have descriptions (for example, learning content with just animation, or a video streaming without a label or audio commentary wouldn't be called learning content). So this clarifies the main need to have a combination of DAs (Digital Assets).

LC: VA, VR, AR, VAR

The options available to develop learning content would be in the form of a series of combinations of VA (video and narrated audio effects), VR (video with reading materials), AR (audio and reading materials) and VAR (video which includes narrated audio effects and reading materials). All the above content must include either static or dynamic types of content. The same goes for PC (Practice Content) and AC (Assessment Content) as follows:

**Available options to give inputs to the user from the computer:**

PC – input: VA, VR, AR, VAR

AC – input: VA, VR, AR, VAR

**Available options to pass outputs from the user to the computer:**

PC – output: WK

AC – output: WK

Other types – such as visual, auditory and kinaesthetic types of digital interaction – would not be feasible and some are only available in the form of research. An example of this would be a process that enables a learner to transfer visual effects into the machine so that it can read the message.

The above analysis has identified methods for creating learning content using available combinations (and that goes for Practice and Assessment content, too). This means that when digital assets are created, they should be linked with their related format for the production phase of content development. Full descriptions of these relationships are in Table 11, but a few examples on the relationship between individual DAs are as follows:

**Input from computer to user:**

i)  $V \Rightarrow A, R, AR$

ii)  $A \Rightarrow R, V, VR$

iii)  $R \Rightarrow V, A, VA$

i) This means that if any V is created, the available options to link other digital assets should be in the form of either A, R or AR; the same goes for (ii) A and (iii) R as above. For giving feedback to the computer, the available options would be:

**Output from user to computer:**

W =&gt; K

K =&gt; W

The following table (Table 11) gives all available options while designing and developing combined forms of principal digital asset.

|          |   |
|----------|---|
| V => A:  | Any picture or animation must include an audio DA (Digital Asset)   |
| V => R:  | Any picture or animation must include a piece of text (DA) such as a caption  |
| V => AR: | Any picture or animation must include a piece of text (DA) such as a caption and audio (e.g. audio effect, presenter, story teller, ...)  |
| A => R:  | Any audio DA must include a piece of text, such as a label or caption   |
| A => V:  | Any audio DA must include a picture or animation  |
| A => VR: | Any audio DA must include a visual and textual DA   |
| R => V:  | Any piece of text must include a visual DA  |
| R => A:  | Any piece of text must include an audio DA  |
| R => VA: | Any piece of text must include a visual and audio DA  |
| W => K:  | Any piece of text must be accepted kinaesthetically, and it is mostly via keyboard  |
| K => W:  | Any kinaesthetic activity must be accepted via keyboard in the form of a text entry   |
| K:       | Any individual kinaesthetic type of activity must be via a mouse and must be used on moving visual objects on the screen. However, this format must be supported by a visual or textual type of DA. * |

\* *This topic has been fully investigated in section 17.5.3 of Appendix 17.*

**Table 11: This table presents the type of digital asset each one should be linked to and the reason behind it.**

Regarding the individually-made K type of DA, as mentioned earlier, it must relate to other DAs. However, there is a need that arises at the time of the developing phase, which means that while a DA of type K is under development, the other types of DA that would be involved for the next step of development should be mentioned. This process happens in the content object (CO) phase.

There is a set of rules on converting all types of VARK-based digital asset into an ARK-based form of digital asset in Table 12 (below).

| Conversion switchboard of VARK-based digital assets into ARK-based types of digital assets |                  |           |       |                       |    |    |   |              |
|--|------------------|-----------|-------|-----------------------|----|----|---|--------------|
| VARK-based Analysis  |                  |           |       | ARK-based Switchboard |    |    |   |              |
| VARK category  | Pc → User        | User → PC | Notes | A                     | RT | RS | K | ARK category |
| V  | R <sub>SP</sub>  | ETB       |       | 0                     | 0  | 1  | 1 | KRS          |
| A  | AR <sub>DP</sub> | MO        |       | 1                     | 0  | 0  | 1 | AKRD         |
| R  | R <sub>SP</sub>  | ETB       |       | 0                     | 0  | 1  | 1 | KRS          |
| K  | AR <sub>SP</sub> | ETB       |       | 1                     | 0  | 1  | 1 | AKRS         |
| VA   | AR <sub>DP</sub> | MO        |       | 1                     | 0  | 0  | 1 | AKRD         |
| VR   | R <sub>SP</sub>  | ETB       |       | 0                     | 0  | 1  | 1 | KRS          |
| VK   | AR <sub>DP</sub> | ETB       |       | 1                     | 0  | 0  | 1 | AKRD         |
| AR   | AR <sub>ST</sub> | ETB       |       | 1                     | 1  | 1  | 1 | AKRS         |
| AK   | AR <sub>SP</sub> | MO/ETB    | *     | 1                     | 0  | 0  | 1 | AKRD         |
| RK   | AR <sub>ST</sub> | ETB       |       | 1                     | 1  | 1  | 1 | AKRS         |
| VAR  | AR <sub>DT</sub> | ETB       |       | 1                     | 1  | 0  | 1 | AKRD         |
| VAK  | AR <sub>DP</sub> | MO        |       | 1                     | 0  | 0  | 1 | AKRD         |
| VRK  | AR <sub>DP</sub> | ETB       |       | 1                     | 0  | 0  | 1 | AKRD         |
| ARK  | AR <sub>ST</sub> | ETB       |       | 1                     | 1  | 1  | 1 | AKRS         |
| VARK   | AR <sub>DT</sub> | ETB       |       | 1                     | 1  | 0  | 1 | AKRD         |
|  |                  |           |       |                       |    |    |   |              |

**Keys:**

\* A → K+V(R)

A: Audio included

K on VARK-based Analysis system: Kinaesthetic/Tactile based Digital Asset

K on ARK-based switchboard: Interaction included

RS: Static type of contents materials

RD: Dynamic type of content materials

ETB: Enterable Text Box

MO: Moveable Object

P as subscript: Pictures

T as subscript: Text

**Table 12: ARK-based switchboard**

**Note:** Because in principle both “text” and “picture” are the same, as they are “shapes”, in this process both are counted the same. Thus:  $RP = RT$  or  $R_P = R_T$  [the Reading material of type Picture is the same as the Reading material of type Text].

**Note:** As is shown, all types of content material are included with interaction (K – Kinaesthetic type), because of the use of a specific type of Flash producer (Macromedia Breeze). The outcome of this application is a type of content material, and buttons are used for its navigation through materials in the form of a series of slides. This means that for the minimum amount of interaction the action of clicking

on a button will be used for its interactivity. In this respect the outcome of the switchboard is in the form of three different types of content material:

KRS (Kinaesthetic and static type of reading materials), AKRS (Kinaesthetic and static type of reading materials with audio included), AKRD (Kinaesthetic and dynamic type of reading materials with audio included).

Now if the element of kinaesthetic be converted into the form of activity or interaction, there are 6 different types of content material from (i) KRS, (ii) AKRS and (iii) AKRD as discussed in the previous paragraph, thus:

$RS_P$ ,  $ARD_P$ ,  $ARS_P$ ,  $RS_T$ ,  $ARD_T$ ,  $ARS_T$  and they are:

- i.  $RS_P$ : Static form of reading materials in the form of pictures
- ii.  $ARD_P$ : Dynamic form of reading materials in the form of pictures with audio included
- iii.  $ARS_P$ : Static form of reading materials in the form of pictures with audio included
- iv.  $RS_T$ : Static form of reading materials in the form of text
- v.  $ARD_T$ : Dynamic form of reading materials in the form of text with audio included
- vi.  $ARS_T$ : Static form of reading materials in the form of text with audio included

In addition to the above categorisation, there are a few similarities between the properties of those types of content:

- Static reading materials in the form of pictures is the same as reading materials in the form of text:  $RS_P \equiv RS_T$ . The reason is (as proven in Appendix 17 section 5.2) that a character is, in principle, a type of picture.
- Dynamic reading materials in the form of pictures with audio are the same as dynamic reading materials in the form of text with audio:  $ARD_P \equiv ARD_T$ .

- Static reading materials in the form of pictures with audio are the same as static reading materials in the form of text with audio:  $ARS_P \equiv ARS_T$ .

The above comparison results in three different types of content material, which could be named as principal formats of digital assets on the basis of an ARK-based switchboard:

RS, ARD, ARS

As these acronyms stand for:

RS: Reading materials with a static type of content

ARD: Reading materials with dynamic content and audio included

ARS: Reading materials with static content and audio included

### **Conclusion of this section**

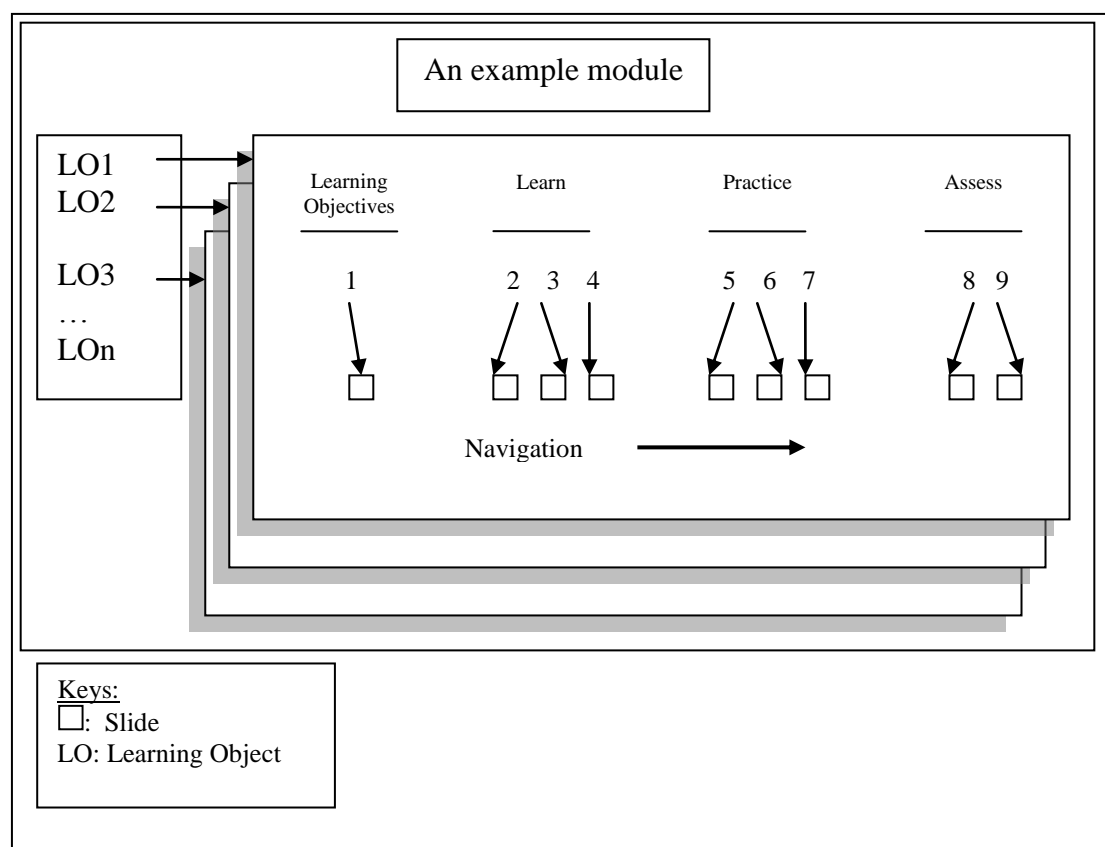
The above sections show that it is more feasible to design and develop three major types of content material ( $R_S$ ,  $AR_D$  and  $AR_S$ ), with or without interaction between their contents, than design and develop 15 different types of content materials for each section of learning content (LC – with one section of scenario), practice content (PC – with three categories of context in the form of: (i) scenario, (ii) questions, and (iii) explanation) and assessment content (AC – with two types of context: (i) scenario, and (ii) questions). The ARK-based switchboard has provided a framework for the best possible and most feasible method of designing and developing content which would support the type of data to be gathered for finding any relationship between learners' learning preferences and types of e-learning systems (adaptable and personalised e-learning systems). In addition to this conclusion, this switchboard in turn brings the measure of learner control into the system and gives a well defined control over the learning environment to either the learner or the system to determine the content produced for the learning environment.



### **5.4.2 Learning objects and ARK-based content material**

In the previous section (5.4.1), it was argued that the framework for the design and development of any content material based on ARK switchboard would have the same concept of delivery of knowledge as a VARK-based type of content. As such, any individual form of designed and developed content object (CO) with a specific objective towards fulfilling a part of a module would be presented in the form of a package known as a learning object (Appendix 17 – section 3.2), which is a collection of learning, practice and assessment materials.

An overview of the structure of a navigational map for a module with the support of learning objects is given in Figure 29. It includes the relationship between the content material of type learning, practice and assessment categories of scenario, question and explanation form of contexts (detailed structures based on VARK- and ARK-based switchboards are in Figure 30 and Figure 31).



**Figure 29: Detailed structure of a module (for example) navigation with the support of Learning Objects.**

Whilst there are many different structures that exist for the definition and relationship between programs, courses, lessons, class sessions etc, Figure 29 presents a high-level overview of a class session with relevant learning objects which are made up of a collection of learning objectives, learning materials, practice materials and assessment materials, and all four of these sections are bounded by metadata which makes it a suitable format for creating a learning object package to be compatible with other types of e-learning system.

The sketches presented in Figure 30 and Figure 31 give navigational options to learners to access relevant course materials which have been decided by their learning preferences. The design would also give the instructional designer and system developer a set of frameworks to be able to design an online learning system, with the navigation through course materials grouped into a package known as Learning

Objects. Each learning object should be able to present eight different types of content material analysed and designed based on ARK categorisation.

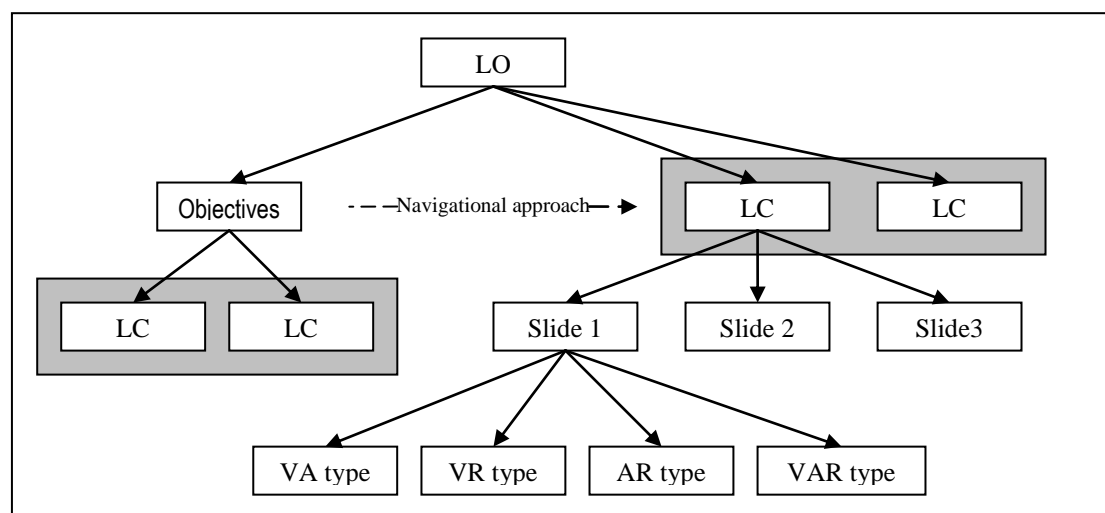


Figure 30: Figure LOLC: Learning Object and Content Material based on VARK

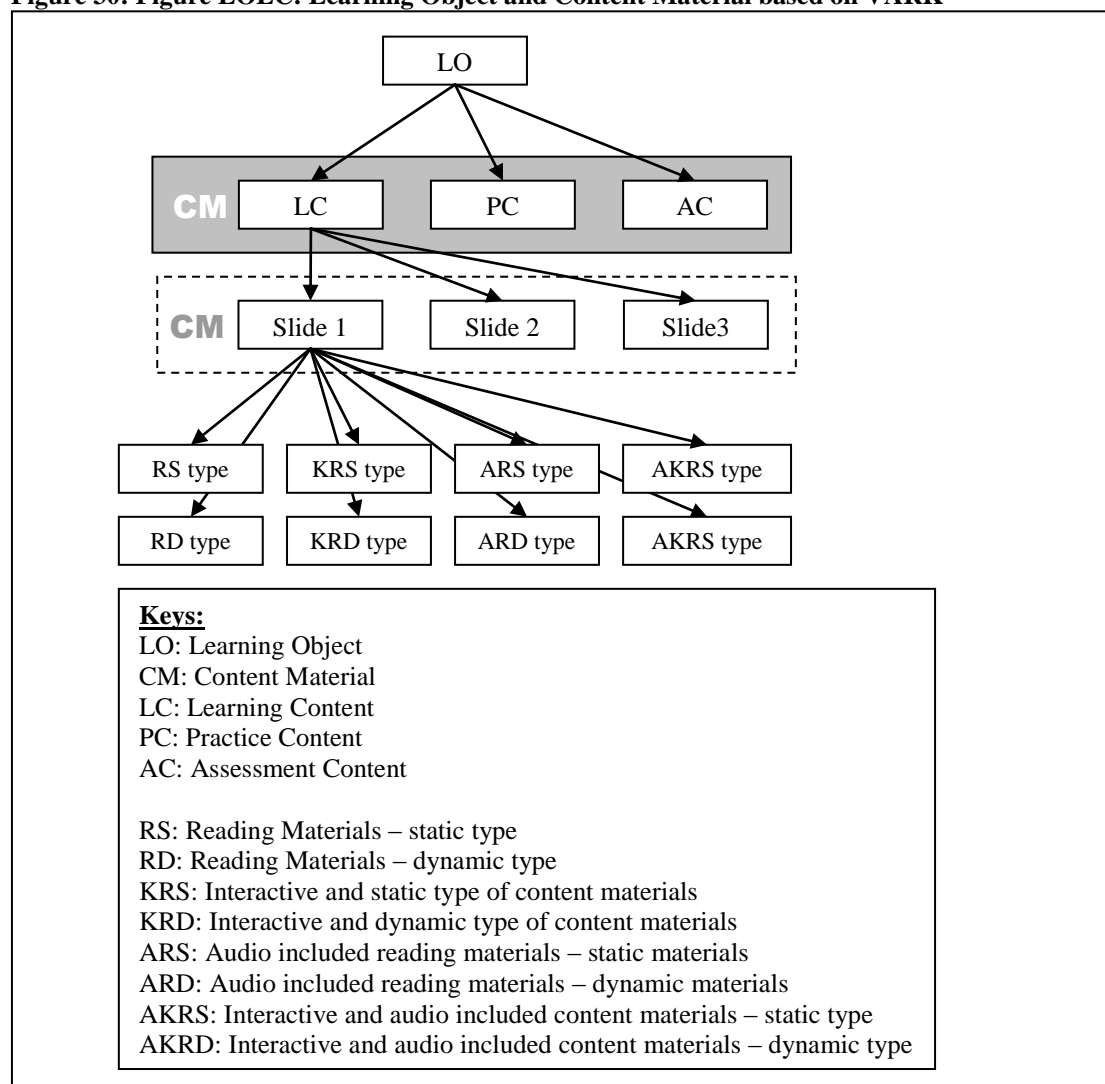


Figure 31: Figure LO-ARK: Learning Object and Content Material based on ARK

## 5.5 Designing assessment materials for measuring learners' learning performance

Following the discussion presented in sections 2.4 and 4.9, it seemed necessary to design a lower level of assessment questions based on the i) basic, ii) procedural, and iii) conceptual types of knowledge a learner holds. These questions would be in the form of recalling, competency and understanding types of assessment questions. Furthermore, those questions are used in the form of whether practice or assessment content in a learning object (LO); besides each learning object (as discussed in sections 5.4.2 and Appendix 17) are a collection of i) Scenario, ii) Questions and iii) Explanation for practice contents and no explanation for assessment contents, since this is the assessment time and no explanation is given during such times.

|                              |                         |                                  |                                  |                                    |
|------------------------------|-------------------------|----------------------------------|----------------------------------|------------------------------------|
| <b>LO</b><br>Learning Object |                         | <b>LC</b><br>Learning<br>Content | <b>PC</b><br>Practice<br>Content | <b>AC</b><br>Assessment<br>Content |
|                              | <b>S</b><br>Scenario    | <b>CM</b><br>Content<br>Material | <b>CM</b><br>Content<br>Material | <b>CM</b><br>Content<br>Material   |
|                              | <b>Q</b><br>Query       | ---                              | <b>CM</b><br>Content<br>Material | <b>CM</b><br>Content<br>Material   |
|                              | <b>E</b><br>Explanation | ---                              | <b>CM</b><br>Content<br>Material | ---                                |

Figure 32: A detailed version of a semi-standard version of a learning object (LO)

Learners' activities in answering those questions are tracked down via an optional questions type of assessment. This approach is selected because of the technology at

hand and the data gathered from those activities are directly stored in a database.

Thus, the design of these questions is based on the following structure:

i) A recalling (R) type of question should be designed in such a way that will lead to a question and four answers. One answer is correct and the learner's answer will be stored in the relevant database.

ii) A competency (C) type of question is similar to the recalling type of question; however, there are a series of additional complementary documents added to each question. This is done so that learners have to work on those documents (whether they include an instruction to do a certain task or whether it has already been added in the question itself) and then they should choose one of the given answers.

iii) The design of an understanding (U) type of question is slightly different, and it is enclosed in the conceptual type of knowledge so that the question is designed to evaluate the knowledge of its holder (the learner) on a topic of that type. To solve this issue, there will be four different possible answers designed and added to each optional answer, for each question. The learner should therefore have understood the question and then s/he is able to select the correct answer.

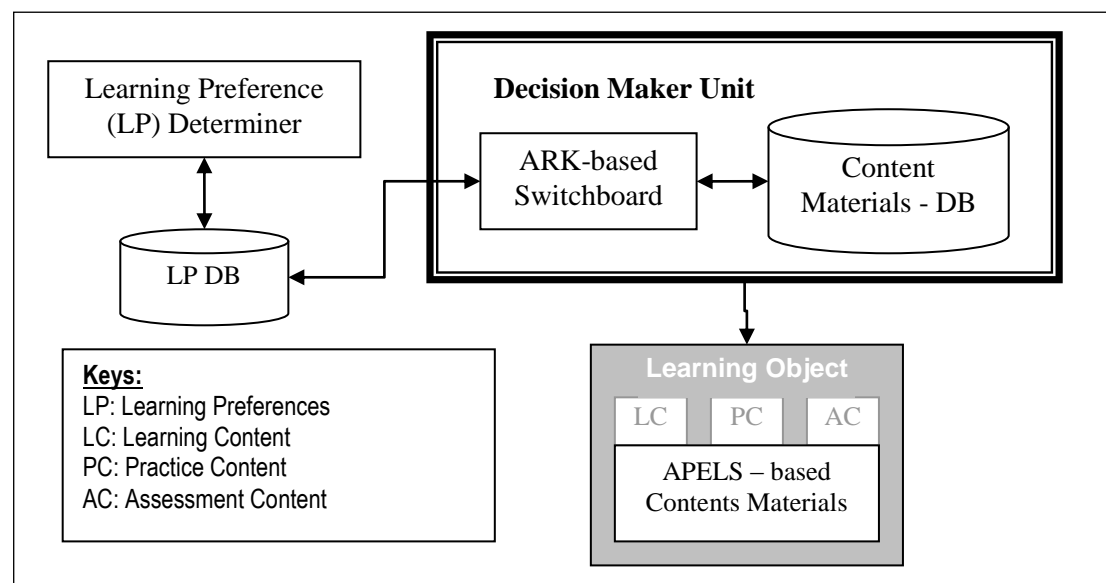
## **5.6 Implementation of adaptable and personalised**

### **ELS**

To seek proof of the hypothesis that this research is based upon (section 2.8), which is the study of the effectiveness of adaptable personalised e-learning systems on learners' learning performance, a unique system called A<sub>L</sub>PELS (adaptable personalised e-learning system) was designed and developed in such a way that learners' interaction with the system can be tracked and stored in a database. All documentation of collected data is included in appendices in the production log. It is the aim of this research to investigate the effects of the types of assessment questions (recall, competency and understanding) in different environments of e-learning systems (adaptable and personalised e-learning systems to be specific) and how they related to learners' learning performance.

Learners would start by gaining access to the system via a self-registration process. After three short assessments of a) Learning Preference Determiner (VARK-based, includes 13 questions), b) General IT knowledge assessment (includes 10 questions) and c) Self assessment (included 6 questions), learners have access to the content material. It is necessary to mention that the outcome of "self assessment" questions was ignored because at this stage of the research it was considered irrelevant. A<sub>L</sub>PELS puts learners into one of two groups, at the time of registration (section 5.3). They are A<sub>L</sub>ELS and PELS (adaptable and personalised e-learning systems). The A<sub>L</sub>ELS is a group in which its learners are able to change their selected LP (learning preferences) in the system via a user interface during the course and PELS are those who are not able to do that. The second group is specifically categorised to study the

difference between decision makers: “learner-centric and machine-centric”. The A<sub>L</sub>ELS group has a learner-based decision maker for choosing course materials and PEELS has a machine-based principle. The basic idea behind A<sub>L</sub>PELS is shown in Figure 33:



**Figure 33: A high-level design view of an Adaptable Personalised E-Learning System (A<sub>L</sub>PELS)**

Following the initial tests of the system, the A<sub>L</sub>PELS was made available to the MSc students in their MSc Computing and Information Systems program. These students generally have little or no background in computing. It is acknowledged that as a result of time pressure (as the MSc students were required to go through the learning material quickly), it was felt that training was unnecessary for the students and effectively they were asked to register and work through the materials on their own. As the system contained the necessary information for learners to start with in terms of navigating through the system, continuously receiving reports on their activities and having the option to get in touch with their tutor, learners would get the sense of being in a classroom with their tutor and so their learning outcomes in terms of using e-learning system would not be affected.

## **5.7 Conclusion**

The need for an ARK-based switchboard, as a facilitator in the process of digital assets designed based on VARK and how to be understood by an ARK-based adaptable and personalised e-learning system (AAPELS), was discussed as a mandatory step in the process of investigating the effectiveness of AAPELS on education. In terms of instructional methods, the design and development phases discussed in this chapter provide an environment where learners' activities can be tracked while interacting with a learning environment developed based on a learner-centred learning environment. This chapter also includes the implementation phase of the project so to investigate the evidence for proof or disproof of hypothesis in section 2.8, which is the effectiveness of learners' learning preferences in different learning environment in terms of their learning performance.



## **Chapter 6      Experimental Design and Data Evaluation**

### **6.1 Overview**

This chapter presents the process of data collection, analysis and findings of gathered data in relation to learners' learning styles and their performance while interacting with different types of e-learning systems. This chapter is a combination of 3 sections: (i) data collection and methodology for data analysis, (ii) data analysis and findings, and (iii) conclusion.

### **6.2 Data Collection and methodology of data analysis**

This is a two part data analysis to find if any correlation exists between learners' interaction with the system, the type of e-learning systems and learning preference-based content materials. The first part of data analysis (section 6.3) is done solely based on the duration of learners' activities on learning materials. Based on the study done in section 2.5.3 the type and the timing of learners interaction with content materials would be an effective factor on the categorisation of learner's learning performance. The second part of the data analysis (section 6.4) categorises learners based on the type of assessment questions they have attempted.

### **6.3 Data Analysis and Finding – categorisation of learners outcome based on the duration of their activities**

Analysis of data on learner's performance based on different types of content materials and e-learning systems:

- i) Data Analysis and Findings on Learners' Performance based on their learning preferences and VARK- & ARK-based content materials
- ii) Data Analysis and Finding on learners' performance based on A<sub>L</sub>ELS and PELS

#### **6.3.1 Data Analysis and Findings on Learners' Performance based on their learning preferences and VARK- & ARK-based content materials**

In this section data gathered from learner's activities on finding the existence of any relationship between VARK- & ARK-based content materials and their performance will be analysed.

##### **6.3.1.1 Methodology used on data analysis**

There are three statistical methods of *t*, *f* and Chi-squared tests used to analyse the outcome from learner's interaction with the system. As it is known the *t*-test is the most commonly used method to evaluate the differences in means between two groups. For example, the *t*-test can be used to test for a difference in test scores between groups of patients who were given either drug or received placebo. (StatSoft, 2008). Frequency of data represents the simplest method of analyzing categorical data. This method is often used to review how different categories of values are distributed in the sample.

As mentioned earlier, by the use of F-table, T-table, the minimum average and probability of 5% levels of distribution, outcome of their duration of involvement with the system (time spent on the interaction with the system) indicates that learners can be divided into more than one group (screen capture of the database analysis can be found in appendices 3 and 4 in the production log of the thesis).

1% → 17 groups

5% → 11 groups

10% → 9 groups

The probability of 5% levels of distribution is chosen (as it is used as a commonly practised value – (StatSoft (2010))) to put those learners involved with the project into different groups. Following (Table 13) is the list of grouped AAPELS users and identified by their User ID. For example, under G1 column (G1 stands for “group one”), the number “188” is the user ID of a learner.

| G1  | G2  | G3  | G4  | G5  | G6  | G7  | G8  | G9  | G10 | G11 |
|-----|-----|-----|-----|-----|-----|-----|-----|-----|-----|-----|
| 188 | 99  | 149 | 100 | 326 | 184 | 91  | 343 | 174 | 291 | 217 |
| 327 | 276 | 236 | 153 | 132 | 268 | 135 |     |     | 115 | 317 |
| 269 | 134 | 81  |     |     | 254 | 143 |     |     | 150 | 277 |
| 352 | 221 |     |     |     | 87  | 124 |     |     | 226 | 401 |
| 117 | 357 |     |     |     | 89  | 332 |     |     | 76  | 337 |
| 334 | 282 |     |     |     |     | 305 |     |     |     | 330 |
| 342 | 142 |     |     |     |     | 86  |     |     |     | 237 |
| 389 | 152 |     |     |     |     | 129 |     |     |     | 154 |
| 125 | 101 |     |     |     |     | 196 |     |     |     | 195 |
| 169 | 145 |     |     |     |     | 126 |     |     |     | 329 |
|     | 302 |     |     |     |     | 83  |     |     |     |     |
|     | 313 |     |     |     |     |     |     |     |     |     |
|     |     |     |     |     |     |     |     |     |     |     |
|     |     |     |     |     |     |     |     |     |     |     |

**Table 13: List of learners grouped by their activity time spend on each topic**

Based on the time spent on each topic (AC – assessment contents – related) and number of learners in each group, effects of interaction between learners within the

system for only first seven groups are studied. The reason being is that the time spent on assessment contents related category of learning objects are trivial which could be ignored. Thus, by categorising those groups into different types of ELSs the outcome is presented in Table 14:

| G1    | ELS-type | G2  | ELS-type | G3  | ELS-type | G4  | ELS-type | G5  | ELS-type | G6  | ELS-type | G7  | ELS-type |        |
|-------|----------|-----|----------|-----|----------|-----|----------|-----|----------|-----|----------|-----|----------|--------|
| 188   | ELS      | 99  | PELS     | 149 | ELS      | 100 | ELS      | 326 | PELS     | 184 | ELS      | 91  | ELS      |        |
| 327   | ELS      | 276 | ELS      | 236 | ELS      | 153 | PELS     | 132 | PELS     | 268 | ELS      | 135 | PELS     |        |
| 269   | PELS     | 134 | ELS      | 81  | PELS     |     |          |     |          | 254 | ELS      | 143 | ELS      |        |
| 352   | PELS     | 221 | ELS      |     |          |     |          |     |          | 87  | PELS     | 124 | ELS      |        |
| 117   | PELS     | 357 | ELS      |     |          |     |          |     |          | 89  | ELS      | 332 | PELS     |        |
| 334   | PELS     | 282 | ELS      |     |          |     |          |     |          |     |          | 305 | ELS      |        |
| 342   | PELS     | 142 | ELS      |     |          |     |          |     |          |     |          | 86  | ELS      |        |
| 389   | ELS      | 152 | ELS      |     |          |     |          |     |          |     |          | 129 | PELS     |        |
| 125   | ELS      | 101 | ELS      |     |          |     |          |     |          |     |          | 196 | ELS      |        |
| 169   | ELS      | 145 | ELS      |     |          |     |          |     |          |     |          | 126 | PELS     |        |
|       |          | 302 | PELS     |     |          |     |          |     |          |     |          | 83  | ELS      |        |
|       |          | 313 | ELS      |     |          |     |          |     |          |     |          |     |          |        |
|       |          |     |          |     |          |     |          |     |          |     |          |     |          | Totals |
| ELS   | 5        |     | 10       |     | 2        |     | 1        |     | 0        |     | 4        |     | 7        | 29     |
| PELS  | 5        |     | 2        |     | 1        |     | 1        |     | 2        |     | 1        |     | 4        | 16     |
| Total | 10       |     | 12       |     | 3        |     | 2        |     | 2        |     | 5        |     | 11       | 45     |

**Table 14: List of groups of learners divided into different types of e-learning systems**

There are screenshots of spreadsheet-based data analysis provided in the production log.

Our early evaluation of the data gives some tentative indications about learners learning style and performance. This could also be interpreted as learners' performance and the type of learning content they used. These indications could be summarised as follows:

Learners with "V-A-R-K" learning style (using the VARK type learning contents show better performance than other groups and show advancements on their learning performance by doing better on their assessments. Also within this group there is a significant difference between the result of those who took the test before going through the learning content and those who took the test after going through the learning contents (53% to 33%). Also learners using content materials of type "RS – static type of reading materials", "AKRS – static type of reading materials with

interactive contents which includes audio” and “AKRD – dynamic type of reading materials with interactive contents which includes audio” shown improvement on their performance based on their assessment results.

Like many other educational technologists, there is a cautious approach regarding the whole concept of determining learners learning styles, nevertheless, this project has clearly shown that it is possible to develop systems that allow users to have a direct input in terms of the type and delivery of their learning material. Furthermore the data also shows that the personalisation in the cases of people with the VARK (which contains the largest variety of learning content material) improves learners’ performance.

### 6.3.1.2 Results of learners' activities based on their learning

#### preferences and VARK- & ARK-based course materials

During the period of the course when the system was accessible, 71 learners accessed APELS, 59 learners took the VARK test and determined their LP and 37 of those learners attempted practice and assessment section of content materials. The outcome of the last experience indicated that learners who are able to change their LP, have shown 5% increase in their learning performance. Details are in Table 15-1 and Table 15-2 (Table 15).

| Relationship between Assessment Performance & Learning Preferences |                     |      |            | Relationship between Assessment Performance & ARK based contents materials |                     |      |            |
|--|---------------------|------|------------|--|---------------------|------|------------|
|  | LP/Main Grand Total |      |            |  | LP/Main Grand Total |      |            |
|  | UP                  | DOWN | No attempt |  | UP                  | DOWN | No attempt |
| V  |                     | 5%   |            | RS   | 3%                  |      |            |
| A  |                     | 3%   |            | RD   |                     | 3%   |            |
| R  | 8%                  | 3%   | 5%         | ARS  |                     |      |            |
| K  | 5%                  |      |            | ARD  |                     | 3%   |            |
| VK   |                     | 3%   |            | KRS  | 8%                  | 8%   | 5%         |
| AR   | 3%                  | 3%   |            | KRD  |                     |      | 3%         |
| RK   |                     | 5%   |            | AKRS   | 5%                  | 3%   |            |
| VRK  | 5%                  | 5%   | 3%         | AKRD   | 30%                 | 24%  | 5%         |
| VARK   | 24%                 | 14%  | 5%         | Subtotal:  | 46%                 | 41%  | 14%        |
| Subtotal:  | 46%                 | 41%  | 14%        | Total:   |                     |      | 100%       |
| Total:   |                     |      | 100%       |  |                     |      |            |

Table 15-1: Assessment Performance and LP

Table 15-2: Assessment Performance and ARK-based contents materials

**Table 15: outcome of relationship between assessment performance on the base of learning preferences and ARK-based content materials**

However, as a short comment it can be said that Table 15-1 shows that learners with a learning style of VARK demonstrated a 24% increase in learning performance. However, based on Table 15-2 the AKRD materials which were provided to VARK students, showed an increase in learning performance of 30%. The reason for the difference is that AKRD materials were provided to students with learning styles

other than VARK i.e. there isn't a one to one correlation between the learning style and the materials used.

### **6.3.1.3 Discussion of findings**

On the base of findings from above outcome, following two conclusions are made:

A) By the use of F-table, T-table, the minimum average and probability of 5% level of distribution, outcome indicates that learners can be divided into 11 groups of time spent on overall topics.

B) Progress on learners' learning performance can be divided into three groups:

- i) Improvements in Learning Performance
- ii) No Change in Learning Performance
- iii) Decline in Learning Performance

#### ***i) Improvements in Learning Performance***

- a. Learners with “R”, “K” and “VARK” based LP have shown great advancements on their learning performance by doing better on their assessments.
- b. Learners with accessibility of contents materials of type “RS”, “AKRS” and “AKRD” have shown a great deal on their learning performance by doing better on their assessments.

#### ***ii) No Change in Learning Performance***

- a. Learners with “AR” and “VRK” based LP have not shown much change on their learning performance.
- b. Learners with accessibility of contents materials of type “KRS” have not shown much change on their learning performance.

***iii) Decline in Learning Performance***

- a. Learners with “V”, “A”, “VK” and “RK” based LP have shown a declination on their learning performance.
- b. Learners with accessibility of contents materials of type “RD” and “ARD” type of contents materials have shown a declination on their learning performance.

**6.3.2 Data Analysis and Finding on learners’ performance based on A<sub>L</sub>ELS and PELS**

Sections above included discussions on the performance of learners’ outcome based on two different types of content-provider systems: (i) VARK- and (ii) ARK-based mechanism. On the other hand, to learn more about learners overall performance and method of measuring them, the chi-square test were applied to those outcomes. The common procedure to use chi-square-based test is to introduce two hypotheses and then proving one of them is the correct hypothesis and the other one is not.

Hypotheses are as follows:

H<sub>0</sub>: There is no relationship between both A<sub>L</sub>ELS and PELS based on the number of passed or failed learners on varieties of different types of assessment contents.

H<sub>1</sub>: The opposite of H<sub>0</sub> hypothesis.

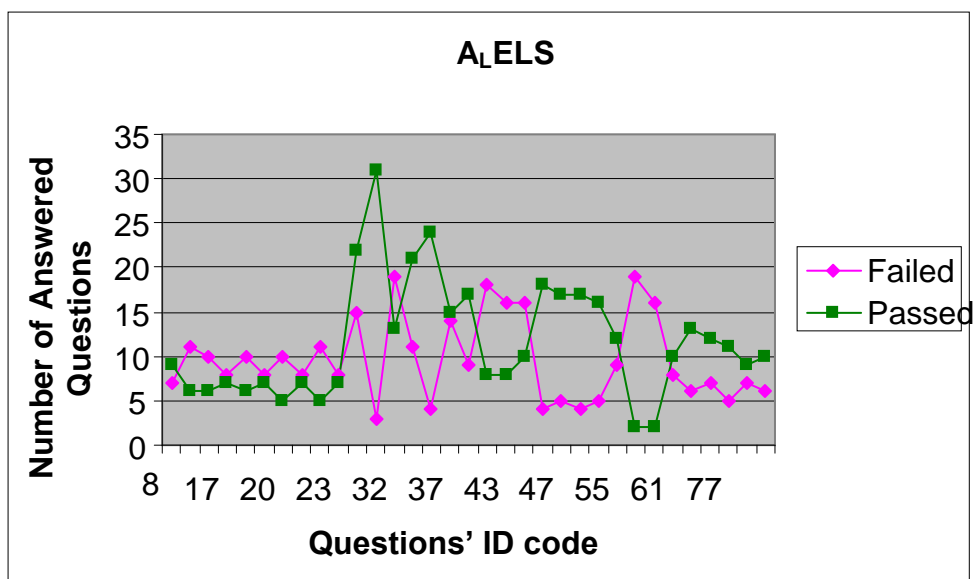
**6.3.2.1 Results of learners’ performance based on A<sub>L</sub>ELS and PELS**

Comparing both types of assessment contents for all types of assessment questions have given following outcomes (Table 16) and their analysis have been presented on both charts (Figure 34 and Figure 35):



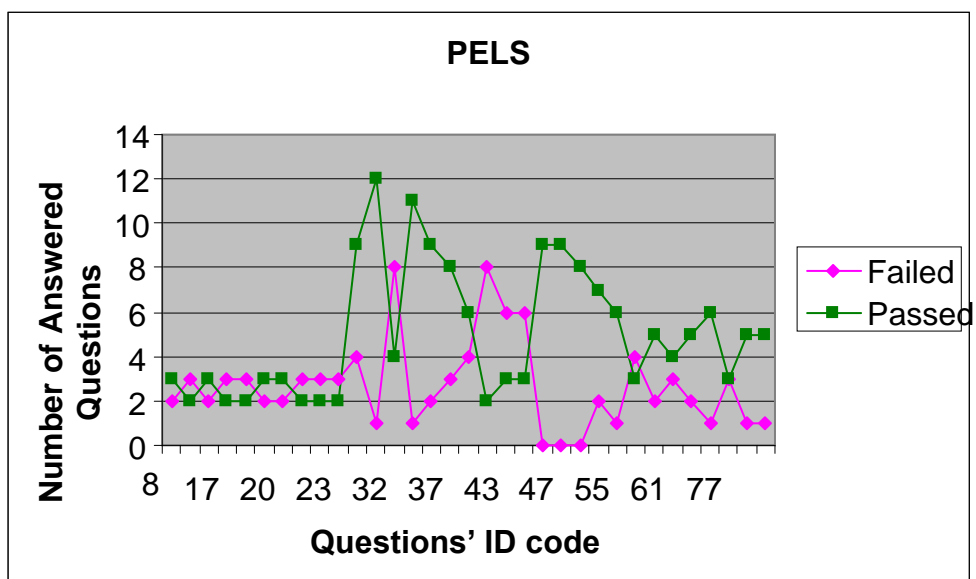
| A <sub>1</sub> ELS |                       |        |        | PELS |                       |        |        |
|--------------------|-----------------------|--------|--------|------|-----------------------|--------|--------|
| Q_id               | Total No. Of Learners | Failed | Passed | Q_id | Total No. Of Learners | Failed | Passed |
| 8                  | 16                    | 7      | 9      | 8    | 5                     | 2      | 3      |
| 15                 | 17                    | 11     | 6      | 15   | 5                     | 3      | 2      |
| 16                 | 16                    | 10     | 6      | 16   | 5                     | 2      | 3      |
| 17                 | 15                    | 8      | 7      | 17   | 5                     | 3      | 2      |
| 18                 | 16                    | 10     | 6      | 18   | 5                     | 3      | 2      |
| 19                 | 15                    | 8      | 7      | 19   | 5                     | 2      | 3      |
| 20                 | 15                    | 10     | 5      | 20   | 5                     | 2      | 3      |
| 21                 | 15                    | 8      | 7      | 21   | 5                     | 3      | 2      |
| 22                 | 16                    | 11     | 5      | 22   | 5                     | 3      | 2      |
| 23                 | 15                    | 8      | 7      | 23   | 5                     | 3      | 2      |
| 27                 | 37                    | 15     | 22     | 27   | 13                    | 4      | 9      |
| 29                 | 34                    | 3      | 31     | 29   | 13                    | 1      | 12     |
| 32                 | 32                    | 19     | 13     | 32   | 12                    | 8      | 4      |
| 33                 | 32                    | 11     | 21     | 33   | 12                    | 1      | 11     |
| 36                 | 28                    | 4      | 24     | 36   | 11                    | 2      | 9      |
| 37                 | 29                    | 14     | 15     | 37   | 11                    | 3      | 8      |
| 40                 | 26                    | 9      | 17     | 40   | 10                    | 4      | 6      |
| 41                 | 26                    | 18     | 8      | 41   | 10                    | 8      | 2      |
| 43                 | 24                    | 16     | 8      | 43   | 9                     | 6      | 3      |
| 45                 | 26                    | 16     | 10     | 45   | 9                     | 6      | 3      |
| 46                 | 22                    | 4      | 18     | 46   | 9                     | 0      | 9      |
| 47                 | 22                    | 5      | 17     | 47   | 9                     | 0      | 9      |
| 50                 | 21                    | 4      | 17     | 50   | 8                     | 0      | 8      |
| 51                 | 21                    | 5      | 16     | 51   | 9                     | 2      | 7      |
| 55                 | 21                    | 9      | 12     | 55   | 7                     | 1      | 6      |
| 56                 | 21                    | 19     | 2      | 56   | 7                     | 4      | 3      |
| 60                 | 18                    | 16     | 2      | 60   | 7                     | 2      | 5      |
| 61                 | 18                    | 8      | 10     | 61   | 7                     | 3      | 4      |
| 64                 | 19                    | 6      | 13     | 64   | 7                     | 2      | 5      |
| 65                 | 19                    | 7      | 12     | 65   | 7                     | 1      | 6      |
| 77                 | 16                    | 5      | 11     | 77   | 6                     | 3      | 3      |
| 78                 | 16                    | 7      | 9      | 78   | 6                     | 1      | 5      |
| 79                 | 16                    | 6      | 10     | 79   | 6                     | 1      | 5      |

Table 16: List of questions and learner's outcome of assessments



**Figure 34:** Chart of the list of questions (based on their ID number in the system) and their performance in an A<sub>L</sub>ELS

Further explanation on the relationship between the number of questions answered and learners' learning performance in an adaptable e-learning system which does not provide any clear pattern is given in the following section 6.3.2.2.



**Figure 35:** Chart of the list of questions (based on their ID number in the system) and their performance in an P\_ELS

Further explanation on the relationship between the number of questions answered and learners' learning performance in a personalised e-learning system which does not provide any clear pattern is given in the following section 6.3.2.2.

### 6.3.2.2 Discussion of findings

The diagrams above (Figure 34 and Figure 35) do not show any clear relationship between the outcome of both types of e-learning systems and the number of passed or failed learners in assessment contents. However, by taking a closer look, there are few differences and similarities between both diagrams. To obtain a better understanding and possibly a new outcome of both diagrams, results of assessments could be categorised into three different types of Recall, Competency and Understanding types of assessment content materials (detailed list of questions are included in the production log: the section on "Questions").

Following table (Table 17) is the list of assessment-based (not practice-based) questions and their types related (Recalling, Understanding and Competency types of questions) to individual content object, learning object, subject and topic.

| topic_id | sub_id | LO_id | co_id | acpcq_id | acpcq_RUC |
|----------|--------|-------|-------|----------|-----------|
| 2        | 43     | 19    | 35    | 27       | U         |
| 2        | 43     | 20    | 38    | 29       | U         |
| 2        | 43     | 21    | 41    | 32       | R         |
| 2        | 43     | 21    | 41    | 33       | R         |
| 3        | 45     | 25    | 53    | 36       | R         |
| 3        | 45     | 25    | 53    | 37       | U         |
| 3        | 45     | 26    | 56    | 40       | U         |
| 3        | 45     | 26    | 56    | 41       | U         |
| 3        | 45     | 27    | 59    | 43       | U         |
| 4        | 46     | 28    | 62    | 45       | R         |
| 5        | 49     | 17    | 74    | 50       | R         |
| 5        | 49     | 17    | 74    | 51       | R         |
| 5        | 49     | 31    | 71    | 46       | U         |
| 5        | 49     | 31    | 71    | 47       | U         |
| 5        | 50     | 32    | 77    | 55       | C         |
| 5        | 50     | 32    | 77    | 56       | C         |
| 5        | 50     | 33    | 80    | 60       | C         |
| 5        | 50     | 33    | 80    | 61       | C         |
| 5        | 50     | 34    | 83    | 64       | C         |
| 5        | 50     | 34    | 83    | 65       | C         |
| 6        | 41     | 14    | 86    | 8        | C         |
| 6        | 41     | 14    | 86    | 15       | C         |
| 6        | 41     | 14    | 86    | 16       | C         |
| 6        | 41     | 14    | 86    | 17       | C         |
| 6        | 41     | 14    | 86    | 18       | C         |
| 6        | 41     | 14    | 86    | 19       | C         |
| 6        | 41     | 14    | 86    | 20       | C         |
| 6        | 41     | 14    | 86    | 21       | C         |
| 6        | 41     | 14    | 86    | 22       | C         |
| 6        | 41     | 14    | 86    | 23       | C         |
| 6        | 41     | 15    | 89    | 77       | U         |
| 6        | 41     | 15    | 89    | 78       | U         |
| 6        | 41     | 15    | 89    | 79       | R         |

Keys:

topic\_id: Topic identification key number

sub\_id: Subject identification key number

LO\_id: Learning object identification key number

co\_id: content object identification key number

acpcq\_id: Assessment content and practice content related questions identification key number

acpcq\_RCU: Assessment content and practice content related questions of type recall, competency and understating identification key number

**Table 17: List of assessment questions and their related Topics, Subjects, Learning Objects, Content Objects and their types based on (Recalling, Understanding and Competency)**

Table 17 presents a list of different types of assessment contents as a collection of seven (7) recalling (R), ten (10) understanding (U) and sixteen (16) competency (C) types of questions as part of assessment.

The following is an analysis of data gathered on learners' responses to different types of recall, competency and understanding-based types of assessment content materials (questions):

**(i) Outcome of recall-based type of assessment contents:** Data gathered in the database on learners' activities was categorised and analysed as follow (Table 18):

| R          |     |      |
|------------|-----|------|
|            | ELS | PELS |
| Passed (1) | 111 | 47   |
| Failed (0) | 65  | 20   |

**Table 18: Outcome of Recall-based type of assessment**

Note: On the above table, numbers are based on total number of questions answered by all relevant learners. For example, 47 is the total number of questions answered correctly by all students which the type of exam questions was in recalling (R) type.

By using chi-squared test on data gathered through the activities of learners on answering Recall-based type of assessment contents (ACs), with the degree of freedom of one ( $df = 1$ ) and significance level of  $\alpha = 0.05$ , the calculated chi-squared value of 1.07 is much lower than the critical value of 3.184. ***This means the default hypothesis for finding any relationship between the degree of passed and failed in two different types of ELS are rejected.***

**(ii) Outcome of Competency-based type of assessment contents:** Data gathered in the database on learners' activities was categorised and analysed as follow (Table 19).

| <b>C</b>          |            |             |
|-------------------|------------|-------------|
|                   | <b>ELS</b> | <b>PELS</b> |
| <b>Passed (1)</b> | 116        | 53          |
| <b>Failed (0)</b> | 156        | 39          |
| <b>Total</b>      | 272        | 92          |

**Table 19: Outcome of Competency-based type of assessment**

The value of 6.19 as the outcome of chi-squared test on Competency-based type of contents materials shows a reliable relationship between  $A_1$ ELS and PEELS based on the number of learners' outcome of passed or failed on assessment contents.

Basically because  $6.19 > \text{critical test } (5.0239) \Rightarrow$  the hypothesis of (section 6.3.2)

*“There is no relationship between both the degree of passed and failed in ELS and PEELS” is rejected which means there is a relationship between Competency type of questions and learners' successfully completion of their course.*

**(iii) Outcome of Understanding-based type of assessment contents:** Data gathered in the database on learners' activities was categorised and analysed as follow (Table 20).

| <b>U</b>          |            |             |
|-------------------|------------|-------------|
|                   | <b>ELS</b> | <b>PELS</b> |
| <b>Passed (1)</b> | 156        | 66          |
| <b>Failed (0)</b> | 96         | 30          |
| <b>Total</b>      | 252        | 96          |

**Table 20: Outcome of Understanding-based type of assessment**

The value of 1.41 (which is less than the critical value of 3.184) as the outcome of chi-squared test on Understanding-based type of contents materials accepts the reliability of the first hypothesis which is the rejection of the relationship between

A<sub>L</sub>ELS and PELS based on the number of learners' outcome of passed or failed on Understanding-based type of assessment contents.

**Conclusion:** As presented above, there is a clear proof of the relationship between both A<sub>L</sub>ELS and PELS (Table 21, Figure 36 and Figure 37).

| A <sub>L</sub> ELS |        |        | PELS  |        |        |
|--------------------|--------|--------|-------|--------|--------|
| Q-No.              | Failed | Passed | Q-No. | Failed | Passed |
| 11                 | 9      | 12     | 11    | 1      | 6      |
| 12                 | 19     | 2      | 12    | 4      | 3      |
| 13                 | 16     | 2      | 13    | 2      | 5      |
| 14                 | 8      | 10     | 14    | 3      | 4      |
| 15                 | 6      | 13     | 15    | 2      | 5      |
| 16                 | 7      | 12     | 16    | 1      | 6      |

Table 21: Outcome of Competency-based assessments based on different types of ELs.

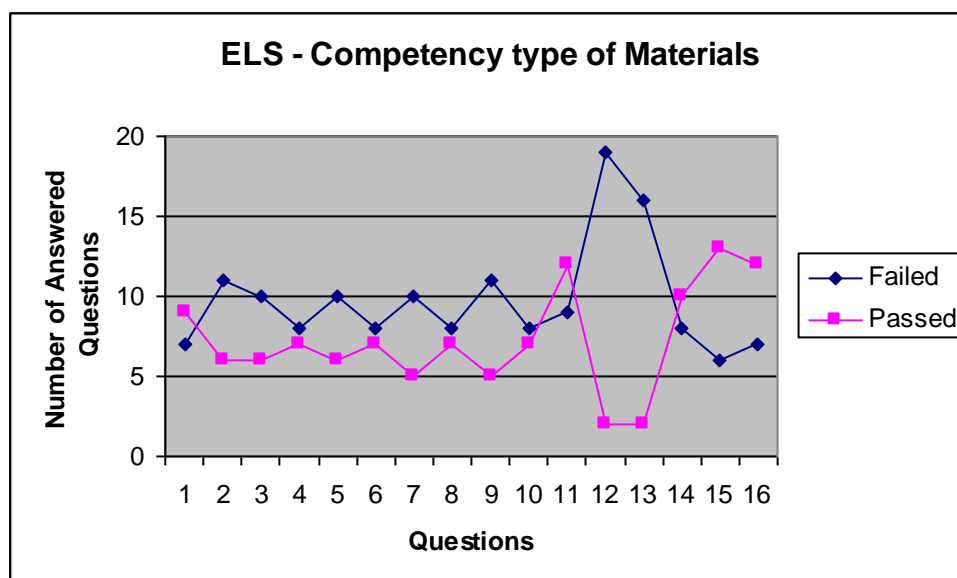


Figure 36: Chart of contents from Table 21 for A<sub>L</sub>ELS.

The explanation is given after the following chart.

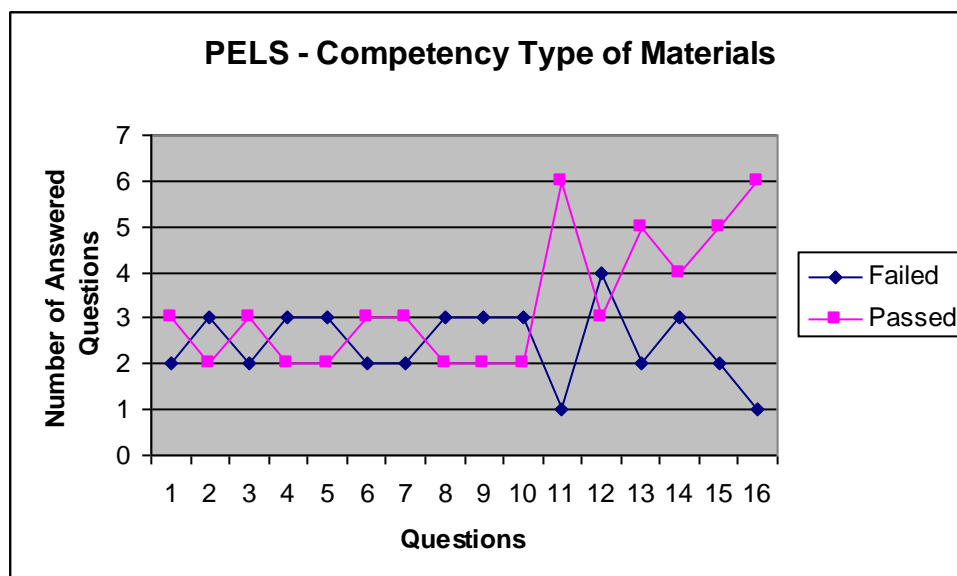


Figure 37 Chart of contents from Table 21 for PEELS.

Although, the similarity of charts (Figure 36 and Figure 37) on their first parts shows the possibility of their relativeness to the contents of questions, the end part of graph (Figure 37) is clearly an indication of the growth of number of learners who have passed competency-based types of assessments.

### 6.3.3 Conclusion on this section

As mentioned in sections 6.3.1 and 6.3.2, the outcome of these two major sections supports differences of effects that both types of e-learning systems ( $A_{L}EL S$  and PEELS) have on the performance of learners. However, further data analysis from a different perspective is needed to support these effects, therefore a thorough investigation and evaluation of learners-gained-knowledge on the basis of different categories of questions of type, namely recall (R), understanding (U) and competency (C), is required. Furthermore, this section (6.3) demonstrated there is a difference between the uses of two types of ELSs but it is not conclusive, since there is not enough clarity at moment, therefore there is a need to reanalyse the data from a different perspective to consider the



different types of question types and to determine a greater level of differentiation or clarity.

#### **6.4 Data Analysis and Finding – categorisation of learners outcome based on the type of assessment questions and types of ELSs**

Hypothesis developed in section 2.8 which is about finding any correlation between learners' learning performance while interacting with two types of e-learning systems – adaptable and personalised ELS.

The tracking unit of the system (Chapter 5) has stored large amounts of data which will be used to learn about any possible relationship between learners' interaction with content material based on types of e-learning systems and their learning preferences. The observations and analysis of data are based on the outcome of assessments; moreover, to differentiate this outcome, two other methodologies are presented: (i) Grouping learners based on their total number of answered questions, and (ii) grouping learners based on the number of 33 possible attempted answered questions in different e-learning systems. These two methods will be used to learn about any effects that one has on the other. One element would be studying a learner's participation in assessing his/her knowledge on a topic, and the other is the study of a learner's performance while interacting with course materials in different e-learning environments (systems).

### **6.4.1 Analysis of learners' performance based on assessment outcomes without the consideration of their assigned type of ELS (A<sub>L</sub>ELS and PELS)**

The e-learning systems developed to test the hypothesis have a tracking mechanism (section 5.3, Figure 27) which keeps track of learners' activities throughout their activities in the system. To find out how a learner has performed and to investigate his/her learning performance, all assessment responses have been stored and only those which have been the last result were accepted as the learner's answer to assessment questions. This is done to prevent the repeated records gathered by learners who have made several attempts to answer the same question and changed their responses, which would interfere with the data analysis. The gathered data are presented in Table 22.

The following table (Table 22) shows the performance of all 74 learners. These learners have had different attempts on different practice and assessment questions; however, the table only presents their attempts on assessment questions. Out of a total of 1203 attempts on 33 assessment questions, 739 (61.43%) correct answers were made which is a much higher value (1.59 times) than 464 (38.57%) incorrect answers on the same number of assessment questions. The table includes a list of learners and their detailed assessment outcome based on individual assessment questions. The outcome is presented in the form of whether the attempt on the answer was correct (T = True) or incorrect (F = False). The table also includes a total number of correct and incorrect answers for each learner (arranged horizontally) and the total number of answers for each question (arranged vertically).

| No. | Learner ID Number | Question ID Number |    |    |    |    |    |    |    |    |    |    |    |    |    |    |    |    |    |    |    |    |    |    |    |    |    |    |    | Total-TRUE | Total-FALSE | Total |    |    |    |    |    |    |    |    |
|-----|-------------------|--------------------|----|----|----|----|----|----|----|----|----|----|----|----|----|----|----|----|----|----|----|----|----|----|----|----|----|----|----|------------|-------------|-------|----|----|----|----|----|----|----|----|
|     |                   | 8                  | 15 | 16 | 17 | 18 | 19 | 20 | 21 | 22 | 23 | 27 | 29 | 32 | 33 | 36 | 37 | 40 | 41 | 43 | 45 | 46 | 47 | 50 | 51 | 55 | 56 | 60 | 61 |            |             |       | 64 | 65 | 77 | 78 | 79 |    |    |    |
| 1   | 76                |                    |    |    |    |    |    |    |    |    |    | F  | T  | F  | F  | T  | F  |    |    |    |    |    |    |    |    |    |    |    |    |            |             |       |    |    | 2  | 4  | 6  |    |    |    |
| 2   | 81                |                    |    |    |    |    |    |    |    |    |    | T  | T  | F  | F  | T  | T  |    |    |    |    |    |    |    |    |    |    |    |    |            |             |       |    |    | 4  | 2  | 6  |    |    |    |
| 3   | 83                |                    |    |    |    |    |    |    |    |    |    | F  | T  | F  | T  |    |    |    |    |    |    |    |    |    |    |    |    |    |    |            |             |       |    |    | 2  | 2  | 4  |    |    |    |
| 4   | 86                |                    |    |    |    |    |    |    |    |    |    | T  | T  | T  | F  | T  | F  |    |    |    |    |    |    |    |    |    |    |    |    |            |             |       |    |    | 4  | 2  | 6  |    |    |    |
| 5   | 87                | F                  | F  | F  | F  | F  | T  | F  | F  | F  | F  | T  | F  | F  | T  | T  | T  | T  | F  | F  | F  | T  | T  | T  | T  | T  | T  | F  | F  | T          | T           | F     | F  | F  | 14 | 19 | 33 |    |    |    |
| 6   | 89                |                    |    |    |    |    |    |    |    |    |    | F  | T  | T  | F  | T  | F  | F  | F  | F  | F  | F  | T  | T  | T  | T  | F  | F  | F  | T          | T           |       |    |    | 9  | 11 | 20 |    |    |    |
| 7   | 91                |                    |    |    |    |    |    |    |    |    |    | T  | T  | T  | F  | T  | F  | T  | F  |    |    |    |    |    |    |    |    |    |    |            |             |       |    |    |    | 5  | 3  | 8  |    |    |
| 8   | 97                | T                  | F  | T  | F  | F  | F  | F  | F  | F  | F  |    |    |    |    |    |    |    |    |    |    |    |    |    |    |    |    |    |    |            |             |       |    | T  | F  | T  | 4  | 9  | 13 |    |
| 9   | 100               | T                  | T  | T  | T  | T  | T  | T  | T  | T  | T  | T  | T  | T  | T  | T  | F  | T  | F  | F  | T  | T  | T  | T  | T  | F  | F  | T  | T  | T          | T           | T     | T  | T  | 28 | 5  | 33 |    |    |    |
| 10  | 101               |                    |    |    |    |    |    |    |    |    |    | F  | T  | F  | T  | T  | F  | T  | T  | T  | F  | T  | T  | T  | T  | F  | F  |    |    |            |             |       |    |    |    | 10 | 6  | 16 |    |    |
| 11  | 106               |                    |    |    |    |    |    |    |    |    |    | T  | T  |    |    |    |    |    |    |    |    |    |    |    |    |    |    |    |    |            |             |       |    |    |    |    | 2  | 0  | 2  |    |
| 12  | 115               |                    |    |    |    |    |    |    |    |    |    | F  | F  | F  | T  | T  | T  | F  | F  | F  | T  | T  | T  | T  | F  | F  |    |    |    |            |             |       |    |    |    |    | 8  | 8  | 16 |    |
| 13  | 117               |                    |    |    |    |    |    |    |    |    |    | T  | T  | T  | T  | T  | T  | F  | F  | F  | F  | T  | T  | T  | T  | T  | F  | F  | T  | T          | T           | T     | T  | T  | T  | 17 | 6  | 23 |    |    |
| 14  | 124               |                    |    |    |    |    |    |    |    |    |    | T  | T  | F  | T  | T  | T  | T  | F  |    |    |    |    |    |    |    |    |    |    |            |             |       |    |    |    |    |    | 6  | 2  | 8  |
| 15  | 125               | F                  | T  | F  | F  | F  | F  | F  | T  | F  | F  | T  | T  | T  | T  | T  | T  | T  | T  | T  | F  | T  | T  | T  | T  | T  | F  | F  | T  | T          | T           | T     | T  | T  | 22 | 11 | 33 |    |    |    |
| 16  | 129               |                    |    |    |    |    |    |    |    |    |    |    | T  |    |    |    |    |    |    |    |    |    |    |    |    |    |    |    |    |            |             |       |    |    |    |    |    | 1  | 0  | 1  |
| 17  | 132               |                    |    |    |    |    |    |    |    |    |    | F  | T  | F  | T  | T  | T  | T  | F  | F  | F  | T  | T  |    | F  |    |    |    |    |            |             |       |    |    |    |    |    | 7  | 6  | 13 |
| 18  | 134               | T                  | T  | T  | T  | T  | T  | T  | F  | T  | F  | T  | T  | F  | F  | T  | F  | T  | F  | F  | T  | T  | T  | T  | T  | T  | F  | F  | F  | T          | T           | T     | T  | T  | T  | 23 | 10 | 33 |    |    |
| 19  | 142               |                    |    |    |    |    |    |    |    |    |    | T  | T  | T  | F  | T  | F  | T  | T  | T  | F  | T  | T  | T  | T  | F  | T  | F  | T  | T          | T           | T     | T  | T  | T  | F  | 17 | 6  | 23 |    |
| 20  | 145               | T                  | T  | T  | T  | T  | T  | F  | F  | F  | T  | F  | T  | T  | T  | T  | T  | T  | F  | T  | F  | T  | T  | T  | T  | F  | T  | T  | T  | T          | T           | T     | T  | T  | T  | 26 | 7  | 33 |    |    |
| 21  | 149               | F                  | F  | F  | F  | T  | T  | T  | F  | F  | T  | F  | F  | F  | F  | T  | T  | F  | T  | T  | T  | F  | T  | T  | T  | F  | T  | T  | T  | F          | T           | T     | F  | T  | F  | T  | 17 | 16 | 33 |    |
| 22  | 152               | T                  | T  | T  | F  | F  | T  | F  | F  | T  | T  | T  | T  | F  | T  | T  | F  | F  | F  | F  | T  | F  | F  | T  | T  | F  | F  | F  | T  | F          | F           | F     | F  | F  | F  | 14 | 19 | 33 |    |    |
| 23  | 153               |                    |    |    |    |    |    |    |    |    |    | T  | T  | F  | T  | F  | F  | F  | F  |    |    |    |    |    |    |    |    |    |    |            |             |       |    |    |    |    |    | 3  | 5  | 8  |
| 24  | 154               |                    |    |    |    |    |    |    |    |    |    | F  |    |    |    |    |    |    |    |    |    |    |    |    |    |    |    |    |    |            |             |       |    |    |    |    |    | 0  | 1  | 1  |

|    |     |   |   |   |   |   |   |   |   |   |   |   |   |   |   |   |   |   |   |   |   |   |   |   |   |   |   |   |   |   |   |   |   |    |    |    |    |    |    |
|----|-----|---|---|---|---|---|---|---|---|---|---|---|---|---|---|---|---|---|---|---|---|---|---|---|---|---|---|---|---|---|---|---|---|----|----|----|----|----|----|
| 25 | 169 | F | F | F | F | F | F | F | T | F | F | F | T | F | T | T | T | T | F | F | F | T | T | F | T | F | F | F | F | F | F | F | F | T  | 10 | 23 | 33 |    |    |
| 26 | 184 |   |   |   |   |   |   |   |   |   | F | T | T | T | F | T | F | F | F | F | T | T | T | T | F | F |   |   | F | T |   |   |   | 9  | 9  | 18 |    |    |    |
| 27 | 188 | T | T | T | T | T | T | T | T | T | T | T | F | T | F | F | T | F | T | T | F | F | F | T | F | F | T | T | T | T | T | T | T | 24 | 9  | 33 |    |    |    |
| 28 | 196 | F | F | F | F | F | T | T | F | F | F | T | T | F | F |   |   |   |   |   |   |   |   |   |   |   |   |   |   |   |   |   |   |    | 5  | 10 | 15 |    |    |
| 29 | 218 |   |   |   |   |   |   |   |   |   |   |   | T | T |   |   |   |   |   |   |   |   |   |   |   |   |   |   |   |   |   |   |   |    | 2  | 0  | 2  |    |    |
| 30 | 221 | T | F | F | F | F | F | F | F | F | T | F | T | F | F | T | T | T | F | F | F | T | T | T | F | T | F | F | T | T | T | T | F | F  | 14 | 19 | 33 |    |    |
| 31 | 226 |   |   |   |   |   |   |   |   |   |   | F |   |   |   |   |   |   |   |   |   |   |   |   |   |   |   |   |   |   |   |   |   |    | 0  | 1  | 1  |    |    |
| 32 | 236 | T | F | F | T | T | F | F | T | F | F | T | T | F | T | F | F | T | T | F | F | T | F | F | T | F | F | T | T | F | F | F | F | F  | 14 | 19 | 33 |    |    |
| 33 | 254 | F | F | F | F | F | F | F | F | F | T | T | T | F | T | T | T | F | F | F | T | F | F | F | F | F | F | F | F | T | F | T | T | 10 | 23 | 33 |    |    |    |
| 34 | 268 |   |   |   |   |   |   |   |   |   |   |   | T | T | F | T | T | T | T | F | T | F | T | T |   |   |   |   |   |   |   |   |   |    | 9  | 3  | 12 |    |    |
| 35 | 269 | F | F | F | F | F | F | F | F | F | F | T | T | T | T | T | T | T | T | F | F | T | T | T | T | F | T | T | F | F |   |   |   |    | 15 | 15 | 30 |    |    |
| 36 | 276 | T | F | F | T | F | F | F | T | F | F | T | T | T | T | T | T | T | F | F | T | T | T | T | T | F | F | T | T | T | T | T | T | 22 | 11 | 33 |    |    |    |
| 37 | 282 |   |   |   |   |   |   |   |   |   |   |   | T | T | T | F | T | T | T | T | F | T | T | T | T | F | F | F | T | T |   |   |   |    | 15 | 5  | 20 |    |    |
| 38 | 291 |   |   |   |   |   |   |   |   |   |   |   | F | T | F | T |   |   |   |   |   |   |   |   |   |   |   |   |   |   |   |   |   |    |    | 2  | 2  | 4  |    |
| 39 | 302 | T | F | T | F | F | F | T | F | F | F | T | T | F | T | T | F | F | F | F | T | T | T | T | T | F | F | T | F | F | T | F | T | T  | 16 | 17 | 33 |    |    |
| 40 | 305 |   |   |   |   |   |   |   |   |   |   |   | F | T | T | T | T | T | F | F | F | T |   |   |   |   |   |   |   |   |   |   |   |    |    | 6  | 4  | 10 |    |
| 41 | 313 |   |   |   |   |   |   |   |   |   |   |   | T | T | T | T | T | F | F | F | T | F | T | T | T | T | F | F | F | T | F |   |   |    | 11 | 9  | 20 |    |    |
| 42 | 326 |   |   |   |   |   |   |   |   |   |   |   | F | T | F | T | F | F | F | F | F | F | T | T | T | T |   |   |   |   |   |   |   |    |    | 6  | 8  | 14 |    |
| 43 | 327 | F | F | F | T | F | F | F | T | F | F | F | T | F | T | T | T | T | F | F | F | T | T | T | F | F | F | F | F | F | F | F | F | F  | 10 | 23 | 33 |    |    |
| 44 | 329 |   |   |   |   |   |   |   |   |   |   |   | T |   |   |   |   |   |   |   |   |   |   |   |   |   |   |   |   |   |   |   |   |    |    |    | 1  | 0  | 1  |
| 45 | 332 |   |   |   |   |   |   |   |   |   |   |   | T |   |   |   |   |   |   |   |   |   |   |   |   |   |   |   |   |   |   |   |   |    |    |    | 1  | 0  | 1  |
| 46 | 334 | T | T | T | T | T | T | T | T | T | T | T | T | T | T | T | T | T | T | T | T | T | T | T | T | T | T | T | T | T | T | T | T | T  | 33 | 0  | 33 |    |    |
| 47 | 342 |   |   |   |   |   |   |   |   |   |   |   | F | T | T | T | T | T | T | F | T | T | T | T | T | F | T | T | T | T | F | T | T |    |    | 19 | 4  | 23 |    |
| 48 | 343 |   |   |   |   |   |   |   |   |   |   |   | T | T | F | F |   |   |   |   |   |   |   |   |   |   |   |   |   |   |   |   |   |    |    |    | 2  | 2  | 4  |
| 49 | 352 | T | T | T | T | T | T | T | T | T | T | T | T | F | T | T | T | T | F | T | F | T | T | T | F | T | F | T | T | T | T | T | T | T  | 28 | 5  | 33 |    |    |
| 50 | 357 |   |   |   |   |   |   |   |   |   |   |   |   | F | T | F | T | T | F | T | T | F | F |   |   |   |   |   |   |   |   |   |   |    |    |    | 5  | 5  | 10 |
| 51 | 389 | F | F | F |   |   |   |   |   |   |   |   |   | T | F | F | T | F | F | T | F | F | F | T | F | T | T | T | F | F | T | F | F | T  | T  | F  | 10 | 16 | 26 |
| 52 | 401 |   |   |   |   |   |   |   |   |   |   |   |   | T | T | T | T |   |   |   |   |   |   |   |   |   |   |   |   |   |   |   |   |    |    |    | 4  | 0  | 4  |
| 53 | 433 |   |   |   |   |   |   |   |   |   |   |   |   | T | F | F | T | T | T |   |   |   |   |   |   |   |   |   |   |   |   |   |   |    |    |    | 4  | 2  | 6  |
| 54 | 435 |   |   |   |   |   |   |   |   |   |   |   |   | T |   |   |   |   |   |   |   |   |   |   |   |   |   |   |   |   |   |   |   |    |    |    | 1  | 0  | 1  |
| 55 | 438 |   |   |   |   |   |   |   |   |   |   |   |   | F |   |   |   |   |   |   |   |   |   |   |   |   |   |   |   |   |   |   |   |    |    |    | 0  | 1  | 1  |



The source of our knowledge is information which must be deduced from data. Statistics is the language which can interpret this data into information and so into knowledge. Different tools and techniques are used for this purpose to give quantitative or qualitative explanations for any row of data. Bar graphs and Pareto charts are used for qualitative data (Ramachandran, K.M. & Tsokos, C.P. 2009). To use any graph there is a need for an organised row of data in a table, and when the amount of data increases, a frequency table is used which categorises groups of data into classes rather than presenting all data into a display. Different sets of frequency data are used which mostly depend on the use of the boundary of each class. The class boundary should be used for determining each group of data and it should not interfere with other sets of data. As such, the best classification would be halfway between the boundaries of two groups of numbers. For example there can be 9 or 10 answers but not 9.5 answers in this research. This method would certainly separate two adjacent groups of data. If  $f_i$  denotes the frequency of the class  $i$  and  $n$  is the sum of all frequencies, then the relative frequencies for the class  $i$  are defined as the ratio  $f_i/n$ . Therefore if there are different quantities of data in each class, to find the cumulative relative frequency for any class  $i$ , the equation would be  $\frac{1}{n} \sum_i f_i m_i$ , where  $n$  is the sum of all frequencies,  $f_i$  is the frequency of the data in each class  $i$ , and  $m_i$  is the mean average of data in each class (Ramachandran, K.M. & Tsokos, C.P. 2009). To do this analysis we should start determining the upper and lower limit of each class, which is shown below:

Upper limit of attempted questions: 33 questions have been attempted to answer (largest value).

Lower limit of attempted questions: 1 question has been attempted to answer (lowest value).

The lowest value would be one, which means the learner needs to answer at least one assessment question to be considered a participant in the experiment.

To find the number of classes the following formula would be used:

$$\text{Range} = \text{Largest value} - \text{Smallest value} = 33 - 1 = 32$$

$$\text{Class width} = (\text{Largest value} - \text{Smallest value}) / (\text{Number of classes})$$

To prevent a case of having only a few items of data in each class, the 4-class intervals will be used throughout this data analysis, as there are only 19 records of Personalised E-Learning System users (section 7.4.2.2) that exist. So the number of classes will be selected as 4.

$$\text{Class width} = \text{Range} / \text{Number of classes} = 32 / 4 = 8$$

But, if we decide to have 4 intervals of 8 values in each class, we will hit the value of 33 if we start the classification from 1. However, per regulation (Ramachandran, K.M. & Tsokos, C.P. 2009, p. 18), no data value should fall on the class boundary (as discussed above). Thus we will start the lower boundary from 0.5 and choose the 9 intervals as the classification of data to prevent both the possibility of meeting a value on a class boundary and of leaving one class with a value of 33, as shown in Table 23. The key here is to make the possible decisions between available options, such as the number of classes, width of each class and current number of data in each type of e-learning system (A<sub>L</sub>ELS and PELS):

| Division of number of learners into groups based on attempted answered questions |                 |
|--|-----------------|
| Group Label  | Class intervals |
| A  | 0.5 - 9.5       |
| B  | 9.5 - 18.5      |
| C  | 18.5 - 27.5     |
| D  | 27.5 - 36.5     |

*Table 23: Setting up groups of learners based on their attempts at answering questions*

At this stage the two hypotheses will be examined to see that if there are any data to support our hypothesis. It is common to think of the first hypothesis as “Life is boring and nothing is happening”, so by default the first hypothesis is null. The second hypothesis is to see if something exciting is happening and whether we do have sufficient data to back our claim (Diamond and Jefferies, 2006, p.139). The hypotheses then are as follows:

Categorisation Hypothesis<sub>0</sub> (CH<sub>0</sub>): There is no difference between groups in class intervals.

Categorisation Hypothesis<sub>1</sub> (CH<sub>1</sub>): There is a difference between groups in class intervals.

The aim here is to find that the data in all 4 groups is processed to prove or disprove one of the statements of CH<sub>0</sub> or CH<sub>1</sub> as shown in Table 24:

| Process of finding reasons for having more than one group for grouping learners based on their attempt to answer questions |             |           |        |                       |                               |  |
|--|-------------|-----------|--------|-----------------------|-------------------------------|--|
| Group Title  | Class       | Frequency | %      | m <sub>i</sub> (Mean) | m <sub>i</sub> f <sub>i</sub> | m <sub>i</sub> <sup>2</sup> f <sub>i</sub> |
| A  | 0.5 - 9.5   | 30        | 40.54  | 5                     | 150                           | 750  |
| B  | 9.5 - 18.5  | 14        | 18.92  | 14                    | 196                           | 2744                                       |
| C  | 18.5 - 27.5 | 8         | 10.81  | 23                    | 184                           | 4232                                       |
| D  | 27.5 - 36.5 | 22        | 29.73  | 32                    | 704                           | 22528                                      |
|  | Total       | n=74      | 100.00 | 74                    | 1234                          | 30254                                      |

*Table 24: Process of finding the mean of each class of attempted entries for grouping learners based on their attempts to answer the assessment questions.*



The sample mean is:

$$\tilde{x} = \frac{1}{n} \sum_i f_i m_i$$

where  $n$  is the sum of all frequencies,  $f_i$  is the frequency of the data in each class  $i$  and  $m_i$  is the mean average of data in each class

$$\tilde{x} = 1234 / 74 = 16.68$$

The sample variance is:

$$s^2 = \frac{\sum m_i^2 f_i - \frac{\left(\sum m_i f_i\right)^2}{n}}{n - 1}$$

$$s^2 = [30254 - (1234^2/74)] / (74 - 1) = 132.55$$

$$s = 11.51$$

### **Analysis of results to confirm one of the CHs**

Based on the calculations above, there is at least one group that exists with a mean average that is out of the range of  $16.68 \pm 11.51$  (i.e.  $16.68 + 11.51 = 27.19$  &  $16.68 - 11.51 = 5.17$ ), or in other words, the population means are not equal. Therefore, the first categorisation hypothesis ( $CH_0$ ) is wrong and we can agree that learners' classification can be divided into more than one group. Thus, based on the analysis of the data above, the histogram shown in Figure 38 is confirmed:

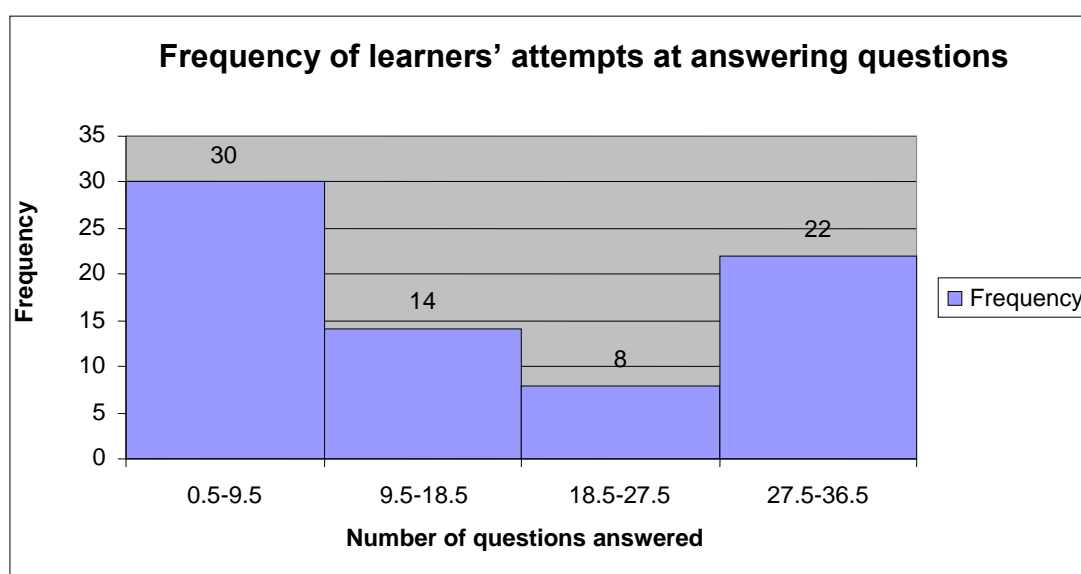


Figure 38: *Frequency of learners' attempts at answering questions in each class*

To further analyse learners' responses based on the table above (Table 22), a list of learners in each group is presented in Table 25. This type of grouping will be used to find any correlation between the learners in each group and their performance, in later sections.

| <b>List of learners in each group based on the number of questions answered</b> |   |  |
|---|---|--|
| <b>Group Title</b>  | <b>List of learners' ID in each group</b>   | <b>Total no. of learners in each group</b> |
| <b>A</b>  | 76, 81, 83, 86, 91, 106, 124, 129, 153, 154, 218, 226, 291, 329, 332, 343, 401, 433, 435, 438, 445, 447, 449, 464, 469, 485, 514, 531, 557, 568 | 30   |
| <b>B</b>  | 97, 101, 115, 132, 184, 196, 268, 305, 326, 357, 450, 495, 497, 569   | 14   |
| <b>C</b>  | 89, 117, 142, 282, 313, 342, 389, 517   | 8  |
| <b>D</b>  | 87, 100, 125, 134, 145, 149, 152, 169, 188, 221, 236, 254, 269, 276, 302, 327, 334, 352, 501, 507, 515, 530                                     | 22   |
| <b>Total</b>  |   | 74   |

**Table 25:** *List of learners in each group*

Now for all groups listed above, we should check for differences between the true and false responses. The outcome would be as follows (Table 26):

| <b>Number of learners in each group and number of their responses to assessments</b> |                        |                 |              |              |
|--|------------------------|-----------------|--------------|--------------|
| <b>Class Intervals</b>   |                        | <b>Answered</b> |              | <b>Total</b> |
| <b>Group</b>   | <b>No. of learners</b> | <b>True</b>     | <b>False</b> |              |
| <b>A</b>   | 0.5-9.5                | 78              | 32           | 110          |
| <b>B</b>   | 9.5-18.5               | 108             | 84           | 192          |
| <b>C</b>   | 18.5-27.5              | 116             | 62           | 178          |
| <b>D</b>   | 27.5-36.5              | 437             | 286          | 723          |
| <b>Total</b>   |                        | 739             | 464          | 1203         |

**Table 26:** *Number of learners in each group and number of their responses to assessments*

### **Searching for any correlation between responses in different groups (Table 26)**

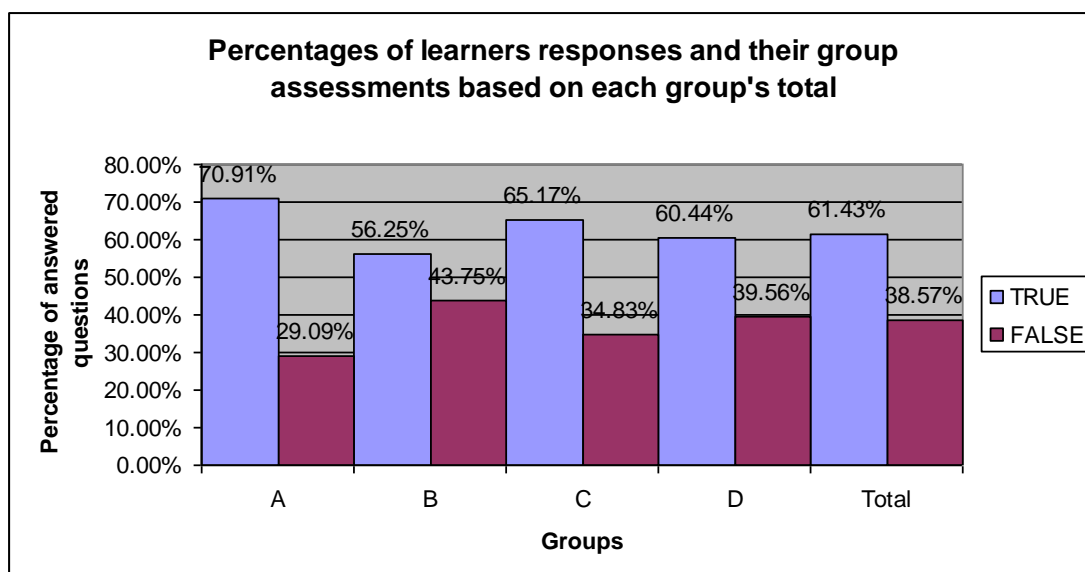
Further analysis on finding the correlation between responses in each group of learners is done below, on the basis of (i) comparing each class interval with the total

number of answered questions (whether true or false) in each class (the last column in Table 26 above), and (ii) the total number of either true (739) or false answers (464).

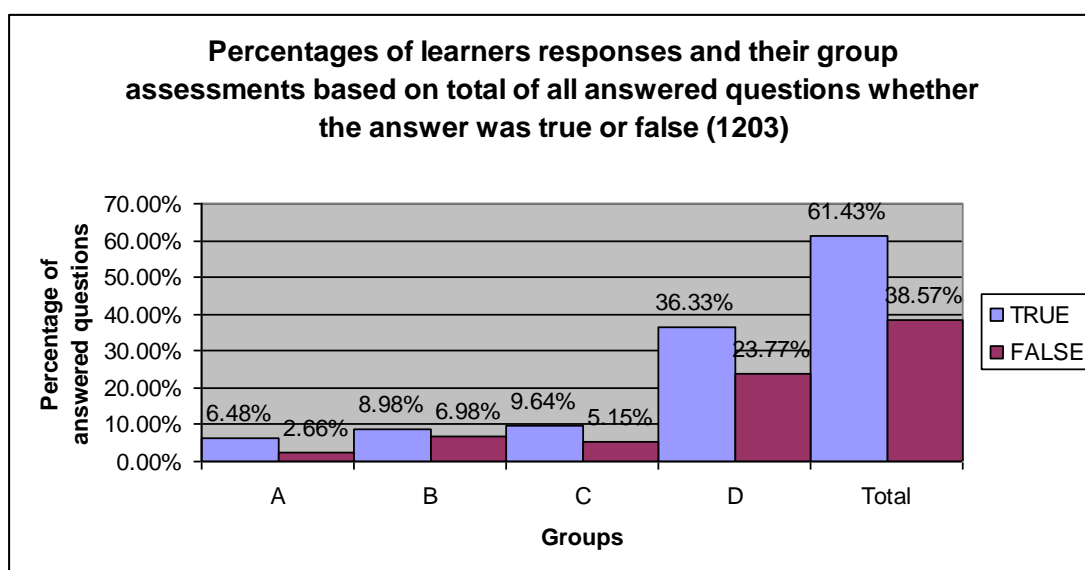
The outcome is presented in Table 27 and Figure 39 through to Figure 41:

| <b>Percentages of learners' responses and their group assessments based on different types of total</b>  |            |             |               |
|--|------------|-------------|---------------|
| <b>Based on each group's total</b>   |            |             |               |
| Group  | True       | False       | Group's total |
| A  | 70.91%     | 29.09%      | 110           |
| B  | 56.25%     | 43.75%      | 192           |
| C  | 65.17%     | 34.83%      | 178           |
| D  | 60.44%     | 39.56%      | 723           |
| Total  | 61.43%     | 38.57%      | 1203          |
| <p><i>Table 27.1: Percentages of learners' responses and their group assessments based on each group's total. For example: group A, number of true answers = 78; total number of answers for group A = 110, thus: <math>(78/110) * 100\% = 70.91\%</math>.</i></p> |            |             |               |
| <b>Based on the total of all answered questions whether the answer was true or false (1203)</b>  |            |             |               |
| Group  | True       | False       |               |
| A  | 6.48%      | 2.66%       |               |
| B  | 8.98%      | 6.98%       |               |
| C  | 9.64%      | 5.15%       |               |
| D  | 36.33%     | 23.77%      |               |
| Total  | 61.43%     | 38.57%      |               |
| <p><i>Table 27.2: Percentages of learners' responses and their group assessments based on total of all answered questions whether the answer was true or false. For example: <math>(78/1203) * 100\% = 6.48\%</math>.</i></p>                                      |            |             |               |
| <b>Based on the total of all answered questions either true or false</b>   |            |             |               |
| Group  | True (739) | False (464) |               |
| A  | 10.55%     | 6.90%       |               |
| B  | 14.61%     | 18.10%      |               |
| C  | 15.70%     | 13.36%      |               |
| D  | 59.13%     | 61.64%      |               |
| Total  | 100.00%    | 100.00%     |               |
| <p><i>Table 27.3: Percentages of learners' responses and their group assessments based on the total of all answered questions whether the answer was true or false. For example: <math>(78/739) * 100\% = 10.55\%</math>.</i></p>                                  |            |             |               |

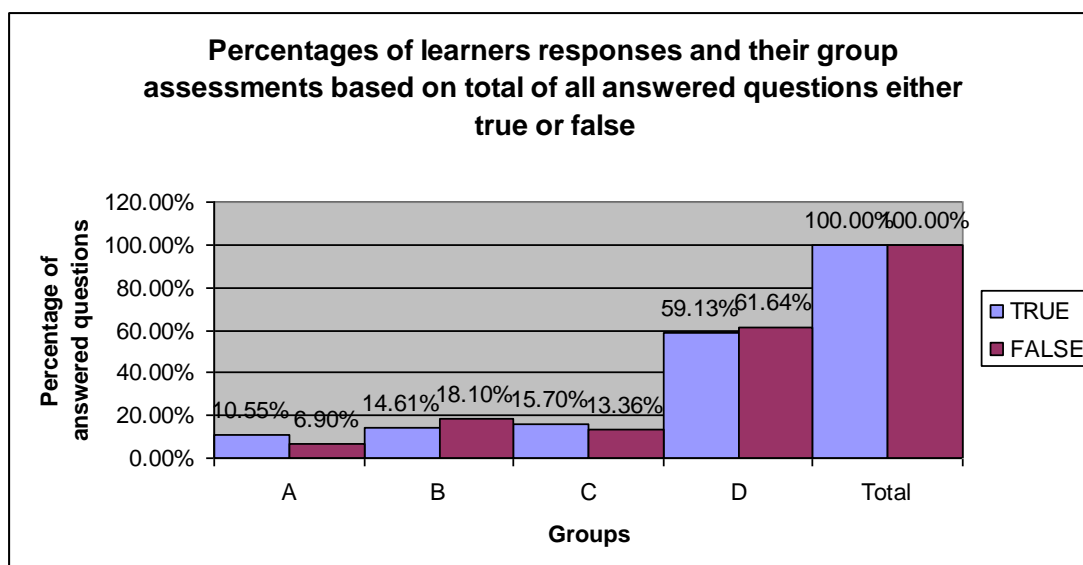
**Table 27: Percentages of learners' responses and their group assessments based on different types of total**



**Figure 39:** (Figure from Table 27.1): Percentages of learners' responses and their group assessments based on each group's total.



**Figure 40:** (Figure from Table 27.2): Percentages of learners' responses and their group assessments based on the total of all answered questions whether the answer was true or false



**Figure 41:** (Figure from Table 27.3): Percentages of learners' responses and their group assessments based on the total of all answered questions either the answer was true or false.

### **Preliminary Analysis - 1:**

Per hypothesis given in section 2.8, the increase in learning performance can be the outcome of the comparison between the number of correctly answered assessment questions with the number of incorrectly answered assessment questions. If the outcome was the same as and above one (100%) then the comparison has an indication of an increase on learning performance and can be interpreted as a sign of increase on the efficiency of learning and delivery of learning content materials. For example, the comparison of users of both A<sub>1</sub>ELS and PELS (Table 26) generated 739 correctly attempted answers to assessment questions in comparison with the 464 incorrectly answered questions, which is  $739 / 464 = 1.59$ , or in other words  $[(1.59 - 1) / 1.59] * 100\% = 37\%$  increase on the learners' learning performance.

Details of the same analysis are shown in Table 28 which provides a comparison of assessments for each group. Table 28 presents the higher percentage of correctly answered questions compared to incorrectly answered questions. For example,

learners in group A have answered questions 2.44 times (or 59.02%) and group D with 1.59 times (37.11%) more correctly responded to assessment questions.

| <b>Comparison of learners' learning performance</b> |                |              |                               |        |
|---|----------------|--------------|-------------------------------|--------|
| <b>Group (no. of attempted questions)</b>           | <b>Answers</b> |              | <b>Performance comparison</b> |        |
|   | <b>True</b>    | <b>False</b> |                               |        |
| <b>A (0.5-9.5)</b>                                  | 78             | 32           | 2.44                          | 59.02% |
| <b>B (9.5-18.5)</b>                                 | 108            | 84           | 1.29                          | 22.48% |
| <b>C (18.5-27.5)</b>                                | 116            | 62           | 1.87                          | 46.52% |
| <b>D (27.5-36.5)</b>                                | 437            | 286          | 1.53                          | 34.64% |
| <b>Total</b>  | 739            | 464          | 1.59                          | 37.11% |

**Table 28: Comparison of learners' learning performance**

As the comparison of learners' responses and their group assessments is based on the total of all answered questions whether the answers were true or false, it shows the same effect as the chart presented in Figure 39, which indicates the overall increase in learners' learning performance, and as such this is more proof supporting hypothesis one (sec 1.3) in terms of the effectiveness of adaptable and/or personalised e-learning systems on the delivery of knowledge.

However, the diagram in Figure 41 does not present a clear picture of learners' activities and their learning performance. For example, there is an increase in the level of learners' learning performance in groups A (True-10.55% to False-6.90%) and C (True-15.70% to False-13.36%) compared with a slight fall in the performance of groups B (True-14.61% to False-18.10%) and D (True-59.13% to False-61.64%). For further investigation on what has caused this effect, the elements of the type of e-learning system used by each individual learner should be investigated. Thus, learners will be divided into two groups of A<sub>L</sub>ELS and PELS and the effects of both environments on learners' learning performance will be investigated.

### **6.4.2 Investigation of learners' performance based on different types of ELS**

Learners' learning performance based on the different types of e-learning system (A<sub>L</sub>ELS and PELS) is investigated in the following sections. This investigation includes the observations and analysis of data based on adaptable and personalised e-learning systems with the consideration of a number of attempted assessment questions. In addition, as the system was an automatic type of categorisation of learners to different types of e-learning system, the number of learners assigned to each type of ELS is different from the others. The reason is that when learners clicked on the "Click here to Register" link on the index page of the web application (<https://cms1.gre.ac.uk/mscinduction/> - the production log - Appendix 25.12), they were automatically assigned to one of the two categories of learners. Although there were learners who had attempted to register to the course and couldn't continue and came back later to re-register, the order of assigning a learner to A<sub>L</sub>ELS and another to PELS had changed. This is the main reason why there were 55 learners assigned to A<sub>L</sub>ELS and 19 learners to the PELS type of e-learning system.

#### **6.4.2.1 Investigation of learners' performance based on A<sub>L</sub>ELS**

The rationale for the following analysis is to find any correlation between the number of learners with different attempts on assessment questions. Out of the 55 records of learners' registered as A<sub>L</sub>ELS users, with a total of 889 attempts at 33 assessment questions, 536 (60.29%) attempts with true answers were made, and 353 (39.71%) attempts with false answers on the same number of assessment questions. The level of correctly answered questions is  $(536/353 = 1.52)$  1.52 times higher than incorrectly answered assessments.

To compare the responses to assessments between different groups (A-D), who were assigned to an adaptable type of e-learning system, a histogram is used to visualise the frequency of the data. The same class interval that was used in section 6.4.1 and Table 23 is used again because the users of the A<sub>L</sub>ELS are from the same (as a subset of the original) group of e-learning systems, so they will be grouped into the same 4 class intervals as follows (Table 29):

| Number of A <sub>L</sub> ELS learners in each group |                 |                             |         |
|---|-----------------|-----------------------------|---------|
| Class Intervals                                     |                 | No. of learners (Frequency) | %       |
| Group Title   | No. of learners |                             |         |
| <b>A</b>  | 0.5-9.5         | 22                          | 40.00%  |
| <b>B</b>  | 9.5-18.5        | 11                          | 20.00%  |
| <b>C</b>  | 18.5-27.5       | 6                           | 10.91%  |
| <b>D</b>  | 27.5-36.5       | 16                          | 29.09%  |
| <b>Total</b>  |                 | 55                          | 100.00% |

Table 29: Number of A<sub>L</sub>ELS learners in each group

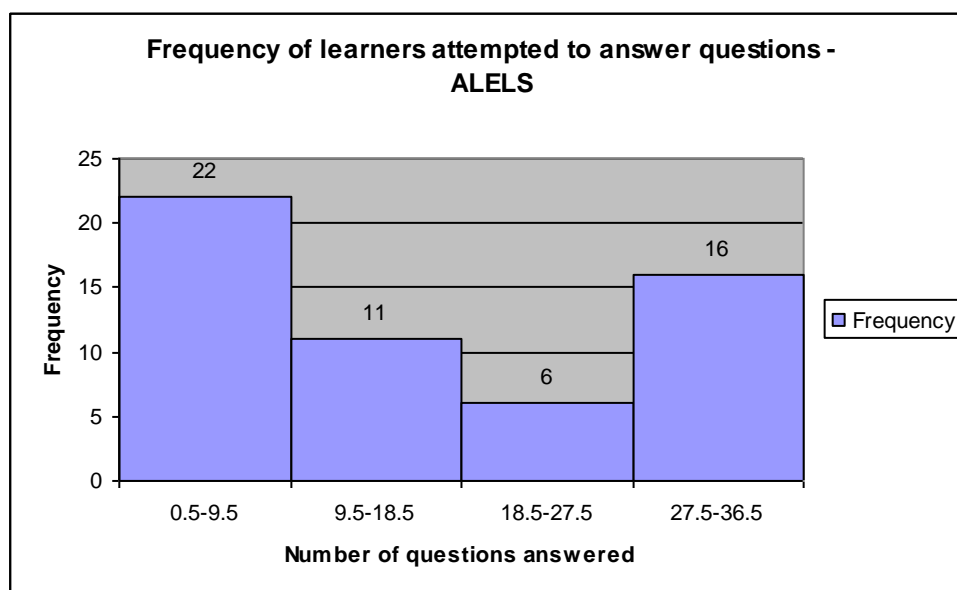


Figure 42: (Figure from Table 29): Frequency of A<sub>L</sub>ELS learners' attempts on answering questions

Based on Table 29, a list of relevant learners has been provided in Table 30 with their user identification number.



| <b>List of A<sub>L</sub>ELS learners in each group based on the number of questions answered (whether true or false)</b> |  |
|--|--|
| <b>Group Title</b>   | <b>List of learners' ID</b>  |
| A  | 76, 83, 86, 91, 106, 124, 129, 154, 218, 226, 329, 343, 401, 433, 435, 445, 447, 449, 469, 485, 531, 557 |
| B  | 97, 101, 115, 184, 196, 268, 305, 357, 495, 497, 569   |
| C  | 89, 142, 282, 313, 389, 517  |
| D  | 100, 125, 134, 145, 149, 152, 169, 188, 221, 236, 254, 276, 327, 501, 507, 515                           |

**Table 30:** *List of A<sub>L</sub>ELS learners in each group based on the number of questions answered (whether true or false)*

Now for all the above groups we should check for any difference between True and False responses. The comparison would be as follows (Table 31):

| <b>The number of A<sub>L</sub>ELS learners in each group and the number of their responses to assessments</b> |                        |                 |              |              |
|---|------------------------|-----------------|--------------|--------------|
| <b>Class Intervals</b>  |                        | <b>Answered</b> |              | <b>Total</b> |
| <b>Group Title</b>  | <b>No. of learners</b> | <b>True</b>     | <b>False</b> |              |
| <b>A</b>  | 0.5-9.5                | 59              | 21           | 80           |
| <b>B</b>  | 9.5-18.5               | 84              | 65           | 149          |
| <b>C</b>  | 18.5-27.5              | 80              | 52           | 132          |
| <b>D</b>  | 27.5-36.5              | 313             | 215          | 528          |
| <b>Total</b>  |                        | 536             | 353          | 889          |

**Table 31:** *The number of A<sub>L</sub>ELS learners in each group and the number of their responses to assessments*

Further analysis would show additional findings regarding the relevancy of the type of e-learning system (A<sub>L</sub>ELS and PELS) and learners' activities on taking assessments. These comparisons are done on the basis of (i) comparing each class interval with the total number of questions answered (whether true or false) in each class (the last column on the Table 31), and (ii) based on the total of either true (536) or false answers (353). The outcome is presented in Table 32:

**Percentages of ALELS learners' responses and their group assessments based on the different types of totals**

| Based on each group's total |        |        |               |
|-----------------------------|--------|--------|---------------|
| Group                       | True   | False  | Group's total |
| A                           | 73.75% | 26.25% | 80            |
| B                           | 56.38% | 43.62% | 149           |
| C                           | 60.61% | 39.39% | 132           |
| D                           | 59.28% | 40.72% | 528           |
| Total                       | 60.29% | 39.71% | 889           |

*Table 32.1: Percentages of ALELS learners' responses and their group assessments based on each group's total. For example, for group A,  $(59/80)*100\% = 73.75\%$ .*

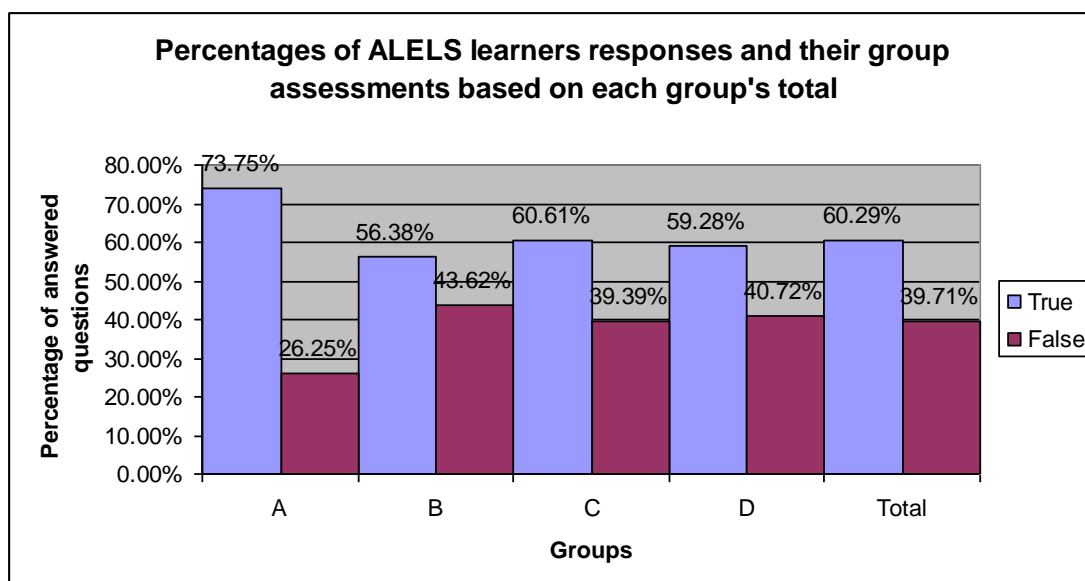
| Based on the total of all answered questions whether the answer was true or false (889) |        |        |
|---|--------|--------|
| Group   | True   | False  |
| A   | 6.64%  | 2.36%  |
| B   | 9.45%  | 7.31%  |
| C   | 9.00%  | 5.85%  |
| D   | 35.21% | 24.18% |
| Total   | 60.29% | 39.71% |

*Table 32.2: Percentages of ALELS learners' responses and their group assessments based on the total of all answered questions whether the answer was true or false. For example, for group A:  $(59/889)*100\% = 6.64\%$ .*

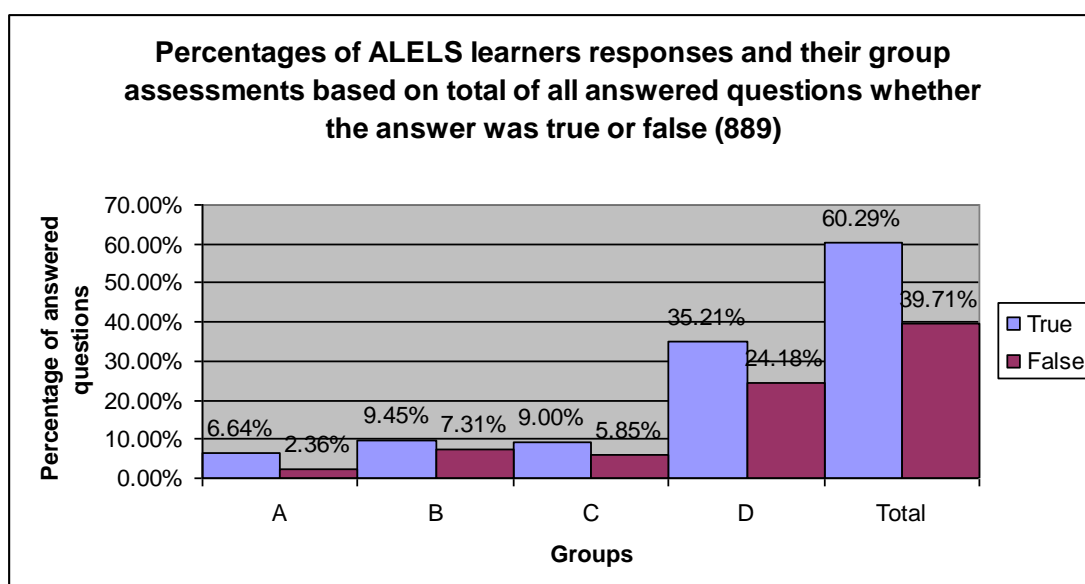
| Based on the total of all answered questions whether true or false |            |             |
|--|------------|-------------|
| Group  | True (536) | False (353) |
| A  | 11.01%     | 5.95%       |
| B  | 15.67%     | 18.41%      |
| C  | 14.93%     | 14.73%      |
| D  | 58.40%     | 60.91%      |
| Total  | 100.00%    | 100.00%     |

*Table 32.3: Percentages of ALELS learners' responses and their group assessments based on the total of all answered questions either true or false. For example, for group A:  $(59/536)*100\% = 11.01\%$ .*

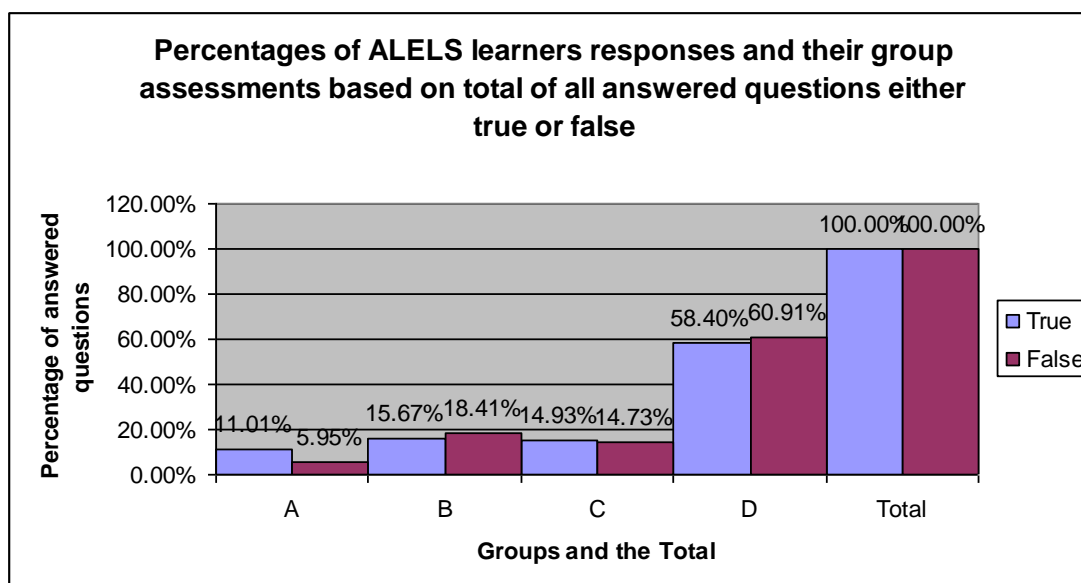
**Table 32: Percentages of ALELS learners' responses and their group assessments based on different types of totals**



**Figure 43:** (Figure from Table 32.1): Percentages of A<sub>L</sub>ELS learners' responses and their group assessments based on each group's total.



**Figure 44:** (Figure from Table 32.2): Percentages of A<sub>L</sub>ELS learners' responses and their group assessments based on the total of all answered questions whether the answer was true or false.



**Figure 45:** (Figure from Table 32.3): Percentages of ALELS learners' responses and their group assessments based on the total of all answered questions whether true or false.

#### Preliminary analysis - 2:

Per hypothesis one (sec 1.3), the correlation between learners' attempts to respond to assessments is investigated and further analysed as follows. As presented in Table 31, Table 32.1 and Figure 43, learners' learning performances is the number of questions answered correctly divided by the number of questions answered incorrectly. For example:  $536 / 353 = 1.52$ , which is  $[(1.52-1)/1.52] * 100\% = 37\%$  increase on learners' learning performance and it has increased by 1.52 times. In that regard, a detailed comparison of the learning performance based on the learner's learning activities for an adaptable e-learning system is presented in Table 33:

| Comparison of learners' learning performance for ALELS users |         |       |                        |        |
|--|---------|-------|------------------------|--------|
| Group (no. of attempted questions)                           | Answers |       | Performance comparison |        |
|  | True    | False |                        |        |
| A (0.5-9.5)  | 59      | 21    | 2.81                   | 64.41% |
| B (9.5-18.5)   | 84      | 65    | 1.29                   | 22.62% |
| C (18.5-27.5)  | 80      | 52    | 1.54                   | 35.00% |
| D (27.5-36.5)  | 313     | 215   | 1.46                   | 31.31% |
| <b>Total</b>   | 536     | 353   | 1.52                   | 34.14% |

**Table 33:** Comparison of learners' learning performance for ALELS users

Table 32.1 indicates that learner's have performed better while using A<sub>L</sub>ELS by answering questions more correctly. Group A (learners who have answered between 1 to 9 assessment questions) with 64.41%, group B (learners with 10 to 18 answered assessment questions) with 22.62%, group C (answered 19 to 27 assessment questions) with 35% and group D (those learners who have answered 28 and more assessment questions) with 31.31%. For further analysis, the activities of learners with a PELS type of e-learning system will be investigated along with their performance in attempting to answer the assessment questions in section 6.4.2.2.

#### 6.4.2.2 Investigation of learners' performance based on PELS

As stated in the introduction of section 6.4.2, there were 19 learners whose type of e-learning system was personalised ELS. Out of the 19 records of learners' registered as PELS e-learning system users, with a total of 314 attempts on 33 assessment questions, 203 (64.65%) correct attempts (true answers) were made which is much higher than the 111 (35.35%) incorrect attempts with false answers made on the same number of assessment questions.

To find any correlation between the users of PELS, the following analysis was done. A histogram is used to present the same class interval as in section 6.4.1 and Table 23, because users of the PELS are from the same group of ELS, so they will be grouped in with the same four classes of intervals as follows (*Table 34*):

| Number of PELS learners in each group |                 |                             |         |
|---------------------------------------|-----------------|-----------------------------|---------|
| Class Intervals                       |                 | No. of learners (frequency) | %       |
| Group Title                           | No. of learners |                             |         |
| A                                     | 0.5-9.5         | 8                           | 42.11%  |
| B                                     | 9.5-18.5        | 3                           | 15.79%  |
| C                                     | 18.5-27.5       | 2                           | 10.53%  |
| D                                     | 27.5-36.5       | 6                           | 31.58%  |
| <b>Total</b>                          |                 | 19                          | 100.00% |

*Table 34: Number of PELS learners in each group.*

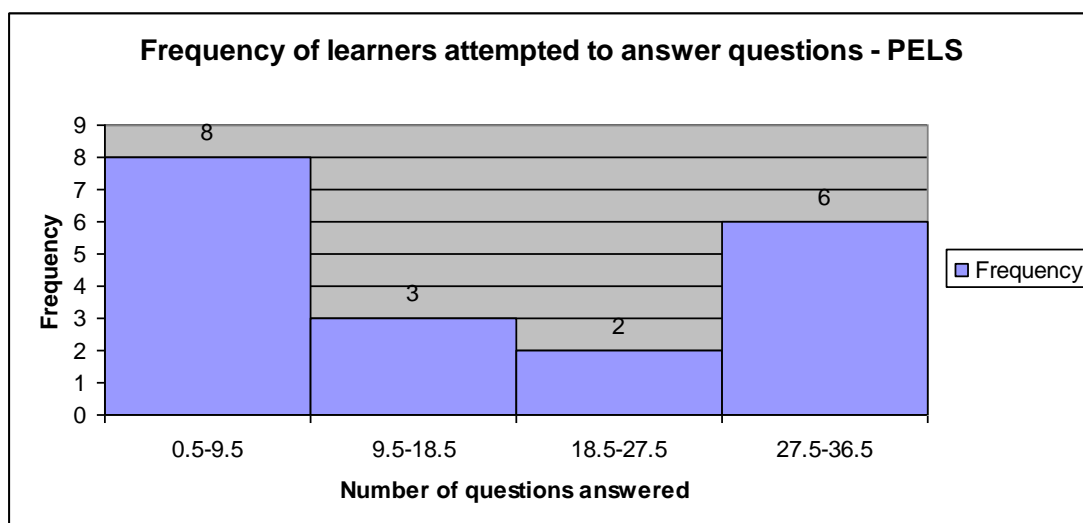


Figure 46: Figure from Table 34: Frequency of learners' attempts to answer questions – PELS.

Based on Table 34 and Figure 46, a list of relevant students in each group is provided in the following table (Table 35):

| List of PELS learners in each group based on the number of questions answered (whether true or false) |                                       |                                  |
|---|---------------------------------------|----------------------------------|
| Group Title   | List of learners' ID numbers          | Number of learners in each group |
| A   | 81, 153, 291, 332, 438, 464, 514, 568 | 8                                |
| B   | 132, 326, 450                         | 3                                |
| C   | 117, 342                              | 2                                |
| D   | 87, 269, 302, 334, 352, 530           | 6                                |

Table 35: List of PELS learners in each group based on the number of questions answered (whether true or false)

Now for all the above groups we should check for any difference between True and False responses and search for any indication of their relationship with the type of e-learning system which is personalised e-learning system. The outcome is shown on Table 36:

| <b>The number of PELS learners in each group and the number of their responses to assessments</b> |                        |                 |              |              |
|---|------------------------|-----------------|--------------|--------------|
| <b>Class Intervals</b>  |                        | <b>Answered</b> |              | <b>Total</b> |
| <b>Group title</b>  | <b>No. of learners</b> | <b>True</b>     | <b>False</b> |              |
| <b>A</b>  | 0.5-9.5                | 19              | 11           | 30           |
| <b>B</b>  | 9.5-18.5               | 24              | 19           | 43           |
| <b>C</b>  | 18.5-27.5              | 36              | 10           | 46           |
| <b>D</b>  | 27.5-36.5              | 124             | 71           | 195          |
| <b>Total</b>  |                        | 203             | 111          | 314          |

**Table 36:** *The number of PELS learners in each group and the number of their responses to assessments*

Further analysis on the data from Table 36 provides additional findings on the relevancy of the type of e-learning system (for PELS) and learners' activities on taking assessments. These comparisons are made on the basis of (i) comparing each class interval with the total number of answered questions (whether true or false) in each class (the last column from Table 36), and (ii) the total of either true (203) or false answers (111). The outcome is presented in the following tables and figures (Table 37 and Figure 47 through to Figure 49):

**Percentages of PELS learners' responses and their group assessments based on different types of total**

| <b>Based on each group's total</b> |             |              |                      |
|------------------------------------|-------------|--------------|----------------------|
| <b>Group</b>                       | <b>True</b> | <b>False</b> | <b>Group's total</b> |
| A                                  | 63.33%      | 36.67%       | 30                   |
| B                                  | 55.81%      | 44.19%       | 43                   |
| C                                  | 78.26%      | 21.74%       | 46                   |
| D                                  | 63.59%      | 36.41%       | 195                  |
| Total                              | 64.65%      | 35.35%       | 314                  |

*Table 37.1: Percentages of PELS learners' responses and their group assessments based on each group's total. For example, for group A:  $(19/30)*100\% = 63.33\%$ .*

| <b>Based on the total of all answered questions whether the answer was true or false (314)</b> |             |              |
|--|-------------|--------------|
| <b>Group</b>   | <b>True</b> | <b>False</b> |
| A  | 6.05%       | 3.50%        |
| B  | 7.64%       | 6.05%        |
| C  | 11.46%      | 3.18%        |
| D  | 39.49%      | 22.61%       |
| Total  | 64.65%      | 35.35%       |

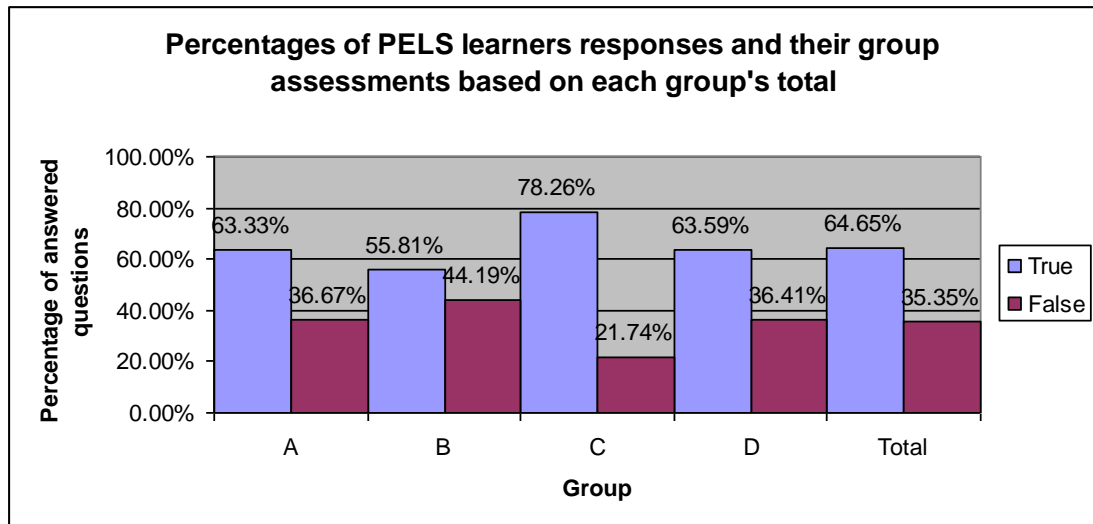
*Table 37.2: Percentages of PELS learners' responses and their group assessments based on each group's total of all answered questions whether the answer was true or false. For example, for group A:  $(19/314)*100\% = 6.05\%$ .*

| <b>Based on total of all answered questions either true or false</b> |                   |                    |
|--|-------------------|--------------------|
| <b>Group</b>   | <b>True (203)</b> | <b>False (111)</b> |
| A  | 9.36%             | 9.91%              |
| B  | 11.82%            | 17.12%             |
| C  | 17.73%            | 9.01%              |
| D  | 61.08%            | 63.96%             |
| Total  | 100.00%           | 100.00%            |

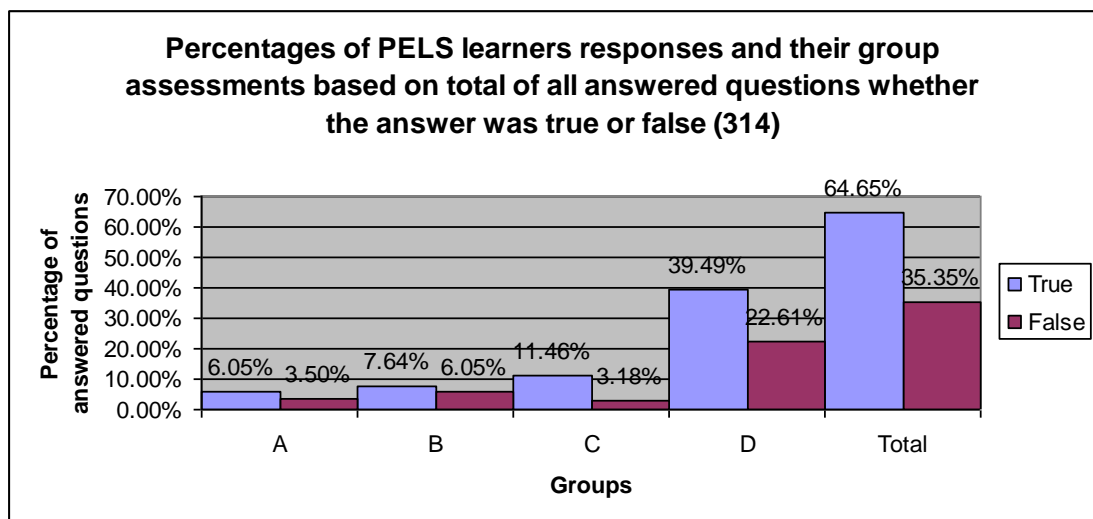
*Table 37.3: Percentages of PELS learners' responses and their group assessments based on the total of all answered questions whether true or false. For example, for group A:  $(19/203)*100\% = 9.36\%$ .*

**Table 37: Percentages of PELS learners' responses and their group assessments based on different types of totals**

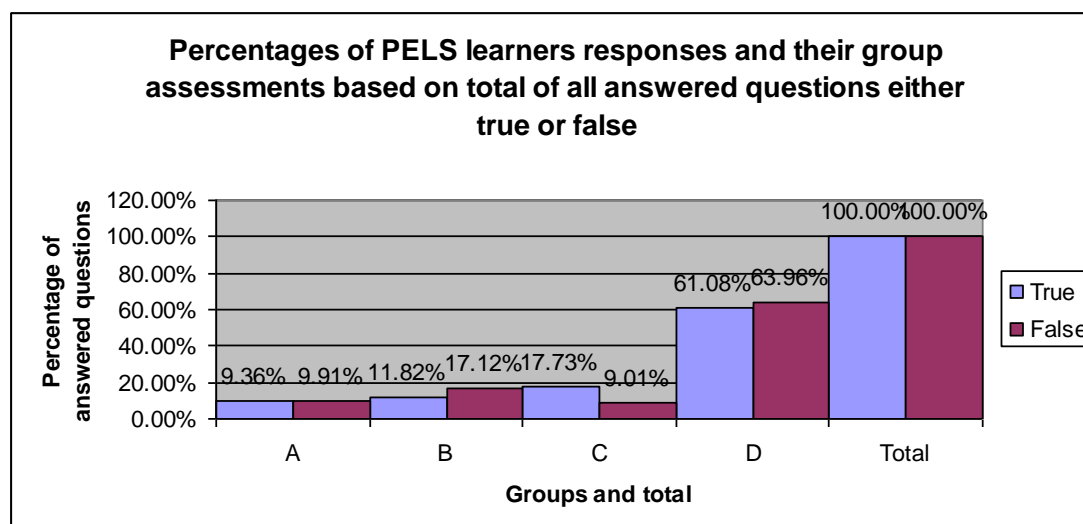




**Figure 47:** (Figure from Table 37.1): Percentages of PELS learners' responses and their group assessments based on each group's total.



**Figure 48:** (Figure from Table 37.2): Percentages of PELS learners' responses and their group assessments based on each group's total of all answered questions whether the answer was true or false.



**Figure 49:** (Figure from Table 37.3): Percentages of PELS learners' responses and their group assessments based on the total of all answered questions whether true or false.

### Observation and preliminary analysis - 3:

To investigate an indication to prove or disprove hypothesis one (section 1.3), the following analysis is presented. As per Table 37.1 and as illustrated in Figure 47, learners' responses to assessment questions have significantly (1.83 times) increased; and  $[(1.83-1)/1.83]*100\% = 45.32\%$ , which is higher than 37% of A<sub>L</sub>ELS users. Details of further analysis for all four groups are given in Table 38.

| Comparison of learners' learning performance for PELS users |         |       |                                     |        |
|---|---------|-------|-------------------------------------|--------|
| Group (no. of attempted questions)                          | Answers |       | Performance comparison (True/False) |        |
|   | True    | False |                                     |        |
| <b>A (0.5-9.5)</b>  | 19      | 11    | 1.73                                | 42.11% |
| <b>B (9.5-18.5)</b>   | 24      | 19    | 1.26                                | 20.83% |
| <b>C (18.5-27.5)</b>  | 36      | 10    | 3.60                                | 72.22% |
| <b>D (27.5-36.5)</b>  | 124     | 71    | 1.75                                | 42.74% |
| <b>Total</b>  | 203     | 111   | 1.83                                | 45.32% |

**Table 38:** Comparison of learners' learning performance for PELS users

Similar to adaptable e-learning system users, learners have performed better while using a personalised e-learning system, per Table 38, as they have answered assessment questions more correctly. The next step will be comparing the learners'

learning performance for both types of ELS (see section 6.4.2.3) and find out how much better the learners of one type of e-learning system have done compared to the other.

### 6.4.2.3 Comparison of learners' performance based on A<sub>L</sub>ELS and PELS

To simplify the interpretation of comparison of learners' activities and their learning performance in two different types of e-learning systems, records of their activities are presented in the following table (Table 39):

| Comparison of learners' performance based on type of ELS and type of answered questions |                                    |      |  |        |
|---|------------------------------------|------|--|--------|
| Type of answers   | Total number of questions answered |      | In percentage in each group of type of ELS |        |
|   | A <sub>L</sub> ELS                 | PELS | A <sub>L</sub> ELS                         | PELS   |
| Correctly (true answers)  | 536                                | 203  | 60.29%                                     | 64.65% |
| Incorrectly (false answers)   | 353                                | 111  | 39.71%                                     | 35.35% |
| Total number of answers (true or false)   | 889                                | 314  | 100%                                       | 100%   |
| Total number of learners  | 55                                 | 19   |  |        |

Table 39: Comparison of learners' performance based on type of ELSs and type of answered questions

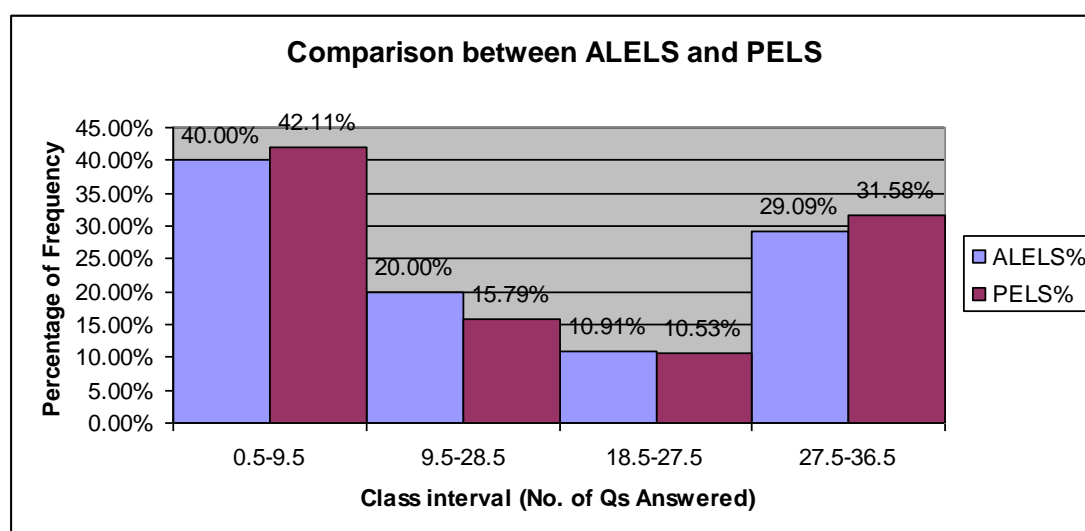
The 64.65% level of PELS users who answered the questions correctly indicates the advantage of using PELS systems on A<sub>L</sub>ELS (60.29%). This could be an indication of proving that learners who are limited to their first choice of learning method could do better in the long run and perform better than those learners who have the option and flexibility of changing the method of their learning environment.

To illustrate the comparison of the learners' activities and to learn more about their learning performance, a histogram is used for the data from section 6.4.1 and Table 23

(as they have the same users of the A<sub>L</sub>ELS and PELS). So they will be grouped in the same 4 classes as follows (Table 40 and Figure 50):

| Comparison of number of learners' performance based on the attempted questions for both types of A <sub>L</sub> ELS and PELS |                 |                                 |         |                                 |         |
|--|-----------------|---------------------------------|---------|---------------------------------|---------|
| Group Title  | Class Intervals | A <sub>L</sub> ELS              |         | PELS                            |         |
|  |                 | No. of learners (Frequency: 55) | %       | No. of learners (Frequency: 19) | %       |
| A  | 0.5-9.5         | 22                              | 40.00%  | 8                               | 42.11%  |
| B  | 9.5-28.5        | 11                              | 20.00%  | 3                               | 15.79%  |
| C  | 18.5-27.5       | 6                               | 10.91%  | 2                               | 10.53%  |
| D  | 27.5-36.5       | 16                              | 29.09%  | 6                               | 31.58%  |
| <b>Total</b>   |                 | 55                              | 100.00% | 19                              | 100.00% |

**Table 40:** Comparison of the number of learners' performance based on the attempted questions for both types of A<sub>L</sub>ELS and PELS



**Figure 50:** (Figure from Table 40) Comparison between A<sub>L</sub>ELS and PELS attempted questions in percentages.

Observations of the above data and chart (Table 40 and Figure 50) will be further investigated below and there are a few observations that have been made which present new findings that provide either prove or disprove hypothesis one (sec 1.3). Now for all the above groups (A, B, C and D) we should check for the differences between true and false responses. The outcome would be as follows (Table 41 and Table 42):

| Comparison of no. and type of answered questions between two systems |                                     |            |            |                       |            |            |
|--|-------------------------------------|------------|------------|-----------------------|------------|------------|
| Range of no. of learners in each group                               | No. of Answers (A <sub>L</sub> ELS) |            |            | No. of Answers (PELS) |            |            |
|  | True                                | False      | Total      | True                  | False      | Total      |
| A (0.5-9.5)  | 59                                  | 21         | 80         | 19                    | 11         | 30         |
| B (9.5-18.5)   | 84                                  | 65         | 149        | 24                    | 19         | 43         |
| C (18.5-27.5)  | 80                                  | 52         | 132        | 36                    | 10         | 46         |
| D (27.5-36.5)  | 313                                 | 215        | 528        | 124                   | 71         | 195        |
| <b>Total</b>   | <b>536</b>                          | <b>353</b> | <b>889</b> | <b>203</b>            | <b>111</b> | <b>314</b> |

Table 41: Comparison of number and type of answered questions between two systems

| Comparison of number and type of answered questions between two systems in the form of percentages  |        |        |  |  |  |           |      |       |   |        |        |   |        |        |   |        |        |   |        |        |       |        |        |   |  |  |  |  |  |           |      |       |   |        |        |   |        |        |   |        |        |   |        |        |       |        |        |
|---|--------|--------|--|--|--|-----------|------|-------|---|--------|--------|---|--------|--------|---|--------|--------|---|--------|--------|-------|--------|--------|---|--|--|--|--|--|-----------|------|-------|---|--------|--------|---|--------|--------|---|--------|--------|---|--------|--------|-------|--------|--------|
| <table border="1"> <thead> <tr> <th colspan="3">Based on each group's total of answered questions (A<sub>L</sub>ELS)</th> </tr> <tr> <th>For group</th> <th>True</th> <th>False</th> </tr> </thead> <tbody> <tr> <td>A</td> <td>73.75%</td> <td>26.25%</td> </tr> <tr> <td>B</td> <td>56.38%</td> <td>43.62%</td> </tr> <tr> <td>C</td> <td>60.61%</td> <td>39.39%</td> </tr> <tr> <td>D</td> <td>59.28%</td> <td>40.72%</td> </tr> <tr> <td>Total</td> <td>60.29%</td> <td>39.71%</td> </tr> </tbody> </table> |        |        | Based on each group's total of answered questions (A <sub>L</sub> ELS) |  |  | For group | True | False | A | 73.75% | 26.25% | B | 56.38% | 43.62% | C | 60.61% | 39.39% | D | 59.28% | 40.72% | Total | 60.29% | 39.71% | <table border="1"> <thead> <tr> <th colspan="3">Based on each group's total of answered questions (PELS)</th> </tr> <tr> <th>For group</th> <th>True</th> <th>False</th> </tr> </thead> <tbody> <tr> <td>A</td> <td>63.33%</td> <td>36.67%</td> </tr> <tr> <td>B</td> <td>55.81%</td> <td>44.19%</td> </tr> <tr> <td>C</td> <td>78.26%</td> <td>21.74%</td> </tr> <tr> <td>D</td> <td>63.59%</td> <td>36.41%</td> </tr> <tr> <td>Total</td> <td>64.65%</td> <td>35.35%</td> </tr> </tbody> </table> |  |  | Based on each group's total of answered questions (PELS) |  |  | For group | True | False | A | 63.33% | 36.67% | B | 55.81% | 44.19% | C | 78.26% | 21.74% | D | 63.59% | 36.41% | Total | 64.65% | 35.35% |
| Based on each group's total of answered questions (A <sub>L</sub> ELS)  |        |        |  |  |  |           |      |       |   |        |        |   |        |        |   |        |        |   |        |        |       |        |        |   |  |  |  |  |  |           |      |       |   |        |        |   |        |        |   |        |        |   |        |        |       |        |        |
| For group   | True   | False  |  |  |  |           |      |       |   |        |        |   |        |        |   |        |        |   |        |        |       |        |        |   |  |  |  |  |  |           |      |       |   |        |        |   |        |        |   |        |        |   |        |        |       |        |        |
| A   | 73.75% | 26.25% |  |  |  |           |      |       |   |        |        |   |        |        |   |        |        |   |        |        |       |        |        |   |  |  |  |  |  |           |      |       |   |        |        |   |        |        |   |        |        |   |        |        |       |        |        |
| B   | 56.38% | 43.62% |  |  |  |           |      |       |   |        |        |   |        |        |   |        |        |   |        |        |       |        |        |   |  |  |  |  |  |           |      |       |   |        |        |   |        |        |   |        |        |   |        |        |       |        |        |
| C   | 60.61% | 39.39% |  |  |  |           |      |       |   |        |        |   |        |        |   |        |        |   |        |        |       |        |        |   |  |  |  |  |  |           |      |       |   |        |        |   |        |        |   |        |        |   |        |        |       |        |        |
| D   | 59.28% | 40.72% |  |  |  |           |      |       |   |        |        |   |        |        |   |        |        |   |        |        |       |        |        |   |  |  |  |  |  |           |      |       |   |        |        |   |        |        |   |        |        |   |        |        |       |        |        |
| Total   | 60.29% | 39.71% |  |  |  |           |      |       |   |        |        |   |        |        |   |        |        |   |        |        |       |        |        |   |  |  |  |  |  |           |      |       |   |        |        |   |        |        |   |        |        |   |        |        |       |        |        |
| Based on each group's total of answered questions (PELS)  |        |        |  |  |  |           |      |       |   |        |        |   |        |        |   |        |        |   |        |        |       |        |        |   |  |  |  |  |  |           |      |       |   |        |        |   |        |        |   |        |        |   |        |        |       |        |        |
| For group   | True   | False  |  |  |  |           |      |       |   |        |        |   |        |        |   |        |        |   |        |        |       |        |        |   |  |  |  |  |  |           |      |       |   |        |        |   |        |        |   |        |        |   |        |        |       |        |        |
| A   | 63.33% | 36.67% |  |  |  |           |      |       |   |        |        |   |        |        |   |        |        |   |        |        |       |        |        |   |  |  |  |  |  |           |      |       |   |        |        |   |        |        |   |        |        |   |        |        |       |        |        |
| B   | 55.81% | 44.19% |  |  |  |           |      |       |   |        |        |   |        |        |   |        |        |   |        |        |       |        |        |   |  |  |  |  |  |           |      |       |   |        |        |   |        |        |   |        |        |   |        |        |       |        |        |
| C   | 78.26% | 21.74% |  |  |  |           |      |       |   |        |        |   |        |        |   |        |        |   |        |        |       |        |        |   |  |  |  |  |  |           |      |       |   |        |        |   |        |        |   |        |        |   |        |        |       |        |        |
| D   | 63.59% | 36.41% |  |  |  |           |      |       |   |        |        |   |        |        |   |        |        |   |        |        |       |        |        |   |  |  |  |  |  |           |      |       |   |        |        |   |        |        |   |        |        |   |        |        |       |        |        |
| Total   | 64.65% | 35.35% |  |  |  |           |      |       |   |        |        |   |        |        |   |        |        |   |        |        |       |        |        |   |  |  |  |  |  |           |      |       |   |        |        |   |        |        |   |        |        |   |        |        |       |        |        |
| Table 42.1:   |        |        | Table 42.2:  |  |  |           |      |       |   |        |        |   |        |        |   |        |        |   |        |        |       |        |        |   |  |  |  |  |  |           |      |       |   |        |        |   |        |        |   |        |        |   |        |        |       |        |        |

Let's put both outcomes of different types of ELSs without false columns into one table for comparison:

| Based on each group's total of correctly answered questions |                    |        |                    |
|---|--------------------|--------|--------------------|
| For group   | A <sub>L</sub> ELS | PELS   | Comparison         |
| A   | 73.75%             | 63.33% | A <sub>L</sub> ELS |
| B   | 56.38%             | 55.81% | A <sub>L</sub> ELS |
| C   | 60.61%             | 78.26% | PELS               |
| D   | 59.28%             | 63.59% | PELS               |
| Total   | 60.29%             | 64.65% | PELS               |

Table 42.3:

| <table border="1"> <thead> <tr> <th colspan="3">Comparison of the assessment outcome based on the total of all answered questions whether the answer was true or false for A<sub>L</sub>ELS users</th> </tr> <tr> <th>Group</th> <th>True</th> <th>False</th> </tr> </thead> <tbody> <tr> <td>A</td> <td>6.64%</td> <td>2.36%</td> </tr> <tr> <td>B</td> <td>9.45%</td> <td>7.31%</td> </tr> <tr> <td>C</td> <td>9.00%</td> <td>5.85%</td> </tr> <tr> <td>D</td> <td>35.21%</td> <td>24.18%</td> </tr> <tr> <td>Total</td> <td>60.29%</td> <td>39.71%</td> </tr> </tbody> </table> |        |        | Comparison of the assessment outcome based on the total of all answered questions whether the answer was true or false for A <sub>L</sub> ELS users |  |  | Group | True | False | A | 6.64% | 2.36% | B | 9.45% | 7.31% | C | 9.00% | 5.85% | D | 35.21% | 24.18% | Total | 60.29% | 39.71% | <table border="1"> <thead> <tr> <th colspan="3">Comparison of the assessment outcome based on the total of all answered questions whether the answer was true or false for PELS users</th> </tr> <tr> <th>Group</th> <th>True</th> <th>False</th> </tr> </thead> <tbody> <tr> <td>A</td> <td>6.05%</td> <td>3.50%</td> </tr> <tr> <td>B</td> <td>7.64%</td> <td>6.05%</td> </tr> <tr> <td>C</td> <td>11.46%</td> <td>3.18%</td> </tr> <tr> <td>D</td> <td>39.49%</td> <td>22.61%</td> </tr> <tr> <td>Total</td> <td>64.65%</td> <td>35.35%</td> </tr> </tbody> </table> |  |  | Comparison of the assessment outcome based on the total of all answered questions whether the answer was true or false for PELS users |  |  | Group | True | False | A | 6.05% | 3.50% | B | 7.64% | 6.05% | C | 11.46% | 3.18% | D | 39.49% | 22.61% | Total | 64.65% | 35.35% |
|--|--------|--------|---|--|--|-------|------|-------|---|-------|-------|---|-------|-------|---|-------|-------|---|--------|--------|-------|--------|--------|---|--|--|---|--|--|-------|------|-------|---|-------|-------|---|-------|-------|---|--------|-------|---|--------|--------|-------|--------|--------|
| Comparison of the assessment outcome based on the total of all answered questions whether the answer was true or false for A <sub>L</sub> ELS users  |        |        |   |  |  |       |      |       |   |       |       |   |       |       |   |       |       |   |        |        |       |        |        |   |  |  |   |  |  |       |      |       |   |       |       |   |       |       |   |        |       |   |        |        |       |        |        |
| Group  | True   | False  |   |  |  |       |      |       |   |       |       |   |       |       |   |       |       |   |        |        |       |        |        |   |  |  |   |  |  |       |      |       |   |       |       |   |       |       |   |        |       |   |        |        |       |        |        |
| A  | 6.64%  | 2.36%  |   |  |  |       |      |       |   |       |       |   |       |       |   |       |       |   |        |        |       |        |        |   |  |  |   |  |  |       |      |       |   |       |       |   |       |       |   |        |       |   |        |        |       |        |        |
| B  | 9.45%  | 7.31%  |   |  |  |       |      |       |   |       |       |   |       |       |   |       |       |   |        |        |       |        |        |   |  |  |   |  |  |       |      |       |   |       |       |   |       |       |   |        |       |   |        |        |       |        |        |
| C  | 9.00%  | 5.85%  |   |  |  |       |      |       |   |       |       |   |       |       |   |       |       |   |        |        |       |        |        |   |  |  |   |  |  |       |      |       |   |       |       |   |       |       |   |        |       |   |        |        |       |        |        |
| D  | 35.21% | 24.18% |   |  |  |       |      |       |   |       |       |   |       |       |   |       |       |   |        |        |       |        |        |   |  |  |   |  |  |       |      |       |   |       |       |   |       |       |   |        |       |   |        |        |       |        |        |
| Total  | 60.29% | 39.71% |   |  |  |       |      |       |   |       |       |   |       |       |   |       |       |   |        |        |       |        |        |   |  |  |   |  |  |       |      |       |   |       |       |   |       |       |   |        |       |   |        |        |       |        |        |
| Comparison of the assessment outcome based on the total of all answered questions whether the answer was true or false for PELS users  |        |        |   |  |  |       |      |       |   |       |       |   |       |       |   |       |       |   |        |        |       |        |        |   |  |  |   |  |  |       |      |       |   |       |       |   |       |       |   |        |       |   |        |        |       |        |        |
| Group  | True   | False  |   |  |  |       |      |       |   |       |       |   |       |       |   |       |       |   |        |        |       |        |        |   |  |  |   |  |  |       |      |       |   |       |       |   |       |       |   |        |       |   |        |        |       |        |        |
| A  | 6.05%  | 3.50%  |   |  |  |       |      |       |   |       |       |   |       |       |   |       |       |   |        |        |       |        |        |   |  |  |   |  |  |       |      |       |   |       |       |   |       |       |   |        |       |   |        |        |       |        |        |
| B  | 7.64%  | 6.05%  |   |  |  |       |      |       |   |       |       |   |       |       |   |       |       |   |        |        |       |        |        |   |  |  |   |  |  |       |      |       |   |       |       |   |       |       |   |        |       |   |        |        |       |        |        |
| C  | 11.46% | 3.18%  |   |  |  |       |      |       |   |       |       |   |       |       |   |       |       |   |        |        |       |        |        |   |  |  |   |  |  |       |      |       |   |       |       |   |       |       |   |        |       |   |        |        |       |        |        |
| D  | 39.49% | 22.61% |   |  |  |       |      |       |   |       |       |   |       |       |   |       |       |   |        |        |       |        |        |   |  |  |   |  |  |       |      |       |   |       |       |   |       |       |   |        |       |   |        |        |       |        |        |
| Total  | 64.65% | 35.35% |   |  |  |       |      |       |   |       |       |   |       |       |   |       |       |   |        |        |       |        |        |   |  |  |   |  |  |       |      |       |   |       |       |   |       |       |   |        |       |   |        |        |       |        |        |
| Table 42.4:  |        |        | Table 42.5:   |  |  |       |      |       |   |       |       |   |       |       |   |       |       |   |        |        |       |        |        |   |  |  |   |  |  |       |      |       |   |       |       |   |       |       |   |        |       |   |        |        |       |        |        |

| Comparison of the assessment outcome based on the total of all questions answered correctly |                    |        |                    |
|---|--------------------|--------|--------------------|
| Group   | A <sub>L</sub> ELS | PELS   | Comparison         |
| A   | 6.64%              | 6.05%  | A <sub>L</sub> ELS |
| B   | 9.45%              | 7.64%  | A <sub>L</sub> ELS |
| C   | 9.00%              | 11.46% | PELS               |
| D   | 35.21%             | 39.49% | PELS               |
| Total   | 60.29%             | 64.65% | PELS               |

Table 42.6:

| Based on the total of all answered questions either true or false (A <sub>L</sub> ELS) |         |         |
|--|---------|---------|
| For group  | True    | False   |
| A  | 11.01%  | 5.95%   |
| B  | 15.67%  | 18.41%  |
| C  | 14.93%  | 14.73%  |
| D  | 58.40%  | 60.91%  |
| Total  | 100.00% | 100.00% |

Table 42.7:

| Based on the total of all answered questions whether true or false (PELS) |         |         |
|---|---------|---------|
| For group   | True    | False   |
| A   | 9.36%   | 9.91%   |
| B   | 11.82%  | 17.12%  |
| C   | 17.73%  | 9.01%   |
| D   | 61.08%  | 63.96%  |
| Total   | 100.00% | 100.00% |

Table 42.8:

| Based on the total of all answered questions whether true or false |                    |         |                    |
|--|--------------------|---------|--------------------|
| For group  | A <sub>L</sub> ELS | PELS    | Comparison         |
| A  | 11.01%             | 9.36%   | A <sub>L</sub> ELS |
| B  | 15.67%             | 11.82%  | A <sub>L</sub> ELS |
| C  | 14.93%             | 17.73%  | PELS               |
| D  | 58.40%             | 61.08%  | PELS               |
| Total  | 100.00%            | 100.00% |                    |

Table 42.9:

**Table 42:** Comparison of the number and type of answered questions between two systems in the form of percentages

### **Observation:**

By comparing the data in Table 42.3, Table 42.6 and Table 42.9 there are indications as to which users of personalised e-learning systems have performed better in doing assessments as the number of their attempts increased:

- i) Data from Table 42.3 regarding learners' interaction with two types of ELS indicate the advantages of using PEELS to A<sub>L</sub>ELS when the number of attempts to answer assessment questions correctly increases based on the group's total of answered questions.

- ii) Data from Table 42.6 present the comparison of the assessment outcome based on the total of all answered questions for all correctly answered questions; and it is clear by the increase in the number of responses that the personalised e-learning system shows a significant advantage.
- iii) Data from Table 42.9 clearly shows the advantages of using a personalised e-learning system to the adaptable type of e-learning system, when the number of responses increases.

The above results clearly show the advantages of using PELS to the A<sub>L</sub>ELS, when the number of responses is increased in each group. To further understand these elements, it is essential to examine the possibility of any relevancy of the type of questions to the type of e-learning systems in use. This analysis is carried out in section 6.4.3.

### **6.4.3 Analysis of records based on RCU**

Further to the analysis of the data gathered from learners' activities, and as one of the main objectives of this research, the investigation to find any relationship between the type of content material and their effects on the learner's learning performances (section 2.8) is presented as follows. In this section, analysis of the learners' performance based on 33 assessment questions of type recall (R – 7 questions), competency (C – 16 questions) and understanding (U – 10 questions) for both types of e-learning systems has been done (sections 4.9 and 5.5). The total number of responses to those questions is presented in the following table (Table 43):

| Assessment (not practice) type of questions and their responses |                              |            |             |               |               |                                  |                    |            |            |                      |            |            |
|---|------------------------------|------------|-------------|---------------|---------------|----------------------------------|--------------------|------------|------------|----------------------|------------|------------|
| Question ID   | Number of answered questions |            |             |               |               | Type and number of answers (RCU) |                    |            |            |                      |            |            |
|   | In quantity                  |            |             | In %          |               | All types                        | Correctly answered |            |            | Incorrectly answered |            |            |
|   | True                         | False      | Total       | True          | False         |                                  | R                  | C          | U          | R                    | C          | U          |
| 8   | 15                           | 10         | 25          | 60%           | 40%           | C                                | 0                  | 15         | 0          | 0                    | 10         | 0          |
| 15  | 10                           | 15         | 25          | 40%           | 60%           | C                                | 0                  | 10         | 0          | 0                    | 15         | 0          |
| 16  | 12                           | 13         | 25          | 48%           | 52%           | C                                | 0                  | 12         | 0          | 0                    | 13         | 0          |
| 17  | 12                           | 12         | 24          | 50%           | 50%           | C                                | 0                  | 12         | 0          | 0                    | 12         | 0          |
| 18  | 11                           | 13         | 24          | 46%           | 54%           | C                                | 0                  | 11         | 0          | 0                    | 13         | 0          |
| 19  | 14                           | 10         | 24          | 58%           | 42%           | C                                | 0                  | 14         | 0          | 0                    | 10         | 0          |
| 20  | 11                           | 13         | 24          | 46%           | 54%           | C                                | 0                  | 11         | 0          | 0                    | 13         | 0          |
| 21  | 12                           | 12         | 24          | 50%           | 50%           | C                                | 0                  | 12         | 0          | 0                    | 12         | 0          |
| 22  | 8                            | 16         | 24          | 33%           | 67%           | C                                | 0                  | 8          | 0          | 0                    | 16         | 0          |
| 23  | 11                           | 13         | 24          | 46%           | 54%           | C                                | 0                  | 11         | 0          | 0                    | 13         | 0          |
| 27  | 51                           | 20         | 71          | 72%           | 28%           | U                                | 0                  | 0          | 51         | 0                    | 0          | 20         |
| 29  | 60                           | 5          | 65          | 92%           | 8%            | U                                | 0                  | 0          | 60         | 0                    | 0          | 5          |
| 32  | 25                           | 35         | 60          | 42%           | 58%           | R                                | 25                 | 0          | 0          | 35                   | 0          | 0          |
| 33  | 47                           | 12         | 59          | 80%           | 20%           | R                                | 47                 | 0          | 0          | 12                   | 0          | 0          |
| 36  | 44                           | 7          | 51          | 86%           | 14%           | R                                | 44                 | 0          | 0          | 7                    | 0          | 0          |
| 37  | 34                           | 17         | 51          | 67%           | 33%           | U                                | 0                  | 0          | 34         | 0                    | 0          | 17         |
| 40  | 28                           | 17         | 45          | 62%           | 38%           | U                                | 0                  | 0          | 28         | 0                    | 0          | 17         |
| 41  | 11                           | 34         | 45          | 24%           | 76%           | U                                | 0                  | 0          | 11         | 0                    | 0          | 34         |
| 43  | 14                           | 28         | 42          | 33%           | 67%           | U                                | 0                  | 0          | 14         | 0                    | 0          | 28         |
| 45  | 20                           | 25         | 45          | 44%           | 56%           | R                                | 20                 | 0          | 0          | 25                   | 0          | 0          |
| 46  | 35                           | 4          | 39          | 90%           | 10%           | U                                | 0                  | 0          | 35         | 0                    | 0          | 4          |
| 47  | 34                           | 5          | 39          | 87%           | 13%           | U                                | 0                  | 0          | 34         | 0                    | 0          | 5          |
| 50  | 33                           | 4          | 37          | 89%           | 11%           | R                                | 33                 | 0          | 0          | 4                    | 0          | 0          |
| 51  | 30                           | 8          | 38          | 79%           | 21%           | R                                | 30                 | 0          | 0          | 8                    | 0          | 0          |
| 55  | 24                           | 11         | 35          | 69%           | 31%           | C                                | 0                  | 24         | 0          | 0                    | 11         | 0          |
| 56  | 6                            | 29         | 35          | 17%           | 83%           | C                                | 0                  | 6          | 0          | 0                    | 29         | 0          |
| 60  | 11                           | 19         | 30          | 37%           | 63%           | C                                | 0                  | 11         | 0          | 0                    | 19         | 0          |
| 61  | 19                           | 11         | 30          | 63%           | 37%           | C                                | 0                  | 19         | 0          | 0                    | 11         | 0          |
| 64  | 21                           | 10         | 31          | 68%           | 32%           | C                                | 0                  | 21         | 0          | 0                    | 10         | 0          |
| 65  | 20                           | 11         | 31          | 65%           | 35%           | C                                | 0                  | 20         | 0          | 0                    | 11         | 0          |
| 77  | 19                           | 8          | 27          | 70%           | 30%           | U                                | 0                  | 0          | 19         | 0                    | 0          | 8          |
| 78  | 18                           | 9          | 27          | 67%           | 33%           | U                                | 0                  | 0          | 18         | 0                    | 0          | 9          |
| 79  | 19                           | 8          | 27          | 70%           | 30%           | R                                | 19                 | 0          | 0          | 8                    | 0          | 0          |
| <b>Total</b>  | <b>739</b>                   | <b>464</b> | <b>1203</b> | <b>61.43%</b> | <b>38.57%</b> |                                  | <b>218</b>         | <b>217</b> | <b>304</b> | <b>99</b>            | <b>218</b> | <b>147</b> |

**Table 43: Assessment (not practice) type of questions and their responds**

As seen in the table above, 61.43% ( $739/1203 \times 100\% = 61.43\%$ ) of responses are correct compared to 38.57% ( $464/1203 \times 100\% = 38.57\%$ ) incorrectly answered questions. The 37.21% ( $(739-464)/739 \times 100\% = 37.21\%$ ) better response on the number of answered questions could indicate that an e-learning system generally can



support the transfer of knowledge and increase performance; however, further analysis is needed to clarify this statement.

In this section analysis has been done on the basis of:

- i) Analysis of records of all responses from ELS users based on RCU (Recall, Competency and Understanding types of assessment question)
- ii) Analysis of records of responses of A<sub>L</sub>ELS users based on RCU
- iii) Analysis of records of responses of PELS users based on RCU
- iv) Comparison of analysis of records of responses from A<sub>L</sub>ELS and PELS users based on groups (classified frequencies) and types of question (RCU).

### 6.4.3.1 Analysis of records of all responses from ELS users based on RCU

Analysis of learners' performance based on Recall, Competency and Understanding (RCU) types of question (33 Qs) for both types of e-learning systems is presented in the tables below. Table 44, Table 45 and Table 46 present a comparison between both adaptable and personalised e-learning system users in three different forms: (i) total responses, (ii) correctly answered responses and (iii) incorrectly answered assessment questions.

| <b>Comparison of learners' responses to RCU type of questions based on both ELSs</b> |                                  |             |             |             |              |                |
|--|----------------------------------|-------------|-------------|-------------|--------------|----------------|
| <b>Type of Questions</b>   | <b>No. of questions answered</b> |             |             |             |              |                |
|  | <b>A<sub>L</sub>ELS</b>          |             | <b>PELS</b> |             | <b>Total</b> |                |
|  | <b>No.</b>                       | <b>%</b>    | <b>No.</b>  | <b>%</b>    | <b>No.</b>   | <b>%</b>       |
| Recall (R)   | 232                              | 26.10%      | 85          | 27.07%      | 317          | 26.35%         |
| Competency (C)   | 325                              | 36.56%      | 110         | 35.03%      | 435          | 36.16%         |
| Understanding (U)  | 332                              | 37.35%      | 119         | 37.90%      | 451          | 37.49%         |
|  |                                  |             |             |             |              |                |
| <b>Total</b>   | <b>889</b>                       | <b>100%</b> | <b>314</b>  | <b>100%</b> | <b>1203</b>  | <b>100.00%</b> |

**Table 44:** Comparison of learners' responses to RCU type of questions based on both ELSs

True answers

| <b>Comparison of learners' correct responses to RCU type of questions based on two ELSs</b> |  |             |             |             |              |             |
|---|--|-------------|-------------|-------------|--------------|-------------|
| <b>Type of Questions</b>  | <b>No. of questions answered correctly</b> |             |             |             |              |             |
|   | <b>A<sub>L</sub>ELS</b>                    |             | <b>PELS</b> |             | <b>Total</b> |             |
|   | <b>No.</b>                                 | <b>%</b>    | <b>No.</b>  | <b>%</b>    | <b>No.</b>   | <b>%</b>    |
| Recall (R)  | 156  | 29.10%      | 62          | 30.54%      | 218          | 29.50%      |
| Competency (C)  | 158  | 29.48%      | 59          | 29.06%      | 217          | 29.36%      |
| Understanding (U)   | 222  | 41.42%      | 82          | 40.39%      | 304          | 41.14%      |
|   |  |             |             |             |              |             |
| <b>Total</b>  | <b>536</b>                                 | <b>100%</b> | <b>203</b>  | <b>100%</b> | <b>739</b>   | <b>100%</b> |

**Table 45:** Comparison of learners' correct responses to RCU type of questions based on two ELSs

False answers

| <b>Comparison of learners' incorrect responses to RCU type of questions based on two ELSs</b> |                                  |          |             |          |              |          |
|---|----------------------------------|----------|-------------|----------|--------------|----------|
| <b>Type of Questions</b>  | <b>No. of questions answered</b> |          |             |          |              |          |
|   | <b>A<sub>L</sub>ELS</b>          |          | <b>PELS</b> |          | <b>Total</b> |          |
|   | <b>No.</b>                       | <b>%</b> | <b>No.</b>  | <b>%</b> | <b>No.</b>   | <b>%</b> |
| Recall (R)  | 76                               | 21.53%   | 23          | 20.72%   | 99           | 21.34%   |
| Competency (C)  | 167                              | 47.31%   | 51          | 45.95%   | 218          | 46.98%   |
| Understanding (U)   | 110                              | 31.16%   | 37          | 33.33%   | 147          | 31.68%   |
|   |                                  |          |             |          |              |          |
| Total   | 353                              | 100%     | 111         | 100%     | 464          | 100%     |

**Table 46:** Comparison of learners' incorrect responses to RCU type of questions based on two ELSs

Based on the data from Table 44, learners using PEELS have performed better on their recall (R – 27.07% compared to 26.10%) and understanding (U – 37.90% compared to 37.35%) types of assessment than A<sub>L</sub>ELS users, who hold a better performance for competency (C – 36.56% compared to 35.03%) types of assessment. However, if we compare both types of system from only the correctly answered assessment questions' perspective, new findings show up (Table 45), which are: learners with PEELS have performed better on recall (R – 30.54% compared to 29.10%) types of assessment question than competency (C – 29.06% compared to 29.48%) and understanding (U – 40.39% compared to 41.42%) types of assessment question.

These new findings are further analysed in section 6.4.3.2, to learn about any indications of relevancy between these data (types of assessment question) and the number of answers. In addition to the discussion, the principle of this investigation would be based on different types of assessment question and the number of attempts taken by learners of both types of e-learning system (adaptable e-learning system [A<sub>L</sub>ELS] and personalised e-learning system [PEELS]):

**(i) Analysis of records of responses of A<sub>L</sub>ELS users based on RCU**

Table 47 presents data on the outcome of finding any relationship between learners' responses on assessment questions and the number of responses for an adaptable e-learning system:

| <b>A<sub>L</sub>ELS users and comparison of their activities based on different groups and types of assessment questions (RCU)</b> |                        |  |          |          |              |  |          |          |              |
|--|------------------------|--|----------|----------|--------------|--|----------|----------|--------------|
| <b>Groups</b>  | <b>Class Intervals</b> | <b>Number of questions answered in different types</b> |          |          |              | <b>Percentage of no. of questions answered based on total of R, C &amp; U separately</b><br><i>(e.g. Group A: R/(total for R) = 21/156 = 13.46%)</i> |          |          |              |
|  |                        | <b>R</b>   | <b>C</b> | <b>U</b> | <b>Total</b> | <b>R</b>   | <b>C</b> | <b>U</b> | <b>Total</b> |
| A  | 0.5-9.5                | 21   | 0        | 38       | 59           | 13.46%   | 0.00%    | 17.12%   | 11.01%       |
| B  | 9.5-28.5               | 35   | 5        | 44       | 84           | 22.44%   | 3.16%    | 19.82%   | 15.67%       |
| C  | 18.5-27.5              | 27   | 16       | 37       | 80           | 17.31%   | 10.13%   | 16.67%   | 14.93%       |
| D  | 27.5-36.5              | 73   | 137      | 103      | 313          | 46.79%   | 86.71%   | 46.40%   | 58.40%       |
| Total  |                        | 156  | 158      | 222      | 536          | 100.00%  | 100.00%  | 100.00%  | 100.00%      |

**Table 47:** *ALELS users and comparison of their activities based on different groups and types of questions (RCU)*

The outcomes has been analysed in section 6.4.3.2 (below) in comparison to personalised e-learning system users.

**(ii) Analysis of records of responses of PELS users based on RCU**

Table 48 (below) presents data on the relationship between learners' responses to assessment questions and the number of responses for personalised e-learning systems:

| <b>PELS users and analysis of their activities based on different groups and types of questions</b> |                        |  |          |          |              |  |          |          |              |
|---|------------------------|--|----------|----------|--------------|--|----------|----------|--------------|
| <b>Groups</b>   | <b>Class Intervals</b> | <b>Number of questions answered in different types</b> |          |          |              | <b>Percentage of no. of questions answered based on total of R, C &amp; U separately</b><br><i>(e.g. Group A: R/(total for R) = 7/62 = 11.29%)</i> |          |          |              |
|   |                        | <b>R</b>   | <b>C</b> | <b>U</b> | <b>Total</b> | <b>R</b>   | <b>C</b> | <b>U</b> | <b>Total</b> |
| A   | 0.5-9.5                | 7  | 0        | 12       | 19           | 11.29%   | 0.00%    | 14.63%   | 9.36%        |
| B   | 9.5-28.5               | 9  | 1        | 14       | 24           | 14.52%   | 1.69%    | 17.07%   | 11.82%       |
| C   | 18.5-27.5              | 13   | 9        | 14       | 36           | 20.97%   | 15.25%   | 17.07%   | 17.73%       |
| D   | 27.5-36.5              | 33   | 49       | 42       | 124          | 53.23%   | 83.05%   | 51.22%   | 61.08%       |
| Total   |                        | 62   | 59       | 82       | 203          | 100.00%  | 100.00%  | 100.00%  | 100.00%      |

**Table 48:** *PELS users and analysis of their activities based on different groups and types of questions*

The outcome has been analysed in section 6.4.3.2 below in comparison to adaptable e-learning system users to seek any indication of the type of e-learning system with the number of assessment questions answered, and how the learners have performed.

### 6.4.3.2 Comparison of analysis of records of responses from A<sub>L</sub>ELS and PELS users based on groups and types of questions (RCU)

As learners have taken different types of assessment questions categorised by recall (R), competency (C) and understanding (U) types, the comparison of their activities within two different types of e-learning system (adaptable and personalised e-learning systems) have interesting results, as highlighted in the following tables, which would confirm hypothesis two in section 1.3 (the relevancy of different types of e-learning systems with learners' performance).

| <b>A<sub>L</sub>ELS and PELS users' assessment outcome and comparison of their activities based on different groups and types of questions (RCU)</b> |                 |                    |        |        |        |        |        |        |        |  |
|--|-----------------|--------------------|--------|--------|--------|--------|--------|--------|--------|--|
| <i>Percentage of no. of questions answered based on the total of R, C &amp; U separately</i>   |                 |                    |        |        |        |        |        |        |        |  |
| Groups   | Class Intervals | A <sub>L</sub> ELS |        |        |        | PELS   |        |        |        |  |
|  |                 | R                  | C      | U      | Total  | R      | C      | U      | Total  |  |
| A  | 0.5-9.5         | 13.46%             | 0.00%  | 17.12% | 11.01% | 11.29% | 0.00%  | 14.63% | 9.36%  |  |
| B  | 9.5-28.5        | 22.44%             | 3.16%  | 19.82% | 15.67% | 14.52% | 1.69%  | 17.07% | 11.82% |  |
| C  | 18.5-27.5       | 17.31%             | 10.13% | 16.67% | 14.93% | 20.97% | 15.25% | 17.07% | 17.73% |  |
| D  | 27.5-36.5       | 46.79%             | 86.71% | 46.40% | 58.40% | 53.23% | 83.05% | 51.22% | 61.08% |  |

**Table 49:** *A<sub>L</sub>ELS and PELS users' assessment outcome and comparison of their activities based on different groups and types of questions (RCU)*

**Comparison of ALELS and PELS users' assessment outcome based on different frequencies of learners in each group and type of questions separately (RCU)**

| The comparison for Recall (R) types of question |                    |        |                    |        |
|---|--------------------|--------|--------------------|--------|
| Group   | A <sub>L</sub> ELS | PELS   | Comparison         |        |
|   |                    |        | Type               | In %   |
| A (0.5-9.5)                                     | 73.75%             | 63.33% | A <sub>L</sub> ELS | 16.45% |
| B (9.5-18.5)                                    | 56.38%             | 55.81% | A <sub>L</sub> ELS | 1.02%  |
| C (18.5-27.5)                                   | 60.61%             | 78.26% | PELS               | 22.55% |
| D (27.5-36.5)                                   | 59.28%             | 63.59% | PELS               | 6.78%  |

Table 50.1

| The comparison for Competency (C) types of question |                    |        |                    |        |
|---|--------------------|--------|--------------------|--------|
| Group   | A <sub>L</sub> ELS | PELS   | Comparison         |        |
|   |                    |        | Type               | In %   |
| A (0.5-9.5)   | 0.00%              | 0.00%  | -                  | -      |
| B (9.5-18.5)  | 3.16%              | 1.69%  | A <sub>L</sub> ELS | 86.98% |
| C (18.5-27.5)                                       | 10.13%             | 15.25% | PELS               | 33.57% |
| D (27.5-36.5)                                       | 86.71%             | 83.05% | A <sub>L</sub> ELS | 4.41%  |

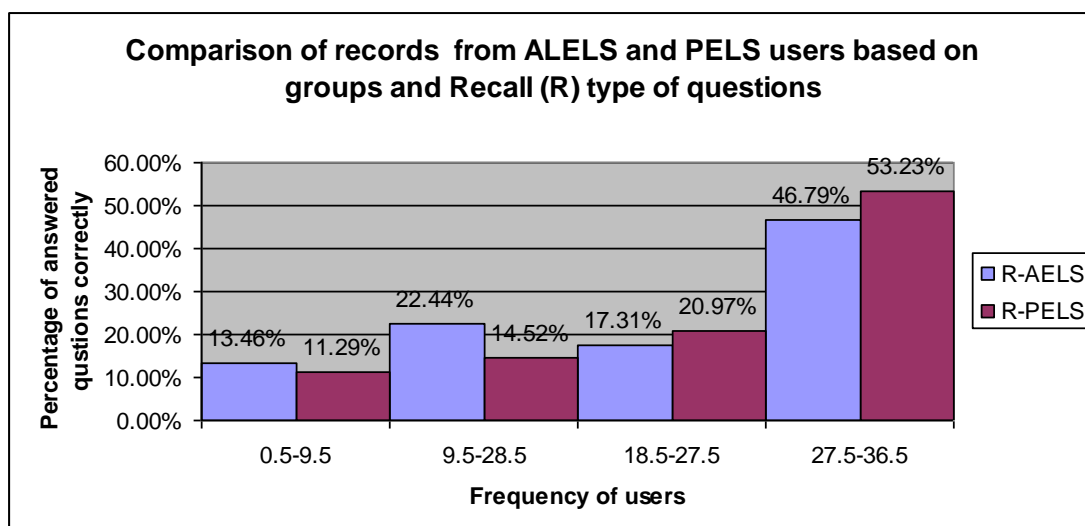
Table 50.2

| The comparison for Understanding (U) types of question |                    |        |            |                    |
|--|--------------------|--------|------------|--------------------|
| Group  | A <sub>L</sub> ELS | PELS   | Comparison |                    |
|  |                    |        | In %       | Type               |
| A (0.5-9.5)  | 17.12%             | 14.63% | 17.02%     | A <sub>L</sub> ELS |
| B (9.5-18.5)   | 19.82%             | 17.07% | 16.11%     | A <sub>L</sub> ELS |
| C (18.5-27.5)  | 16.67%             | 17.07% | 2.34%      | PELS               |
| D (27.5-36.5)  | 46.40%             | 51.22% | 9.41%      | PELS               |

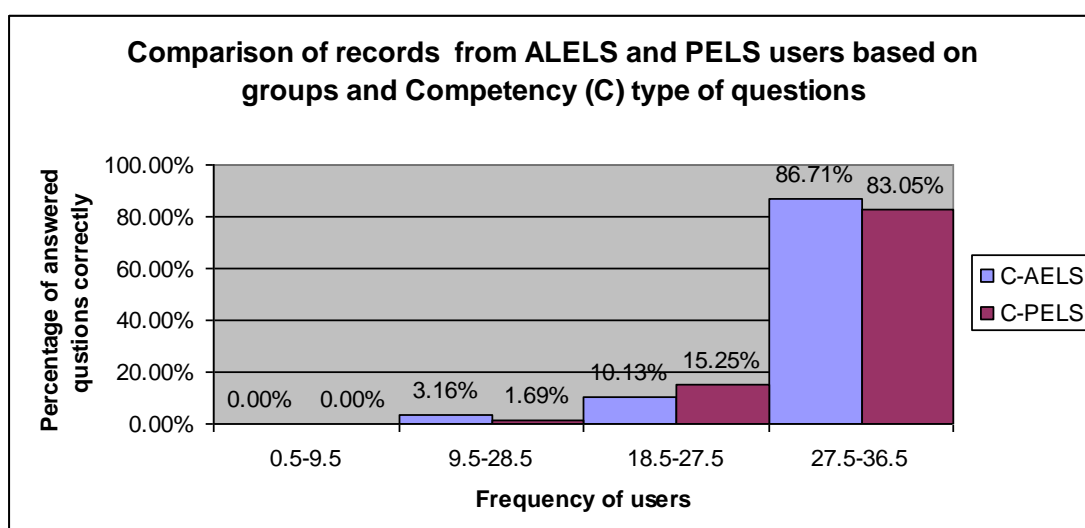
Table 50.3

**Table 50: Comparison of ALELS and PELS users' assessment outcome based on different frequencies of learners in each group and types of question separately (RCU)**

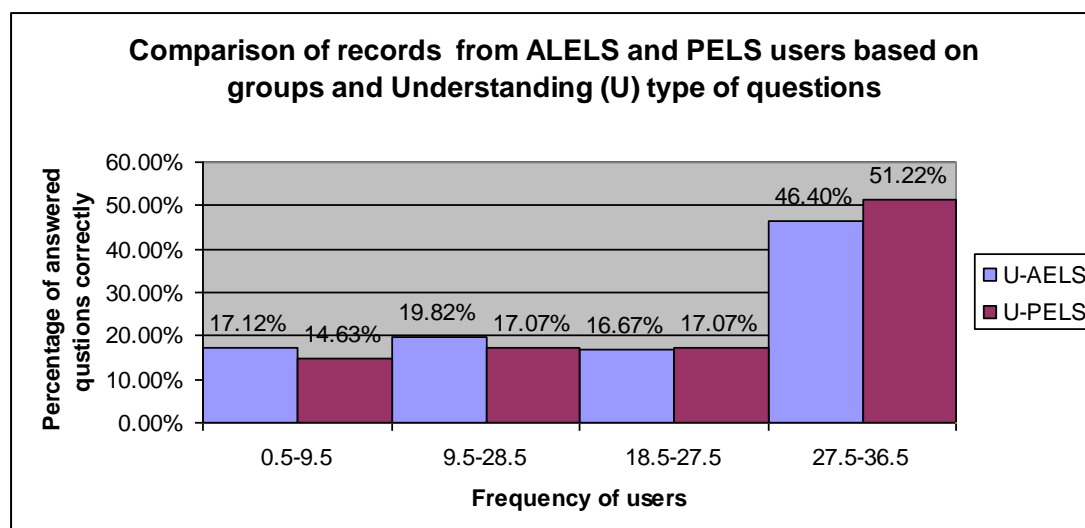
The following charts (Figure 51, Figure 52 and Figure 53) provide a visual representation of the tables above (Table 50):



**Figure 51:** (Figure from Table 50.1) Comparison of records from A<sub>L</sub>ELS and PELS users based on groups and recall (R) types of question.



**Figure 52:** (Figure from Table 50.2) Comparison of records from A<sub>L</sub>ELS and PELS users based on groups and competency (C) types of question.



**Figure 53:** (Figure from Table 50.3) Comparison of records from ALELS and PELS users based on groups and understanding (U) types of question.

**Observation:**

By comparing the number of correctly answered assessment questions on both types of questions (as presented in Table 50), it is clear that recall (R) – with 22.55% for group C (19 – 27 attempts) and 6.78% for group D (28 – 36 attempts) – and understanding (U) types of questions – with 2.34% for group C and 9.41% for group D – favour the personalised type of e-learning system more than the adaptable e-learning system when the number of users and their attempts to take assessments increase. Furthermore, per the observation and analysis above, the situation has changed for the learners’ learning performance while answering competency typed of assessment question. The first group “A” (1 – 9 attempts) does not include anything, which indicates that either no students have started to work on any competency type of assessment, or whenever they started to take that assessment on that topic, they have gone through all stages of completing that module, and attempted at least 10 questions (group B – 10 – 18 attempts).



On the other hand, for the first three groups on the competency (C) type of question, the same presumption could apply. But the situation changes when the number of attempts to take assessments rises (the fourth group). These could indicate the flexibility of the learning environment and the opportunity for learners to take advantage of having access to all types of e-learning system in an adaptable e-learning system rather than a fixed type of e-learning environment in a personalised ELS with no option to change their learning preferences. In addition, the irregularity of the outcome of competency questions could indicate the level of flexibility of human-computer-interaction (HCI) factors on the type of systems being used, which is an indication of proof of hypothesis (section 2.8). In an adaptable e-learning system, learners could have (i) used, or even (ii) got the sense of having access to, the flexibility of the environment and as such, learners' learning performance is 4.41% better than PELS users. These outcomes could be investigated further when there are more records produced by an increased number of (i) active learners registered to the system, and (ii) topics with more questions of type recall (R), competency (C) and understanding (U).

If we take the median of the frequency scale for each group to find any relationship between the number of attempts on the assessment question and the correct response between, and so to prevent any misinterpretation of data, a scatter graph is drawn to make sure that we can calculate linear-based correlation coefficient measures and can take the  $Y=a+bX$  equation. The section below presents a method for finding the correlation coefficient for each type of assessment questions and the system those assessment have taken. As the outcome of measuring the linear-based correlation coefficient is a number between -1 and +1, they represent different types of

relationship between those groups of data. For example, if the outcome is +1 it represents a perfect positive correlation between those groups of data; however, if the correlation coefficient was 0, then it would suggest that there is absolutely no association between any groups of data. Furthermore, the value for a correlation coefficient between 0 and +1 would represent the degree of correlation between those two groups and the tightness it gets to +1, which means the association is stronger. For the relationship between 0 and -1, the same description for 0 to +1 applies as above but in the opposite direction (negative).

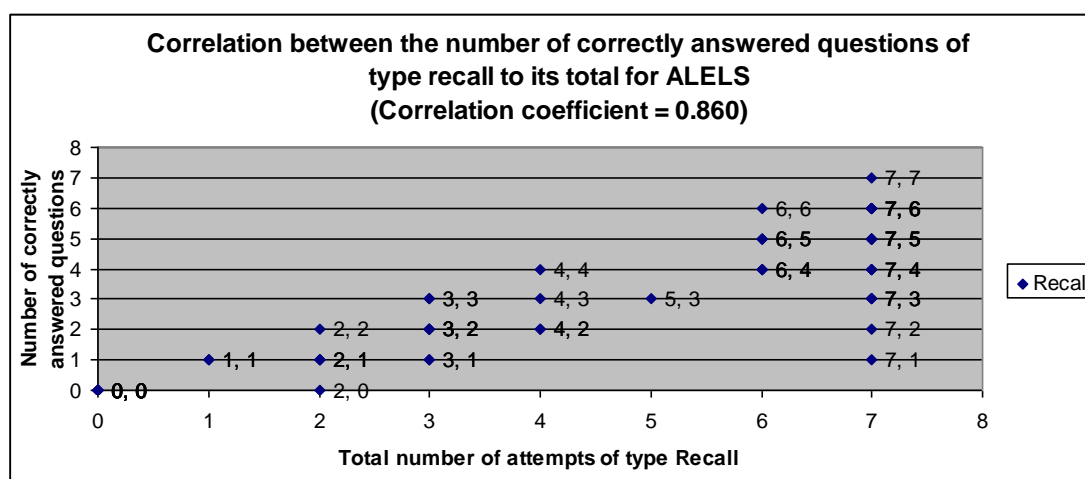
### **Analysis of learners' response based on the type of assessment questions and used ELSs**

In this section, the comparison of the correlation coefficient found from learners' activities on answering questions with their total number of correctly answered assessment questions are presented (data are from Table 22). Note that the correlation coefficient can be found in the formula below:

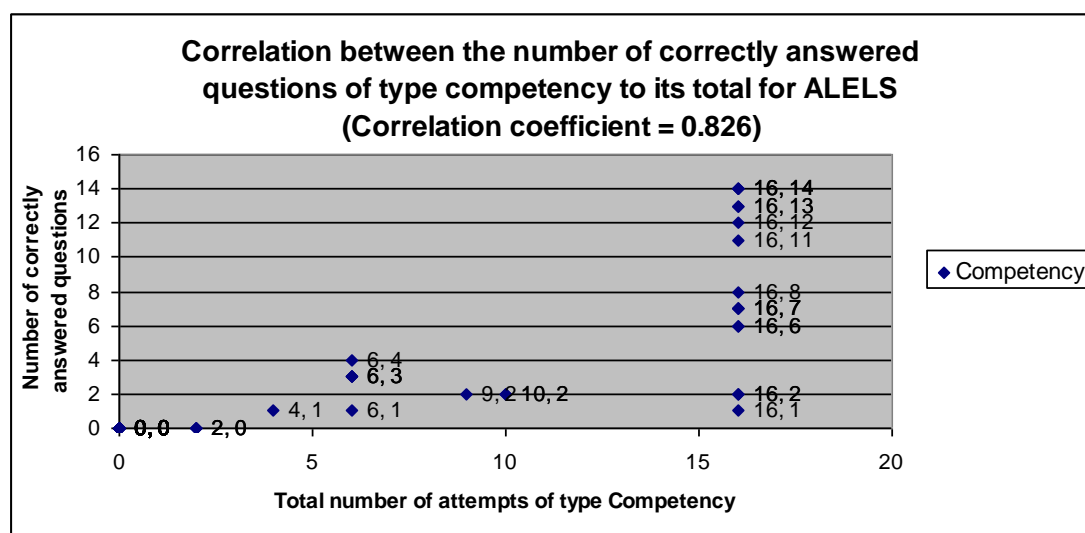
$$\text{correlation coefficient } r = \frac{\sum_{i=1}^n (X_i - \bar{X})(Y_i - \bar{Y})}{\sqrt{\sum_{i=1}^n (X_i - \bar{X})^2 \sum_{i=1}^n (Y_i - \bar{Y})^2}}$$

Where  $x$  and  $y$  are the sample means of the average data rows 1 and 2, where data row 1 or  $x$  in this example would be the “total number of attempts of different types of assessment questions (RCU)” and data row 2 or  $y$  is the “number of correctly answered questions”.

i) Learners' activities on answering assessment questions are presented in the figures below while using an adaptable e-learning system (A<sub>L</sub>ELS) (Figure 54, Figure 55 and Figure 56).



**Figure 54:** Chart on the comparison between ALELS learners' number of correctly answered questions with the total number of attempts on answering questions of type recall (R).



**Figure 55:** Chart on the comparison between ALELS learners' number of correctly answered questions with the total number of attempts on answering questions of type competency (C).

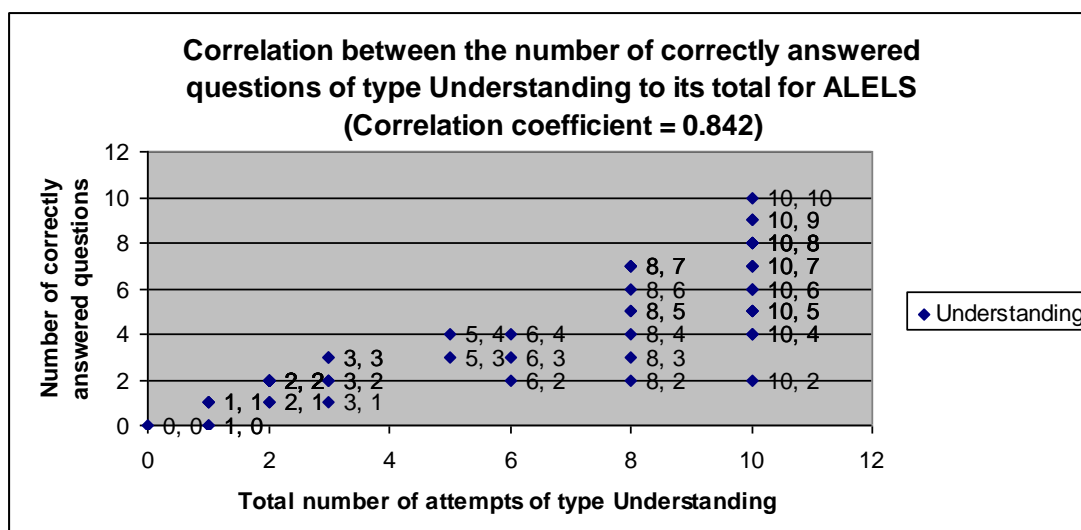


Figure 56: Chart on the comparison between ALELS learners' number of correctly answered questions with the total number of attempts on answering questions of type understanding (U).

ii) Learners' activities on answering assessment questions are presented in the figures below while using a personalised e-learning system (PELS) (Figure 57, Figure 58 and Figure 59).

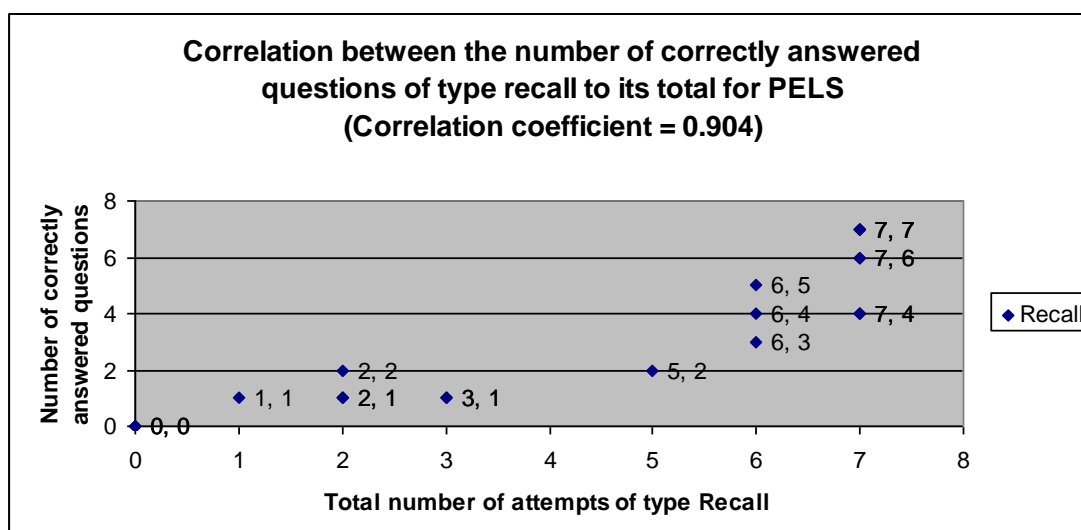
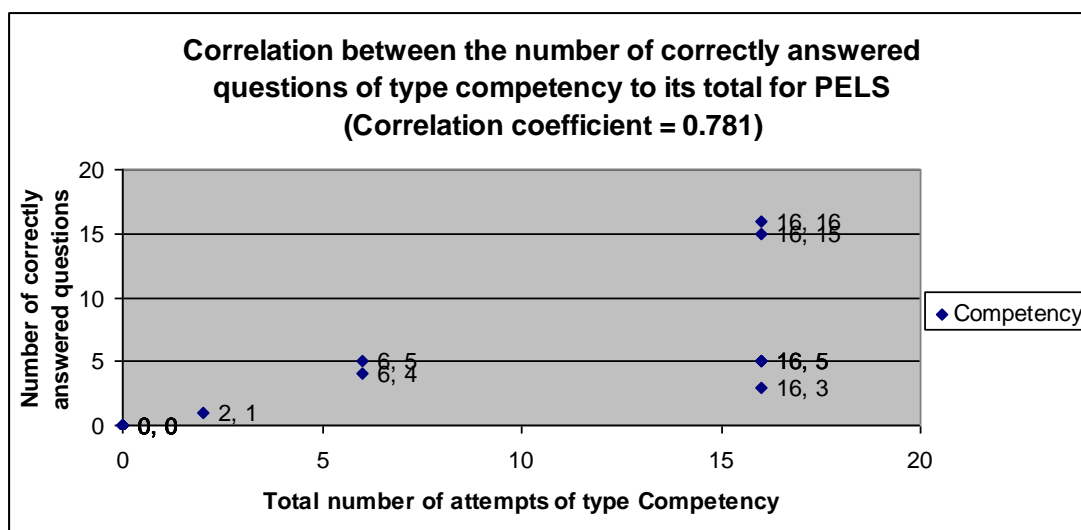
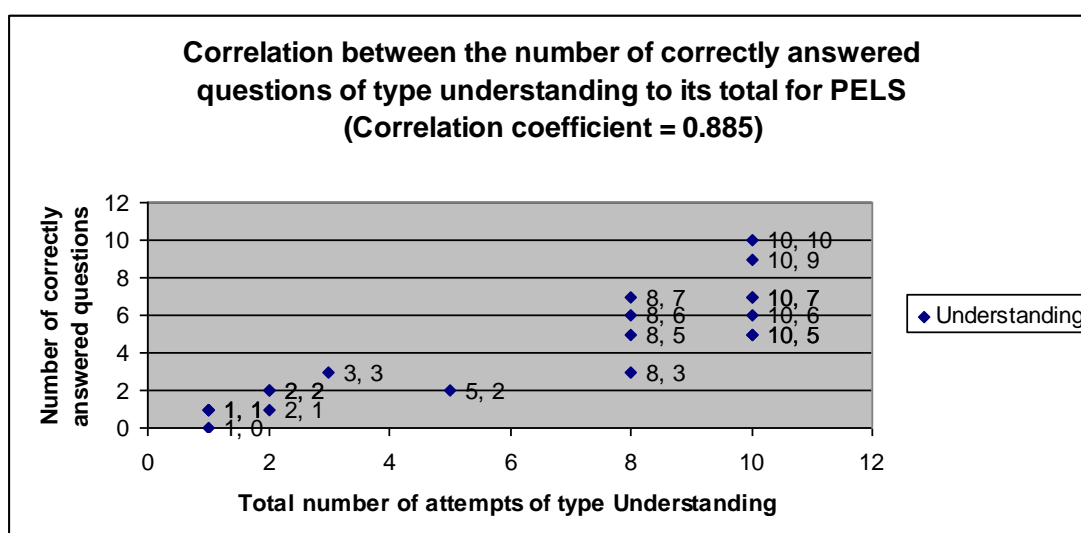


Figure 57: Chart on the comparison between PEELS learners' number of correctly answered questions with the total number of attempts on answering questions of type recall (R).



**Figure 58:** Chart on the comparison between PELS learners' number of correctly answered questions with the total number of attempts on answering questions of type competency (C).



**Figure 59:** Chart on the comparison between PELS learners' number of correctly answered questions with the total number of attempts on answering questions of type understanding (U).

The correlation coefficients found in Table 22 and the figures above (Figure 54 - Figure 59) are compared and analysed in Table 51 to present any indication of the increase in performance made by different types of assessment question with different types of e-learning system. This analysis would conclude another proof of hypothesis (sec 1.3) on the relationship between different types of e-learning system (adaptable

and personalised ELSs) and their compatible types of assessment question (R-recall, C-competency and U-understanding).

| Comparison between types of assessment question and their use in different ELSs |  |              |   |  |
|---|--|--------------|---|--|
| Type of assessment questions  | Type of E-learning System and its relevant correlation coefficient |              | Learners performed better using   | Comment  |
|   | Adaptable  | Personalised |   |  |
| Recall  | 0.860  | 0.904        | Personalised ELS<br>$9.05/0.860 = 1.05$<br>Or<br>$(1.05-1)/1.05*100 = 4.88\%$         | Indications of 4.88% better performance achieved by a recall type of assessment question with a personalised type of ELS         |
| Competency  | 0.826  | 0.781        | <u>Adaptable ELS</u><br>$0.826/0.781=1.06$<br>Or<br>$(1.06-1)/1.06*100 = 5.43\%$      | Indications of 5.43% better performance achieved by a competency type of assessment question with an adaptable type of ELS       |
| Understanding   | 0.842  | 0.885        | <u>Personalised ELS</u><br>$0.885/0.842 = 1.51$<br>Or<br>$(1.51-1)/1.51*100 = 4.89\%$ | Indications of 4.89% better performance achieved by an understanding type of assessment question with a personalised type of ELS |

**Table 51: Comparison of correlation coefficient between different types of assessment questions and their use in different types of ELSs.**

Table 51 indicates that (i) the use of personalised e-learning systems could support and increase learners' learning performance while using recall (with a correlation coefficient of 0.904 compared with 0.860 or 4.88%) and understanding (with a correlation coefficient of 0.885 compared with 0.842 or 4.89%) types of assessment questions, and (ii) the use of competency (with a correlation coefficient of 0.826 compared with 0.781 or 5.43%) types of e-learning system can increase their learning performance if adaptable ELS is used.

## **6.5 Conclusion**

To conclude this chapter it is vital to the discussion presented, to say that the quantity of samples in this investigation are the key to understanding the effectiveness of learners' learning preferences in different e-learning systems. Furthermore, the duration of the course is another factor to be considered when a learner learns a new topic or revises for it, so concepts of "prior burst", "midterm burst" and "prior-posterior burst" learning performance could be further investigated (Daniel & Virgilio 1998). However, this argument could not be made, since the duration of course was not sufficient and so the data gathered from learners' interaction with the system was not adequate to investigate the hypothesis in that term. Hence, another perspective was deemed necessary to examine the outcome of learners' activities in the learning environment so to evaluate the hypothesis given in section 2.8.

As we clearly see in the tables and diagrams above (Table 50, Table 51, and Figure 51 to Figure 59), they confirm the hypothesis presented at the beginning of this research (section 2.8), in which: "Analyses given above indicate that a learner's behaviour would be compatible with an environment where it has been set for him/her by the learning environment." This means that the concept of guided education makes an adequate conclusion that if learners have all the freedom to navigate through learning contents in a controlled learning environment, in the form of using personalised e-learning systems (PELS), the learning performance could be improved if only recall (R) and understanding (U) type of content materials are used (indication of 4.89% - average and rounded of 4.88% and 4.89%). But the use of a competency (C) type of content material would indicate an increase in performance if an adaptable e-learning system (A<sub>L</sub>ELS) is used (indication of 5.43%).

These conclusions show an interesting corollary to the type of learning environment created in the traditional face-to-face classrooms. In a traditional teaching classroom where pedagogical instruction is practiced, lecturer takes the learner through a predefined set of explanations for the purpose of teaching and as such during these sessions the teacher is in control and that would be the responsibility of learner to adapt to the learning environment. In terms of the delivery of types of knowledge (basic, procedural and conceptual knowledge), the lecturer uses different methods of instructions while teaching those topics. This is where lecturer aims at using pedagogical method to show learners how a topic can be understood based on three different types of knowledge. In lectures and tutorials, learners learn how to practice on “basic” and “conceptual” types of gained knowledge based on recall and understanding types of assessment questions, and in laboratory sessions, learners are given more control and learn how to practice their procedural knowledge to gain necessary competency on a topic. Hence, to reflect back on considering traditional learning style in terms of developing learning materials, experiential learning is the foundation stone of learning skills to raise the competency of a learner, which is what is shown here.

On the other hand, the relationship between the control given to either the learner or the system can be compared to a negotiation table, where if the control is given to the system, the learner expects to see an improvement in his/her learning performance, or when the control given to the learner for the selection of content materials based on their learning style, the system expects to be given direction on what to choose and how the selected content materials are to be delivered to the learner. This negotiation has already been practised in traditional classrooms. Learners by giving up on their freedom of the measure of learning control expect to see improvement in their newly



learnt knowledge and learning performance. On the other hand, the teacher also would expect to see an improvement on the method of selection of topics by learners and their gained knowledge when a measure of learning control is given to them. As said earlier, this type of negotiation takes place, explicitly or implicitly, every time a teaching session is in process.

## **Chapter 7 Conclusion and Future Work**

### **7.1 Overview**

To investigate the relationship between learners' learning performance based on i) their learning preferences, and ii) in different types of learning environment (adaptable and personalised e-learning systems), a revised hypothesis was developed (section 2.5.6) based on the survey done on UK's higher educational institutions, and by design and development of two above mentioned e-learning systems learners' activities were tracked down to seek any evidence exist in terms of proof or disproof of hypothesis. The data outcome was analysed and so forth the conclusion of this research is presented here. In short, this chapter is the concluding chapter in this research on theoretical discussions and applications of adaptability and personalisation of e-learning systems, which is given in the first section of this chapter. The second section presents a variety of ways of expanding this project into different areas involved with the educational philosophies, applied epistemology, design and development of e-learning systems and content material with the discussion on engineering of learning objects that have been presented.

### **7.2 Conclusion and Understanding of the outcome**

In the light of findings from the outcome of learners' activities there are indications, which provide evidence on having a relationship between the type of e-learning system they use as a means of gaining knowledge on a topic and their learning preferences. Since the type of learning environment provides different measures of

control to the learner depending on the type of instructional method the system has been based on, the learner can perform differently to the requirements of that learning environment. In order to consider the possibility of having content materials' effects on learners' performance, the dependency of assessment questions to the type of knowledge (basic, procedural, and conceptual types of knowledge – section 2.4) is used which in turn defines a learning environment.

To conclude this research the following factors which were associated with the investigation in hand and to observe that if there are any relationships between i) types of learners' learning preferences, ii) types of e-learning systems and iii) learners' learning performance. This discussion is in two main categories:

#### **A) Analysis of the data outcome from assessment based perspective**

Discussions about the types of assessment questions and their association to the learning environment while learners work on a series of topics to gain necessary knowledge, have shown interesting results, especially in terms of a given measure of control:

Types of e-learning systems presented a major role in this research with the consideration of types of learning assessment questions. Since it was decided (section 4.7) to have two types of e-learning systems named as adaptable and personalised e-learning systems ( $A_L$ ELS and PELS), types of control over content materials were clearly presented by different types of learners' interaction with learning materials, as results of their assessments explained in section 6.5. Three types of assessment questions – recall (R), competency (C) and understanding (U) – presented different outcome for learners' learning performance. The learners with access to adaptable e-learning system ( $A_L$ ELS) illustrated a better performance while interacting with competency (C) types of assessment questions, an indication of 5.43% - to be precise

0.826 compare to 0.781 in terms of correlation coefficient (Table 51). On the other hand learning performance of learners with access to personalised e-learning system (PELS) indicated an increase in their learning performance while interacting with recall (R) and understanding (U) types of e-learning system – an indication of 4.88% for recalling learnt materials – to be precise 0.904 compare to 0.860 in terms of relevant correlation coefficient; and an indication of 4.89% for understanding type of learnt materials – to be precise 0.885 compare to 0.842 in terms of relevant correlation coefficient.

With regards to the results and discussion above, it is imperative to mention that since the number of students engaged in the study was relatively low, especially when broken down into groups, although the statistics are indicative of a trend, these results tentatively suggest that trend. Hence the outcome indicates a relevancy between types of e-learning systems used with a measure of control given to learners. A measure of control over learning environment and its dependency to the type of learning materials (in terms of the type of assessment questions) indicated the relevancy of learners' learning performance to the type of e-learning system. Due to the nature of types of learning materials different measure of control is required to have an effect on learners' learning performance:

i) *Analysis of data on the relationship between the personalised e-learning system (PELS) and a measure of control given to learners:*

Based on the type of basic and conceptual knowledge, the type of assessment required to measure their effectiveness on learners' learning performance, which is a type of mental skill. The experiment confirms that learners can perform better in a personalised e-learning system.

ii) *Analysis of data on the relationship between the adaptable e-learning system (A<sub>L</sub>ELS) and a measure of control given to learners:*

For the competency type of assessment which is based on procedural type of knowledge, the motor skill does support the indication of increase in learners' learning performance while using an adaptable e-learning system.

### **B) Analysis of data outcome from learning philosophies perspective**

In this thesis, the effect of the personalisation of e-learning systems on individuals' learning performance was studied. The outcome of the analysis mentioned in section 6.3.3, which concludes discussions of: i) section 6.3.1 on data analysis and findings on learners' performance based on their learning preferences and VARK- & ARK-based content materials; and ii) section 6.3.2 on data analysis and finding on learners' performance based on types of e-learning systems (A<sub>L</sub>ELS and PELS); indicates that personalisation of e-learning systems gives a supportive and successful behaviouristic and constructivist effect on learner interaction with the learning environment (dependent on the type of learning content materials of recall, competency and understanding), supported by evidence obtained via assessments.

Whilst teachers in traditional classrooms (for example by providing different types of class activities) do their best to create a learning environment which give learners a sense of control over their learning, the pedagogical method of instruction cannot be ignored, which in turn means teacher control over learning materials. For independent learners, the measure of control is mitigated by the availability of learning resources, which have been produced by others, known as teachers or experts in the field. The greater the range of separately authored resources that are available in the system, the greater the level of control for the independent learner and the more heutagogic the learning environment.

Moreover, while they both share the concept and method of putting learners at the centre of the learning environment, the main difference exists in the method of preparation of content material. Content material is prepared by the lecturer of the subject via the andragogy method as opposed to the heutagogy method of transferring knowledge in which the learner should prepare that content material in the form of investigation on a new learning materials which supposedly be in his/her learning method. In that regard, different learning philosophies exist to support these methods, as discussed in section 2.2.1. Kirschner, P. A. et al. (2006) present an argument on the ineffectiveness of minimal guidance during instruction and how a constructivist, discovery approach, a problem-based method, or experiential and inquiry-based teachings would not be as effective as direct interaction between teacher and learner in the delivery of knowledge. In this regard the prior knowledge of a learner is most certainly an element on the effectiveness of heutagogical instructional design, however not as attainable as it should be for learners with basic or intermediate level of prior knowledge. As Kirschner discusses, whatever methods of transferring knowledge are used, a strong, clear and guided instructional method can be more productive in directing the learner than letting him/her to go through the flood of information to obtain the required knowledge by structuring his/her learning method. This understanding is more effective when the pedagogical approach puts learners' learning style under perspective while learning materials are under production, and also to show how effective a method of transferring knowledge can enhance the overall performance of the learning outcome of the learner.

Furthermore, evidence on Chapter 6 provides required support on the argument on the effectiveness of thorough study on the use of proper learning philosophy and methods of instructional designs. The behaviourism and constructivism approach form one side

and the planning for production of learning materials from different perspective based on pedagogical, andragogical and heutagogical views from the other side of the argument make a distinctive difference between our understandings on learner's learning performance; and also they are effective on learners' learning methods which if this effectiveness is based on learners' learning preferences. The understanding of the physiological learning categories of visual, auditory, reading and writing, and kinaesthetic and tactile learning preferences illustrates another approach on how a learner interacts with content materials and how this observation can be an element on increasing the effectiveness of the interaction between learners' and their learning performance. Additionally, the learning procedural or competency based material is enhanced by control given to learners and heutagogical instructional method be applied, recall and understanding type of learnt materials perform in a greater clarity of the outcome under andragogy, although some elements of pedagogy are still valuable.

### ***7.3 Contribution of Research***

This research set out to address the hypothesis, "That learners' learning performance increases more while interacting with adaptable e-learning systems than with personalised e-learning systems." This hypothesis has been proved in part, in that the research has demonstrated improved performance in Competency learning using the adaptable e-learning system, but the personalised e-learning system has proved more successful in Recall and Understanding learning (section 6.5). It can be argued that this reflects a clear correlation with existing classroom-based teaching, where students are given greater control over their learning in lab-based teaching, where competency learning will generally take place, as opposed to lecture and tutorial situations where

the tutor remains firmly in control, and recall and understanding learning is paramount.

With regard to the contributions made by this research, firstly the work in designing and building an e-learning content selection system, based on learner preferences, is novel in that no such system existed when this research began. The consideration of the impact of learner control on the learning process, in particular in relation to Andragogic and Heutagogic principles, is also novel, and represents the first attempt to establish a relationship between e-learning content, according to type, and the measure of learner control within the e-learning system. The fact that a significant body of data exists from the investigation in this research, will also be of benefit to the research community. Finally, the combination of these outcomes can form the basis of a design model for future e-learning systems, where content selection according to user preference and differential levels of learner control, relative to content type, can be applied to generate more effective learning.

## **7.4 Further Work**

### **7.4.1 Overview**

In this section, areas of applicable to further study have been discussed, in addition to other possible fields, which could expand this research further.

### **7.4.2 Areas of applicable to further study**

During this investigation, there were many elements involved on design and development of a learning management system. How an information system could be used for the purpose of delivery of knowledge. How an online learning environment could support such activity. How varieties of concepts were investigated to



understand core parts of a learning object and how those concepts and findings were applied to the design and development of an adaptable personalised e-learning system. The above statements are a few ideas which were investigated throughout this thesis and the outcome was the A<sub>L</sub>PELS. However, this is just the beginning of a long journey in the field of instructional design, and future studies could be done to expand this study. To ease the discussion following areas could be further investigated:

### **Learning Object:**

Understanding and learning more about the size and properties involved with this structure could be further expanded. As day by day researchers are continuously investigating a variety of standards on determining a better structure for its concept.

### **Different types of ELSs**

This section could be expanded by further study on involving other variables from different types of learning preferences; such as Kolb and Mayers-Briggs type indicators' tests. It is correct that the personalisation of any e-learning system would require involving all available factors based on individual personalities learning preferences, and it could expand the number of possibilities to an unknown number, but there has to be some point to start learning about what those variables share and how those number of variables could come together and shared values.

### **Database**

Existing design could be upgraded to a better version to cover more tracking activities for future research. This new version could include a better user interface for updating metadata to the system; so for example “instructional designers” could go through a wizard for that purpose.

### **Web application**

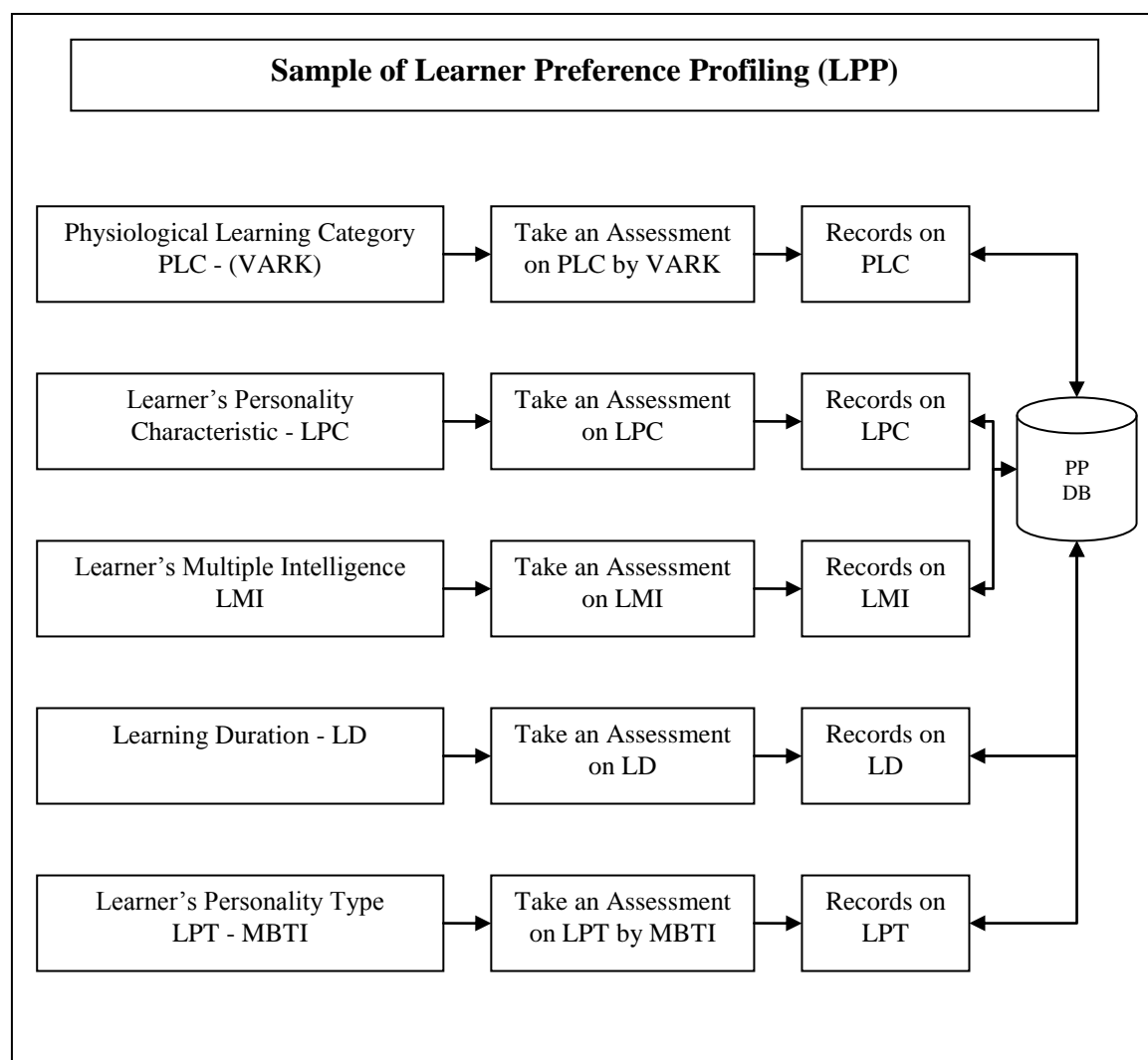
Different technology could be used such as AJAX to ease the process of tracking activities. On the other hand, because the environment is known by now, a better design could be sketched for the system.

### **Other proposals**

In this respect many proposals could be made towards the design and development of a new field of further research, however, there are two other main areas which could expand this study way further and they are:

- Studying the effect of each type of ELS on different stages of study in K12 and higher education.
- Learner Preference Profiling (LPP), which would discuss further addition to learner's list of e-learning systems variables.

The following diagram (Figure 60) presents an idea on learner-preference-profiling mechanism for the purpose of finding the best possible approach on the selection of learning objects. The outcome of the data would be stored on LHDB (the database of learner's history of activities)(section 4.6 - Figure 15) and be used as sets of instantiation values for the varieties of e-learning systems studied on chapter Chapter 3.



**Figure 60: A proposed sketch for a Lerner Preference Profiling (LPP)**

- Although, this will be the main element in designing the next version of APELS for sharing information with other peers and lecturers as list of references to other external resources or from his/her points of views.
- On the other hand with the advancements of social networking technologies, it sounds feasible to further the research in this term to investigate the effectiveness of collaborational e-learning systems.

### **7.4.3 Latest research**

The interested reader is advised to check online resources on e-learning systems and latest researches from the University's eCentre website at:

<http://ecentre.cms.gre.ac.uk/index.php>

This is in addition to the added resources on the list of "References" section of the thesis.

## References

### **ADL-SCORM (2004)**

Advanced Distributed Learning – SCORM, 2001. The Sharable Content Object Reference Model (SCORM). Last viewed on 10<sup>th</sup> December 2010 from:  
<http://www.adlnet.gov/technologies/scorm/default.aspx>

### **Alavi, M. and Leidner D. (2001)**

Alavi, M. and D.E. Leidner [2001] "Review: Knowledge Management and knowledge management systems: Conceptual foundations and research issue," MIS Quarterly, vol. 25 Issue 1, pp. 107-136.

### **Aldrige, J. (2002)**

Aldrige, J. 2002. Knowledge on demand: An application of software agents and e-learning, KOD project – IST – 1999 – 12503), FD Learning Ltd.

### **Alkhalidi, F.M., & Olaimat, M. (2006)**

Alkhalidi, F.M., & Olaimat, M. (2006). Knowledge Conversion and Transfer: A Mathematical Interpretation. Interdisciplinary Journal of Information, Knowledge, and Management, 1, 137-149. Available at:  
<http://ijikm.org/Volume1/IJIKMv1p137-149Alkhalidi.pdf> (last viewed on 11/04/2009).

### **Answers-Benard Convection Law, (2007)**

Answers.com, 2007. Adapted from:  
<http://www.answers.com/%22Benard%20Convection%20Law%22>, Last viewed on: 02 Feb 2007. hybridization

### **Answers-Hybridization, (2007)**

Answers.com, 2007. Adapted from: <http://www.answers.com/topic/hybridization>, Last viewed on: 02 Feb 2007.

### **Answers-Magnetization, (2007)**

Answers.com, 2007. Adapted from: <http://www.answers.com/topic/spontaneous-magnetization>, Last viewed on: 02 Feb 2007.

### **Aranda, N., (2007)**

Natalie Aranda, 2007. A Brief History of E-learning and Distance Education. March 20, 2007. last viewed online on: 14th July 2008, at:  
<http://ezinearticles.com/?A-Brief-History-of-E-learning-and-Distance-Education&id=496460>

### **Arney, Don (2005)**

Don Arney (2005). <http://faculty.ivytech7.cc.in.us/darney> , (Last viewed: 15/08/2006)

**Atherton, J. S. (2005)**

ATHERTON J S (2005) Learning and Teaching: Behaviourism [On-line] UK: Available: <http://www.learningandteaching.info/learning/behaviour.htm>  
Accessed: 9 July 2008

**Authoring Zone (2007)**

Authoring Zone. Learning Object Characteristics. Retrieved from <http://www.loaz.com/learning-objects/learning-object-characteristics.html> on 10 May 2007]

**Baker 1991**

Baker, M. J. 1991. The influence of dialogue processes on the generation of students' collaborative explanations for simple physical phenomena. In Proceedings of the International Conference on the Learning Sciences. Illinois, USA August 1991. 9 - 19.

**Berg, D. (2009)**

Don Berg, (2009). Definition of Education. Reterived 25<sup>th</sup> July 2010, from <http://www.teach-kids-attitude-1st.com/definition-of-education.html>

**Barnett, J. (2002 and 2004)**

John Barnett, (2002 and 2004). Science Education & Online Education. Reterived Febraury 18th 2007, from <http://publish.edu.uwo.ca/john.barnett/faculty/classnotes.html>

**Baumard, P. (1999)**

Baumard, P. (1999). Tacit knowledge in organizations. London, Thousand Oaks, New Delhi: Sage.

**Bligh, DA. 1972**

Bligh DA: What objectives can lectures achieve: In *What's the Use of Lectures?* Baltimore: Penguin Books Inc., 1972, pp 17-50.

**Bloom, B. S. (1971)**

B. S. Bloom 1971. Learning for mastery. In J. H. Block (Ed.). *Mastery learning: theory and practice*. New York: Holt, Rinehart & Winston. In: Hueyching Janice Jih, (1996). The impact of learners' pathways on learning performance in multimedia Computer Aided Learning. *Journal of Network and Computer Applications* (1996) 19, 367-380. Last viewed on: 10/07/2008 at: <http://www.sciencedirect.com>

**Bonwell, CC. at. el. 1991**

Bonwell CC, Eison JA: The modified lecture. In *Active Learning: Creating Excitement in the Classroom*. ASHE-Eric Higher Education Report, No. 1.

Washington, DC: George Washington University, School of Education and Human Development, 1991, pp 7-19.

**Boot, R., & Hodgson, V. (1987)**

Boot, R., & Hodgson, V. (1987). Open learning: Meaning and experience. In Hodgson, V., Mann, S., & Snell, R. (Eds) *Beyond distance teaching – towards open learning*, UK: Open University Press, 5-15.

**Boyle (2003)**

Boyle, T. (2003). Design principles for authoring dynamic, reusable learning objects. *Australian Journal of Educational Technology*, 19(1), 46-58

**Brown, Collins, & Duguid (1988)**

John Seely Brown, Allan Collins and Paul Duguid, 1988. Situated cognition and the culture of learning. Technical report, Institute for Research on Learning. Educational Researcher; v18 n1, pp. 32-42, Jan-Feb 1989. Last viewed at:

<http://www.exploratorium.edu/ifi/resources/museumeducation/situated.html>, on: 03 October 2009.

**Brusilovsky P. , Ritter S. and Schwarz E. (1997)**

Brusilovsky P. , Ritter S. and Schwarz E. (1997). Distributed intelligent tutoring on the web. In B. De Boulay and R. Mizoguchi (ed) *Artificial Intelligence in Education*. Amsterdam : IOS Press

**Burns H. L. and Capps C. G. (1988)**

Burns H. L. and Capps C. G. (1988). Foundations of intelligent tutoring systems: An introduction. In M. Polson and J. Richardson (ed) *Intelligent Tutoring Systems: An Introduction*. Hillsdale: Lawrence Erlbaum Associated Publication

**Bush, V. (1946)**

Vannevar Bush. 1946. As we may think. *The Atlantic Monthly*, July 1946. Last viewed on: 14th July 2008 at: <http://www.theatlantic.com/doc/194507/bush>

**Cancore (2004)**

Cancore 2.0 Guidelines to LOM and best practices guide, April 2004: <http://www.cancore.ca/en/guidelines.html>

**Carroll, J. B. (1963)**

Carroll, J. B. (1963). "A model of school learning", *Teachers College Record*, 64, 723-733.

**CETL**

*CETL Reusable Learning Objects*, Available online: <http://www.rlo-cetl.ac.uk/faqs.htm>, Last accessed: 16 May 2007

**Chi et al. (1989)**

Chi, M. T. H.; Bassok, M.; Lewis, M. W.; Reinman, P.; and Glaser, R. 1989. Self-explanations: how students study and use examples in learning to solve problems. *Cognitive Science* 13:259 – 294.

**Chianga, C.K., Chapmanb, H., Elderc, R. (2010)**

Ching-Kuei Chianga, Helen Chapmanb, Ruth Elderc. 2010. Changing to learner-centred education: Challenges experienced by nurse educators in Taiwan. *Nurse education today*. Volume 30, Issue 8, Pages 816-820.

**Chism et al. (1990)**

Chism N, Jones C, Macce B, Mountford R., 1990. Lecturing. In *Teaching at The Ohio State University: A Handbook*. Columbus: Ohio State University, Center for Teaching Excellence, 1990, pp 29-41.

**Choo, C. W. (1998)**

Choo, C. W. (1998). *The knowing organisation*. Oxford University Press. ISBN: 0195176782.

**Coppola, N., Hiltz, S., & Rotter, N. (2002)**

Coppola, N., Hiltz, S., & Rotter, N. (2002). Becoming a virtual professor: pedagogical roles and asynchronous learning networks. *Journal of Management Information Systems*, 18 (4), 169-189.

**Christoph et al. (1998)**

Christoph, R. T., Schoenfield, G. A., & Tansky, J. W. (1998). Overcoming barriers to training and utilizing technology: the influence of self-efficacy factors on multimedia-based training receptiveness. *Human Resource Development Quarterly*, 9, 25–38. In: Michael Workman, 2004. Performance and perceived effectiveness in computer-based and computer-aided education: do cognitive styles make a difference? *Computers in Human Behavior* 20 (2004) 517–534.

**Costin, F., 1972**

Costin, F., 1972: Lecturing versus other methods of teaching: a review of research. *British Jour of Educational Technology* 3:4-31, 1972.

**Dabbagh N. (1999)**

Dabbagh N., 1999. Gestalt and Instructional Design. Clare Torrans. EDIT 704. Last retrieved: 4/4/2007. Web resource:  
<http://chd.gmu.edu/immersion/knowledgebase/strategies/cognitivism/gestalt/gestalt.htm>

**Daniel & Virgilio (1998)**

Daniel A. & Virgilio A.F. (1998) Capacity Planning for Web Performance: Metrics, Models, and Methods. Prentice-Hall International (UK) Limited, London. Adapted from: Wu-Yuin Hwang, Chin-Yu Wang (2004). A study of learning time patterns in asynchronous learning environments. Blackwell Publishing Ltd 2004. *Journal of Computer Assisted Learning* 20 (4), pp292–304. doi:10.1111/j.1365-2729.2004.00088.x



**Devaney L. (2010)**

Laura Devaney, 2010. Digital access, collaboration a must for students. Last retrieved from: 25<sup>th</sup> July 2010. Published online on 16<sup>th</sup> May 2010, from:  
<http://www.eschoolnews.com/2010/03/16/digital-access-collaboration-a-must-for-students/>

**Diamond and Jefferies (2006)**

Ian Diamond and Jolie Jefferies, 2006. *Beginning Statistics, An introduction for Social Scientists*. Sage publication. ISBN: 0-7619-6061-9. P. 192.

**Dick, W. and Carey, L. (1990)**

Dick, W. and Carey, L. 1990. *The Systematic Design of Instruction*, New York: Harper Colins. Adopted from: David E. Stone and Constance L. Koskinen, 2002. *Planning and Design for High-Tech Web-based Training*, 2002 Artech House. ISBN: 1-58053-315-9.

**Dillenbourg et al.1994**

Dillenbourg, P.; Baker, M. Blaye, A.; and O'Malley, C. 1994. *The Evolution of Reserch on Collaborative Learning*. <http://tecfa.unige.ch/tecfa-research/lhm/ESF-Chap5.text>

**Dix et al. (1998)**

Alan Dix, Janet Finlay, Gregory Abowd and Russell Beale. 1998. *Human-Computer Interaction*. Second Edition. Person Education Limited. ISBN 0-13-239864-8.

**DLNET (2003)**

DLNET (2003), **Learning Object Definition**, last retrieved: 21 April 2007, [http://www.dlnet.vt.edu/Resources/reports/ARI\\_LO\\_Def.pdf](http://www.dlnet.vt.edu/Resources/reports/ARI_LO_Def.pdf)

**Doise 1990**

Doise, W.1990. *The development of individual competencies through social interaction. Children helping Children*. J. Wiley and Sons. 43 – 64.

**Downes,.S (2005)**

Downes,.S (2005). *Connective knowledge*. Retrieved: April 3 2007 from.  
<http://www.downes.ca/cgi-bin/page.cgi?post=33034> ]

**Duch, B. J., Groh S. E., & Allen, D. E. ( 2001)**

Duch, B. J., Groh S. E., & Allen, D. E., 2001 *The power of problem-based learning*. Sterling, VA: Stylus Publishing, Inc. 2001.

Edwards, F. (1989). *What is humanism?* Amherst, NY: American Humanist Association. Available online: <http://www.jcn.com/humanism.html>

**Dunn, R. & Dunn, K., (1992)**

Dunn, R. and Dunn, K., (1992). *Teaching Elementary Students Through Their Individual Learning Styles*. Boston: Allyn and Bacon.

**Dunn, R. & Dunn, K., (1993)**

Dunn, R. and Dunn, K., (1993). *Teaching Secondary Students Through Their Individual Learning Styles*. Boston: Allyn and Bacon.

**Eisenstadt, M., & Vincent, T. (2000)**

Eisenstadt, M., & Vincent, T. (2000). *The knowledge web: Learning and collaborating on the Net*, UK: Kogan Page.

**ELISA (2005)**

ELISA (eLearning Independent Study Skills Awards), 2005.  
<http://elisa.gre.ac.uk/reports.html>, Last viewed on: 15/12/2005.

**Elsom-Cook, M., (2001)**

Mark Elsom-Cook, 2001. *Principles of Interactive Multimedia*. Mc-Graw Hill. ISBN 007-709610-x. P.121-155

**Encyclopedia, (2007)**

Encyclopedia, 2007. Adapted from: <http://www.encyclopedia.com/doc/1E1-thermody.html>, Last viewed on: 4/4/2007.

**Erren et al. 2007**

Thomas C. Erren, Paul Cullen, Michael Erren. *Neanderthal, Chimp and Human Genomes: Hypotheses wanted for research into brain evolution*. Medical Hypothesis. 2007. Article in Press. Available online 24 July 2007.

**Facebook (2004)**

Facebook (2004) Social Network Service. Last viewed on 11/05/2009 at:  
<http://www.facebook.com>

**Favorin, M. (1995)**

Favorin, M. (1995) Towards computer support for collaborative learning at work: Six requirements. In: Victor Kaptelinin, Michael Cole (1997). "Individual and Collective Activities in Educational Computer Game Playing." Last viewed on 10/07/2008 at:  
<http://lhc.ucsd.edu/People/MCole/Activities.html>

**Felder & Brent 1996**

Felder R. M. & Brent R. (1996) *Capacity Planning for Web Performance: Metrics, Models, and Methods*. Prentice-Hall International (UK) Limited, London.

**Fidishun, D. (2000)**

Fidishun , Dolores, (2000). *Andragogy and Technology: Integrating Adult Learning Theory As We Teach With Technology*. Penn State Great Valley School of Graduate Professional Studies

**Fischer et al. (2002)**

Fischer, K. M., Savenye, W. C., & Sullivan, H. J. (2002). Formative evaluation of computer-based training for a university financial system. *Performance Improvement Quarterly*, 15, 11–23. In: Michael Workman, 2004. *Performance and perceived effectiveness in computer-based and computer-aided education: do cognitive styles make a difference?* *Computers in Human Behavior* 20 (2004) 517–534.

**Fleming, N.D. (2006)**

Neil D. Fleming (2006). Copyright Version 7.0 held by Neil D. Fleming, Christchurch, New Zealand and Charles C. Bonwell, Green Mountain Falls, Colorado 80819 U.S.A. Last viewed online on 26 August 2008 at: <http://www.vark-learn.com/english/index.asp>

**Fleming, N.D. & Mills, C. (1992)**

Fleming, N.D. & Mills, C. (1992). Not another inventory, rather a catalyst for reflection To improve the academy, (11), 137-149. In: <http://www.ntlf.com/html/lib/suppmat/74vark2.htm>

**Gardner 1993**

Gardner H. 1993. *Multiple Intelligences: The Theory in Practice*.

**Garrison, R. (2000)**

Garrison, R. (2000). Theoretical challenges for distance education in the 21<sup>st</sup> Century: A shift from structural to transactional issues. *International Review of Research in Open and distance Learning*, 1 (1), <http://www.icaap.org/iuicode?149.1.1.2>

**Ghorai, S., (2003)**

Ghorai, S. 2003. Rayleigh-Benard Convection. Adpated from: <http://home.iitk.ac.in/~sghorai/NOTES/benard/node1.html>, Last viewed on: 02 Feb 2007.

**Ginger, J. (2008)**

Jeff Ginger, (2008). The Facebook Project: Fostering Multidisciplinary e-Social Science. *LIS590: Distributed Knowledge, Bruce & Haythornthwaite, Revision 1, 10.03.2008*. Adapted from: <http://www.facebookproject.com/research/jeff/publications/esocialscience.html> Last viewed: 11/05/2009.

**Glatzeder, B.M. et al. (2010)**

B.M. Glatzeder et al. (eds.), 2010. Towards a Theory of Thinking, On Thinking. A Gestalt Perspective on the Psychology of Thinking, page 49. DOI 10.1007/978-3-642-03129-8\_4, (c) Springer-Verlag Berlin Heidelberg 2010.

**Grant R.M. (2008)**

Robert M. Grant, Contemporary Strategy Analysis, Sixth Edition, 2008, Blackwell publishing, pp. 159-165.

**Haberberg, A. & Rieple, A., 2008**

Adrian Haberberg & Alison Rieple. 2008. Strategic Management, Theory and Application. Oxford University Press. ISBN 978-0-19-921646-8.

**Hase, S. (2009)**

Hase, Stewart, 2009. Heutagogy and e-learning in the workplace: some challenges and opportunities. Impact: Journal of applied research in workplace e-learning, v. 1, no. 1, 2009. pp.43-52. Bondi Junction, N.S.W.: E-learning Network of Australasia, 2009. This document may be found on the Impact website at: <http://journal.ernet.com.au/index.php/impact/article/view/13/11> (viewed April 2011).

**Hase, S. & Kenyon, C. (2000)**

Stewart Hase & Chris Kenyon, (Dec 2000). “From Andragogy to Heutagogy.” Melbourne, Australia: ultiBASE. Peer Reviewed. Original ultiBASE publication. Adapted from: <http://ultibase.rmit.edu.au//Articles/dec00/hase2.htm>, Last viewed on 10/07/2008, and 28/04/2009.

**Herman, J. (2002)**

Jim Herman, 2002. **Study Tools for Different Learning Styles - How to Respond to the Struggling Student. Style-Specific Advice - Based upon Kolb & Felder.** A Seminar Presentation - November 5, 2002. Last viewed online on 14<sup>th</sup> July 2008 at: <http://www.lamsquare.com/document/perstype.pdf> . Original work has been done by: R. Craig Hogan and David W. Champagne, 1979. Personal Style Inventory, Strengths and Weaknesses of the Types.

**HERO (2008)**

HERO (Higher Education and Research Opportunities in the UK). Last viewed online: 08/08/2008 <http://www.hero.ac.uk>

**Heylighen, F. (2003)**

Heylighen, Francis, 2003. “The Science of Self-organization and Adaptivity”, in: Knowledge Management, Organizational Intelligence and Learning, and Complexity, in: The Encyclopedia of Life Support Systems (Eolss Publishers, Oxford). Last viewed on 14<sup>th</sup> July 2008 at: <http://pespmc1.vub.ac.be/papers/EOLSS-Self-Organiz.pdf>

**Hi5 (2003)**

Hi5 (2003). Social Network Service. Last viewed on 11/05/2009 at: <http://www.hi5.com>

**Hiemstra, R., & Sisco, B. (1990)**

Hiemstra, R., & Sisco, B. (1990). Moving from Pedagogy to Andragogy. Adapted from Hiemstra, R., & Sisco, B. (1990). *Individualizing instruction: Making learning personal, empowering, and successful*. San Francisco: Jossey-Bass. Last viewed: 27/04/2009 at: <http://www-distance.syr.edu/andraggy.html> and <http://www-distance.syr.edu/distancenew.html>

**Hill, L.F. (1991)**

Hill, Lloydene F. (1991). Pedagogical and Andragogical Learning. *AuthorsDen.com online booking publisher*. The article could be accessed at: <http://www.authorsden.com/visit/viewArticle.asp?id=1416> Last viewed on: 26/04/2009.

**History Of VLEs (2009).**

Wikipedia.org, 2009. History of Virtual Learning Environments. From: [http://en.wikipedia.org/wiki/History\\_of\\_virtual\\_learning\\_environments](http://en.wikipedia.org/wiki/History_of_virtual_learning_environments). Last viewed: 01/06/2009.

**Hodgins, W. (2004a).**

Hodgins, W. 2004. Into the future of learning objects. Paper presented at the *Partnership in Global Learning Conference*, June 3, 2004, Orlando, FL.

**Hodgins, W. (2004b).**

Hodgins, W. 2004. The future of learning objects. *Proceedings of the ECI Conference on e-Technologies in Engineering Education: Learning Outcomes Providing Future Possibilities*. Retrieved April 14, 2005 from: <http://services.bepress.com/eci/etechnologies/11>

**Hoobveld et al. (2001)**

Hoobveld, A. W. M., Paas, F., Jochems, W. M. G., & van Merriënboer, J. J. G. (2001). The effects of a web-based training in an instructional systems design approach on teachers' instructional design behavior. *Computers in Human Behavior*, 17, 363–371. In: Michael Workman, 2004. Performance and perceived effectiveness in computer-based and computer-aided education: do cognitive styles make a difference? *Computers in Human Behavior* 20 (2004) 517–534.

**Horton W., 2000**

Horton W., *Designing Web-based Training*, Wiley 2000.

**Horton, W. (2001)**

William Horton. "Leading E-Learning" 2001. ASTD (American Society for Training and Development). Page 4. ISBN:1562862987. Last viewed online on "14th July 2008" at: [http://books.google.com/books?id=PPJsx18AAQMC&pg=PA4&lpg=PA4&dq=%22history+of+e-learning%22&source=web&ots=cy-5bSmof2&sig=8uhlaka4OLCepkZ738U4Y8ilzQw&hl=en&sa=X&oi=book\\_result&resnum=20&ct=result](http://books.google.com/books?id=PPJsx18AAQMC&pg=PA4&lpg=PA4&dq=%22history+of+e-learning%22&source=web&ots=cy-5bSmof2&sig=8uhlaka4OLCepkZ738U4Y8ilzQw&hl=en&sa=X&oi=book_result&resnum=20&ct=result)

**Huitt, W. (2001)**

Huitt, W. (2001). Humanism and open education. Educational Psychology Interactive. Valdosta, GA: Valdosta State University. Retrieved [date], from <http://chiron.valdosta.edu/whuitt/col/affsys/humed.html>

**Hurley et al. (2005)**

Tracy A. Hurley, Carolyn W. Green, Texas A&M University-Kingsville, San Antonio. 2005. Knowledge Management And The Nonprofit Industry: A Within And Between Approach. Journal of Knowledge Management Practice, January 2005. Last viewed on 01/07/2008 at: <http://www.tlinc.com/articl79.htm>

**Hwang & Wang (2004)**

Wu-Yuin Hwang, Chin-Yu Wang (2004). A study of learning time patterns in asynchronous learning environments. Blackwell Publishing Ltd 2004. Journal of Computer Assisted Learning 20 (4), pp292–304. doi:10.1111/j.1365-2729.2004.00088.x

**Idrus, R. (2000)**

Idrus, R. (2000). The pedagogical issues in e-learning. *New straits times/management times*, August 28, 2000.

**IEEE LTSC (2002)**

IEEE Learning Technology Standards Committee (2002). *IEEE Standard for Learning Object Metadata (IEEE LOM). IEEE Standard 1484.12.1*, Institute of Electrical and Electronics Engineers, New York, 2002. Available online: <http://ltsc.ieee.org/wg12/par1484-12-1.html> Last viewed: 14 May 2007.

**Intelligent Tutor, (2004)**

Intelligent Tutor, 2009. From: <http://www.intelligent-tutor.com/>, last viewed on: 31/03/2004

**InstructionalDesign, (2009)**

InstructionalDesign, (2009). From: <http://www.instructionaldesign.org/>, last viewed on: 05/05/2009

**Islam, K. (2002)**

Islam, K. (2002). Is e-learning floundering? *e-learning*, May, 22-26.

**Jeffries, W.B., Huggett, K.N. (2010)**

W.B. Jeffries, K.N. Huggett (eds.), *An Introduction to Medical Teaching*, DOI 10.1007/978-90-481-3641-4\_4, (C) Springer Science+Business Media B.V. 2010.

**Johnson et al., (1992)**

Johnson DW, Johnson RG, Smith KA: College teaching and cooperative learning. In *Active Learning: Cooperation in the College Classroom*. Edina, MN: Interaction Book Co., 1992, pp 1:1-1:27.

**Jonassen et al. 1997**

Jonassen, D. H, Dyer, D., Peters, K., Robinson, T., Harvey, D., King, M., & Loughner, P. (1997). Cognitive flexibility hypertexts on the Web: Engaging learners in meaning making. In Khan, B. H. (Ed.) *Web-based instruction*, New Jersey: Educational Technology Publications, 119-133.

**Jones R. (2006)**

Jones R. (2006), Designing Adaptable Learning Resources with Learning Object Patterns. Texas Digital Library. [ Available online at: Last accessed: 02 April 2007]

**Kapp, Alexander (1833)**

Kapp, Alexander (1833): Platon's Erziehungslehre, als Pädagogik für die Einzelnen und als Staatspädagogik. Minden und Leipzig. The origin of the document is conformed and the resources has been adapted from: <http://www.uni-bamberg.de/fileadmin/andragogik/08/andragogik/andragogy/index.htm>, last viewed on: 28/04/2009.

**Ketamo, H. (2003)**

Ketamo, H. (2003) An Adaptive Geometry Game For Handheld Devices. *Educational Techology & Society*, 6 (1)ISSN 1436-4522

**Khun, T. (1962)**

Khun, T. (1962). *The structure of scientific revolutions*, Chicago: Chicago University Press.

**Kinshuk & Russell (2002)**

Kinshuk, Patel, A., & Russell, D. (2002). Intelligent and Adaptive Systems. In H. H. Adelsberger, B. Collins & J. M. Pawlowski (Eds.) *Handbook on Information Technologies for Education and Training*, Germany: Springer-Verlag, 79-92.

**Kirschner, P. A., & Paas, F. (2001)**

Kirschner, P. A., & Paas, F. (2001). Web-enhanced higher education: a tower of Babel. *Computers in Human Behavior*, 17, 347–353. In: Michael Workman, 2004. Performance and perceived effectiveness in computer-based and computer-aided education: do cognitive styles make a difference? *Computers in Human Behavior* 20 (2004) 517–534.

**Kirschner, P. A. et al. (2006)**

Kirschner, P. A., Sweller, J. And clark, R. E. (2006). Why Minimal Guidance During Instruction Does Not Work: An Analysis of the Failure of Constructivist, Discovery, Problem-Based, Experiential, and Inquiry-Based Teaching. *EDUCATIONAL PSYCHOLOGIST*, 41(2), 75–86. Last viewed on 11<sup>th</sup> December 2010 at: [http://www.cogtech.usc.edu/publications/kirschner\\_Sweller\\_Clark.pdf](http://www.cogtech.usc.edu/publications/kirschner_Sweller_Clark.pdf)

**Knapper D. J., Cropley A. J., (1985)**

Knapper DJ, Cropley A. J., 1985: Lifelong learning and institutions of higher education. In *Lifelong Learning and Higher Education*. London: Croom Helm, 1985, pp 62-87.

**Knowledge. (2009)**

Knowledge. (2009). In Merriam-Webster Online Dictionary. Retrieved May 27, 2009, from <http://www.merriam-webster.com/dictionary/knowledge>.

**Knowles, M. S. (1968)**

Knowles, M. S. (1968). Andragogy, not pedagogy! *Adult Leadership*, 16,350-352,386.

**Knowles, M. S. (1975)**

Knowles, M. S. (1975). *Self-directed learning*. New York: Association Press.

**Knowles, M. S. (1980)**

Knowles, M. S. (1980). *The modern practice of adult education (revised and updated)*. Chicago: Association Press (originally published in 1970).

**Knowles, M. (1984)**

Knowles, M. (1984). *The adult learner: A neglected species*. Houston: Gulf Publishing.

**Knowles, M., & Associates. (1984)**

Knowles, M., & Associates. (1984). *Andragogy in Action. Applying modern principles of adult education*. San Francisco: Jossey Bass.

**Knowles, M., Holton, E., & Swanson, R. (1998)**

Knowles, M., Holton, E., & Swanson, R. (1998). *The adult learner: The definitive classic in adult education and human resource development (5th ed.)*. Houston, TX: Gulf Publishing Co.

**Kohli, W. (1995)**

Kohli, W. (1995). *Critical conversations in philosophy of education*. Tourtledge, NY: Miller Publishing. In: Michael Workman, 2004. Performance and perceived effectiveness in computer-based and computer-aided education: do cognitive styles make a difference? *Computers in Human Behavior* 20 (2004) 517–534.

**Kumar, V. S. (1996)**

Vivekanandan Suresh Kumar, (1996). *Theories of Learning and Cognition in Collaboration*. Reterived February 18<sup>th</sup> 2007, from <http://www.cs.usask.ca/grads/vsk719/academic/890/project2/node7.html>

**Kumar V., (2002)**

Vivekanandan Suresh Kumar, 2002. *Computer-Supported Collaborative Learning Issues for Research*. <http://www.sfu.ca/~vivek/personal/papers/CSCLIssuesForReserchRevised.pdf>

**Lam, S. (2008)**

Steve Y. W. Lam, 2008. *Blended E-learning Model for Geomatics Curriculum: Design, implementation and Evaluation*. *Sharing Good Practices: E-learning*



in Surveying, Geo-information Sciences and Land Administration. FIG International Workshop 2008. Enschede, The Netherlands, 11-13 June 2008.

**Laudon, and Laudon (2007)**

Laudon, Kenneth C. and Laudon, Jane P., 2007. Management Information Systems, Managing The Digital Firm. Tenth Edition. Person-Prentic Hall. ISBN: 0-13-230461-9, p. 434.

**Laurillard, D. (2002)**

Laurillard, D. (2002). Design tools for eLearning. *Keynote address at the 19<sup>th</sup> Annual Conference of the Australasian Society for Computers in Learning in Tertiary Education (ASCILITE)*, December 6-8, 2002, Auckland, New Zealand.

**LCPP (1997)**

LCPP (1997). Learner-Centered Psychological Principles: A Framework for School Redesign and Reform Revision prepared by a Work Group of the American Psychological Association's Board of Educational Affairs (BEA), November 1997. Also available at: <http://www.apa.org/ed/cpse/LCPP.pdf> and <http://www.apa.org/ed/lcp2/lcp14.html>

**Lee, L.L. and Zailani, S. (2010)**

Lim Lay Lee and Suhaiza Zailani, 2010. Validating the measures for intention to enroll an online MBA program. *International Business Management* 4(3): 124-133, 2010. ISSN: 1993-5250. (c) Medwell Journals, 2010. Last viewed on 10th April 2011 at: <http://docsdrive.com/pdfs/medwelljournals/ibm/2010/124-133.pdf>

**LeJeune, N. F. (1998)**

Noel F. LeJeune. 1998. University of Colorado at Denver, Learner-Centered Strategies in Web-Based Instruction for Adults. Last viewed on 10/07/2008 at: <http://spu.autoupdate.com/ler.php?modulo=18&texto=1632>

**Leontiev, A. N., (1978)**

Leontiev, A. N. (1978) *Activity. Consciousness. Personality*. Englewood Cliffs, NJ: Prentice Hall 1978.

**Lindquist J. (1978)**

Lindquist J., 1978. "Starting up: educational and organizational health at the strategies institutions. In *Strategies for Change*." Berkeley: Pacific Soundings Press, 1978, pp 31-52.

**LOC, Learning Object Characteristics (2007)**

Learning Object Authoring Zone. Learning Object Characteristics. Available online: <http://www.loaz.com/learning-objects/learning-object-characteristics.html>, Last viewed: 10 May 2007]

**Locatis & Weisberg 1997**

Locatis C. & Weisberg m. (1997) Distributed learning and the Internet. Contemporary Education 68, 100 – 103.

**Lofman, B. (2002)**

Brian Lofman, Complex Adaptive Pedagogy for Transforming Student Learning: Education Business Students for the New World Disorder, Abstract for Managing The Complex: IV Conference. Institute for the Study of Coherence and Emergence. Fort Myers, FL, 2002. Last viewed online on 09<sup>th</sup> July 2008 at: [http://isce.edu/ISCE\\_Group\\_Site/web-content/ISCE\\_Events/Naples\\_2002/Naples\\_2002\\_Papers/Lofman.pdf](http://isce.edu/ISCE_Group_Site/web-content/ISCE_Events/Naples_2002/Naples_2002_Papers/Lofman.pdf)

**Madden & Slavin 1983**

Madden, N. E., and Slavin, R. E. 1983. Cooperative learning and social acceptance of mainstreamed academically handicapped students. Journal of special education 17:171 – 182.

**Mark Nichols**, *A theory for e-learning*, [see: **Nichols, M. (2003)**]

**Mason, R. (1989)**

Mason, R. (1989). An evaluation of CoSy on an Open University course. In Mason, R., & Kaye, A. (Eds.) *Mindweave: Communication, Computers and Distance Education*, Oxford: Pergamon Press, <http://icdl.open.ac.uk/lit2k/external.ihtml?loc=http://icdl.open.ac.uk/literaturestore/mindweave/mindweave.html>.

**Matzler K. et al. (2008)**

Kurt Matzler, Birgit Renzl, Julia Muller, Stephan Herting, Todd A. Mooradian. Personality traits and knowledge sharing. Journal of Economic Psychology 29 (2008) 301-313. {K. Matzler et al. / Journal of Economic Psychology 29 (2008) 301-313}

**MBTI, 2009**

Myers-Briggs Type Indicator, 2009. Last viewed at: <http://www.myersbriggs.org/my-mbti-personality-type/mbti-basics/>, on 03 October 2009.

**McCalla (1990)**

McCalla, G. 1990. The central importance of student modelling to intelligent tutoring. Technical report, ARIES Laboratory, Department of Computational Science, University of Saskatchewan, Saskatoon, Saskatchewan S7N 0W0 Canada.

**McCarry, N.E. and Mazur, J.M. (2008)**

Nancy E. McCrary, Joan M. Mazur. 2008. Conceptualizing a narrative simulation to promote dialogic reflection: using a multiple outcome design to engage teacher mentors. Education Tech Research Dev. DOI 10.1007/s11423-

008-9100-y. Association for Educational Communications and Technology, 2008. Last viewed on 10th April 2011 at:  
<http://www.springerlink.com/content/k82m25771821461/>

**Mead, G. H. (1932/1977)**

Mead, G. H. (1932/1977) On social psychology. Selected papers. Edited by A. Strauss. Chicago: The University of Chicago Press.

**Meehan, J. (1999)**

Meehan, J. (1999): Knowledge Management: A Case of Quelling Rebellion? Critical Management Studies Conference UMIST. Adapted from: Jouni Meriluoto of the NOKIA Research Center. Knowledge Management and Information Systems – Finding a Sociotechnical Golden Mean. Key note presentation for ROCKET Workshop in ICE 2003. Last viewed online on 09/07/2008 at: [http://rocket.vub.ac.be/KM\\_IS\\_ROCKET.pdf](http://rocket.vub.ac.be/KM_IS_ROCKET.pdf)

**Menges R. J. 1994**

Menges R. J. (1994), *Teaching in the age of electronic information. In Teaching Tips: Strategies, Research, and Theory for College and University Teachers, 9<sup>th</sup> edn ed W. J. McKeachie, pp. 183 – 193. D. C. Heath, Lexington, MA.*

**Meriluoto, J. (2003)**

Jouni Meriluoto, 2003. Knowledge Management and Information Systems – Finding a Sociotechnical Golden Mean. Key note presentation for ROCKET Workshop in ICE 2003. From NOKIA Research Center. Last viewed online on 09/07/2008 at: [http://rocket.vub.ac.be/KM\\_IS\\_ROCKET.pdf](http://rocket.vub.ac.be/KM_IS_ROCKET.pdf)

**Mimi (2007)**

Hybridization, 2007. The definition is adapted from:  
<http://en.mimi.hu/gardening/hybridization.html>, last viewed on: 02 Feb 2007.

**Mioduser et al., 1999**

Mioduser, D., Nachmias, R., Oren, A. & Lahav, O. (1999). Web-based learning environments (WBLES): current implementation and evolving trends. *Journal of Network and Computer Application*, 22, 233-247.

**Monadjemi, A. and Ahmadi, A. 2002**

Monadjemi A, Ahmadi A., 2002. *How will Computer Aided Learning Develop.*

**Moore et al., 1994**

Moore, Joyce L.; Lin, Xiaodong; Schwartz, Daniel L.; Petrosino, Anthony; Hickey, Daniel T.; Campbell, Olin; and Hmelo, Cindy. The Relationship Between Situated Cognition and Anchored Instruction: A Response to Tripp. *Educational Technology*, October, 1994.

**Moore et al. 1995**

Moore M. G. and Kearsley G., *Distance Education: A Systems View*. Boston: Wadsworth Publishing, 1995.

**Morgan G., (2008)**

Greg Morgan, 2008. IT Service Centre, Information Services Maintainer. University of Melbourne. Retrieved from: <http://www.infodiv.unimelb.edu.au/knowledgebase/itservices/a-z/k.html>, Date the document created: 12 Oct 2006, Last modified: 25 March 2008. Last viewed: 27th May 2009.

**Mustafa, A. 2004**

Mustafa, A., Unpublished in-house seminar presentation. V3-PhD-Student-Seminar-31-03-2004-Adaptive e-Learning System.ppt

**Mustafa et al. 2005**

Mustafa, A., Dastbaz, M., Stoneham, R.J., 2005. Analysis and Design of PELS (Personalised E-Learning Systems). Reports and Presentations. JISC – The Joint Information Systems Committee. Last viewed on: 18<sup>th</sup> July 2008 at: <http://elisa.gre.ac.uk/reports.html>

**MySpace (2003)**

MySpace, 2003. A Social Network Service. Last viewed on: 11/05/2009 at:

**Nelson, R. R., &Winter, S. G. (1982)**

Nelson, R. R., &Winter, S. G., 1982. An evolutionary theory of economic change. Cambridge, Mass. u.a: Belknap Press of Harvard University Press

**Nickols, F. W. (2000)**

The knowledge in knowledge management. In Cortada, J.W. & Woods, J.A. (Eds) The knowledge management yearbook 2000-2001 (pp. 12-21). Boston, MA: Butterworth-Heinmann. Last viewed online on 27/06/2008 at: [http://home.att.net/~nickols/Knowledge\\_in\\_KM.htm](http://home.att.net/~nickols/Knowledge_in_KM.htm)

**Nichols, M., (2001)**

Nichols, M. (2001). *Teaching for learning*, Palmerston North: TrainInc.co.nz.

**Nichols, M. (2003)**

Nichols, M. (2003). A theory for eLearning. *Educational Technology & Society*, 6(2), 1-10, (ISSN 1436-4522). Last viewed on 14<sup>th</sup> July 2008 at: [http://www.ifets.info/journals/6\\_2/1.html](http://www.ifets.info/journals/6_2/1.html)

**Nipper, S. (1989)**

Nipper, S. (1989). Third generation distance learning and computer conferencing. In Mason, R., & Kaye, A. (Eds.) *Mindweave*, Oxford: Pergamon Press, 63-73.

**Nonaka, I. (1991)**

Nonaka, Ikujiro. The Knowledge Creating Company. Harvard Business Review, November-December 1991.

**Nonaka, I. (1993)**

Nonaka, I. (1993). *On a knowledge creating organisation*. Paper presented at AIF national congress, POSMA, October 1993]

**Nonaka, I., & Takeuchi, H. (1995)**

Nonaka, I., & Takeuchi, H. (1995). The knowledge-creating company – How Japanese companies create the dynamics of innovation. New York/Oxford: Oxford University Press, p. 62.

**Nonaka et al. (1996)**

Ikujiro Nonaka, Katsubiro Umemoto and Dai Senoo. From Information Processing to Knowledge Creation: A Paradigm Shift in Business Management. *Technology in Society*, Vol. 18, No. 2, pp. 203-218, 1996. Published by Elsevier Science Ltd

**O'Brien & Marakas (1999)**

O'Brien, James A. and Marakas, Geroge M. (2008). *Management Information Systems*. McGraw-Hill/Irwin. ISBN: 978-0-07-351154-2, p. 62.

**Oliver, R. (1999)**

Oliver, R. (1999). Exploring strategies for online teaching and learning. *Distance Education*, 20 (2), 240-254.

**Pajares (2002)**

Pajares (2002). Overview of social cognitive theory and of self-efficacy. Retrieved: April 4, 2007 from <http://www.emory.edu/EDUCATION/mfp/eff.html>

**Parise P. 1998**

Parise P., 1998. *Information Power Goes Online: Teaching Information Literacy to distance learners*. 1998. LOEX-of-the-West conference

**Pavlov, I. P. (1899)**

Pavlov, Ivan Petrovich (1899). Laws of conditioned reflex. Last viewed online on 09/07/2008 at: <http://www.britannica.com/nobelprize/article-5559> and as a published thesis by Wolfson, in 1899. *Natural Conditioned Reflexes*. Published thesis entitled *Observations upon Salivary Secretion*. Last viewed as a confirmed comment on 09/07/2008 at: [http://www.ivanpavlov.com/lectures/ivan\\_pavlov-bibliography.htm](http://www.ivanpavlov.com/lectures/ivan_pavlov-bibliography.htm)

**Peters, O. (2000)**

Peters, O. (2000). Digital learning environments: New possibilities and opportunities. *International Review of Research in Open and Distance Learning*, 1 (1), <http://www.icaap.org/iuicode?149.1.1.7>

**Polanyi, M. (1962)**

Michael Polanyi. Tacit Knowing: Its Bearing on Some Problems of Philosophy. *Reviews of Modern Physics*, 34 (4). Oct. 1962, 601-616. Last viewed online on 27/06/2008 at:

<http://www.culturaleconomics.atfreeweb.com/Anno/Polanyi%20Tacit%20Knowlmg%20RMP%201962.htm>

**Polanyi, M. (1966)**

Michael Polanyi. *The tacit dimension*. London, UK: Routledge and Kegan Paul. 1966.

**PowerPoint, (2002)**

Microsoft Office PowerPoint, 2002. A presentation software developed by Microsoft, version 2002. From <http://office.microsoft.com/en-us/downloads/CD010225001033.aspx>. Last viewed on: 01/06/2009.

**Ramachandran, K.M. & Tsokos, C.P. (2009)**

Kandethody M. Ramachandran & Chris P. Tsokos, 2009. *Mathematical Statistics with Applications*. Elsevier Academic Press. 1<sup>st</sup> edition. ISBN: 978-0-12-374848-5. p.17 & p.510-522

**Raman M. et al. (2005)**

Murali Raman, Terry Ryan, Lome Olfman, (2005). *Journal of Information Systems Education*. Last viewed online on 01/07/2008 at: [http://findarticles.com/p/articles/mi\\_qa4041/is\\_200510/ai\\_n15715725/print](http://findarticles.com/p/articles/mi_qa4041/is_200510/ai_n15715725/print) ).

**Ramsden, P. (1992)**

Ramsden, P. (1992). *Learning to teach in higher education*, London: Routledge.

**Ravenscroft, A. (2001)**

Ravenscroft, A. (2001). Designing E-learning Interactions in the 21st Century: revisiting and rethinking the role of theory. *European Journal of Education*, 36 (2), 133-156.

**Recker, M. M., Dorward, J., and Nelson, L.M. (2004)**

Recker, M. M., Dorward, J., and Nelson, L.M. (2004). Discovery and Use of Online Learning Resources: Case Study Findings. *Educational Technology & Society*, 7 (2), 93-104.]

**Reeves, T. (2002)**

Reeves, T. (2002). Storm clouds on the digital education horizon. In Williamson, A., Gunn, C., Young, A., & Clear, T. (Eds.) *Keynote address at the 19<sup>th</sup> Annual Conference of the Australasian Society for Computers in Learning in Tertiary Education (ASCILITE)*, December 6-8, 2002, Auckland, New Zealand.

**Rehak and Mason (2003)**

Rehak, D. R., Mason, R. Keeping the learning in learning objects, in Littlejohn, A. (Ed.) *Reusing online resources: a sustainable approach to e-Learning*. Kogan Page, London, 2003. (pp.22-30)

**Reischmann, Jost (2000)**

Reischmann, Jost (2000): Welcome to ANDRAGOGY.net. At: <http://www.andragogy.net>. Version Feb. 23, 2000. Last viewed on 28/04/2009

**Reischmann, Jost (2004)**

Reischmann, Jost (2004): Andragogy. History, Meaning, Context, Function. At: <http://www.andragogy.net>. Version Sept. 9, 2004. Last viewed on 28/04/2009

**Retails, S., & Skordalakis, E., 2001**

Retails, S., & Skordalakis, E., 2001. CADMOS: an approach to developing web-based instructional systems. *Computers in Human Behaviour*, 17, 393-407.

**Reusable Learning (2007)**

Retrieved from: Reusable Learning:Granularity. Retrieved from <http://www.reusablelearning.org/index.asp?id=28> Last viewed: on 5 September 2007. In: Learning Object Characteristics (2007).

**Rogers, C. R (1969)**

Rogers, C. R (1969). Freedom To Learn, Ohio: Merrill

**Salmon, G. (2000)**

Salmon, G. (2000). *E-moderating: The key to teaching and learning online*, London: Kogan Page.

**Sandholtz et al. 1997**

Sanholtz J. H., Ringstaff C. & Dwyer D. C. (1997) Teaching with Technology: Creating Student-Centred Classrooms. Teachers College Press, New York.

**Shabani J. (2003)**

Shabani J. (2003). Modern Methods of Teaching and Learning in Higher Education. Retrieved: April 4, 2007. <http://www.viheaf.net/module2/VIHEAF-Mod2Wk1-Lesson2.htm>, <http://www.viheaf.net/> and <http://www.nucvihep.net/>.

**Shana Z.A. (2009)**

Zuhrieh A. Shana (2009). A pilot study to investigate the effectiveness of multimedia CD-ROM vis-à-vis traditional printed based technology in teaching forth-grade children. *International Journal. On E-Learning* (2009) 8(3), 403-423.

**Shute, Valerie and Towle (2003)**

Shute, Valerie and Towle (2003). 'Adaptive E-Learning', *Educational Psychologist*, 38: 2, 105-114. Retrieved: 08 June 2010. URL: [http://dx.doi.org/10.1207/S15326985EP3802\\_5](http://dx.doi.org/10.1207/S15326985EP3802_5)

**Sicilia at el. (2004).**

Miguel-Ángel Sicilia, Elena García (2004). Describing Learning Object Types in Ontological Structures: Towards Specialized Pedagogical Selection.

[**Ref:** Miguel-Ángel Sicilia, Elena García (2004), Describing Learning Object Types in Ontological Structures: Towards Specialized Pedagogical Selection. Computer Science Department, Polytechnic School, University of Alcalá, Madrid, Spain, [msicilia@uah.es](mailto:msicilia@uah.es) , [elena.garciab@uah.es](mailto:elena.garciab@uah.es) , Salvador Sánchez-Alonso, Computer Languages and Systems Department, Pontifical University of Salamanca (Madrid campus), Spain, [salvador.sanchez@upsam.net](mailto:salvador.sanchez@upsam.net) , Elena Rodríguez, Open University of Catalonia, Spain [mrodriguezgo@uoc.net](mailto:mrodriguezgo@uoc.net) ]

**Siemens, G. (2005)**

Siemens, George. 2005. Connectivism, A Learning Theory for the Digital Age. Last updated: April 5 2005. (original paper published on: December 12, 2004) Retrieved: 02/04/2007 from: <http://www.elearnspace.org/Articles/connectivism.htm> and [http://www.tdl.org/Journal/Jan\\_05/article01.htm](http://www.tdl.org/Journal/Jan_05/article01.htm)

**Siemens, G. (2006)**

Siemens, George. 2006. Knowing Knowledge. ISBN 978-1-4303-0230-8. Available to download at: <http://www.knowingknowledge.com/book.php> . Retrieved: 02/04/2007

**Skinner, B. F. (1938)**

Burrhus Frederic Skinner (1938). The Behavior of Organisms: An Experimental Analysis.

**Somerville, M.J. (2010)**

Margaret J. Somerville, 2010. A Place Pedagogy for 'Global Contemporaneity'. Educational Philosophy and Theory. volume 42,issue 3, pages 326-344, April 2010.

**Slavin 1978**

Slavin, R. E. 1978. Student teams and achievement divisions. Journal of Research and Development in Education 12:39 - 49.

**StatSoft, 2008**

StatSoft (2008). Description: This is a website which presents basic statistical facts, samples and formulae for its readers. Last viewed on 27<sup>th</sup> August 2008 at: <http://www.statsoft.com/textbook/stbasic.html>

**StatSoft (2010)**

Electronic Version): StatSoft, Inc. (2010). Electronic Statistics Textbook. Tulsa, OK: StatSoft. WEB: <http://www.statsoft.com/textbook/>. Last viewed on 15<sup>th</sup> Feb 2011 at: <http://www.statsoft.com/textbook/elementary-concepts-in-statistics/>  
(Printed Version): Hill, T. & Lewicki, P. (2007). STATISTICS Methods and Applications. StatSoft, Tulsa, OK.

**Stone, D. E. and Koskinen, C. L. (2002)**



David E. Stone and Constance L. Koskinen, 2002. *Planning and Design for High-Tech Web-based Training*, 2002 Artech House. ISBN: 1-58053-315-9.

**Stuart J, Rutherford RJD, 1978**

Stuart J, Rutherford RJD: Medical student concentration during lectures. *Lancet* 2:514-516, 1978.

**Svensson, L., Nilsson, S. & Svanberg, P. (2010)**

Svensson, L., Nilsson, S. & Svanberg, P. (2010) Learning Models in Online Education: On the transformation from tutors to producers. In Z. Abas et al. (Eds.), *Proceedings of Global Learn Asia Pacific 2010* (pp. 3707-3712). AACE.

**Swan, K. (2001)**

Swan, K. (2001). Virtual interaction: Design factors affecting student satisfaction and perceived learning in asynchronous online courses. *Distance Education*, 22 (2), 306-331.

**Tam, M. (2000)**

Tam, M. (2000). Constructivism, instructional design, and technology: Implications for transforming distance learning. *Educational Technology & Society*, 3 (2), 50-60.

**Taylor, C. R., (2002)**

Taylor, C.R., 2002. E-learning: The second wave. *ASTD's Online Magazine*. October 21, 2002. Last accessed: April 5, 2007. Accessed from: <http://www.learningcircuits.org/2002/oct2002/taylor.html>

**Teasley, S. D., Roschelle, J. (1993)**

Teasley, S. D., Roschelle, J. (1993) Constructing a joint problem space: The computer as a tool for sharing knowledge. In: Victor Kaptelinin, Michael Cole (1997). *“Individual and Collective Activities in Educational Computer Game Playing.”* Last viewed on 10/07/2008 at: <http://lhc.ucsd.edu/People/MCole/Activities.html>

**The Free Dictionary (2007)**

The Free Dictionary, 2007. Adapted from <http://encyclopedia.thefreedictionary.com/crystallisation>, last visited: 02 Feb 2007.

**Thompson K., Yonekura F. (2005)**

Thompson K., Yonekura F., 2005. Practical Guidelines for Learning Object Granularity from One Higher Education Setting. *Interdisciplinary Journal of Knowledge and Learning Objects* Volume 1, 2005. Available online at: <http://ijklo.org/Volume1/v1p163-179Thompson.pdf>, last viewed: 10 May 2007

**Thorpe, M. (2002)**

Thorpe, M. (2002). Rethinking learner support: The challenge of collaborative online learning. *Open Learning*, 17 (2), 105-119.

**Torkazadeh, G. J., & Van Dyke, T. P. (2002)**

Torkazadeh, G. J., & Van Dyke, T. P. (2002). Effects of training on internet self-efficacy and computer attitudes. *Computers in Human Behaviour*, 18, 479-494.

**Tseng, S. (2008)**

Shu-Mei Tseng, 2008. The effects of information technology on knowledge management systems. *Expert Systems with Applications* 35 (2008) 150–160

**Twitter (2006)**

Twitter (2006). Social Network Service. Last viewed on 11/05/2009 at: <http://www.twitter.com>

**Victor Kaptelinin, Michael Cole (1997).**

Victor Kaptelinin, Michael Cole (1997). “*Individual and Collective Activities in Educational Computer Game Playing.*” Last viewed on 10/07/2008 at: <http://lhc.ucsd.edu/People/MCole/Activities.html>

**Vita, A.D. (2007)**

Adriano De Vita. 2007. A Grass-Root History of e-Learning. These slides was produced for the Meeting: Vocational entrepreneurship training in Slovenia, Italy and EU State of the art and future needs September 26 – 28, 2007 ECIPA S.c.a.r.l. - 30175 Marghera (VE) - Via della Pila 3/B <http://www.ecipaveneto.it/>. Viewed online on 14th July 2008, at: <http://www.slideshare.net/adriano/1-grass-root-history> from original webiste at: <http://www.weblearning.it/>

**Vu, K.L. (2011)**

Kim-Phuong L. Vu, 2011. Unintentional and intentional learning of noncorresponding stimulus-response associations in the Simon task. *Acta Psychologica*. Volume 136, Issue 2, February 2011, Pages 217-2

**Vygotsky, L. (1934/1994)**

Vygotsky, L. (1934/1994) The development of academic concepts in school aged children. Teoksessa R. van der Veer & J. Valsiner (Eds.). *The Vygotsky reader* (355-370). Oxford: Blackwell. (Originally published in Russian 1934)

**Vygotsky, L.S. 1978**

Lev S. Vygotsky, (1978) *Mind in Society: The Development of Higher Psychological Processes*. Cambridge, MA: Haroard University Press.

**Wagner, E. D., & McCombs, B. L. (1995).**

Wagner, E. D., & McCombs, B. L. (1995). Learner-centered psychological principles in practice: Designs for distance education. *Educational Technology*, 32(2), 32-35. adopted from Noel F. LeJeune. University of Colorado at Denver, Learner-Centered Strategies in Web-Based Instruction for Adults. Last viewed on 10/07/2008 at: <http://spu.autoupdate.com/ler.php?modulo=18&texto=1632>

**Watson, D. (2001)**

Watson, D. (2001). Pedagogy before technology: Re-thinking the relationship between ICT and teaching. *Education and Information Technologies*, 6 (4), 251-266.

**Weiss, R. E., Knowlton, D. S., & Morrison, G. R. (2002)**

Weiss, R. E., Knowlton, D. S., & Morrison, G. R. (2002). Principles for using animation in computerbased instruction: theoretical heuristics for effective design. *Computers in Human Behavior*, 18, 465–477. In: Michael Workman, 2004. Performance and perceived effectiveness in computer-based and computer-aided education: do cognitive styles make a difference? *Computers in Human Behavior* 20 (2004) 517–534.

**Weller, M. (2002)**

Weller, M. (2002). *Delivering learning on the Net*, UK: Kogan Page.

**Wentling et al. (2000)**

Wentling, T. L., Waight, C., Strazzo, D., File, J., La Fleur, J. & Kanfer, A. *The Future of e-Learning: A Corporate and an Academic Perspective*. The Knowledge & Learning Systems Group. Retrieved January 12, 2008.

**Wiley, D. A. (2000)**

Wiley, D. A. (2000). *Learning object design and sequencing theory*. Unpublished PhD dissertation, Brigham young University. Available: <http://davidwiley.com/papers/dissertation/dissertation.pdf>

**Wiley, D. A. (2000b)**

Wiley, D. A., 2000. “Connecting learning objects to instructional design theory: A definition, a metaphor, and a taxonomy”. In Wiley, D. A. (Ed.), *The Instructional Use of Learning Objects: Online Version*. Retrieved June 07, 2004 from <http://reusability.org/read/chapters/wiley.doc>

**Wolf et al. 1998**

Wolf C., Crider L. Mayer L. McBride M. & Sherman R. (1998) *Toward a Miami University model for Internet intensive higher education. Journal on Excellence in College Teaching* 9, 29 – 51.

**Workman, M. (2004)**

Workman, M. (2004). Performance and perceived effectiveness in computer-based and computer-aided education: Do cognitive styles make a difference? [Electronic Version]. *Computers in Human Behavior*, 20, 517-534. Retrieved July 15<sup>th</sup>, 2008 from <http://www.sciencedirect.com/>

## Appendices

|                     |  |      |
|---------------------|--|------|
| Appendix 1          | Proposed Forms of e-learning Systems under study.....  | 1-1  |
| <b>Appendix 1-1</b> | <b>ELS (E-Learning System)</b> .....   | 1-1  |
| <b>Appendix 1-2</b> | <b>PELS (Personalised E-Learning System)</b> .....   | 1-3  |
| <b>Appendix 1-3</b> | <b>A<sub>L</sub>ELS (Adaptable E-Learning System)</b> .....  | 1-5  |
| <b>Appendix 1-4</b> | <b>A<sub>V</sub>ELS (Adaptive E-Learning System)</b> .....   | 1-7  |
| <b>Appendix 1-5</b> | <b>A<sub>L</sub>PELS (Adaptable Personalised E-Learning System)</b> .....                                | 1-10 |
| <b>Appendix 1-6</b> | <b>A<sub>V</sub>PELS (Adaptive Personalised E-Learning System)</b> .....                                 | 1-10 |
| <b>Appendix 1-7</b> | <b>AAELS (A<sub>V</sub>A<sub>L</sub>ELS) (Adaptive Adaptable E-Learning System)</b> ..                   | 1-12 |
| <b>Appendix 1-8</b> | <b>AAPELS (A<sub>V</sub>A<sub>L</sub>PELS) (Adaptive Adaptable Personalised E-Learning System)</b> ..... | 1-14 |
| <b>Appendix 1-9</b> | <b>Concluding Remarks [Needs revising]</b> .....   | 1-16 |
| Appendix 2          | Creating a template on developing COs.....   | 2-1  |
| Appendix 3          | Types and Methods of creating Digital Assets .....   | 3-1  |
| Appendix 4          | System of Contents Provider .....  | 4-1  |
| Appendix 5          | Getting ARK based DAs out of VARK based DAs concept .....  | 5-1  |
| Appendix 6          | Draft Proposal of user interface while learner navigating through contents materials .....               | 6-1  |
| Appendix 7          | Content material presenter and activity tracking system.....   | 7-1  |
| Appendix 8          | Existing Adaptive systems in Nature.....   | 8-1  |
| Appendix 9          | Knowledge, Knowledge Management and Knowledge Transferring Systems                                       | 9-1  |
| Appendix 10         | Investigation of Existing ELS types .....  | 10-1 |
| Appendix 11         | First Conference Paper – AACE ED Media 2006 .....  | 11-1 |
| Appendix 12         | Second conference paper AACE E-Learn 2006.....   | 12-1 |
| Appendix 13         | Data stored on UK’s Educational institutions.....  | 13-1 |
| Appendix 14         | Methods of Instructional Designs .....   | 14-1 |
| Appendix 15         | Instructional Design Models in Different Philosophies.....   | 15-1 |
| Appendix 16         | Learning Duration (Length of Learning, Learning Time Pattern) .....                                      | 16-1 |
| Appendix 17         | Learning Object.....   | 17-1 |
| Appendix 18         | Set of roles on designing a collaborative learning environment.....                                      | 18-1 |

## Appendix 1 Proposed Forms of e-learning Systems under study

Further to investigation on types of e-learning systems, following presents other 7 types of ELS which are on the scope of this research. These systems have not been developed because of non-feasibility of their complexity of their design and development and they could be taken for further research.

ELS (E-Learning System)

5.6.2 PELS (Personalised E-Learning System)

5.6.3 A<sub>L</sub>ELS (Adaptable E-Learning System)

5.6.4 A<sub>V</sub>ELS (Adaptive E-Learning System)

5.6.5 A<sub>L</sub>PELS (Adaptable Personalised E-Learning System)

5.6.6 A<sub>V</sub>PELS (Adaptive Personalised E-Learning System)

5.6.7 AAELS (A<sub>V</sub>A<sub>L</sub>ELS) (Adaptive Adaptable E-Learning System)

5.6.8 AAPELS (A<sub>V</sub>A<sub>L</sub>PELS) (Adaptive Adaptable Personalised E-Learning System)

‘VVVVVVVV

### *Appendix 1-1 ELS (E-Learning System)*

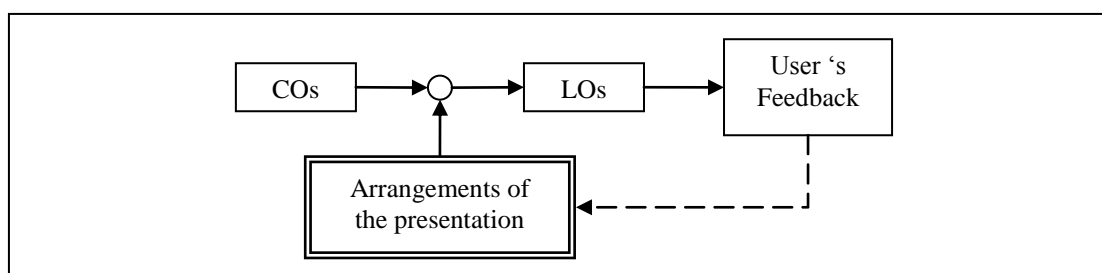
ELS is a system (categorised in this study and as sketched in Figure 61 as a type of explicit Knowledge presenter system which uses Learning Objects for its presentation component method. This type of system acts as a Learning Content Management System.

Or in another word:  $ELS = OCM + OPS-EC$  (eq ELS)

Where: ELS = Online Content Management system + an Orderly Presentation of related Subjects via existing possible methods of E-Communications.

$ELS = OCM + OPS-EC$

Or a simple Online Content Management + an Orderly Presentation of related subjects via existing possible methods of E-Communications.



**Figure 61: Schematic of ELS**

**Type of Technique used in Control unit (DMU) for the ELS:**

This is a two stage process (Table 52):

- i. The DMU section of the system receives commands from the learner to prepare a list of all available learning objects. The controlling mechanism of the system is in the state of CLFF and does not use any library-based data for its decision making process.
- ii. The System will move to the state of CLFF to prepare the complete list of all available learning objects.
- iii. The system will present the list and now the learner has access to all available resources.

| Subjects and their status                               |                      | Status of the controlling unit of the DMU and what learner's options would be through the GUI presented by the system |   |   |   |  |
|---|----------------------|---|---|---|---|--|
| Subject   | State of the subject |   |   |   |   |  |
| The DMU through the System                              | is in the state of   | CLFF  | → | CLFF  | → | CLFF   |
|   | does                 | Receiving an order to prepare a list of all available LOs   |   | Preparing and sending a list of all available LOs |   | The system will keep track of learner's activities |
| State of interaction between the Learner and the system |                      | ↕   |   | ↕   |   | ↕  |
| Learner interacting through GUI decided by DMU          | is in the state of   | Requesting for the list of LOs  |   | Receiving the list of LOs                         |   | Navigating through LOs                             |
|   | does                 | Searching for the available   |   | Viewing the list of all                           |   | Selecting and going through                        |

|  |  |   |  |               |  |                |
|--|--|---|--|---------------|--|----------------|
|  |  | options on sending the command on a request for the list of LOs (navigating through a webpage and looking for a link) |  | available LOs |  | individual LOs |
|--|--|---|--|---------------|--|----------------|

**Table 52: Stages of techniques and interaction between Control Unit (DMU) and a Learner for the ELS.**

### ***Appendix 1-2 PELS (Personalised E-Learning System)***

PELS (Personalised E-Learning System) is a category of ELS which presents LOs on the base of two instantiated values by the system itself (Figure 62); Knowledge Assessment (KA) and Learning Preference (LP) values. After the system on the base of CLFF control unit receives values – unchangeable values- list of LOs will be developed and be presented to the learner. The system will receive learner's feedback of interaction only for the purpose of survey and research.

Further explanations on different types of PELS related category of ELSs have been provided in the appendices in the production log.

### **P(LP0 / LP?, KA0 / KA?) ELS**

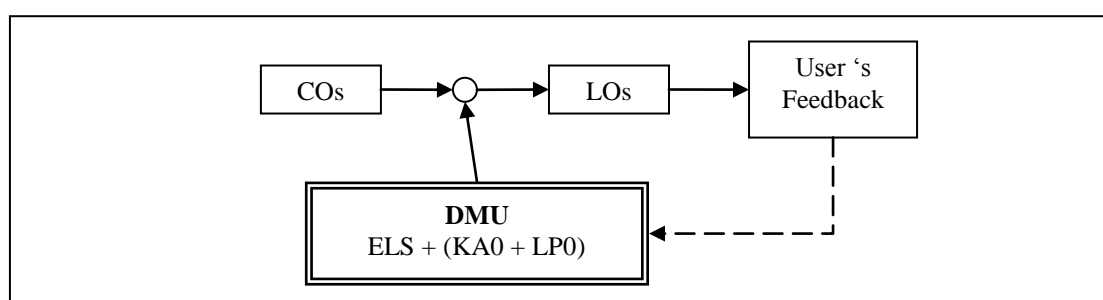
1.  $P_{LP0+KA0}$ : Personalised e-learning system with instantiated values for both learning preference and knowledge assessment by the system itself
2.  $P_{LP0+KA?}$ : Personalised e-learning system with instantiated type of learning preference by the system and selected knowledge assessment type via a questionnaire

3.  $P_{LP?+KA0}$ : Personalised e-learning system with instantiated type of learning preference via a questionnaire and selected knowledge assessment type instantiated by the system
4.  $P_{LP?+KA?}$ : Personalised e-learning system with instantiated type of learning preference and selected knowledge assessment via a questionnaire

The DMU sector of the system makes its decision on the basis of instantiated values for both KA and LP. The system will not put the user's feedback into decision making process.

PELS = Personalised ELS

PELS = ELS + (KA0 + LP0)



**Figure 62: Schematic of PELS**

### **Type of Technique used in Control unit (DMU) for the PELS:**

This is a three section mechanism (Table 53):

- i. The system instantiated by two values. KA and LP. At this stage the system is in the state of CLFF.
- ii. From now on, the system is on the control of creating and preparing a list of learning objects based on instantiated values of KA and LP.
- iii. At this stage, it is the will of the learner to navigate through existing, accessible and relevant learning objects.



- iv. The system interaction would be on the basis of CLFF from learner’s point of view, as all he sees, is that the system receives feedback from somewhere and interacting on the base of learner’s feedback given to the system.

| Subjects and their status                               |                      | Status of the controlling unit of the DMU and what learner’s options would be through the GUI presented by the system  |   |  |   |  |
|---|----------------------|--|---|--|---|--|
| Subject   | State of the subject |  |   |  |   |  |
| The DMU through the System                              | is in the state of   | CLFF   | → | CLFF   | → | CLFF   |
|   | does                 | i) Receiving the order to access the PELS by the learner (CLFF);<br>ii) The system checks for the instantiated values for KA and LP from the systems’ library. |   | Preparing and sending a list of LOs based on instantiated values |   | The system will be keeping track of learner’s activities |
| State of interaction between the Learner and the system |                      | ↕  |   | ↕  |   | ↕  |
| Learner interacting through GUI decided by DMU          | is in the state of   | An index list of sending requests  |   | Receiving a list of LOs decided by DMU                           |   | Navigating through LOs                                   |
|   | does                 | Requesting to view the list of LOs   |   | Viewing the list of LOs  |   | Selecting and going through individual LOs               |

**Table 53: Stages of techniques and interaction between Control Unit (DMU) and a Learner for the PELS.**

**Appendix 1-3 A<sub>I</sub>ELS (Adaptable E-Learning System)**

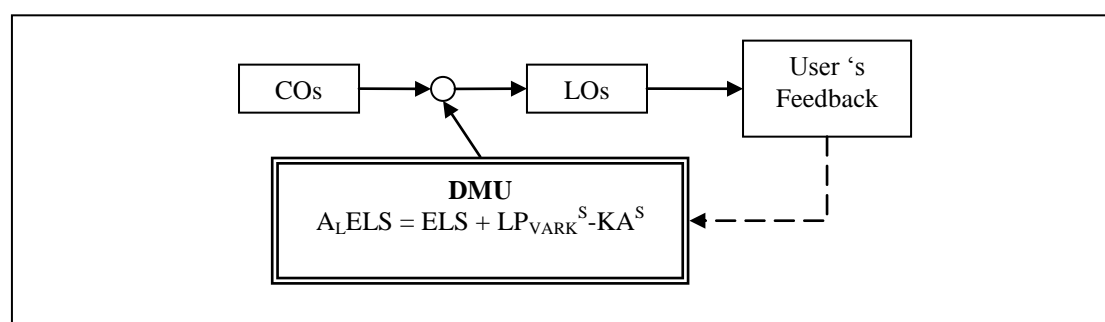
In this category, LOs would be chosen by DMU on the base of identifying a learner’s Knowledge Assessment and/or Learning Preference (LP) and then creating LOs based on those instantiated values of KA-LP related content materials (Figure 63).

$$A_I\text{ELS} = \text{ELS} + \text{LP}^S\text{-KA}^S\text{-CO} [\text{ELS} + \text{LP}_{\text{VARK}}^{\text{Static}}\text{-KA}^{\text{Static}}\text{-CO}]$$

LP<sub>VARK</sub><sup>S</sup>-KA<sup>S</sup>-CO: Static type of learning preference-based with static type of knowledge assessment-based content objects, where LP is based on VARK

assessment and it is determined statically via a questionnaire. The same thing goes to KA, by having an outcome of a knowledge assessment test.

Above values could be altered again via a set of options provided by control unit. In another word, once they have been determined, they will not be changed by the system but the learner. The learner has the option of changing the LP and KA based key element as many times as he/she wants to. Content materials contain all course materials.



**Figure 63: Schematic of  $A_L ELS$ .**

### **Different possible types of $A_L(LP0 / LP?, KA0 / KA?) ELS$**

1.  $A_{L-LP0+KA0}$ : Adaptable e-learning system with instantiated values for both learning preference and knowledge assessment by the system
2.  $A_{L-LP0+KA?}$ : Adaptable e-learning system with instantiated type of learning preference by the system and selected knowledge assessment via a questionnaire
3.  $A_{L-LP?+KA0}$ : Adaptable e-learning system with instantiated type of learning preference via a questionnaire and instantiated selected knowledge assessment by the system
4.  $A_{L-LP?+KA?}$ : Adaptable e-learning system with instantiated type of learning preference and selected knowledge assessment via a questionnaire

### **Type of Technique used in Control unit (DMU) for the $A_L ELS$ :**

This is a three section mechanism (Table 54):

- i. A learner takes an LP-KA test (Learning Preferences/Knowledge Assessment test). The system updates learner's learning profile with new information and stores them in a library so to be accessed by the DMU later on.
- ii. By the completion of test(s), the control unit would make its decisions on the base of learner's test outcome(s) and creates a new list of Learning Objects. This list will be presented to the learner at the time of his request. At this stage the control unit is on the state of CLFF which in turn it will make its decisions based on feedbacks received from learner.
- iii. At this stage, it is the will of the learner to navigate through existing, accessible and relevant learning objects.

| Subjects and their status                               |                      | Status of the controlling unit of the DMU and what learner's options would be through the GUI presented by the system |   |  |   |  |
|---|----------------------|---|---|--|---|--|
| Subject   | State of the subject |   |   |  |   |  |
| The DMU through the System                              | is in the state of   | CLFF  | → | CLFF   | → | CLFF   |
|   | Does                 | Updating LH-DB  |   | Preparing a list of LOs based on LP-KA-based outcome from the library and by reading instantiated data |   | The system will be keeping track of learner's activities and checking if there is another update on his Knowledge assessment |
| State of interaction between the Learner and the system |                      | ↕   |   | ↕  |   | ↕  |
| Learner interacting through GUI decided by DMU          | is in the state of   | LP/KA Test  |   | Receiving a New list of LOs decided by DMU   |   | Navigating through LOs   |
|   | Does                 | LP and/or KA Test(s)  |   | Viewing the list of LOs developed based on his LP-KA   |   | Selecting and going through individual LOs   |

**Table 54: Stages of techniques and interaction between Control Unit (DMU) and a Learner for the PEELS.**

#### *Appendix 1-4 AvELS (Adaptive E-Learning System)*

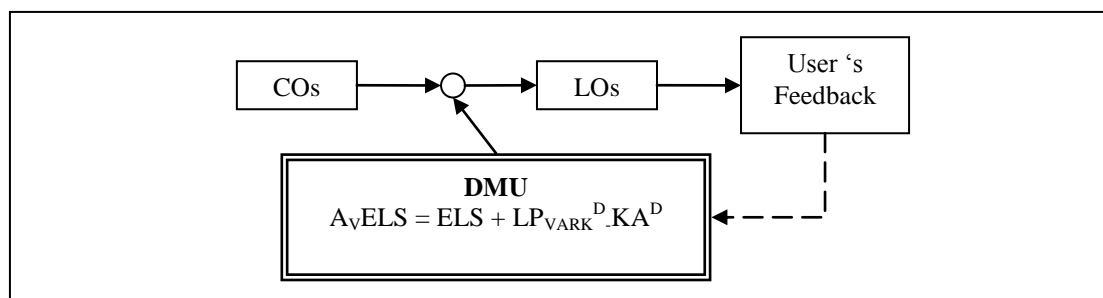
$A_V$ ELS is a category of ELS, which DMU itself is responsible for recognising learner's LP-KA (Figure 64). There is no LP test used for determining a learner's LP-KA. Recognising this preference is based on a dynamic interaction with the learner.

$$A_V\text{ELS} = \text{ELS} + \text{LP}^D - \text{KA}^D - \text{CO} \quad [\text{ELS} + \text{LP}_{\text{VARK}}^{\text{Dynamic}} - \text{KA}^{\text{Dynamic}} - \text{CO}]$$

### **Different possible types of $A_V$ (LP0 / LP?, KA0 / KA**

1.  $A_V\text{-LP0+KA0}$ : adaptive e-learning system with instantiated values for the type of learning preference and knowledge assessment by the system
2.  $A_V\text{-LP0+KA?}$ : adaptive e-learning system with instantiated value for the type of learning preferences by the system and the instantiated value for the knowledge assessment via a questionnaire
3.  $A_V\text{-LP?+KA0}$ : adaptive e-learning system with instantiated values for learning preferences via a questionnaire and instantiated value for knowledge assessment by the system
4.  $A_V\text{-LP?+KA?}$ : adaptive e-learning system with instantiated values for both learning preferences and knowledge assessment via a questionnaire

$\text{LP}_{\text{VARK}}^D - \text{KA}^D - \text{CO}$ : Dynamic type of Learning Preference-(and/or)-Knowledge Assessment-outcome-based content objects, where LP is based on VARK and it is determined dynamically via continues interaction with learner and changes continuously with the pass of time. There is no questionnaire used for this purpose. Content materials contain KA-based course materials and the type of determined-LP by the system.



**Figure 64: Schematic of AvELS**

**Type of Technique used in Control unit (DMU) for the AvELS:**

- i. A learner initiates the system by starting the interaction process (Table 55).
- ii. As the system does not have any record from the learner, it starts to prepare a set of LOs from its instantiated values set by the system. Details of this process are given on the next step.
- iii. The learner starts to interact with the system while the system keeps track of learner's interaction (CLFB).
- iv. The learner will be given a set of LOs on the base of a specific LP-KA (CLFB); and then they will be changed to different variables on the base of learner's feedback in the form of analysing learner's learning performance (CLFF).
- v. Now the controlling mechanism of the system would be on the base of CLFF. The system already has made a distinction between available types of learning objects and ready to present to the learner. At this stage, it is the will of the learner to navigate through existing, accessible and relevant learning objects.

| Subjects and their status  |                      | Status of the controlling unit of the DMU and what learner's options would be through the GUI presented by the AvELS system |   |   |   |   |
|----------------------------|----------------------|---|---|---|---|---|
| Subject                    | State of the subject |   |   |   |   |   |
| The DMU through the System | is in the state of   | CLFB  | → | CLFB  | → | CLFF  |
|                            | Does                 | Updating LH-DB<br>The library of  |   | Preparing a list of LOs based on instantiated values set by the |   | The system continues to keep track of learner's |

|   |                    |   |  |  |  |  |
|---|--------------------|---|--|--|--|--|
|   |                    | learner's activities  |  | system   |  | activities and checking if there is another update on his performance while using a specific type of LP-KA |
| State of interaction between the Learner and the system |                    | ↕   |  | ↕  |  | ↕  |
| Learner interacting through GUI decided by DMU          | is in the state of | Initiating the System   |  | Receiving a New list of LOs decided by DMU                 |  | Navigating through LOs   |
|   | Does               | Initiating the system by requesting to go through available LOs |  | Viewing the list of LOs developed based on learner's LP-KA |  | Selecting and going through individual LOs   |

**Table 55: Stages of techniques and interaction between Control Unit (DMU) and a Learner for the A<sub>v</sub>ELS.**

**Appendix 1-5 A<sub>l</sub>PELS (Adaptable Personalised E-Learning System)**

>>> For further information the reader is referred back section 4.8.1. <<<

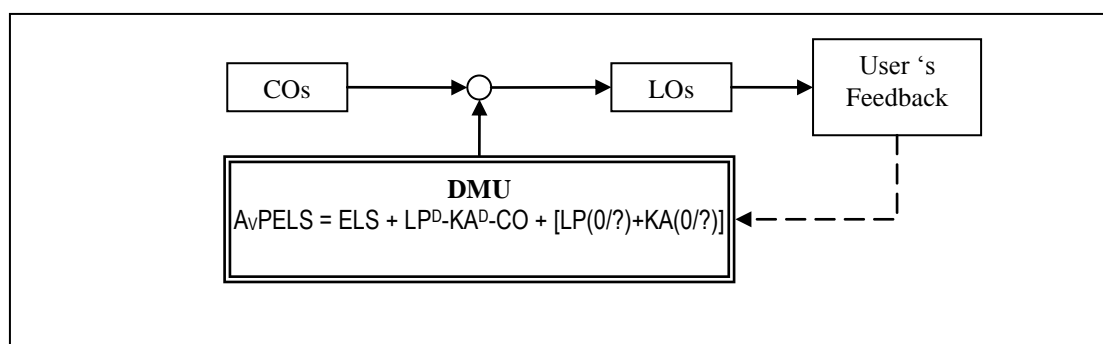
**Appendix 1-6 A<sub>v</sub>PELS (Adaptive Personalised E-Learning System)**

A<sub>v</sub>ELS is a category of ELS, which DMU itself is responsible for recognising learner's LP and KA levels (Figure 65). There is no LP-KA-based test used for determining a learner's LP. Recognising this preference should be based on a dynamic interaction with the learner, in another word, the system should learn on how to increase the learning performance of the learner.

$$A_vPELS = ELS + LP^D-KA^D-CO + [LP(0/?)+KA(0/?)]$$

$$A_vPELS = ELS + LP_{VARK}^{Dynamic}-KA^{Dynamic}-CO + [LP(0/?)+KA(0/?)]$$

LP<sub>VARK</sub><sup>Dynamic</sup>-KA<sup>Dynamic</sup>-CO + [LP(0/?)+KA(0/?)]: Dynamic type of Learning Preference-based content objects, where LP is based on VARK and KA are determined dynamically via continues interaction with learner and changes continuously with time. There is no questionnaire used for this purpose. There is



**Figure 65: Schematic of AvPELS**

**Type of Technique used in Control unit (DMU) for the AvPELS:**

This is a three section mechanism (Table 56):

- i. The system is responsible for finding learner's LP and/or KA types via progressive and continuous changes on changing values for LP-KA instantiative values (CLFB). This type of system un-like  $A_LPELS$ , will not be getting any input from the learner. It is a kind of self-contained system where all instantiation and changes to the system are done within the system.
- ii. The system updates learner's learning profile with this information.
- iii. By finding instantiated values, then the system won't change on that specific type. By the completion of the test, the control unit would make its decisions on the base of learner's LP test outcome and creates a new list of Learning Objects. This list will be presented to the learner at the time of his request. At this stage the control unit is on the state of CLFF. It makes its decisions based on feedbacks received from learner.
- iv. From now on, the system is on the control of creating and preparing a list of learning objects based on learner's learning preferences and knowledge assessment outcome of the topic. In this case the system would be on control and as such the status of the system would be CLFF.

| Subjects and their status                               |                      | Status of the controlling unit of the DMU and what learner's options would be through the GUI presented by the system |   |   |   |  |
|---|----------------------|---|---|---|---|--|
| Subject   | State of the subject |   |   |   |   |  |
| The DMU through the System                              | is in the state of   | CLFF  | → | CLFB  | → | CLFF   |
|   | Does                 | Waiting to receive the initiation processing message send by the learner  |   | Updating the library of learner's activities and preparing a list of LOs on the base of LP-KA |   | The system will keep track of learner's activities and checking if there is another update on his relevant LP-KA |
| State of interaction between the Learner and the system |                      | ↕   |   | ↕   |   | ↕  |
| Learner interacting through GUI decided by DMU          | is in the state of   | Starting to receive the list of LOs   |   | Receiving a New list of LOs decided by DMU  |   | Navigating through LOs   |
|   | Does                 | Sending an initiation message to the system as a request  |   | Viewing the list and working through published LOs  |   | Selecting and going through individual LOs   |

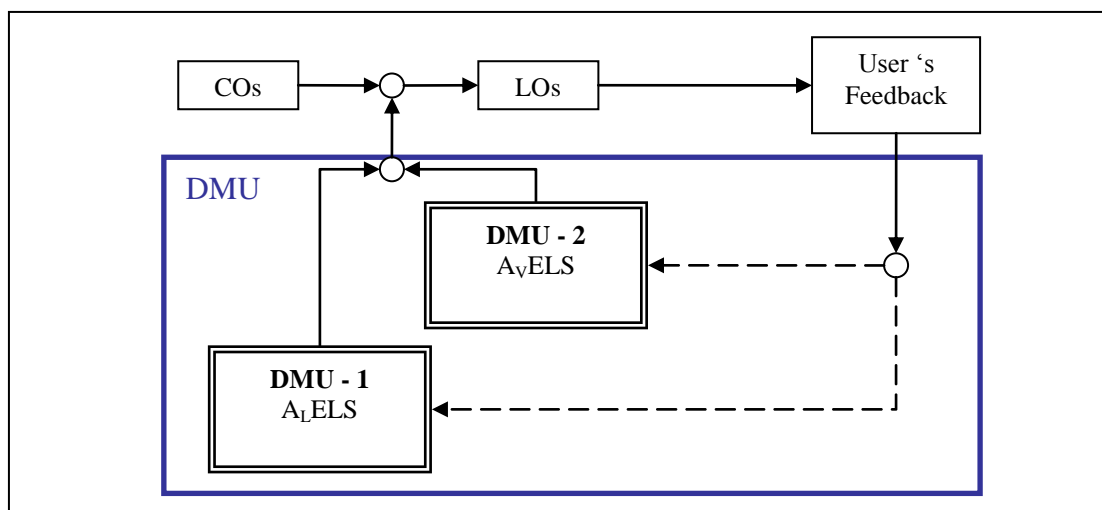
**Table 56: Stages of techniques and interaction between Control Unit (DMU) and a Learner for the A<sub>v</sub>PELS.**

### ***Appendix I-7 AAELS (A<sub>v</sub>A<sub>L</sub>ELS) (Adaptive Adaptable E-Learning System)***

AAELS is a category of ELS, which is a collection of two types of DMUs (Figure 66). At the beginning of the course A<sub>L</sub>ELS would determine learner's LP-KA via a set of questionnaire or by giving an option to select relevant changes to the LP-KA values as part of instantiation values. Then the system would continue evaluating learner's interaction with the system and readjust the LP-KA set by the learner.

$$AAELS = A_vELS + A_LELS$$





**Figure 66: Schematic of  $A_L A_V ELS$**

**Type of Technique used in Control unit (DMU) for the  $A_V A_L ELS$ :**

This is a three section mechanism (Table 57):

- i. The learner takes the relevant LP-KA test. The system updates learner's learning profile with this information (CLFF).
- ii. From now on, the system is on the control of creating and continuous updating the list of LOs (CLFB).
- iii. Now the controlling mechanism of the system would be on the base of CLFF. The system has already made a distinction between available types of learning objects and is ready to present them to the learner.
- iv. Learner will navigate through provided LOs and the system will keep track of learner's activities and his performance to make necessary changes to the system.

| Subjects and their status |                      | Status of the controlling unit of the DMU and what learner's options would be through the GUI presented by the system |
|---------------------------|----------------------|---|
| Subject                   | State of the subject |   |
|                           |                      |   |

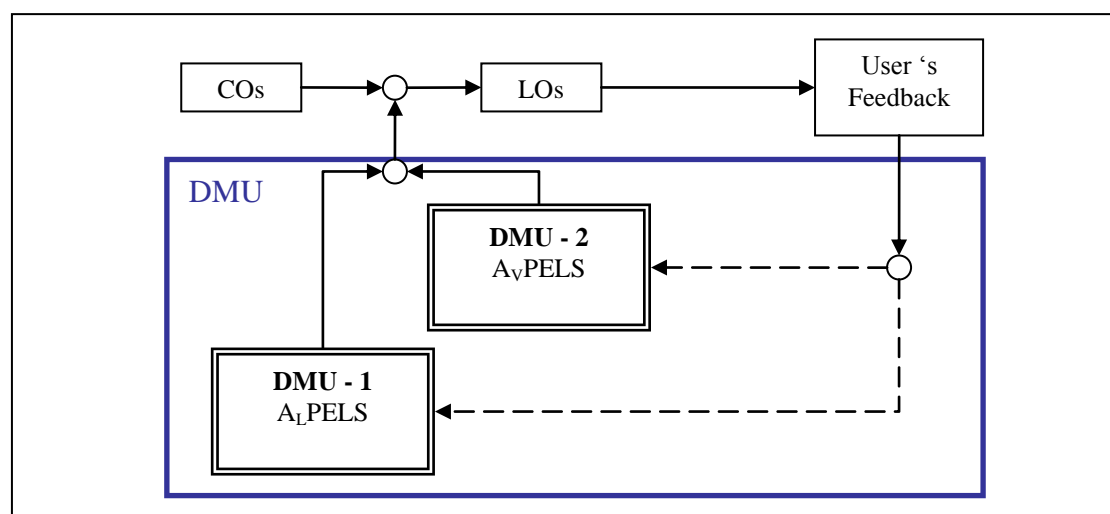
|   |                    |  |   |  |   |   |
|---|--------------------|--|---|--|---|---|
| The DMU through the System                              | is in the state of | CLFF                                     | → | CLFB   | → | CLFF  |
|   | Does               | Updating LH-DB                           |   | Continuously updating the library of learner's activities based on his learning performance and preparing a list of LOs base on relevant LP-KA |   | The system keeps track of learner's activities and checking if there is another update on LP-KA |
| State of interaction between the Learner and the system |                    | ↕  |   | ↕  |   | ↕   |
| Learner interacting through GUI decided by DMU          | is in the state of | Giving feedback on requested LP-KA tests |   | Receiving a New list of LOs decided by DMU   |   | Navigating through LOs  |
|   | Does               | Taking relevant LP-KA tests              |   | Viewing the list and working through published LOs   |   | Selecting and going through individual LOs  |

**Table 57: Stages of techniques and interaction between Control Unit (DMU) and a Learner for the  $A_L A_V$ ELS.**

**Appendix 1-8 AAPELS ( $A_V A_L$ PELS) (Adaptive Adaptable Personalised E-Learning System)**

The only difference between AAELS and AAPELS is on the updating process of relevant LP-KA on the selection of course materials (Figure 67).

$$AAPELS = A_VPELS + A_LPELS$$



**Figure 67: Schematic of  $A_L A_V$ PELS**

### **Type of Technique used in Control unit (DMU) for the A<sub>v</sub>A<sub>L</sub>PELS:**

This is a three section mechanism (Table 58):

- i. The learner takes the relevant LP-KA test. The system updates learner's learning profile with this information (CLFF).
- ii. From now on, the system is on the control of creating and continuous updating the list of LOs (CLFB).
- iii. Now the controlling mechanism of the system would be on the status of CLFF.  
The system has already made a distinction between available types of learning objects and is ready to present them to the learner.
- iv. Learner will navigate through provided LOs and the system will keep track of learner's activities and his performance to make necessary changes to the system.

| Subjects and their status                               |                      | Status of the controlling unit of the DMU and what learner's options would be through the GUI presented by the system |   |  |   |   |
|---|----------------------|---|---|--|---|---|
| Subject   | State of the subject |   |   |  |   |   |
| The DMU through the System                              | is in the state of   | CLFF  | → | CLFB   | → | CLFF  |
|   | Does                 | Updating LH-DB  |   | Continuously updating the library of learner's activities based on his learning performance and preparing a list of LOs base on relevant LP-KA |   | The system keeps track of learner's activities and checking if there is another update on LP-KA |
| State of interaction between the Learner and the system |                      | ↕   |   | ↕  |   | ↕   |
| Learner interacting through GUI decided by DMU          | is in the state of   | Giving feedback on requested LP-KA tests  |   | Receiving a New list of LOs decided by DMU   |   | Navigating through LOs  |
|   | Does                 | Taking relevant LP-KA tests   |   | Viewing the list and working through published LOs   |   | Selecting and going through individual LOs  |

**Table 58: Stages of techniques and interaction between Control Unit (DMU) and a Learner for the A<sub>L</sub>A<sub>v</sub>PELS.**

***Appendix 1-9 Concluding Remarks [Needs revising]***

In this chapter different key elements involved on the process of making a decision on designing an e-learning system were studied. Factors such as decision maker unit, feedback-based control systems and learning about categorisation of different types of e-learning systems were part of main topics which were discussed in this chapter. The current system would be used to gather learners' interaction with different learning environment based on their learning preferences and so to find any relationship between both (types of systems used and their LPs) and their learning performance (section 1.3).

In the following chapter the third phase of the system will be discussed which is the development stage of this study. As far as this study is concerned, the framework of design and development of the e-learning system would be Adaptable Personalised E-Learning System (A<sub>L</sub>PELS).

## Appendix 2      Creating a template on developing COs

Table of “Categorising types of COs” could be used and be a benchmark towards developing a template for any future creation of LOs. The table would show what types of DAs are needed for any COs; and then LO would be developed on the base of these COs.

For example let’s consider developing a LO for one of lessons on “CIS Induction” course.

***Title of the lesson:***    Effective Web Searching

***Objectives:***

For simplicity, as part of identifying objectives, let’s consider its manipulated table of contents as a list of Objectives from the following web address:

<http://www.lib.ncsu.edu/staff/kcollins/web.html>

so they would be:

- Identifying needs on reasons for web searching
- Evaluating found contexts
- Defining a Search Engine
- Defining Meta-Search Engines
- Suggested tips on doing a search
- Defining a Subject Directory
- Few suggested search engines
- Defining Citation and Citing Web Sources

### **Paper-based contexts:**

Each objective has been described on a paper-based and mostly Text-based form, as below:

Start of fulfilling the first objective:

{{{

#### **When to Search the Web**

Not all topics are equally represented on the web. Chances are good that you will find what you want by searching the web when your topic is related to:

9. an academic institution (departments, research programs, contact information, etc.)
10. a government agency or non-profit organization (research, publications, legislation, etc.)
11. a well-known organization or business
12. computers
13. current newspapers, tv, or radio

14. current events/celebrities
15. something that is interesting to a lot of people, such as cooking or movies
16. anything trendy

You will be less likely to find what you want on the web when your topic:

- is over two years old (sometimes only one year)
- requires in-depth coverage
- is very narrow

Keep in mind that if you search only the web, you are limiting yourself to articles that the publishers make available for free. Perhaps this is because the publisher is a non-profit organization, or because your tax dollars paid for it. On the other hand, perhaps it is because they want to sell you something else and can lure you in with articles, or so they can sell your wandering eyes to advertisers, or because no one would pay for the information. So if you don't want to severely compromise your research from the outset, use [library databases](#) in addition to the web.

For more on this topic, see [The Issue of Quality on the Internet](#). See also [Point. Click. Think?: As Students Rely on the Internet for Research, Teachers Try to Warn of the Web's Snares](#).

For a good introduction to web searching and more, try out [TILT](#), an interactive tutorial sponsored by the University of Texas System Digital Library.

}}}

Other objectives could be configured as above sample.

**Content Objects:**

Learning Section of a Learning Object

Label 1:  
Title of the 1<sup>st</sup> section for Layer 2 of Learning Section

**When to Search the Web**

Paragraph1:

Not all topics are equally represented on the web. Chances are good that you will find what you want by searching the web when your topic is related to:

- an academic institution (departments, research programs, contact information, etc.)
- a government agency or non-profit organization (research, publications, legislation, etc.)
- a well-known organization or business
- computers
- current newspapers, tv, or radio
- current events/celebrities
- something that is interesting to a lot of people, such as cooking or movies
- anything trendy

Label 2:  
Title of the 1<sup>st</sup> section for Layer 2 of Learning Section

**When to Search the Web**

Paragraph2:

You will be less likely to find what you want on the web when your topic:

- is over two years old (sometimes only one year)
- requires in-depth coverage
- is very narrow

Label 3:  
Title of the 1<sup>st</sup> section for Layer 3 of Learning Section

**When to Search the Web - 3**

Paragraph3:

Keep in mind that if you search only the web, you are limiting yourself to articles that the publishers make available for free. Perhaps this is because the publisher is a non-profit organization, or because your tax dollars paid for it. On the other hand, perhaps it is because they want to sell you something else and can lure you in with articles, or so they can sell your wandering eyes to advertisers, or because no one would pay for the information. So if you don't want to severely compromise your research from the outset, use [library databases](#) in addition to the web.

Practice Section of a Learning Obejct

Label 3:  
Title of the 2<sup>nd</sup> section for Layer 4 - Practice Section

**Practice on searching for Web Resources**

Paragraph4:

For more on this topic, see

- [The Issue of Quality on the Internet](#)
- [Point. Click. Think?: As Students Rely on the Internet for Research, Teachers Try to Warn of the Web's Snares](#)
- [TILT](#)



Now, by separating an existing Text to different paragraphs, next step starts, which is developing other types of VARK (in this case, VAWK – WK would be related to Output from Human Perspective) out of this text.

In this manner, another skill of instructional designer glorifies its performance as being a designer by having the ability of converting variety of Digital Assets together.

#### V – Form of Paragraph 2



#### A – Form of Paragraph 2

Click here for an explanation. 

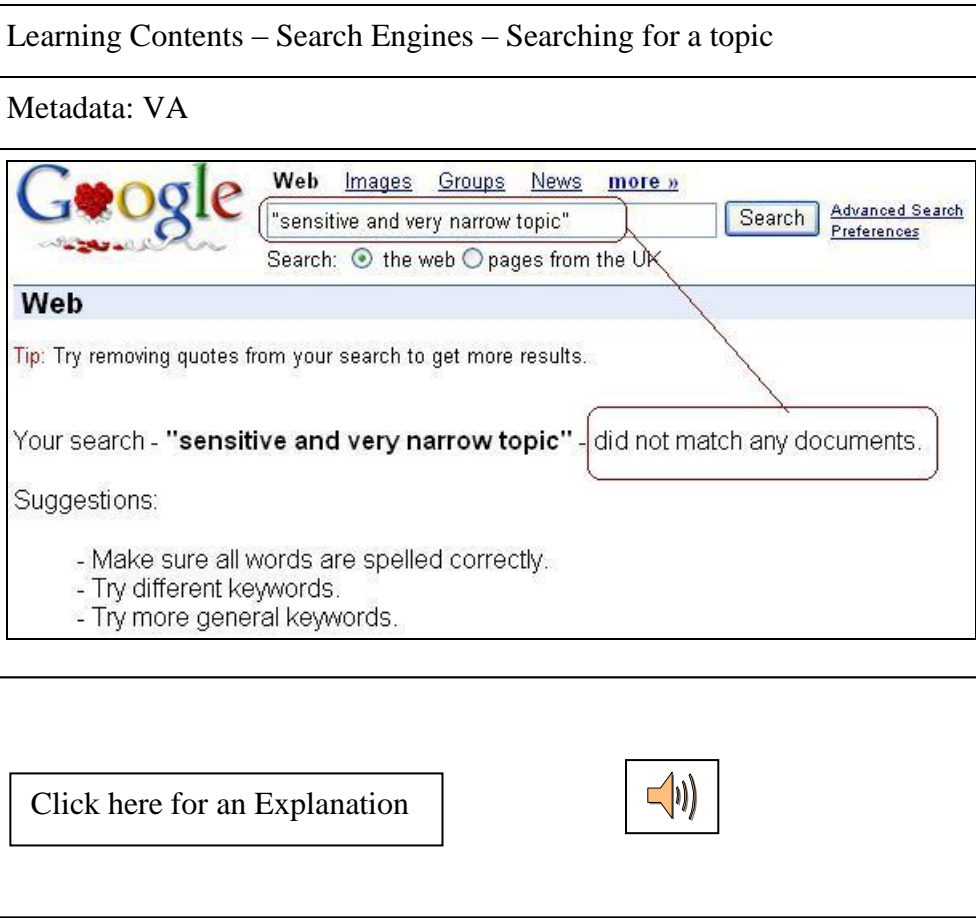
After preparing these DAs, now it is time to prepare a sample of COs.

There would be 4 different types of COs as mentioned earlier.

CO1: VA

Learning Contents – Search Engines – Searching for a topic

Metadata: VA



Google Web Images Groups News [more »](#)

"sensitive and very narrow topic" Search [Advanced Search](#) [Preferences](#)

Search:  the web  pages from the UK


**Web**

Tip: Try removing quotes from your search to get more results.

Your search - **"sensitive and very narrow topic"** - did not match any documents.


Suggestions:

- Make sure all words are spelled correctly.
- Try different keywords.
- Try more general keywords.


[Click here for an Explanation](#) 

Note: in the real demo by clicking on the “Speaker” icon, a reader gives a description on what has been presented on the slide above through reading the contents given in the slid.



CO2: VR

|   |
|---|
| Learning Contents – Search Engines – Searching for a topic  |
| Metadata: VR  |
| You will be less likely to find what you want on the web when your topic: <ul style="list-style-type: none"><li>• is over two years old (sometimes only one year)</li><li>• requires in-depth coverage</li><li>• is very narrow</li></ul>   |
|  <p>The screenshot shows the Google search interface. At the top, the Google logo is on the left, and navigation links for 'Web', 'Images', 'Groups', 'News', and 'more »' are on the right. A search bar contains the text '"sensitive and very narrow topic"'. To the right of the search bar is a 'Search' button and links for 'Advanced Search' and 'Preferences'. Below the search bar, there are radio buttons for 'the web' (selected) and 'pages from the UK'. The main content area has a 'Web' header. A tip says 'Try removing quotes from your search to get more results..'. Below that, it says 'Your search - "sensitive and very narrow topic" - did not match any documents.' A box highlights this message, with a red arrow pointing from the search bar to it. Underneath, 'Suggestions:' are listed: '- Make sure all words are spelled correctly.', '- Try different keywords.', and '- Try more general keywords.'</p> |

CO3: AR

|  |
|--|
| Learning Contents – Search Engines – Searching for a topic   |
| Metadata: AR   |
| <p>You will be less likely to find what you want on the web when your topic:</p> <ul style="list-style-type: none"><li>• is over two years old (sometimes only one year)</li><li>• requires in-depth coverage</li><li>• is very narrow</li></ul> |
| <p><a href="#">Click here for an Explanation</a></p>   |

CO4: VAR

|  |
|--|
| Learning Contents – Search Engines – Searching for a topic   |
| Metadata: VAR  |
| <p>You will be less likely to find what you want on the web when your topic:</p> <ul style="list-style-type: none"><li>• is over two years old (sometimes only one year)</li><li>• requires in-depth coverage</li><li>• is very narrow</li></ul>   |
|  <p>The screenshot shows the Google search interface. The search bar contains the text "sensitive and very narrow topic". Below the search bar, it says "Search: the web pages from the UK". The search results section shows "Your search - 'sensitive and very narrow topic' - did not match any documents." and "Suggestions: - Make sure all words are spelled correctly. - Try different keywords. - Try more general keywords." A red box highlights the search input and the result message. A red arrow points from the search input to the result message.</p> |
| <p><a href="#">Click here for an Explanation</a></p>   |

## Appendix 3      Types and Methods of creating Digital Assets

| <b>NO</b> | <b>VARK types of DA</b> | <b>Full definition</b> | <b>How it would be used</b>   | <b>How it would be developed</b>  |
|-----------|-------------------------|------------------------|---|---|
| 1         | None                    | None                   | No form of any DA would be used   | Nothing to produce  |
| 2         | V                       | Visual                 | Just in the form of visual output ( such as a photo, graph, animation, ...)   | By using a photo editor application, video production tool, Flash, ...  |
| 3         | A                       | Audio                  | Just in the form of Audio output  | By using an audio production tool, Microphone to record voice, a library of sound effects, ...  |
| 4         | R                       | Read / Write           | Just in the form Read or Write  | By using a text editor application such as MS word, most of other applications have this capability and it mostly depends on what other applications have been used mostly  |
| 5         | K                       | Kinaesthetic Tactile   | In the form of Text entry in a form by using keyboard, moving objects in an animation developed by flash, ..., as this is mostly would be used with other types of categories (VARK)          | This type of VARK, would mostly be developed in relation of other types of VARK, as its main need within the category of HCI would be to interact with computer, mostly flash would be a good example of developing Kineasthetic type of Content Object |
| 6         | VA                      | Visual - Audio         | A visible person speaks about a picture, a video, an animation with moving objects around, ... the main concern here is that a voice must be included with a visual asset; the sound could be |   |
| 7         | VR                      | Visual – Read /        | In the form of a picture with a label or an explanation about   | Flash is a sample application to develop  |

|    |     |                             |  |   |
|----|-----|-----------------------------|--|---|
|    |     | Write                       | the photo, or in the form of an animation with a label (caption) or navigationable text (eg. by moving text above an icon and be prompt by some text), also, for Visual Write section it could be used to enter records or explanation to the system (this method is also partly kinaesthetic)   | such combination. However, as described earlier, the best method is to generate such CO dynamically.      |
| 8  | VK  | Visual - Kinaesthetic       | An interactive animation is an example of such Content Object  | Flash could be used to develop such CO  |
| 9  | AR  | Audio – Read / Write        | AR: A block of text with a reader who explains the contents of the text, including some additional explanation<br>AW: Although it is technically possible, but a bit difficult to generalise it for all users, as it needs specific configuration on user's computer to be able to convert user's voice to text, in form of command or normal text | Whether text converter in users machine or pre-recorded contents would be used to develop this type of CO |
| 10 | AK  | Audio - Kinaesthetic        | This combination could be used on developing CO for blind users, as user could use either keyboard or special mouse or any other entry device to interact with the system  | The system should be able to accept entries from the user to in the form of a hardware mechanical devices |
| 11 | RK  | Read /Write - Kinaesthetic  | RK: this could be done by presenting text in the form of lots of navigation, or moving text-based presented objects  | Flash would be a good example on the list of developmental application                                    |
| 12 | VAR | Visual – Audio – Read/Write | WV: Automatically typing text in a text-box of a form would fall in this category<br>VAR: While a picture or animation presented it is necessary to have some text beside the contents including visual and audio effects<br><br>VAW: this process could fall in the category of receiving feedback from the user of the                           |   |

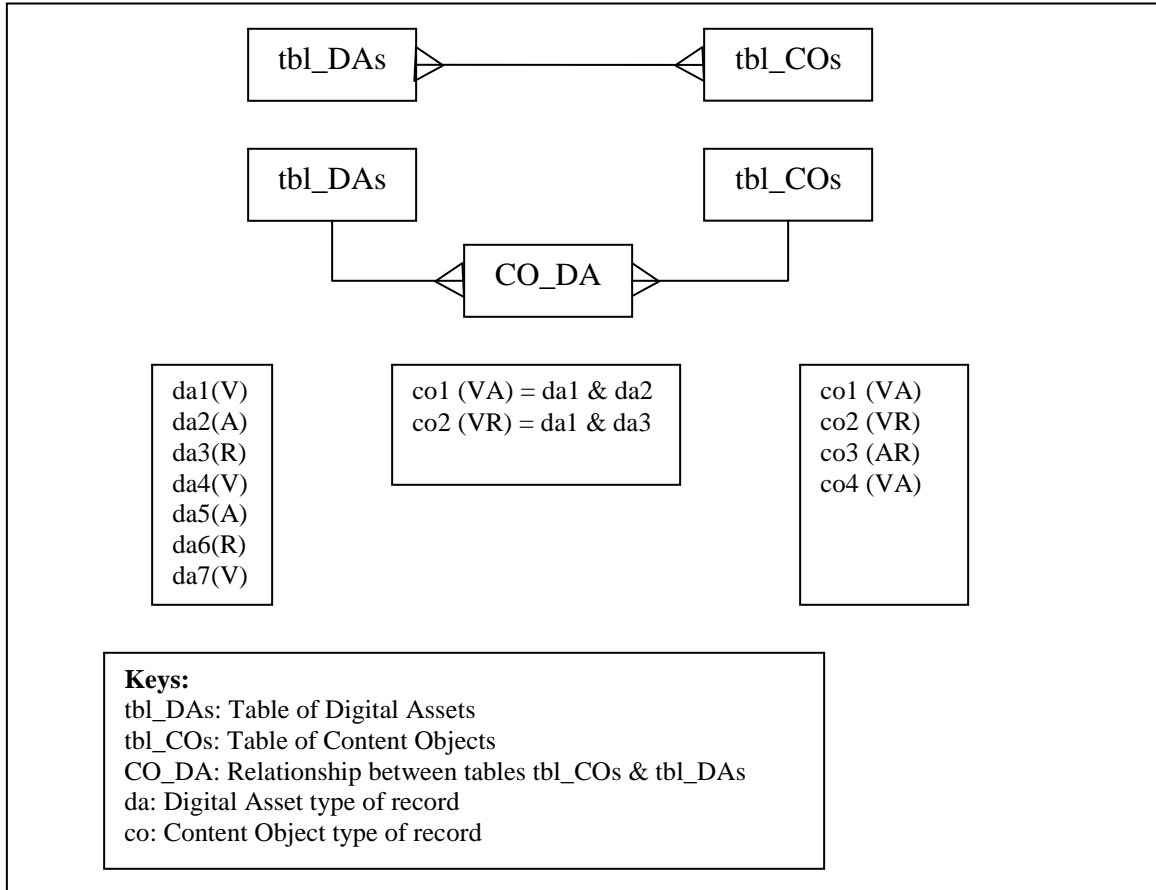
|    |      |  |   |
|----|------|--|---|
| 13 | VAK  | Visual –<br>Audio -<br>Kinaesthetic                      | system. Although this category would automatically include partly kinaesthetic, too<br>Again presenting digital assets in the form of moving objects mostly graphics would suit this category without the need for text, (however, it is better to have at least a label to present these contents)   |
| 14 | VRK  | Visual –<br>Read /<br>Write -<br>Kinaesthetic            | VRK: in this category, there is no need to have audio within CO, as user probably is more comfortable with a quite environment<br><br>VWK: this method, could be used to have user's feedback without the need for audio entries  |
| 15 | VAR  | Visual –<br>Audio –<br>Read /<br>Write                   | VAR: user likes to have a graph or animation with some voices (a presenter voice and/or audio effects) and some text but without much interaction with its contents in the form of moving objects. However it could be counted in the form of a stabilised presentation without much physical activity  |
| 16 | VARK | Visual –<br>Audio –<br>Read /<br>Write -<br>Kinaesthetic | VAW: this form of CO could be used for receiving user's feedback in the form of writing and no more physical interactivity. The writing section could be used to give command to the system for continuation or selection of a part of activities<br>This CO could be used for multi-modal people with variety of input/output capabilities.<br>VARK: to receive information from the system by giving command to the system<br>VAWK: by giving feedback to |

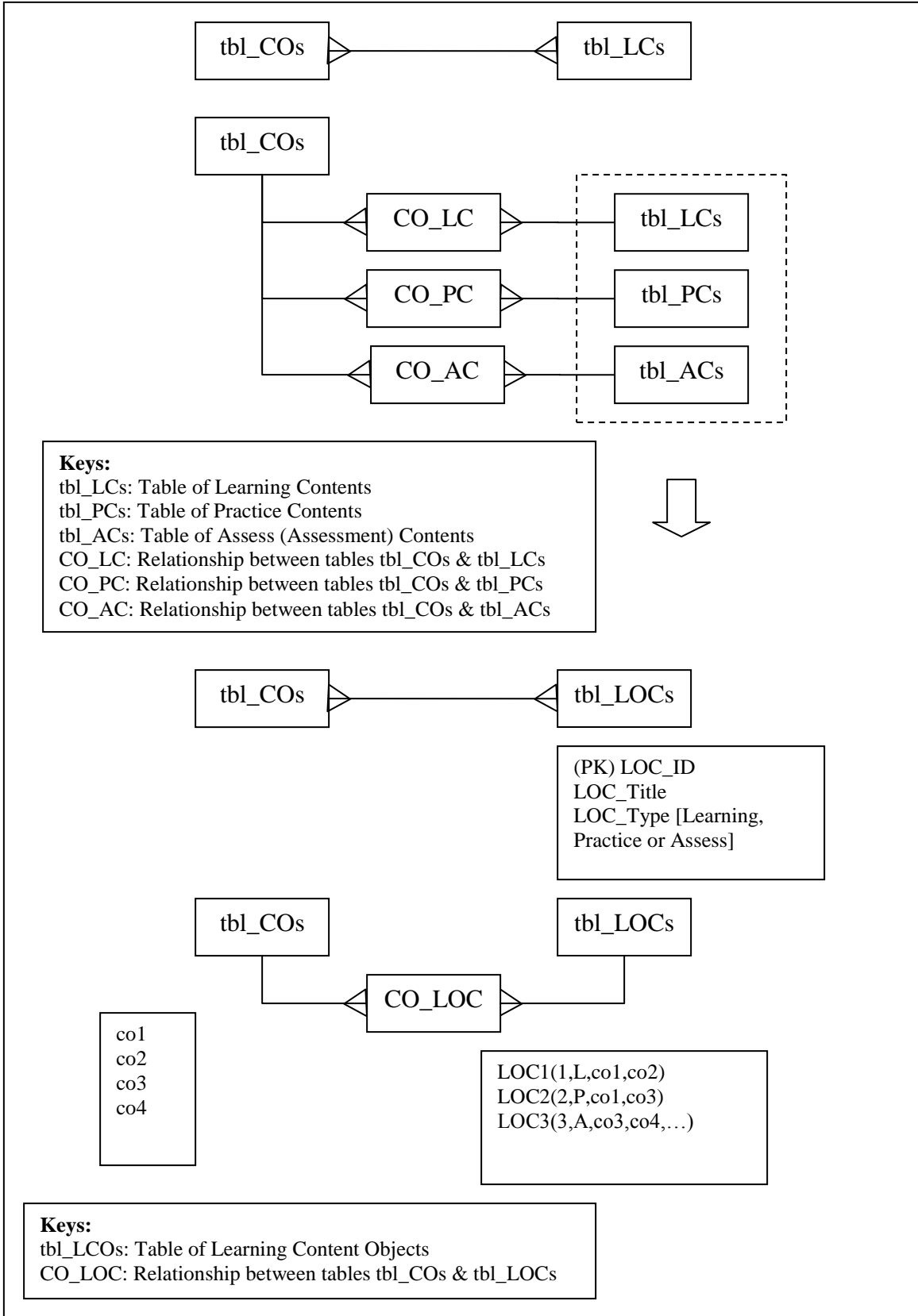


the system for his specific  
needs and knowledge  
navigation

## Appendix 4 System of Contents Provider

This appendix analyses requirements of designing a system for AvPELS. Principle of the connection between processes of developing digital assets and so developing learning preference-based contents materials and up to organising a collection known as learning object are discussed here.





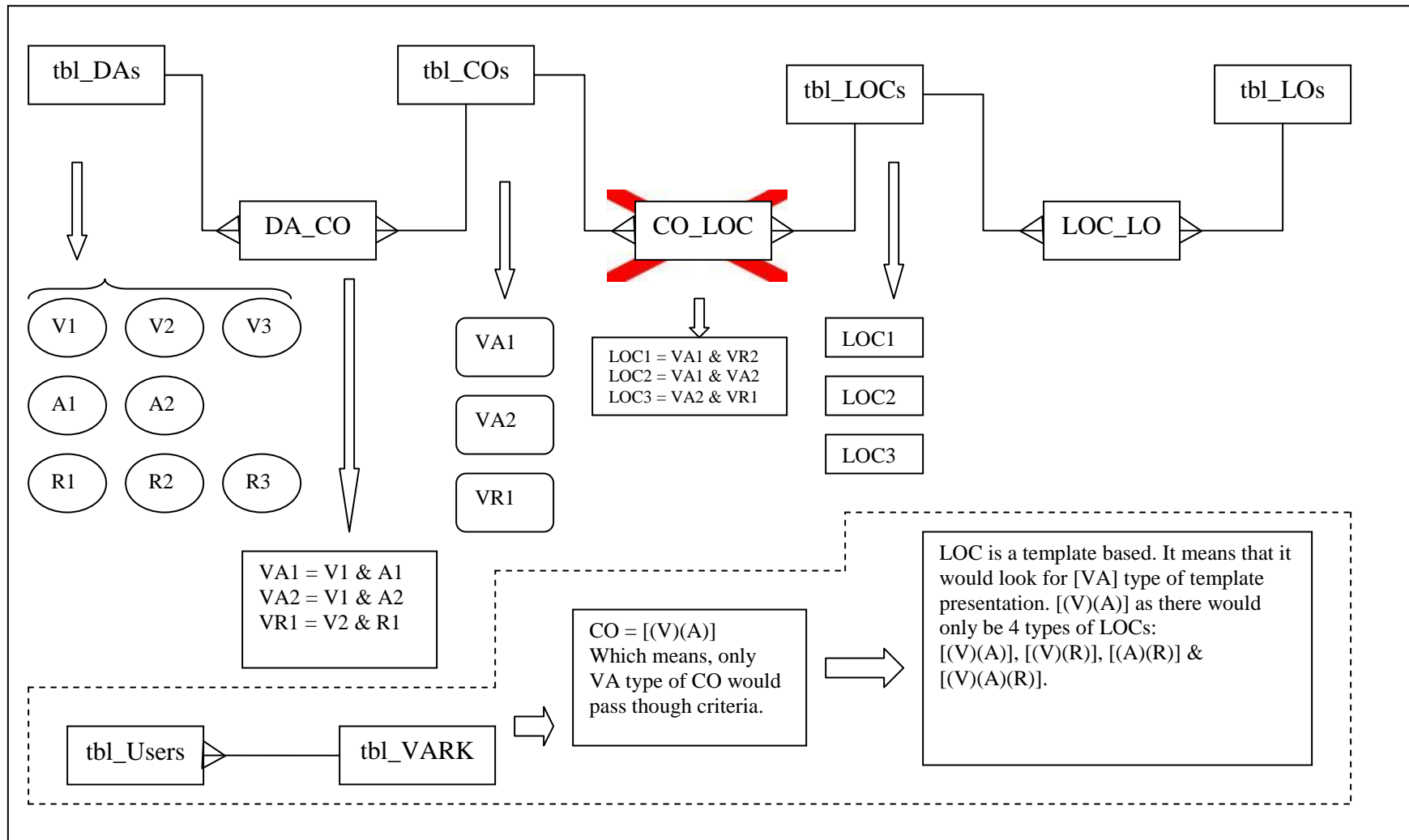
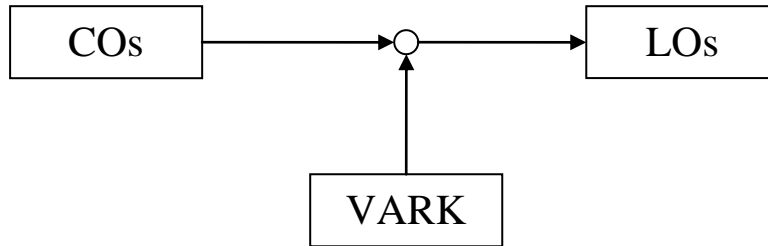


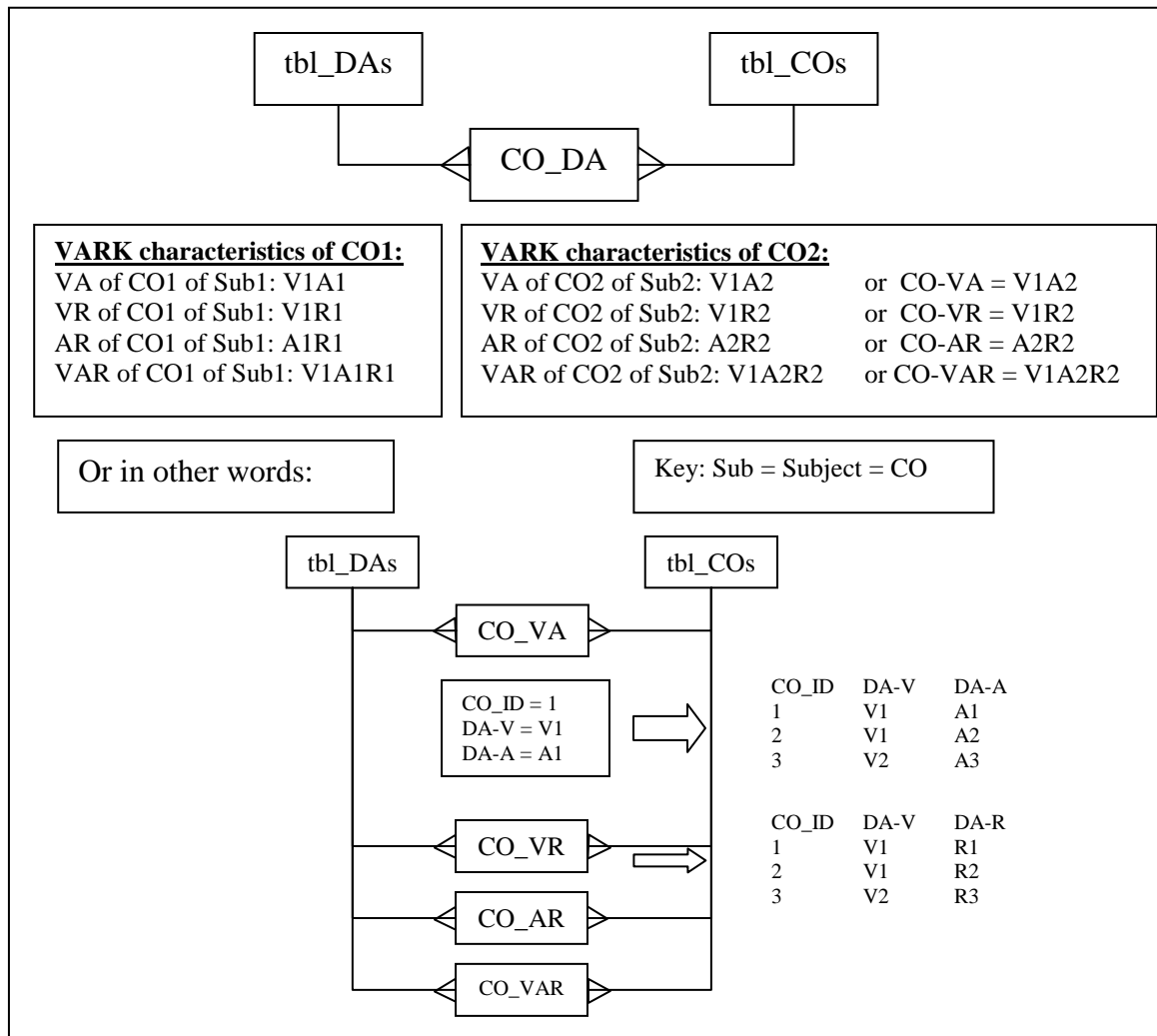
Figure:

LOCs are templates for presenting COs.

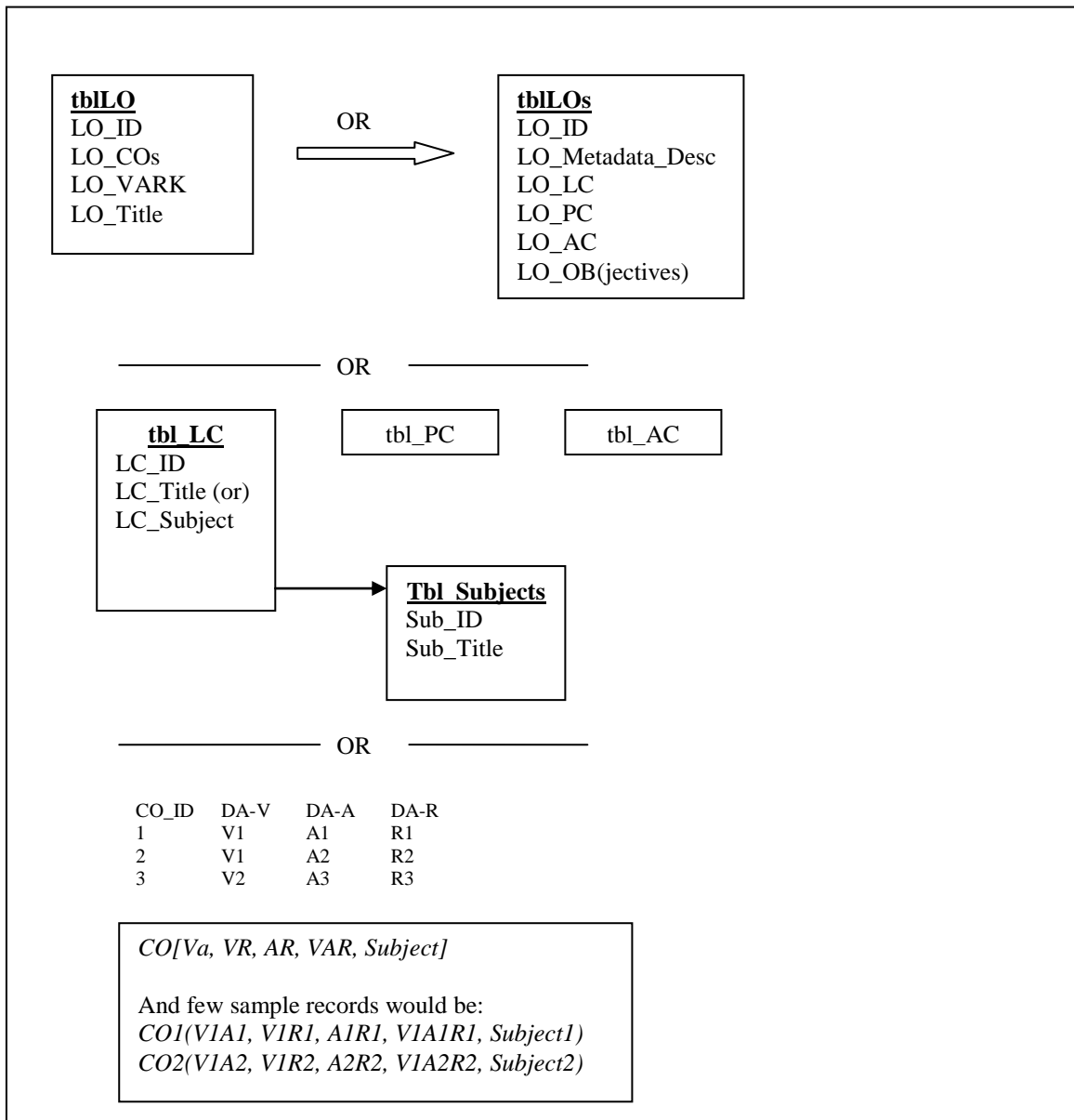
That means the main relationship would be between COs & LOs, and their presentation would be on the base of LOCs which acts as a link between specified COs and their-already-decided COs by VARK specifications.



Now let's have a sample of records for CO\_DA relationship.

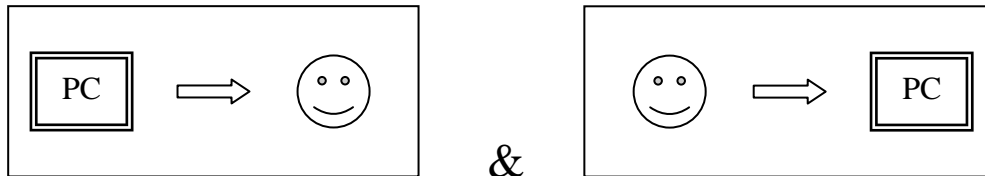


Another approach:

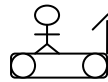


## Appendix 5 Getting ARK based DAs out of VARK based DAs concept

### Appendix A: Getting ARK based DAs out of VARK based DAs concept Getting ARK based DAs out of VARK based DAs concept



“K” means computer suppose to have a physical interaction with the user. This could be in



the form of a Treadmill: or, interaction with ears as the type of interaction would be physical movement of “Eardrum”. So, in this case “K” could be converted to “A”; and “A” on the other hand means changing the relationship between objects  $\rightarrow$  “A”  $\equiv$  Moving objects and not adding the  $A \rightarrow V$  in  $User \rightarrow PC$ .

Thus:

$VK \rightarrow VA$  (received from PC)

$VK \rightarrow$  moving objects at the time of giving feedback.

Keys:

ETB: Enterable Text Box

MO: Movable Objects (Pictures or text boxes)

In Movable Objects, relationship changes

In W (ETB) relationship is constant but number of objects change. (W stands for Write)

That’s why  $A \rightarrow V$  (MO)

$K \rightarrow (V/W)$  (either MO/ETB)

D: Dynamic

S: Static

For example:  $[V: S/D \rightarrow S \rightarrow S+S \rightarrow V+R]$  on the table means, there are two possible forms of pictures exist; either Static or dynamic types of picture and to give the right expression, a reading type of digital asset should be included.

|   | PC $\rightarrow$ User |   | User $\rightarrow$ PC |   |
|---|-----------------------|---|-----------------------|---|
| 1 | V                     | $S/D \rightarrow S \rightarrow S+S \rightarrow V+R$ | V                     | ETB/MO<br>[it depends on the type of application which presents the V. If it is a type of movable pictures then MO, if it is a type of enterable text boxes or even |

|    |      |  |       |  |
|----|------|--|-------|--|
|    |      |  |       | clickable check boxes or radio buttons then ETB.<br>For the sake of simplicity and this project, ETB would be chosen when it is possible and appropriate.] |
| 2  | A    | $D \rightarrow A$  | A     | MO [ $A \rightarrow V$ , because relationship changes]   |
| 3  | R    | $S \rightarrow S+S \rightarrow R+V (\equiv V+R)$   | W (R) | ETB [even choosing a radio button]   |
| 4  | K    | $D \rightarrow A$  | K     | MO / ETB   |
| 5  | VA   | $S/D+D \rightarrow [S \rightarrow \text{converts to } D \text{ so:}] \rightarrow D+D \rightarrow VA$ | VA    | MO<br>[ETB/MO+MO $\rightarrow$ MO]   |
| 6  | VR   | $S+S \rightarrow V+R$  | VR    | ETB<br>[ETB/MO+ETB $\rightarrow$ ETB]  |
| 7  | VK   | $S/D+D \rightarrow D+D \rightarrow V+K \equiv V+A \equiv VA$   | VK    | ETB<br>[ETB/MO+ETB/MO $\rightarrow$ ETB]   |
| 8  | AR   | $D+S \rightarrow A+R \rightarrow A+V \rightarrow D+S/D \rightarrow D+S \rightarrow VA$               | AR    | ETB*<br>[MO+ETB $\rightarrow$ ETB]   |
| 9  | AK   | $D+D \rightarrow A+A \equiv A$   | AK    | MO<br>[MO+MO/ETB $\rightarrow$ MO]   |
| 10 | RK   | $S+D \rightarrow R+K \equiv R+A \equiv RA \equiv AR \rightarrow VA$                                  | RK    | ETB<br>[ETB+ETB/MO $\rightarrow$ ETB]  |
| 11 | VAR  | $S/D+D+S \rightarrow V+A+R \equiv V+A \equiv VA$   | VAR   | ETB*<br>[ETB/MO+MO+ETB $\rightarrow$ ETB]  |
| 12 | VAK  | $S/D+D+D \rightarrow VA+K \equiv VA+A \equiv VA$   | VAK   | MO<br>[ETB/MO+MO+ETB/MO $\rightarrow$ MO]  |
| 13 | VRK  | $S/D+S+D \rightarrow VR + K \equiv V + A \equiv VA$  | VRK   | ETB<br>[ETB/MO+ETB+ETB/MO $\rightarrow$ ETB]   |
| 14 | ARK  | $D+S+D \rightarrow D+S \rightarrow AR+A \equiv AR \equiv VA$   | ARK   | ETB*<br>[MO+ETB+ETB/MO $\rightarrow$ ETB]  |
| 15 | VARK | $S/D+D+S+D \rightarrow S/D+D+S \rightarrow V+A+R+A \equiv VAR \rightarrow VA$                        | VARK  | ETB*<br>[ETB/MO+MO+ETB+ETB/MO $\rightarrow$ ETB]   |

\* MO has the priority over ETB, because a user needs to click on an object before dragging it. So when it comes to choosing between MO or ETB, the option would be ETB. The same goes to MO+ETB case, as princplely, MO could be counted as ETB and then dragging process, so:

$$MO + ETB \equiv (MO/ETB) + ETB \equiv (ETB) + ETB \equiv ETB.$$

|   | PC $\rightarrow$ User |                          | User $\rightarrow$ PC |          |
|---|-----------------------|--------------------------|-----------------------|----------|
| 1 | V                     | V+R as long as it        | V                     | ETB/MO   |
| 2 | A                     | A (plus R as link and V) | A                     | MO       |
| 3 | R                     | R+V ( $\equiv$ V+R)      | W (R)                 | ETB      |
| 4 | K                     | A                        | K                     | MO / ETB |



|    |      |   |      |     |
|----|------|---|------|-----|
| 5  | VA   | VA (video + audio commentary)   | VA   | MO  |
| 6  | VR   | Text with picture (R + Static V)  | VR   | ETB |
| 7  | VK   | V+K $\equiv$ V+A $\equiv$ VA,<br>Physical interaction   | VK   | ETB |
| 8  | AR   | D+S $\rightarrow$ A+R $\rightarrow$ A+V<br>$\rightarrow$ D+S/D $\rightarrow$ D+D $\rightarrow$<br>VA (Static Text with short sentences and pictures + audio commentary) | AR   | ETB |
| 9  | AK   | A+A $\equiv$ A (Link as text R)   | AK   | MO  |
| 10 | RK   | R+K $\equiv$ R+A $\equiv$ RA $\equiv$ AR<br>R+K $\equiv$ R+A $\equiv$ RA $\equiv$ AR $\rightarrow$ VA (but with static short sentences)                                 | RK   | ETB |
| 11 | VAR  | V+A+R $\equiv$ V+A $\equiv$ VA,<br>Static short sentences of Text would act as pictures, Text with pictures + Audio commentary  | VAR  | ETB |
| 12 | VAK  | VA+K $\equiv$ VA+A $\equiv$ VA<br>(Dynamic pictures/video + audio commentary)   | VAK  | MO  |
| 13 | VRK  | VR + K $\equiv$ V + A $\equiv$ VA,<br>Static short sentences of R would act as V + Audio commentary   | VRK  | ETB |
| 14 | ARK  | AR+A $\equiv$ AR $\equiv$ VA<br>(Static short sentences with audio commentary)  | ARK  | ETB |
| 15 | VARK | V+A+R+A $\equiv$ VAR $\rightarrow$ VA<br>(Static short sentences + studio commentary)   | VARK | ETB |

As “K” means:

- Changes in Relationship (such as MO)
- Changes on the number of objects (Writing  $\equiv$  adding characters), but not change on Relationship

| VARK-based Analysis |                  |           |       | ARK-based switchboard |    |    |   |              |
|---------------------|------------------|-----------|-------|-----------------------|----|----|---|--------------|
| VARK category       | Pc → User        | User → PC | Notes | A                     | RT | RS | K | ARK category |
| V                   | R <sub>SP</sub>  | ETB       |       | 0                     | 0  | 1  | 1 | KRS          |
| A                   | AR <sub>DP</sub> | MO        |       | 1                     | 0  | 0  | 1 | AKRD         |
| R                   | R <sub>SP</sub>  | ETB       |       | 0                     | 0  | 1  | 1 | KRS          |
| K                   | AR <sub>SP</sub> | ETB       |       | 1                     | 0  | 1  | 1 | AKRS         |
| VA                  | AR <sub>DP</sub> | MO        |       | 1                     | 0  | 0  | 1 | AKRD         |
| VR                  | R <sub>SP</sub>  | ETB       |       | 0                     | 0  | 1  | 1 | KRS          |
| VK                  | AR <sub>DP</sub> | ETB       |       | 1                     | 0  | 0  | 1 | AKRD         |
| AR                  | AR <sub>ST</sub> | ETB       |       | 1                     | 1  | 1  | 1 | AKRS         |
| AK                  | AR <sub>SP</sub> | MO/ETB    | *     | 1                     | 0  | 0  | 1 | AKRD         |
| RK                  | AR <sub>ST</sub> | ETB       |       | 1                     | 1  | 1  | 1 | AKRS         |
| VAR                 | AR <sub>DT</sub> | ETB       |       | 1                     | 1  | 0  | 1 | AKRD         |
| VAK                 | AR <sub>DP</sub> | MO        |       | 1                     | 0  | 0  | 1 | AKRD         |
| VRK                 | AR <sub>DP</sub> | ETB       |       | 1                     | 0  | 0  | 1 | AKRD         |
| ARK                 | AR <sub>ST</sub> | ETB       |       | 1                     | 1  | 1  | 1 | AKRS         |
| VARK                | AR <sub>DT</sub> | ETB       |       | 1                     | 1  | 0  | 1 | AKRD         |
|                     |                  |           |       |                       |    |    |   |              |

That means the second and the third group could fall into two main factors. Input and Output tools in the interaction between human and computer; and either from computer perspective or otherwise.

Let's continue on the base of above categorisation and look at them from learner's perspective.

So, the possible outcome would be, for:

Compatible format of Learning Contents – Input – would be: V, A, R (not W), VA, VR (not VW), AR (not AW), VAR (not VAW)

Compatible format of Practice and Assess – Input – would be: V, A, R (not W), VA, VR (not VW), AR (not AW), VAR (not VAW)

Compatible formats of Practice and Assess – Output – would be: K, WK (not RK)

As above Content Objects (CO) should be presented in one package, it is necessary to find out its availability and its use; for example ways of availability and its usefulness would be as following: 1, 2, 3, ...

Thus:

Learning Content (LC) related contexts can't have for example just animation, or a video streaming without a label or audio commentary. So, it clarifies the main need to have a combination of possible DAs (Digital Assets).

LC: VA, VR, AR, VAR

and the same goes to PC (Practice Contents) and AC (Assess Contents):

PC – input: VA, VR, AR, VAR

AC – input: VA, VR, AR, VAR

PC – output: WK

AC – output: WK

Above analysis has identified the best methods towards the best possible combination on creating Learning contents (and it goes to PC and AC, too).

That means, while creating digital assets, they should be linked with their related format for the production phase of content development. Relationship between individual DAs are as follows:

Input:

V => A, R, AR

A => R, V, VR

R => V, A, VA

Output:

W => K

K => W

These could be done as described below:

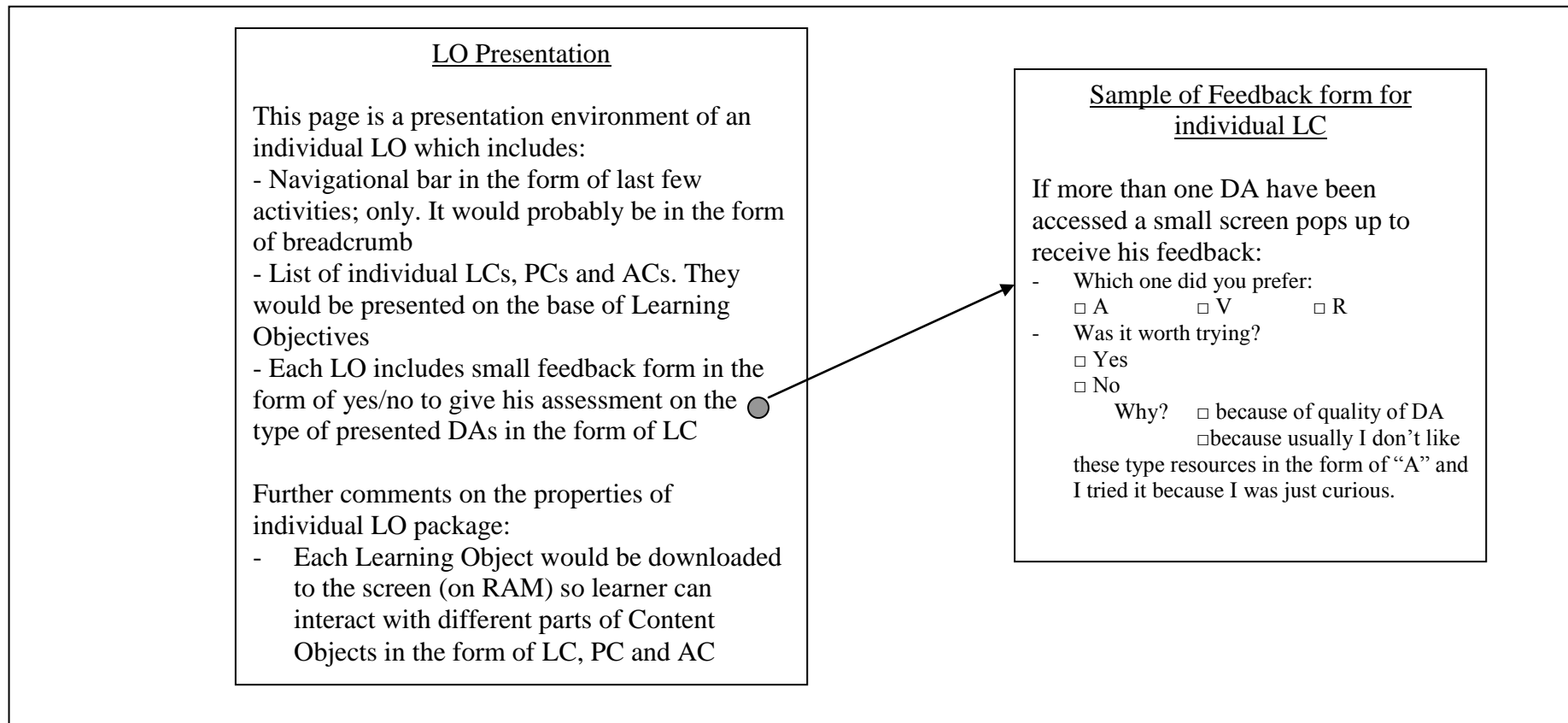
- V => A: Any picture, or animation must include an audio DA
- V => R: Any picture, or animation must include a piece of text (DA) such as a caption
- V => AR: Any picture, or animation must include a piece of text (DA) such as a caption and audio (ex. audio effect, presenter, story teller, ...)
- A => R: Any audio DA must include a piece of text, such as a label or caption
- A => V: Any audio DA must include a picture or animation
- A => VR: Any audio DA must include a visual and textual DA
- R => V: Any piece of text must include a visual DA
- R => A: Any piece of text must include an audio DA
- R => VA: Any piece of text must include a visual and audio DA
- W => K: Any piece of text must be accepted Kinaesthetically, and it is mostly via keyboard
- K => W: Any kinaesthetic activity must be accepted via keyboard in the form of text entry
- K: Any individual kinaesthetic type of activity must be via a mouse and to be used on moving visual objects on the screen. However, this format must be supported by a visual or textual type of DA. \*

*\* this topic needs some further study as it is a complicated matter.*

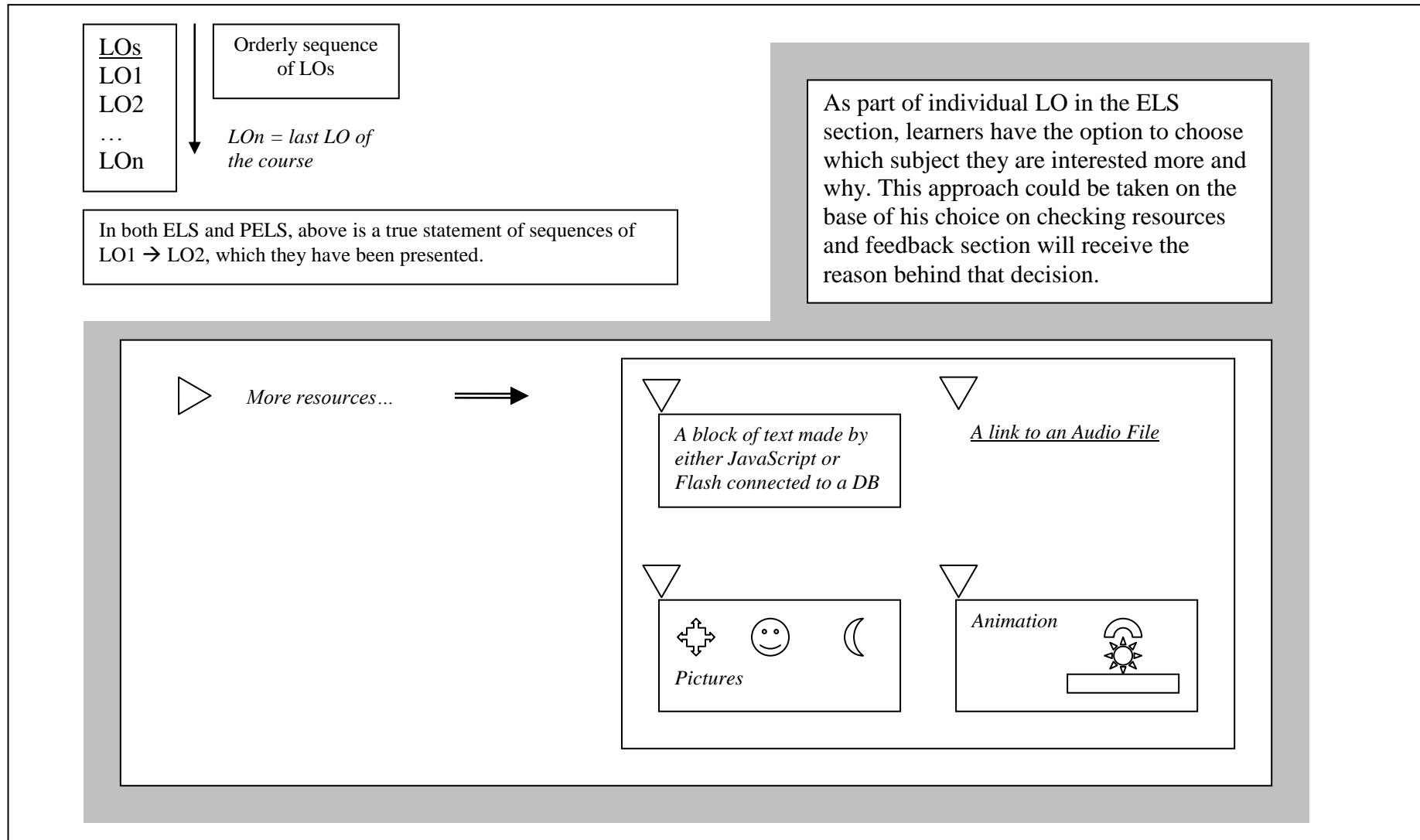
Regarding individually made K type of DA, as mentioned earlier, it must relate to other DAs. However, there is a need arises at the time of developing phase, which means, while a DAk is under development, it should be mentioned what other type of DAs would be involved for the next step of development and that is CO phase.

## Appendix 6 Draft Proposal of user interface while learner navigating through contents materials

### Appendix B: Draft Proposal of user interface while learner navigating through contents materials



## **Appendix 7    Content material presenter and activity tracking system**



A structure for the story:

Components of the story:

Knowledge [Knowledge, Knowledge Transference, Knowledge Management,  
Strategic Knowledge]

Learning

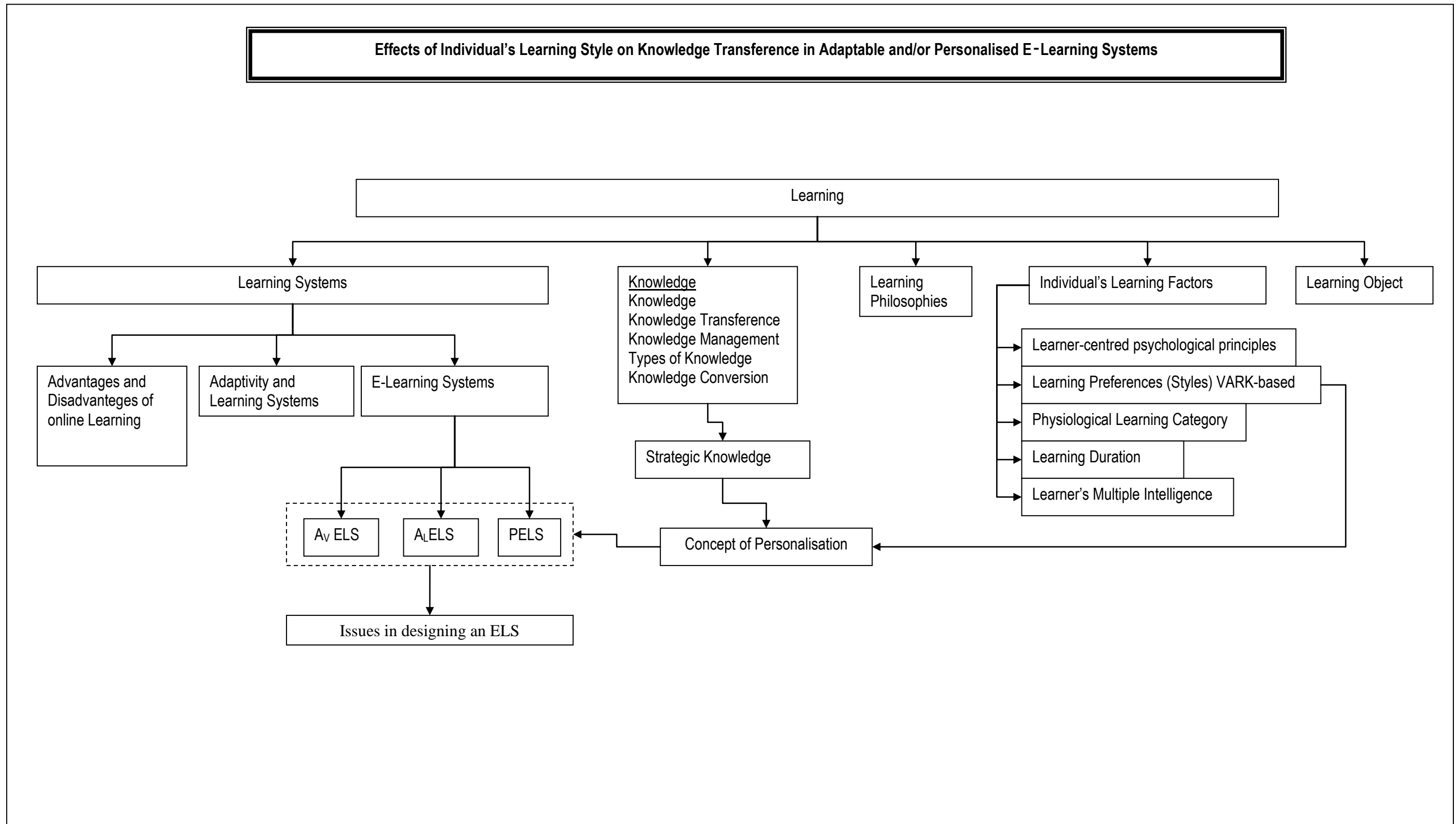
    Learning Systems

    Learning Philosophies

    Learning Styles

    Learning Duration

    Learning





## **Appendix 8 Existing Adaptive systems in Nature**

By referring to above discussions on the necessity of having an Adaptive-Adaptable-Personalised ELS, it is necessary to know that the order is the key factor for a process to be adaptable or adaptive. Whatever, the case, the order should be applied to a fuzzy system, so to get an organised system. As even if the system itself was compliant by the main objective of that process, it would only be a matter of bending the process towards those main objectives of the process. Furthermore, researchers have found that main issue on having an objective and purposeful order on any fuzzy system is in its first kick start, at some point; whether or not this has been issued internally or externally, having a start towards a self-organising system is necessary (Heylighen, F. 2003). This initiative is the main idea behind having an adaptive and/or an adaptable system which will be pursued by putting that kick start of initiating the system with creating a learner's learning style in the system.

Following are detailed descriptions on seven samples of adaptive systems in nature:

**Thermodynamics and the law of Entropy:** Thermodynamics (which is occasionally considered as both a thermodynamic system and its environment) studies process of heat flow within an environment. That environment often contains one or more idealized heat reservoirs – heat sources with infinite heat capacity enabling them to give up or absorb heat without changing their temperature; for example, an ocean or other large body of water approximates a heat reservoir. In general, a thermodynamic system is defined by its temperature, volume, pressure, and chemical composition. A system is in equilibrium when these variables have the same value at all points.

### *The Second Law of Thermodynamics*

The second law of thermodynamics is about a cyclic process which is one that returns the system (and not the environment), to its original state; a closed cycle consisting of two isothermal and two adiabatic transformations. During the Carnot cycle occurring in the operation of a heat engine, a definite quantity of heat is absorbed from a reservoir at high temperature; part of this heat is converted into useful work, but the balance is expelled into a low-temperature reservoir and thus “wasted.” The second law is expressed mathematically in terms of the concept of entropy. *In all real physical processes entropy increases; in ideal reversible processes entropy remains constant. Thus, in the Carnot cycle, which is reversible, there is no change in the total entropy.*

Comparable to the second law of thermodynamics which is about taking the system on a closed cycle and returning an off-balanced system to its original state, would be an adaptive process as the entropy led the process to make the balance between environment’s molecules and its container (Encyclopedia, 2007).

**Conclusion 1:** Any cyclic process happens without any external coordinator to make the balance between environment’s molecules; in fact, the process occurs through an adaptation process on the base of entropy.

**Crystallisation:** Crystallisation indicates creation of a structured and organised symmetric pattern of dense matter in a solution from a randomly moving molecules round each other (the free dictionary, 2007).

**Conclusion 2:** The process of creation of such structure occurs with the adaptation process between molecules of the liquid.

**Magnetization:** Magnetization is the process of making a substance temporarily or permanently magnetic with the insertion of the substance through a magnetic field (Figure 68). Spontaneous magnetization is the term used to describe the appearance of an ordered spin state (magnetization) at zero applied magnetic field in a ferromagnetic or ferrimagnetic material below a critical point called the Curie temperature. (Answers-Magnetization, 2007).

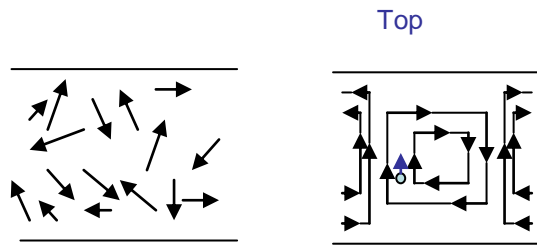


**Figure 68: Magnetisation, Before and After views**

**Conclusion 3:** The process of the orderly arranged spin of a substance to be inclined by an external magnetic field or within Curie temperature is an adaptation process.

**Rayleigh-Benard Convection Law:** Convection of a fluid heated from below, characterized by a regular array of usually hexagonal cells (Answers-BenardConvectionLaw, 2007).

By heating a layer of fluid from below, the density at the bottom layer becomes lighter than at the top thus the system is bottom heavy but does not necessarily undergoes convective motion since viscosity and thermal diffusivity of the fluid try to prevent the convective motion (Figure 69). Now, if the fluid is heated sufficiently large enough, then only the top heavy state becomes unstable and convective motion ensues. So, in fact the fluid tries to adapt to this new heated environment (Ghorai, S., 2003).



**Figure 69: Rayleigh-Benard Convection Law**

**Conclusion 4:** The process of moving molecules within a liquid is an adapted process as there is no external coordinator to follow up and direct the movement of individual molecules.

**Living Organisms – Plant:** The most obvious example of such dissipative systems are living organisms.

- Plants and animals take in energy and matter in a low entropy form as light or food.
- They export it back in a high entropy form, as waste products.
- This allows them to reduce their internal entropy.
- Thus counteracting the degradation implied by the second law.

**Conclusion 5:** This process is also an example of a form of an adaptation by reducing entropy of a system.

**Tumour:** Another sample to the adaptation concept would be tumour, although it is better known as an abnormality growth of tissue resulting from uncontrolled, progressive multiplication of cells. Malignant tumours are called cancer. Cancer has

the potential to invade and destroy neighbouring tissues and create metastases. Benign tumours do not invade neighbouring tissues and do not seed metastases, but may locally grow to great size. They usually do not return after surgical removal.

**Conclusion 6:** In a conclusion point, if tumour cell wants to live with other tissues, it has to adapt to new situation and then can live longer.

**Hybridisation:** Literary hybridisation means, “Producing offspring from parents of different stock.” Hybridisation is used extensively in agriculture where new forms of hardy and disease-resistant plants are produced commercially (Answers-Hybridization, 2007). In another words, hybridisation is crossbreeding two species to create a plant with some characteristics of each parent (Mimi, 2007).

**Conclusion 7:** The added or newly created plant needs adaptation for its living in a new environment.

**Conclusion of this section (Adaptive Systems in Nature):** By reviewing the above systems, we can consider the fact that the process of adaptation is a kind of process that possesses itself in, with a kind of retrying different methods of communications to new conditions by trying varieties of small packages of sticky fork of structured sub-systems, to be able to gain the ability of change of the new environment to its built structure. This method of changing the new environment to a form which is acceptable to its original development system is known as self-organisation method.

## **Appendix 9 Knowledge, Knowledge Management and Knowledge Transferring Systems**

### 9.1 Summary

In this section (i) Knowledge, (ii) Needs for Knowledge Management Systems and (iii) Knowledge Transferring Systems are studied. The discussion will also debate findings about the relationship between both (a) Individual's learning styles and (b) knowledge transfer mechanism, based on the concept of strategic-knowledge.

#### **9.1.1 Knowledge and Knowledge Management**

In this section knowledge and the necessity for managing its entities will be discussed. Concepts of knowledge, knowledge management, knowledge types and converting them into different forms will be studied.

##### ***9.1.1.1 Knowledge***

The definition of knowledge comes with the making sense of existing collections of information in the form of understanding their purposes, use and the process of creating new information. The pattern in which information is created, processed, stored and re-created again makes the knowledge about something (Nonaka, 1991; Nonaka and Takeuchi, 1995; Haberberg, A. & Rieple, A., 2008, pg. 408-409). Knowledge is the fact or condition of knowing "about" or understanding exiting fact; and knowing "how to" or the "process" of creating a new fact (Knowledge, 2009). Knowledge is the building block of wisdom which includes data, information and the process of converting data into information. Knowledge is the raw facts data formed

into information with guided actions based upon insight and experience (Morgan G., 2008). The argument of whether this new information could be explained and used or not, and will be explained further in this study.

#### ***9.1.1.2 Knowledge Management***

Knowledge like any other entities would require management to apply it in day to day life. It requires creating an environment in which the information could be passed along to the right person, at the right time, and in a suitable format with insights and experiences. A set of processes that creates, captures, stores, maintains and disseminates a firm's knowledge (Laudon, and Laudon, 2007-pg., 434). As Nonaka (Nonaka, 1991; Nonaka and Takeuchi, 1995; and O'Brien and Marakas, 1999 – pg. 62) originally defined “knowledge management” and its use in organisations, as “a mechanism that creates new techniques, technologies, systems and rewards for getting employees to share what they know and to make better use of accumulated workplace and enterprise knowledge. In that way, employees of a company are leveraging knowledge as they do their jobs. In that view the organisational structure for managing those components is known as the knowledge management system.”

#### ***9.1.1.3 Types of Knowledge***

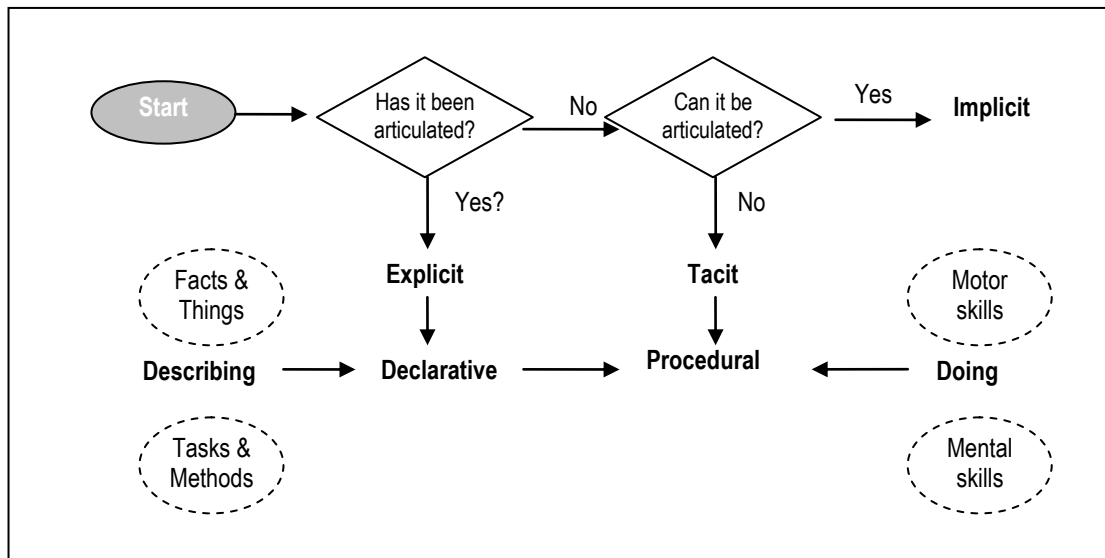
The main objective of the knowledge management is the understanding of different types of knowledge which have different characteristics. In other words, by comparing the body of knowledge to a building structure, it would have a process which requires an organisation. In that respect, to understand and learn about its components and finding ways to improve its efficiency, knowledge management opens up a road map for this purpose. As the cloud of the body of knowledge has an

organisational structure, by further understanding of its different types, awareness on its characteristics could be added to, and as such its organisational structure could perform more efficiently and be the source of its own further development. Changes in categorisation of knowledge have been continuously shaping the process of creating different methods of interaction. The development of these new forms of knowledge categorisation has acted as the focal point of epistemology. (Polanyi, M., 1962; Polanyi, M., 1966; Nelson & Winter, 1982; Baumard, 1999; Nickols, F. W., 2000; Grant R. M., 2008)

The core factor of these differences is *knowing-how* and *knowing-about*. Basically knowing-how is known as *tacit knowledge*, which is something that can't be articulated. The knowledge that can easily be expressed and articulated such as factual knowledge is known as *explicit knowledge* (knowing-about). There are two other types of knowledge which are concerns of this research. These are *Implicit Knowledge* and *Strategic Knowledge*. If knowledge has not been articulated but can be, it would be called "*implicit knowledge*". *Strategic Knowledge* is about "know-when" and "know-why"(Polanyi, M., 1962, Grant R. M., 2008).

Nickols (Nickols, F. W. (2000)) a cognitive psychologist has proposed a view on the categorisation of Strategic knowledge by counting it as a subset of other types of knowledge. On the contrary, the view of considering an individual's decision making style as a factor in defining implicit knowledge would give the right to this type of knowledge to be a separate category in itself. This is a major key factor in the evolving process of personalisation of e-learning systems.





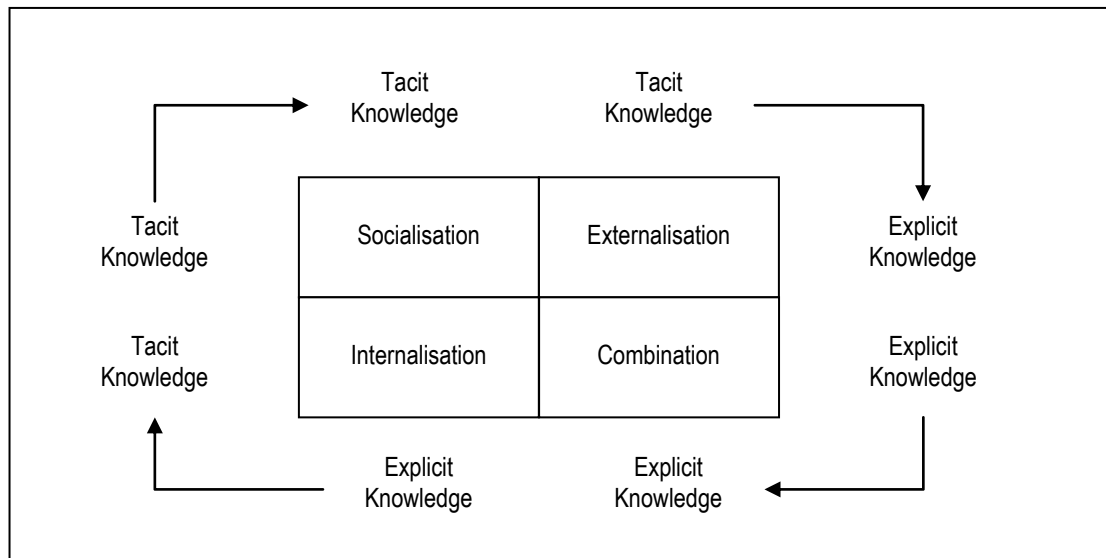
**Figure 70: A framework for thinking About the Knowledge in Knowledge Management. Adopted from: Nickols 2000**

As mentioned earlier, Nickols (Nickols, F. W. (2000)) proposed that “Strategic Knowledge should be counted as a subset of declarative knowledge (figure 1), its definition (*know-how and know-why*) would permit the strategic knowledge to be classified into a separate category based on its description (*know-how and know-why*) and not on *how-to* views. This separation of a type of knowledge known as “Strategic Knowledge” would prepare a ground work towards the involvement of individual’s decision-making-style into categorisation of knowledge. The involvement of individual’s learning style with the process of (i) drawing the boundary between tacit and implicit knowledge and then (ii) converting implicit knowledge into explicit knowledge would be a strategic approach towards manipulating this type of knowledge through an information system. These concepts and processes will be explained further in following sections.

#### **9.1.1.4 Knowledge Management and Knowledge Conversion**

Cognitivist researcher Nonaka (Nonaka et al. 1996) proposed four different types of knowledge conversion processes. They are: a) Socialisation, b) Externalization, c) Combination, and d) Internalization processes. These knowledge processes are needed to be able to employ a suitable format of tacit or explicit types of knowledge, so the newly formed converted knowledge is capable of flowing through different medium (types) of knowledge.

*Process of Socialisation* is meant to be used to transfer the tacit knowledge as complete as possible to lessen the error involved in the process through the transferring-medium. Researchers have confirmed that it is not an error-free process (and as such, it is not possible as a completed process) to transfer tacit knowledge through a Knowledge Management System (KMS) (Nonaka, I. and Takeuchi, H. 1995; Tseng, S. 2008). This approach towards knowledge transferring puts any type of knowledge management information system into a part-solution-provider where the system would be able to deliver the knowledge in purpose with the support of a knowledge-transfer application on the base of knowledge conversion mechanism (Nonaka's spiral of knowledge creation – Nonaka, 1993). As such, a knowledge management system attempts to compensate for the error involved on the process of tacit-to-tacit knowledge transfer (in the form of learning) by taking a type of knowledge through a series of spiral cycles (Figure 71) known as knowledge conversion (Nonaka and Takeuchi, 1995).



**Figure 71: Knowledge conversion. Source: Adopted from Nonaka & Takeuchi (1995).**

Based on the spiral model of knowledge conversion proposed by Nonaka and Takeuchi (1995), Figure 71, there is an indication of a solution to the issue of error compensation while knowledge of type tacit-tacit transfers. As presented on the diagram (Figure 71), (a) in a social mode the tacit-to-tacit conversion process can be demonstrated in the form of sharing ideas, presenting technical skills in a team-based activity and discussions based on a mental model through interaction between class members or a group going through a brainstorming session. (b) Externalisation mode is a form of tacit to explicit knowledge conversion which occurs when explicit knowledge is made of tacit knowledge in the form of descriptions, comparisons, hypotheses and models. As Nonaka and Takeuchi, (Nonaka & Takeuchi, 1995, 1996) have clearly defined the tacit to explicit knowledge conversion processes as an attempt to conceptualise images and then their expression in a language, where in this form of knowledge conversion, information is mainly used to compile different analogies and metaphors for the creation of new knowledge. (c) Combination

type of knowledge conversion is the outcome of combining or elaborating existing documentations in any session or class to produce new knowledge and it is known as the process of explicit to explicit knowledge conversion. The outcome of activities of any learning environment aims at combination form of knowledge conversion. (Choo, 1998). (d) By internalization mode, Nonaka and Takeuchi (1995) defined the mode as the process of conversion of explicit to tacit type of knowledge. The process of sharing information will be in the form of converting explicit knowledge into tacit actions, and could be categorised as another form of learning by doing.

Alkhaldi, F.M., & Olaimat, M. (2006) have indicated that the main point behind knowledge conversion within a learning environment is that the conversion does not happen within the individual teacher or learner but between individuals involved within that learning environment. The process of knowledge conversion from one type to another and between tacit to explicit forms would indicate the process of continuous learning. In another word, the knowledge conversion requires interaction between both tacit and explicit knowledge and between individuals and groups involved in the learning environment.

To conclude, different modes of the knowledge conversion process require four modes of interaction between tacit and explicit knowledge, as such it starts from socialization then to externalisation, to combination, to internalization, then again to socialization and so on. At each stage of conversion, different kinds of knowledge are being created, over and over

again. All the way through current discussion, while the stages of creation of different forms of knowledge were explored, the main focus of all those distinctions was about the conversion of tacit and explicit knowledge. It should be noted that the cycle or process of SECI model (Socialisation, Externalisation, Combination and Internalisation) is a constructivist approach towards knowledge conversion (Meehan, 1999). Following section discusses the relationship between types of knowledge and the process of knowledge conversion (SECI process) to the teacher- or learner-centred e-learning systems.

**9.1.2 An approach on the delivery of the Tacit knowledge by means of Teacher- and/or Learner-centred systems**

The diagram in Figure 71 (*Knowledge conversion*) (Nonaka, 1995; Nonaka et al. 1996) shows the main difference between (i) teaching systems with face-to-face sessions in traditional classes and (ii) a learning system in its non-tacit delivery form of knowledge. This model supports (confirms) the necessity of having the method of spiral cycles using a learning system for this purpose (tacit-to-tacit knowledge delivery); by taking the concept through the following process:

The main purpose of teaching in a class is to delivery the tacit type of knowledge to a student. As this type of knowledge can't be delivered in a perfect form, the error caused on its method of delivery should be compensated via taking a spiral cycle of converting knowledge into different formats. Thus, a teacher (tutor) documents a concept (knowledge to be taught) and so converts that knowledge into a form of articulated explicit knowledge through an *externalisation process*. A content management system (CMS) whether to be in the form of an online content provider or the traditional face-to-face classes delivers the articulated knowledge in the form of

explicit knowledge through a *combination process*. Then it would be the responsibility of the learner to gain and understand as much as s/he could via the *process of internalisation* to transfer the explicit knowledge into tacit knowledge. As shown above, knowledge conversion must happen between individuals and not in an individual separately.

### ***9.1.2.1 Knowledge Transferring Systems (Teacher-centred, Learner-centred and Knowledge Management Systems)***

The main difference between teacher- and learner-centred systems is that each one interacts with the articulated knowledge. The process of determining this method of interaction could ease the process of defining the boundary of implicit and tacit knowledge.

Teacher-centred systems require face-to-face sessions for their method of delivery of knowledge; which requires a *socialisation process* as a procedural method of sharing tacit knowledge. On the other hand because tacit knowledge cannot be articulated then the amount of shared knowledge through different processes (teacher-centred in comparison to learner-centred systems) would create a completely different form of transferred knowledge. Basically, from a knowledge-transfer-system's point of view:

Traditional Teacher-centred Systems  $\neq$  Learner-centred Systems

The main question here would be how close a learner-centred environment can get to a teacher-centred environment? And is there any involvement of personality of teacher and learner with the knowledge-transferring environment?

Answering this question would require further study on different types of knowledge and their relevancy together.

Following the discussion above (Types of knowledge), teaching environment (medium) is a more controllable environment than a learning environment (from teacher's point of view), because the interaction between teacher and learner involves varieties of variables, such as reading student's body language (e.g. is the teaching material exciting or boring?) and the mood of both parties involved in the class are considered factors in the medium of knowledge-transfer. Moreover, in a learning environment, the learner him/her self is in control and the procedure which has been put in place by an instructional designer should be well designed and sufficiently comprehensible to give proper direction to the learner for his/her learning activities.

Despite the fact that content materials between both teacher- and learner-centred methods could be the same, in the hope of an equivalent outcome, because of the presence of tacit knowledge in teaching materials, the outcome of both methods for the purpose of delivery of knowledge will never be the same (as knowledge in the form of tacit cannot be articulated), thus:

Outcome of Learner-centred methods  $\neq$  Outcome of Teacher-centred methods

To find a solution for the fact above and how to use, and integrate information technology in the form of a knowledge management system, researchers continuously are expanding the field in the relation between knowledge management systems within the educational framework.

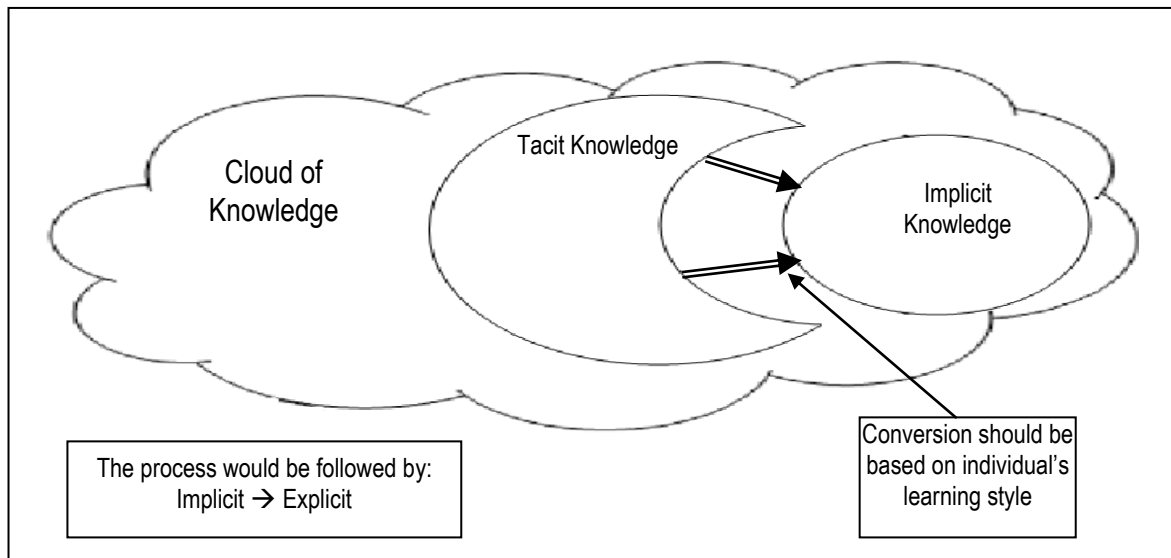
Knowledge Management Systems can support a teaching and/or learning environment and be used in the form of a learning system (Alavi, M. and Leidner D. 2001, Raman

M. et al. 2005, Hurley et al. 2005). This support would be in the form of knowledge transfer. The answer to the question of whether this system can be personalised or not, will be discussed further in the following sections.

### ***9.1.2.2 Getting a learner-centred learning environment closer to a teacher-centred one***

In order to devise a set of business rules for either teacher- or learner-centred environments it is necessary to determine those components (components or sub-system of the knowledge creator, knowledge transfer environment and the recipients for that knowledge) and then the boundary between them. As such, that step would initiate the design and development phases of a semi-tacit-based knowledge management system. On the other hand, by further studying shared values and identifying differences between the personalisation of teacher- and learner-centred environments, this approach would provide evidence in areas which could be articulated, specifically based on the philosophy of the learner-centred environment and not the teacher-centred one. The study of identified and articulated knowledge would formulate the understanding of key factors involved in defining the boundary of the area of implicit knowledge which would support this study in finding relations between individual's thinking and decision making methods (processes) with the existing knowledge in hand (in the form of tacit knowledge). In another word, different individuals are having different learning styles, which would be a determinant factor of defining those set of business rules in learning management systems which will be investigate and defined later on.



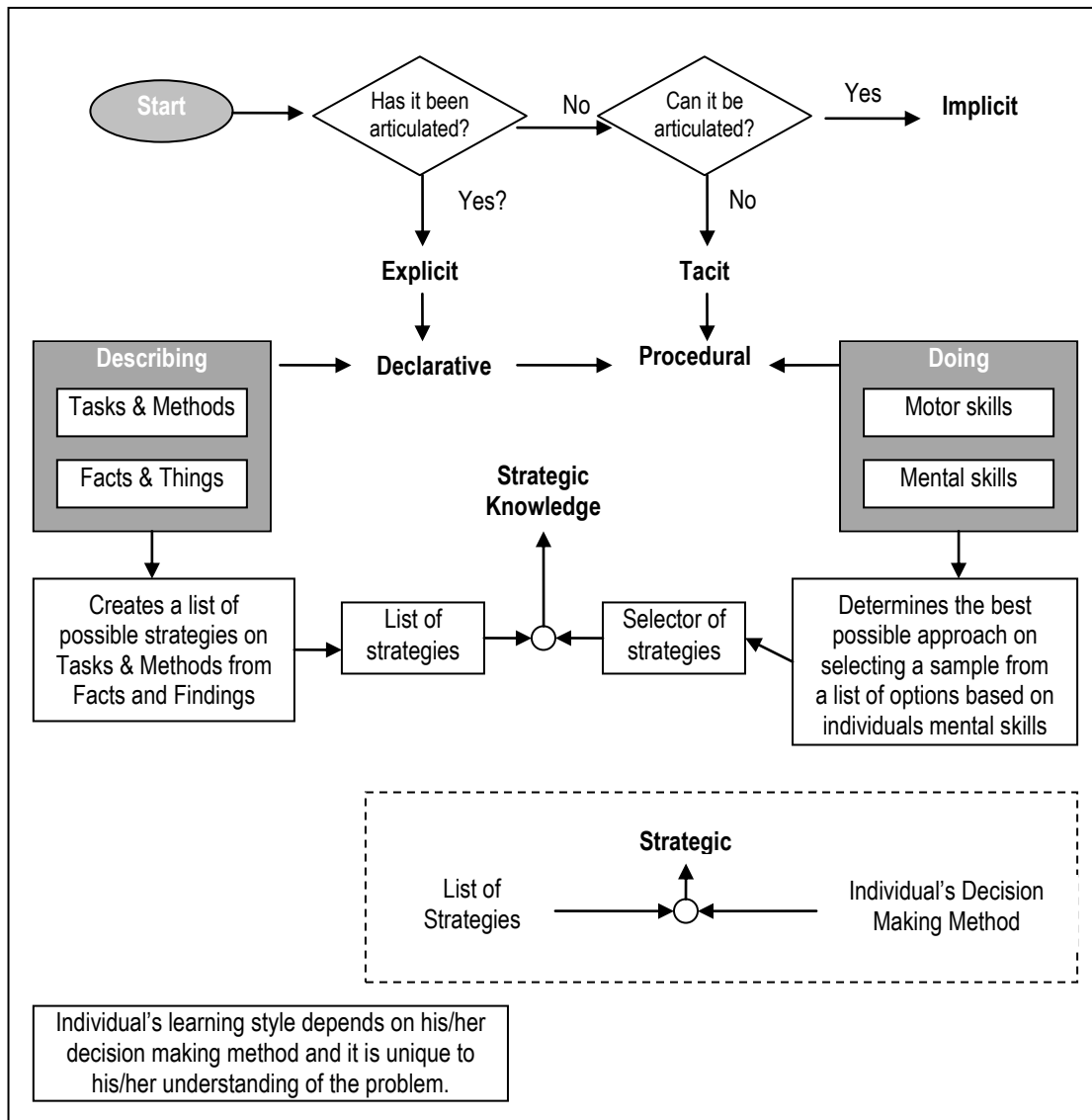


**Figure 72: Categorisation of knowledge and a diagram on the conversion of tacit to implicit knowledge**

Figure 72 presents a basic idea behind the form of converting the tacit into implicit knowledge so to have a form of a usable knowledge on a topic. As such the principles of drawing those functions (conversion of tacit into implicit knowledge) should be based on the individual's learning style. This is the core reasoning behind design and development of any Personalisation of ELSs.

### **9.1.3 Relationship between Learning Styles and Strategic Knowledge**

Learning and understanding of the relationship between an individual's learning style (which is mainly structured on the bases of an individual's decision making process) and strategic knowledge requires further study on the concept of learning styles. As a learning style would determine one's approach towards interacting with an environment for the purpose of either gaining knowledge or doing a task, this concept would indicate the following relationship as shown in Figure 73.



**Figure 73: Illustration of the process of personalisation of strategic knowledge creation; updating the Nickols (Nickols, 2000) framework on types of knowledge.**

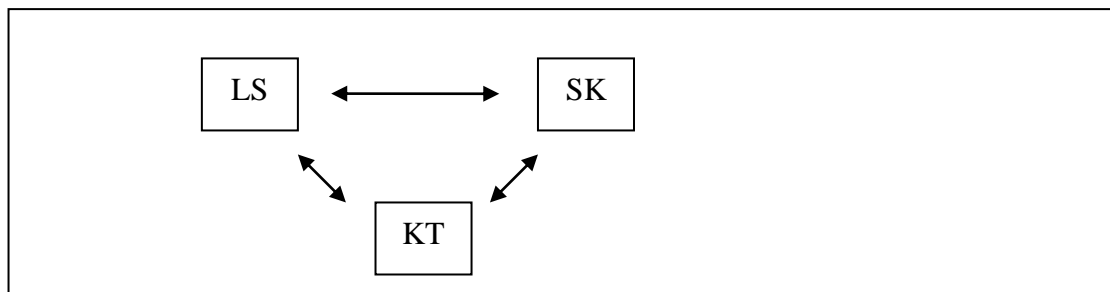
Figure 73 proposes an illustration of the process of converting declarative into procedural knowledge in the form of tacit knowledge. It clearly shows the process of personalisation of strategic knowledge creation, updating the Nickols framework (Nickols, 2000) for the procedural approach on the involvement of an individual's decision making method for selecting a strategy. Furthermore, the process could be reversed if the purpose of conversion is to create implicit knowledge out of tacit knowledge, so as to define the boundary of this conversion. This conversion takes into

account that tacit knowledge can not be articulated. As it is mentioned above, the personalised strategic knowledge draws a framework for the creation and selection of strategies which are based on individual's decision making style when it comes to dealing with learning new subject (gaining new knowledge), or in another word the strategic approach on the selection of a specific strategy is based on individual's learning style.

Decisions on “how to describe knowledge on a topic”, “when to describe it”, and “finding reasons on methods of describing those facts” depend on an individual's decision making style. In that view the strategic knowledge would be a determinant factor in clarifying the relationship between Learning Style, Strategic Knowledge (SK) and Knowledge Transferring (KT):

- KT is the reason for the need of an ELS.
- LS is the determinant factor on selecting SK
- SK is about “know-when” and “Know-why” under the category of “know-about”

Figure 74 illustrates the relationship between all three main factors involved in defining the personalisation of e-learning systems.

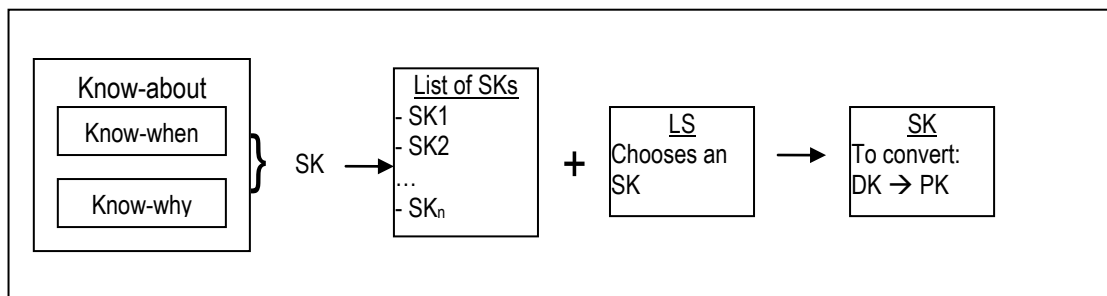


**Figure 74: Illustrating the relationship between Knowledge Transferring (KT), Strategic Knowledge (SK) and individual's Learning Style (LS)**

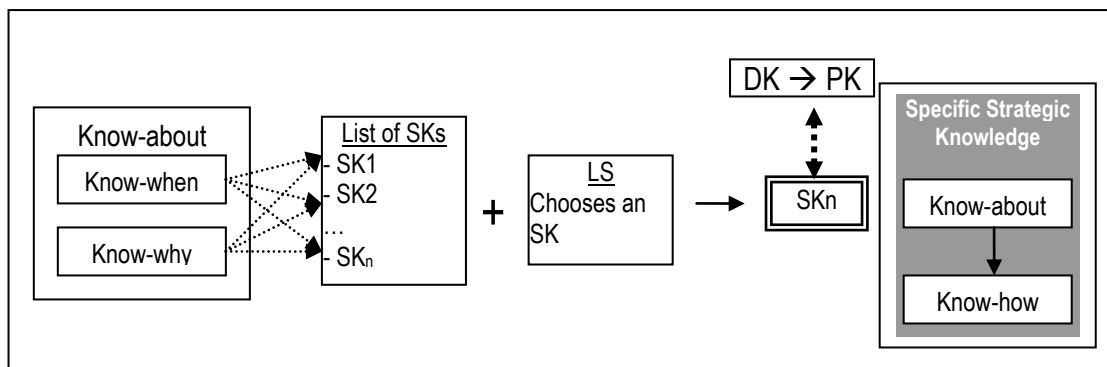
Details of how relationships between objects in Figure 74 are related have been described in Figure 75 and Figure 76 in more detail.

SK creates a list of options on “know-about” then LS is the factor for selecting the specific SK, which would be the determining factor in continuing (or moving) from declarative knowledge to procedural knowledge.

Thus:



**Figure 75: High level view of the process of creating Procedural Knowledge from Declarative Knowledge.**



**Figure 76: Detailed view of the process of creating Procedural Knowledge from Declarative Knowledge.**

The product of the Figure 75 and Figure 76 (moving contents from the form of the declarative knowledge to procedural knowledge) would be non-articulated knowledge, which has been based on individual’s decision making style. (Anderson, J. R., 1982). A collection of productions is known as Procedural Knowledge. As such, a series of IF-THEN statements would be presented and then individuals would make a selection based on their understanding of the situation in order to make a choice.

This newly configured knowledge is a combination of tacit knowledge with its converted form to existing explicit and/or implicit type of knowledge.

BUT, declarative Knowledge needs an additional piece of knowledge in order to become procedural knowledge (in the form of additional tacit knowledge and so must be converted into explicit knowledge).

Thus:

DK + [something] → PK

Or:

“Declarative Knowledge” with the addition of “Something” would become  
“Procedural Knowledge”

By elaborating further to know more on that [something] it could be said that, when we see something we start to describe and simulate it to a similar shape or concept from the archives in our memory, similar to Polanyi’s example of picking someone’s face out of a crowd.

But the process (in itself know-how) of giving a description or creating a simulation in the memory is tacit knowledge, which can’t be articulated. Despite the fact that there are approaches to finding some implicit knowledge from the process, it should be noted that two people’s approach to obtaining strategic knowledge can’t be the same, as it is tacit knowledge and based on their method of know-how the product of knowledge conversion from declarative to procedural format are not the same.  
(Matzler K. et al. 2008)

Or in another word, an individual's unique decision making method which is key to individual's unique learning style is a determining factor in approaching to a knowledge concept. This individually based unique method establishes a set of roles and guidance when it comes to approaching and directing those concepts. The interaction with those concepts will be guided by a set of roles which are unique to the learner's learning style.

Thus?:

$$LS \propto SK \propto KT$$

“Learning Styles” relates to “Strategic Knowledge” which in turn relates to “Knowledge Transfer”.

#### **9.1.4 Conclusion of this section**

This section attempted to present a new understanding in the relationship between an individual's learning style, strategic knowledge and transferring knowledge. By exploring concepts of knowledge, knowledge management, needs for knowledge management systems, different types of knowledge, converting them into different forms, and knowledge transferring systems have been studied. They are considered as core components of any Learning Management Systems.

The main finding here is that strategic knowledge (SK) has an important role in any knowledge transfer system (KT) that is affected by an individual's learning style (LS). These personal characteristics from individuals' learning style are determined on the base of a personal decision making process which is unique to each person. This analysis determines the main difference between teacher- and learner-centred learning systems.

**Perspectives on Transferring Knowledge**

Knowledge transferring mechanisms (machine) acquires learning systems for its purpose. As mentioned earlier (in section 9.1.1), knowledge in itself does not make any sense and it has to be delivered to another source so to be stored, processed and then able to produce new outcome; learning systems have been used for this purpose. Learning systems as attempted solutions towards transferring tacit knowledge with the support of explicit knowledge through externalisation, combination and internalisation processes mimic a form of a knowledge transferring machine (Appendix 9). This approach has been used in the research because basically, it is not possible to use any kind of machine as a means for the delivery of knowledge in the medium of the socialisation process of the knowledge conversion without error in its transference; although, there have been few attempts made in this regard on transferring the tacit knowledge with the support of systems such as Facebook (Facebook, 2004), Myspace (MySpace, 2003), Hi5 (Hi5, 2003), Twitter (Twitter, 2006) and many other social network service types of websites. All kinds of social networking service sites, attempts to present information on individuals' self-sensing and self-expressing identities which is the fundamental of ecology of tacit knowledge (Ginger, J., 2008). In the light of this argument and understanding of the relationship between the effect of tacit knowledge presents in teaching and learning environments, the following conclusions can be made:

a. Teacher-centred learning environment (pedagogical views)

An environment where a teacher (instructional designer) navigates through utilising tacit knowledge to deliver the required teaching materials in the form of either explicit and/or implicit knowledge.

b. Learner-centred learning environment (andragogical views)

An environment where an instructional designer acquires the best possible method for the delivery of knowledge to work with existing teaching materials in the form of explicit and implicit knowledge; and then it would be the responsibility of the learner to gain as much knowledge as possible as s/he can by navigating through the structured knowledge.

c. Personalised learning environment (Andragogical and Heutagogical views)

An environment which involves and presents an individual's decision making method in the form of a learning style through strategic knowledge in a learning environment.

d. Personalised e-learning system (PELS)

PELS is an environment where the process of finding individual's learning style would be done through an electronically developed system and as such the learner should continue to use the system to gain the required knowledge electronically.

There are advantages to designing and developing a learning environment especially with the help of technology and as it is one of the main objectives of this research that supports the control of a learning environment and updates its teaching materials specially on the process of its production unlike a traditional paper-based teaching environment which would require a tremendous amount of work to update its content materials. Besides, with the support of technology, managing the profile of an individual learner's learning style and relating this to their required learning materials



is much easier compared to the use of teaching classes, which is almost impossible to do so.

Through the evaluation of shared points of views between concepts of (i) an individual's unique decision making process (method) and (ii) individual's unique learning style, it could be argued that a unique approach of the method of articulating knowledge would support the design and development of a unified form of a knowledge-based system. The best form of this type of system is known as personalised e-learning system. This would confirm the compatibility of this outcome based on an individual's understanding of the accessible knowledge in the form of converting tacit knowledge into an implicit and then into explicit types of knowledge. In addition to the above discussion, a learning system (which provides contents in the form of sources of knowledge accessible to the learner), and learner's unique learning style would support an educational mechanism known as personalised learning system. This type of system leads to the design and development of a personalised e-learning system.

$$KT_{TK} \equiv KT_{\text{Learning Systems}} + LS + e$$

Where:

$KT_{TK}$  stands for transferring knowledge of type tacit

$KT_{\text{Learning Systems}}$  stands for learning systems type of knowledge transferring

LS stand for learning styles

$e$  stands for dissipation error or the amount of knowledge which is transformed into other types of messages while senders (instructors) attempts to convert tacit knowledge into explicit knowledge (externalisation process) and learners attempt to convert the explicit knowledge into newly formed and constructed tacit knowledge (internalisation process).

(Knowledge transferring of tacit knowledge is a combined process of knowledge transferring systems based on – with the support of – learning systems which have been designed on individual's learning style)

Or basically to transfer tacit knowledge, a learning system would be required with the consideration of learner's learning style, known as a personalised learning system.

$$\text{ELS} + \text{LS} \equiv \text{Personalised ELS}$$

Above relation is another indication for the relevancy of personalised e-learning systems with individual's learning styles based on strategic knowledge (previous section).

The process of assessing existing research in the field of e-learning systems, drives the continuous growth in the field of learner-based learning-materials-provider (in another word: learner-based content management systems), and has been categorised into three major groups in this study. They are:

- Personalised ELSs (PELS)
- Adaptable ELSs ( $A_L$ ELS)
- Adaptive ELSs ( $A_V$ ELS)
- And combinations of above

Meanwhile, the perspective of knowledge transferring systems requires further exploration of learning philosophies including their approaches on different interpretations of teacher-learner interaction.

## **Appendix 10 Investigation of Existing ELS types**

As mentioned in section 1.5, 2.3 and Appendix 8, the search started with preliminary investigating of existing e-learning systems used by educational institutions in the UK [HERO, 2008]. The main objective of this research was to learn about key factors included on types of e-learning systems. On that principle, websites of all 195 universities and colleges were visited, and gathered data were stored on a database build for this purpose (Figure 77 and Figure 78).

The base of this research has been established on searching through each institution's Web site, their search engines and library's web site on finding right materials; as it is the best medium for institutions to present their ideas and services. In many occasions a link was followed to many other web pages within their related departments and their published web pages. Individuals lecturers and staff web pages, related conferences' reports and many other links have been followed for this reason; so any chance of getting any information related to their services on e-learning systems (not precisely distance learning) and ideas of establishing their system was searched for.

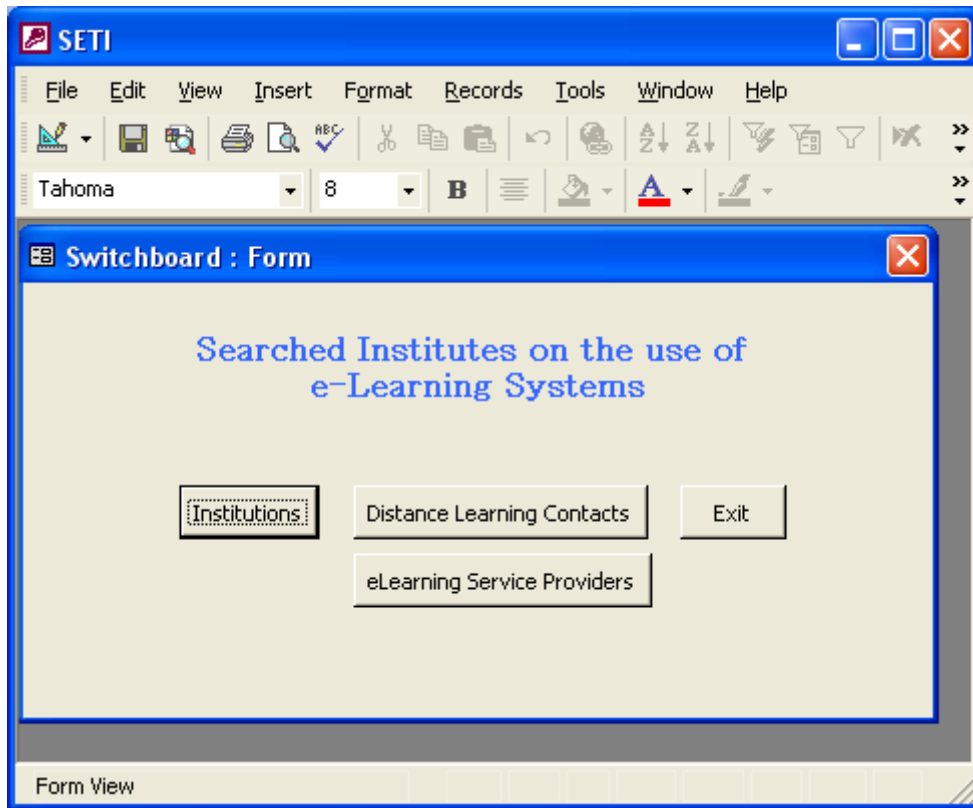
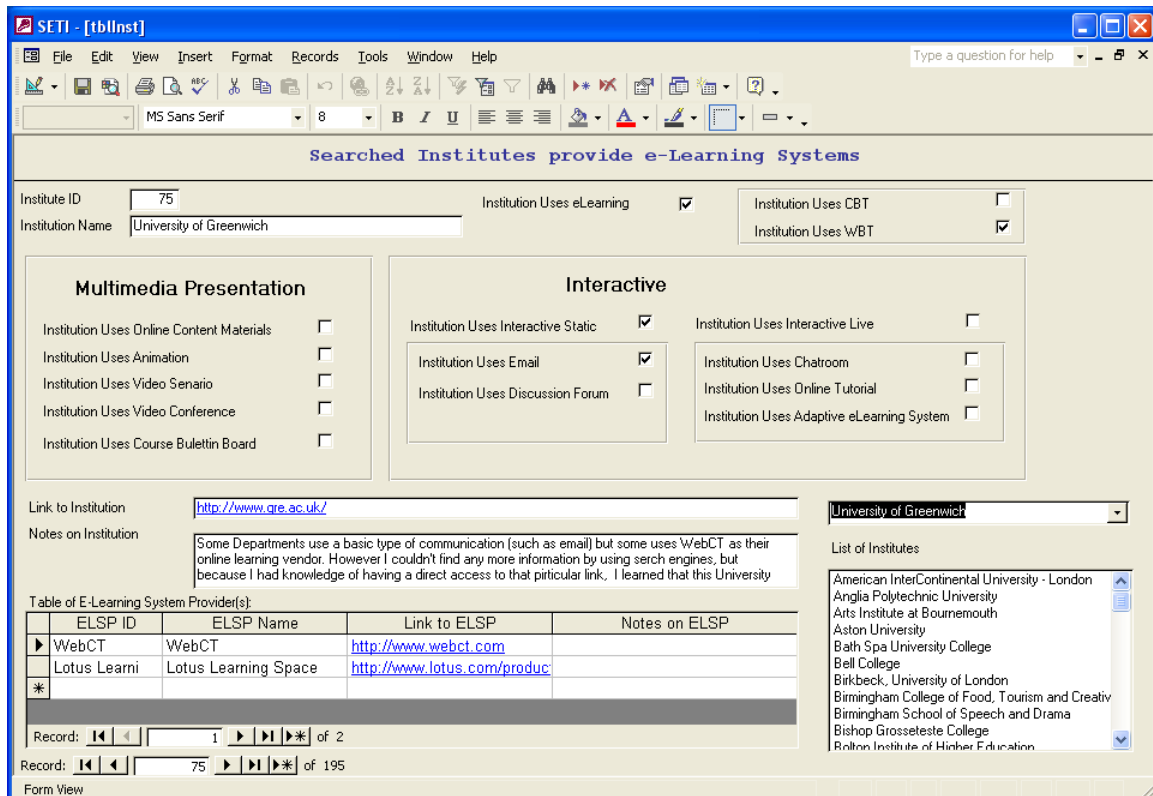


Figure 77: Screen capture of Searched Institutes on the use of e-learning systems' switchboard



**Figure 78: Screen capture of the form used for entering information on individual universities' use of e-learning system**

Outcome of the preliminary analysis of searched data on Universities and higher educational institutions – (gathered in 2004) are presented in Table 59. Data were collected based on the website of individual institutions and whatever tools has been used as the principle means on using e-learning system.

|   | Number of Edu. Institutions | Ratio compared to the total number of Institutions searched for |
|---|-----------------------------|---|
| Total No. of Inst. Under research           | 195                         | 100%  |
| No. of Inst. Uses eLearning Systems *       | 90                          | 46%   |
| No. of Inst Uses particular LMS             | 56                          | 29%   |
| No. of Inst Uses Adaptive eLearning Systems | 0                           | 0%  |
| No. of Users of WebCT                       | 29                          | 15%   |
| No. of Users of BB                          | 16                          | 8%  |

*\* Any electronically based method of technology used for the purpose of communication.*

**Table 59: Findings from data stored on universities use of e-learning systems**

### **Discussion**

As clearly presented on the Table 59, there is no higher educational institution in UK officially uses any type of adaptive e-learning systems as a means of education. This point has given this research a boost on finding out what are reasons behind lack of this type of adaptivity of e-learning environments in education.

Main concern of this research was to identify and analyse existing e-learning systems to learn about types and methods of presenting knowledge to a learner through their applied LMS in their institutions. By modelling those systems and comparing them

with existing developed systems, there could be a good sign of having a new mechanism of knowledge-presenter through an e-learning system.

The outcome of the research was that there were few LMSs such as WebCT or Blackboard, which provided good facility towards Management of Learning environments on line; but on the other hand they needed a skilful instructor to provide content materials, which mostly were static type of teaching content materials [appendix List-Of-ELsSs-and-AIs](the production log).

There were also some other types of e-learning systems have been developed [appendix List-Of-ELsSs-and-AIs] (the production log), which used Artificial Intelligence as their Learning Management Systems. For example, an animation in the form of a tutor presents a subject, as it tries to control the subject (knowledge) presentation through a method of communication normally by asking questions or explaining a subject.

However, within existing LMSs, a learner shows that he learns from the system but in fact he only reads whatever a tutor has provided him through some context material provided on line. There could be some dynamic presentation, too; but still method of presentation itself is not active so to say that the learner would learn from a real and private tutor. The key point here is not to develop a system which would act as a private tutor with few private lessons but the system itself should be able to find the best possible method of delivery of content materials and so to be as close as possible to learner's learning style, which was the core ingredient of this research.

## **Appendix 11 First Conference Paper – AACE ED Media 2006**

### **Issues in Design and Development of Personalised E-Learning Systems**

M.Dastbaz, A.Mustafa, R.Stoneham  
eCentre – School of Computing and Mathematical Sciences  
University of Greenwich

#### **Abstract**

Molyneux (2002) envisaged a future in which everyone will have an electronic personal learning associate. Over the past three years there has been much development in realising this vision. “Personalised” or “Adaptable” E-Learning systems has emerged as a key research area for both educationalists and computer scientists where innovative use of technology is employed in the design and development of new learning environments that meet the need of emerging technically competent users. “eLISA” project funded by the “Joint Information Society Committee” (JISC) in UK has been a joint effort between Schools of Computing & Mathematical Sciences and Education in the University of Greenwich and the University of Oxford’s Department of Educational Studies & Learning Technologies Group, looking at design and developments of Personalised E-Learning environments. This paper presents some of the design and development methodology used to develop a PELS, which is currently being tested.

#### **Background**

Innovation in technology and communications is changing the structure of teaching and learning. Wentling, Waight, Gallaher, La Fleur, Wang and Kanfer (2000) describe how several terms have been used to characterize the innovation and creation that has been occurring. Some of these terms include web-based learning, online learning, distributed learning, e-learning, computer-based instruction, to name but a few. Although there has been much promises, about the e-learning revolution, using the state of the art multimedia technology, closer scrutiny of what is being delivered reveals that much of the e-learning models that are around are little more than the old text based computer aided learning running on a global network.

Kurzel(2004) points out that researchers in e-learning and educational technologists in a quest to provide improved Learning Environments (LE) for students are focusing on personalising the experience through a Learning Management System (LMS) that attempts to tailor the LE to the individual (see amongst others Eklund & Brusilovsky, 1998; Kurzel, Slay, & Hagenus, 2003; Martinez,2001; Sampson, Karagiannidis, & Kinshuk, 2002; Voigt & Swatman; 2003).

According to Kurzel (2004) this tailoring can have an impact on content and how its accessed; the media forms used; method of instruction employed and the learning styles supported.

#### ***Issues of “Adaptability” and “Personalising” e-Learning system***

Much research has been conducted about how we learn and how learners learning style affects this process. From the behaviourist approach of Skinner and Watson to the constructivism of **Vygotsky and Piaget** there has been an on-going debate on how to develop the instructional

design theory in order to provide a much richer learning environment for learners. As traditional classes try to accommodate to different learners and learning style (albeit with little success), there is an emerging debate about the necessity of e-learning environments to accommodate different learning styles. Horton (2000) goes as far as claiming that personality of learners is also an important subject, i.e. are the learners kind of “morning-people” or “evening-people”, “sprinters” or “plodders”, “extrovert” or “introverts”. By considering above points during the instructional design, learners could be reassured of having flexibility and freedom of learning through an e-learning system.

Research in this field indicates that we are far from being able to pass a unanimous judgement on the both technical as well as pedagogical aspects of e-learning in general and personalised e-learning in particular. There is little empirical evidence that personalisation of e-learning has had any meaningful impact or indeed has any substantial advantage over non-personalised E-learning environments (for example see “Learning styles and pedagogy in post-16 learning - A systematic and critical review” report by Coffield, Hall, Moseley and Ecclestone (2004)). Furthermore, there are also debates as to what is adaptability or how one defines adaptive e-learning systems. Kinshuk, P. A., Russell, D. (2002), have classified these in the form of “Adaptable” and “Adaptive” systems. In an adaptable system model which is usually called “Personalised System” users can modify their settings in the system’s environment. As its name indicates, personalisation is a process which user controls the system. But in the adaptive model, the system is the one which is on the control Ketamo (2003). It is also stated that for the sake of a Complex Adaptive Pedagogy (CAP) to be adaptive it should follow three methods. First, the instructor must be sufficiently flexible to give up considerable control. Second, students must be adaptive in being willing to cope with ambiguity. And third, the broader instructor-student relationship itself must be transformed for these mutual adaptive capabilities to be unleashed in this unorthodox teaching-learning environment. [Brian Lofman].

### ***Aims and objectives of this research***

Aims and objectives of this research could be summarised in the following key issues:

- Modelling the architecture of Personalised E-learning System environment – looking at learning styles and prior knowledge as the mechanism for learners to personalise their learning space
- Develop an E-learning environment containing both a Personalised E-Learning System and an E-Learning Systems and then develop appropriate evaluation methodologies to compare the effectiveness of PELS against ELS.

### **Learning Styles and Learning Preferences**

According to Coffield, Hall, Moseley and Ecclestone (2004) there is different and often conflicting assumptions about learning as well as the best-known models of learning styles. Some theories discussing learning styles derive from research into brain functioning, where claims are made that specific neural activity related to learning can be identified in different areas of the brain. Other influential ideas derive from established psychological theories. According to Dunn and Dunn (1992, 1993), Students have learning style preferences. They have mentioned 21 variables that affect learning in five categories:

- **Environmental:** sound, light, temperature, design
- **Emotional:** motivation, persistence, responsibility, structure



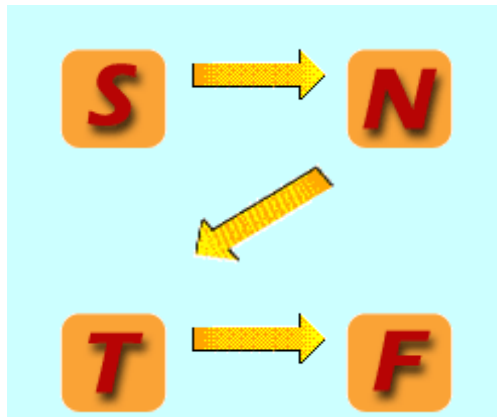
- **Sociological:** learning alone, in pairs, with peers, with an adult
- **Physiological:** time of day, mobility, food or liquid, intake, auditory, visual, tactual, kinaesthetic
- **Psychological:** right/left brain, impulse/reflective, global/analytic

Hwang & Wang (2004) studying learners personality and characters have identified other related issues which include: ambiguity tolerance, anxiety, field dependence/ independence, and active/passive learning, which are relevant to the work we are doing.

On the base of personality types that were first described by Carl Jung in the 1920's, psychologists have found a tool to find people's personality type, which could be used as one of great tools to develop a personalised eLearning system. However, Mayer and Briggs have developed a questionnaire called "Mayers-Briggs Type Indicator", or MBTI. Individual's type of personality is divided into 8 categories including: **Extraversion; Introversion; Sensing; Intuition; Thinking; Feeling; Judging; Perceiving**. Myers (1987) felt that all types - regardless of favoured preference - would benefit by following a systematic process that involved the exercise of all preferences. *He stated that:*

*"Whenever you have a problem to solve, a decision to make, or a situation to deal with, try exercising each process by itself--consciously and purposefully. That way each process can make its own contribution to the solution without interference from any other process. Start with your perceptive processes (sensing and intuition). Perception should always come before judgment."*

Lawrence (1993) pictured this process looks like a Zigzag through the preferences, beginning with **Sensing** and ending with **Feeling**. [MBTI personality assessment].



Looking at the extant literature and the numerous approaches to understanding learning styles we also come across a model abbreviated as VARK which states that the learner could have one of the following learning Styles:

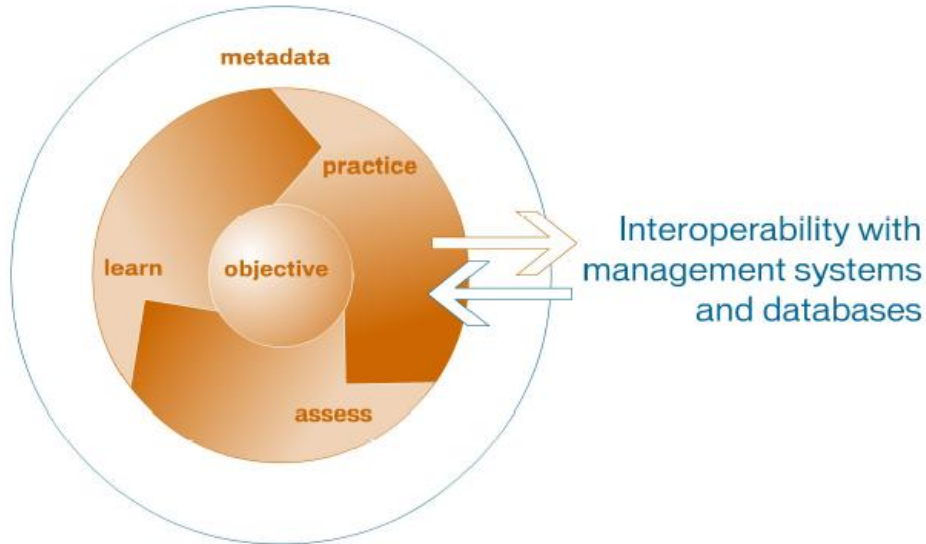
- Visual
- Auditory
- Read & Write
- Kinaesthetic & Tactile

VARK is a questionnaire that provides users with a profile of their learning preferences. These preferences are about the ways that they want to take-in and give-out information. According to (<http://www.vark-learn.com/english/index.asp>) VARK is a short, simple inventory that has been well-received because its dimensions are intuitively understood and its applications are practical. It has helped people understand each other and especially students to learn more effectively and faculty to become more sensitive to the diversity of teaching strategies necessary to reach all students. Although copyrighted, VARK is free for use in student or faculty development as long as attribution is given. It may not be published in paper or electronic form without permission of the authors. If used commercially, say for training, a small fee must be paid.

### Some Issues in Design of PELS

While its clearly outside the scope of this paper to critically review all the approaches and attempts in developing PELS, it seems that one of the key issues common to any PEL development is how we define and implement Learning Objects (LO). Looking at the extant literature one could define LO to contain the following five elements:

- Metadata
- Objectives
- Learning contents
- Practice



**Structure of a Learning Object (*Learnativity.org*)**

Once we have established that our LO consist of metadata and objectives as well as learning contents, which presents knowledge in the form of giving new contents; practice and assess we need to develop a mechanism based upon which LOs are developed.

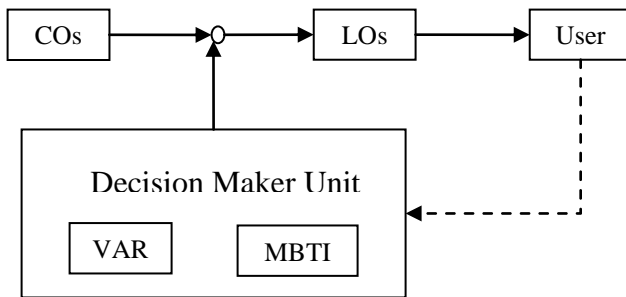
The set of rules that could be employed is listed below:

1. By analysing a learning object, its objectives must be identified.
2. While analysing a LO, its sub sections or individual objectives need to be identified.
3. In design phase, individual context of V, A and R type of Digital Assets (DAs) must be designed, so they will all meet requirements of each individual Learning Objectives.

4. Relationship between above, V, A and R would be defined. Mainly there would be 4 types of relationship. VA, VR, AR and VAR.
5. These types of information on their relationships would be kept on a section of metadata of the learning object.
6. The type of information (in metadata) would be static.
7. Up to this stage, individual DAs have been reused for different COs. That means just by having proper information kept on a Metadata as a means of structure keeper, the rest of information could be developed and presented dynamically.
8. From now on, learning section of a LO beside other practice section and assess sections could be developed easily by having enough information saved in a metadata.

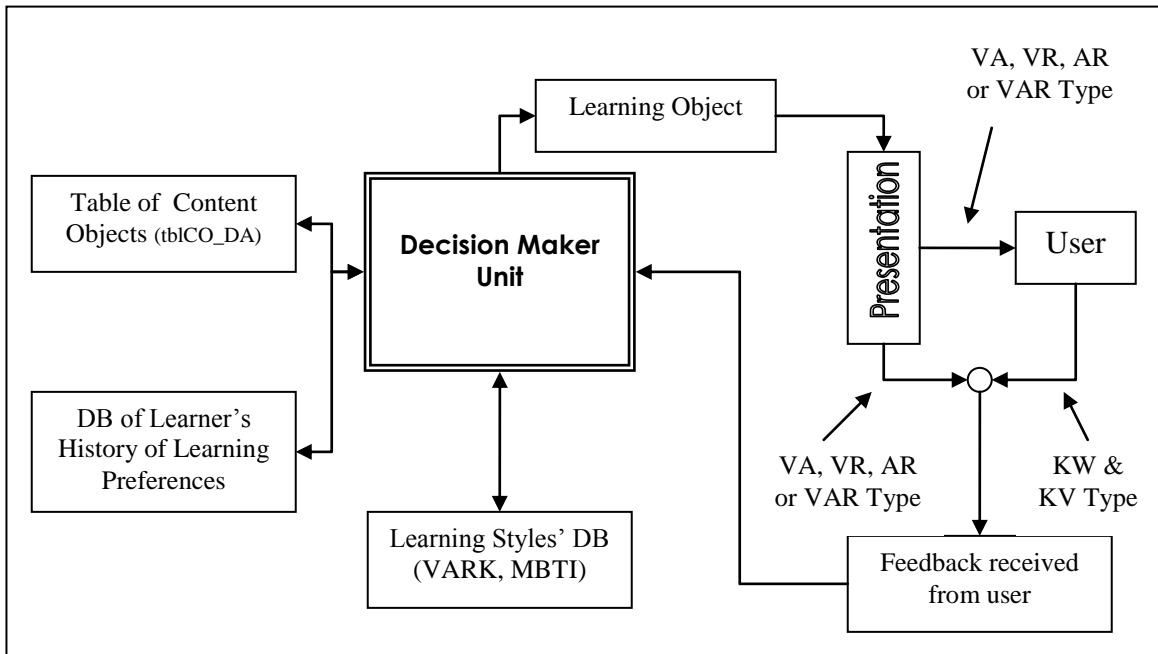
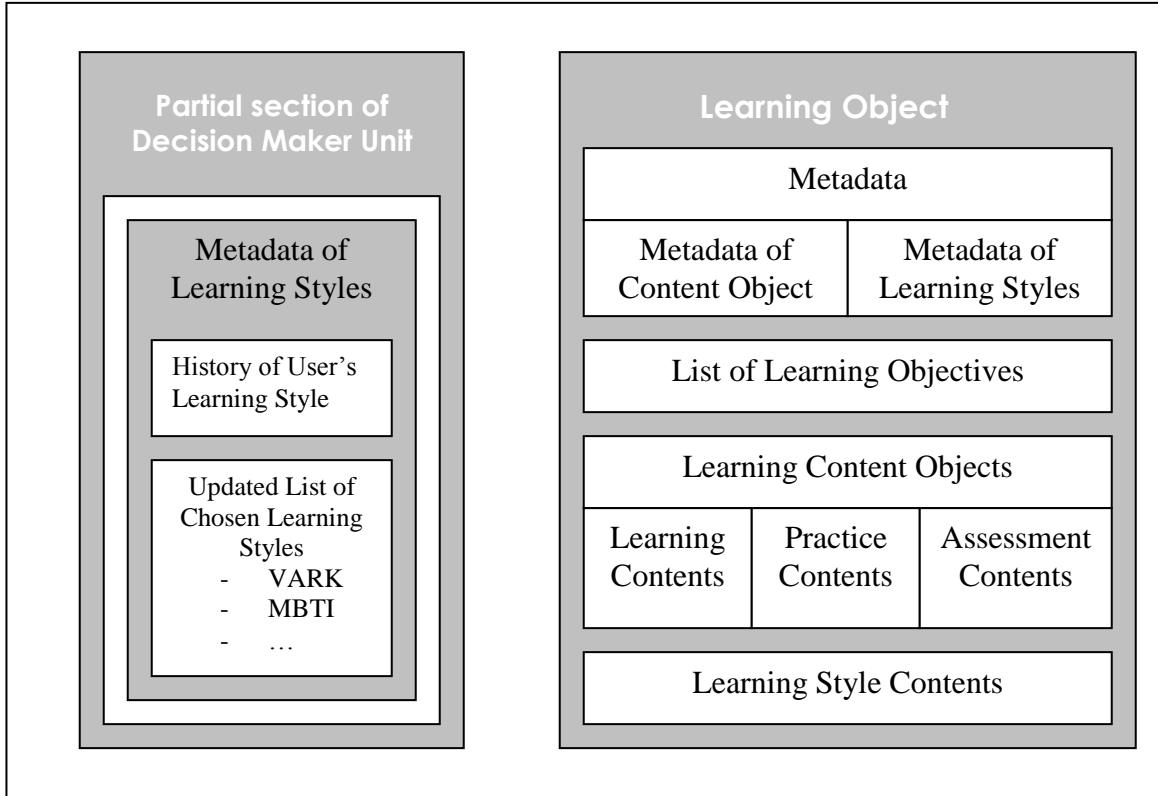
### The Learning Environment Developed

Based on the discussions and concepts presented above our system has been developed. The system is aimed as an “Induction Programme” for MSC students who don’t have a computing background and are trying to convert to computing science subject. Using emerging Web technologies a web based system is developed that can be accessed using a simple Web browser. The system developed uses the VARK questionnaire to allow users to determine their learning preference as well as determining the learners’ prior knowledge in the field. At the heart of the system architecture is a decision maker that receives the user’s requirements and accordingly adjust the “Content Material” (CO).

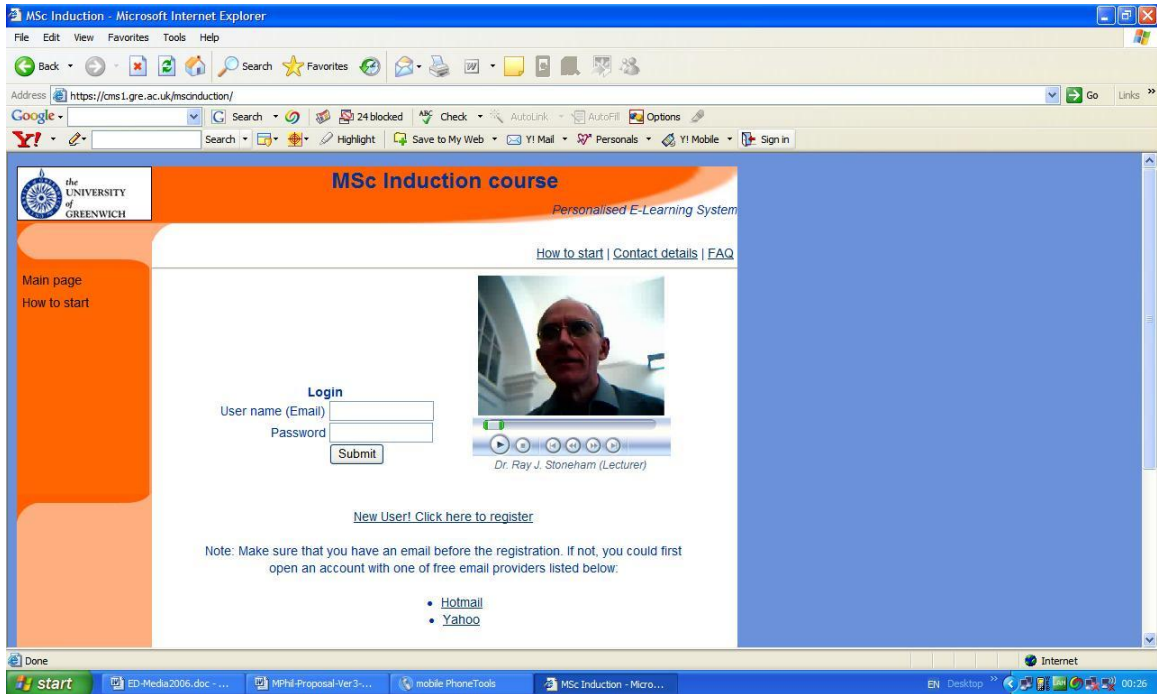


The DU unit has communication with 5 other main sections of the system. Table of Content Objects (COOB) – the table which made the relationship between other table listed as follow: tblDAs, tblCO\_LC, tblCO\_PC and tbl\_AC – DB of Learner’s History of Learning Preference – where system stores Learner’s activities while interacting with the contents – Learning Styles’ DB (LSDB) – such as Psychological Assessment library – Feedback received from user – in the form of ‘KW or KR’ + ‘VA, VR, AR or VAR’ – and Learning Object package – which acts as an outcome of the DMU.

The first and the third packages are just a type of static DB and the second one has a similar characteristic except when it gets updated by entries from the user in the form of feedback – ‘Feedback received from user’ package. These are types of data in response of user’s activities on a presentation, which would update the history of Learners preferences. As it is obvious from this process, the DMU has a great reliability on this package (DB of Learner’s History of Learning Preferences – HLPDB).



*System Diagram of the PEL*



*Screen Shot from the PEL System Entrance Page*

The system is currently in its final beta development stage and will go on-line for testing and evaluation with our MSc students during February and March 2006. The evaluation phase will concentrate on gathering data on Personalised ELS to see if the personalised nature of the learning environment has any impact on the learning outcomes.

The research work carried out thus far as part of eLISA project has resulted in a number of interesting findings. The system developed is unique in terms of taking a direct approach in determining learners preferences by allowing them to indicate these via a VARK test (as opposed to profiling of learners by tracking their behaviour during system usage). Furthermore the system allows users to indicate their previous levels of knowledge and allows them to test their prior knowledge by going through simple tests in order to direct learners to the right level of learning material. The process has also been very helpful in establishing some key issues particularly developing a methodology for the creation of appropriate learning objects.

While we remain very cautious, like many other educational technologist, regarding the whole concept of determining learners learning style nevertheless this project has clearly shown that we can develop systems that allow users to have a direct input in terms of the type and delivery of their learning material. This opens the way for further research in developing more complex engine type tools that are capable of holding large depository of digital assets on various topics and allow learners to just indicate their learning requirements and receive a totally personalised learning system on a given subject area.

**References (full references to follow)**

- Molyneux (2002)

Wentling, Waight, Gallaher, La Fleur, Wang and Kanfer (2000)

**Wentling et al. 2000**

Wentling, T.L., Waight, C., Gallaher, J., La Fleur, J., Wang, & C., Kanfer, A. ( 2000) e-Learning, A Review of Litrature. *Knowledge and Systems Group. University of Illinois at Urbana-Champaign*

- Kurzel(2004)
- Eklund & Brusilovsky, 1998;
- Kurzel, Slay, & Hagenus, 2003;

**Martinez, M. 2001**

Martinez, M. (2001). Key Design Considerations for Personalised Learning on the Web. *Educational Technology and Society* 4(1) 2001. ISSN 1436-4522

- Sampson, Karagiannidis, & Kinshuk, 2002;
- Voigt & Swatman; 2003

**Horton W. 2000**

Horton W., *Designing Web-based Training*, Wiley 2000.

- Coffield, Hall, Moseley and Ecclestone (2004)

**Kinshuk, Patel, A., & Russell, D. 2002**

Kinshuk, Patel, A., & Russell, D. (2002). Intelligent and Adaptive Systems. In H. H. Adelsberger, B. Collins & J. M. Pawlowski (Eds.) *Handbook on Information Technologies for Education and Training*, Germany: Springer-Verlag, 79-92.

**Ketamo, H. 2003**

Ketamo, H. (2003) An Adaptive Geometry Game For Handheld Devices. *Educational Techology & Society*, 6 (1)ISSN 1436-4522

**Hwang & Wang 2004**

Hwang W., and Wang C., *A study of learning time patterns in asynchronous learning environments*. Blackwell Publishing Ltd 2004. *Journal of Computer Assisted learning* 20, pp292-304.

**Myers, I. B. 1987**

Myers, I. B. (1987). *Introduction to Type*, Fourth Edition. *Allan Hammer, Editor*

Lawrence , G. (1993). *People Types & Tiger Stripes*, Third Edition.

## **Appendix 12    Second conference paper AACE E-Learn 2006**

### **Adaptable Personalised E-Learning Systems and Practical Approach on the use of Presentation Applications**

Alan Mustafa, Mohammad Dastbaz, Ray Stoneham  
[a.mustafa@gre.ac.uk](mailto:a.mustafa@gre.ac.uk), [m.dastbaz@gre.ac.uk](mailto:m.dastbaz@gre.ac.uk), [r.j.stoneham@gre.ac.uk](mailto:r.j.stoneham@gre.ac.uk)  
eCentre – School of Computing and Mathematical Sciences  
University of Greenwich

#### **Abstract**

Following our last study [1] on the effect of individuals' learning styles on their learning performance, the study pointed out that it is possible to increase the performance up to some level with considering learners' learning preferences. This paper would expand the relationship between adaptability of e-learning systems with existing presentation applications. This paper is about an approach on setting up a matrix named as ARK-based switchboard and how it is used to relate theoretical-VARK-based with practical approach on producing contents materials.

#### **Introduction**

Innovation in technology and communications is changing the structure of teaching and learning today. Wentling, Waight, Gallaher, La Fleur, Wang and Kanfer [2] describe how several terms have been used to characterize the innovation and creation that has been occurring. Some of these terms include web-based learning, online learning, distributed learning, e-learning, computer-based instruction, to name but a few. Although there has been much promises, about the e-learning revolution, using the state of the art multimedia technology, closer scrutiny of what is being delivered reveals that much of the e-learning models that are around are little more than the old text based computer aided learning running on a global network. This study will be looking at the existing models of e-learning and trying to investigate, design, develop and evaluate a more "Personalised" or "Adaptive" e-learning environment.

#### ***A Need for Learning & Teaching Philosophy***

Arney [3] by proving a short list tried to show a relationship between teacher, knowledge and learner. Few points from the list is as follow:

- Learning needs a medium to occur and it can't happen in a vacuum
- Process of learning is usually facilitated by moving from the known to the unknown
- Memorizing can't be called learning (required more practice and assessment)
- Different learners, different methods and ways on learning

Furthermore, based on the theory of constructivism, humans construct their own knowledge instead of simply being a passive learner and just receiving information. For the past decade many learning model have been suggested towards having a learner-centred educational system (Menges [4]; Felder & Brent [5]; Locatis & Weisberg [6]; Sandholtz et al. [7]; Wolf et al. [8]). By recent developments in the area of Internet and Multimedia, remarkable developments have been made in the area of educational models. Instructional designers and

learners have become more obsessed with the WWW for advancing their knowledge in today's fast growing needs on skilful people in academic related and commercial environments. Despite the fact that many researches on educational psychology have been being carrying on for the past decades, but still there is a gap on having a set of fully defined characteristics exists. However, there are many theory could be found that could be counted as a benchmark towards a set of standard for this research.

## **Background**

One of important part of any elearning system is on the method of delivery of contents materials. One of these methods includes the personalisation of elearning systems. On the base of individual learners' learning preferences (LP), specific type of course materials could be delivered to the learner and be one of many reasons for an increase on learner's learning performance.

As mentioned earlier any personalised elearning system would include two main sections.

- a) Determining learner's LP,
- b) Preparing LP related type of course materials in the form of learning object (LO) and then deliver it to the learner.

## **VARK-based LP determiner**

There are varieties of practical tests available which can determine a learner's LP up to a level (VARK [9], MBTI [Mayer-Brigs Test indicator – [10]] and many more). Although, this process would include some level of truthful reply from learners; whereas, on that base, the variable of LP could be accepted with confidence. On the other hand, while a content developer has a wide range of options on choosing a method for developing course materials, one of variables would be developing any course materials according to all types of LPs so to fulfil requirements of having a personalised elearning system.

According to VARK-Based test to identify a learner's LP, the outcome of a test would be based on categorised on 4 variables, which they are: Visual (V), Auditory (A), Read/Write (R) and Kinaesthetic/Tactile (K). There are 15 possible combinations exist and by considering interactions from both sides of computer to a user and vice versa, there are 30 different types would exist. But this wouldn't be a feasible approach. As the number of contents materials raise, the amount of work would be tremendous which could raise the question of necessity of having any personalised elearning system at first place.

As mentioned earlier, theoretically it is possible to have 30 different types of contents materials, so to fulfil requirements of having a Personalised eLearning System (PELS). But even though, there are evidences exist, which not many learners would choose many types of VARK. On [2 – MSc induction course] evidences would indicate that only 9 types available of combinations options (V, A, R, K, VA, VR, ... VARK) have been chosen, which they are: V, A, R, K, VK, AR, RK, ARK and VARK. So when performance and feasibility of course material development is under consideration, it is possible to have a PELS with good performance and less effort on production side. Although, it still needs lots of effort to develop at least 9 different types of the same contents materials for different LPs. So it is worth to seek an alternative.

## **ARK-based switchboard**

In this section the concept and structure of a matrix named as ARK-based switchboard has been put under study as a core unit of APELS architecture. However, before that it is necessary to learn more about the concept of digital asset and its relation with learning preferences



### Concept of Digital Asset

Digital asset is a metaphor for any kind of digitally produced contents materials such as a piece of text, picture, audio, animation and many more which are able to be stored digitally. As mentioned earlier, the best approach on developing reusable contents materials is to determine what common properties are between varieties of Digital Assets (DA). So the best step is to determine the logical similarities between different methods of creating individual DAs and then content materials, whether it is a Principal DA (V, A, R & K) or complex DAs (VA, ..., VARK).

To clarify the matter, there is a need to define an expression and then determine its relationship with other LPs to create varieties of DAs.

An expression would be created when there is/are relationship(s) between two or more objects exist. Similar to a basic concept of a mathematical function:  $y=f(x)$ , where “f” defines the relationship between variable “x” with different entries to create an expression known as “y”, if those expressions were to be created and at the same time Learning Preferences are considered, the outcome would be in a form of LP-based content materials.

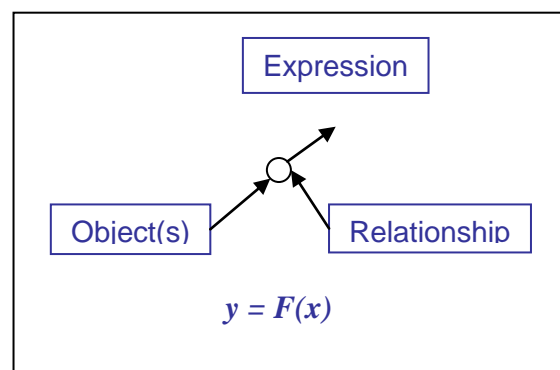


Figure 1: A schematic of defining an expression

Thus, the process of creating DAs as shown in figure 2, would mainly depend on the type of relationship and its time relatedness.

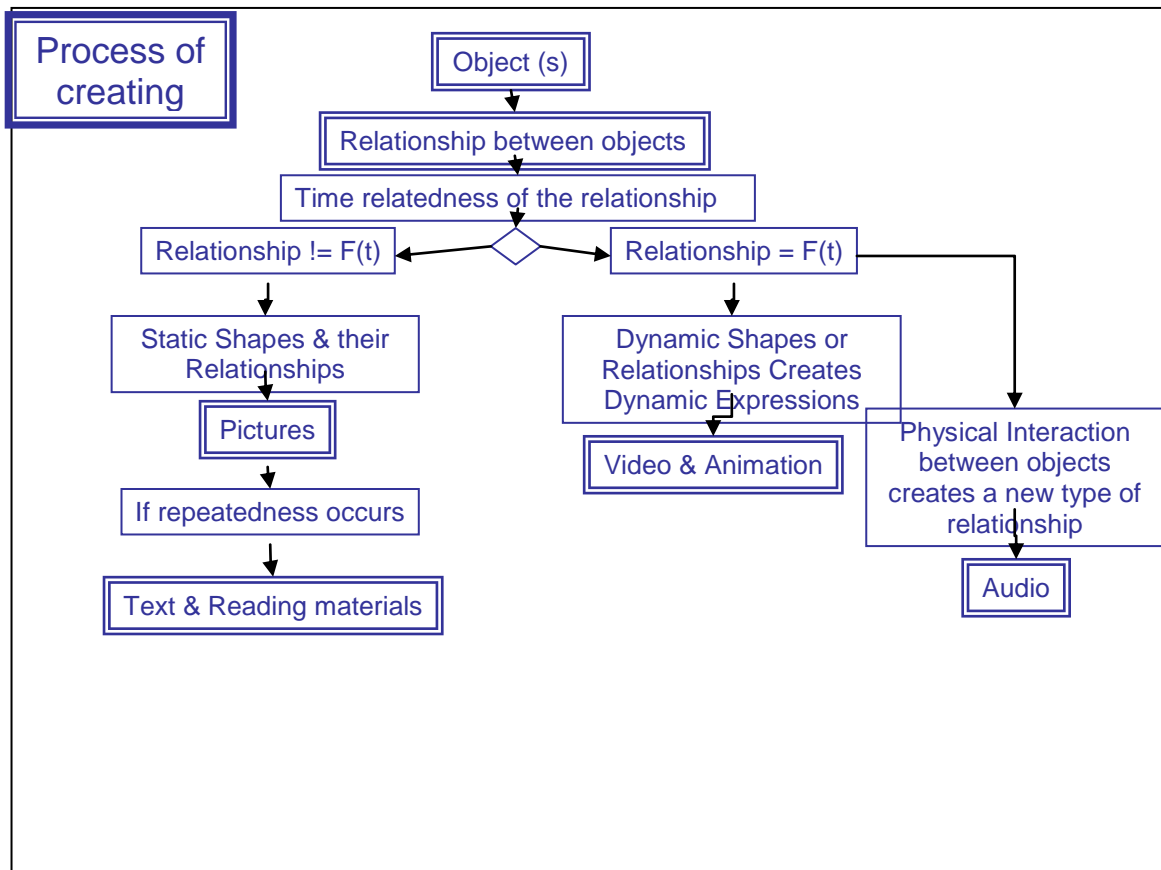


Figure 2: Process of creating Digital Assets

On the other hand kinaesthetic effect could cause change on the type of presented DAs (figure 3); either in the form of interaction with existing DA or starting a new DA in the process (figure 4).

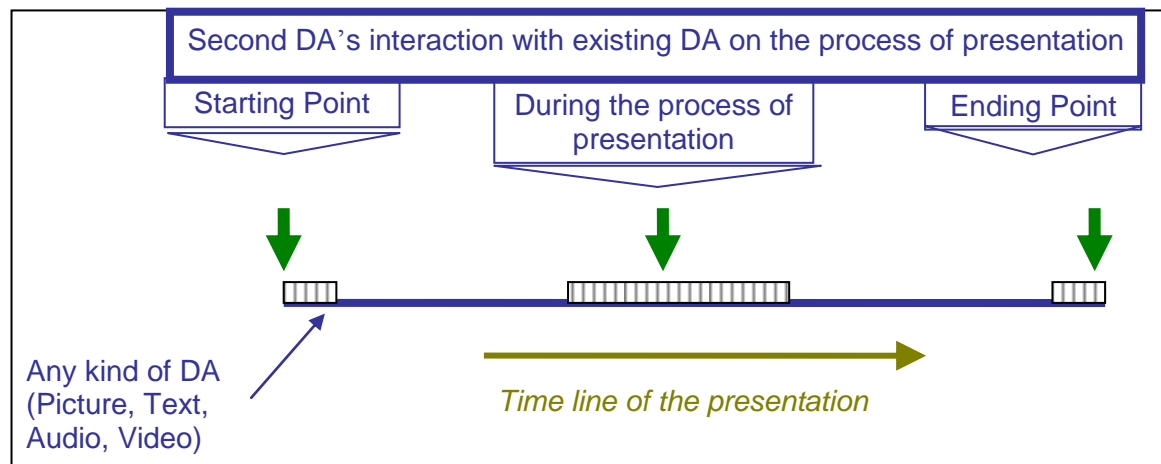


Figure 3: Point of interaction between two Digital Assets

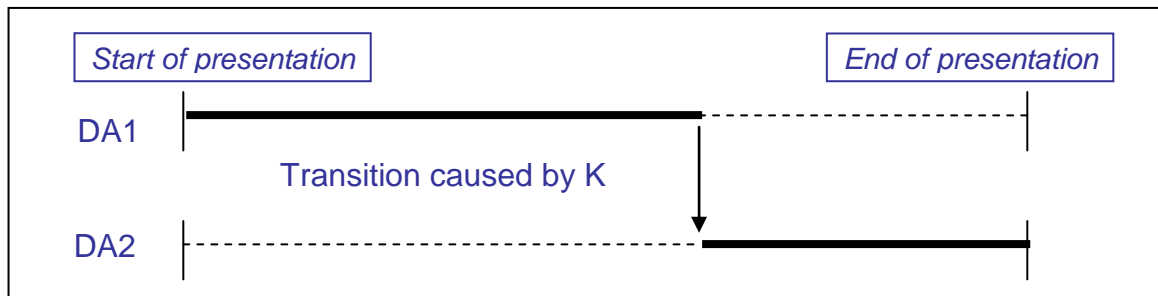


Figure 4: Different perspective of Kinaesthetic type interaction between two Digital Assets

### **What is this ARK-based Switchboard**

As development of any content material needs huge amount of time and effort, it is mandatory to seek an approach which would consider contents development from this point of view. But the main question is how to relate VARK-based types of variables with existing contents development applications such as a presentation application (MS PowerPoint).

As known there are variety of applications exist which could be used for this purpose, either professional or basic tools. Whichever tool being used, their last product would fall on one of categories based on VARK variables. So, it is possible to categories those products based of Basic or Complex VARK variables (V, A, R, K & VA, VR, VK ...). On the other hand when it comes to develop any contents materials, the last product should include combinations of those basic variables so to deliver enough information which would fulfil requirements of an Information-Package. For example, a picture (as a digital asset) could deliver some data but not enough to fulfil requirements of a fully deliverable information package which would be useful and stands on its own without the need for any complex VARK from other data sources. This argument confirms that any fully-deliverable-information-package should include a combination of those basic variables. This is to confirm a system which named ARK- based switchboard.

According to this switchboard, content developer, has a benchmark to refer to while developing content materials. So, while a learner completes the VARK-based test, PELS would convert the outcome to a suitable form with the use of ARK-based switchboard. From now and then the system and content developer would work on the base of ARK type of content materials.

**How ARK-based switchboard works?**

As mentioned earlier, any content materials would include combinations of basic VARK-type variables. There is a set of rule on converting possible VARK- to ARK-based variables as below.

| ARK-based switchboard |   |    |    |   |              |
|-----------------------|---|----|----|---|--------------|
| VARK category         | A | RT | RS | K | ARK category |
| V                     | 0 | 0  | 1  | 1 | KRS          |
| A                     | 1 | 0  | 0  | 1 | AKRD         |
| R                     | 0 | 0  | 1  | 1 | KRS          |
| K                     | 1 | 0  | 1  | 1 | AKRS         |
| VA                    | 1 | 0  | 0  | 1 | AKRD         |
| VR                    | 0 | 0  | 1  | 1 | KRS          |
| VK                    | 1 | 0  | 0  | 1 | AKRD         |
| AR                    | 0 | 1  | 1  | 1 | KRD          |
| AK                    | 1 | 0  | 1  | 1 | AKRS         |
| RK                    | 1 | 1  | 1  | 1 | AKRS         |
| VAR                   | 1 | 1  | 0  | 1 | AKR          |
| VAK                   | 1 | 0  | 0  | 1 | AKRD         |
| VRK                   | 1 | 0  | 0  | 1 | AKRD         |
| ARK                   | 1 | 1  | 1  | 1 | AKRS         |
| VARK                  | 1 | 1  | 0  | 1 | AKRD         |

Table 1: ARK-based switchboard

**Keys:**

A: Audio included

K: Interaction included

RS: Static type of contents materials

RD: Dynamic type of content materials

**Note:** Because the origin of both text and picture are the same, so in this process, both are counted the same. Thus: RP = RT.

**Note:** As it is shown, all types of content materials are included interaction (K) type, because of using a specific type of Flash producer (Macromedia Breeze). The outcome of this application is a type which buttons are used for its navigation through series of slides. So the least type of interaction would be in the form of clicking on a button which would be counted as a form of interactivity.

**Principals of APELS**

Basic idea behind APELS is shown as below (figure 3):

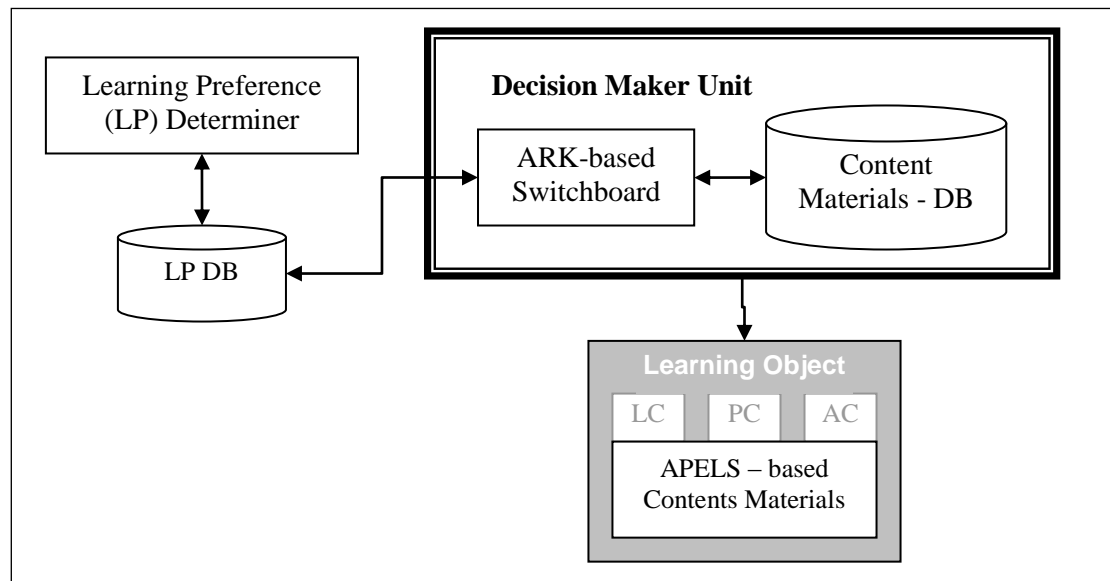


Figure 3: Principals of APELS

- Learning Preferences:  
Learner’s learning preferences would be determined by VARK based test.
- Contents Materials:  
Contents materials are developed on ARK-based approach.
- ARK-based switchboard:  
This switchboard is used by the system (APELS) and acts as an intermediary between learner’s LP and the type of contents materials; so the system is to be able to choose the most compatible form of contents materials and deliver it to the learner.
- APELS tracker  
This part of APELS tracks learner’s activities through out the session while in a learning environment.

**Methodology**

The e-learning system which was developed for this purpose was included a main section named as ARK switchboard. It acted as core component of Decision Maker Unit (DMU). Learners would start to gain access to the system via a self-registration process. After three short assessments of a) Learning Preference Determiner (VARK-based, included 13 questions [9]), b) General IT knowledge assessment (included 10 questions) and c) Self assessment (included 6 questions), learners have access to the contents materials. However, APELS puts learners into two main groups, at the time of registration. They are ELS, and PELS. The ELS is a group which its learners are able to change their LP via a user interface during the course and PELS are those who are not able to do that. The second group is specifically categorised to study the difference between decision makers: “Machine and Human”. The ELS group has human based decision maker for choosing course materials and PELS has machine based principal. The main purpose of this research is to study the difference between these two main groups.

The outcome of the last experience [11] beta version of the system indicated that there are learners who are able to change their LP, have shown some increase on their learning performance. Details are in tables 2 & 3.

| Relationship between Assessment Performance & Learning Preferences |                     |      |            |
|--|---------------------|------|------------|
|  | LP/Main Grand Total |      |            |
|  | UP                  | DOWN | No attempt |
| V  |                     | 5%   |            |
| A  |                     | 3%   |            |
| R  | 8%                  | 3%   | 5%         |
| K  | 5%                  |      |            |
| VK   |                     | 3%   |            |
| AR   | 3%                  | 3%   |            |
| RK   |                     | 5%   |            |
| VRK  | 5%                  | 5%   | 3%         |
| VARK   | 24%                 | 14%  | 5%         |
| Subtotal:  | 46%                 | 41%  | 14%        |
| <b>Total:</b>  |                     |      | 100%       |

Table 2: Assessment Performance and LP

| Relationship between Assessment Performance & ARK based contents materials |                     |      |            |
|--|---------------------|------|------------|
|  | LP/Main Grand Total |      |            |
|  | UP                  | DOWN | No attempt |
| RS   | 3%                  |      |            |
| RD   |                     | 3%   |            |
| ARS  |                     |      |            |
| ARD  |                     | 3%   |            |
| KRS  | 8%                  | 8%   | 5%         |
| KRD  |                     |      | 3%         |
| AKRS   | 5%                  | 3%   |            |
| AKRD   | 30%                 | 24%  | 5%         |
| Subtotal:  | 46%                 | 41%  | 14%        |
| <b>Total:</b>  |                     |      | 100%       |

Table 3: Assessment Performance and ARK-based contents materials

During the period of the course when the system was accessible, 71 learners accessed APELS, 59 learners took the VARK test and determined their LP and 37 learners attempted practice and assessment section of contents materials.

## Discussion

On the base of preliminary analysis of outcome, following topics were found:

1- By the use of F-table, T-table, the minimum average and probability of 5% level of distribution, outcome indicates that learners can be divided into 11 groups of time spent on overall topics.

2- Progress on learners' learning performance can be divided into three groups:

- i) Advancements on Learning Performance
- ii) No Change on Learning Performance
- iii) Decline on Learning Performance

### ***Advancements on Learning Performance***

a- Learners with "R", "K" and "VARK" based LP have shown great advancements on their learning performance by doing better on their assessments.

b- Learners with accessibility of contents materials of type "RS", "AKRS" and "AKRD" have shown a great deal on their learning performance by doing better on their assessments.

### ***No Change on Learning Performance***

a- Learners with "AR" and "VRK" based LP have not shown much change on their learning performance.

b- Learners with accessibility of contents materials of type "KRS" have not shown much change on their learning performance.

### ***Decline on Learning Performance***

a- Learners with "V", "A", "VK" and "RK" based LP have shown a declination on their learning performance.

b- Learners with accessibility of contents materials of type "RD" and "ARD" type of contents materials have shown a declination on their learning performance.

***As this is a research work under progress, results above could be counted on setting a benchmark towards any future development of any course materials of this type related to APELS.***

## Further work

There is a plan to collect more evidences on autumn 2006 by the start of a new course and new MSc students. Because APELS is accessible even before the start of the course, the level of interaction between students themselves are reduced with great deal since students are unknown to each other and the system is accessible outside of the campus, too.

## References:

- [1] M. Dastbaz, A. Mustafa, R. Stoneham. *Issues in design and development of personalised e-learning systems*. Ed-Media 2006 conference.
- [2] Wentling, Waight, Gallaher, La Fleur, Wang and Kanfer. *E-Learning – A Review of Literature*. (2000)
- [3] Arney, Don. <http://faculty.ivytech7.cc.in.us/darney> , , (Last viewed: 15/08/2006)
- [4] Menges R. J. (1994), *Teaching in the age of electronic information*. In *Teaching Tips: Strategies, Research, and Theory for College and University Teachers*, 9<sup>th</sup> edn ed W. J. McKeachie, pp. 183 – 193. D. C. heath, Lexington, MA.
- [5] Felder R. M. & Brent R. (1996) *Capacity Planning for Web Performance: Metrics, Models, and Methods*. Prentice-Hall International (UK) Limited, London.
- [6] Locatis C. & Weisberg m. (1997) *Distributed learning and the Internet*. *Contemporary Education* 68, 100 – 103.
- [7] Sanholtz J. H., Ringstaff C. & Dwyer D. C. (1997) *Teaching with Technology: Creating Student-Centred Classrooms*. Teachers College Press, New York.

[8] Wolf C., Crider L. Mayer L. McBride M. & Sherman R. (1998) *Toward a Miami University model for Internet intensive higher education*. *Journal on Excellence in College Teaching* 9, 29 - 51.

[9] <http://www.vark-learn.com/english/index.asp>

[10] <http://www.myersbriggs.org/>

[11] MSc Induction Course. *This course was running for a period of 3 months start of the beginning of February 2006. New MSc students would able to access APELS to do their MSc Induction course which was one of their mandatory units to complete their MSc.*



## Appendix 13 Data stored on UK's Educational institutions

Data gathered on educational institutions were categorised on the base of their methods of communications with their learners:

Group 1: Whether the institution uses e-learning systems or not.

Group 2: Institution uses computer based training systems (CBT) or web based training systems (WBT).

Group 3: Multimedia Presentations used on their course materials:

- a) Online content materials
- b) Animation
- c) Video scenario
- d) Video conference
- e) Course bulletin board

Group 4: Interactivity

Group 4-A: Interactive static

- i) Email
- ii) Discussion forum

Group 4-B: Interactive Live

- i) Chatroom
- ii) Online tutorial
- iii) Adaptive e-learning system

Group 5: Type of e-learning system used in their educational institution, if any.

**SETI - [tblInst]**

Searched Institutes provide e-Learning Systems

Institute ID: 75  
 Institution Name: University of Greenwich  
 Institution Uses eLearning:   
 Institution Uses CBT:   
 Institution Uses WBT:

**Multimedia Presentation**

Institution Uses Online Content Materials:   
 Institution Uses Animation:   
 Institution Uses Video Senario:   
 Institution Uses Video Conference:   
 Institution Uses Course Buletin Board:

**Interactive**

Institution Uses Interactive Static:   
 Institution Uses Interactive Live:   
 Institution Uses Email:   
 Institution Uses Discussion Forum:   
 Institution Uses Chatroom:   
 Institution Uses Online Tutorial:   
 Institution Uses Adaptive eLearning System:

Link to Institution: <http://www.gre.ac.uk/>  
 Notes on Institution: Some Departments use a basic type of communication (such as email) but some uses WebCT as their online learning vendor. However I couldn't find any more information by using serch engines, but because I had knowledge of having a direct access to that pirticular link, I learned that this University

University of Greenwich

List of Institutes

| ELSP ID       | ELSP Name            | Link to ELSP  | Notes on ELSP |
|---------------|----------------------|---|---------------|
| ▶ WebCT       | WebCT                | <a href="http://www.webct.com">http://www.webct.com</a>             |               |
| * Lotus Learn | Lotus Learning Space | <a href="http://www.lotus.com/produ">http://www.lotus.com/produ</a> |               |

Record: 1 of 2  
 Record: 75 of 195

Form View

The outcome of the preliminary analysis is as follows:

|   | Number of Edu. Institutions | Ratio compared to the total number of Institutions searched for |
|---|-----------------------------|---|
| Total No. of inst. under research           | 195                         | 100%  |
| No. of inst. use eLearning Systems *        | 90                          | 46%   |
| No. of inst. use particular LMS             | 56                          | 29%   |
| No. of inst. use Adaptive eLearning Systems | 0                           | 0%  |
| No. of inst. used WebCT                     | 29                          | 15%   |
| No. of inst. used BB                        | 16                          | 8%  |

## **Appendix 14 Methods of Instructional Designs**

In the previous sections, a concern was raised that there is a doubt about current methods of instructional design which aims to making the learner well equipped to gauge and act on day-to-day life problems (sec 2.3.1), the issue lead to another fact that instructional designers might not be aware of all the facts involved in the creation and transmission of knowledge (Lofman, B., 2002), which means those teaching materials should be designed in such a way that leaves a space for learners to navigate through the presented knowledge but supported by well guided instructions.

On the other hand there were facts found that there are relationships between personalised learning systems and individual's learning style. All these concerns led to further exploration of existing learning environments and thus the transmission of knowledge.

Sections 2.2.1 and Appendix 9 confirm the need to understand the relationship between personalisation of e-learning systems and an individual's learning style. Decisions made on an individual level for the selection of a path to learn a concept or a skill, is made in the stage of strategic knowledge. In that respect, as mentioned earlier, the understating of different methods of instructional design would provide further details on understanding learning philosophies.

***Pedagogy- (Teacher-Centred) and Andragogy (Learner-centred) -based learning environments:*** The origin of word Pedagogy comes from the Greek words “paid” meaning child and “agogos” meaning leading. Thus pedagogy means the art and science of leading and teaching children (Hiemstra & Sisco, 1990). Its applications

were applied in the middle age churches to prepare faithful, obedient, and efficient servants for churches. Those special educational institutions were following pedagogical instruction to develop skilled monastic (Knowles, 1984). Pedagogical method was/is applied only on places where here is a total obedience to the teacher and given instructional methods was/is required. The main pitfall of this method is that the whole purpose of this educational method is to prepare students to show a level of competency in getting a grade to pass the minimum level of competency (designed and developed by the teacher) and then progress to the next level (Hill, L.F., 1991).

Malcolm S. Knowles (1968, 1975, 1980, 1984; Knowles & Associates, 1984), was the main force behind popularizing the concept of Andragogy as a new method of instructional design which was introduced in North America and then a few other European countries, such as Poland, Hungary, and Yugoslavia; they also used the term prior to 1968. Stewart (1986a, 1986b) notes that Linderman (Anderson and Linderman, 1927) has used the term as early as 1927 which is a follow up to the German author of the 1920's Eugene Rosenstock. However, evidences exist (Davenport and Davenport, 1985 and Reischmann, Jost, 2000)) that the origin of the word has been practiced in 1833 by Kapp (Kapp, Alexander, 1833), a German teacher.

Knowles (Knowles, 1980, pp. 44-45) introduced four main concepts in the definition of andragogy, which then with the support of his colleagues were updated to six (Knowles, Holton and Swanson, 1998) assumptions (Reischmann, Jost, 2004 and Fidishun, D., 2000), and they are as follows: (i) the learner's need to know: it is a step

towards guidance of the learner to find out about its correct needs, (ii) the role of the learner's experience: while progressing through contents of taught materials, learners would create a reservoir of experiences which can be used later on to build learning, (iii) the learner's readiness to learn: students willingness to learn increases including further social interactions, as such learners will be more co-operative, collaborative and supportive, (iv) the learner's orientation to learning: another key component of andragogical philosophy of learning is related to its approach to apply knowledge immediately rather postpone it to another time; and the change of perspective from subject-centred to performance-centred, (v) the learner's self-concept: self-description moves from teacher-dependent thinking to independent and more self-directed (which lately has become the 'heutagogy' method of instruction; more will follow), (vi) learner's motivation to learn: there may be external factors to encourage the learner to learn, but the motivation should come from within; examples might be increased self-esteem, job-satisfaction and quality of life. The core approach in andragogy is the guidance of students in "learning how to learn", which gives the responsibility of learning to the learner and as such, they will be held accountable for their own learning.

In other words, in the pedagogical approach, the knowledge will be transferred to the learner in a teacher-centred environment where the teacher is responsible for preparing the knowledge in such a way as s/he sees fit without considering an individual learner's learning style. On the other hand, the learner-centred approach is a method of delivery of knowledge where knowledge is prepared in which the learner is able to take the responsibility for his/her own learning under the supervision of a relevant tutor (Wagner & McCombs, 1995 and LeJeune, N. F., 1998). However, this

approach would create many additional issues such as: intentional learning, active learning, authentic learning, open learning, and many more which are covered in the original reference (LeJeune, N. F., 1998).

***Beyond Pedagogy and Andragogy and moving towards Heutagogy:*** Hase and Kenyon (Hase & Kenyon, 2000) on the support of Rogers (1969) statements on the use of a learner-centred approach, suggest that life long learning is in human nature and indeed argues that teacher-centred learning has been over-emphasised through the history of education. As such Hase, Kenyon and Rogers have pointed five key hypothesis as follows: (i) a learner can't be taught directly, and all teachers can do is to facilitate learning; (ii) only those components of teaching materials are learned by learners which can directly enhance their life, (iii) a learner's nature tends to resist the new change of self through denial or distortion of symbolisation, and then it becomes more rigid under continuous threat; (iv) a learner accepts a new inconsistent experience with their current state of knowledge, only when the self is ready to accept it; (v) as such, the effect of threats of learned materials on the current state of significant learning should be kept to minimum, so to overcome the process of self-directing while receiving new knowledge (in the form of learning).

***Heutagogy:*** On the base of argument made above, a new method of transferring knowledge to the learner has been introduced known as heutagogy. Heutagogy is the principle of teaching based upon the concept of truly self-determined learning. In this method it is assumed that learners have the capability of self motivation and self-determination to manage their own skills and knowledge needed to survive in the

twenty-first century. It is assumed that this approach would foster an individual learning approach on the base of self-analysis of learner's own needs (Hase, S. & Kenyon, C., 2000).

***Selection of the Correct Strategic Learning Perspective:*** As stated above, it is essential to consider which one of the above knowledge transferring strategies should be chosen before designing the instructional system. Besides, to learn more about the kind of strategy to choose from, studying learning philosophies further would determine the scope and boundary of the required system to facilitate the process of designing an e-learning system.

## **Appendix 15 Instructional Design Models in Different Philosophies**

To gain some perspective on the learning process, theories and philosophies have been developed to give a structured understanding of the process of transferring knowledge known as learning mediums (Barnett J. 2002 and 2004). Understanding these philosophies would be the backbone design of the e-learning system being developed and its specifically designed and developed contents materials. Detailed descriptions on the design of such systems will be discussed in Chapter 3, Chapter 4 and Chapter 5.

Instructional design is a set of procedures which if followed, will facilitate the transfer of knowledge, skills and attitude to the learner (InstructionalDesign, 2009).

**Behaviourism:** To overcome the issue of understanding existing philosophies and methods in the process of transferring knowledge in the form of teaching and/or learning environments, researchers have developed philosophies to address this issue. Behaviourism (Pavlov, I. P., 1899; Skinner, B. F., 1938) is a theory of learning that focuses on observable behaviours rather than mental activities or philosophical concepts of the brain and learning. Behaviourism originated with animal studies and relies heavily on quantifiable research to make judgments about how people behave when learning new material. The behaviourists, claim that learning can be inferred by the adoption of new behaviours and that animals and humans alike learn best when



they are given immediate positive conditioning or reinforcements such as praise, food or other rewards. (Atherton, J. S., 2005)

A behaviouristic approach has been applied to a partial section of this e-learning system. It will be used as the basis for giving praise to learners while practising on a few examples or taking any assessment.

**Cognitivism:** Mead (1932/1977) and Vygotsky (1934/1978) have argued that the initial and basic system of cognitive growth in nature is communicative and it is the cause of a “resultant” act of the communicative method (Vygotsky 1978).

The Cognitivist School made the inside of the learner’s head a primary object of their study and tried to discover and model the mental process on the part of the learner during the learning process. In this school, mental construction in the minds of learners are described as knowledge and viewed as symbolic, while the process of committing these symbolic representations to memory is called learning, they may be processed further by the learner to produce new information and knowledge. Strict “input – processing – output architecture” of computers development from the 1960s and up till today certainly have stimulated these “information processing” views of learning [Siemens G., 2005].

This approach utilizes the new vision of “information-processing concept” rather than behaviouristic assumptions where the learner is determined by his environments and so passively adapts to the circumstances. This cognitivist view accentuates active mental processing on the part of the learner. Although, knowledge is still viewed as given and absolute just like in the behaviouristic school.

Dillenbourg and Kumar [Dillenbourg et al.1994, Kumar 1996] classifies three different theories of learning that could be employed in collaborative learning systems:

***Socio-constructivist theory:*** On the basis of this theory, learners approach learning via interacting with others [Doise 1990]. In socio-constructivist theory, emphasis is on interactions rather than actions themselves. This philosophy has not been practiced in this research but would be in future studies.

***Socio-cultural theory:*** This theory supports the fundamental relationship between social interactions and the individual's cognitive development [Vygotsky 1978]. Similar to socio-cultural theory, it has not been practiced but would be used as a benchmark towards the design method of future types of e-learning systems.

***Shared cognition theory:*** In this theory (Brown, Collins, & Duguid, 1988; Pajares 2002), the environment where learning takes place is in focus. This environment includes both the physical and social context, and which emphasises on parts of contexts where relevant knowledge and skills will be learnt. Few advantageous of this method are:

- Applied knowledge would be acquired by linking a specific context to the knowledge to be learned, under which peers learn about necessary conditions for its applications.
- Creative thinking would be achieved by promoting situations. Learners usually can apply newly learned knowledge in real life and different situations.
- As the shared cognition theory is a type of knowledge which is more practical in nature, such as activities involved in discussion boards and teams works, it

is viewed as a process of building and maintaining a shared common sense, its understanding and conception of a problem, so to ensure a natural learning environment.

Because of the type of practicality involved in this theory which is a direct interaction with other members involved on shared cognition (as its mandatory requirements), it is not feasible to design and implement an e-learning system which would investigate the adaptivity, adaptability and/or personalisation of e-learning systems.

**Constructivism:** As the title may imply, constructivism emphasizes the building (i.e., constructing) knowledge that occurs in people's minds when they learn. A simple way to explain this idea is to refer to Gestalt theory (Dabbagh, 1999); that is, the idea that “a whole is more than the sum of its parts”.

What is meant by constructivism is that it refers to the idea that learners construct knowledge for themselves – each learner individually (and socially) constructs meaning – as he or she learns. This school of philosophy focuses on preparing the learner to problem solve in ambiguous situations.

This theory holds a major part of the design process of the system under study and this will guide the learner while progressing through the learning materials. The method which this type of e-learning system uses is the method of interaction with learning materials in a format where learners have to interact with the whole contents of learning material known as a learning object. Detailed description on this concept is provided on chapter four.

**School of Cognitivists and Constructivists:** By comparing the above learning philosophies two other new theories were developed which combine both the cognitivists and constructivists schools of thought. The first theory emphasizes the exploration and discovery on the part of each learner while explaining the learning process known as “Cognitive Oriented Constructivist Theory” and the other emphasized groups of learners’ collaborating as sources of learning which is known as “Socially Oriented Constructivist Theory” (Meriluoto, J., 2003). While the first theory was interacting with knowledge in the form of a symbolic and mental representation in the mind of the individual, the other theory was evolving the learning environment in the field of CSCL (Computer Supported Collaborative Learning). In that respect these two theories have been mentioned here only as part of referencing to learning theories and will be practised and investigated further in 2.6.1.

**Humanisms:** According to humanism, otherwise known as activity theory, the best method of understanding the human mind is to understand the interaction between learners (as subject) and the world (as objects) (Leontiev, 1978).

To envisage this interaction, a hierarchical annotation would be required: (i) at the first level, learners’ needs and motivation towards objects in order to fulfil those needs, (ii) actions towards achieving those motivations to help the learner to meet originally devised goals, (iii) and at the third level, activities that a learner would perform to achieve those goals. There has been a continuous and growing interest in Humanism or activity theory specifically in the area of Human-Computer Interaction (see, e.g., Favorin, 1995; Teasley and Roschelle, 1993).

Edward F. (1989) defines Humanism as a school of thought, in which he believes the human approach to interact with a new environment, is different from other species and so is the learning approach. The concept of open education is also supported by this fact that according to Huitt, W. (2001), there are a variety of ways teachers can implement the humanistic view towards education. One of those points related to this study is to allow the student to have a choice in the selection of tasks and activities whenever possible. Application of humanism theory has been practiced in the design and development of this research through giving choices to learners as a list of available teaching materials. Structure and methods of presenting the materials in the form of learning contents, practice contents and assessment contents will be explained further in Chapter 4.

**Connectivism:** George Siemens (Simense G., 2005, 2006) asserted a new learning theory by forming sets of connections which would construct knowing and learning. The network-forming process between pieces of information and knowledge is the foundation of connectivism. Downes (2005) also counts connective knowledge as the epistemological foundation of Connectivism as stated below:

*“A property of one entity must lead to or become a property of another entity in order for them to be considered connected; the knowledge that results from such connections is connective knowledge.”*

Six principles of connectivism listed by Siemens (2005) are as follows:

- a. Learning is a process of connecting specialised nodes or information sources.
- b. Knowledge is stored in a structure in the form of a network
- c. Learning and knowing are on going processes, no end dates or products.

- d. Ability to see connections and recognise patterns and make sense between fields, ideas and concepts is the core skill for individuals today.
- e. Decision-making is learning. While there is a right answer now, it may be wrong tomorrow due to alterations in the information climate affecting the decision.

Further to the list above, the last rule emphasises the correlation between human knowledge and technology which is the key factor and the bases of this research:

- f. Knowledge may reside in non-human appliances and learning is facilitated by technology.

The last rule (rule f) formulates the bases of technological advancements in the field of e-learning. By providing facilities to make knowledge transportable via a medium which is a non-human appliance, this theory indicates the use of technological challenges towards developing an e-learning environment.

The applicability of this theory is known in all technologically based learning systems (such as e-learning systems which use technologies in traditional classrooms via the use of books and other teaching facilities); and additionally, in the development of the e-learning system under-study.

**Concluding remarks:** Further study in existing learning theories and their relationship to the diversity of learning styles, leads this research to the conclusion, which the study about individual's learning styles and psychological perspectives, should be expanded to clarifying the association between both human's learning

methods and the applicability of technology for the purpose of knowledge transferring.

## **Appendix 16 Learning Duration (Length of Learning, Learning Time Pattern)**

By studying the relationship between learning and its duration, researchers such as Carroll (Carroll, J. B., 1963), Bloom (Bloom, B. S., 1971) and many more (Hwang & Wang 2004) have confirmed that the achievement of a learner has a close connection to the time spent on learning i.e. a learner achieves more by spending more time on learning. Hwang & Wang (2004) in this relation have come to conclusion that:

- There is a direct relationship between the intensity of a learners' reading and their achievement.
- The more diligent the learner, the higher their achievements.
- A level of dropouts is higher in Prior Burst, Negligent and Prior Burst – Negligence. For further clarification, the definition of “burst” in telecommunication field, refers to the phenomenon of sudden data-transmission (Daniel & Virgilio 1998). As such “prior burst” type of learners are whom spent more time at the beginning or early phase of the joining the course. Learners with the habit of frequently logging in to the system would also be counted as prior burst. Furthermore, learners who take their online course carelessly are considered as part of the negligent category.
- Despite the nature of asynchronous courses, and learning autonomy or self-paced learning environment, instructors should encourage learners to study and to exercise self-discipline regularly.
- Although, a variety of solutions could be made to support a learner's practice in self-discipline for online reading, it shouldn't make the learners feel that



they are facing a set of deadlines, because such a learning environment could make the learners feel overwhelmed and it could increase the level of dropouts.

- By allowing a learner to compare their diligence level to another learner involved in the course (either an existing student or from the history of the course), this can motivate learners to do better.
- By availability of burst state and diligence state analysis, instructional designers could observe the time distribution directly from their pedagogical perspectives, thus generating more pedagogical meaning. The instructional designer would have better picture on the quality of teaching materials and learner's interaction with them. The effectiveness of materials and the way learners interact with learning materials, would shown a pattern which will help the instructional designer to make the necessary adjustment to the materials form pedagogical perspective. Reasons behind learners behaviour and his/her interaction during the burst state and diligence states could be further analysed, and answer to questions like, "why students behave during the burst state and how they can continue with the same motivation and concentration throughout the course?"

## **Appendix 17    Learning Object**

### 17.1    Summary of this chapter

This chapter will be the discussion on a method of repackaging the content materials which will be compatible with the type of e-learning system under study with the consideration of learner's learning styles.

### 17.2    Learning Object

#### 17.2.1 Introduction

This section will examine the concept of Learning-Object (LO), existing arguments between ELS designers on that concept and issues on the use of terms like “delivery of knowledge to the learner via an adaptive, adaptable or personalised learning system” (see sections 2.2 and 2.3). Those arguments seem to soften when the core issue is about the definition and design of an adaptive, adaptable or personalised e-learning system; whatever the outcome to be, the main concern and aim of such systems is about learners who are able to gain knowledge after each session of interacting with a packages of contents materials or in another word, learning objects.

In addition, the vocabulary of learning objects has been used in different terms for the past many centuries as it is known as traditional teacher-student classes. Teacher selects a topic for a day, talks about it, writes and discusses few samples as practice on the board, and possibly runs a written assessment session by the end of the class. The idea of learning object is almost similar, but, with two major differences: (i)

learning object is in a digital format, and (ii) it is smaller in size and shorter in the duration of its presentation time.

In this chapter, following topics will be discussed for further understanding of learning objects: “What a learning object is; Granularity and its rule as part of core definition of learning objects; Does size matter? And if it does, what is a standard size of a learning object? Types and categories of content materials are also part of this debate. Concept of expression, objects, digital assets, relationship between individual’s learning preferences and varieties of digital assets so the need to define “Learning Preference-based Digital Asset”; and at the end, the need and concept of ARK-based switchboard will be examined.

### **The need for learning object**

Within the community of instructional designers a concept is famously known towards identifying one of milestones of designing ELS, and it is Learning Object. As LO indicates, and will be reviewed thoroughly in following sections, towards presenting any form of knowledge and by the use of any means of hypermedia, there must be a learning object to be introduced. Despite the fact that its size, type and other object related issues are the main concern of this thesis, but the type and format for presenting them (through a learning-object-viewer), counts as a major decision making factor towards interacting with learning objects.

### **Concept of Learning Object**

Different experts in the field have given different definitions to the concept of learning object. Wiley (2000) has described a learning object as an entity which is in

digital format so it can be reused to support learning objectives. Rehak and Mason (2003) have a similar description but with small changes to its definition, so to be known as a digitised entity within technology supported learning environment. This contradiction expands while CETL (2007) says they should be web-based and interactive digital contents. But these arguments broaden from the other side when IEEE LTSC (IEEE LTSC, 2002) sets a wider option in the form of a standard – IEEE 1484.12.1 – and allows the use of “any entity in the form of digital and non-digital resources to be used for learning for the purpose of education or training.”

Identifying similarity and dissimilarity on defining a concept for learning object continues by a definition from a group of experts in wikipedia [Wikipedia]. According to Wikipedia, learning object is a “collection of content materials that fulfils requirements of a set of learning objectives which can be mobilised and be interacted with other e-learning systems.”

DLNET (2003) defines a learning object as a “structured and standalone resource that combines high quality information in such a way, which facilitates learning.”

Sicilia et al. (2004) delineates a “structured-based classification for a collection of learning objectives and its related content materials, in the form of a description of explicit types of learning objects inside ontology, which provides an approach to formally specify specialised alternatives of metadata records. It also classifies learning objects unconditionally in a random number of dimensions aimed at pedagogical selection.”

*“The main benefit of this approach is the reuse of existing precise type definitions, and the flexibility in adding implicit categories, that*

*can be freely overlapped due to their logical and precise characterization.”*

(Sicilia et al. 2004)

This is an approach which sets a benchmark on framing a definition for a size of a learning object. This topic has been described fully in the following section.

With regards to the topic of automation of learning activities, automated pedagogical selection of learning objects and the engagement of learning preference based learning objects, they demand a specialized sub-ontology in the form of a specific and individual learning object related metadata so to be ready and be used for any kind of learning management system. The demand is based on the completeness of the needed metadata for storing learning style related learning objects towards automation of the learning management system.

Jones (2003) clarifies that conformance or being conventional to technical standards is not adequate to allow reusing a learning object. As Boyle (2003) points out, while the work on technical standards is valuable, it is not enough on its own, to ensure the reusability of learning objects. Little work, it seems, has been done on the design of the learning objects themselves and what design principles need to be employed to make learning objects reusable.

### 17.3 Learning Object Structure

Thompson and Yonekora (2005) emphasize the unavailability of any existing standard learning object structure among practitioners today. The presented form of learning objects ranges from static text, recorded audio files, animation and video segments all

the way to complete modules or lessons. However, according to Hodgins' (2004a, 2004b) those segments do not necessarily fall under the category of learning objects; neither do the lessons or modules. As he indicates that in the best circumstances, "learning objects are situated at the intersection of contextualization and reusability. That is, learning objects have to be sufficiently broad in scope to be meaningful to students and useful to faculty while being granular enough to be reused in various contexts."

### 17.3.1 Granularity

Experts in the field have described granularity of digital learning resources as a characteristic of its size, decomposability and the extent to which a resource is intended to be used as part of a larger resource (Recker, Dorward and Nelson, 2004; Reusable Learning, 2007). It refers to how thoroughly learning objects could be broken down and stored. The unit of a learning object can be a program, a course, a module, a lesson with practices and assessments. Generally granularity refers to the relationship between reusability and the size of a learning object. However, it is necessary to mention that the greater number of smaller objects requires an increase in their manageability (LOC, 2007).

***Granularity and Content Models:*** Following the clarification on the concept of granularity, IEEE LTSC standard (IEEE LTSC, 2002) has described the functional granularity as an aggregation level and to draw a clear picture on the use of learning object metadata (LOM). IEEE LTSC (IEEE LTSC, 2002) offers the following scale as a collection of five levels for aggregation levels as part of its standardisation for learning object (Figure 79):

- Level 1: Set of wither two/more objects or one object and its background environment, so to form the basis for defining a digital asset.
- Level 2: Smallest level of aggregation. For example: digital or non-digital assets, raw media data or fragments.
- Level 3: A collection of digital assets in the form of learning objects; for example; a lesson.
- Level 4: A collection of learning objects; for example; a course.
- Level 5: The largest level of granularity; for example; a set of courses that lead to a certificate.

**Size of a Learning object:** Varieties of arguments exist on defining and determining a list of characteristics of a learning object. List of objectives, size of content materials, methods used to access its contents through any plug-ins, structured-based metadata to embrace (its objectives and contents), interact with the learning object (as whole) and methods of interactions, all together are few issues of this argument in the field of learning object and instructional design. But, whatever the circumstances are:

Relationship between the size of an object and its reusability is one of probabilistic issues.

[Wiley, 2000].”

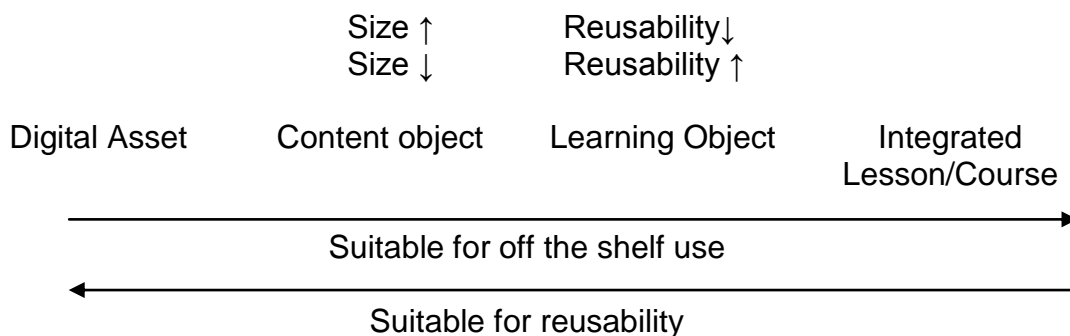


Figure 79: Basic graphic representation of the granularity of a learning object

Wiley (2000b) comments on giving an example on why debating and not reaching on a standard format on the size of a learning object shouldn't keep us from exploring the field brings an example:

It is commonly accepted that atoms are not the smallest bits of stuff in the universe. Atoms are in fact combinations of smaller bits (neutrons, protons, and electrons), which are combinations of smaller bits (baryons and mesons), which are combinations of even smaller bits (quarks, anti-quarks, and gluons), etc. Curiously, it is the particular manner in which these top-level smaller bits are combined in an individual atom that determines which other atoms a particular atom can bond with.

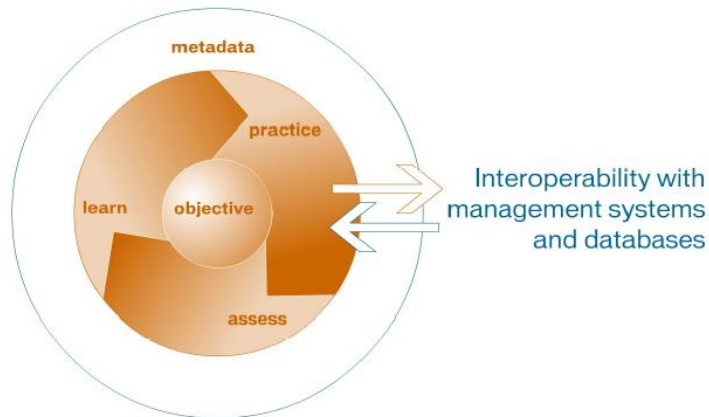
[Wiley, D. A. (2000b)]

By comparing an atom as a learning object, an atom is a collection of some other particles and they are too. However, an atom has been identified in more depth including general and specialised knowledge of its properties. The most part of classical physics has been built on and as a result still engineering world is advancing, applied physics including chemistry is on the move, too.

### 17.3.2 Anatomy of a Learning Object

Content analysis of any topic requires decomposition and analysing of learning objects. See Figure 80.





**Figure 80: Structure of Learning Object (LO)** (<http://www.macromedia.com>)

A learning object is defined as a combination of five segments:

- Metadata (Segment 1)
- Objectives (Segment 2)
- Content Materials
  - o Learning contents (Segment 3)
  - o Practice (Segment 4)
  - o Assess (Segment 5)

As part of standardisation of approaches and definitions on learning objects (IEEE LTSC 2002), metadata and objectives are parts of the structure of a learning object, but contents sections are classified on another group. Learning contents acts as presentation of knowledge in a package in the form of giving new contents; Practice and Assessment sections are similar to each other in the form of requesting knowledge in a specific way, but the assessment section does not include the discussion (explanation of the answer) segment.

To be specific here, learning objects could be divided in to three main groups as follows:

- a) Data about data (Metadata and Objective),

- b) Outputting data in the form of presenting information to a learner where Learner acts only as a receiver – (Learning content), and
- c) Combination of giving and receiving data where feedbacks would be required from learner – with Learner acting as a transmitter (Practice and Assess)

**Metadata:** Metadata similar to library catalogues which lists details (type of the resource, author, date published, version, ...) on each book, resources in the form of text, tape records, compact disks, digital libraries and many more, establishes a benchmark on developing a structure to control interactions with demands on digital resources; to be specific here, learning objects (Cancore, 2004).

**Objectives:** It is a type of data about data with one main difference than metadata. It presents the reason behind a learning object. To be specific here, it determines the reason behind all sub sections of a learning object: “Learning Contents”, “Practice Contents” and “Assessment Contents”.

**Content Materials:** It has been fully described on the following section, though, it has been divided into two main classifications: Types and categories of Content Materials. Briefly, types of content materials are divided into three sub-classes which are: “Learning”, “Practice and “Assessment” contents. In addition, each type has its related groups of categories of content materials known as “Scenario”, “Queries” and “Explanation”. Further details are in appendix 17.4.

#### 17.4 Content materials (CM):

Content materials are the key principle of development of any complete (fully)-deliverable-course-materials for a course, would require a properly arranged and collected form of content materials; as it is shown on the following picture Figure 81.

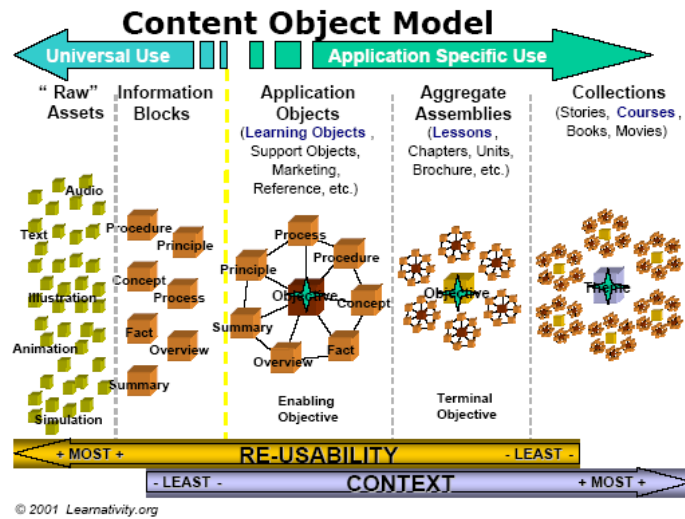


Figure 81: Content Object Model

#### 17.4.1 Types and categories of CM

Content materials in a learning object would be reviewed from two different perspectives: "Types and categories of content materials". The relationship between these concepts has been illustrated on figure 15. As shown, a learning object is a combination of matrix-based connection of different content materials in different formats. It has been grouped into two classes: (i) Types of Content Materials, and (ii) Categories of Content Materials.

##### 17.4.1.1 Types of CM:

Types of Contents Materials will classify relevant content materials of a learning object into three different learning, practice and assessment contents. Further description can be found as below:

**Learning Contents (LC):** It is a type of content material which is used for delivery of learning materials. It is a collection of digital assets within the category of scenario. Main purpose of having this type of learning contents is only to present information. No enquiry will be made during the presentation of this type of content materials. In this session, a learner will only gain what is needed to know before other sessions of evaluating his/her knowledge assessment.

**Practice Contents (PC):** Practice content type of content material is a collection of three sub-sections or categories. It is a collection of scenario, query and explanation. This section is mostly known as either practice session, Q/A session or tutorial session. A learner by going through this type of content materials will receive a short scenario then he has to answer a series of questions and get a chance to check their correct answers. At the end he should be given a chance to see the reason behind those answers of why a particular answer was correct. The whole session is known as practice materials for a given objective of related learning objects. In this session, the knowledge level of a learner will be evaluated by providing him/her with a series of questions in the format of recalling, understanding and competency levels of knowledge assessment (see section “Query” below in 17.4.1.2 for further information on Knowledge assessment).

**Assessment Contents (AC):** It is a collection of content materials in two different categories: scenario and query. Knowledge of a learner will be assessed on the base receiving a confirmation on the evaluation of his/her level of recalling, understanding and competency on that piece of knowledge. So, if the learner passed that assessment, s/he is considered as “Pass” through that level. Otherwise the learner has few other options. Either s/he has to (i) take the same learning object again and/or (ii) do other available and relevant practices or (iii) do another relevant assessment. This is a

business rule where an instructional designer needs to configure it at the beginning of designing the system. Just to clarify the matter, there will be no explanation for this session.

#### 17.4.1.2 Categories of CM:

Above mentioned types of content materials are categorised into three formats. These categories will be divided through different types of content materials mentioned in section 17.4.1.1. a better illustration of this concept has been presented on figure LO. Categories of contents materials would be:

**Scenario (S):** A section is a context in the form of a short story. This category of the content materials provides a description on giving particulars on situations, events and what is possible outcome of a process; “*An outline or model of an expected or supposed sequence of events*”. [Ref: <http://dictionary.reference.com/browse/scenario> ] This is a method which has been commonly practiced even on traditional face-to-face classes where a lecture prepares a situation and purposefully describes what happens by going through series of events. Other steps will follow when a learner enquired about the process, which are counted as other categories of content materials.

**Query (Q):** Query is known as a series of questions and answers within the category of a query. Aims of these queries must be towards evaluating objectives of the relevant scenario. Thus, query is known as a session when an evaluation of a learner’s knowledge in relation to a given scenario is under question. This would be done through checking a learner’s knowledge by evaluating his recalling, understanding and competency levels on a piece of knowledge.

**Explanation (E):** By knowing the need for a proof of why a specific answer is the correct one for a particular question, an explanation context in the form of description

to give the reason behind an answer would be categorised as explanation for to the requested query. This description, however, would include why a choice, an option or a suggestion in the Query section is accepted.

|                              |                         |                                   |                                   |                                     |
|------------------------------|-------------------------|-----------------------------------|-----------------------------------|-------------------------------------|
| <b>LO</b><br>Learning Object |                         | <b>LC</b><br>Learning<br>Contents | <b>PC</b><br>Practice<br>Contents | <b>AC</b><br>Assessment<br>Contents |
|                              | <b>S</b><br>Scenario    | <b>CM</b><br>Content<br>Material  | <b>CM</b><br>Content<br>Material  | <b>CM</b><br>Content<br>Material    |
|                              | <b>Q</b><br>Query       | ---                               | <b>CM</b><br>Content<br>Material  | <b>CM</b><br>Content<br>Material    |
|                              | <b>E</b><br>Explanation | ---                               | <b>CM</b><br>Content<br>Material  | ---                                 |

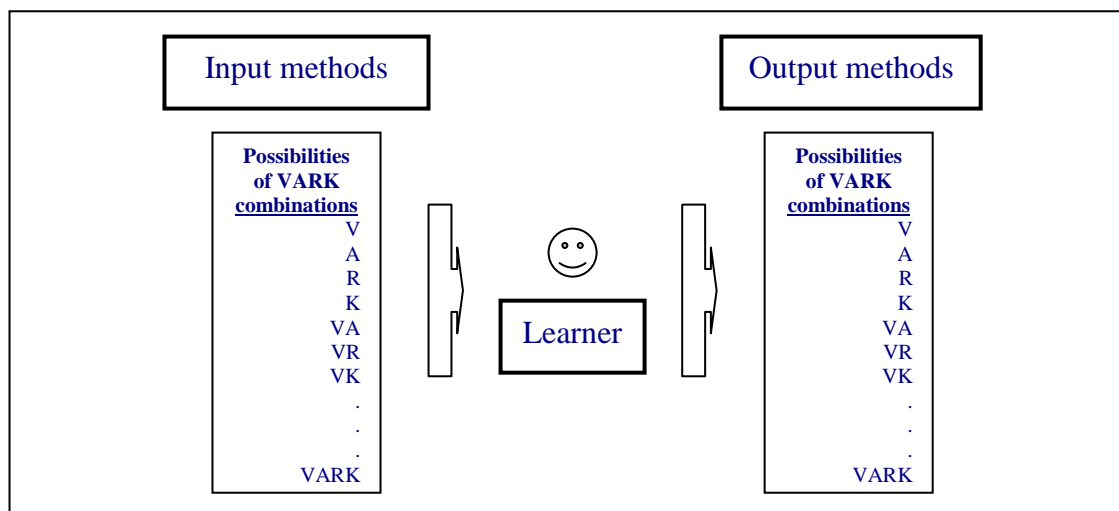
**Figure 82:** A detailed version of a semi-standard version of a learning object (LO) (Repeated in section 5.5)

#### 17.4.2 Learning Object and Human Computer Interaction Factor

On the base of Figure 82 and considering possibilities of human computer interactions (Figure 83), this would be counted as a point of reference towards having a unique and personalised form of a learning object, which would be the most compatible package on individual's learning preference and so a personalised ELS.

Studying the human-computer interaction is way beyond the scope of this study, though, briefly, HCI is referred to the study of the relationship between Human, Computer and Task in hand (Dix et al. 1998; Elsom-Cook, M., 2001). In that respect, as illustrated in Figure 82 and by the consideration of HCI (Human Computer Interaction) factor, a quick survey will illustrate the possibilities of different types of contents materials for a learning object. This would be counted as a point of reference

towards having a unique and personalised form of a learning object, which would be the most compatible package on individual's learning preference and so a personalised ELS.



**Figure 83: Possible Human-Computer interaction (HCI) – Learning Preference based**

To continue the process of analysing digital assets based on HCI, as mentioned on the Figure 83, the first step would be separating both types of contacts into User → PC and PC → User groups of interactions. In this case, theoretically, HCI allows for 30 different methods of communication between human and computer to be able to do a task [15 types of interactions of (User → PC) + 15 types of interactions of (PC → User) = 30 (User → PC → User) = 30 types of interaction of (User ↔ PC)]. But there is an issue exist on designing a procedure for developing all needed learning objects to fulfil all different types of content materials for the purpose of this study. By having an overview of Figure 83, there must be 30 different types of contents materials per each type per category or [30 (HCI-LP based CM) x 6 (CM per LO) = 180] 180 different content materials per learning object needed, so to fulfil requirements of creating one learning-preference-based learning object. This of course

would be the base of a perfectly designed and developed theoretically-based learning object for a VARK-based personalised e-learning system.

But in reality this is not a feasible approach to take the project of developing content materials for a personalised learning or e-learning system. To find a way on simplifying this process, there must be a method on finding logical similarities between different methods of creating individual DAs and then content materials; whether it is a Principle-DA or Complex-DA.

- Principle-DAs: are set of digital assets which are counted as bases of design and development of other complex digital assets and they are: V (Visual type of digital asset, like picture and animation), A (Auditory type of digital asset like a piece of sound or recorded voice of a lecturer), R (Reading type of digital asset like any text in the form of digitally typed digital asset) & K (is known as any kind of interactive digital asset which users can control those objects on the screen is another type of digital asset)
- Complex-DA: are a grouped version of Principle-Digital Assets. They have been categorised into the following type of Complex-DAs: VA, VR, VK, AR, AK, RK, VAR, VAK, VRK, ARK and VARK.

This fact shows the need for a set of regulations to allow compatibility of the process of developing digital assets with consideration of individual's learning preferences; as mentioned on this section and section 2.5.2.

### 17.5 From an expression to Digital Assets

To understand the process of creating individual or complex digital asset, there is a need to search for any relationship between concepts and processes of developing a type of Digital Asset with consideration of learning preferences.

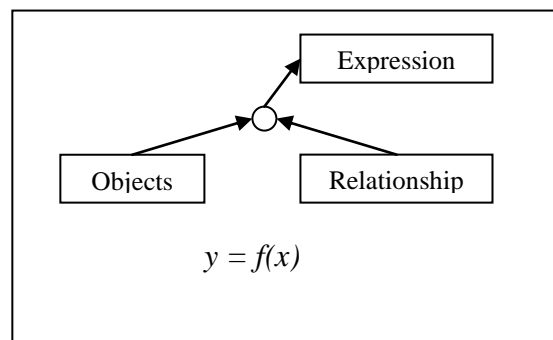


### 17.5.1 Objects, Relationship and Expression

The concept of a digital asset requires clarification of its description, objects and relationship(s) between them, since the nature of any digital asset is a combination of objects and the relationship between those objects with a particular arrangement. This arrangement could be static or dynamic or in another word, time dependent or not. The concept of expression is very similar to the known mathematical equation as follow:

$$“y = f(x)”$$

where the type of function (f) determines the relationship between variables or objects (as x) to create a new expression as y, Figure 84.

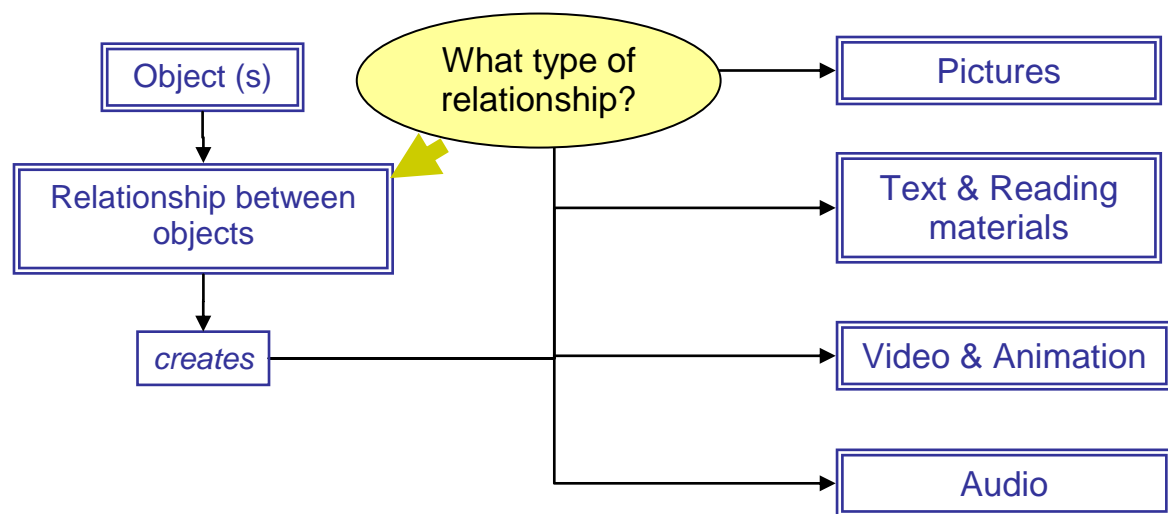


**Figure 84:** Chart for creating the concept of an expression

Now at this stage, if the process of analysing a digital asset be related to the concept of learning preferences, the approach of this analysis would be based on that learning preference. Thus, the concept of VARK based breakdown of any learner’s learning method would be real and could have a practical approach to developing a personalised version of that digital asset and so the content material.

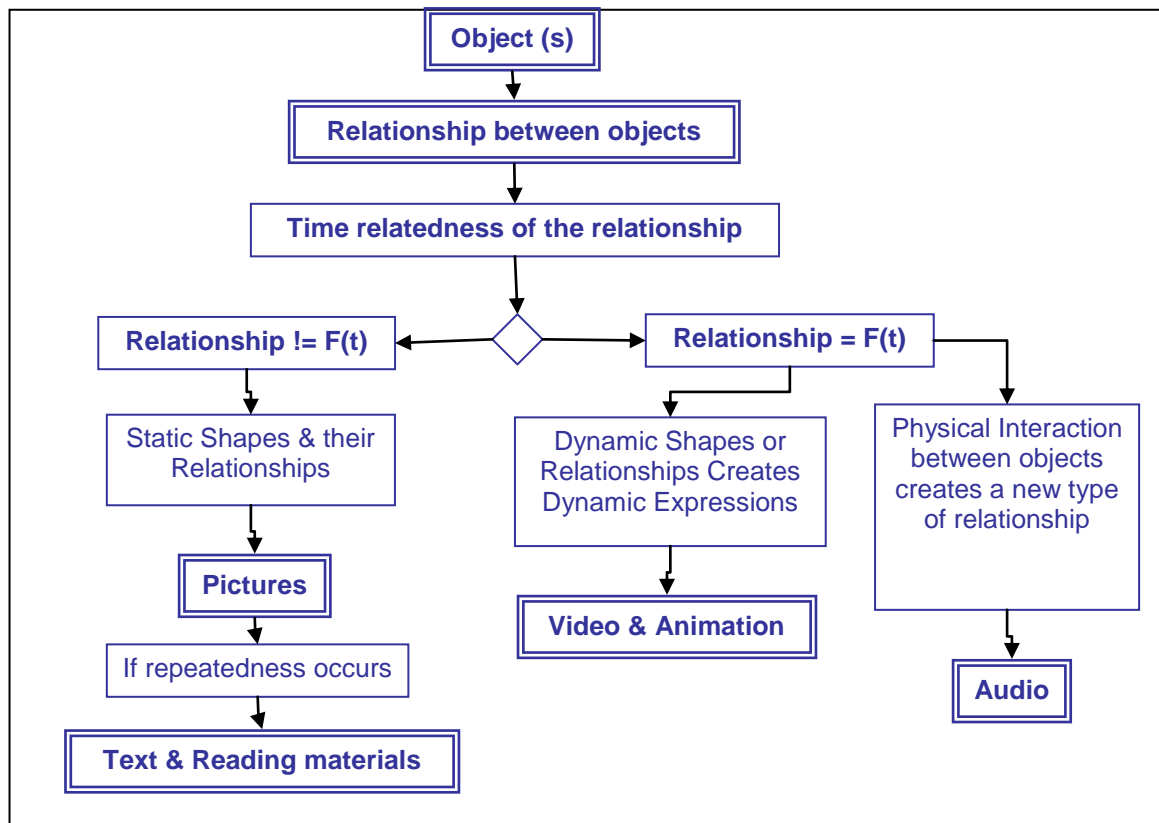
### 17.5.2 High level overview of the process of creating digital assets

In the process of creating digital assets, the relationship between those objects determines which type of digital asset will be the outcome of the process, which will have different expressions. This means the type of digital asset would be dependant on the relationship between its objects. The question here is that what type of relationship? (Figure 85)



**Figure 85:** *Simple process of creating digital assets*

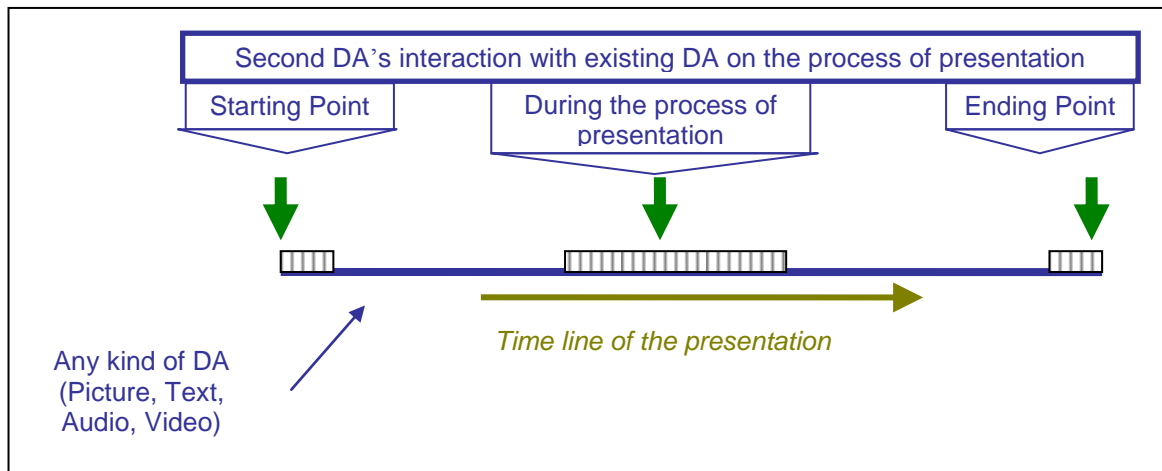
As mentioned above, the type of digital assets will be either static or dynamic, which means its creation process or the relationship between its objects will be time dependant. On the other hand, the type of interaction is also a factor, as it will be either a physical interaction between objects or not. Figure 86 clarifies the concept of relationships between objects in the best possible way.



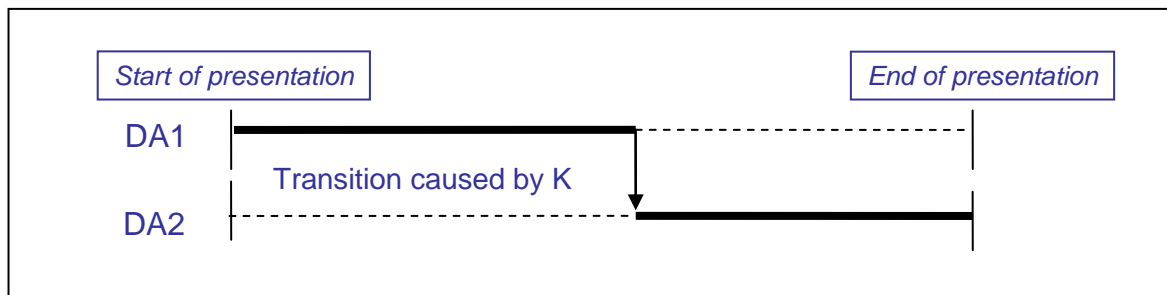
**Figure 86: Process of creating Digital Assets**

### 17.5.3 Analysis of Kinaesthetic type of interaction

In this type of learning preference (kinaesthetic), the interaction between other types of learning preferences would be studied. The Kinaesthetic type is not a type of digital asset in itself, but its effect changes the order or type of presented Digital Asset, either in the form of interaction with existing DA (Figure 87) or starting a new DA in the process (Figure 88).



**Figure 87: Kinaesthetic effect**



**Figure 88: transition of Digital Assets by Kinaesthetic effect**

By finding out the possibilities of having relationship between the concept of digital assets and a category of learning preferences, such as VARK, and finding out any connection between those two groups, a good example on Kinaesthetic mode of interaction between DAs have been brought to attention on the following section.

### **An example on the concept of using a kinaesthetic method of interaction**

To interact with a kinaesthetically developed content object, following events occur:

**Scenario:** A learner interacts with content materials by using a graphical user interface.

Details of this interaction:

- Brain receives a message in the form of either V, A or R

- Brain sends a message to the physical part of the body (mostly hand and fingers)
- Hand takes control of the mouse (as an example, or it could be the movement of the hand towards a button of the keyboard)
- Hand takes control of the mouse and points the cursor to an object on the screen (or the finger to touch a button)
- Hand (finger) makes a pause
- During this pause, brain receives the second message either in the form of V or A from the screen as cursor has touched an object (or in the form of V by seeing the touched button on the keyboard)
- Brain checks that the right object has been touched or triggered
- Then brain send the second message to the physical part of the body as a confirmed-continuation of the activity (either the finger on the mouse pushes the button, or the finger on the keyboard presses the button)
- In this case computer receives the message in the form of K, which has been done either in the form of  $K \rightarrow V$ ,  $K \rightarrow A$  or  $K \rightarrow W$ .

#### 17.5.4 LP-based-LOs and the need for a digital asset converter

Further to analysis of digital assets and finding the possibilities of relating each type of digital asset to an individual's learning style the framework was set for the design and development of a new system where it could deliver relevant learning objects. On the above sections, concepts of learning objects and its relation with individual's learning styles were studied. Process of developing a learning object also required an in depth analysis and understandings on clarifying the relationship between both learning contents and learning preferences, however, there is one issue exit, and it is

the issue of development phase of content materials for each learning object. As in 17.4.2 has been mentioned that theoretically 180 different of contents materials needed to complete one learning object. But this is not an efficient method to approach not only through the design and development phase of digital assets but also the system which would dynamically generate learning objects. This has given a ground work for to work with for the design of a new switchboard which would simplify this process.

#### 17.6 Conclusion of this chapter

In this chapter, concepts of Knowledge, Knowledge Management, Knowledge Transferring & Learning Systems, Learning Styles, and Psychological and Physiological factors of a learner were studied. The above sections have provided a benchmark to analyse what is involved in the process of designing an e-learning system. Needs for expanding the field of knowledge, knowledge management, knowledge transferring environment, known as teaching and learning environments, have been reviewed. In addition to that, needs and opportunity to create and develop an environment for the purpose of knowledge transferring in the form of a learning environment were discussed. The concept of strategic-knowledge was evaluated so as to give an understanding of the concept of personalisation of any knowledge transferring system. Different learning philosophies and individual's learning styles were also investigated to help define the scope of this research.

The current chapter has investigated the philosophical concepts and needs for a learning environment. The following chapter will review such needs from technical side.

## **Appendix 18 Set of roles on designing a collaborative learning environment**

Chi et al. (1989), McCalla (1990) and Baker (1991) have found and supported that explanations emphasize learning, especially if the approach has taken into account a collaborative environment. This environment should include:

- **Decomposing:** splitting each set of problems into different sets of given task that creates logical sub-unit of the given problem. Each individual task can be further divided into a number of goals or “Learning Objectives”, where a list of goals consists of a set of tasks. In that respect the newly designed AAPELS should include decomposing approach while transferring the knowledge.
- **Defining:** refers to recommending a goal from a task or a task stated to the goal can define goals. List of objectives in each learning object would fulfil this requirement.
- **Critiquing:** refers to questioning a hypothesis proposed by a peer learner with an alternative hypothesis. As this is not a fully designed collaborative ELS, then this method will not be included in the design process.
- **Convincing:** is an act of evaluating a number of hypotheses and supporting one of them. Although this method is mainly aimed for a collaborative online learning environment, the practice section of each learning object would perform this method by convincing the learner on different aspects of using learning object’s objective.
- **Reviewing:** is where collaborative learning ensures that constructive learning has happened. It can be done by reviewing summaries of actions taken in the

collaborative session for a particular goal. Similar to “convincing” method, this method also is mainly related to a collaborative area, though, the answer and explanation sections to practice category of learning objects would fulfil requirements of this method.

- **Referencing:** refers to the act of providing facts and related materials, whenever requested by a peer. This part of method will not be included on this version of the e-learning under research as this research is about studying the relationship between individual’s learning styles and possible connection with his/her learning performance.

## Index

|                        |          |  |                                       |
|------------------------|----------|--|---------------------------------------|
|                        | <b>E</b> |  | <b>T</b>                              |
| E-learning, 2          |          |  | traditional WBT development model, 53 |
|                        | <b>H</b> |  | <b>W</b>                              |
| <b>Hypothesis</b> , 3  |          |  | web-based training (WBT), 2           |
|                        | <b>L</b> |  |                                       |
| Learning Objects, 11-4 |          |  |                                       |