

Author's Accepted Manuscript

Performance of the mission critical Electrical Support System (ESS) which handled communications and data transfer between the Rosetta Orbiter and its Lander Philae while en route to and at comet 67P/Churyumov-Gerasimenko

Susan McKenna-Lawlor, Peter Rusznyak, Jan Balaz, Walter Schmidt, Cinzia Fantinati, Oliver Kuechemann, Koen Geurts

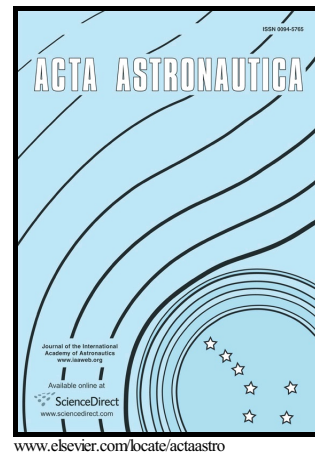

PII: S0094-5765(15)00460-9
DOI: <http://dx.doi.org/10.1016/j.actaastro.2015.12.015>
Reference: AA5636

To appear in: *Acta Astronautica*

Received date: 6 October 2015
Revised date: 9 December 2015
Accepted date: 16 December 2015

Cite this article as: Susan McKenna-Lawlor, Peter Rusznyak, Jan Balaz, Walter Schmidt, Cinzia Fantinati, Oliver Kuechemann and Koen Geurts, Performance of the mission critical Electrical Support System (ESS) which handled communications and data transfer between the Rosetta Orbiter and its Lander Philae while en route to and at comet 67P/Churyumov-Gerasimenko, *Acta Astronautica*, <http://dx.doi.org/10.1016/j.actaastro.2015.12.015>

This is a PDF file of an unedited manuscript that has been accepted for publication. As a service to our customers we are providing this early version of the manuscript. The manuscript will undergo copyediting, typesetting, and review of the resulting galley proof before it is published in its final citable form. Please note that during the production process errors may be discovered which could affect the content, and all legal disclaimers that apply to the journal pertain.

Performance of the mission critical Electrical Support System (ESS) which handled communications and data transfer between the Rosetta Orbiter and its Lander Philae while en route to and at comet 67P/Churyumov-Gerasimenko

Susan McKenna-Lawlor^{1*}, Peter Ruzsnyak¹, Jan Balaz^{1,4}, Walter Schmidt², Cinzia Fantinati³, Oliver Kuechemann³ and Koen Geurts³

1. Space Technology Ireland Ltd., Maynooth, Co. Kildare, Ireland.
2. Finnish Meteorological Institute, Erik Palménin aukio 1, P.O. Box 503, FI-00101 Helsinki, Finland.
3. German Aerospace Centre (DLR), Microgravity User Support Centre (MUSC), Cologne, Germany.
4. Institute of Experimental Physics, Slovak Academy of Sciences, Watsonova 47, Kosice, Slovakia

* Corresponding author. Tel.: +353-1-628 6788; Fax: +353-1-628 6470; Email: stil@nuim.ie

Abstract: *The Electrical Support System (ESS), which was designed and built in Ireland, handled commands transmitted from the Rosetta spacecraft to the Command and Data Management System (CDMS) aboard its Lander Philae during a ten year Cruise Phase to comet 67P/Churyumov-Gerasimenko as well as at the comet itself. The busy Cruise Phase included three Earth flybys, a flyby of Mars and visits to two asteroids, Steins and Lutetia. Data originating at the individual Lander experiments measured while en-route to and at the comet were also handled by the ESS which received and reformatted them prior to their transmission by Rosetta to Earth. Since the success of the Lander depended on the acquisition of scientific data, the ESS was defined by the European Space Agency to be Mission Critical Hardware. The electronic design of the ESS and its method of handling communications between the spacecraft and Philae are herein presented. The nominal performance of the ESS during the Cruise Phase and in the course of subsequent surface campaigns is described and the successful fulfilment of the brief of this subsystem to retrieve unique scientific data measured by the instruments of the Philae Lander demonstrated.*

Key words: Rosetta; Philae; ESS; Electronic design; Telecommunications; Cometary data.

1 Introduction

In the aftermath of Ireland's first experiment on an ESA spacecraft (the energetic particle detector EPONA on the Giotto Mission to Halley's Comet), Dr. Helmut Rosenbauer, then a director of the *Max Planck Institut für Aeronomie* (MPAe) at Lindau, Germany and designer of the Rosetta Lander Philae, invited the EPONA PI Susan McKenna-Lawlor (SMcKL) in her capacity of owner/director of the Irish high-technology company *Space Technology Ireland Ltd.* (STIL) to take responsibility for designing/constructing/testing/delivering the *Electrical Support System* (ESS) for the Rosetta Mission to comet 67P/Churyumov-Gerasimenko (67P/C-G). For overviews of this mission see Bibring et al., 1997 and Glassmeier et al., 1997.

This was a highly responsible commission. The ESS was tasked to support the *Mechanical Support System* (MSS) in providing for the release of the Lander (Philae) from the Rosetta spacecraft and its deployment onto the surface of 67P/C-G. In addition, commands from the spacecraft to the ten individual experiments aboard Philae during planetary and asteroid flybys during the Cruise Phase and in the course of subsequent surface science

campaigns at the comet, were to be handled by the ESS. Further, data transmitted to Rosetta from Philae would be received and suitably stored by the ESS prior to their transmission to Earth by the spacecraft. Since the success of the Lander directly depended on the successful acquisition of science data, the ESS was defined by ESA to constitute *Mission Critical Hardware*.

In the present paper an overview of the specification of the ESS initially issued by ESA is provided for background reference in Appendix A. Section 2 presents circumstances attending the construction in Ireland of the ESS. Section 3 describes the general design and function of the ESS and its interaction with other related subsystems. Section 4 summarises the software implementation in the ESS and Section 5 the hardware electronic design of the ESS Processor developed as a solution to ESS requirements. Section 6 outlines how communications between the ESS and the Lander instruments were implemented. Section 7 contains an overview of the operations phase and Section 8 provides an account of: the performance of the ESS during: the cruise phase of the mission and in support of subsequent surface related activities. Finally Section 9 contains general conclusions.

This is the first paper to be published that describes the ESS. Other information is contained in technical and administrative documents not in the public domain. These include three major Experiment Interface Documents (EIDs): The EID-A describes interface requirements from the ESA Project to the Lander teams; EID-B describes the interface requirements from the experiments to the spacecraft. EID-C reflects baseline requirements for on-board electrical functional interfaces. These requirements were updated following an ESA System Requirements Review (1997) and an ESA System Design Review (1998). See also Rosetta Lander, System Specification (June 1998) and The Rosetta Lander USER Manual (August 2003). Over the ten year Cruise Phase from 2004 reports that contain mention of developmental matters related to the ESS are contained in the Minutes of the Rosetta Lander Progress Meetings and in the Minutes of the Steering Board of the Lander.

2 ESS implementation in Ireland

The construction and electrical testing of the ESS electronics took place at *Space Technology Ireland Ltd.* (STIL) within a Class 100 Clean Room. Visits from ESTEC engineers were frequently made (a) to ensure that ongoing construction was implemented according to strict ESA protocols; (b) to conduct necessary instrument Design Reviews and (c) to take custody of voluminous technical documentation required to accompany the delivery of individual models. The philosophy for the ESS was to provide a Thermal Model, Structural Model, Engineering Model, Flight Model and Flight Spare. Necessary environmental testing was carried out using facilities available at the *Max Planck Institut für Aeronomie* (MPAe), Germany and at ESA's *European Space Research and Technology Centre* (ESTEC) at Noordwijk, Holland. Later, three 'ground reference' models were provided by STL to the *Deutsches Zentrum für Luft und Raumfahrt* (DLR) at Cologne to support post-launch activities. The embedded software was written in Ireland by Captec of Malahide according to ESA protocols and the Captec engineers carried out integration activities at STIL.

In view of the ten year long Cruise Phase of Rosetta to 67P/C-G, it was foreseen by ESA that, by the time Philae would be delivered to the comet, the technology adopted in building the ESS would be outdated and might even be unfamiliar to new generations of engineers. It was thus required that the STIL Instrument Manager P. Ruznyak be retained on stand-by throughout the Cruise, Landing and On-Comet phases under the terms of an ESA 'Knowledge Management Program' so that he could be called upon to provide advice on any unforeseen problems that might arise over the years. In the event he was never called upon to intervene

due to the ongoing nominal performance of the ESS. Meanwhile, SMcKL who, during the construction period of the ESS provided not only regular technical briefings to ESA on the status of the ESS but also ongoing information on its progress to the *Steering Board* (SB) of the Lander, continued throughout the Mission as Ireland's representative on this Steering Board.

General funding for the ESS was made available to STIL through ESA's PRODEX Programme (*PROgramme de Développement d'Expériences scientifiques*). In the circumstance that the mission critical status of the design called for radiation hard components with long procurement times and very elevated prices, ESTEC and MP Ae provided many electronic items from their stores for the ESS. Also, the then state-of-the-art rad-hard *Field-Programmable Gate Arrays* (FPGAs) were procured by the *Centre national d'études spatiales* (CNS) at Toulouse through the good offices of SB member Dr. D. Moura. These items were, thereafter, taken by SMcKL to Germany where burning-in of the ESS program was implemented at the *Deutsches Zentrum für Luft und Raumfahrt* (DLR) at Berlin. Ultimately, since rad-hard ROM chips fell under the auspices of the *International Traffic in Arms Regulations* (ITAR) regulations, when the time came to close the Flight Model, a politically empowered engineer was sent from the United States to solder in this component and seal the box.

3 Design and Function of the ESS Processor

3.1 Top-level Functional Block Diagram

As can be seen in the block diagram presented in Figure 1, the ESS Processor Unit has a central role in interfacing between the Rosetta Orbiter Spacecraft and the various Lander Subsystems. The units involved are as follows:

Orbiter side:

- Data Management System (DMS)
- Power Distribution System (PDS)
- Mechanical Support System (MSS)

Lander side:

- Command and Data Management System (CDMS)
- Telecom Subsystem (Tx/Rx) including antennas
- Lander Power Distribution Subsystem (LPDS)
- Lander Thermal Control Subsystem (LTCS)

It is noted that the Power Subsystems are not shown in the functional block diagram.

The ESS decodes, verifies and executes telecommands (TCs) addressed to the ESS itself, the ESS-Tx/Rx system, the MSS and to Philae while it is still attached to the Orbiter. Commands addressed to the Lander units are wrapped in a transfer frame and forwarded (via the umbilical or RF link) to the CDMS which manages the Lander subsystems and the payload instruments. Data originating at the individual Lander experiments are also handled by the ESS which receives and reformats them prior to their transmission by Rosetta to Earth.

3.2 Redundancy Concept

As a Lander subsystem of prime importance, the ESS is built in a fully redundant configuration. The baseline is to provide a 'cold redundant' system – one that consists of a nominal and a redundant side, with no connection between the two. The management of this

redundancy is implemented by the Orbiter *Power Distribution System* (PDS) – by switching the nominal or redundant power line “ON” it selects the nominal or redundant ESS side.

In certain cases a more complex redundancy management is utilized, due to the internal operation of the Lander. As a prime example, the lander *Command and Data Management System* (CDMS) has its own intelligent redundancy management scheme – to be compliant with this, both of the ESS sides are able to communicate with both CDMS sides. This means that this communication is totally transparent to the ESS SW – actually the ESS does not even need to know which side of the CDMS is working. Similar redundancy management applies to the control of the WAX motors and the PUSH POWER lines in the *Mechanical Support System* (MSS) - either side of the ESS has the capability to switch on/off both the WAX motors and PUSH POWER lines.

In most instances the ESS Processor Unit forms a direct chain with other Orbiter and Lander Subsystems: the nominal ESS side can only work with: the nominal Tx/Rx unit; with the nominal *Remote Terminal Unit* (RTU) of Rosetta’s *On Board Data Handling* (OBDH) system, etc.

The description of the redundancy management of the *Lander Thermal Control Subsystem* (LTCS) is beyond the scope of this paper – the ESS simply routes the associated power lines to the LTCS. Refer to Figure 2 for a schematic of the Redundancy Concept of the ESS Processor Unit.

3.3 Detailed functional block diagram

A detailed functional block diagram of the ESS Processor showing one of its double-redundant units is provided in Figure 3. The unit includes the *Central Processor Unit* (CPU) based on the 16-bit processor 80C86 operating with $32k \times 16$ PROM and $128k \times 16$ RAM memory. The CPU includes: the System Controller; the *Direct Memory Access* (DMA) controller, Interrupt Controllers; Address Multiplexer; Task Timer; Watchdog; *Non-Maskable Interrupt* (NMI) circuitry; and an external Clock Generator. The interfaces are described in detail in the following sub-sections.

3.4 Data Management System (DMS) interface

This hardware (HW) interface is based on the recommended circuitry in *Experiment Interface Document* EID-A. See Section 2.7, page 49, Figure 2.7.4-6, for the *Memory Load* (ML) interface and the *Telemetry Data* (TM Data Acquisition) interface. The data transfer protocol is supported in HW by two 8 kword DMA buffers as shown in Figure 4 which presents block diagrams of the Memory Load Interface (left) and the TM Data Acquisition interface (right).

The size of the TC DMA (Direct Memory Access) Buffer ensures that a large number of telecommands can be stored here while waiting for processing (from min. 30 TCs up to several hundred TCs, depending on their length). This buffer performs as a circular buffer. The TC processing rate of the ESS software is one per 100 msec – the user must ensure that the buffer does not overflow under these conditions.

The size of the TM (telemetry) DMA Buffer ensures that a maximum size TM block (6144 words) can be read out autonomously by the DMS without SW interaction in the ESS. The process of the TM block transfer is transparent to the SW. This buffer is used as a straight buffer and it is re-written with the next block after the readout is completed.

The ESS supports the Time Synchronisation Service provided by the DMS. The block diagram of the Time Synchronisation interface is shown in Figure 5.

3.5 *Telecom Subsystem Interface*

The interface to the Telecom Subsystem (Tx/Rx units) consists of a, bi-directional, bit synchronous 8 bit communication link (balanced line) for TC data exchange and a, bi-directional, asynchronous 8 bit link (balanced line) for housekeeping (HK) - collection/commanding of the Tx/Rx units. It is important to note that there is no cross coupling provided for RF communication – the nominal ESS works with the nominal Tx/Rx, the redundant ESS works with the redundant Tx/Rx only. See also Section 3.10. Two co-axial relays are used to select which chain is active (one for the receiver and one for the transmitter) – switching these relays is done automatically on powering up the ESS. The status of these relays can be checked in the ESS HK packet (Word 30, bits 5 and 6, refer to the SW User’s Manual).

The ESS hardware provides extensive support for the SW implementation of the Request-To-Send (RTS) protocol (as defined in document ROS-SP-LCOM-ETAN-587-CNES) in terms of pattern recognition logic and various interrupts, as shown in Figure 6.

The HK interface is used for collecting HK data from the Tx/Rx units and to command these units into various modes (based on commands received from ground). Due to the strict timing requirements imposed by the Tx/Rx units, this communication link must be interrupt driven. The ESS uses two dedicated *Universal Asynchronous Receiver/Transmitter* (UARTs) to perform this function (one for the Rx and one for the Tx unit). A detailed block diagram of this interface is shown in Figure 7.

3.6 *The Mechanical Support System (MSS) interface*

Control of the MSS by the ESS is implemented in two distinct ways. There are certain functions that are performed by the ESS – such as WAX heater switching, Push Power On/Off and generating the Eject Signal, while other functions are executed by the MSS on receipt of a command from the ESS via its, dedicated, bi-directional bit-synchronous (16 bit) opto-isolated serial interface. A detailed block diagram of this interface is shown in Figure 8.

The Mechanical Support System is in charge of the ejection of the Lander. This is a non-intelligent unit, controlled by the ESS. Certain functions in relation to the ejection are executed in the ESS, while other functions are executed in the MSS on command from the ESS.

The following functions are executed in the ESS:

- **Switching of the MSS.** The MSS is powered from the *Latching Current Limiter* (LCL1) line. Only one side is powered at any given time. There is no HW limitation in the ESS to switch the MSS On or Off at any time.
- **Switching of the Push Power line.** The Push Power lines (nominal and redundant) are derived from the LCL3 and LCL4 lines (as shown in Figure 9). It is assumed that both the nominal and redundant lines are activated by the Orbiter spacecraft in parallel. The ESS switches all lines in parallel and the nominal and redundant input lines are made common by high current Schottky diodes. As a result, both MSS Motor Control circuits can be powered independently of which ESS side is On (transparent cross-coupling).
- **Switching of the WAX actuators.** The WAX actuators (nominal and redundant) are powered from the Push Power line in order to make more power available from the LCL1 line for other purposes. It is therefore necessary to switch the Push Power line 'On' before the actuators can be heated. The relays that are switching the WAX actuator power lines 'On' need to be enabled by setting the 'Arm WAX' line (internal ESS signal) – this is

intended to provide additional security in the operation of the WAX actuators. This way a single point error (e.g. a shorted relay driver transistor) will not necessarily cause the WAX to heat. In accordance with an attached PD scheme both ESS sides (nominal and redundant) can operate both WAX heaters. There is only one difference between the two ESS sides: the nominal side will take power for heating the WAX from the ‘Push Power nominal’ line (derived from LCL 3), while the redundant ESS side will use the ‘Push Power redundant’ line (derived from LCL 4) for this purpose.

It is especially noted that, at Lander deposition, while the ESS sent the separation command, the push off itself was performed by the MSS.

3.7 The Command and Data Management Subsystem (CDMS) Interface

The CDMS interface is based on opto-isolated bit-synchronous bi-directional serial data/command lines. As already mentioned, transparent cross-coupling is employed to ensure that both ESS sides can communicate with either of the CDMS sides. The driver circuitry that accomplishes this function in the ESS is shown in Figure 9. It can be seen that both ESS sides drive both the nominal and the redundant outputs in parallel. It is noted that identical driver circuits are applied to each output signal (Data Out, Data Out return, Data Clock Out and Data Clock Out return).

The receiver circuit is based on 4N55 rad-tolerant optocouplers (~ 19 mA current loop). The optocoupler connected to the nominal CDMS output provides signal for the nominal ESS while the optocoupler connected to the redundant CDMS output provides signal for the redundant ESS. Cross coupling is provided by both CDMS sides driving both nominal and redundant ESS inputs in parallel.

It is pointed out that the same RTS protocol applies for the Umbilical communication as that for the RF communication. A flag inside the ESS IF FPGA selects which is the actual direction of the data flow. It is important to pre-select this flag before starting the link establishment. Any signal present on the de-selected inputs is ignored. The de-selected outputs remain inactive during the entire session.

This means that the same internal logic handles the communication via the Umbilical as that utilized for the Tx/Rx, including memory buffers and pattern recognition. The only difference is the different driver stage adopted (shown in Figure 9) in place of the RS 485 line drivers.

3.8 Power Distribution System (PDS)

The ESS Controller Unit is responsible for distributing power within the Lander, while the Lander is attached to the Orbiter. As such, it receives Primary Power and Keep Alive lines from the Orbiter PDS, and – after internal switching /limiting – it provides the necessary power lines for the Lander subsystems.

It should be noted that, due to the complexity of the Lander System, each subsystem requires different handling by the ESS. In the following paragraphs detailed descriptions of the ESS power related functions for each Lander subsystem are presented.

Figure 10 provides an overview of the ESS-Lander Power Distribution Scheme

3.9 Generation of the Eject Signal.

The ESS is configured to generate a precisely timed low-to-high transition on this line to initiate the ejection of the Lander. Before ejection can be accomplished, the Push Power lines

need to be switched on and the Push Enable bit needs to be set in the MSS. There is a built-in protection mechanism for the generation of this signal in the ESS. If the Push Power is 'On' the generation of the Eject Signal needs to be 'armed' by issuing a specific internal command prior to the command that actually generates the Eject Signal. The intention at the HW design stage was to 'arm' the ejection by a specific Ground Command to ensure that a crashed SW could not generate a false ejection. This function is supported in HW but not utilized in the final version (V2f4) of the software.

3.10 The Telecom Subsystem (Tx/Rx)

The ESS provides switched primary power for the Telecom Units. The nominal ESS provides power for the nominal Telecom Units while the redundant ESS provides power for the redundant Telecom Units (no cross coupling). The Rx and Tx units are switched in parallel (by the two contacts of a single relay) but have separate latching power limiters. These limiters are set to ~ 200 mA @ 28 V (~ 6 W) for the Rx unit and to ~ 400 mA @ 28 V (~ 12 W) for the Tx unit. There is no limitation in the ESS HW to switching the Tx/Rx units On or Off at any time.

The ESS also provides a switching signal for the Co-axial Relays that switches the Tx/Rx antennas to the unit that is actually working. The Co-axial Relays are bi-stable devices, requiring only a short pulse to accomplish the switch-over. This function is done automatically at power 'On' – the nominal ESS will provide a switching pulse on the Rx and Tx Command Nominal lines while the redundant ESS does the same on the Rx and Tx Command Redundant lines at power on. The duration of the switching pulse is approximately 15 msec.

3.11 Command & Data Management System (CDMS)

The only power distribution related function here is the Keep Alive Line – the ESS routes through the 'KAL 1' line to the CDMS via the Umbilical. There is no connection made to this line inside the ESS. However, it is important to note that the associated return line is connected to LCL1 return inside the ESS.

3.12 Lander Thermal Control Subsystem (LTCS)

The only power distribution related function here is the Heater Power line – the ESS routes through the 'LCL 2' line (and its return line) to the TCS. There is no connection made to this line (or to its return line) inside the ESS.

3.13 Lander Power Distribution Subsystem (LPDS)

The ESS provides primary power for the Lander. This line is provided from the LCL 1 line, via a latching power limiter. This limiter is set to ~ 1.8 A @ 28 V (~ 50 W). There is no switch incorporated. The ESS limits the output power – this means slightly more current at lower and slightly less current at higher LCL1 voltages. Nevertheless, as long as the incoming voltage is within specification ($\pm 1\%$), this function has no real relevance.

3.14 ESS Internal Power

The ESS uses two Interpoint SMSA converters for generating + 5 V, + 12 V and – 12 V for its internal operations. An FMSA input filter is provided for these converters to reduce EMI effects.

4 ESS Software

4.1 Overview

The largest part of the ESS software was written in C-language. However, some parts were directly written in assembler for the 8086 processor target to optimize its performance (e.g. in respect of interrupt handlers and some time consuming routines which were to be called on often during regular operations). As the SW was developed and tested on a 'PC' target, the toolset used during development was the 'Microsoft Visual C++ V1.5.2' which at that time was the 'standard' development tool used to generate 16-bit code for any PC running MS-DOS.

When modifications to the original SW were called for post launch, a dedicated software was developed by O. Knechemann to extend the functionality of the existing tool-chain in order to automatically apply modifications to the SW running from PROM.

4.2 Operation System

The unique operation system was written especially for the ESS. It executes the tasks which define the ESS software using a round-robin scheduling mechanism based on the system provided, 10ms real time clock interrupt. *Normal Frequency (NF)* tasks are executed with a period of 100ms, while *Very High Frequency (VHF)* tasks operated at 10ms periodicity are used to collect the ESS HK. *Ultra High Frequency (UHF)* tasks are operated at 1ms period and triggered directly by Tx/Rx interrupts.

The operation system allows tasks to be characterized by three parameters: Period, Phase and Priority. Task switching is achieved by a Dispatcher Routine which runs in an endless loop once the system has booted. The software is grouped in 13 tasks, which are executed by the Dispatcher. Figure 11 shows the schematics of tasking within the ESS SW. A software functional overview (the communication between tasks) is shown in Figure 12.

Not all tasks are included; the missing ones provide low-level functionality to the top-most tasks. In this context it is noted that the ESS SW provides a functionality (SAT) to release a set of commands at given times, which was used for instance to execute the pre-programmed separation sequence Orbiter/Lander.

4.3 Recovery from a possible software crash

The well-established mechanism to react to SW crashes which would otherwise render the system unusable is provided by a hardware "watch-dog" circuit. The software resets the 'watch-dog' at given intervals to prevent a hardware reset of the ESS.

5 Hardware implementation of the ESS Processor

5.1 Component Selection

The Rosetta Electrical Support System Processor Unit achieves high reliability through: the Hi-Rel parts used in its construction; the high technological working standards adopted and its redundant architecture. Careful balancing between the above drivers was employed during the design phase.

Radiation hardened components were used throughout the manufacturing of the ESS. In this context, a Rad-hard HARRIS 80C86RH processor was selected along with an ACTEL RH1280CQFP172 programmable gate array, a UTMC UT28F256 ROM memory, a Temic

M65608 RAM memory with a minimum of external passive, SSI and MSI components. All items were of the highest available quality grade.

High quality double layer PCBs were used, in order to avoid any potential problems associated with the use of multi-layer PCBs. Redundant internal wiring was implemented to make the interconnections between the six PCBs (2×3 PCBs for the two redundant sides) on which the ESS was built. Rigorous quality assurance procedures were employed to ensure adequate quality of the manufacturing, including hand soldering, and assembly.

All this resulted in a robust and very high reliability hardware, the performance of which remained nominal throughout the entire mission, thereby supporting the Lander science objectives in a successful manner (see below).

5.2 *Physical implementation*

Physically, the nominal ESS unit consists of three pc-boards, the Central Processor Unit (CPU), the Power Distribution unit (PD) and the Interface Unit (IF). Another three identical pc-boards create the cold redundancy unit. The two-layer pc-boards are made from FR4 material; their size is $139 \text{ mm} \times 139 \text{ mm} \times 1.5 \text{ mm}$ with 8 supporting spacers for mechanical rigidity. The mounting of the electronic components involved classical ‘through-hole’ technology, except for the FPGAs in their CQFP172 packages and the HS-26C31RH and HS-26C32RH interface chips that came in flat-pack ceramic carriers and were installed by surface-mount technology (SMT). Figure 13 provides a view of a full set of ESS pc-boards during the population process and Figure 14 shows the ESS Processor unit under integration in STIL’s Class 100 Clean room.

The 6-board stack was enclosed in an aluminium alloy box with four fixing lugs and with the interface connectors on two sides. The box was blackened on both its internal and external surfaces for optimal thermal radiation exchange. Figure 15 shows the completed ESS Processor during a vibration test.

6 **Communications between the ESS and the Lander**

6.1 *Design principles*

As seen from the Rosetta spacecraft, the ESS implements the data interface toward Philae. It accepts standard telecommands formatted according to the CCSDS (Consultative Committee for Space Data) protocol, interprets them, and then either executes them locally inside the ESS or reformats them according to the ESS-Philae-CDMS communication protocol and sends them to the CDMS either via the umbilical line (before Lander separation) or via the radio link of the Tx/Rx subsystem thereafter. Telemetry packets received from the CDMS via the umbilical line or the Tx/Rx subsystem are reformatted into CCSDS compatible packet formats and sent onwards to the Rosetta on-board computer. Additionally, the ESS sends housekeeping packets that provide the status of the ESS itself and of the link to the CDMS while also responding to special reconfiguration and information retrieval requests. The interface towards the CDMS can be selected via commands to be either the wired connection via the umbilical line or the radio link via the Tx/Rx subsystem even while Philae is still attached to the spacecraft, thereby allowing the verification of the radio equipment before separation. The details of the communication protocol are in both cases the same.

6.2 *Link establishment*

The overriding design principle for the communication link design was: a high degree of autonomy for establishing links, correcting data transmission errors and recovering a link if it got interrupted. Nevertheless, most autonomous functions can be overwritten by ground commands if needed. Link establishment through the cable is straight forward, giving instantaneous access to all functions of the CDMS. The establishment of a radio link is more complex and contains several safety options to maximize the possibility of a link. When started by command from the spacecraft, the Tx/Rx subsystem is switched on and its transmitter is activated with a carrier frequency in the S-band, defined inside a configuration register of the Tx/Rx subsystem as 2208 MHz. A hailing signal is sent on this carrier allowing the receiver decoding circuitry in Philae to recognize a valid incoming signal. At the same time the radio system's receiver starts scanning around the defined receiver frequency of 2033.2 MHz looking for a Philae transmitter signal to lock on to. If it is suspected that the Philae carrier frequency has drifted outside the searched range, the central frequency in the Tx/Rx subsystem can be changed by command. Once the receiver has locked on to the carrier, the detected frequency is stored inside a Tx/Rx register and can be read by command to the ESS.

After the Philae CDMS is powered it starts listening on the umbilical line or, if disconnected, it powers up one or both of the redundant receivers (depending on the configuration settings), and monitors the output of the receivers. Once the hailing code is recognized by the receiver decoding circuit, the information of a valid receiver link is sent to the CDMS. The CDMS responds by powering a transmitter and sending an acknowledge message. Once this is successfully received by the ESS, the bi-directional link is considered to be established. Commands possibly already queued inside the ESS are then transmitted, otherwise a stream of placeholder patterns is sent from both sides to keep the link active without link breaks. One of the first commands expected from the ESS comprises timing information synchronized with the Rosetta on-board computer time to update the CDMS-internal clock used to time stamp all subsequent Philae telemetry packets and to control the execution of scheduled commands.

6.3 Commanding Philae

The ESS has two different ways of sending commands to the CDMS via one of the physical links. In the nominal case it verifies that a bi-directional link is established. It then addresses the CDMS processors and sends a command which is acknowledged by the CDMS via a return packet. If the checksum of the received command was incorrect a resending is requested.

If no bi-directional link can be established the ESS offers an alternative way of sending commands. The *Telecommand Backup Mode* provides a hardware buffer which can be filled with a series of commands. When activated, the contents are sequentially sent to the transmitter, even if the receiver was not able to lock on to radio signals from Philae. The same buffer contents are repeated every 32 seconds until stopped by a command from the spacecraft or when a bi-directional link is established. This allows sending of re-configuration commands to the CDMS in case the nominal configuration does not lead to automatic link establishment. To increase the probability of success, although without the possibility of verification, many safeguards inside the CDMS are bypassed: The automatic toggling between the two alternative transmitters is disabled which normally should increase the possibility for the Rosetta-side receiver to lock on to the signal. Received commands are immediately executed without context verification to allow overwriting of anomalous configurations (although this might increase the probability of a crash of the CDMS software). Any command recognized by the CDMS can be sent in this way, including software patches. Also in this emergency mode the

Rosetta-side Tx/Rx subsystem receiver is trying to lock on to a carrier, possibly sent from Philae. If successful so that a bi-directional link is established, the ESS automatically terminates the backup mode and continues with nominal link maintenance.

6.4 Telemetry consistency control

During nominal bi-directional link times, any package from the ESS to the CDMS or from the CDMS to the ESS is acknowledged after the included checksum is verified. Each packet is preceded by a 32-bit packet synchronization marker (0x1ACF, 0xFC1D) followed by a series of 16-bit words. For normal science or housekeeping telemetry sent by the CDMS, the length and structure of the packets is fixed. A header of 9 words is followed by a 128-word data packet, followed by a *Data Error Correction Word* (DECW) which is generated inside the CDMS. The DECW remains with the data packet all the way to Earth to guarantee data integrity. During the sending of the TM-words a *Cyclic Redundancy Code* (CRC) according to ESA PSS-04-107 is generated from the transmitted data stream and appended to the end of the packet. If the CRC value calculated by the ESS from the received TM-packet words matches the CRC word following the packet, the CRC is stripped, the package is re-formatted according to the Rosetta on-board protocol and sent to the mass memory of the Rosetta on-board computer for later downlink to Earth. If the checksum generated inside the ESS does not match the checksum word following the packet, a resending is requested while the next packet is being received. In this case the CDMS completes the currently sent packet, then re-sends the previously discarded packet and continues from there. If the data are directly dumped from the Philae mass memory, the mass memory's internal controller autonomously handles this error correction activity. Additional to the CDMS-generated DECW and the packet CRC, each 16-bit word is protected inside the CDMS mass memory by a 6-bit Hamming code which is used at data retrieval to automatically correct single-bit errors before the CRC algorithm is applied. If the packet checksum is not immediately followed by the first bit of the synchronization double-word of the next telemetry packet, a link break situation is assumed and a new synchronization process is initiated.

7 Operations

Since any pre-separation Lander activation could only be achieved through a switch-on and operation of the ESS unit, this action automatically allowed a check-out of the ESS unit status. The Operations Team ensured that the total amount of operational hours from launch up to the end of the mission would not exceed the guaranteed operational lifetime of the ESS and this required activity sharing between the main and redundant sides.

Between launch on 2 March 2004 and the final checkout activity before the *Deep Space Hibernation* (DSH) phase of Rosetta (begun on 8 June 2011) the ESS unit was switched on and operated as shown in the table below.

#	Activity	Power branch	Activity Start: (UT)	Activity End: (UT)	Duration hh:mm:ss
1	NEA Release	Redundant	02.03.2004-16:25:49	02.03.2004-16:35:25	00:09:36
		Main	02.03.2004-16:38:37	02.03.2004-17:23:17	00:44:40
2	CVP-1	Redundant	12.03.2004-23:04:18	13.03.2004-00:59:30	01:55:12
		Main	13.03.2004-01:09:38	14.03.2004-23:46:26	46:36:48
		Main	14.03.2004-23:54:58	16.03.2004-05:59:14	30:04:16
		Redundant	16.03.2004-06:07:46	17.03.2004-06:59:46	24:52:00
3	CVP-2	Redundant	09.04.2004-21:36:19	15.04.2004-07:43:47	130:07:28

ACCEPTED MANUSCRIPT

#	Activity	Power branch	Activity Start: (UT)	Activity End: (UT)	Duration hh:mm:ss
4	CVP-3	Main	13.05.2004-20:38:28	21.05.2004-00:33:56	171:55:28
5	Draconide Encounter	Main	08.09.2004-04:02:22	10.09.2004-00:10:22	44:08:00
6	Consert Pointing	Main	01.10.2004-00:01:51	01.10.2004-18:37:35	18:35:44
7	CVP-4	Main	05.10.2004-18:47:11	09.10.2004-01:26:07	78:38:56
8	Earth Swingby-1	Main	01.03.2005-00:02:25	07.03.2005-23:58:09	167:55:44
9	PC0	Main	29.03.2005-19:32:33	30.03.2005-00:47:13	05:14:40
10	STCB-Update	Main	21.06.2005-09:02:11	21.06.2005-12:13:07	03:10:56
11	DPU1-Investigation	Main	23.06.2005-11:02:43	23.06.2005-11:22:59	00:20:16
12	DPU1-Troubleshooting	Main	21.09.2005-03:12:20	21.09.2005-09:19:16	06:06:56
		Main	21.09.2005-09:27:48	21.09.2005-13:52:20	04:24:32
13	PC1	Main	04.10.2005-02:44:36	04.10.2005-08:34:28	05:49:52
14	PC2	Main	07.03.2006-15:02:45	08.03.2006-00:57:57	09:55:12
15	SBC#1	Redundant	08.05.2006-22:01:58	09.05.2006-18:55:18	20:53:20
16	PC3	Main	29.08.2006-14:02:00	29.08.2006-23:57:12	09:55:12
17	PC4	Redundant	28.11.2006-16:02:33	02.12.2006-07:52:57	87:50:24
		Main	05.12.2006-17:02:17	08.12.2006-22:52:09	77:49:52
18	THC1 (MSB)	Redundant	07.01.2007-11:02:50	08.01.2007-00:37:46	13:34:56
19	LOR-2	Main	24.01.2007-20:02:34	24.01.2007-21:11:54	01:09:20
20	LOR-2 verification	Main	29.01.2007-20:02:34	29.01.2007-21:23:38	01:21:04
21	MSB	Main	22.02.2007-20:32:26	24.02.2007-23:57:14	51:54:48
		Main	25.02.2007-03:02:50	25.02.2007-14:47:54	11:45:04
22	CNT1	Main	03.05.2007-18:02:03	04.05.2007-02:27:39	08:25:36
		Redundant	04.05.2007-16:02:35	05.05.2007-02:27:39	10:25:04
23	CNT1-RR	Main	17.05.2007-05:32:12	17.05.2007-11:48:44	06:16:32
24	PC5	Main	22.05.2007-10:02:04	22.05.2007-19:24:12	09:22:08
25	PC6	Main	24.09.2007 08:02:38	26.09.2007 08:37:50	48:35:12
		Redundant	29.09.2007 12:02:38	30.09.2007 01:50:22	13:47:44
26	ESB2	Main	07.11.2007 00:02:38	13.11.2007 20:17:34	164:14:56
		Main	13.11.2007 21:46:06	20.11.2007 14:07:27	160:21:21
27	SFR	Main	24.03.2008 09:02:25	25.03.2008 00:32:33	15:30:08
28	PC8	Main	09.07.2008 20:02:42	11.07.2008 15:53:06	43:50:24
		Main	15.07.2008 19:01:54	19.07.2008 02:07:30	79:05:36
		Redundant	28.07.2008 05:02:26	02.08.2008 09:28:03	124:25:37
29	SFB	Redundant	04.09.2008 10:55:31	06.09.2008 06:30:59	43:35:28
30	CNT2	Redundant	11.11.2008 16:32:36	14.11.2008 21:57:56	77:25:20
31	PC9	Main	01.02.2009 05:53:40	01.02.2009 22:49:08	16:55:28
32	THC2	Main	16.02.2009 08:03:49	19.02.2009 14:07:33	78:03:44
33	PC10	Main	23.09.2009 00:02:45	25.09.2009 19:17:57	67:15:12
		Redundant	29.09.2009 10:02:13	04.10.2009 04:17:41	114:15:28
34	SRL	Main	15.10.2009 12:02:45	15.10.2009 16:42:13	4:39:28
		Main	27.10.2009 11:01:57	27.10.2009 19:42:29	8:40:32
		Main	04.11.2009 12:02:45	04.11.2009 16:42:13	4:39:28
35	SRL2	Main	02.02.2010 23:01:58	03.02.2010 03:42:30	4:40:32
		Main	03.02.2010 14:32:06	03.02.2010 23:42:30	9:10:24
		Main	11.02.2010 13:02:30	11.02.2010 19:27:34	6:25:04
36	PST	Main	24.02.2010 11:01:58	24.02.2010 14:38:09	3:36:11
		Main	24.02.2010 15:17:19	24.02.2010 16:52:54	1:35:35

ACCEPTED MANUSCRIPT

#	Activity	Power branch	Activity Start: (UT)	Activity End: (UT)	Duration hh:mm:ss
37	LFR	Main	13.03.2010 00:21:58	15.03.2010 12:57:10	60:35:12
38	PC12	Main	25.04.2010 20:02:46	28.04.2010 00:08:06	52:05:20
		Main	03.05.2010 23:01:58	06.05.2010 01:28:06	50:26:08
		Redundant	10.05.2010 21:02:30	13.05.2010 14:57:42	65:55:12
39	LFB	Redundant	07.07.2010 10:47:02	07.07.2010 13:13:10	2:26:08
		Redundant	10.07.2010 06:47:03	10.07.2010 18:02:15	11:15:12
40	PC13	Redundant	01.12.2010 07:31:00	03.12.2010 19:38:00	60:07:00
		Main	07.12.2010 02:31:00	08.12.2010 19:48:00	41:17:00

Total from Main:	1693:24:31
Total from Redundant:	803:01:09

A total of 40 flight events were performed, starting with a post launch *Non-Explosive Actuator* (NEA) release and continuing through commissioning (CVP) and standard *Payload Checkouts* (PC) through asteroid and planetary fly-bys. The 40 flight events involved a total of 62 ESS main and redundant switch-ONs. Overall, a total of 1693 and 803 operational hours were accumulated between the main and redundant sides, respectively.

At the end of Rosetta's DSH phase (20 January 2014), Philae operations continued with a Post-Hibernation Commissioning (PHC) activity, followed by initial science campaigns and events in preparation for the comet landing. The ESS main and redundant sides were operated for an additional 2133 and 2113 hours, respectively, as listed in the table below.

#	Activity	Power branch	Activity Start: (UT)	Activity End: (UT)	Duration hh:mm:ss
41	PHC-0	Main	28.03.2014 06:02:15	28.03.2014 13:52:39	7:50:24
42	PHC-1	Main	08.04.2014 10:02:15	10.04.2014 17:52:39	55:50:24
43	PHC-CNT	Main	12.04.2014 00:02:47	12.04.2014 01:47:19	1:44:32
44	PHC-2	Main	14.04.2014 05:02:31	17.04.2014 17:52:40	84:50:09
45	PHC-3	Redundant	20.04.2014 21:02:32	23.04.2014 15:53:12	66:50:40
45	PDCS-1	Main	13.07.2014 14:37:30	14.07.2014 20:23:06	29:45:36
46	PST-2	Main	23.07.2014 00:51:54	23.07.2014 06:17:14	5:25:20
47	BattChar-Tx/Rx	Main	04.09.2014 02:02:20	05.09.2014 18:17:16	40:14:56
48	PDCS-Block 4-1	Main	07.09.2014 15:31:56	08.09.2014 06:22:36	14:50:40
49	PDCS-Block 2B	Main	15.09.2014 02:02:20	17.09.2014 01:52:44	47:50:24
50	PDCS-Block 4-2	Main	24.09.2014 20:32:44	25.09.2014 11:22:20	14:49:36
51	PDCS-Block 3	Main	06.10.2014 08:01:49	08.10.2014 00:57:17	40:55:28
52	PDCS-Block 6	Main	16.10.2014 04:01:49	17.10.2014 20:38:05	40:36:16
53	LDP	Main	27.10.2014 02:41:49	28.10.2014 07:47:57	29:06:08
		Redundant	28.10.2014 08:01:49	28.10.2014 20:38:05	12:36:16
54	STCB-Update	Main	08.11.2014 06:02:22	08.11.2014 17:35:42	11:33:20
55	SDL-FSS	Main	10.11.2014 18:07:42	10.11.2014 19:52:14	1:44:32
		Main	10.11.2014 20:33:50	11.11.2014 19:34:06	23:00:16
		Main	11.11.2014 19:39:26	12.11.2014 00:07:10	4:27:44
		Main	12.11.2014 00:12:30	17.11.2014 15:31:58	135:19:28
56	WakeUp-1	Main	12.03.2015 01:02:41	20.03.2015 03:50:09	194:47:28
57	WakeUp-2	Main	12.04.2015 00:01:54	29.04.2015 01:05:54	409:04:00

#	Activity	Power branch	Activity Start: (UT)	Activity End: (UT)	Duration hh:mm:ss
58	WakeUp-3	Redundant	08.05.2015 00:01:55	20.05.2015 00:06:11	288:04:16
59	WakeUp-4	Main	30.05.2015 05:02:43	08.07.2015 08:36:03	939:33:20
		Redundant	08.07.2015 09:02:43	19.09.2015 02:36:38	1745:33:55

Total from Main:	2133:20:01
Total from Redundant:	2113:05:07

This equates to a total operational time of 3826 and 2916 hours for the ESS main and redundant side, respectively. No ESS degradation or failures in terms of ESS HW behaviour or operational functionality were experienced during any of these operations.

Furthermore, during Rosetta's cruise phase, the ESS software was patched in order to incorporate flight experience. The SW patch improved the CDMS – ESS communication link, making the Lander commanding and telemetry transmissions more robust. Moreover, during each Lander telemetry session, the ESS generated two events announcing the start and end of the session. This proved to generate an excessive amount of ESS events that required processing by Rosetta's Data Management System and downlinking to Earth. Due to the reliable communication between the ESS and the CDMS these events became obsolete and were suppressed by the SW patch.

After successful in-flight validation, starting from 2009 the ESS patch was added to the standard ESS power ON procedure and systematically applied at each unit's switch ON.

8 Performance of the ESS

8.1 Performance during the Cruise Phase

As already mentioned above, post launch, the first tasks implemented by the ESS were to support Commissioning of and, thereafter, required on-orbit testing/calibration of the Lander payload instruments. During this phase, commands from the Orbiter to the Lander instruments and platform were passed (see Section 4) through the umbilical cord of the ESS to the CDMS.

The Cruise Phase involved three Earth fly-bys and one Mars fly-by to implement gravity-assist manoeuvres for Rosetta. At flybys of Mars (25 February 2007), asteroid Steins (5 September 2008) and asteroid 21 Lutetia (10 July 2010) a wealth of scientific data recorded by Lander Philae instruments that included the CIVA camera, the magnetometer ROMAP and the PTOLEMY and COSAC spectrometers recorded a wealth of scientific data that were handled by the ESS and subsequently transmitted to Earth by Rosetta.

8.2 Hibernation/wakeup/Philae Landing

To conserve resources, Rosetta was placed in hibernation for 31 months. The signal to Earth was reacquired on 20 January 2014 and no on-board problems were identified. At this time the ESS supported post hibernation commissioning/calibration of the Lander payload instruments. Thereafter, ROSETTA was brought into an orbit about the nucleus in August 2014 at an altitude of ~ 30 km, with relative velocity 1 m/s. A reconnaissance campaign to identify a suitable landing /backup site was then instituted (ultimately chosen to be Site J and Site C respectively). On 12 November 2014 the MSS (supported by the ESS, see Section 3.7) pushed off the Lander from the Rosetta orbiter from an altitude of 22.5 km above the comet's surface'. An adjustable separation velocity (chosen to be 19 cm/s) offered the capability to

define an optimized orbiter trajectory strategy for Lander delivery on 12 November. Provision for the possibility that the push-off signal would not activate was made through providing for the automatic firing, in such a case, of a pyro-device to achieve separation. This variant potentially produced a descent velocity slightly above that estimated for a nominal push-off while also affecting the descent trajectory and it was decided to use the same ejection velocity in both cases. In the event, the signal operated nominally.

Philae started its ~7-hour descent to the surface of the comet at 08:35 UT on 12 November. Its destination, resulting from the reconnaissance campaign, was landing site J/Agilkia on the ‘head’ of the cometary nucleus. During descent, a pre-programmed command sequence already stored in Philae before separation was executed automatically by the CDMS which allowed: CIVA to take farewell images of Rosetta; CONCERT to investigate gravity, surface and subsurface properties; ROLIS to take descent images; ROMAP to make magnetic measurements and SESAME to make dust and plasma measurements.

8.3 *First Science Sequence (FSS) on the nucleus*

Philae touched down at 15:34 UT on 12 November only 150 m away from its nominal target. Since the harpoons, which were to anchor the Lander to the comet's surface failed to fire, while also an active descent cold gas system did not operate and ice screws in the legs did not maintain purchase, Philae was reflected on impact and set off on a tumbling/ bouncing excursion of more than 1 km across the cometary-landscape. It came to rest almost two hours and two further brief surface impacts later in a heavily shadowed area. During this excursion, preloaded commands intended to implement surface science at Agilkia were delivered by the CDMS to the Lander instruments on schedule.

In particular twenty-five minutes after touchdown while Philae was still in flight above the cometary surface, the COSAC mass spectrometer took, according to the pre-programming, a spectrum of dust thrown up by the impact (Goesmann et al., 2015). A complementary spectrum was obtained by Ptolemy (Wright et al., 2015). These important measurements were retrieved by the ESS and later transmitted to Earth by Rosetta.

8.4 *The Final Landing Site*

The limited battery power remaining when Philae came to rest (at a site named Abydos) meant that further scientific measurements of the Lander had to be implemented within around two days without any accurate knowledge of the characteristics of this landing site or of the attitude of the Lander. In these circumstances, the Lander Team re-programmed the *First Science Sequence* (FSS) commands which, after handling by the ESS were successful in operating each of the Lander instruments at least once (some even several times) before the primary battery failed. The data thus measured were retrieved by the ESS and measurements continued until shortly after midnight on 15 November 2014 when the electrical power was running seriously low. In these circumstances the computer aboard Philae switched the Lander into ‘hibernation mode’ and, thereafter, no further data were transmitted to the ESS.

A special issue of *Science* (Vol. 349, 2015) contains nine papers concerning Lander on-comet measurements and a plethora of others appear, inter alia, in *Nature*, *Planetary and Space Science* and *Astronomy and Astrophysics*. See also a virtual special issue of *Planetary and Space Science* which combines thirty two papers published across four Elsevier planetary science journals. These publications attest to the fulfilment of the brief of the ESS, in its capacity of mission critical hardware, to correctly handle the transfer of scientific measurements from Philae to Rosetta.

8.5 *Requirements for Philae wakeup*

Before hibernation, since the nominal operations mode foreseen to be used at Agilkia was to turn on its receivers periodically and this potentially might result, when the Lander had reawakened, in missing brief contacts, the Operations Team reconfigured the on-board software to switch on both (redundant) transmitters whenever the rechargeable secondary battery reached a minimum 3.4V cell voltage, or if sufficient surplus solar power was available.

There were two requirements for Philae to ‘wakeup’ at Abydos: (a) its internal temperature should be above -45°C and (b) it should be receiving $> 5.5\text{ W}$ of power. Two rectangular solar absorbers located on top of the Lander can transform sunlight into the heat required to warm up the Lander’s interior from an estimated -110°C (or less) on the comet to -45°C . At the latter temperature a mechanical switch is designed to operate to allow the CDMS to start powering up, assuming that at least the 5.5W of power mentioned above are available. The temperature increase required had to be achieved very rapidly at Abydos in late 2014 since only 1.3 hours of sunlight were then available at this site per comet day. Moreover, the temperature of the battery had to reach 0°C before it could start recharging. Once the CDMS has booted up and the power it receives totals 9W , Philae is pre-configured to switch on its receiver every half an hour and listen for five minutes for a signal from the ESS (see below). For the Lander Team to know that Philae is awake it must turn on its transmitter and this requires the availability of an additional 10W of power. Overall, 19W are required for a successful wakeup.

To establish successful communications with Philae, the ESS must be switched on and configured in ‘Research Mode’ (such that its transmitter is switched on and sending signals with a particular pattern that is recognized by Philae). In parallel the ESS receiver is switched on in order to detect any possible response. When either of the receivers on Philae identifies a signal from the ESS, the onboard software in the CDMS performs a check to determine if there is enough power available to switch on one of its two redundant transmitters. If yes, one transmitter is turned on and returns a signal with a specific pattern, thereby signalling the ESS that conditions are suitable to establish a two-way link. Philae can then proceed to uplink science and housekeeping data that are stored in its Mass Memory. Also, in this configuration, the ESS can send new command sequences for loading and execution.

On 13 June the Lander sent a signal (duration 78s) to the ESS showing that its temperature and power were both in a state sufficient to support Lander operations and there was even an indication that the Lander had already been awake earlier (in April/May) - but not in circumstances when a signal could be successfully transmitted to the ESS. During the June contact, some 343 packets of housekeeping telemetry ($\sim 100\text{ Kbytes}$) were received by the ESS (i.e. information from the thermal, power and onboard computer subsystems). Six further contacts were later made and some further data transmitted but these links were weak and intermittent.

An attempt was, thereafter, made to use the TC Backup Mode/TCBM (see Section 6) to turn on the CONSERT instrument aboard Philae. This involved loading a small number of commands into the ESS and transmitting them repeatedly in a pattern recognizable by Philae. On 9 July a full two-way link was established with the Lander for 22 minutes and a total of 246 packets of housekeeping data were retrieved by the ESS for that comet day, both real time

and stored in the Mass Memory. Meanwhile, although CONSERT was switched on it did not transmit any data.

Analysis indicates that, for a further successful contact, it is required that one of the two transmitters on-board Philae (both of which are presently unreliable) will operate correctly while also a suitable alignment between the Lander and Orbiter antennae should pertain (the antenna aboard the Lander is currently pointing below the local horizon and a work-around solution is sought). A new listening campaign is planned starting in mid-October 2015 and continuing through to December 2015, perhaps also extending into early January 2016, while the distance between the ESS and the lander remains less than the ~200 km required to support two way communications. Thereafter, no further contact from Philae can be anticipated.

9 Conclusion

The ESS decodes, verifies and executes telecommands (TCs) addressed by the Orbiter to the ESS itself, the ESS-Tx/Rx system, the MSS and to Philae while it is still attached to the Orbiter. Commands addressed to the Lander platform/units are wrapped in a transfer frame and forwarded (via the umbilical or RF link) to the CDMS which manages the payload instruments.

Data originating at the individual Lander experiments measured while en-route to and at the comet are also handled by the ESS which receives and reformats them prior to their transmission by Rosetta to Earth.

Post launch, the first tasks implemented by the ESS were to support Lander commissioning and required on-orbit testing/calibration of the Lander payload instruments. The ESS operated nominally during the 'busy' Cruise Phase of Rosetta (with flybys of Mars and of asteroids Steins and Lutetia) when, in particular, it successfully handled the retrieval from Philae at each object of unique scientific data.

After the emergence of the spacecraft from a seven month hibernation (20 January 2015) the ESS supported renewed testing/calibration of the Lander payload instruments. On 12 November 2015, in combination with the MSS, it participated in the deployment of Philae to the nucleus of comet 67P/Churyumov-Gerasimenko. Thereafter it successfully handled the retrieval of measurements made by instruments of the Lander payload while traversing the comet landscape at a height of about 150km after the first 'bounce' and at the landing site Abydos. Since the success of the Lander Mission depended on the successful acquisition of scientific data, the performance of the, mission critical, ESS in handling the scientific measurements allowed Philae to be defined as a major scientific success.

In the circumstance that the sum total of operational hours from launch up to the end of the mission should not exceed the guaranteed operational lifetime of the ESS, activity sharing was required during the mission between the main and redundant sides of this system. A total operational time of 3826 and 2916 hours for the ESS main and redundant side, respectively, was implemented thus far and operations are still ongoing. No ESS degradation or failures in terms of ESS HW behaviour or operational functionality were experienced during any of these operations and the redundant side was never invoked for problem solving.

The ESS also participated in several campaigns to contact the Lander at site Abydos following the emergence of Philae from approximately seven months of hibernation on the comet nucleus (13 June 2015). Some additional measurements were retrieved from Philae during certain of the brief, and intermittent, contacts achieved. At the time of writing, the ESS is on standby to participate in a new campaign to contact the Lander and obtain additional data from it. This effort extends from mid-October 2015 into January 2016. When, as Rosetta continues along its planned trajectory away from the comet, the separation distance between

the Orbiter and Philae exceeds the ~ 200 km required for the successful transmission of signals between these bodies, no further communications with the Lander can take place.

Appendix A

ESA's System Specifications for the ESS

A1. ESA's Initial System Specification

The initial ESS system specification was contained in ESA document R0-LAN-SP-3101 which established the requirements that this system had to meet.

First, it was to be located aboard the ROSETTA spacecraft/Orbiter where it would serve as the data, telecommunications and power interface between the Orbiter, the Lander and the Mechanical Support System (MSS) – which was itself mounted on the Orbiter. When the Lander was still attached to the spacecraft during the Cruise Phase, communications would be accomplished via the umbilical. After separation a radio link would be required. A telecommunications system (Tx/Rx) would guarantee communications between the Lander and the ROSETTA orbiter via the ESS.

A2. Units of the ESS

The major units of the ESS were specified to consist of:

- Power units connected to two Orbiter 28V Latching Current Limiter (LCL) lines switched on by the On Board Data Handling (OBDH) system.
- Two fully redundant CPU cards, each connected to one of the redundant Tx/Rx units.
- An umbilical interface between the ESS Processor Unit and the Lander Command and Data Management System (CDMS) providing data communication and power lines to the Lander while the Lander was still physically attached to the spacecraft.
- An electrical interface between the ESS Processor Unit and the MSS, providing the required power and data interface for operating and monitoring the MSS.
- An electrical interface between the ESS Processor Unit and the Orbiter OBDH through the Remote Terminal Unit (RTU).

It is noted that the telecommunication system aboard the Lander consisted of two redundant Tx/Rx units connected via two couplers to a Tx and an Rx antenna pointing in the +z direction of the Philae reference frame. The Tx/Rx units and antenna on the spacecraft and on Philae are identical copies of one another.

A3. The ESS Processor Unit

The ESS Processor Unit (PU) was required to exchange information with:

- The Orbiter RTU (which formed the interface with the OBDH)
- The Lander CDMS before Lander release (via the umbilical)
- The ESS telecom equipment (transmitter, receiver, co-axial relays)
- The MSS

and to fulfil the following functional requirements:

- The ESS should be realized in full redundant design to ensure access to the ROSETA Lander during both Cruise and Comet Operations in case one ESS unit would fail. If an error state in the ESS should occur (either reported to or detected by the OBDH), the OBDH would react by switching the power to the redundant power line for the supply of the alternative branch of the ESS.
- It should receive, acknowledge and process TC packages addressed from the Orbiter OBDH to the ESS.
- It should receive, acknowledge and buffer TC packages addressed from the Orbiter OBDH to the ESS. These buffered packages were to be transmitted to the Lander when a telecommunications link became available or, prior to Lander release, via the umbilical.
- The ESS should receive TM packets from the Lander as well as time-stamp and buffer the packets for immediate, or later, transmission of the TM packages to the Orbiter OBDH.
- It should acquire and transmit ESS housekeeping TM packets to the Orbiter OBDH.
- Also, it should ensure correct transmission of TC and TM packages packets
- Monitor the status and activity of the MSS and
- Initiate the ejection process of the Lander through:
 - Supporting time synchronization of the CDMS with the Orbiter clock.
 - Initiating MSS activity.
 - Initiating the CDMS ejection sequence.
 - Activating the RF link 10s after ejection has been detected.

A4. Data Interfaces

Data communications between the ESS with the Orbiter and with the Lander were required to comply with ESA's telecommand/telemetry packet standards. The following functions were, in particular, to be supported by the ESS.

For telecommand functions and on-board time:

- Each of the two redundant ESS processor cards should support TC packet reception from the RTU realized by a synchronous 16-Bit serial interface. Physically the command interface should comprise a three line serial interface (Data, Clock and Sampling Line), operated at an appropriate rate for the transmission of telecommands.
- The ESS should provide sufficient kbytes of volatile mass memory for the buffering of TC data. Packets should be stored until they were received and acknowledged by the Lander CDMS.
- The ESS should provide a data interface for TC transmission with the Lander via the umbilical or RF link, at a bit rate of about 16 kbits.
- The ESS should accept a broad pulse providing on-board time for ESS and Lander timing and synchronization.
- The ESS should provide a data interface for commanding and monitoring the MSS.

A5. Telemetry Interfaces

- Each of the two redundant ESS processor cards should provide for the transmission of TM packets to the OBDH using a synchronous 16-bit serial interface. Physically the command

interface was to be realized using a three line serial interface (Data, Clock and Sampling Line) operated at an appropriate rate for the transmission of TM packages.

- The ESS should provide sufficient Mbytes of volatile mass memory for the buffering of Lander TM data. The Orbiter Central Data Management Unit (CDMU) would sequentially acquire data packets from the Lander experiments and the dumping of this memory should take less than one hour.
- The ESS should provide a data interface to support TM transmission with the Lander via the umbilical or an RF link at a bit rate of about 16 kbits.
- The ESS should acquire and packetize ESS transmitter, receiver and MSS housekeeping telemetry.

A6. The Electrical Interface

The ESS power unit should accept the input of two, alternative, independent LCL 28V power lines switched by the ROSETTA OBDH. The power of each of these lines was to be conditioned independently for: one of the redundant CPU cards, for the Tx/Rx units and for the MSS.

The power (dependent on mode (primary consumption) was to be as follows:

- | | |
|--|--------|
| • ESS Processor ON | 4W |
| • ESS Processor and receiver ON | 5.5 W |
| • ESS Processor, receiver and transmitter ON | 12.5 W |

Further,

- The ESS should be operational with voltage power in the range $28V \pm 3V$. Short circuits of $100\mu s$ on the external power lines should be survivable.
- The ESS power line should provide voltages of +5V for operation of the Tx/Rx units, +12 V for RF switches and + 12 V for the MSS.
- The ESS should provide an umbilical interface to the Lander containing power and data lines. The power lines should include uncontrolled power provision for 2x8 redundant resistance heaters used for the thermal control of the Lander during the Cruise Phase.

An additional interface between the Orbiter and the Lander should be formed during the Cruise Phase using 10 thermistors provided by the RTU, but connected directly to the Orbiter without any ESS involvement.

A7. The Thermal and Mechanical Interface

The ESS Processor unit would be placed under the thermal control of the Orbiter.

The ESS Processor unit should be mounted within the Orbiter with a mechanical envelope of $170 \times 150 \times 80 \text{ mm}^3$. The mass should not exceed 1.8 kg.

A8. Operational Requirements

The RF system should only be activated when RF communications with the Lander were foreseen. Otherwise only the ESS should be active. A maximum distance between the Lander and the Orbiter of $\sim 150 \text{ km}$ should be taken into consideration. It is noted that, at the comet, satisfactory communications could be achieved at $\sim 200 \text{ km}$.

A9. Telecommunication formats

- The data rate for telecommand transmission (ESS -> Lander) was required to be 16,000 bits/s
- The data rate for Telemetry transmission (Lander-> ESS) was required to be 16,384 bits/s.
- A handshake request to send protocol (full duplex) should be used to allow safe RF communications between the ESS and the Lander. In any case, a specific signal would precede the TM and TC sessions in order to wake up the receiver
- The Telemetry and Telecommand links were required to be subject to a Cycle Redundancy Check (CRC), then convolutional 7₂ encoded.
- The overall mass of the ESS (including Tx/Rx, support structures, harness etc.) with the Orbiter and Lander was required overall not to exceed 4.2 kg.

References

- Bibring, J.-P., H. Rosenbauer, H. Boehnhardt, S. Ulamec, J. Biele, S. Espinasse, B. Feuerbacher, P. Gaudon, P. Hemmerich, P. Kletzkine, D. Moura, R. Mugnuolo, G. Nietner, B. P. Atz, R. Roll, H. Scheuerle, K. Szego, K. Wittmann, Philae Project Office and the entire Philae Team, The Rosetta Lander (“Philae”) investigations, *Space Sci. Revs.*, (2007), **128**, pp. 205–220.
- Glassmeier, K.-H., H. Boehnhardt, D. Koschny, E. Kuhr and I. Richter, The Rosetta Mission: flying towards the origin of the Solar System, *Space Sci. Revs.* (2007) 128, pp. 1-21.
- Goesmann, F., H. Rosenbauer, J. H. Bredehöft, M. Cabane, P. Ehrenfreund, T. Gautier, C. Giri, H. Krüger, L. Le Roy, A. J. MacDermott, S. McKenna-Lawlor, U. J. Meierhenrich, G. M. Muñoz Caro, F. Raulin, R. Roll, A. Steele, H. Steininger, R. Sternberg, C. Szopa, W. Thiemann and S. Ulamec, Organic compounds on comet 67P/Churyumov-Gerasimenko revealed by COSAC mass spectrometry, *Science* (2015), Vol. 349 no. 6247, DOI:10.1126/science.aab068.
- Wright, I. P., S. Sheridan, S. J. Barber, G. H. Morgan, D. J. Andrews and A. D. Morse, CHO-bearing organic compounds at the surface of 67P/Churyumov-Gerasimenko revealed by Ptolemy, *Science*, (2015) Vol. 349, no. 6247 DOI: 10.1126/science.aab0673.

Selected Technical Documentation

- Science Rosetta Lander ECDR- data package Part 2 (System) ROL-DLR-/SU-TN-002-97/2, (May 1997).
- Rosetta Lander Subsystem Review, RO-LAN-MN-3101-gs (21-23 October, 1997)
- Rosetta Lander, System Specification, RO-LAN-SP-3101 (June 1998)
- Rosetta Lander USER Manual, RO-DLR-UM-3100, (August 2003)
- Post launch, Successive minutes of the Rosetta Lander Progress Meetings
- Post launch, Successive minutes of the Steering Board of the Rosetta Lander

Figures

Figure 1. Top-level block diagram of the ESS Processor.

Figure 2. The Lander MSS and ESS redundancy concept.

Figure 3. Detailed functional block diagram of the ESS Processor (nominal unit).

Figure 4. Memory Load Interface (left) and TM Data Acquisition interface (right) block diagrams.

Figure 5. Time Synchronisation Interface.

Figure 6. Tx/Rx Serial Interface.

Figure 7. Tx/Rx Housekeeping Interface.

Figure 8. ESS-MSS interface.

Figure 9. Umbilical drivers.

Figure 10. Overview of the ESS-Lander Power Distribution Scheme.

Figure 11. Schematics of the ESS software tasking.

Figure 12. ESS software functional overview - the communication between tasks.

Figure 13. The full set of ESS pc-boards during the population process. Top three boards (from left: PD, IF, CPU) create the nominal unit. The bottom three identical boards create the redundant unit.

Figure 14. ESS Processor integration in STIL's Class-100 Clean Room.

Figure 15. The completed ESS Processor during a vibration test.

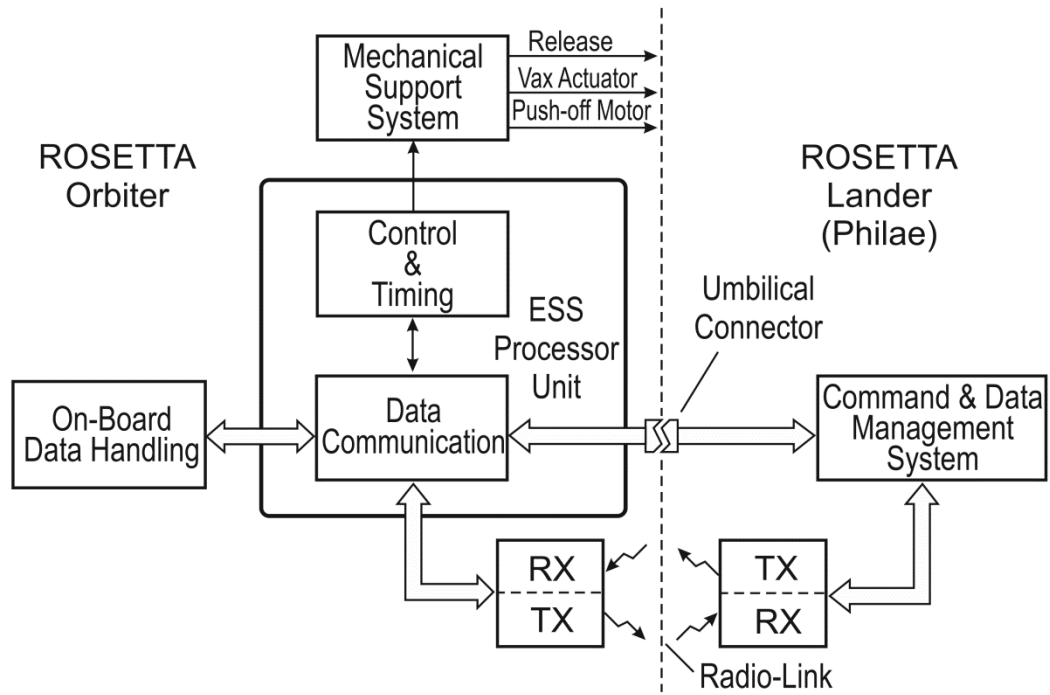

Figure 1. Top-level block diagram of the ESS Processor unit.

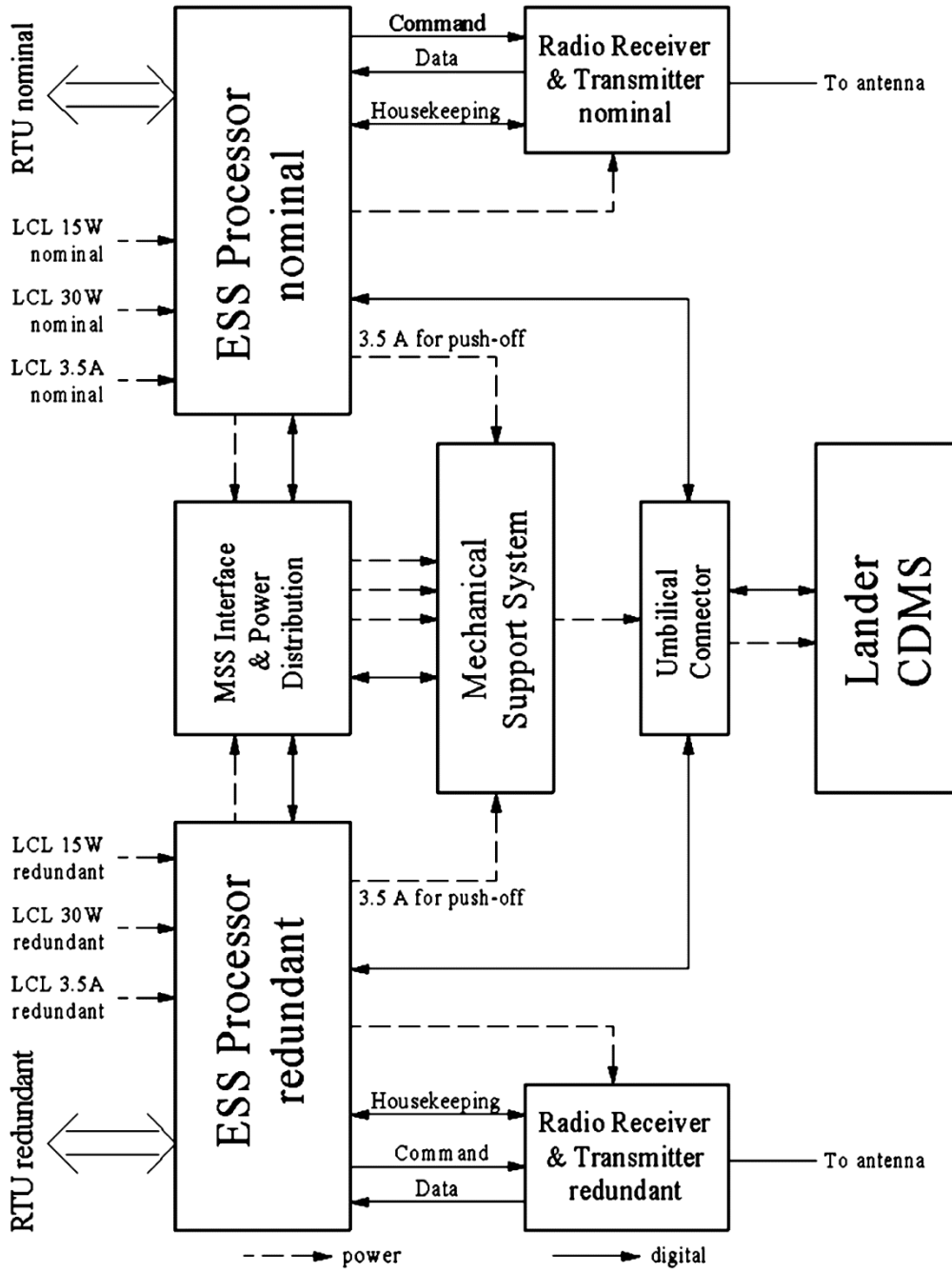

Figure 2. The Lander ESS and MSS redundancy concept.

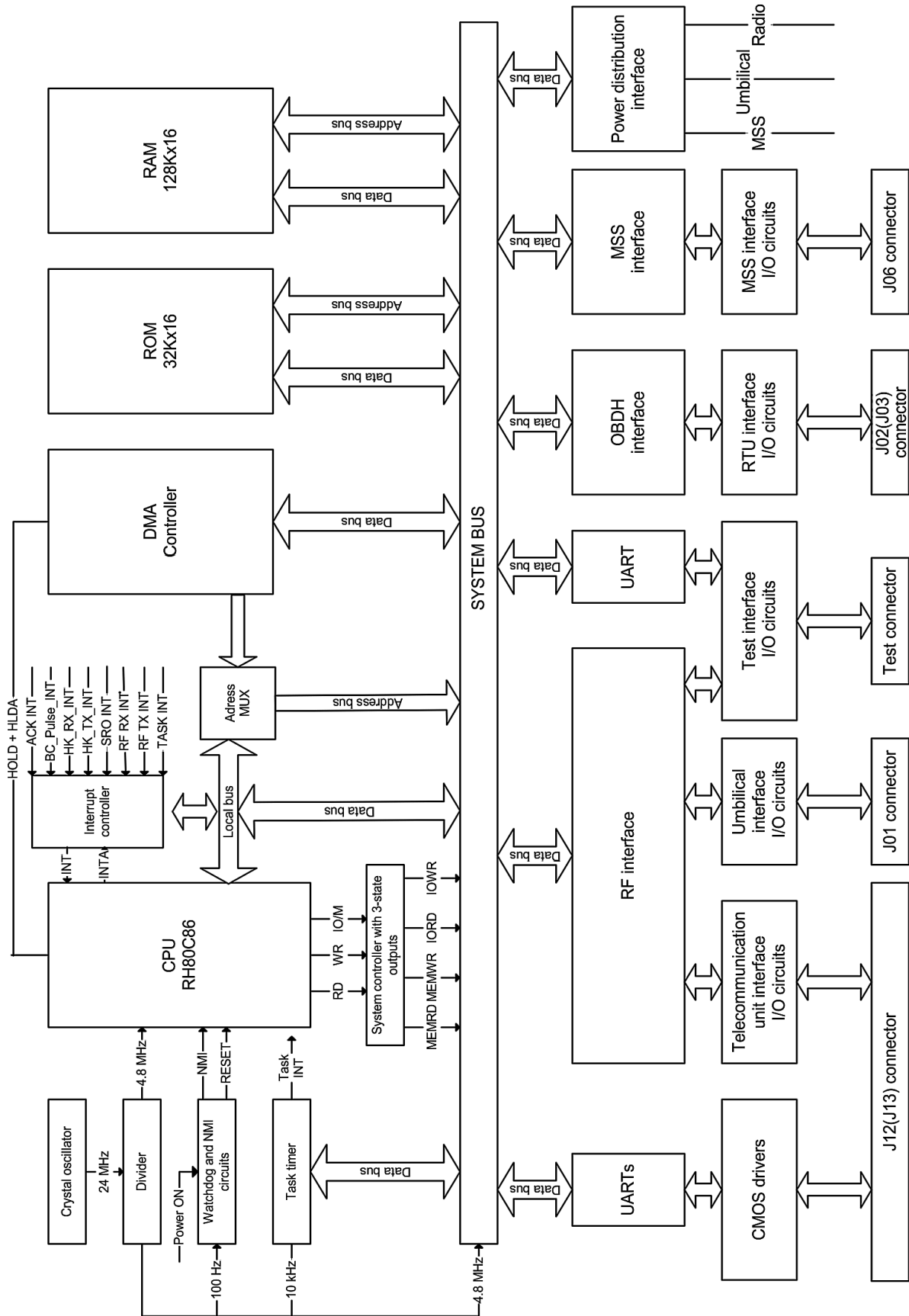

Figure 3. Detailed functional block diagram of the ESS Processor (nominal unit).

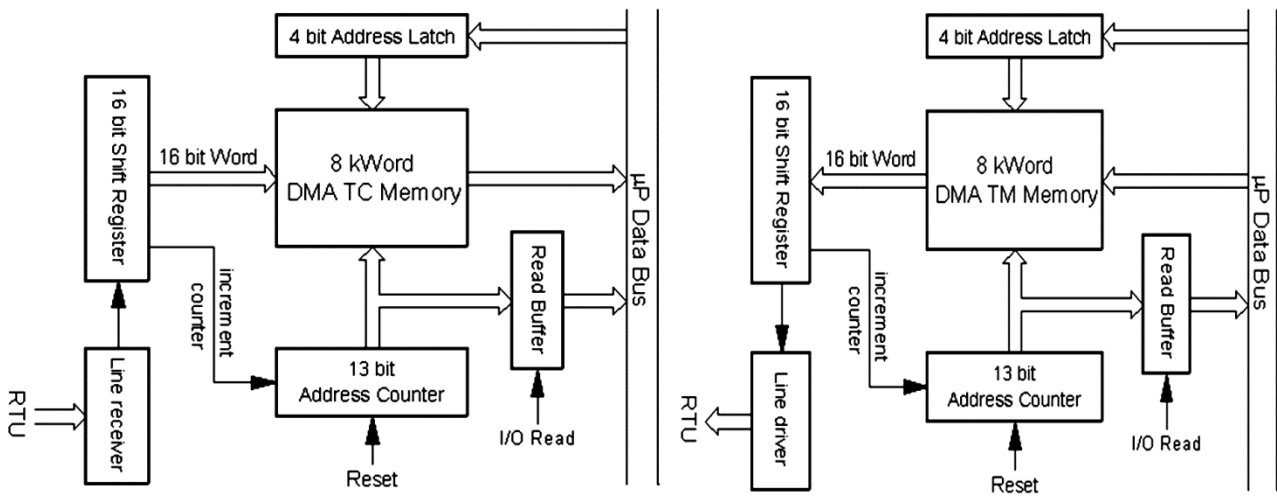

Figure 4. Block diagrams of the Memory Load Interface (left) and TM Data Acquisition interface (right).

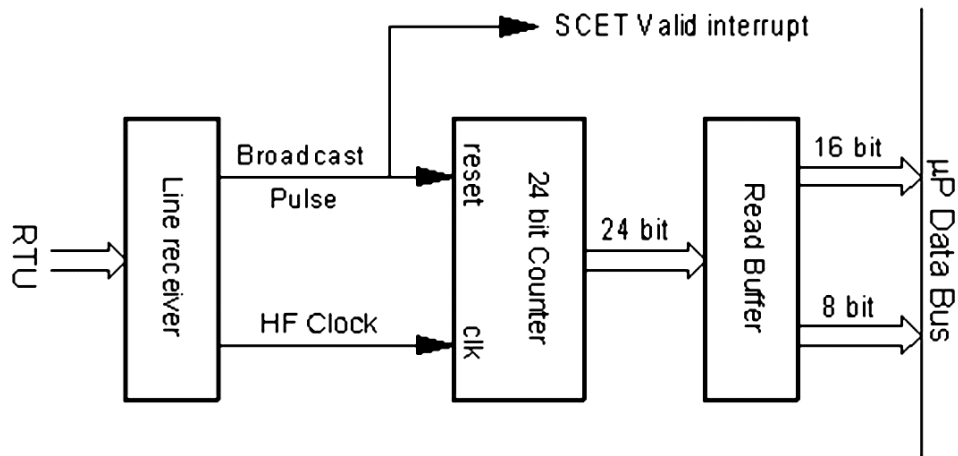

Figure 5. Time Synchronisation Interface.

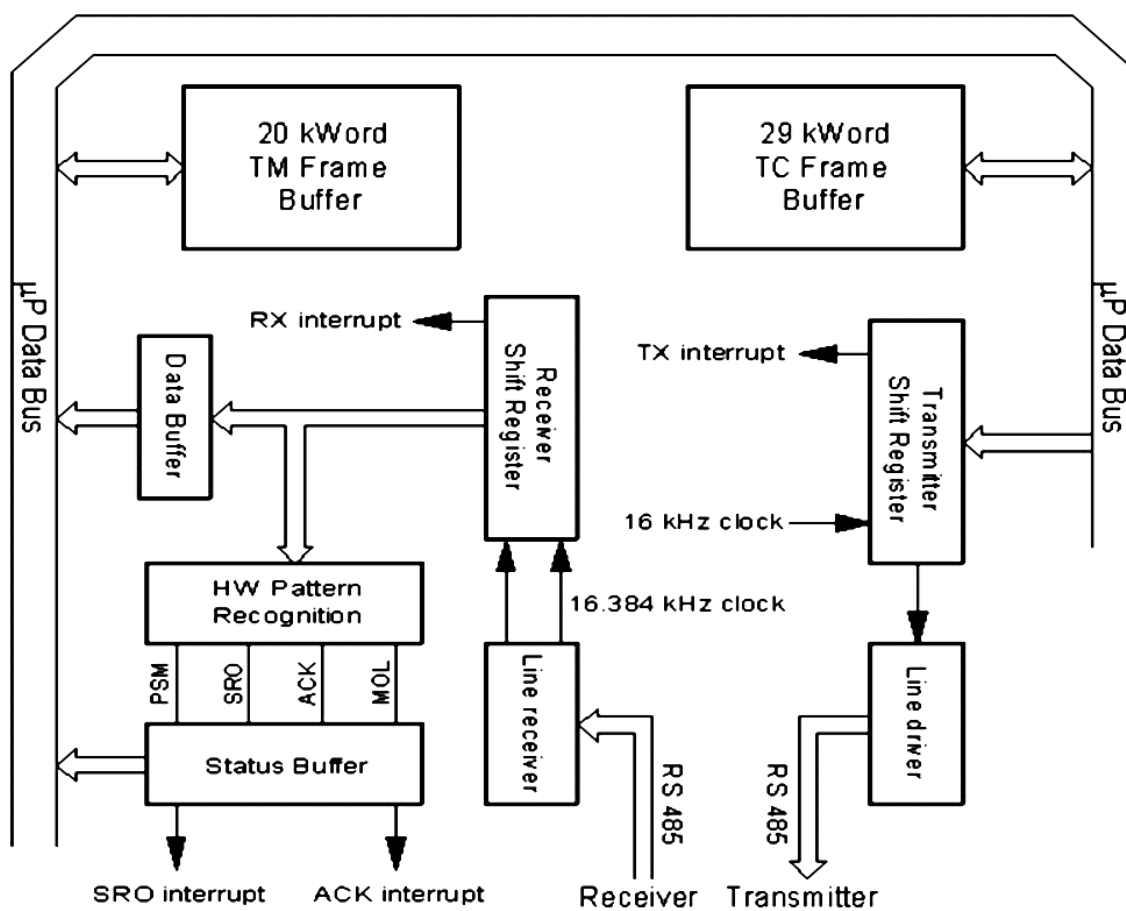

Figure 6. Tx/Rx Serial Interface.

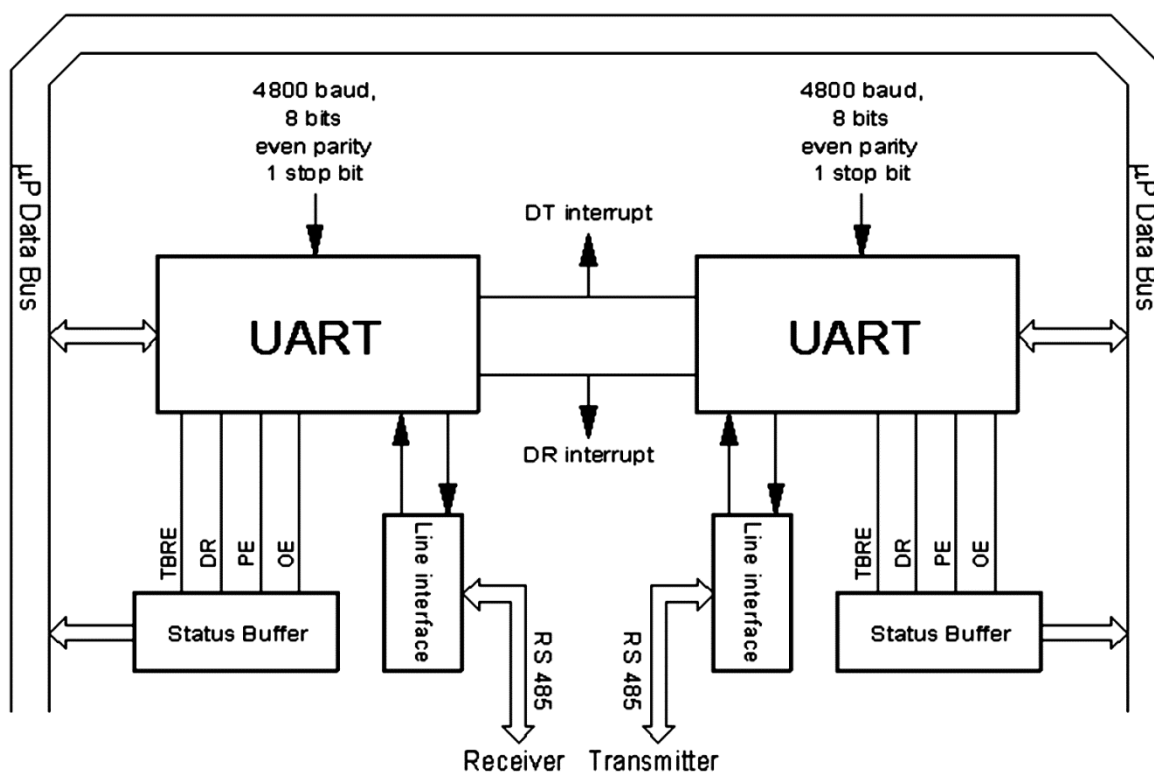

Figure 7. Tx/Rx Housekeeping Interface.

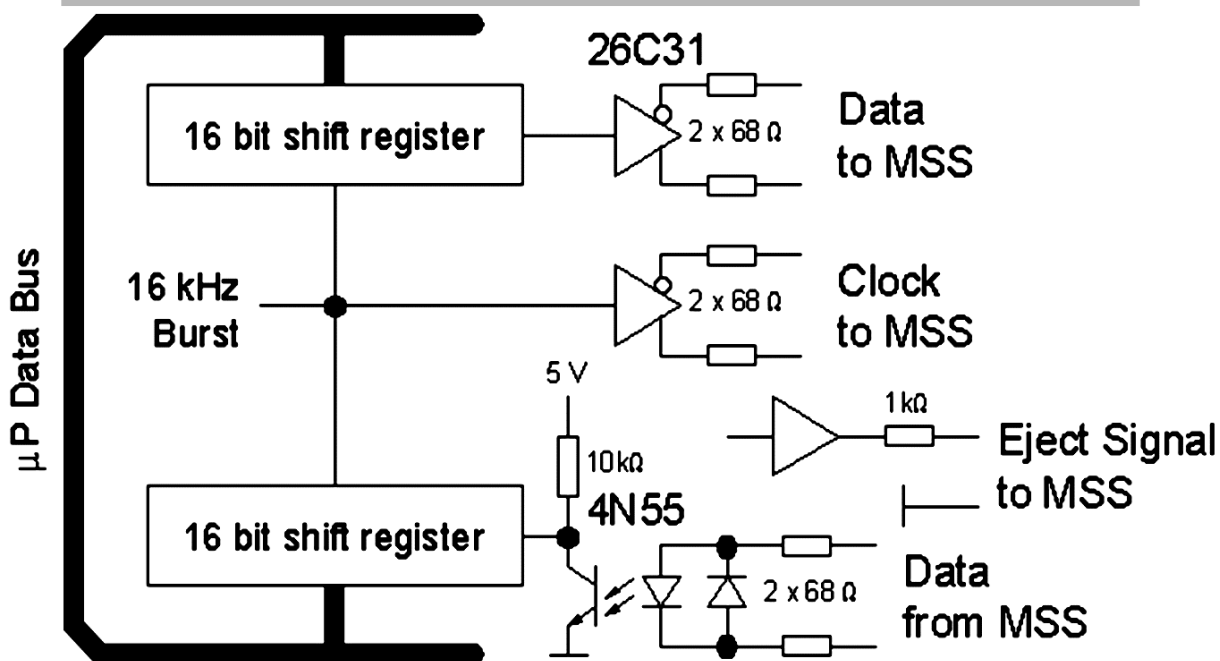

Figure 8. ESS-MSS interface.

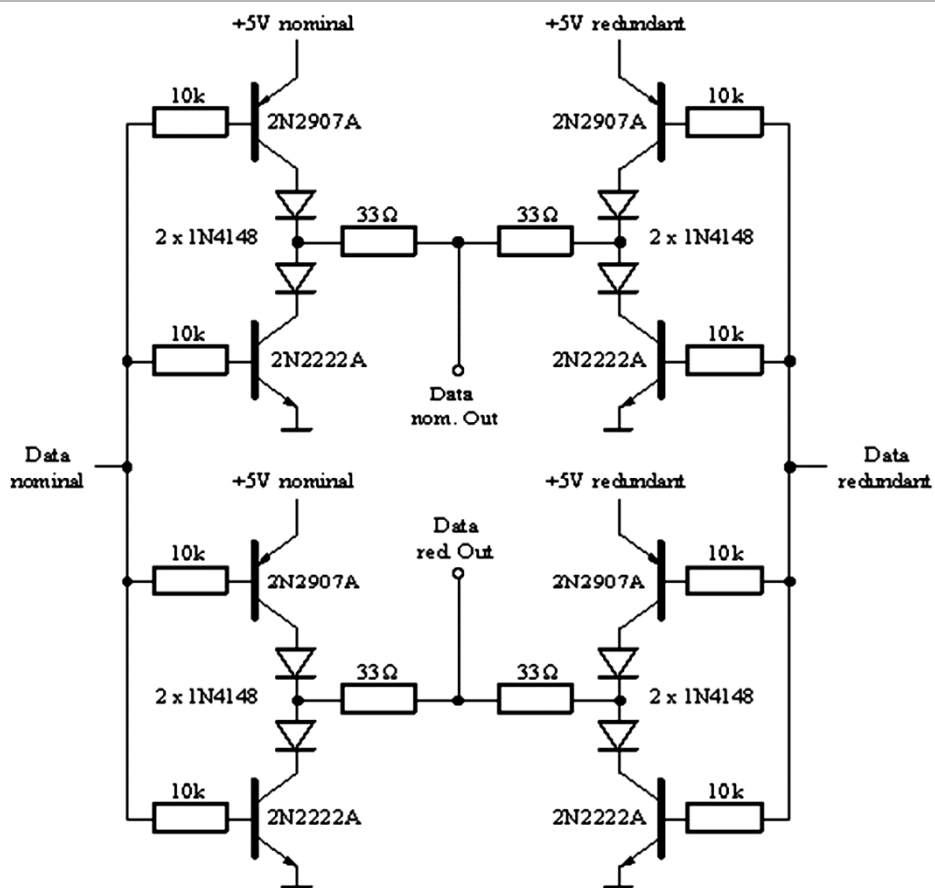

Figure 9. Umbilical drivers.

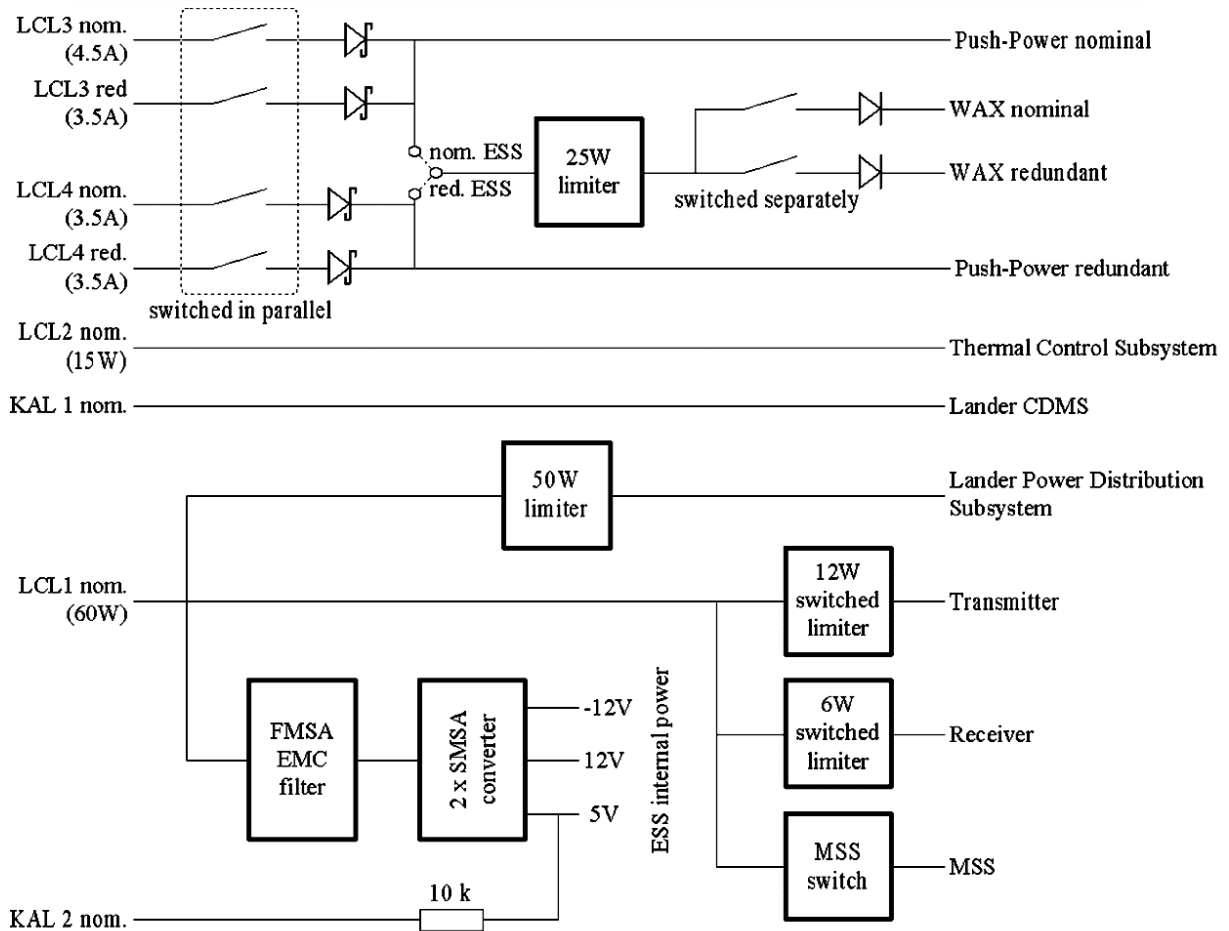

Figure 10. Overview of the ESS-Lander Power Distribution Scheme.

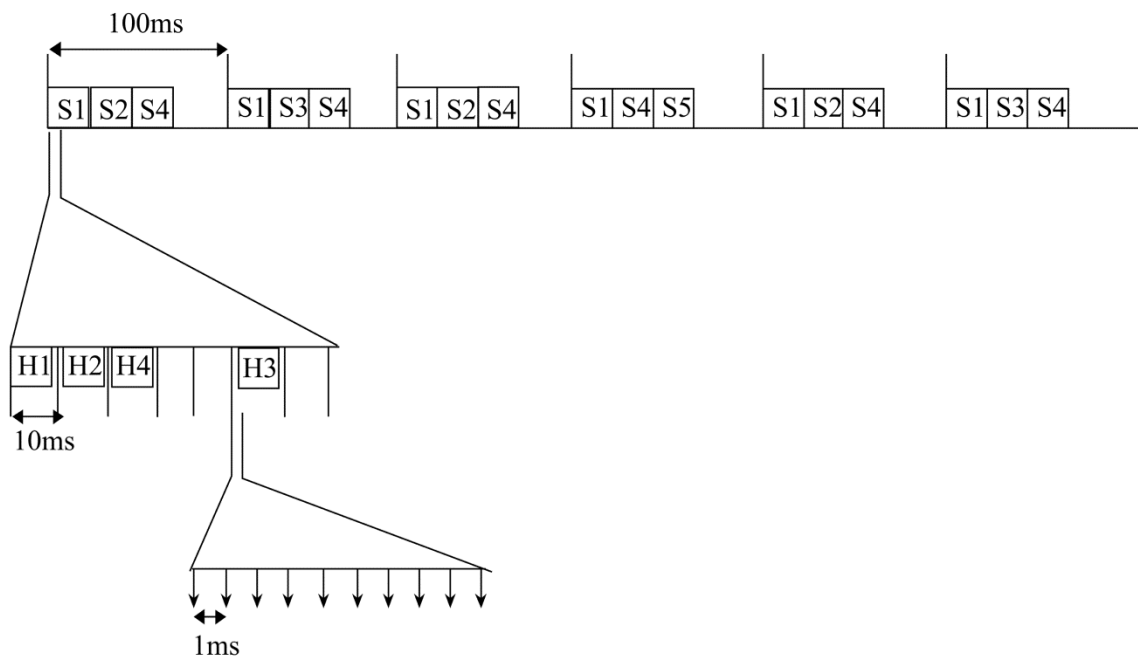

Figure 11. Schematics of the ESS software tasking

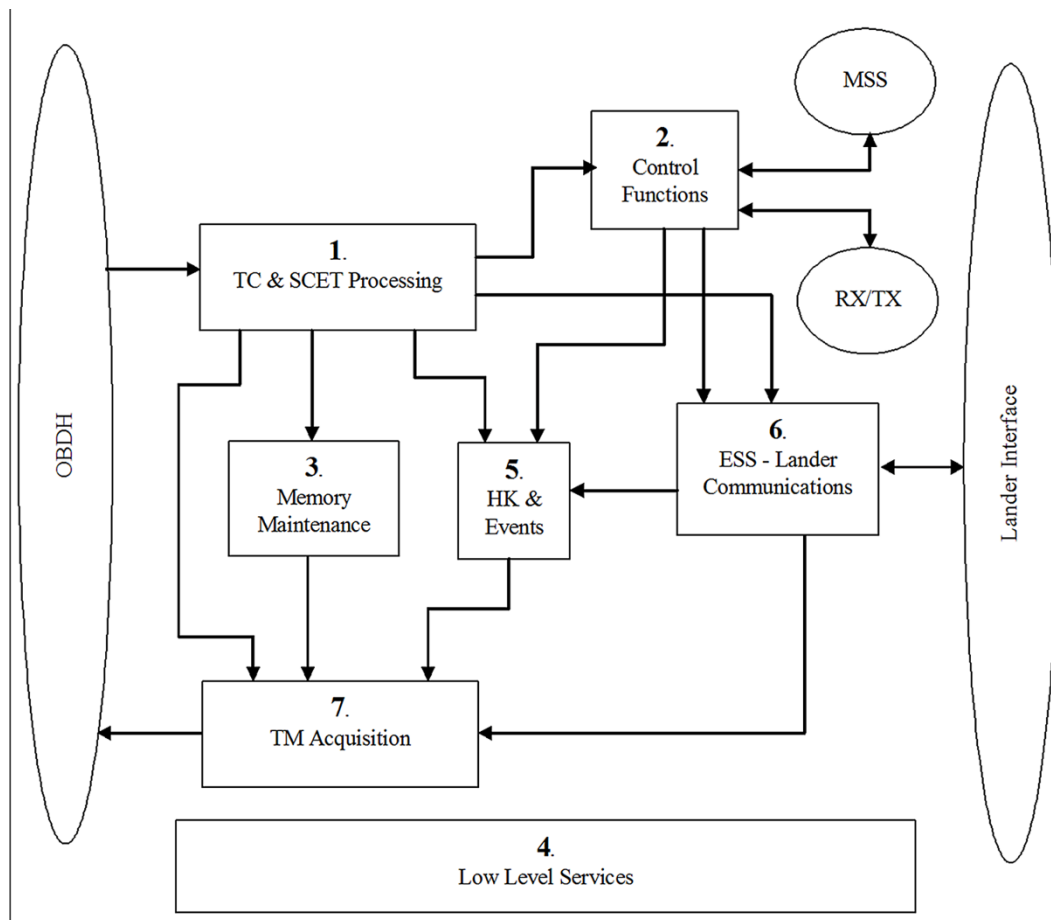

Figure 12. ESS software functional overview - the communication between tasks.

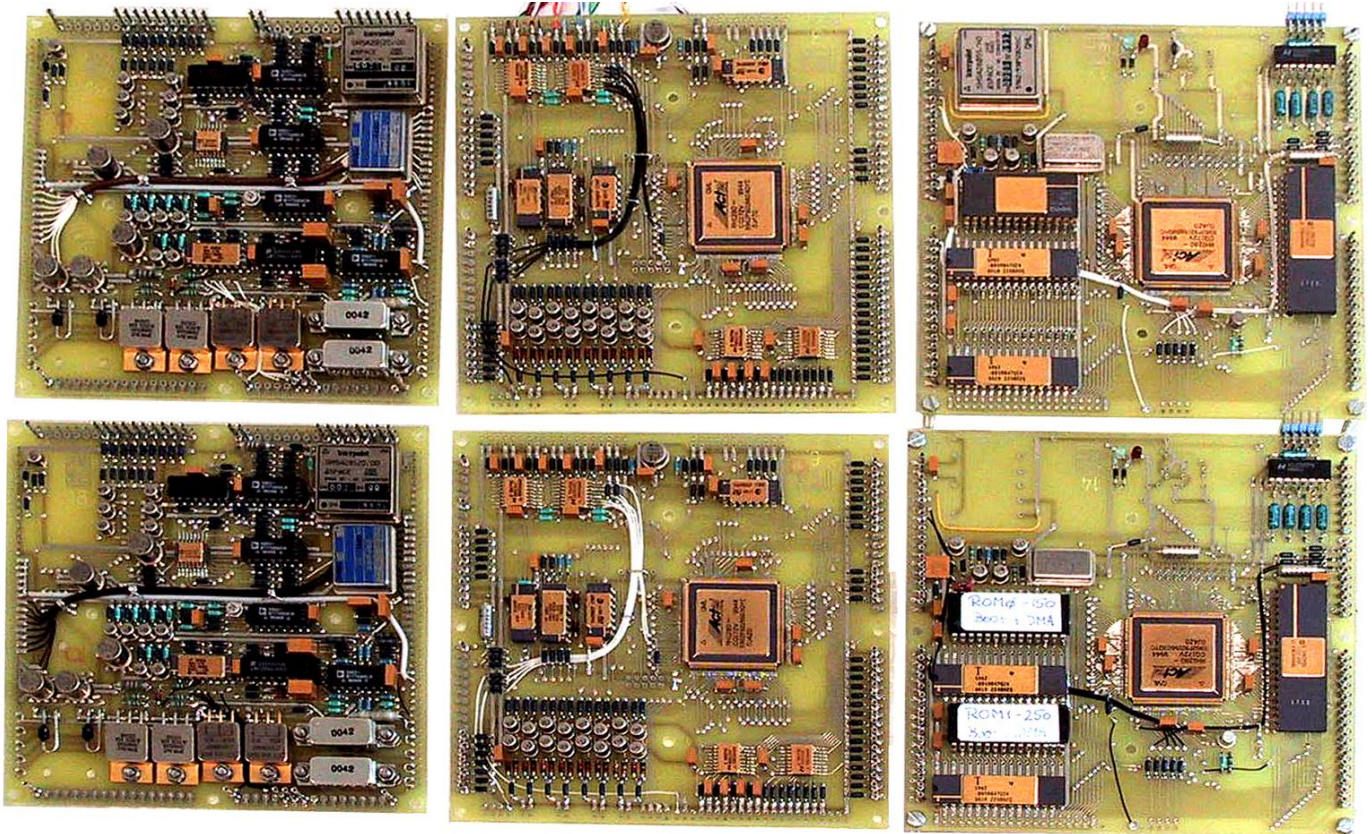

Figure 13. The full set of the ESS pc-boards during the population process. Top three boards (from left: PD, IF, CPU) create the nominal unit. The bottom three boards create the redundant unit.

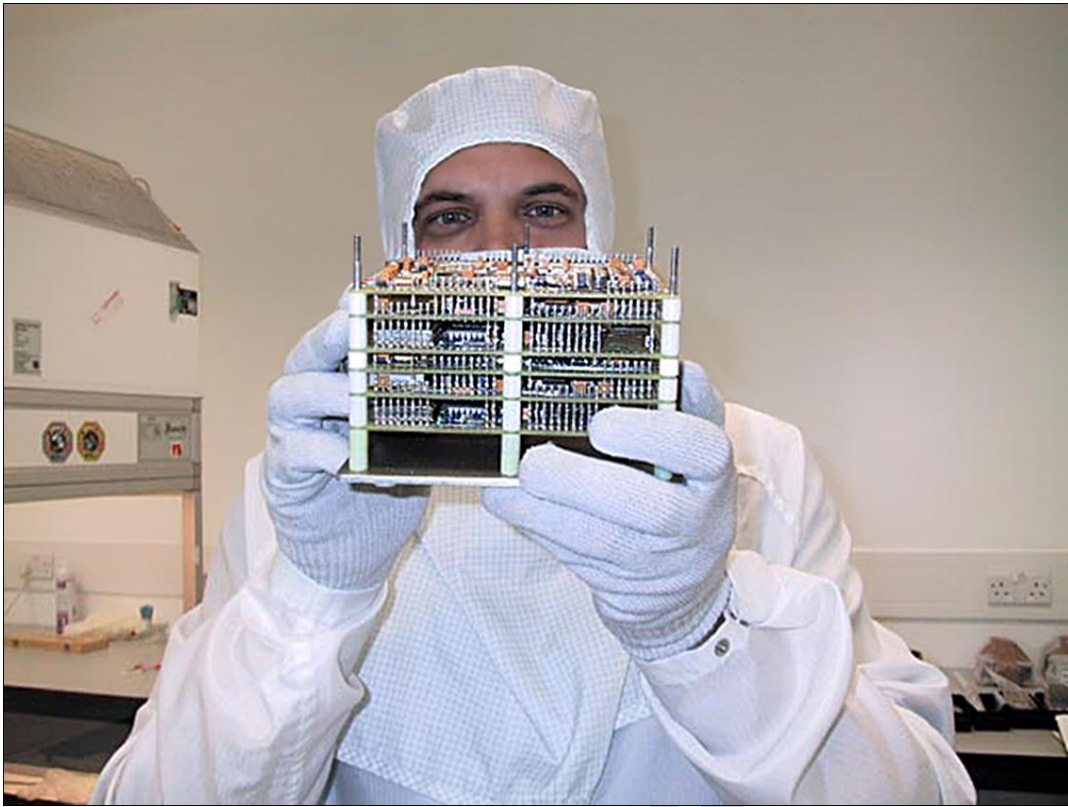

Figure 14. ESS Processor integration in STIL's Class-100 Clean Room.

Accepted manuscript

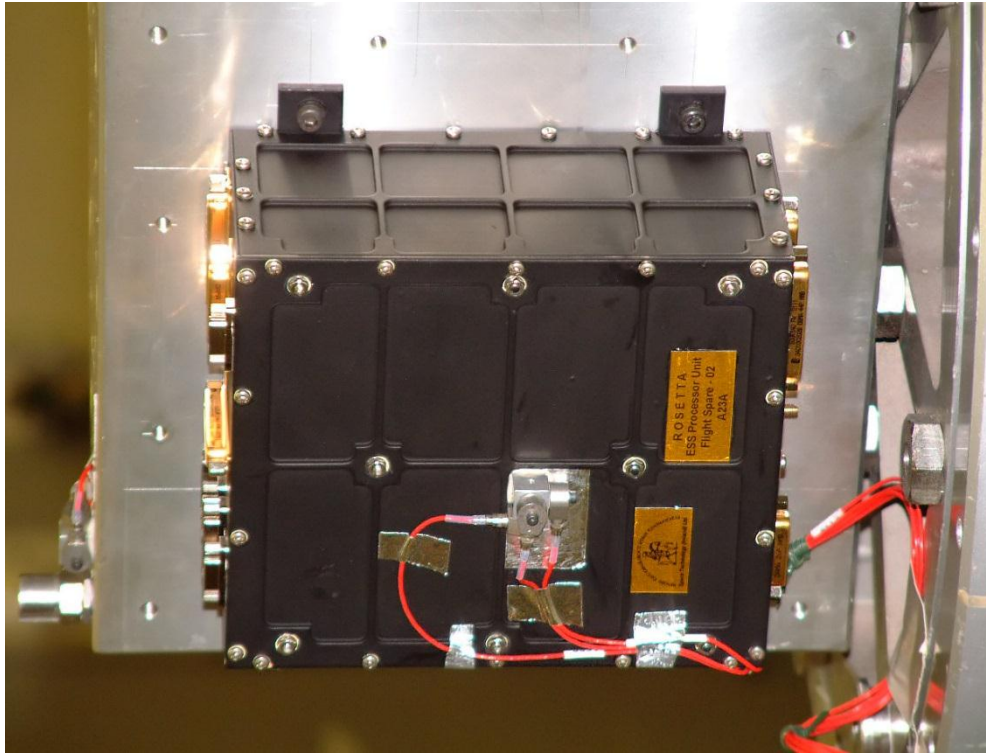

Figure 15. The completed ESS Processor during a vibration test.

Highlights

- The ESS Processor is a highly reliable system mounted aboard the Rosetta spacecraft
- ESS wraps commands from Rosetta in a transfer frame for forwarding to Lander Philae
- Data measured by the Lander experiments are received and formatted by the ESS
- The ESS performance throughout the cruise phase and at the comet was always nominal