

4217

QUALITY CONTROLLED CONTINUOUSLY FORMED NCF-PREFORMS

Arne Stahl, Henrik Borgwardt
Deutsches Zentrum für Luft- und Raumfahrt e.V. (DLR)

German Aerospace Center

Institute of Composite Structures and Adaptive Systems | Composite Design

Lilienthalplatz 7

38108 Braunschweig | Germany

ABSTRACT

Environmental and economic requirements call for lightweight aircraft design and for cost efficient manufacturing processes. Lightweight design can be reached by the use of composite materials, which have low specific weight. Carbon fiber reinforced polymers (CFRP) are especially suited for air frame production. Full exploitation of the composite's potential requires a specialized design. One aspect of such a design is a fiber orientation that accounts for the dimensioning load case. Regarding cost efficient manufacturing processes, resin transfer moulding (RTM) using low-cost non-crimp fabrics (NCF) is a very promising option. The preforming process is crucial for optimal and reproducible mechanical properties. Using a fuselage frame as an example, a novel approach of roll forming NCF into a complex curved profile is presented. The patented continuously working principle allows for accurate fiber orientation along the preform and offers a fast and flexible alternative to processes based on solid preform-tools. Automation not only provides cost-efficient processes but also leads to reproducible accuracies. Accompanied by an online quality assurance system that consistently measures the fiber orientation of each layer, the process meets high quality requirements. Inspecting all layers of a stacking enables a complete quality check in the preforming process.

1. INTRODUCTION

One goal of Flightpath 2050 [1] and the Air Transport Action Group ATAG is to reduce carbon emission by at least 50 % per passenger kilometer from 2005 to 2050. Also economic reasons ask for better exploitation of fossil fuels. Besides more efficient propulsion systems, optimized traffic control and electric ground taxiing, a reduced structural weight can support reaching this goal. A lower structural weight leads to higher payloads, in particular more passengers while the take-off weight stays the same, reducing the per-head emission.

The utilization of fiber composite materials shows great promise for achieving a lightweight aircraft design. The high potential of the composite can be fully exploited when design and manufacturing processes consider the material specific characteristics. Requirements for high performance composite aircraft structures include:

"Copyright 2014 by German Aerospace Center (DLR). Published by the Society for the Advancement of Material and Process Engineering with permission."

- a specific and constant fiber volume content
- flawless laminates
- correct fiber orientation: +/- 3° deviation
- straight aligned fibers without wrinkles
- undamaged fibers
- reproducibility

At the same time increasing aircraft production rates from thirteen to up to fifty aircraft / month [2] demands for efficient and reproducible processes. Resin transfer moulding (RTM) using relative low cost non-crimp fabrics (NCF) is a promising method. NCF offers fast lay-up rates due to 2D semi-finished goods instead of 1D rovings or tows and enables good draping characteristics due to customized stitching.

Aircraft parts have high quality requirements, thus manufacturing processes need to achieve high accuracies. For cost efficient production, scrap is fatal. Consequently a reproducible high quality process is needed.

Preforming represents a sub-step of an RTM process which is crucial for most of the requirements mentioned above.

This article focusses on a novel quality-controlled preforming process for the automated RTM production of aircraft fuselage frames from carbon fiber NCF.

2. AIRCRAFT FUSELAGE FRAME

The aircraft frame (Figure 1), as an example, is a curved profile with variable curvature and a C- or Z-cross section. The lay-up consists of carbon fiber NCF with biaxial, triaxial and unidirectional (UD) semi-finished goods.

UD-layers are positioned in both flanges as well as in the web. For the flanges a UD-band is used whereas the web requires a pre-manufactured curved UD-band as UD-material does not have the required draping capability. Within the laminate stacking UD-layers are equally distributed between biaxial and triaxial layers.



Figure 1. C-frame straight and curved

Due to the fact that UD is not drapable in terms of stretching in fiber direction, stack-wise forming is not possible. The area in and near the outer profile flange needs to be stretched. While

bidiagonal and tridiagonal NCF can be lengthened by shearing, a UD attached to the preform would constrain the deformation. So it is inevitable to form single layers for an aircraft frame lay-up prior to stacking.

3. EVO RTM PROCESS

Framework for the presented novel preforming process is the fully automated EVO RTM line (Figure 2) [3] which provides manufacturing capabilities for a production scenario of up to 100.000 frames per year. It consists of a material storage and feeding section which can handle six different textile material rolls to be fed to the CNC flatbed cutter. Complete ply cuts and local patch reinforcements are cut and transferred by a pick & place portal robot to an automatic shelf storage system. The pick and place handling steps are camera controlled for enhanced accuracy. In the preforming cell two different approaches are planned. The current status is based on proven preforming principles based on robotic handled sliding tools and forming of cut plies.



a) CNC cutter and ply handling portal robot

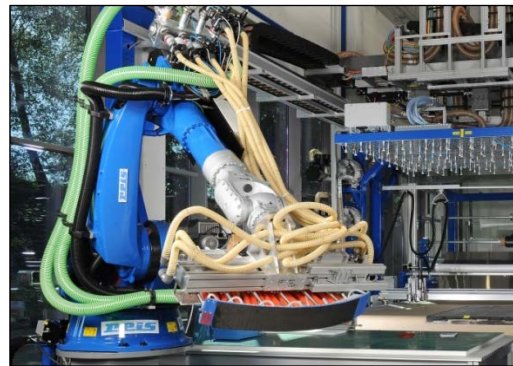

b) Draping robot



c) RTM tooling



d) RTM press and curing oven

Figure 2. Fully automated EVO RTM line

For forming an NCF-layer, a pre-cut ply is picked vacuum assisted from the drawer by the robot end-effector. It is transferred to the preform tool and clamped to the inner flange. A slider pushes

the ply from the inner flange to the outer flange while spreading the fibers to achieve a lengthened outer flange. NCF, UD-layers and local reinforcement patches are picked from the drawers and attached to the preform according to the designed stacking. For debulking the preform is placed in a hot membrane forming station. All layers are inspected by an eddy current based fiber orientation measurement system for quality insurance.

Sliding a solid tool over fibers may cause fiber damage. Areas near the free edges of cut plies naturally form differently than areas in the middle of the ply, which interferes with an evenly distributed fiber orientation along the frame.

After draping, stacking, debulking and ultrasonic fine trim the preform is transferred to the RTM tool for injection. The RTM tool is designed for fast processing and consists of fixed outer shells and a moveable shaping core which can be transferred to the following curing oven [4]. The continuous preforming facility presented in section 4.3 is designed to be an alternative preforming sub process to the robotic preforming approach in the EVo RTM line, overcoming the mentioned drawbacks of cut-ply based preforming.

4. QUALITY CONTROLLED CONTINUOUS PREFORMING PROCESS

The objective of the new quality controlled preforming process is to implement a method that addresses the most crucial issues arising with existing manufacturing methods.

4.1 State of Research: Aircraft Profile Preforming

Purol [5] describes a continuous preforming technique which uses NCF tapes. A complete frame lay-up is stacked from NCF and UD tapes. It is heated and formed to a C- or Z-section by passive forming rolls and bent into a curved profile by a link chain drive. Because of the insufficient draping capabilities of UD-material, this method is limited to lay-ups without UD-tapes in the outer flange and the web, which need to be formed. A real frame with UD in all areas of the lay-up cannot be formed.

Hermann et al. [2] presents a preforming technique that utilizes a wheel with an oval geometry like a fuselage cross-section. By rotating the wheel an NCF tape is formed into the Omega-shaped outer contour of the wheel. Due to the draping direction the technique is limited to profiles that are opened to the outer radius like Ω , L and Z.

A continuous preforming technique based on braiding is put forward by Gessler et al. [6]. It improves the waviness of braided preforms by replacing the fibers in one direction of the braided sleeve with very thin thermoplastic yarn. That creates a unidirectional layer. By braiding several layers with different orientations, a frame lay-up can be produced. Only closed sleeve-like geometries with convex sections can be braided. For open profiles like C-sections the sleeve needs to be cut. For Z-shaped sections the sleeve needs to be cut into two C-sections and one flange of the C needs to be folded by 180° to obtain a Z-section. Folding a multilayer preform can result in wrinkles in the folding radius.

Stroehlein et al. [7] describes a continuous pultrusion method for straight H-sections as joining profiles for sandwich structures. The method utilizes passive rollers and guide plates to form the profile. The material is pulled through the forming elements

A semi-continuous preforming method for straight H-sections with variable web height is presented by Borgwardt et al. [8]. The principle uses passive rollers and a moving roller-stand to form the variable profile section. The material is pulled through the forming elements.

4.2 DLR Continuous Profile Preforming Principle

A novel preforming process is designed. With this preforming principle it is possible to form NCF layers for realistic fuselage frame lay-ups. Complex shaped frame geometries with variable curvature can be formed continuously without deformations due to free-edge effects. Various cross sections like C-, Z-, L- or Ω -shapes are possible.

The process utilizes low-cost NCF bands for fast and cost-effective lay-up rates. A sensor controlled forming process with a fiber orientation measurement system is developed for reproducible preforms with damage-free fibers and an even fiber-angle distribution along the length of the frame.

Figure 3 shows the change of fiber orientation in a curved profile from originally $\pm 45^\circ$ in and near the inner flange to a sharper angle near the outer flange. The angle is measured against the circular 0° direction parallel to the flanges. This gradient is a consequence of the curved geometry.

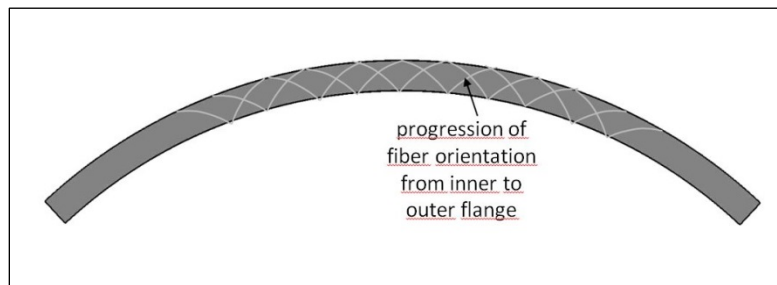

Figure 3. Progression of fiber orientation in a curved frame

The presented process is based on roll forming known from metallic profile fabrication which is proven for high quantities and efficient, precise and reproducible products. The patented continuous working preforming principle (Figure 4) developed at the DLR-Institute of Composite Structures and Adaptive Systems in Braunschweig / Germany [9] consists of three driven roll-pairs. More pairs for sequential forming and supporting the preform can be used.

Continuous preforming principles do not suffer from edge effects of cut plies. The fiber orientation is constant along the length of a formed profile. By using a roll forming principle there is almost no sliding between fibers and solid tools. So fiber damage is reduced to a minimum. This is supported by the use of silicone-coated rolls as can be seen in Figure 9.

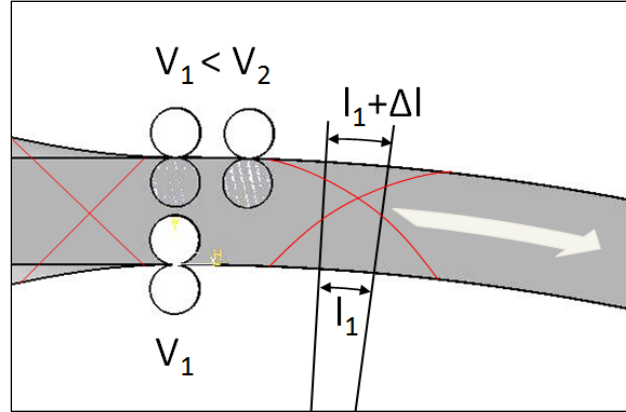

Figure 4. Preforming principle with fiber orientation in red

The flat NCF band is pre-formed to a C-profile prior to adding curvature to the sub-preform. For forming the profile to a curvature both flanges of the profile are transported between two counter-rotating rolls with speed v_1 . At the outer flange a second pair of rolls rotates with a differential speed v_2 to shear the outer flange and the adjacent outer web. By shearing the NCF from $\pm 45^\circ$ to a sharper angle it is elongated by Δl and thus adds a curvature to the profile.

The length difference is linked to the outer radius r , width / web height b of the circular profile and the speeds v_1 and v_2 :

$$\frac{v_2}{v_1} = \frac{l_1 + \Delta l}{l_1} \quad [1]$$

$$\frac{r}{r - b} = \frac{l_1 + \Delta l}{l_1} \quad [2]$$

With these equations [1] and [2] the elongation of the outer flange can be determined to:

$$\varepsilon = \frac{\Delta l}{l} = \left(\frac{r}{r - b} \right) - 1 = \frac{v_2}{v_1} - 1 \quad [3]$$

Figure 5 shows the elongation in the outer flange of a circular curved frame for an assumed profile width / web height b of 140 mm plotted against the outer frame radius.

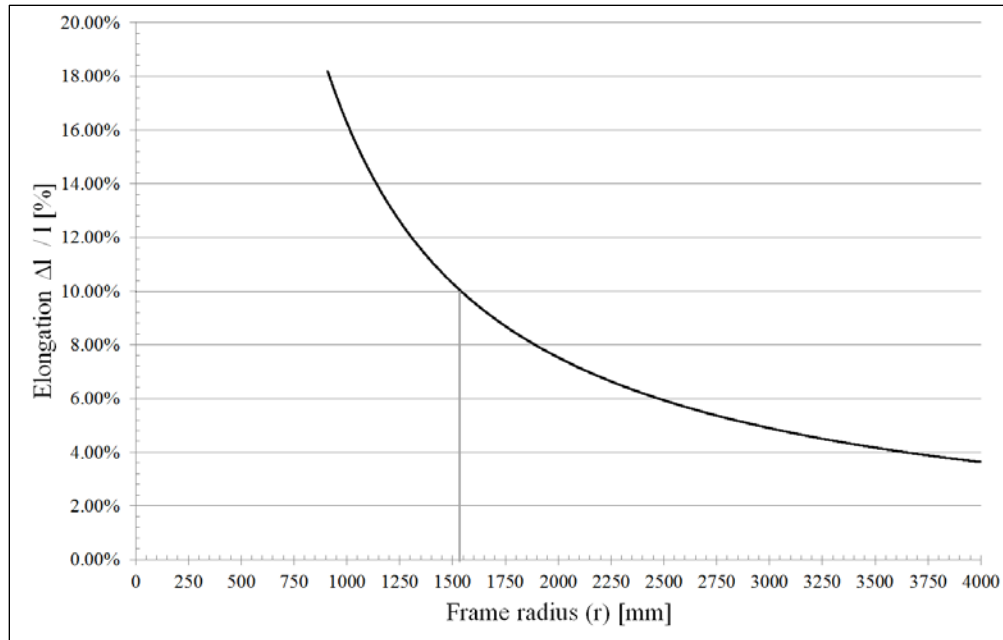

Figure 5. Elongation of outer flange for different outer radii (web height 140 mm)

The presented preforming principle allows manufacturing profiles with variable curvature. By altering the speed difference during manufacturing the elongation is changed which results in a changed curvature.

4.3 Continuous Profile Preforming Facility

The principle was proven in a test-rig and adapted in a modular prototypic preforming facility (Figure 6) consisting of a storage unit, transport unit, forming unit, sensing equipment and control unit.



Figure 6. DLR continuous profile preforming line

The storage unit (Figure 7) can take up one roll of pre-configured NCF band. The reel sits on a driven shaft that unwinds the material in a loop without any tension in the NCF material. A sensor controls the loop length and the unwinding speed.

The transport unit (Figure 8) consists of two drive belts that are divided in three bands with individual lengths. Both belts work like a belt press and transport the material in an adjustable gap between the belts damage-free from storage to forming. The exit of the unit is formed to allow the NCF band to be pre-formed to the designed cross section. Only the web area is still clamped and transported.

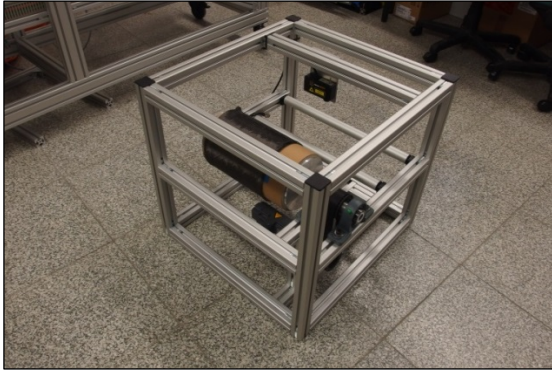

Figure 7. Storage unit

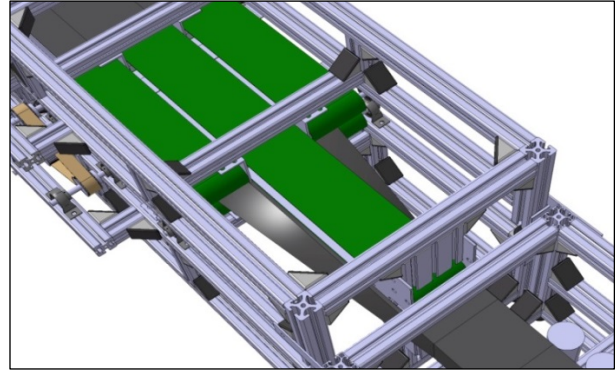

Figure 8. Transport unit

The forming unit (Figure 9) consists of five pairs of driven and counter rotating rollers. The rollers are silicone rubber coated for gentle fiber handling and non-slip characteristics. At the upper edge the rollers have a collar for precise radius forming between flanges and web. Each pair of rollers is mounted in a separate housing, has an adjustable gap between the rollers and is driven by a separate electric drive. This way each pair can be driven independently to control the amount of shear brought in the NCF material. Due to the modular design the separate roller pairs can be mounted in different configurations to form C- Z- L- or Ω -profiles (Figure 10).



Figure 9. Forming unit with FScan sensor for fiber orientation measurement

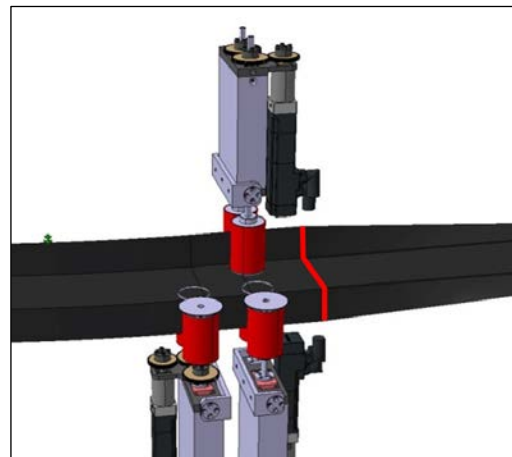

Figure 10. Forming unit Z-configuration

UD layers in the flanges can be attached to the formed layer in the forming unit. After the preforming of single layers these sub preforms can be stacked by a robotic handling effector to

the designed lay-up. The control unit contains the power and control elements for individual control of the installed drive systems. An industry PC is installed for operating, sensing and visualization tasks.

4.4 Fiber Orientation Measurement

A fiber orientation measurement sensor based on image processing is presented by Schmitt et al. [10]. It consists of a camera and a diffuse illumination source. Images taken by the camera are analyzed regarding grey value distribution to obtain a fiber direction. The method is very light sensitive as carbon fiber surfaces are very reflective and reflections disturb the grey scale analysis. Image processing is computing intensive and best suited for analysis of sequential measurements.

Heuer et al. [11] present a system based on multi-frequency eddy current for the detection of fiber orientation and defects in the composite material. The sensor is capable of inspecting hidden layers under the actual top layer. By 2D Fourier Transformation and image processing fiber orientations of the scanned layers can be calculated. Currently detection and analysis of fiber orientation takes several seconds for each measurement.

The sensor used for fiber orientation measurement (Figure 9) in the preforming process is based on Fiber Reflection Analysis (Figure 11) [12].

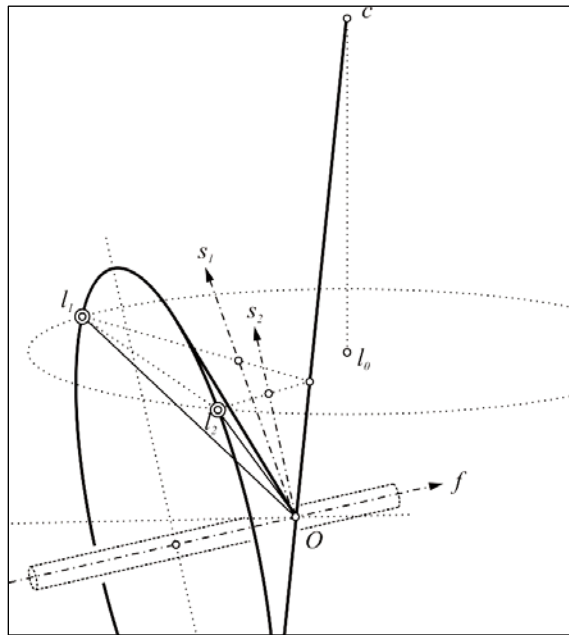

Figure 11. Fiber Reflection Analysis [12]

The principle uses the assumed cylindrical fibers as a reflector. The reflection of a single ray encountering a cylinder is a cone. A ray of light sent out from two known positions (l_1 and l_2) in a LED light ring intersecting the reflection cone of the carbon fiber are reflected from the fiber (point O on fiber f) in one pixel of a camera sensor (point c). With the known positions the angle of the fiber against the sensor can be calculated. The measurement system is robust against

interfering light and can operate in real time scan-mode because of its very fast detection and analysis rate of up to 1000 frames/s. With this sensor it is possible to obtain data enabling the analysis of the forming mechanism and the resulting NCF deformation for validation and quality assurance reasons.

5. VALIDATION OF OPERATION MODE

For validating the operation mode of the preforming facility a test series is carried out. The test is designed to analyze the amount of elongation induced by the rollers and to compare the results with the calculated elongation values and the measured fiber orientation.

The specimens for the test are strips of bidiagonal NCF (Table 1, Figure 12) with a length of 1500 mm and a width of 55 mm. Contrasting points with a constant distance of 20 mm are attached to the strip for the determination of the elongation during forming.

Table 1. NCF data - toughened bidiagonal non-crimp fabric

Manufacturer's style or fabric ID	
Type of Textile	Bidiagonal Non-Crimp Fabric
Textile areal weight	415 g/m ² ± 20 g/m
Carbon fiber areal weight	388 g/m ² ± 19 g/m ²
Fibers	Tenax®-E IMS65 E23 12K 830tex
Toughener	TA1900c2
Powder Binder	EP 05311
Stitching yarn	CoPA
Weave	Tricot-Pillar
Stitching length	2.2 mm

NCF strips are conveyed through three pairs of rollers in a row (Figure 14). The speed ratio takes effect between the first two pairs to induce the elongation. The second and third pairs rotate with the same speed to secure the elongation for measurement.



Figure 12: Samples of NCF weft side (left) and warp side with toughener (right)

The speed ratio is adjusted as follows:

$$\frac{v_2}{v_1} = \frac{5.5 \frac{mm}{s}}{5 \frac{mm}{s}} = \frac{1.1}{1} \quad [4]$$

The expected elongation is calculated from equation 3:

$$\varepsilon = \frac{v_2}{v_1} - 1 = 0.1 \quad [5]$$

Taking the “fishnet” model of Van West [13] (Figure 13) as an assumption for the draping mechanism, the theoretical fiber angle change $\Delta\alpha$ for a given elongation of $\varepsilon = 0.1$ can be calculated.

$$2L = 2K \cdot \cos(\alpha_0) \quad \text{and} \quad 2L(1 + \varepsilon) = 2K \cdot \cos(\alpha^*) \quad [6]$$

$$\cos(\alpha^*) = (1 + \varepsilon) \cdot \cos(\alpha_0) \quad [7]$$

$$\alpha^* = \arccos \{(1 + \varepsilon) \cdot \cos(\alpha_0)\} \quad [8]$$

$$\alpha^* = \arccos \{1.1/\sqrt{2}\} = 38.93^\circ \quad [9]$$

$$\Delta\alpha = \alpha_0 - \alpha^* = 6.07^\circ \quad [10]$$

This value $\Delta\alpha$ is used for validating the amount of shear induced by the rollers. However the “fishnet” model is based on the assumption that no inter-ply slippage occurs and fibers are linked at the crossing points. Hence there can be a difference between theoretical and experimental values.

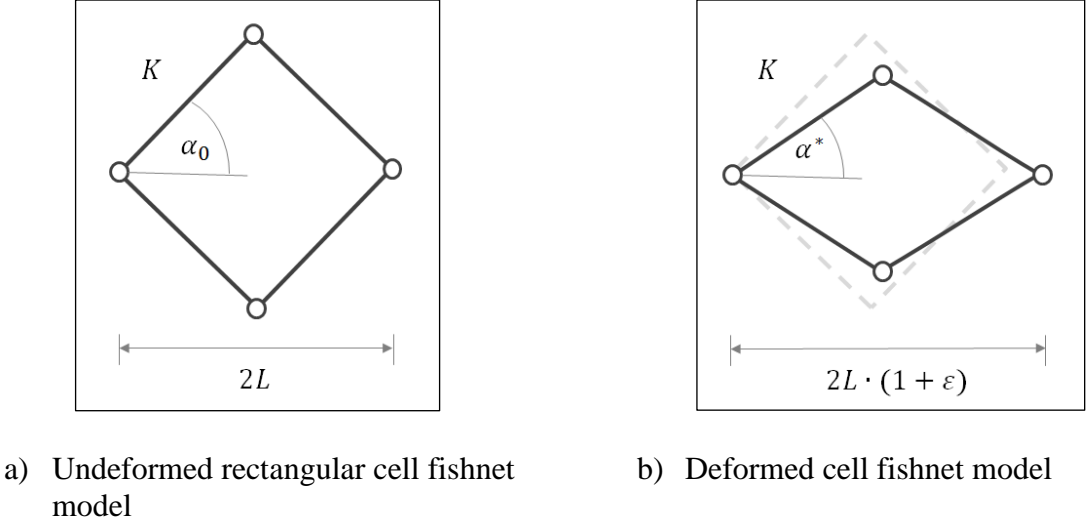

Figure 13: Fishnet model of a textile material

Prior to the test, the fiber orientation at each measurement point is taken with the FScan sensor. The test is carried out with a machine speed of 5 mm/s. The NCF stripe is conveyed and sheared by the first two roller pairs. For each measurement point reaching the measurement position in front of the sensors between the second and the third roller pair the machine is stopped. Photos are taken from the marked material to measure the point distance after forming. With the FScan sensor the fiber orientation is measured simultaneously at the same position (Figure 14).

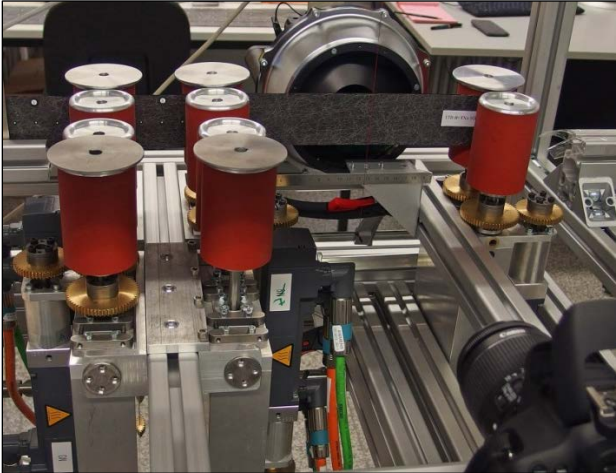

Figure 14. Elongation test setup

Both elongation determined from distance measurement of the attached markers and the change of fiber orientation before and after forming are plotted in one chart (Figure 15) against the travelled length of the NCF specimen SD2 in the preforming facility.

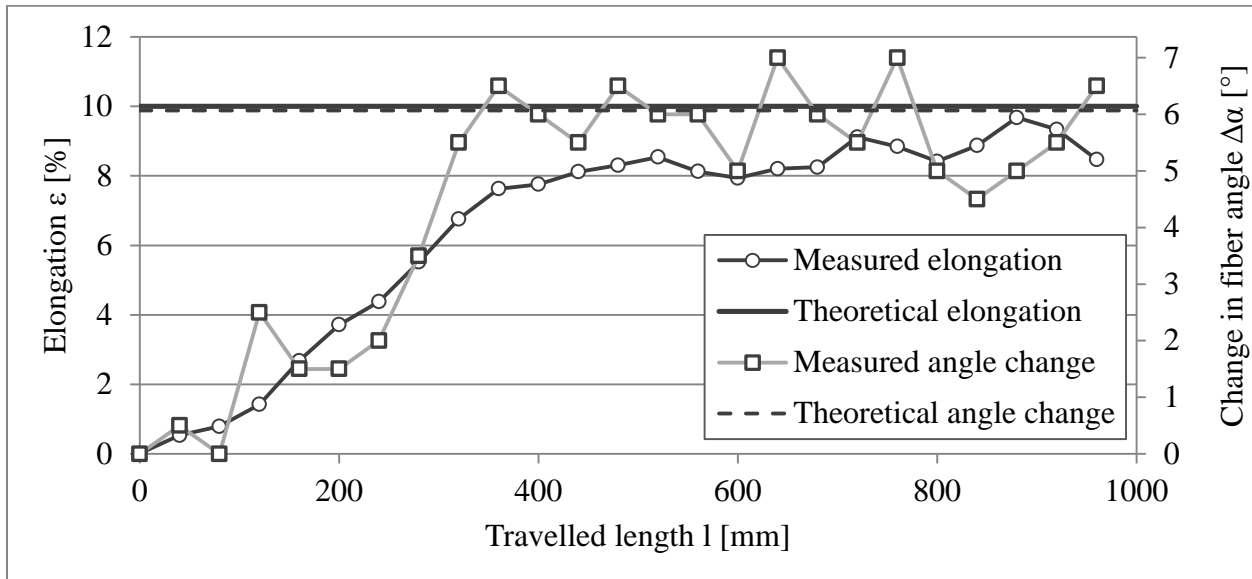

Figure 15. Test results specimen SD2

One can see that the realized elongation as well as the induced fiber angle change show asymptotic behavior. The achieved fiber angle change is varying around the theoretical value $\Delta\alpha = 6.07^\circ$. However the achieved elongation is about one point less than the expected 10%. Occurring deviations can be traced back to roller-slippage during the elongation of the material, relaxation of the material after passing the second roller pair and the assumptions of the fishnet model. Consequently, an off-set speed needs to be adjusted in subsequent tests in order to compensate those affectations.

Figure 15 shows basically matching curves with significant variations in the fiber angle difference. The measurement systems accuracy of 0.5° is one reason and the material inherent variations are remarkably high. So the initial angle of the “+/-45° bidiagonal NCF” was measured to an average of 47.5° varying from 46.5° to 48.5° . So an average deviation of less than +/- 1° is well within the requirements of +/- 3° .

The calculated elongation of 10% is not completely achieved. An asymptotic behavior towards 10% due to adulterating effects such as slip and relaxation can be seen.

Due to limited specimen length the data for following positions are missing. Further investigations are planned. With the knowledge of a specific reproducible off-set in the achieved elongation and the resulting curvature the process can be adjusted to the correct curvature.

6. SUMMARY AND OUTLOOK

A novel flexible roll forming based preforming approach for aircraft fuselage frames from carbon fiber NCF is presented. The main innovation is the flexibility of the process. C- and Z-

profiles with variable curvature can be formed by variable roll speeds reproducibly shearing the NCF. A single NCF-layer preforming approach is pursued because non-formable UD tapes are commonly required in lay-ups of circumferential frames. A fiber orientation measurement system is implemented to qualify the process and log the quality during manufacturing. Experimental investigations prove the concept of forming NCF material by roller pairs with differential speeds. The achieved elongation is only 10 % less than the calculated value. As expected there are deviations due to the inevitable slip and relaxation effects. Nevertheless the local deviation of fiber orientation is within the required limits.

Further investigation needs to be carried out to gain data about a potential off-set between the achieved and the designed elongation and curvature. Next steps will see further elongation tests and a full profile test series.

The implementation of a fiber orientation measurement sensor in a continuous preforming facility puts the authors in a position to scan complete NCF layers of a frame preform. The distribution of fiber orientations and the change of orientations along the web-height can be converted into a mesh that enables the as-built FE simulation of the frame with realistic orientations and the validation of draping simulation methods. This can overcome the drawbacks of idealized assumptions in the design process.

7. REFERENCES

- [1] "Flightpath 2050 Europe's Vision for Aviation." European Union. Publications Office of the European Union. *Policy*, Luxemburg; 2011.
- [2] Herrmann, A. & Witte, T. "Continuous production of highly complex carbon fibre preforms." *Aachen-Dresden International Textile Conference*, Aachen; 29.11.2013.
- [3] Torstrick, S., Kruse F. & Wiedemann M. „RTM-Processing for Net Shaped Parts in High Quantities." *CFK-Convention*, Stade; 12.06.2013.
- [4] Hindersmann, A., Exner, W., Liebers, N., Opitz, M., Torstrick, S. & Ucan, H. „Forschungsplattform für endkonturnahe Faserverbundbauteile im automatisierten Fertigungsprozess." *Deutscher Luft- und Raumfahrtkongress 2012*, DGLR, Berlin; 10.09.2012.
- [5] Purol, Holger. „Entwicklung kontinuierlicher Preformverfahren zur Herstellung gekrümmter CFK-Versteifungsprofile." PhD thesis, University Bremen; 2011.
- [6] Gessler, A & Meidl, F. Patent. DE102004017311B4. „Verfahren zur Herstellung eines Bauteils in Faserverbundbauweise mittels Rundflechttechnik." 29.03.2012.
- [7] Stroehlein, T., Niemann, S., Frauenhofer, M., Herbeck, L. & Dilger, K. "Continuous inductive Preforming for RTM-Production" *CFK Convention*, Stade; 26.06.2008.
- [8] Borgwardt H. & Huehne, C. „Automated continuous preforming of profiles with variable web height adjustment." *Aachen-Dresdner International Textile Conference*, Aachen; 29.11.2013.
- [9] Stahl, A., Borgwardt, H. & Assing, H. Patent. DE102012101706A1. "Gekrümmte Preform." 05.09.2013.

- [10] Schmitt, R., Pfeifer, T. Mersmann, C. & Orth. A “A method for the automated positioning and alignment of fibre-reinforced plastic structures based on machine vision.” *CIRP Annals - Manufacturing Technology*. Volume 57, Issue 1, 2008: Pages 501–504
- [11] Heuer, H. & Schulze, M. H. “Eddy Current Testing of Carbon Fiber Materials by High Resolution Directional Sensors.” *Conference for Smart Materials, Structures & NDT in Aerospace*. Montreal; 2011.
- [12] Palfinger, W., Tumfarth, S. & Eitzinger, C. “Photometric stereo on carbon fiber surfaces.” *35th Workshop of the Austrian Association for Pattern Recognition*, Graz; 26.11.2011
- [13] van West B. P., Pipes, R. B. & Keefe, M. “A Simulation of the Draping of Bidirectional Fabrics over Arbitrary Surfaces.” *Journal of The Textile Institute*, Volume 81, Issue 4, 1990: Pages 448-460