

THE COLOUR AND STEREO SURFACE IMAGING SYSTEM (CaSSIS) FOR ESA'S TRACE GAS ORBITER. N. Thomas¹, G. Cremonese², M. Banaszekwicz³, J. Bridges⁴, S. Byrne⁵, V. da Deppo⁶, S. Debei⁷, M.R. El-Maarry¹, E. Hauber⁸, C.J. Hansen⁹, A. Ivanov¹⁰, L. Kestay¹¹, R. Kirk¹¹, R. Kuzmin¹², N. Mangold¹³, L. Marinangeli¹⁴, W. Markiewicz¹⁵, M. Massironi¹⁶, A.S. McEwen⁵, C. Okubo¹¹, P. Orleanski³, A. Pommerol¹, P. Wajer³, and J. Wray¹⁷. ¹Physikalisches Inst., University of Bern, Sidlerstrasse 5, CH-3012 Bern, Switzerland (nicolas.thomas@space.unibe.ch), ²INAF, National Institute for Astrophysics, Padova, Italy, ³Space Research Center, Polish Academy of Science, Warsaw, Poland, ⁴University of Leicester, Leicester, UK, ⁵Lunar and Planetary Laboratory, Tucson AZ, USA, ⁶CNR-IFN UOS Padova, Italy, ⁷Centro Interdipartimentale di Studi e Attività Spaziali, Padova, Italy, ⁸Deutsches Zentrum für Luft- und Raumfahrt, Institut für Planetenforschung, Berlin, Germany, ⁹Planetary Science Institute, St. George, Utah, USA, ¹⁰École polytechnique fédérale de Lausanne, Lausanne, Switzerland, ¹¹USGS, Astrogeology Science Center, Flagstaff AZ, USA, ¹²Vernadsky Inst. of Geochemistry and Analytical Chemistry of Russian Academy of Science, Moscow, Russia, ¹³Université de Nantes, Nantes, France, ¹⁴IRSPS - Università "G.D'Annunzio", Pescara, Italy, ¹⁵Max-Planck-Institut für Sonnensystemforschung, Göttingen, Germany, ¹⁶Dep.Geosciences, University of Padova, Padova, Italy, ¹⁷Georgia Inst. of Technology, School of Earth and Atmospheric Sciences, Atlanta GA, USA.

Introduction: CaSSIS (Colour and Stereo Surface Imaging System) will be the main imaging system for the ExoMars 2016 Trace Gas Orbiter (TGO) mission. Although loosely based upon the HiSCI instrument (which was originally selected for TGO) the required short-term availability of sub-systems for CaSSIS has led to considerable changes to the original (HiSCI) concept. However, a viable and scientifically compelling instrument is now in the build phase with a target completion date of Sept. 2015 for a launch in Jan. 2016. This abstract describes CaSSIS and its capabilities.

Science Objectives: The scientific objectives are (1) to characterize sites which have been identified as potential sources of trace gases, (2) to investigate dynamic surface processes (e.g. sublimation, erosional processes, volcanism) which may help to constrain the atmospheric gas inventory, and (3) to certify potential future landing sites by characterizing local (down to ~10 m) slopes.

Technical Aims: The basic technical aims are (1) to acquire imaging observations at a scale of < 5 m/px, (2) to produce images in at least 3 broad-band colours optimized for Mars photometry, (3) to acquire a swath width >8 km, and (4) to obtain quasi-simultaneous stereo pairs over the full swath width for high resolution digital terrain models. These technical aims combined with programmatic constraints have driven the instrument design.

Instrument Design: Detector. The instrument properties are centred on use of a focal plane system which is a spare from SIMBIOSYS. SIMBIOSYS is slated to fly on ESA's BepiColombo mission to Mercury in July 2016. The detector is a Raytheon Osprey 2k CMOS hybrid comprising 2k x 2k pixels with 10 µm pitch which allows snapshot operation at a read-out rate of 5 MPixel/s with 14 bit resolution. CaSSIS will operate in the push-frame mode with this system.

Filter strip assembly (FSA). The FSA is placed directly above the detector surface. Here the

SIMBIOSYS design has been changed to utilize filter wavelengths and bandwidths that are optimum for Mars while obtaining high signal to noise.

Telescope characteristics. A trade-off exists between the resolution, the instrument mass and volume, and the exposure time necessary to avoid smear. We have chosen a 880 mm focal length, F/6.5 system, which, in combination with the selected bandwidths in the FSA, results in good signal to noise (SNR) in all colours at a pixel scale of 4.6 m/px in the 400 km circular (baseline) orbit (Figure 1). The resulting system has a mass of 17.7 kg and just fits into the space available on the TGO platform. The telescope is based on a three-mirror plus fold mirror off-axis design but has a powered fourth mirror allowing use of a previously manufactured 13.5 cm primary. The mirrors use a space-qualified protected silver coating. The system has relatively little distortion (<2%) and a worst case modulation transfer function (MTF) of 0.3 at Nyquist. The telescope is made from Carbon Fiber Reinforced Plastic (CFRP) for low thermal expansion.

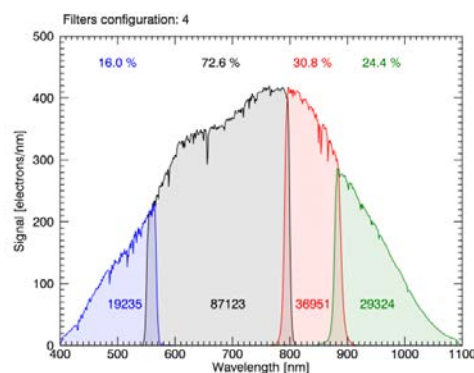

Figure 1 The wavelengths and bandwidths for the CaSSIS system. The percentage to full-well in each filter during a 1.5 ms exposure is indicated for each filter.

Rotation Mechanism. The TGO spacecraft design and its method of orienting its solar arrays leads to the need for a rotation mechanism to orient the instrument so that image rows are perpendicular to the orbital

track. This mechanism can also be used to support generation of quasi-simultaneous stereo imaging by mounting the telescope pointing forward along-track from the nadir direction and rapidly rotating the telescope by 180° as the spacecraft flies over a target. The telescope pitch angle is 10° , which leads to a stereo convergence angle of 22.4° when planetary curvature is accounted for. The time between stereo points from the nominal orbit is 46.9 s. Hence a 180° rotation is needed within ~ 15 s. This is achieved using a stepper motor (Portescap; Turbodisc P430) with modified ceramic bearings which drives a worm gear via a flexible bellow-type coupling. The motor is the same as that used in the scanner of ASPERA-4 on Venus Express. The custom-designed bearings support the hollow and worm shaft of the mechanism. Silicon nitride was chosen for its outstanding dry-run properties and low density. No lubrication requirement is foreseen. The chosen reduction ratio for the gear is 200:1. All gear components are made of high strength titanium alloys (Ti 6246 and Ti Beta-C) and are hard-coated for low friction and wear resistance.

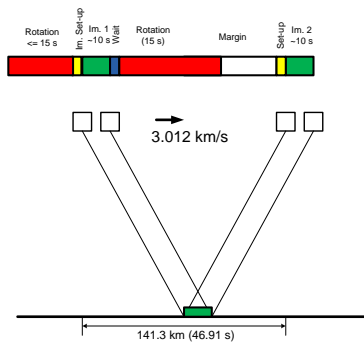

Figure 2 Stereo geometry for CaSSIS

Proximity Electronics (PE). The proximity electronics to support the detector are mounted inside the rotation bearing – an important feature of the structural design – and are also based on SIMBIOSYS.

Cable Management System. The twisting of the cables because of the rotation must be taken into account. A dedicated cable holder which allows this motion before passing signals through semi-rigid cables to the electronics box (ELU) has been foreseen.

CRU Structural Design. The Camera Rotation Unit (CRU) is based around a T-like structure with the optics and focal plane assembly to the right of the main support and the PE within and to the left of the central support. The two items balance across the support, which also contains the rotation mechanism. The balanced mass across the mount avoids the need for launch locks and/or bridge structures (which incur significant mass penalties). It should be noted that this

configuration gets most of the focal plane electronics away from the telescope and thus has the advantage of simplifying the telescope and all internal interfaces.

ELU. An instrument ELU comprising a power converter and a digital processing module (DPM) completes the system. The DPM uses a radiation-hard Dual-Core GR712RC LEON 3FT SPARC V8 Processor. The DPM will run a CCSDS (Consultative Committee for Space Data Systems) compression software with typical compression ratios of 6-8 in flight. To prevent inducing excessive thermoelastic stresses into the spacecraft panel, an intermediate decoupling plate was implemented at the mechanical interface. The plate consists of a sandwich panel with aluminium honeycomb core and near-zero coefficient of thermal expansion CFRP facesheets.

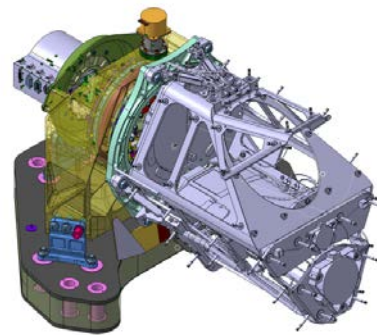

Figure 3 The CaSSIS Camera Rotation Unit (CRU)

Table 1 Hardware development team

University of Bern	Overall lead, telescope, structural mechanics, DPM
INAF-Osservatorio d' Astronomico, Padova	Focal plane sub-system and proximity electronics
Space Research Center, Warsaw	Power converter module
TU Braunschweig	Compression software

Software and Operations: The CaSSIS team will support the development of a public target suggestion database following the successful implementation of HiWISH for HiRISE. The nominal data volume allocated is 2.9 Gbit/day. Each (colour) sub-exposure on the detector can be individually commanded for swath width and binning allowing typically 6-8 stereo pairs per day plus additional single image frames of lower priority targets. Current models indicate that 3.4% of Mars will be covered in colour and 1.7% in stereo during the prime mission (1 Mars year) at 5-10 m/px.

Acknowledgments: This work is supported by the Swiss Space Office through the ESA PRODEX programme.