

GALANT – Galileo Antenna and Receiver Demonstrator for Safety-Critical Applications

M. Cuntz¹, A. Konovaltsev, A. Hornbostel, E. Schittler Neves, A. Dreher

*Institute of Communications and Navigation, German Aerospace Center (DLR)
Oberpfaffenhofen, D-82234 Wessling, Germany*

¹Manuel.Cuntz@dlr.de

Abstract — The DLR Institute of Communications and Navigation has started to develop an antenna and receiver demonstrator, called GALANT. This paper provides an overview about the structure and the main objectives of the demonstrator development.

I. INTRODUCTION

Future navigation services and performance limits provided by the upcoming Galileo satellite system will require corresponding improvements of the user navigation receiving systems. Therefore, the Institute of Communications and Navigation of the German Aerospace Center originated the development of a Galileo Receiver Demonstrator (GALANT). The aim is to develop a complete Safety-of-Life (SoL) Galileo receiver system. For SoL applications, interference and multipath signals can cause serious performance degradations, which cannot be tolerated. Advanced signal-processing algorithms including antenna array techniques like digital beam-forming will contribute to overcome this problem by suppressing interference and multipath signals and improving the reception of useful line-of-sight satellite signals and thus enable a more accurate and reliable positioning.

The first part of this paper describes the antenna array and the basic design issues. The second part is a short discussion of the front end concept utilized for the demonstrator. Subsequently, the basic digital receiver design is discussed. Finally, a brief overview of the digital beam-forming and direction finding techniques used for the demonstrator is given.

II. ANTENNA ARRAY

Ideally, the perfect antenna array element would present a symmetric radiation pattern with perfect right-hand circular polarization (RHCP) in the complete hemisphere for the whole frequency band, and would provide a constant gain for any direction subjected to a beam steering operation. However, in practical terms this scenario becomes much different. The development of a broadband antenna with symmetrical radiation pattern and high polarization purity is a very challenging task [1]. To attain an application-oriented technology demonstrator, realistic but tough specifications were set in order to achieve the best possible overall performance.

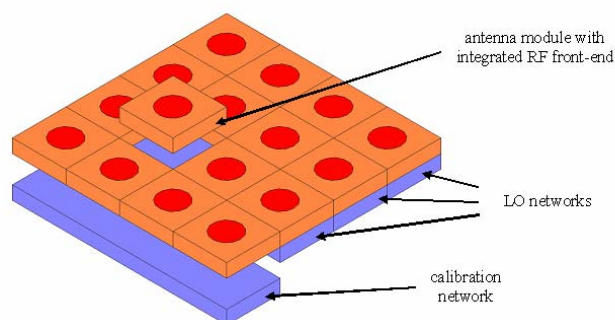

Fig. 1 Schematic of antenna array

The main requirements are listed below:

- Bandwidth: 1164 MHz to 1591 MHz (31 %)
- Return Loss: -10 dB min.
- Polarization: RHCP
- Azimuth scanning capabilities: 360°
- Elevation scanning capabilities: from 0° to 90°
- Gain: 10 dBi min. over all scan angles between 30° and 90° elevation, (elevation angle is counted with respect to horizontal plane).
- Axial ratio: 3 dB min. over all scan angles (30° to 90° elevation)
- Cross-polarization suppression: 15 dB min., 25 dB or better is desirable

A very important constraint for the antenna array is its physical size. Although it is not explicitly listed in the requirements above, the overall size must be as small as possible in order to make it suitable for mobile applications. The goal was set not to exceed 50 x 50 cm². This means, considering that the distance of the L-band elements should be about one-half wavelength at centre frequency, that the antenna array can have 25 elements in a 5 x 5 element configuration at the most. (At the considered GPS/Galileo frequency band the wavelength is around 20 cm). With such a small number of array elements it is not possible to precisely steer the beams towards very low elevation angles. As a matter of fact, the beam pointing keeps relatively good for elevation angles of 30° or higher.

For lower elevation angles, the incoming signals must be received by a portion of the radiation beam which does not point in the direction of maximum gain. In this case the reception characteristics will degrade as the elevation angle becomes smaller. In [2], a performance comparison between two antenna arrays, one having 4 x 4 elements and the other 5 x 5 elements was made and it was found that for small elevation angles there are no significant differences. Therefore, an antenna array of 4 x 4 elements was chosen because it is smaller, its number of elements is more suitable for digital signal processing and its radiation properties are nearly as good as that of a 5 x 5 array.

The antenna array is planned to be completely modular. Fig. 1 illustrates this concept by showing in a very simplified way the antenna modules and the local oscillator (LO) modules. Taking into account that each single antenna module measures 95 mm x 95 mm, the total size of the array surface is 38 cm x 38 cm.

III. RECEIVER FRONT END

A splitter separates the received, pre-amplified signal of each antenna element into three parts E5, E6 and E1 of which each is processed by a different front end (Fig. 2).

A. RF stage

The first part of each front end is a RF band-pass filter in order to suppress the out-of-band signals. Subsequently the signals are amplified by two RF amplifiers before they are down converted to IF.

B. IF Stage

By the mixing process the frequencies symmetrical to the local oscillator frequency (LO) are transformed to IF. Although the unwanted frequency bands are suppressed by the RF band-pass filter, a strong interferer might still have an intense impact. Therefore, the downconversion of the GALANT front end is done by image-reject mixers which suppress the mirror frequencies by more than 35 dB, i.e. with an out-of-band attenuation by the filters of more than 55 dB,

overall, these unwanted images are suppressed by more than 90 dB.

After the analog down conversion the signal is amplified by a variable-gain amplifier before entering the anti-aliasing low-pass filter. An automatic gain control is used to compensate the temperature drift of the amplifiers and to cope with in-band interferers.

The anti-aliasing filter is carefully designed to keep the differential group delay, insertion loss and in-band ripple as low as possible and to achieve a difference between pass band and stop band of more than 40 dB to prevent aliasing.

C. Analog to digital conversion

The analog-to-digital conversion is performed by a standard low-pass sampling approach. The sampling frequency is set to $f_s = 4 \cdot f_{IF}$. This simplifies the I/Q-demodulation in the digital domain and gives sufficient spectral distance for a feasible anti-aliasing filter.

The analog IF-data are digitised with 12 bit resolution and 250 MSPS. Afterwards the digital data is transferred to the digital receiver board via a LVDS interface. The 12 bit resolution provides a high dynamic in order to cope with the relatively high power of potential interferers compared to the Galileo/GPS signals.

IV. DIGITAL RECEIVER

The digital receiver will perform acquisition and tracking of the navigation signals. For this purpose, the correlations of the received signals with local reference codes for each satellite and each frequency band along with code and carrier tracking loops have to be implemented. Also the digital beam-forming will take place here. The idea of GALANT is to perform beam-forming after correlation, the correlation has to be done for each antenna element. Hence, the total number of correlators is the product of the required correlators for a single antenna channel multiplied with the number of antenna elements M

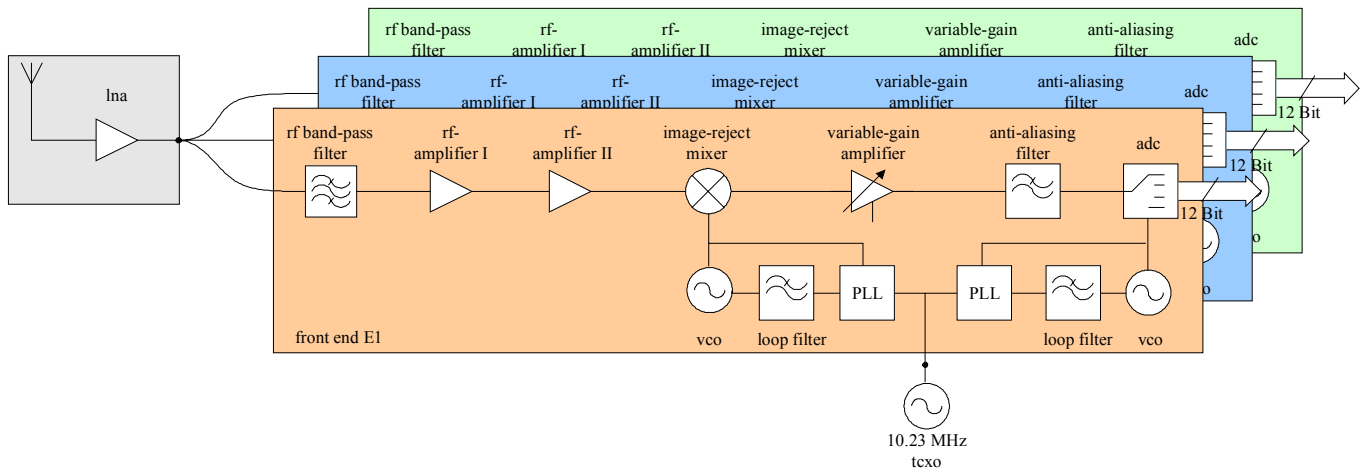

Fig. 2 Block diagram of the receiver architecture

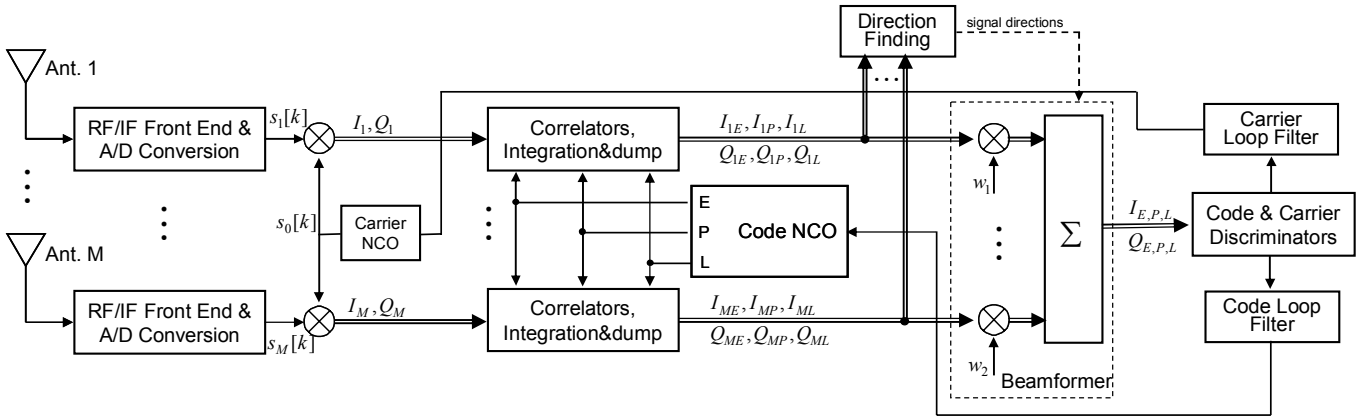

Fig. 3 Block diagram of digital beam-forming after despreading of Galileo ranging codes

(compare Fig. 3 and Fig. 4). These correlators will be implemented in FPGAs for enabling real time operation. After correlation, the despread signals from the individual antenna elements will be combined by the digital beam-forming process, so that at the output of the digital receiver the number of channels is reduced by the factor M .

The digital receiver will have an interface with a software receiver (SW-Receiver in Fig. 4), which will process the collected observables like correlator outputs (denoted $I_{E,P,L}$ and $Q_{E,P,L}$ in Fig. 3), phase of reference PRN code, carrier phase at low data rates, and therefore, can be implemented in a PC or Notebook. The SW-Receiver is responsible for the navigation solution and integrity processing, but may also include some parts of the digital receiver. Therefore, two options will be investigated: 1. implementation of the whole tracking loops in FPGA or 2. closing of the tracking loops in the SW-receiver. The second option needs a bi-directional interface to the FPGA part, but offers higher flexibility and the possibility to implement the whole beam-forming process in the SW-receiver. The complete demonstrator architecture is shown in Fig. 4.

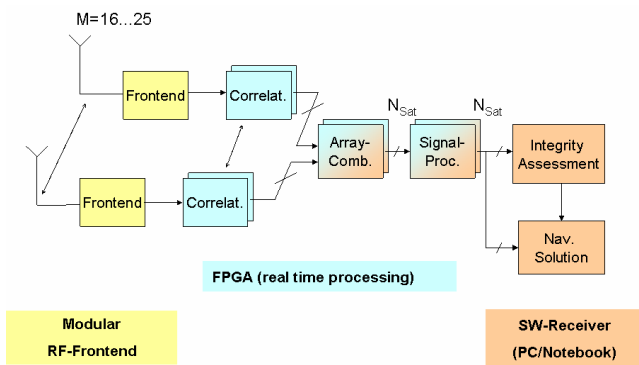

Fig. 4 GALANT architecture

V. DIGITAL BEAM-FORMING

The digital beam-forming technique is used in each of N_{sat} digital-processing branches (see Fig. 4) for steering the main lobe of the antenna array towards the corresponding navigation satellite and placing nulls in the directions of arrival of unwanted signals like radio interferers and multipath echoes. In order to correspondingly shape the array pattern, the digitised array signals are weighted using a set of complex beam-forming coefficients that is specific in each receiver branch. The beam-forming process is assumed to be controlled by the linearly constrained minimum variance (LCMV) algorithm. The directional information about arriving signals that is required to produce constraints in the LCMV algorithm is provided by one of the following direction of arrival (DOA) finding methods: ESPRIT (Estimation of Signal Parameters via Rotational Invariance Techniques) and MUSIC (Multiple Signal Classification). The Galileo satellite signals are received deeply under the noise floor. Under these conditions the direction finding algorithms either cannot be used in realistic hardware configurations or deliver very noisy estimations. Therefore in the demonstrator a despreading process is accomplished that takes place in the phase and code-phased lock loops (PLL/DLL) of the receiver signal-tracking unit. The DOA estimators are operating on the outputs of PLL/DLL correlators as shown in Fig. 3 [3].

REFERENCES

- [1] E. S. Neves, P. de Vita and A. Dreher, "Modular smart antenna array for GPS and Galileo applications", *European Navigation Conference ENC-GNSS 2005*, Munich, July 2005. (12 pp. CD-ROM) Proceedings GNSS 2005.
- [2] E. S. Neves, P. de Vita and A. Dreher, "Smart antenna arrays for GPS and Galileo applications," *2nd ESA Workshop on Satellite Navigation User Equipment Technologies*, Noordwijk, The Netherlands, Dec. 2004, (8pp. CD-ROM).
- [3] A. Konovaltsev, B. Belabbas, H. Denks and A. Hornbostel, "Adaptive antenna against multipath," *Proc. of the 8th European Navigation Conference GNSS 2004*, Rotterdam, The Netherlands, May, 2004.