

A centrifugal lab-on-a-disc device for the *in situ* determination of dissolved reactive phosphate in water



Gillian Duffy, Brendan Heery, Ivan Maguire, Charles Nwankire,
Jens Ducreé, Fiona Regan

Contents

- Background information
- Centrifugal microfluidics
- Analytical method on disc
- Detection system
- Integrated system

Phosphorus in water

- Growth limiting nutrient:
 - algal bloom
 - hypoxic waters
 - death of aquatic animals
 - toxic blooms



http://sites.duke.edu/biology217_01_s2011_mkg14/ecological-impacts/eutrophication/



<http://www.natureworldnews.com/articles/15693/20150717/toxic-algae-expected-lake-erie-potentially-worst.htm>



<http://serc.carleton.edu/microbelife/topics/redtide/general.htm>

Traditional analysis

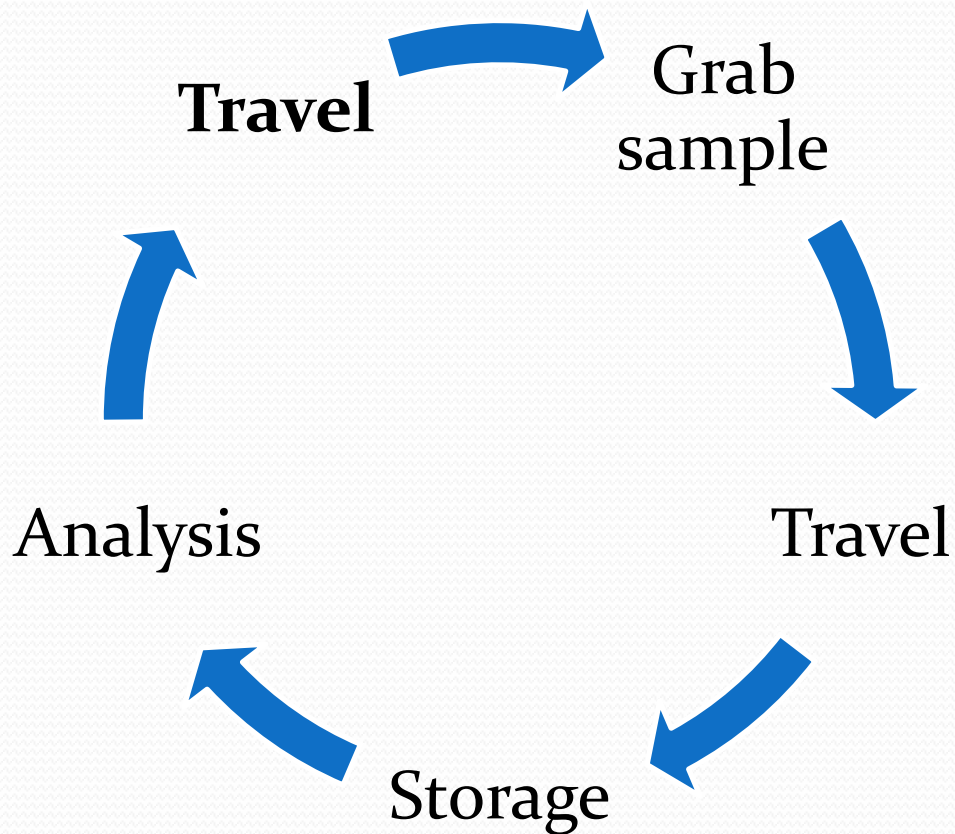

- Time intensive
- Labour intensive
- Expensive instrumentation
- Low sampling frequency
- Contamination

Centrifugal microfluidics

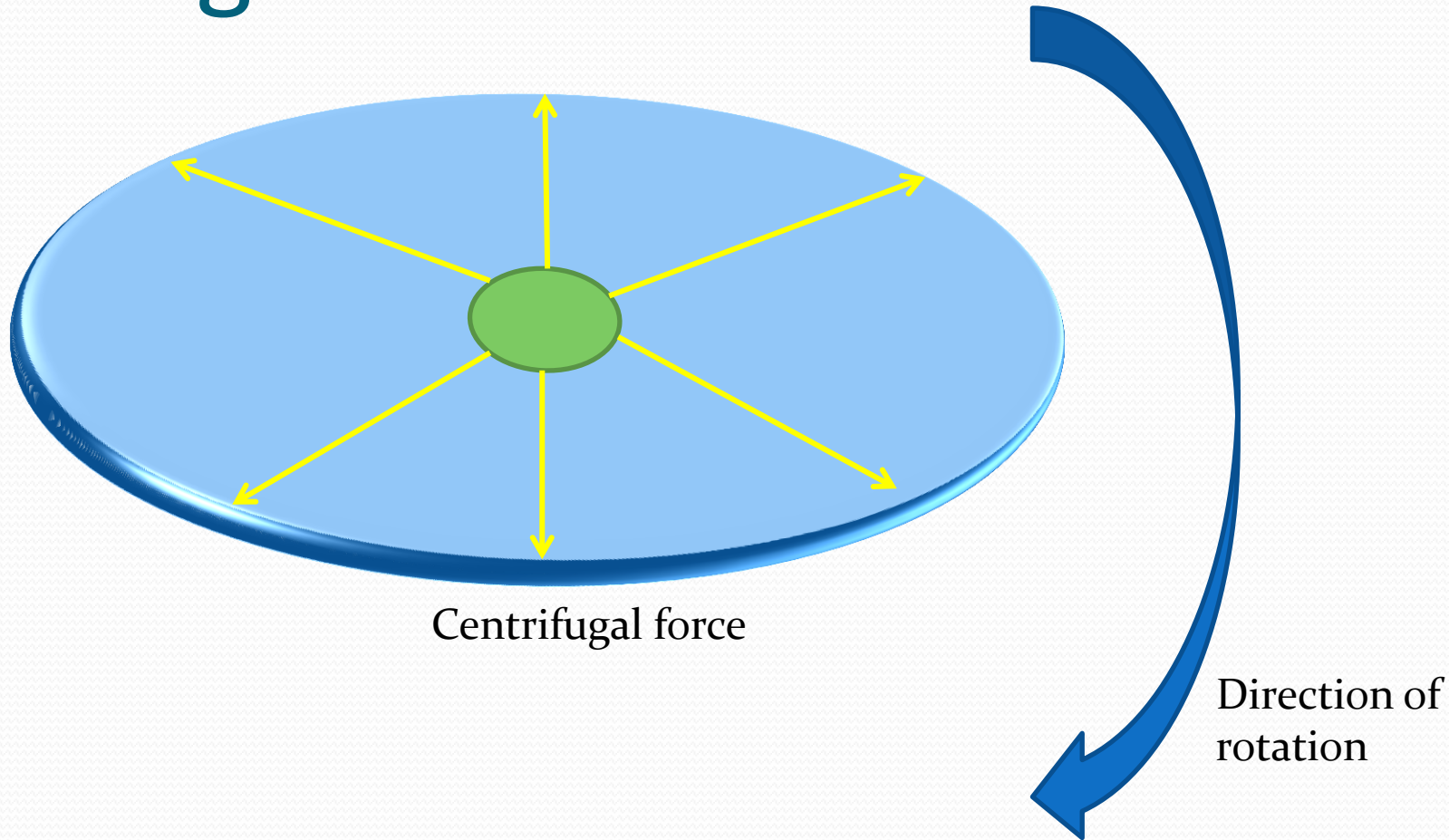

Analytical method

- **Four methods:**
 - High sensitivity
 - Selectivity
 - Simplicity
 - LOD and LOQ
 - Linear range

Analytical method

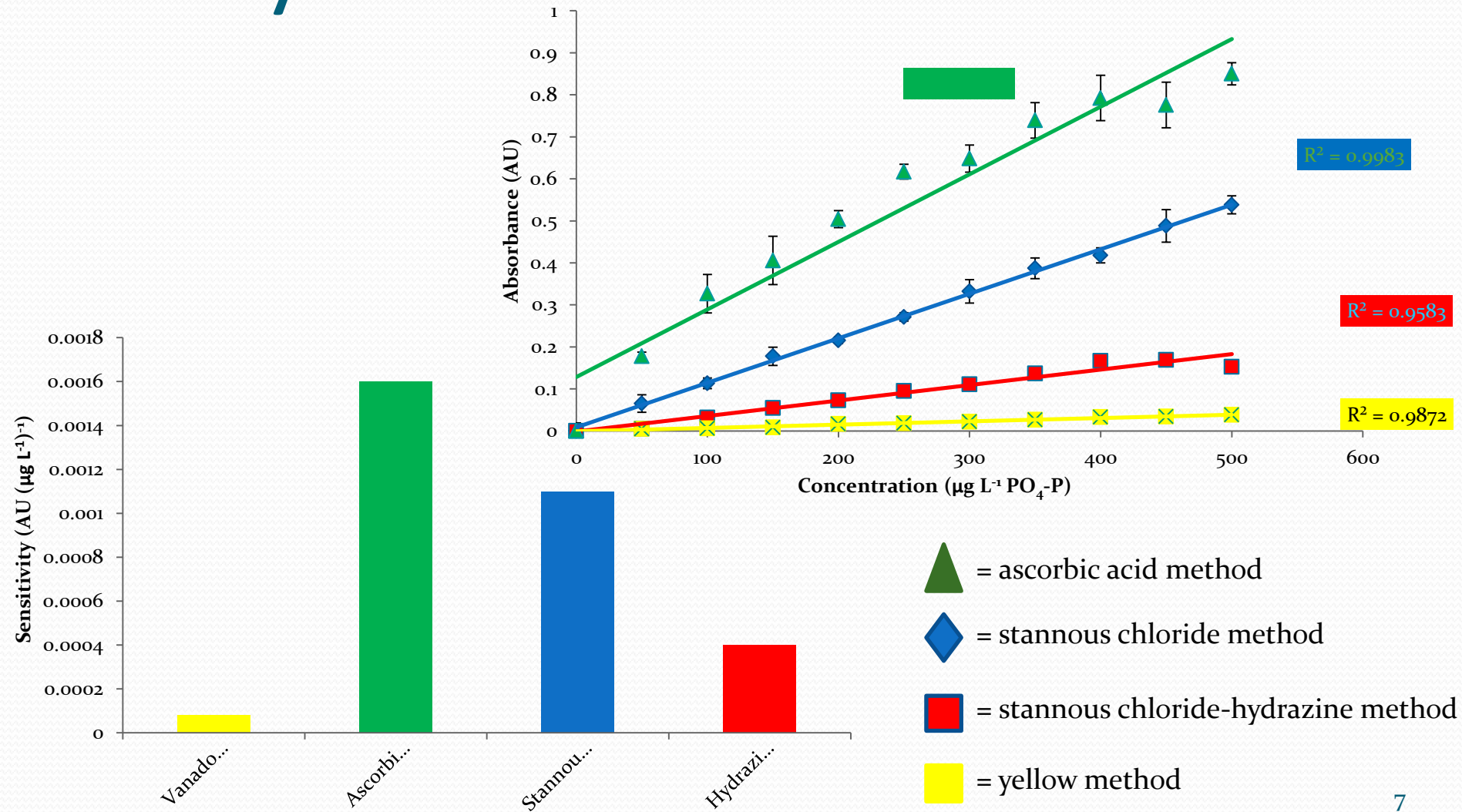

Analytical method

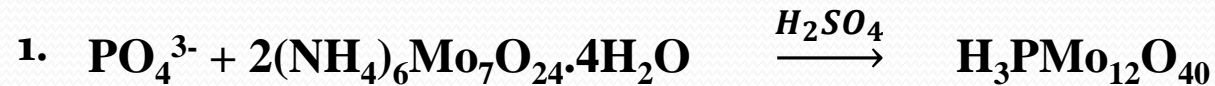
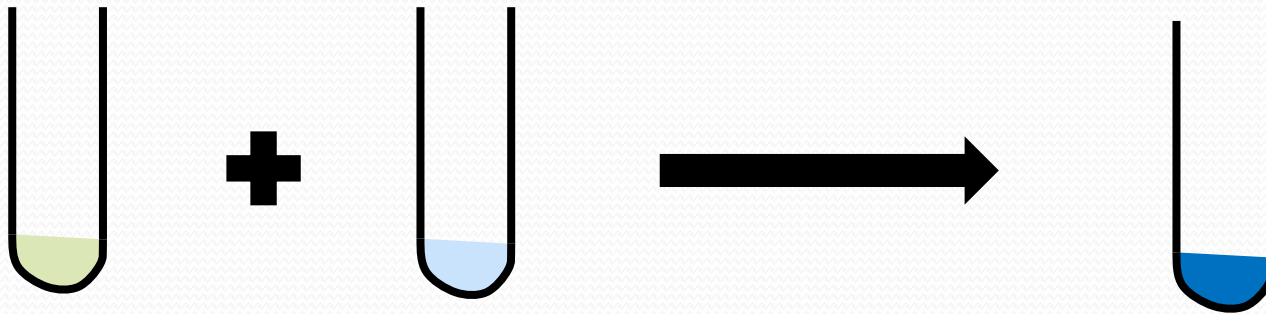

Detection system

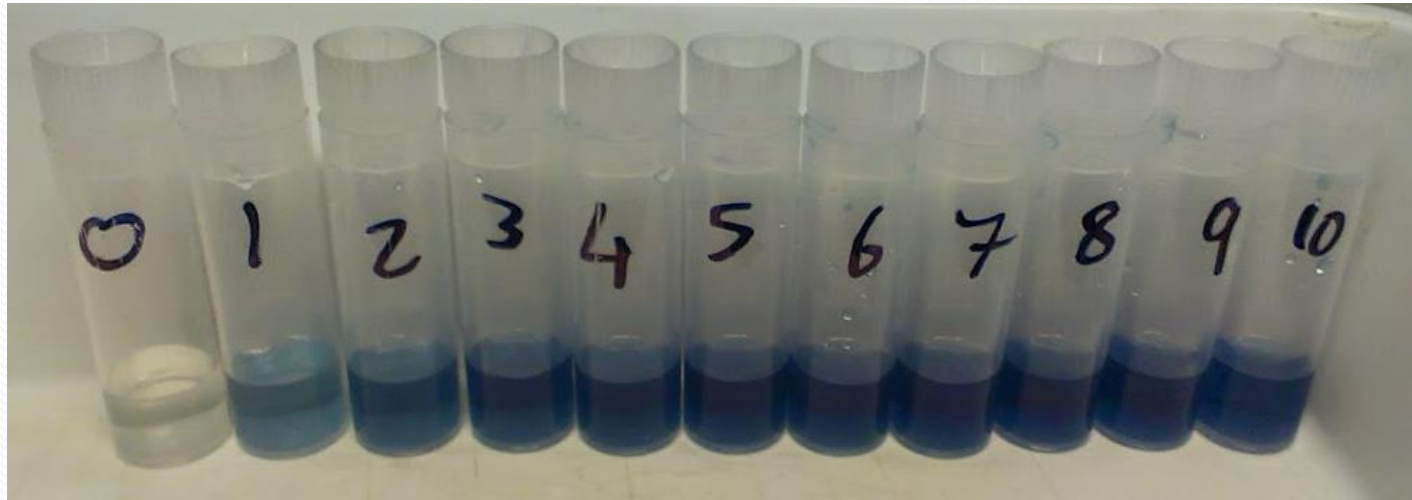

$$A = \epsilon C l \uparrow \text{increase}$$

Microfluidic disc

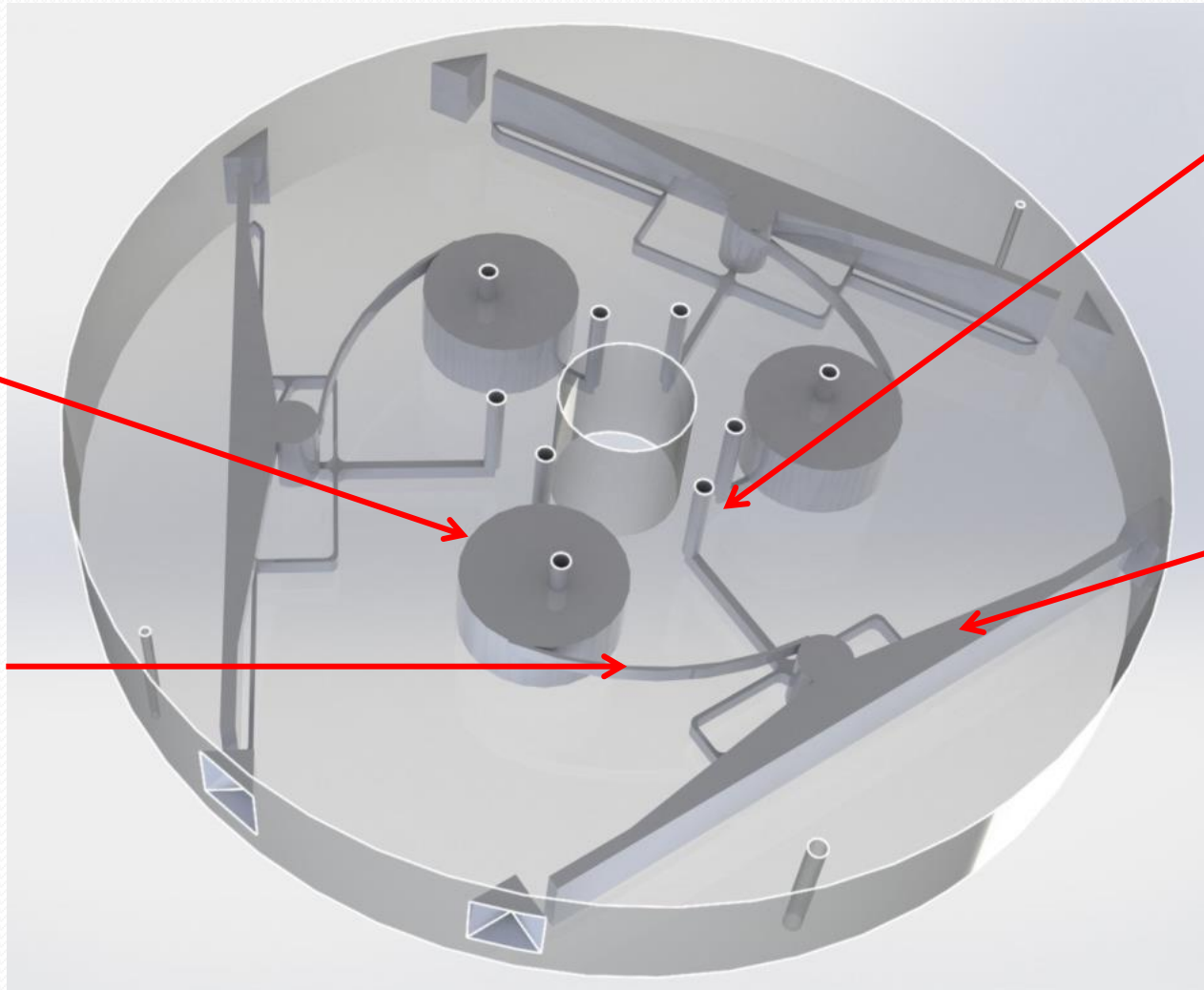

Reservoir

Air vent

Detection chamber

Microchannel

Detection system



Roithner 880 nm laser



Radionics 880 nm LED



Radionics photodiode

Optical path length study

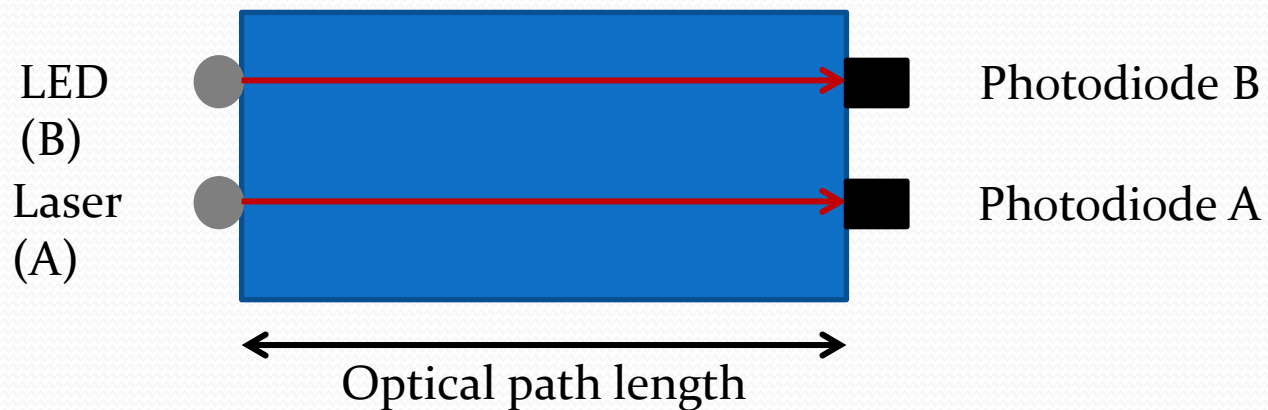
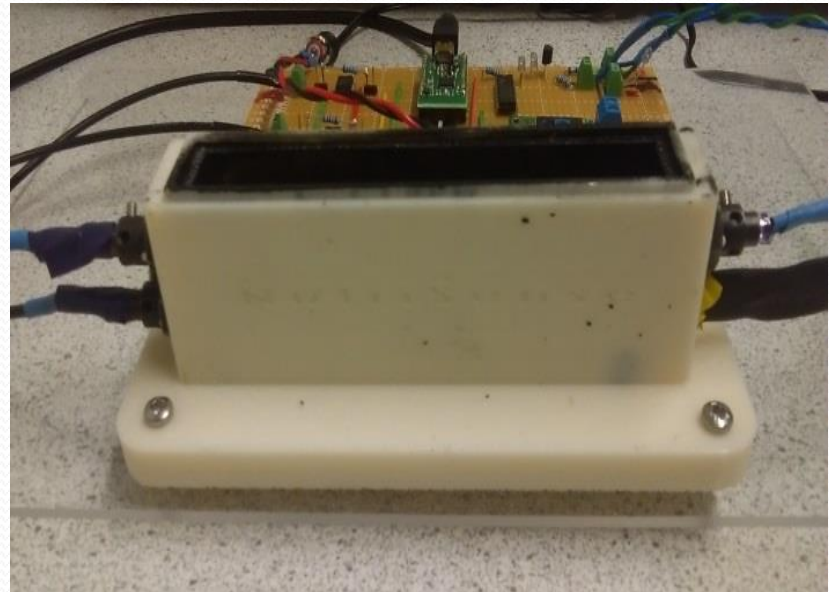
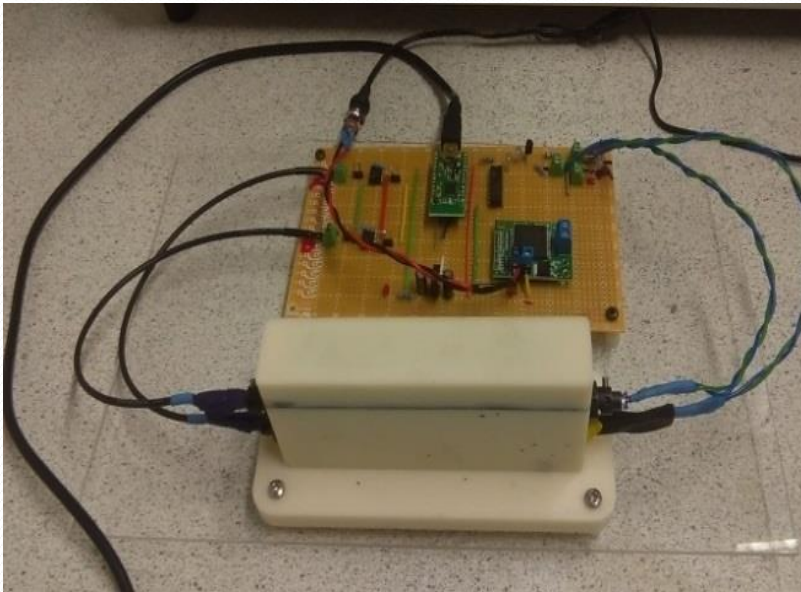

Optical path length study

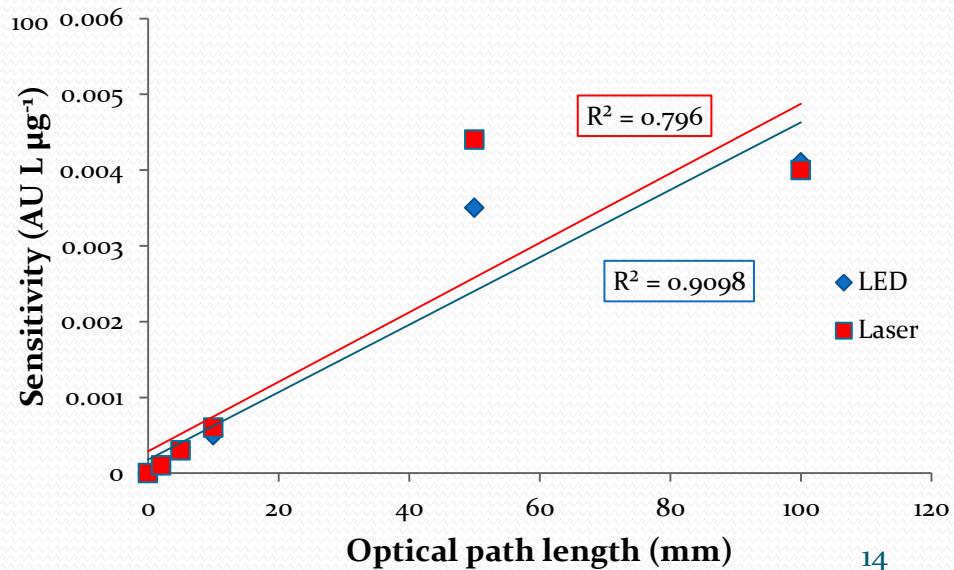
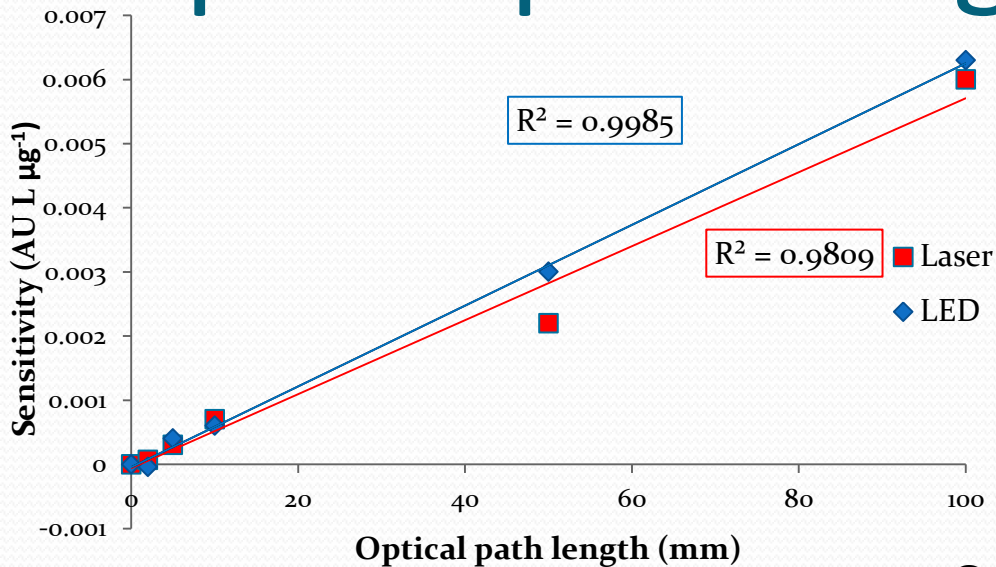

Integrated NutriSense system



Black 3D printed container

Motor to be incorporated for disc rotation

Optical detection system is aligned on the stage

Electronics stored beneath, away from wet chemistry

Conclusion

- Analytical method
- Disc design optimised
 - Mixing
 - bubble formation
 - Optical path length
- Integrated system designed – first prototype fabricated

Future work

- Incorporate motor into system
- Investigate system robustness *in situ*
- Adapt disc design for other analytes for water quality analysis

Acknowledgements

- Brendan Heery
- Ivan Maguire
- Prof. Fiona Regan



Water
Institute





Thank you!