

Brain-wide mapping and digital atlas of projections from rat barrel cortex



A dissertation submitted
to the University of Oslo
for the degree of
Philosophiae Doctor (Ph.D)
February 2015

by
Izabela Maria Żakiewicz
Department of Anatomy
Institute of Basic Medical Sciences
University of Oslo

© **Izabela Maria Żakiewicz, 2015**

*Series of dissertations submitted to the
Faculty of Medicine, University of Oslo
No. 2054*

ISBN 978-82-8333-045-8

All rights reserved. No part of this publication may be reproduced or transmitted, in any form or by any means, without permission.

Cover: Hanne Baadsgaard Utigard.
Printed in Norway: AIT Oslo AS.

Produced in co-operation with Akademika Publishing.
The thesis is produced by Akademika Publishing merely in connection with the thesis defence. Kindly direct all inquiries regarding the thesis to the copyright holder or the unit which grants the doctorate.

TABLE OF CONTENTS

Publications	iv
Acknowledgements	v
Synopsis	
INTRODUCTION	3
Goals of the project	7
Methods	8
Experimental methods	8
Axonal tracers	8
Experimental inclusion criteria	8
Section sampling and histology	9
Image acquisition	9
Online atlas application	9
3D reconstruction	10
3D delineation of axonal labeling	11
Analyses	11
Presence and amount of labeling	11
Comparison with legacy data	12
3D analysis of spatial distribution patterns	12
Results	13
Article I	13
Article II	14
Manuscript	15
Summary of findings	16
Discussion	19
Large-scale mapping studies and data sharing	19
Validity of methods	20
Axonal tracers	20
Histological analyses	21
Reference atlas and nomenclature	22
Workflow and experimental material	23
Functional considerations	23
Conclusions	24
References	25
Articles I – III	35

PUBLICATIONS

Paper I

Workflow and atlas system for brain-wide mapping of axonal connectivity in rat

Zakiewicz IM, van Dongen YC, Leergaard TB and Bjaalie JG
PLoS ONE 2011 6(8): e22669. doi:10.1371/journal.pone.0022669

Paper II

Brain-wide map of efferent projections from rat barrel cortex

Zakiewicz IM, Bjaalie JG, Leergaard TB
Frontiers in Neuroinformatics 02/2014. Doi:10.3389/fninf.2014.00005

Paper III

Three-dimensional histology volume reconstruction of axonal tract tracing data: exploring topographical organization in subcortical projections from rat barrel cortex

Zakiewicz IM, Majka P, Wojcik DK, Bjaalie JG, Leergaard TB
Manuscript

ACKNOWLEDGEMENTS

The present work was carried out at the Department of Anatomy, Institute of Basic Medical Sciences, of the University of Oslo.

I would like to thank my supervisors: Jan Bjaalie and Trygve Leergaard for welcoming me into their group in September 2007 and for the opportunity to conduct a PhD project next year. I appreciate the excellent working condition and I am grateful for the time and engagement they dedicated to this project.

I especially thank all the members of Nesys Group for fabulous atmosphere of scientific collaboration and friendship, for our chocolate Fridays' meetings and all scientific and less- scientific discussions we had. My special appreciation goes to Annabjørge for her help with endless histological staining and for sharing her knowledge and experience with me. I am also very grateful to Daniel Wójcik and Piotr Majka who welcomed me to their Neuroinformatics Group in Warsaw in 2012 and made an essential contribution to the third paper.

My very special thanks go to Professor Peter Kierulf who kindly agreed on guiding this project to the successful end.

I am obliged to all my friends for being extremely supportive and for believing in me: Lisa, you were the best "office mate" and become the best friend from the very first day we meet; Jasna, your enthusiasm and love for life and adventure is contagious ☺ you are truly inspiring; Trine, you were excellent skiing teacher and I really miss our climbing sessions at Klatreverket; Joakim, thank you for all the coffee we drank together! Arnold, thank you for your help and support! I am very grateful for your friendship, and will always be there to help if needed. Piotr, our dinner sessions were a great help toward staying sane ☺ Sylwia, thank you for the time spent in Warsaw: for the wine tasting on Fridays' evenings and the horse-riding trips on Saturdays! May and Ana, I thank you for staying in touch as the years passed. It was a great motivation and very appreciated.

My warmest thanks go to my Parents: Bogusława and Krzysztof for their support and for making finalization of this thesis possible.

I dedicate this thesis to my Parents

Izabela Maria Zakiewicz

Oslo, 2015

Synopsis

Introduction

The brain comprises a vast number of neurons that are interconnected by a hugely larger numbers of synapses. The various axonal pathways between neurons form complex circuits that represent the structural substrate for the different functional systems of the brain. A current grand challenge in neuroscience is to achieve an understanding of how the brain integrates information and coordinates its systems at the circuit level (Bohland *et al.* 2009; Leergaard *et al.* 2012). Since the specific input and output connections of a given brain region determine how various groups of cells may influence each other, knowledge about such connections is important to understand the contribution of different regions to brain function, and to interpret effects of brain damage or disease (Albin *et al.* 1989; Alexander and Crutcher 1990; Bohland *et al.* 2009; Houk and Wise 1995; Tekin and Cummings 2002).

The connections of the brain can be described at different scales: at a macroscopic scale relating to the major pathways and fiber bundle trajectories (Craddock *et al.* 2013), and at a microscopic scale relating to local, cellular level microcircuits and descriptions of specific synaptic contacts and signaling properties (Feldmeyer *et al.* 2013; Henry Markram 2010). However, at a mesoscopic scale, relating to brain systems, the presence of axonal connections are typically registered in wiring diagrams or tables showing regions targeted by axonal projections from a given source region (Bosman *et al.* 2011; Welker *et al.* 1988), and various aspects of spatial organization, topographical arrangement, and mapping of functional properties can be described (Alloway *et al.* 1999; Brown *et al.* 1998; Leergaard *et al.* 2000b).

Following injection of plant lectins or other macromolecules into a brain region, these substances are taken up locally by neurons and anterogradely or retrogradely transported, labeling the entire neural extensions, following which they can be visualized in histological sections (Kobbert *et al.* 2000; Reiner *et al.* 2000; Vercelli *et al.* 2000). A range of different tracers is currently available for visualization of the connections of individual neurons (monosynaptic tracers), and novel tracers now also allow trans-synaptic tracing and visualization of multiple links in a neuronal network (Ohara *et al.* 2009). Experimental tract tracing studies in animals thus allow specific visualization and mapping of connections. Since experimental work is easier in rodents, compared to cats and primates, and rat brain is sufficiently complex to yield relevant data, the rat has so far been the most popular mammalian model for studies of brain systems (Braidly *et al.* 2015; Emborg

2004; Hovda *et al.* 1995; Manger *et al.* 2008; Peterson *et al.* 1994). The characteristic somatotopic distribution of body surface representations in the primary somatosensory cortex (S1), and in particular the grid-like arrangement of mystacial representations in the whisker barrel field of S1 (Chapin and Lin 1984; Dawson and Killackey 1987; Fabri and Burton 1991a; Welker *et al.* 1988) has made the rat barrel cortex a common model for experimental investigations of sensory processing and brain plasticity. For several decades, experimental investigations have been performed to characterize various elements of this system, and specific connections and topographical patterns of organization have been described at many levels (Alloway *et al.* 1999; Chapin and Lin 1984; Dawson and Killackey 1987; Welker *et al.* 1988).

However, despite considerable efforts invested in experimental investigations of axonal connections in the rat somatosensory system over the last decades, it has remained difficult to determine complete wiring diagrams covering the entire brain, and to compare organization of connections across systems (Bohland *et al.* 2009). The lack of complete and integrated descriptions of neural connections may be ascribed to the following two challenges:

- 1) Since experimental studies of rat brain connectivity are typically restricted to one or at most a few regions, it is difficult to retrieve overviews of brain connectivity at the level of brain systems and compare organizing principles across regions.
- 2) Since conventional publications only convey limited amounts of information selected from experimental materials, and presented data formats (drawings, images) usually lack the positional information necessary for comparison, data are difficult to compare across studies, and therefore less suitable for re-interpretation and re-investigation.

Earlier attempts at gaining overview of the efferent connections of S1 in rodents include literature reviews (Bosman *et al.* 2011), and systematic accumulation of published data in database systems (Bakker *et al.* 2012; Bota *et al.* 2005; Bota *et al.* 2012; Kotter 2004; Schmitt and Eipert 2012). But, while these efforts provide extensive overview of earlier reported findings, they do not overcome the problem of the limited scope and limited data presented in these publications. Thus, based on systematic study of the literature it is possible to infer what the main projection of S1 are, but it remains uncertain whether *all* projections have been identified, and it remains difficult to compare the amount and specific organization across different projection targets. This can only be resolved by analyzing axonal projections across the entire brain in the same experimental material (Bohland *et*

al. 2009), such as earlier performed in a milestone analysis of the efferent projections from S1 in the mouse brain (Welker *et al.* 1988). Earlier approaches to accumulate tract-tracing data for comparison of the spatial organization of connections across experiments include use of simplified data representations, such as standardized diagrams (Brodal and Brodal 1981) or 3D reconstructions (Bjaalie *et al.* 2005; Leergaard *et al.* 2000a). While these approaches have allowed efficient comparisons of findings across series of experiments, they are limited by having a narrow scope and by using simplified data representations that are less well suited for data mining purposes.

With the introduction of improved technologies for acquiring, viewing and sharing high-resolution histological section images via the internet (Mikula *et al.* 2007), it has become possible to develop specific digital atlas systems which provide access to organized collections of image data (Boy *et al.* 2006; Holmseth *et al.* 2009; Odeh *et al.* 2011; Zakiewicz *et al.* 2011), via an online portal (www.rbwb.org). Such improved methods for acquisition and web-based sharing of histological images provide a solution for conducting systematic brain-wide analysis of neural connections, but further work is needed to first establish experimental workflows and database infrastructure suitable for such studies, and secondly to provide proof of concept evidence of how brain-wide analyses of axonal connections can provide solutions to the challenges stated above. In a proposal advocating systematic, brain-wide experimental mapping of neural circuits by use of axonal tracers, Bohland and co-authors (Bohland *et al.* 2009) formulated a set of recommendations for how coordinated efforts for investigating neural connections should be conducted, emphasizing that:

- 1) Connectivity studies should have brain-wide coverage,
- 2) Experimental techniques are suitable for standardization and automation, and
- 3) Data collections should be made available in open access repositories suitable for re-use by the community.

Goals of the Project

To contribute to the general ambition of advancing our understanding of how neural systems are connected and organized, the overall goal of the present project has been to pilot new approaches for mapping neural connections in rodent brains more efficiently, by utilizing new virtual microscopy technologies (Mikula *et al.* 2007) and database infrastructures (Bjaalie *et al.* 2005; Boy *et al.* 2006) to conduct a brain-wide mapping study of axonal projections originating from the rat barrel cortex. Adhering to the recommendations proposed by Bohland *et al.* (Bohland *et al.* 2009), we thus set out to:

- 1) Generate new experimental data suitable for mapping axonal connections and comparison of organizing principles across the entire brain
- 2) Make these data available to the community for reanalysis and reinterpretation
- 3) Provide proof of principle evidence that the approach chosen is indeed suitable for conducting brain-wide mapping of axonal connections, and for comparing three-dimensional spatial organization of axonal connections across regions.

In the first project (Zakiewicz *et al.* 2011)(Paper I), we address specific methodological challenges by developing and implementing a workflow for data production and developing an online database system tailored for online presentation of axonal tracing data. In the next two projects we utilize this connectivity atlas system to firstly conduct a brain-wide analysis of the efferent connections of the rat S1 (Zakiewicz *et al.* 2014)(Paper II), and secondly to explore principles of topographical organization of S1 corticostriatal and corticothalamic projections in 3-D reconstructed histology volumes (Zakiewicz *et al.*, manuscript, Paper III). We also compare our approach and results with published legacy data (Bosman *et al.* 2011; Bota *et al.* 2005; Bota *et al.* 2012; Welker *et al.* 1988), and parallel efforts conducted in mice (Oh *et al.* 2014).

Methods

Our ambition was to design an experimental workflow suitable for investigation of various aspects of S1 efferent connections at the whole brain level, and produce an organized collection of histological data suitable for web-based data sharing. The methods implemented in this project were therefore selected to be reproducible and suitable for connectivity studies of any brain system, in line with recommendations for brain-wide investigations of mesoscale connectivity (Bohland *et al.* 2009). All the raw data from our experiments are shared and accessible for reevaluation and reuse.

EXPERIMENTAL METHODS

Axonal tracers

To study the efferent connections of S1 we opted for well-established and extensively used classical axonal tract-tracing techniques that provide specific labeling of the entire axonal projections of interest in histological sections (Lanciego and Wouterlood 2000; Lanciego and Wouterlood 2011; Vercelli *et al.* 2000). To study direct (first degree) connections of S1, we needed anterograde tracers specifically labeling only axons and their collaterals without passing the synaptic cleft. We chose to use two of the most popular and validated tracers that both meet our criteria: biotinylated dextran amines (BDA) (Lazarov 2013; Reiner *et al.* 2000), and *Phaseolus vulgaris* - leucoagglutinin (PHA-L) (Gerfen and Sawchenko 1984). Both tracers are known to have sensitive and specific anterograde labeling properties (Kobbert *et al.* 2000; Lanciego and Wouterlood 2000; Lanciego and Wouterlood 2011; Reiner *et al.* 2000; Veenman *et al.* 1992). BDA (10 kDa) is described as a versatile and robust tracer, but can also give rise to retrograde labeling, as well as secondary anterograde labeling of collateral fibers (Malmierca *et al.* 1998; Merchan *et al.* 1994; Reiner *et al.* 2000). Our additional use of PHA-L, which is known to be purely anterograde tracer (Gerfen and Sawchenko 1984; Vercelli *et al.* 2000) allows differentiation between direct anterograde and possible retrograde or indirect labeling. For anterograde tracing, BDA was delivered by pressure injection, while PHA-L was delivered by iontophoresis as described in Paper I.

Experimental inclusion criteria

Axonal tracer injections were targeted to the forelimb and whisker representations of S1 using stereotaxic coordinates derived from a standard atlas (Paxinos and

Watson 2007). The injections were systematically made at several cortical depths, aiming to cover all cortical layers and achieve comparable injection sites similar in size. As an initial screening, a limited number of sections were sampled from the injected region and processed to visualize labeling (see below). The injection sites were evaluated, and cases fulfilling the following inclusion criteria were selected for further processing and brain-wide investigation:

- 1) The injection site boundaries should be sharp and easy to define
- 2) The tracer should be more or less equally distributed through all cortical layers with overall columnar shape of the injection
- 3) The injection should not extend into the external capsule
- 4) The axonal transport should be visible, especially via the external capsule close to the injection site
- 5) The tissue surrounding the injection site should not be visibly damaged.

Section sampling and histology

Brains were cut in coronal sections of 50 μm thickness, and complete series of sections were sampled. Every second section was processed to visualize BDA or PHA-L, as detailed in Paper I. Counterstaining methods were chosen to give homogeneous background staining facilitating evaluation of anatomical boundaries, while having minimal interference with the black (BDA) or brown (PHA-L) labeling. Sections with BDA labeled fibers were thus counterstained with Neutral Red; and sections with PHA-L labeled fibers were counterstained with Thionine. In addition, alternating sections through the S1 cortex were stained for cytochrome oxidase (CO) to reveal barrel organization in S1 (Wong-Riley 1979). This material was later used to further confirm the localization of injection sites.

Image acquisition

Digital high-resolution mosaic images of entire sections were captured through a 10x objective using a motorized Olympus BX52 light microscope running the Virtual Slice module of NeuroLucida 7.0. Serial images of the histological material from six axonal tract tracing experiments were organized in a database system (Moene *et al.* 2007; Zakiewicz *et al.* 2011) and published online via the Rodent Brain Workbench (www.rbwb.org).

ONLINE ATLAS APPLICATION

The web-based atlas was established to allow efficient browsing and detailed brain-wide examination of axonal labeling. The images were therefore spatially organized

according to serial order and section thickness, and stereotaxic coordinates were assigned by anchoring selected images to a standard atlas template (Paxinos and Watson 2007) on the basis of multiple anatomical landmarks and examination of cyto- and chemo-architectonic features. Anteroposterior positions were then estimated for the remaining images by interpolation. The web-application thus allows sharing of histological images and analysis of connectivity data through virtual microscopy viewers permitting dynamic inspection of sections. Each section is available for viewing in full resolution due to the Zoomify pyramidal file format which only retrieves and displays fragment of an image at screen resolution. The web-application also gives access to metadata describing detailed experimental parameters and a summary of the methods. Detailed experimental procedures are provided in Paper I. The web-atlas was tailored for efficient image browsing and inspection of axonal labeling across entire brains (Paper II).

3D reconstruction

Analyses of complex topographical organization patterns are greatly facilitated by use of 3-D reconstructions (Blackstad *et al.* 1984; Leergaard *et al.* 2000b; Mailly *et al.* 2013; Malmierca *et al.* 1998; Nikundiwe *et al.* 1994). Such reconstructions are typically based on largely manual registration of points representing axonal labeling. While such reconstructions are manageable for smaller brain regions, they are not practically feasible for entire brains. To explore principles of spatial organization of connections in our material, we employed new methods to reconstruct high-resolution images of histological sections into volumetric images (Paper III).

Briefly, series of images from four BDA tract-tracing experiments were downloaded from the web-atlas, reconstructed into volumetric form and then mapped into a common reference space of rat brain atlas (Paxinos and Watson 2007). We used ITK-SNAP software (Yushkevich *et al.* 2006) (<http://www.itksnap.org/>) to handle the data and visualize the final reconstruction. In order to relate the experimental data to the atlas reference, each section image was assigned to the most similar atlas plate. Then, masked images were created using 3D Brain Atlas Reconstructor - a digital atlas tool (Majka *et al.* 2012) (<http://3dbr.org>, 3dBAR). The reconstruction was performed using a simplified approach by (Yushkevich 2006). The coarse registration step relied on aligning masks of the sections to masks of the corresponding atlas plates. Before the alignment, the masks were edited so only reliable and spatially consistent fragments of both, stained sections and corresponding atlas plates, were preserved. The preserved regions were mostly: striatum, brainstem, thalamus and pons. Alignment was done for each coronal block independently. During the fine

alignment step only the slices images were used. Similarly to the coarse step the masks of the slices were modified, therefore spatial correspondence between consecutive slices was preserved. The slices were then aligned sequentially, starting from the middle of each cutting block for each specimen towards either end. Both series of transformations were then combined. Since each slice has a bregma coordinate assigned and it is aligned to a particular atlas plate, it was possible to map the individual reconstructions into the common reference volume of Paxinos and Watson rat brain atlas (Paxinos and Watson 2007) reconstructed with 3dBAR.

3-D delineation of axonal labeling

Image pixels with dark BDA fibers were separated from the Neutral Red stained background with the use of Adobe Photoshop CS5 (Adobe Systems Inc. San Jose, CA, USA). From the original 3-D reconstructed RGB color images two channels were chosen for further processing: the best representation of BDA fibers and the best representation of the background. In other words, the most contrasting channels were selected and processed with calculation and subtract functions from Photoshop. The red background was masked out and the dark BDA fibers were visualized in white color on black background. The results were saved as portable network graphics (png) files in grayscale mode. These binary images were then visualized in 3-D using ITK-SNAP and labeled clusters in the striatum and thalamus was manually delineated and rendered as geometric surface models.

ANALYSES

Having first established a workflow for data production and a brain-wide structured web-based atlas of histological images tailored for online presentation of axonal tract tracing data (Paper I), we secondly utilized this data collection to perform a brain-wide analysis of the presence and amount of axonal labeling in the entire material. Finally, to investigate topographical distribution patterns we utilized the 3-D reconstructed histological image volumes.

Presence and amount of labeling

To map the presence and amount of labeling across the entire brain, an initial screening was performed using the online viewer tool to record the presence of labeling. The spatial location of the labeling was determined by comparison with a rat brain reference atlas (Leergaard *et al.* 2000b; Paxinos and Watson 2007). For selected regions this was facilitated by superimposing atlas diagrams on the section images using affine transformations. The amount of labeled fibers in each

anatomical (sub) region was semi-quantitatively assessed by a single examiner, scoring the observed labeling using a density rating system. The labeling was scored as “weak” for a few labeled fibers that were possible to count, as “moderate” for several fibers that could be distinguished but not counted, and as “strong” for many labeled fibers forming dense plexuses where individual fibers could not be recognized.

Comparison with legacy data

The list of observed projections (labeling patterns) was compared against the available published data about S1 projections (Alloway *et al.* 1999; Bosman *et al.* 2011; Welker *et al.* 1988; Zakiewicz *et al.* 2014) and against data registered in the BAMS2 system (Bota *et al.* 2005), (<http://brancusi1.usc.edu/>). Strengths indicated for connections in BAMS2 were reinterpreted to match that of the present study, aided by the collator notes registered in BAMS2, and cross-check with original references.

3D analysis of spatial distribution patterns

Topographical organization and spatial relations among axonal plexuses in the striatum and thalamus and pons were explored by simultaneous inspection of the four spatially co-registered 3-D reconstructed images volumes in three-plane viewers using ITK-SNAP. In this analysis, we first utilized the volumetric images to assess the 3-D shape of axonal plexuses in the two regions of interest, and secondly to dynamically examine the co-registered geometric surface models. The observed spatial distribution patterns were compared to earlier descriptions of topographical organization in S1 subcortical pathways and maturational gradients that are thought to contribute blueprinting topographical organization at early developmental stages.

Results

PAPER I

OPEN ACCESS Freely available online



Workflow and Atlas System for Brain-Wide Mapping of Axonal Connectivity in Rat

Izabela M. Zakiewicz, Yvette C. van Dongen, Trygve B. Leergaard, Jan G. Bjaalie*

Centre for Molecular Biology and Neuroscience, Institute of Basic Medical Sciences, University of Oslo, Oslo, Norway

More efficient ways of mapping, analyzing, and sharing histological connectivity data are needed. The aim of this project was therefore to create and launch a public online web-application providing high-resolution histological material suitable for investigating brain-wide studies of connectivity at a mesoscopic scale. Our ambition was to establish a data production workflow and create an online web-atlas suitable sharing histological connectivity data for re-use (data mining) by other investigators.

We implemented a workflow for data production and developed an atlas system for online presentation of histological data from axonal tracing experiments. The workflow was established to standardize experimental procedures and to collect metadata for further reference. We conducted series of axonal-tract tracing experiments according to the proposed workflow to obtain the histological material at the whole brain level. We launched a freely available online database system for storing raw histological data.

In this publication we presented:

- A workflow for standardized brain-wide mapping of connections
- An online image repository containing high-resolution images of histological data from six connectivity experiments
- A formalized overview of experimental metadata, and specific metadata description for each experiment
- Proof of concept analysis of collected material concerning the presence of labeling, density of labeling and topographical distribution of labeling.



Brain-wide map of efferent projections from rat barrel cortex

Izabela M. Zakiewicz, Jan G. Bjaalie and Trygve B. Leergaard*

Department of Anatomy, Institute of Basic Medical Sciences, University of Oslo, Oslo, Norway

Having established a web-based atlas holding tract tracing image data, our next aim was to create complete map of axonal projections from different body representations of S1 based on the histological material collected in this database. We thus conducted a data mining project and utilized our online atlas resource to provide the first complete brain-wide map the efferent projections of the S1 barrel cortex, and analyzed the complete selection of images to determine the presence and amount of projections across the entire brain. This overview was compared with available legacy data in rats and mice.

We thus investigated and compared the intracortical and subcortical projections of S1 forelimb and whisker representations, and compared our results to available literature and reports collected in the Brain Architecture Management System (BAMS₂)(Bota *et al.* 2005).

In this publication we presented:

- A brain-wide analysis of S1 efferent connectivity from whisker and forelimb representations with description of general features of labeling, cortico-cortical projections and subcortical projections
- Semi quantitative assessment of all observed connections, presented in tabular form
- Confirmation that projections were absent from brain regions not listed in our table
- A Comparison of projections from S1 whisker and forelimb body representations concerning the presence of projection and general features of labeling such as topography and density
- A Comparison of our findings with available legacy data from earlier overview generated for the mouse brain (Bosman *et al.* 2011; Welker *et al.* 1988), and literature data collected in BAMS₂ database
- A Wiring diagram summarizing finding about connectivity of S1 whisker and forelimb efferent projections.

PAPER III

Three-dimensional histology volume reconstruction of axonal tract tracing data: exploring topographical organization in subcortical projections from rat barrel cortex

Zakiewicz IM^{1,2}, Majka P², Wojcik DK², Bjaalie JG¹, Leergaard TB¹

¹. Institute of Basic Medical Sciences, University of Oslo, Oslo, Norway

². Department of Neurophysiology, Nencki Institute of Experimental Biology, Warsaw, Poland

Arrangement of axonal projections is an anatomical substrate for function. We sought to clarify, with the use of whole brain histological data, how principles of organization of axonal projection vary across different regions. We especially wanted to focus on comparison of the spatial distribution, overlap, and neighboring relationships of whisker and forelimb related projections across the three brain regions: striatum, thalamus and pons. Advantages of 3-D atlas-based analyses of neural connectivity data were employed as series of images from four tract tracing experiments were 3-D reconstructed and combined in a common spatial 3-D atlas template.

We prepared three dimensional reconstructions of axonal plexuses formed within striatum, thalamus and pontine nuclei. The histological data were registered within a common atlas framework based on 3DBarTool (Majka *et al.* 2012). Here we provide a comparison of projection patterns through the brain in one-case studies.

For this project the results are:

- Successful co-registration of complete histological data sets from four tract tracing experiments to each other
- Registration of co-registered histological data sets with a common atlas reference space (Paxinos and Watson 2007)
- 3-D geometric models of axonal plexuses formed within the striatum and thalamus
- Analysis of topographical distribution of axonal plexuses based on the localization of injection site with S1 - within whisker or forelimb representation.

SUMMARY OF FINDINGS

The collection of organized and 3-D reconstructed image allowed us to provide detailed descriptions efferent cortical and subcortical projections from the whisker and forelimb representations in S1. Our two data mining studies (Papers II and III) yielded the following biologically relevant results:

1. We confirmed the presence of most of the projections reported in previous studies. Our results show that S1 whisker and forelimb regions target a range of ipsilateral cortical and subcortical regions, with several contralateral projections of lower density mirroring the location of the ipsilateral projections (graphically summarized in Fig. 1).
2. We reported specific differences between projections arising from S1 whisker and S1 forelimb representations. In general, we found that projections from S1 whisker representation are more extensive than projections from S1 forelimb representations. We thus found that the S1 barrel cortex targeted several cortical (perirhinal, entorhinal, retrosplenial, auditory and visual cortex), and subcortical (red nucleus, claustrum, basolateral amygdaloid nucleus, and submedial thalamic nucleus), that are not projected upon from the S1 forelimb representation.
3. With our brain-wide analysis, we could further report projections that to our knowledge were not emphasized or reported in previous investigations:
 - While projections from S1 whisker representation to the posterior parietal cortex have been reported before (Fabri and Burton 1991b; Koralek *et al.* 1990; Naber *et al.* 2000), our data show that S1 forelimb representations also target this region.
 - We report that S1 projects to the reticular part of substantia nigra. To our knowledge, earlier studies have only reported corticostriatal projections from prefrontal and motor areas (Gerfen *et al.* 1982)
 - While the basal forebrain is known to project to the cerebral cortex (Sripanidkulchai *et al.* 1984), it is less clear if the basal forebrain receives projections from S1. In two cases injected in S1 whisker representations, we observed a few labeled fibers in the anterior part of the basolateral amygdaloid nucleus
 - Further, in the three experiments involving the S1 whisker barrel cortex, we found substantial labeling in the dorsal part of the ipsilateral submedial thalamic nucleus, which in the two cases with the largest injection sites also

included some contralateral labeling. The submedius nucleus is known to receive nociceptive input from the trigeminal nuclei and spinal cord, and has been implicated in modulatory nociceptive processes (Craig, Jr. and Burton 1981; Craig, Jr. *et al.* 1982; Dawson and Killackey 1987). This region is reciprocally connected with the cerebral cortex in cat (Craig, Jr. *et al.* 1982), but these connections have, as far as we can determine, not been emphasized in earlier studies of the rat brain.

4. In contrast to earlier reports, our results indicate that some previously reported S1 projections are relatively insignificant:
 - Somatosensory projections to the red nucleus have been described by use of electrophysiological recordings (Ebrahimi-Gaillard and Roger 1993) and retrograde tracing techniques (Akintunde and Buxton 1992; Bernays *et al.* 1988), but our anterograde tracing results indicate that corticorubral projections from S1 forelimb and whisker representations are minor.
 - In our material, corticotectal projections to the superior colliculus were loosely distributed across several layers, and did not aggregate in distinct, topographically organized clusters as described in several earlier studies (Hoffer *et al.* 2005; Hoffer *et al.* 2003; Schwarz and Thier 1995; Wise and Jones 1977)
 - The modest labeling observed in trigeminal nuclei in our material stands in contrast to the rather rich corticotrigeminal labeling seen after tracer injections into S1 orofacial regions (Tomita *et al.* 2012).

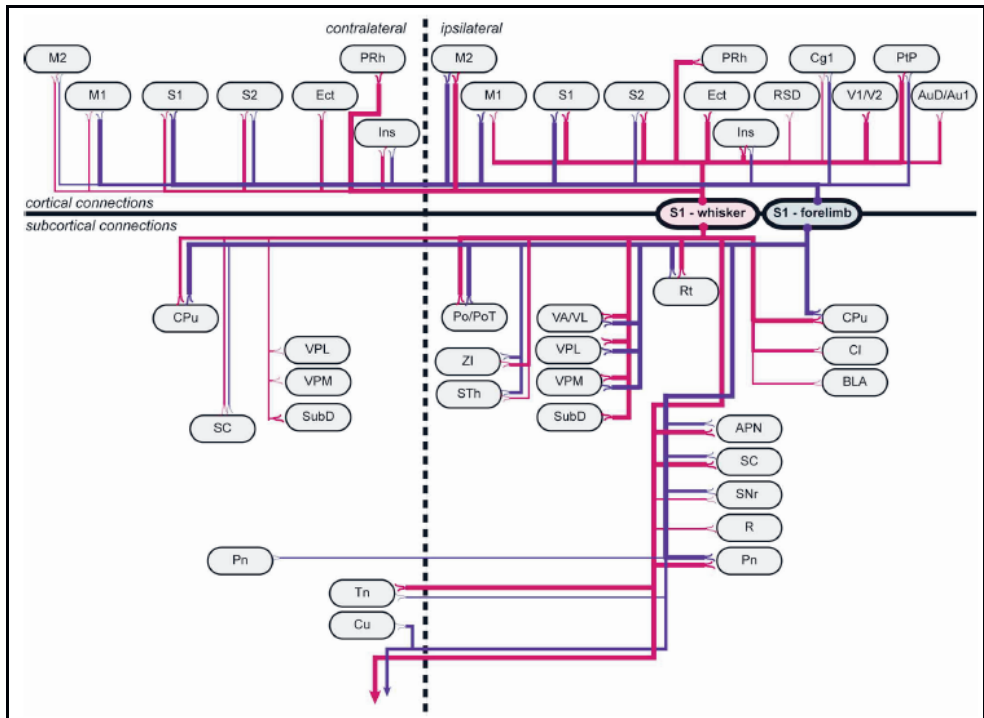

Figure 1. Summary diagram showing all connections observed in experiments. Connections arising from s1 whisker representations are indicated by red lines, and connections arising from s1 forelimb representations are indicated by blue lines. Line thickness corresponds to the amount of labeling (low, medium or high). apn, anterior pretectal nucleus; au1, primary auditory cortex; aud, secondary auditory cortex, dorsal area; bla, basolateral amygdaloid nucleus, anterior part; cg1, cingulate cortex, area 1; cl, claustrum; cpu, caudate putamen (striatum); cu, cuneate nucleus; ect, ectorhinal cortex; ins, insular cortex; m1, primary motor cortex; m2, secondary motor cortex; pn, pontine nuclei; po, posterior thalamic nuclear group; pot, posterior thalamic nuclear group, triangular part; prh, perirhinal cortex; ptp, posterior parietal cortex; r, red nucleus; rsd, retrosplenial cortex; rt, reticular thalamic nucleus; s1, primary somatosensory cortex; s2, secondary somatosensory cortex; sc, superior colliculus; snr, substantia nigra, reticular part; sth, subthalamic nucleus; subd, submedial thalamic nucleus, dorsal part; tn trigeminal nuclei; v1, primary visual cortex; v2, secondary visual cortex; va/vl, ventral anterior and ventrolateral thalamic nucleus; vpl, ventral posterolateral thalamic nucleus; vpm, ventral posteromedial thalamic nucleus; zi, zona incerta. (Reproduced from Paper 1)

Discussion

We have created a workflow for mapping rat brain connectivity at mesoscale across the entire brain. We used this workflow to establish an online atlas application for sharing of histological tract tracing data (Paper I), and we have provided two proof-of-concept analyses exemplifying how systematic brain-wide investigations of neural connections in the rat brain at mesoscopic scale can be conducted by data mining web-based atlas applications (Papers II and III). In this way, we have addressed the two main challenges stated in the Introduction, concerning the limited scope of tract tracing studies, and some of the challenges pertaining to comparison across studies and re-investigation or re-interpretation of published data. This project thus demonstrates how systematic tract tracing studies of rat brain connections can be performed, and exemplifies how shared connectivity image data can be re-used in context of establishing more complete wiring diagrams of brain regions, and exploring principles of topographical organization across regions.

LARGE-SCALE MAPPING STUDIES AND DATA SHARING

The data collection shared via the Rodent Brain Workbench is a novel and so far unique resource for the rat brain. Earlier large scale efforts to gain overview of tract tracing data from the rat brain have been based on accumulation of data collected from published reports (Bota *et al.* 2005; Bota *et al.* 2012; Bota *et al.* 2014; Schmitt and Eipert 2012; van Strien *et al.* 2009). Compared to these resources, the main advantage of our approach is that experiments analyzed at the whole brain level provide more conclusive data concerning the completeness of mapping, regarding presence and absence of connections. In addition, by providing access to raw image data, it also becomes possible to efficiently look up and explore specific aspects of connections in the original data.

In parallel with our work, several conceptually similar large-scale resources have also been developed for the mouse brain, including the Mouse Brain Architecture Project (<http://brainarchitecture.org/>), the Mouse Brain Connectome project (<http://www.mouseconnectome.org/>) (Hintiryan *et al.* 2012; Zingg *et al.* 2014) and the Allen Mouse Brain Connectivity Atlas (<http://connectivity.brain-map.org/>) (Oh *et al.* 2014). These resources all provide access to very large collections of experimental tract-tracing data covering most parts of the mouse

brain. Common for these resources is that they provide online access to raw serial image data from tract tracing studies and allow interactive inspection of tracer injection sites and ensuing labeling patterns in online viewer tools. So far these data repositories have yielded a limited number of studies reporting on the presence of connections for specific brain systems (Paper II) (Hintiryan *et al.* 2012) or more extensive aspects of mouse brain connectivity (Oh *et al.* 2014; Zingg *et al.* 2014).

While our report of S1 efferent projections could be summarized in a classic wiring diagram (Fig. 1), the mouse brain studies had considerably larger coverage of tracer injection locations, and could therefore summarize observations in more complex connectivity matrix diagrams, and further employ computational network analyses to describe brain systems (Zingg *et al.* 2014). On the other hand, at the level of investigating topographical principles of organization, the full potential of the online data collections have not yet been utilized. Oh *et al.*, (2014) (Oh *et al.* 2014) visualized the overall topographical organization of mouse brain corticostriatal and cortiothalamic projections. We demonstrated that co-registered data from different experiments could reproduce fine-graded topographical organization of corticothalamic projections shown earlier by dual anterograde tracing (Paper I), and extended this to demonstrate how 3-D reconstructed image data facilitate investigations of 3-D spatial distribution patterns (Paper III). Together these studies provide examples for how such online resources can be utilized for further brain-wide investigations of topographical organization across the entire mouse brain.

VALIDITY OF METHODS

Axonal tracers

The employed axonal tracing paradigms are well established, and the tracers BDA and Pha-L are both known to have sensitive and specific anterograde labeling properties (Gerfen and Sawchenko 1984; Kobbert *et al.* 2000; Lanciego and Wouterlood 2011; Veenman *et al.* 1992; Vercelli *et al.* 2000). More elaborate paradigms with multiple fluorescent tracers were considered disadvantageous since whole-section image acquisition is more challenging with fluorescent labeling. Such paradigms may, however, be relevant with the use of improved slide scanning systems.

It should be noted that BDA also gives rise to retrograde labeling, as well as secondary anterograde labeling of collateral fibers (Malmierca *et al.* 1998; Merchan *et al.* 1994; Reiner *et al.* 2000). Thus, some of the BDA labeling in our data sets may not represent direct anterograde connections, in contrast to the Pha-L labeling

which is known to be purely anterograde (Gerfen and Sawchenko 1984; Vercelli *et al.* 2000). In our analyses (Paper II), we found corresponding results with both tracers, and thus no evidence of such indirect projections.

Overall, our results were in agreement with earlier reports, allowing us to conclude that the employed experimental paradigm yielded valid results. Some discrepancies with earlier reports concern relatively weak projections, and can be explained by use of different paradigms (e.g. retrograde tracing rather than anterograde tracing), or the specific location and size of tracer injections sites in S1 or the size. The most conspicuous differences concerned our finding of relatively modest projections to the superior colliculus and trigeminal nuclei (Paper II), which contrasts earlier reports (Hoffer *et al.* 2003; Schwarz and Thier 1995; Tomita *et al.* 2012; Wise *et al.* 1979; Wise and Jones 1977). Given the robust labeling found in other brain regions, there is no reason to doubt the efficacy of the tracers employed in our experiments. We surmise that the observed differences may relate to differences in the size of tracer injections. In any case, such variations among studies will be easier to interpret when complete underlying raw image data are shared.

Histological analyses

Our analyses were based on manual inspection of labeling in organized collections of images by use of dynamic viewer tools. In our hands this provided a better overview of the material and allowed more efficient evaluation compared to traditional microscopic inspection. In regions with very weak labeling, presence of labeled fibers was confirmed by conventional microscopy allowing fine focusing to follow labeled fibers through the tissue. Since stereotaxic location was assigned to each section in the atlas repository, we could efficiently related images to relevant diagrams in the anatomical reference atlas employed. For our brain-wide survey of S1 projections (Paper II) we adopted a semi-quantitative approach (modified from (Boy *et al.* 2006) where the amount of labeling was manually scored according to predefined criteria. While this approach was well suited for gaining overview of projections and assessment of relative variations in projection densities between cases, this approach is not suited for use of quantitative methods. We also attempted using automated approaches based on computerized image analysis, but found this to be problematic due to variations in staining intensity and background across the material, and inclusion of passing fibers in the results. With our 3-D reconstructed volumetric images (Paper III), we discovered that dynamic viewing in three-plane viewer tools facilitated detection of the most prominent labeling patterns and comparison across cases.

Reference atlas and nomenclature

For all experimental work and subsequent analyses, we chose to use the widely used stereotaxic reference atlas of Paxinos and Watson to define stereotaxic coordinates, and to assign anatomical boundaries and structure names. When comparing our results with earlier publications, we encountered some challenges related to the use of different nomenclature and boundary definitions. One example concerned the definition of the anterior part of the claustrum, where the employed atlas (Paxinos and Watson 2007) was not updated with respect to more recent structural information (Mathur *et al.* 2009). A related problem was found with our observations of S1 barrel cortex projections to the ectorhinal cortex, which is referred to by different terms (postrhinal cortex) in earlier studies of connections (Burwell *et al.* 1995; Naber *et al.* 2000). An third important problem was illustrated by our re-analysis of tracer injection sites, which was prompted by our finding that the axonal labeling in one cases was differently distributed within several target regions. When we re-visited the analysis of injection site locations and compared the 3-D visualizations of combined injection sites with a composite functional map of the S1 and M1 cortex, it became evident that one of the injection sites was probably located in M1 rather than S1. The stereotaxic coordinates assigned to this injection site were correct, but we discovered that the functional maps of S1 differed between our reference atlas (Paxinos and Watson 2007) and other maps based on electrophysiological mapping (Chapin and Lin 1984; Leergaard *et al.* 2004). These examples illustrate the need for efficient ways to compare and translate between different brain atlases. While it is inevitable that reference atlases will be changed and updated with knowledge, it is of key importance that accurate 3-D anatomical coordinates are assigned, so that spatial location can be used to translate between atlases (Bjaalie 2002).

Our studies have further demonstrated the importance of correct assignment of anatomical location and registration of experimental data to a common spatial reference frame. Information about anteroposterior coordinates (distance from bregma) allows efficient look up in standard brain atlases. This would facilitate recognition of brain structures by external users and would help in reevaluation of the material and findings. Access to new open access volumetric atlas resources for the rat brain (Papp *et al.* 2014), will like open new possibilities integration of section image data in a common reference space. Registration of image data to a common reference space will both benefit brain-wide analyses and comparison across cases (as exemplified in Paper III).

Workflow and experimental material

Interpretation, evaluation and re-use of any set of biological experimental data require access to detailed and relevant metadata describing animals, experimental parameters, and procedures. Since the spatial distribution and amount of axonal labeling is highly dependent on the position and extent of the tracer injection site, detailed documentation of the injection sites is particularly important. We have suggested metadata descriptions, which in our hands were found sufficient for data-mining purposes. The presented workflow consists of multiple steps that can be further optimized. This particularly concerns technically challenging steps pertaining to the morphological quality of the histological material, and achieving homogeneous labeling and background staining intensity across all sections. Moreover, given the advantages gained by access to 3-D reconstructed histological image volumes (reported in Paper III), we deem it worthwhile to invest in use of block face imaging and careful histological processing to create a material optimized for 3-D reconstruction and automated image-analysis. Such investments will likely be compensated by achieving considerably more efficient analyses.

FUNCTIONAL CONSIDERATIONS

Compared to earlier efforts, our brain-wide analysis contributes more complete and detailed information about S1 efferent projections, both regarding completeness and information about differences between projections from the S1 whisker and forelimb cortex. We showed that these generally reach the same targets, but that projections from the S1 barrel cortex target more sensory related cortical areas as well as some additional subcortical brain regions. Similarly, our evaluation of topographical organization also revealed that S1 projections to the thalamus have higher density and more spatial segregation compared to S1 projections to the striatum. This finding is in line with the important role of the whiskers in rodent sensory exploration. Also, tracer injections involving the neighboring M1, revealed considerably stronger projections to the striatum than to the thalamus. This is in line with involvement of the striatum in coordination of executive behavior.

Conclusions

The present project (Papers I-III) and similar large scale parallel projects (Hintiryan *et al.* 2012; Oh *et al.* 2014; Zingg *et al.* 2014) have demonstrated how investigations of mesoscale connectivity in rodent brains can be expanded to have brain-wide coverage, and further how the large data collections from such investigations can be made publicly available and re-used for various analyses. We have specifically demonstrated how our atlas system can be used for determining presence of connections, densities, as well as spatial organization of connections throughout the brain. The data system provided may also well be utilized to organize and share existing collections of tract tracing data. By providing tested workflow and example analyses demonstrating how data collections can be made and utilized, we have hopefully made some steps forward by paving the way for further large scale investigations of connections in the rat brain.

References

1. Akintunde, A. and Buxton, D. F. (1992). Origins and collateralization of corticospinal, corticopontine, corticorubral and corticostriatal tracts: a multiple retrograde fluorescent tracing study. *Brain Res.* **586**, 208-218.
2. Albin, R. L., Young, A. B., and Penney, J. B. (1989). The functional anatomy of basal ganglia disorders. *Trends Neurosci.* **12**, 366-375.
3. Alexander, G. E. and Crutcher, M. D. (1990). Functional architecture of basal ganglia circuits: neural substrates of parallel processing. *Trends Neurosci.* **13**, 266-271.
4. Alloway, K. D., Crist, J., Mutic, J. J., and Roy, S. A. (1999). Corticostriatal projections from rat barrel cortex have an anisotropic organization that correlates with vibrissal whisking behavior. *J.Neurosci.* **19**, 10908-10922.
5. Bakker, A., Krauss, G. L., Albert, M. S., Speck, C. L., Jones, L. R., Stark, C. E., Yassa, M. A., Bassett, S. S., Shelton, A. L., and Gallagher, M. (2012). Reduction of hippocampal hyperactivity improves cognition in amnesic mild cognitive impairment. *Neuron* **74**, 467-474.
6. Bernays, R. L., Heeb, L., Cuenod, M., and Streit, P. (1988). Afferents to the rat red nucleus studied by means of D-[3H]aspartate, [3H]choline and non-selective tracers. *Neuroscience* **26**, 601-619.
7. Bjaalie, J. G. (2002). Opinion: Localization in the brain: new solutions emerging. *Nat.Rev.Neurosci.* **3**, 322-325.
8. Bjaalie, J. G., Leergaard, T. B., Lillehaug, S., Odeh, F., Moene, I. A., Kjode, J. O., and Darin, D. (2005). Database and tools for analysis of topographic organization and map transformations in major projection systems of the brain. *Neuroscience* **136**, 681-695.
9. Blackstad, T. W., Osen, K. K., and Mugnaini, E. (1984). Pyramidal neurones of the dorsal cochlear nucleus: a Golgi and computer reconstruction study in cat. *Neuroscience* **13**, 827-854.
10. Bohland, J. W., Wu, C., Barbas, H., Bokil, H., Bota, M., Breiter, H. C., Cline, H. T., Doyle, J. C., Freed, P. J., Greenspan, R. J., Haber, S. N., Hawrylycz,

- M., Herrera, D. G., Hilgetag, C. C., Huang, Z. J., Jones, A., Jones, E. G., Karten, H. J., Kleinfeld, D., Kotter, R., Lester, H. A., Lin, J. M., Mensh, B. D., Mikula, S., Panksepp, J., Price, J. L., Safdieh, J., Saper, C. B., Schiff, N. D., Schmahmann, J. D., Stillman, B. W., Svoboda, K., Swanson, L. W., Toga, A. W., Van Essen, D. C., Watson, J. D., and Mitra, P. P. (2009). A proposal for a coordinated effort for the determination of brainwide neuroanatomical connectivity in model organisms at a mesoscopic scale. *PLoS.Comput.Biol.* **5**, e1000334.
11. Bosman, L. W., Houweling, A. R., Owens, C. B., Tanke, N., Shevchouk, O. T., Rahmati, N., Teunissen, W. H., Ju, C., Gong, W., Koekkoek, S. K., and De Zeeuw, C. I. (2011). Anatomical pathways involved in generating and sensing rhythmic whisker movements. *Front Integr.Neurosci.* **5**, 53.
 12. Bota, M., Dong, H. W., and Swanson, L. W. (2005). Brain architecture management system. *Neuroinformatics.* **3**, 15-48.
 13. Bota, M., Dong, H. W., and Swanson, L. W. (2012). Combining collation and annotation efforts toward completion of the rat and mouse connectomes in BAMS. *Front Neuroinform.* **6**, 2.
 14. Bota, M., Talpalaru, S., Hintiryan, H., Dong, H. W., and Swanson, L. W. (2014). BAMS2 workspace: a comprehensive and versatile neuroinformatic platform for collating and processing neuroanatomical connections. *J.Comp Neurol.* **522**, 3160-3176.
 15. Boy, J., Leergaard, T. B., Schmidt, T., Odeh, F., Bichelmeier, U., Nuber, S., Holzmann, C., Wree, A., Prusiner, S. B., Bujard, H., Riess, O., and Bjaalie, J. G. (2006). Expression mapping of tetracycline-responsive prion protein promoter: digital atlasing for generating cell-specific disease models. *Neuroimage.* **33**, 449-462.
 16. Braidy, N., Poljak, A., Jayasena, T., Mansour, H., Inestrosa, N. C., and Sachdev, P. (2015). Accelerating Alzheimer's research through 'natural' animal models. *Curr.Opin.Psychiatry.*
 17. Brodal, P. and Brodal, A. (1981). The olivocerebellar projection in the monkey. Experimental studies with the method of retrograde tracing of horseradish peroxidase. *J.Comp Neurol.* **201**, 375-393.

18. Brown, L. L., Smith, D. M., and Goldbloom, L. M. (1998). Organizing principles of cortical integration in the rat neostriatum: corticostriate map of the body surface is an ordered lattice of curved laminae and radial points. *J.Comp Neurol.* **392**, 468-488.
19. Burwell, R. D., Witter, M. P., and Amaral, D. G. (1995). Perirhinal and postrhinal cortices of the rat: a review of the neuroanatomical literature and comparison with findings from the monkey brain. *Hippocampus* **5**, 390-408.
20. Chapin, J. K. and Lin, C. S. (1984). Mapping the body representation in the SI cortex of anesthetized and awake rats. *J.Comp Neurol.* **229**, 199-213.
21. Craddock, R. C., Jbabdi, S., Yan, C. G., Vogelstein, J. T., Castellanos, F. X., Di, Martino A., Kelly, C., Heberlein, K., Colcombe, S., and Milham, M. P. (2013). Imaging human connectomes at the macroscale. *Nat.Methods* **10**, 524-539.
22. Craig, A. D., Jr. and Burton, H. (1981). Spinal and medullary lamina I projection to nucleus submedius in medial thalamus: a possible pain center. *J.Neurophysiol.* **45**, 443-466.
23. Craig, A. D., Jr., Wiegand, S. J., and Price, J. L. (1982). The thalamo-cortical projection of the nucleus submedius in the cat. *J.Comp Neurol.* **206**, 28-48.
24. Dawson, D. R. and Killackey, H. P. (1987). The organization and mutability of the forepaw and hindpaw representations in the somatosensory cortex of the neonatal rat. *J.Comp Neurol.* **256**, 246-256.
25. Ebrahimi-Gaillard, A. and Roger, M. (1993). [The corticorubral projection in rats: topographic distribution of fibers arising from areas of the sensorimotor cortex functionally identified by microstimulation]. *C.R.Acad.Sci.III* **316**, 502-507.
26. Emborg, M. E. (2004). Evaluation of animal models of Parkinson's disease for neuroprotective strategies. *J.Neurosci.Methods* **139**, 121-143.
27. Fabri, M. and Burton, H. (1991a). Ipsilateral cortical connections of primary somatic sensory cortex in rats. *J.Comp Neurol.* **311**, 405-424.
28. Fabri, M. and Burton, H. (1991b). Topography of connections between primary somatosensory cortex and posterior complex in rat: a multiple fluorescent tracer study. *Brain Res.* **538**, 351-357.

29. Feldmeyer, D., Brecht, M., Helmchen, F., Petersen, C. C., Poulet, J. F., Staiger, J. F., Luhmann, H. J., and Schwarz, C. (2013). Barrel cortex function. *Prog.Neurobiol.* **103**, 3-27.
30. Gerfen, C. R., O'Leary, D. D., and Cowan, W. M. (1982). A note on the transneuronal transport of wheat germ agglutinin-conjugated horseradish peroxidase in the avian and rodent visual systems. *Exp.Brain Res.* **48**, 443-448.
31. Gerfen, C. R. and Sawchenko, P. E. (1984). An anterograde neuroanatomical tracing method that shows the detailed morphology of neurons, their axons and terminals: immunohistochemical localization of an axonally transported plant lectin, Phaseolus vulgaris leucoagglutinin (PHA-L). *Brain Res.* **290**, 219-238.
32. Henry Markram (2010). Microcircuitry of The Neocortex. In 'Handbook of Brain Microcircuits'. (Gordon M.Shepherd and Sten GrillnerEds.) (Oxford University Press:
33. Hintiryan, H., Gou, L., Zingg, B., Yamashita, S., Lyden, H. M., Song, M. Y., Grewal, A. K., Zhang, X., Toga, A. W., and Dong, H. W. (2012). Comprehensive connectivity of the mouse main olfactory bulb: analysis and online digital atlas. *Front Neuroanat.* **6**, 30.
34. Hoffer, Z. S., Arantes, H. B., Roth, R. L., and Alloway, K. D. (2005). Functional circuits mediating sensorimotor integration: quantitative comparisons of projections from rodent barrel cortex to primary motor cortex, neostriatum, superior colliculus, and the pons. *J.Comp Neurol.* **488**, 82-100.
35. Hoffer, Z. S., Hoover, J. E., and Alloway, K. D. (2003). Sensorimotor corticocortical projections from rat barrel cortex have an anisotropic organization that facilitates integration of inputs from whiskers in the same row. *J.Comp Neurol.* **466**, 525-544.
36. Holmseth, S., Scott, H. A., Real, K., Lehre, K. P., Leergaard, T. B., Bjaalie, J. G., and Danbolt, N. C. (2009). The concentrations and distributions of three C-terminal variants of the GLT1 (EAAT2; slc1a2) glutamate transporter protein in rat brain tissue suggest differential regulation. *Neuroscience* **162**, 1055-1071.

37. Houk, J. C. and Wise, S. P. (1995). Distributed modular architectures linking basal ganglia, cerebellum, and cerebral cortex: their role in planning and controlling action. *Cereb.Cortex* **5**, 95-110.
38. Hovda, D. A., Lee, S. M., Smith, M. L., Von, Stuck S., Bergsneider, M., Kelly, D., Shalmon, E., Martin, N., Caron, M., Mazziotta, J., and . (1995). The neurochemical and metabolic cascade following brain injury: moving from animal models to man. *J.Neurotrauma* **12**, 903-906.
39. Kobbert, C., Apps, R., Bechmann, I., Lanciego, J. L., Mey, J., and Thanos, S. (2000). Current concepts in neuroanatomical tracing. *Prog.Neurobiol.* **62**, 327-351.
40. Koralek, K. A., Olavarria, J., and Killackey, H. P. (1990). Areal and laminar organization of corticocortical projections in the rat somatosensory cortex. *J.Comp Neurol.* **299**, 133-150.
41. Kotter, R. (2004). Online retrieval, processing, and visualization of primate connectivity data from the CoCoMac database. *Neuroinformatics.* **2**, 127-144.
42. Lanciego, J. L. and Wouterlood, F. G. (2000). Neuroanatomical tract-tracing methods beyond 2000: what's now and next. *J.Neurosci.Methods* **103**, 1-2.
43. Lanciego, J. L. and Wouterlood, F. G. (2011). A half century of experimental neuroanatomical tracing. *J.Chem.Neuroanat.* **42**, 157-183.
44. Lazarov, N. E. (2013). Neuroanatomical tract-tracing using biotinylated dextran amine. *Methods Mol.Biol.* **1018**, 323-334.
45. Leergaard, T. B., Alloway, K. D., Mutic, J. J., and Bjaalie, J. G. (2000a). Three-dimensional topography of corticopontine projections from rat barrel cortex: correlations with corticostriatal organization. *J.Neurosci.* **20**, 8474-8484.
46. Leergaard, T. B., Alloway, K. D., Pham, T. A., Bolstad, I., Hoffer, Z. S., Pettersen, C., and Bjaalie, J. G. (2004). Three-dimensional topography of corticopontine projections from rat sensorimotor cortex: comparisons with corticostriatal projections reveal diverse integrative organization. *J.Comp Neurol.* **478**, 306-322.

47. Leergaard, T. B., Hilgetag, C. C., and Sporns, O. (2012). Mapping the connectome: multi-level analysis of brain connectivity. *Front Neuroinform.* **6**, 14.
48. Leergaard, T. B., Lyngstad, K. A., Thompson, J. H., Taeymans, S., Vos, B. P., De, Schutter E., Bower, J. M., and Bjaalie, J. G. (2000b). Rat somatosensory cerebropontocerebellar pathways: spatial relationships of the somatotopic map of the primary somatosensory cortex are preserved in a three-dimensional clustered pontine map. *J.Comp Neurol.* **422**, 246-266.
49. Mailly, P., Aliane, V., Groenewegen, H. J., Haber, S. N., and Deniau, J. M. (2013). The rat prefrontostriatal system analyzed in 3D: evidence for multiple interacting functional units. *J.Neurosci.* **33**, 5718-5727.
50. Majka, P., Kublik, E., Furga, G., and Wojcik, D. K. (2012). Common atlas format and 3D brain atlas reconstructor: infrastructure for constructing 3D brain atlases. *Neuroinformatics.* **10**, 181-197.
51. Malmierca, M. S., Leergaard, T. B., Bajo, V. M., Bjaalie, J. G., and Merchan, M. A. (1998). Anatomic evidence of a three-dimensional mosaic pattern of tonotopic organization in the ventral complex of the lateral lemniscus in cat. *J.Neurosci.* **18**, 10603-10618.
52. Manger, P. R., Cort, J., Ebrahim, N., Goodman, A., Henning, J., Karolia, M., Rodrigues, S. L., and Strkalj, G. (2008). Is 21st century neuroscience too focussed on the rat/mouse model of brain function and dysfunction? *Front Neuroanat.* **2**, 5.
53. Mathur, B. N., Caprioli, R. M., and Deutch, A. Y. (2009). Proteomic analysis illuminates a novel structural definition of the claustrum and insula. *Cereb.Cortex* **19**, 2372-2379.
54. Merchan, M. A., Saldana, E., and Plaza, I. (1994). Dorsal nucleus of the lateral lemniscus in the rat: concentric organization and tonotopic projection to the inferior colliculus. *J.Comp Neurol.* **342**, 259-278.
55. Mikula, S., Trotts, I., Stone, J. M., and Jones, E. G. (2007). Internet-enabled high-resolution brain mapping and virtual microscopy. *Neuroimage.* **35**, 9-15.

56. Moene, I. A., Subramaniam, S., Darin, D., Leergaard, T. B., and Bjaalie, J. G. (2007). Toward a workbench for rodent brain image data: systems architecture and design. *Neuroinformatics*. **5**, 35-58.
57. Naber, P. A., Witter, M. P., and Lopes da Silva, F. H. (2000). Differential distribution of barrel or visual cortex. Evoked responses along the rostro-caudal axis of the peri- and postrhinal cortices. *Brain Res*. **877**, 298-305.
58. Nikundiwe, A. M., Bjaalie, J. G., and Brodal, P. (1994). Lamellar organization of pontocerebellar neuronal populations. A multi-tracer and 3-D computer reconstruction study in the cat. *Eur.J.Neurosci*. **6**, 173-186.
59. Odeh, F., Leergaard, T. B., Boy, J., Schmidt, T., Riess, O., and Bjaalie, J. G. (2011). Atlas of transgenic Tet-Off Ca²⁺/calmodulin-dependent protein kinase II and prion protein promoter activity in the mouse brain. *Neuroimage*. **54**, 2603-2611.
60. Oh, S. W., Harris, J. A., Ng, L., Winslow, B., Cain, N., Mihalas, S., Wang, Q., Lau, C., Kuan, L., Henry, A. M., Mortrud, M. T., Ouellette, B., Nguyen, T. N., Sorensen, S. A., Slaughterbeck, C. R., Wakeman, W., Li, Y., Feng, D., Ho, A., Nicholas, E., Hirokawa, K. E., Bohn, P., Joines, K. M., Peng, H., Hawrylycz, M. J., Phillips, J. W., Hohmann, J. G., Wohnoutka, P., Gerfen, C. R., Koch, C., Bernard, A., Dang, C., Jones, A. R., and Zeng, H. (2014). A mesoscale connectome of the mouse brain. *Nature* **508**, 207-214.
61. Ohara, S., Inoue, K., Witter, M. P., and Iijima, T. (2009). Untangling neural networks with dual retrograde transsynaptic viral infection. *Front Neurosci*. **3**, 344-349.
62. Papp, E. A., Leergaard, T. B., Calabrese, E., Johnson, G. A., and Bjaalie, J. G. (2014). Waxholm Space atlas of the Sprague Dawley rat brain. *Neuroimage*. **97**, 374-386.
63. Paxinos, G. and Watson, C. (2007). *The Rat Brain In Stereotaxic Coordinates*. (Elsevier:
64. Peterson, D. L., Sheridan, P. J., and Brown, W. E., Jr. (1994). Animal models for brain tumors: historical perspectives and future directions. *J.Neurosurg*. **80**, 865-876.

65. Reiner, A., Veenman, C. L., Medina, L., Jiao, Y., Del, Mar N., and Honig, M. G. (2000). Pathway tracing using biotinylated dextran amines. *J.Neurosci.Methods* **103**, 23-37.
66. Schmitt, O. and Eipert, P. (2012). neuroVIISAS: approaching multiscale simulation of the rat connectome. *Neuroinformatics*. **10**, 243-267.
67. Schwarz, C. and Thier, P. (1995). Modular organization of the pontine nuclei: dendritic fields of identified pontine projection neurons in the rat respect the borders of cortical afferent fields. *J.Neurosci.* **15**, 3475-3489.
68. Sripanidkulchai, K., Sripanidkulchai, B., and Wyss, J. M. (1984). The cortical projection of the basolateral amygdaloid nucleus in the rat: a retrograde fluorescent dye study. *J.Comp Neurol.* **229**, 419-431.
69. Tekin, S. and Cummings, J. L. (2002). Frontal-subcortical neuronal circuits and clinical neuropsychiatry: an update. *J.Psychosom.Res.* **53**, 647-654.
70. Tomita, A., Kato, T., Sato, F., Haque, T., Oka, A., Yamamoto, M., Ono, T., Bae, Y. C., Maeda, Y., Sessle, B. J., and Yoshida, A. (2012). Somatotopic direct projections from orofacial areas of primary somatosensory cortex to pons and medulla, especially to trigeminal sensory nuclear complex, in rats. *Neuroscience* **200**, 166-185.
71. van Strien, N. M., Cappaert, N. L., and Witter, M. P. (2009). The anatomy of memory: an interactive overview of the parahippocampal-hippocampal network. *Nat.Rev.Neurosci.* **10**, 272-282.
72. Veenman, C. L., Reiner, A., and Honig, M. G. (1992). Biotinylated dextran amine as an anterograde tracer for single- and double-labeling studies. *J.Neurosci.Methods* **41**, 239-254.
73. Vercelli, A., Repici, M., Garbossa, D., and Grimaldi, A. (2000). Recent techniques for tracing pathways in the central nervous system of developing and adult mammals. *Brain Res.Bull.* **51**, 11-28.
74. Welker, E., Hoogland, P. V., and Van der Loos, H. (1988). Organization of feedback and feedforward projections of the barrel cortex: a PHA-L study in the mouse. *Exp.Brain Res.* **73**, 411-435.

75. Wise, S. P., Fleshman, J. W., Jr., and Jones, E. G. (1979). Maturation of pyramidal cell form in relation to developing afferent and efferent connections of rat somatic sensory cortex. *Neuroscience* **4**, 1275-1297.
76. Wise, S. P. and Jones, E. G. (1977). Somatotopic and columnar organization in the corticotectal projection of the rat somatic sensory cortex. *Brain Res.* **133**, 223-235.
77. Wong-Riley, M. (1979). Changes in the visual system of monocularly sutured or enucleated cats demonstrable with cytochrome oxidase histochemistry. *Brain Res.* **171**, 11-28.
78. Yushkevich, P. A., Piven, J., Hazlett, H. C., Smith, R. G., Ho, S., Gee, J. C., and Gerig, G. (2006). User-guided 3D active contour segmentation of anatomical structures: significantly improved efficiency and reliability. *Neuroimage.* **31**, 1116-1128.
79. Yushkevich, P. A. Avants B. B. Ng L. Hawrylycz M. Burstein P. D. Zhang H. & Gee J. C (2006). 3D Mouse Brain Reconstruction from Histology Using a Coarse-to-Fine Approach. *Lecture Notes in Computer Science* **4057**, 230-237.
80. Zakiewicz, I. M., Bjaalie, J. G., and Leergaard, T. B. (2014). Brain-wide map of efferent projections from rat barrel cortex. *Front Neuroinform.* **8**, 5.
81. Zakiewicz, I. M., van Dongen, Y. C., Leergaard, T. B., and Bjaalie, J. G. (2011). Workflow and atlas system for brain-wide mapping of axonal connectivity in rat. *PLoS.One.* **6**, e22669.
82. Zingg, B., Hintiryan, H., Gou, L., Song, M. Y., Bay, M., Bienkowski, M. S., Foster, N. N., Yamashita, S., Bowman, I., Toga, A. W., and Dong, H. W. (2014). Neural networks of the mouse neocortex. *Cell* **156**, 1096-1111.

