



University of HUDDERSFIELD

University of Huddersfield Repository

Shackleton, Philip

Benchmarks for rail vehicle dynamics simulation

Original Citation

Shackleton, Philip (2015) Benchmarks for rail vehicle dynamics simulation. In: FRA Vehicle-Track Simulation Software Workshop, 30 June - 01 July 2015, Volpe Center, Cambridge, MA. (Unpublished)

This version is available at <http://eprints.hud.ac.uk/25381/>

The University Repository is a digital collection of the research output of the University, available on Open Access. Copyright and Moral Rights for the items on this site are retained by the individual author and/or other copyright owners. Users may access full items free of charge; copies of full text items generally can be reproduced, displayed or performed and given to third parties in any format or medium for personal research or study, educational or not-for-profit purposes without prior permission or charge, provided:

- The authors, title and full bibliographic details is credited in any copy;
- A hyperlink and/or URL is included for the original metadata page; and
- The content is not changed in any way.

For more information, including our policy and submission procedure, please contact the Repository Team at: E.mailbox@hud.ac.uk.

<http://eprints.hud.ac.uk/>

FRA VTI Modelling Best Practices Workshop

Dr Phil Shackleton

Cambridge, MA

30th June – 1st July 2015

Inspiring tomorrow's professionals

THE AWARDS
AWARD WINNER
UNIVERSITY OF THE YEAR

the guardian
UNIVERSITY
AWARDS
Winner
2013

2012
THE AWARDS
WINNER
Entrepreneurial University of the Year



Summary

- Overview of the Institute of Railway Research (IRR)
- Why benchmark?
- Recent benchmarking exercises
- Key learning points
- Gaps and opportunities
- Benchmark requirements

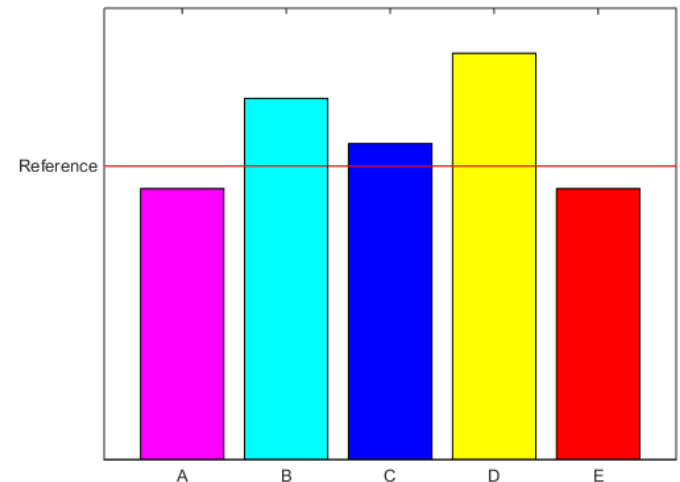

Summary

- Overview of the Institute of Railway Research (IRR)
- Why benchmark?
- Recent benchmarking exercises
- Key learning points
- Gaps and opportunities
- Benchmark requirements

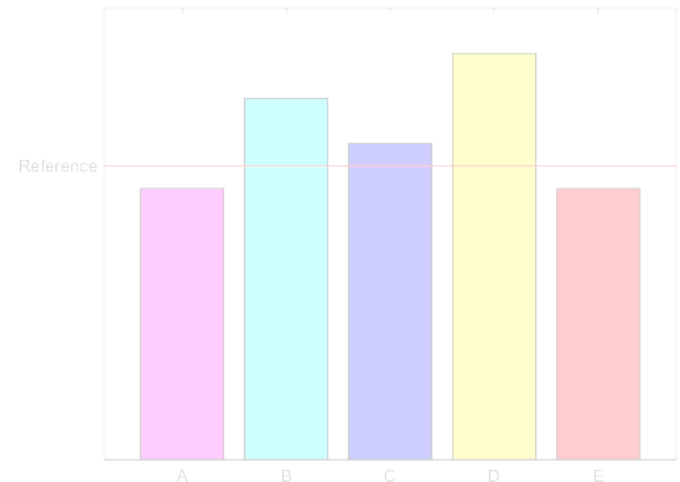

IRR – Structure and team



Institute of Railway Research:

- Management Team

Centre for Innovation in Rail

- 17 Researchers + 1 MSc administrator

RSSB Strategic Partnership

- 1 Professor
- 9 Researchers

IRR Research

- 6 Research staff
- 2 Professors

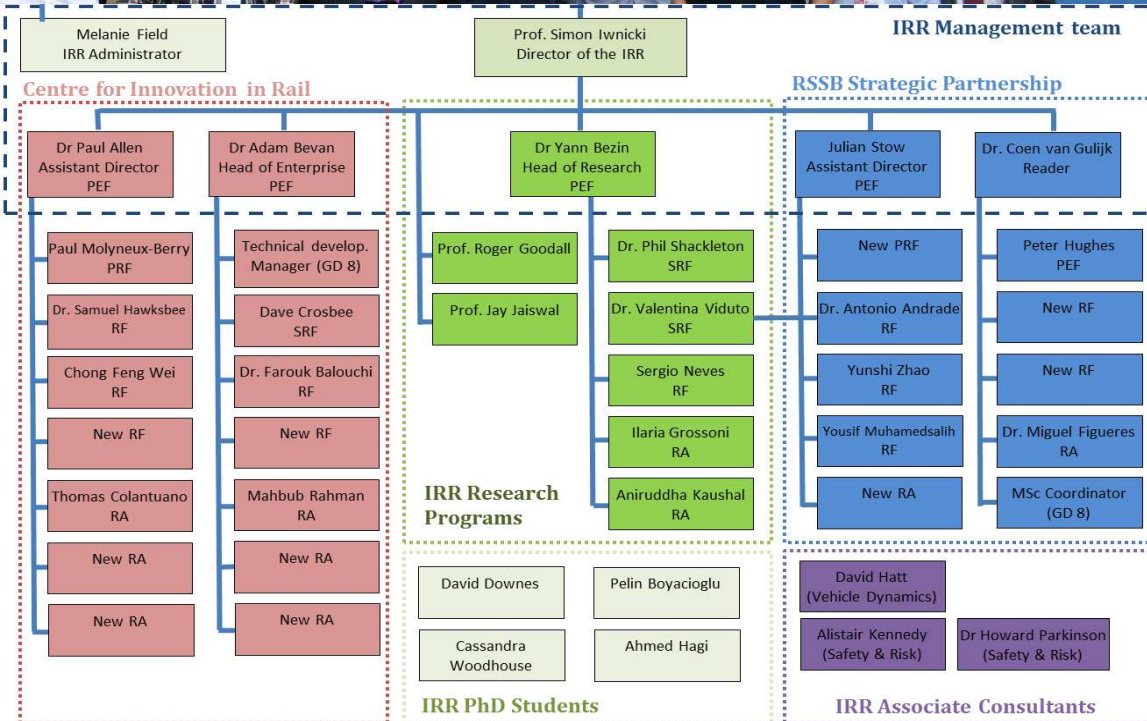

IRR Core Research Areas



Wheel-Rail Interaction: Modelling wheel-rail contact and resulting damage (wear, rolling contact fatigue corrugation etc). Methods of optimising the interface for heavy rail, light rail and metro systems.



Railway Vehicle Dynamics: Vehicle track interaction, derailment analysis, vehicle acceptance procedures and performance optimisation for heavy rail, light rail and metro vehicles.

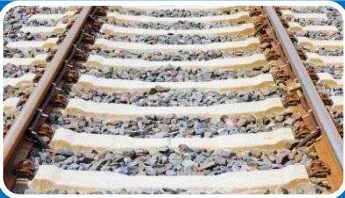

Track-system Dynamics: Modelling of complete trackforms and vehicle interaction. Predictions of force distributions, track and fixing response and structural resistance. Trackform design and failure mode investigations.



Instrumentation and Condition Monitoring: Vehicle and track mounted measurement systems, condition monitoring and asset life optimisation.

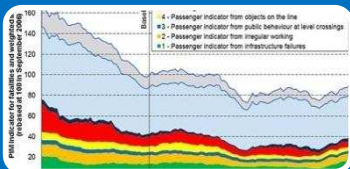

Railway Safety and Risk: safety/risk modelling, data trend analysis, safety system development, societal risk (e.g. modal shift), SPAD analysis, integrating engineering and risk tools.

Veh.Track.Interaction Research Tools

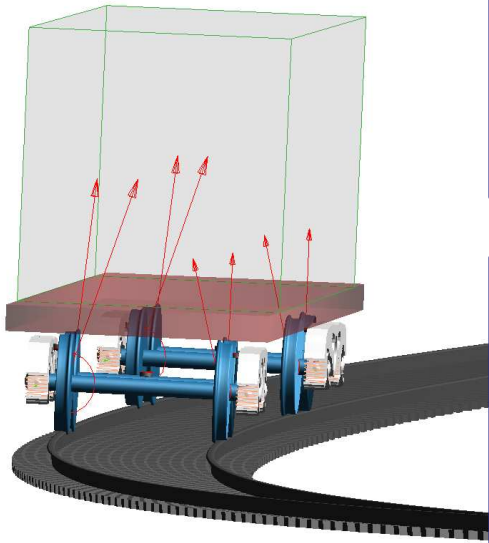

Vehicle dynamics

- Vampire
- Vi-Rail
- Simpack

VAMPIRE

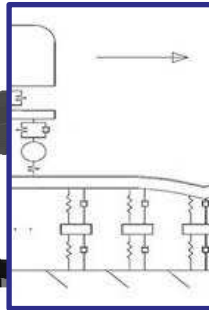

Vehicle track interaction

- Coupled vertical dynamic models (Matlab)
- Coupled vertical/lateral dynamics (Matlab)
- Flexible Track System Model (VI-Rail)

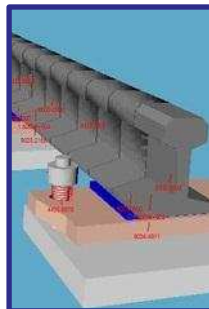

Track system modelling

- FTSM (VI-Rail and Matlab)

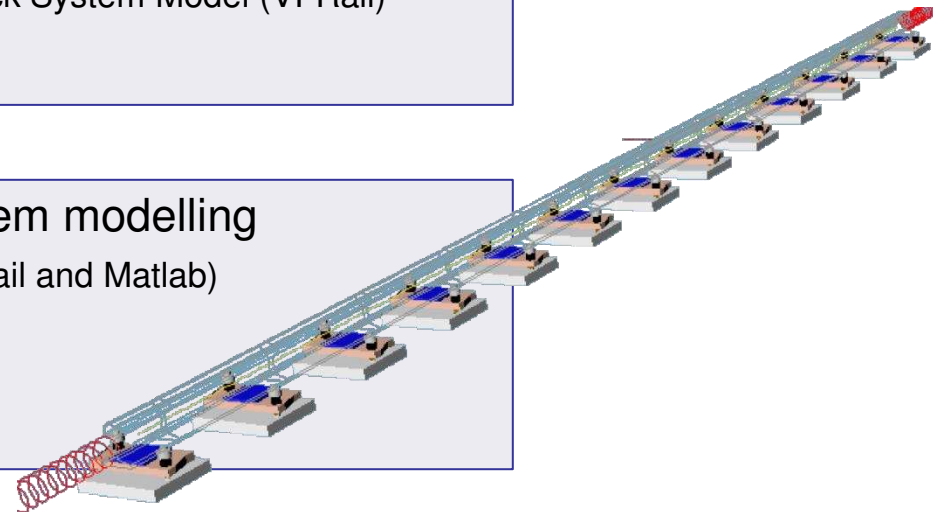

New test facility for 2016

University of
HUDDERSFIELD
Institute of Railway Research

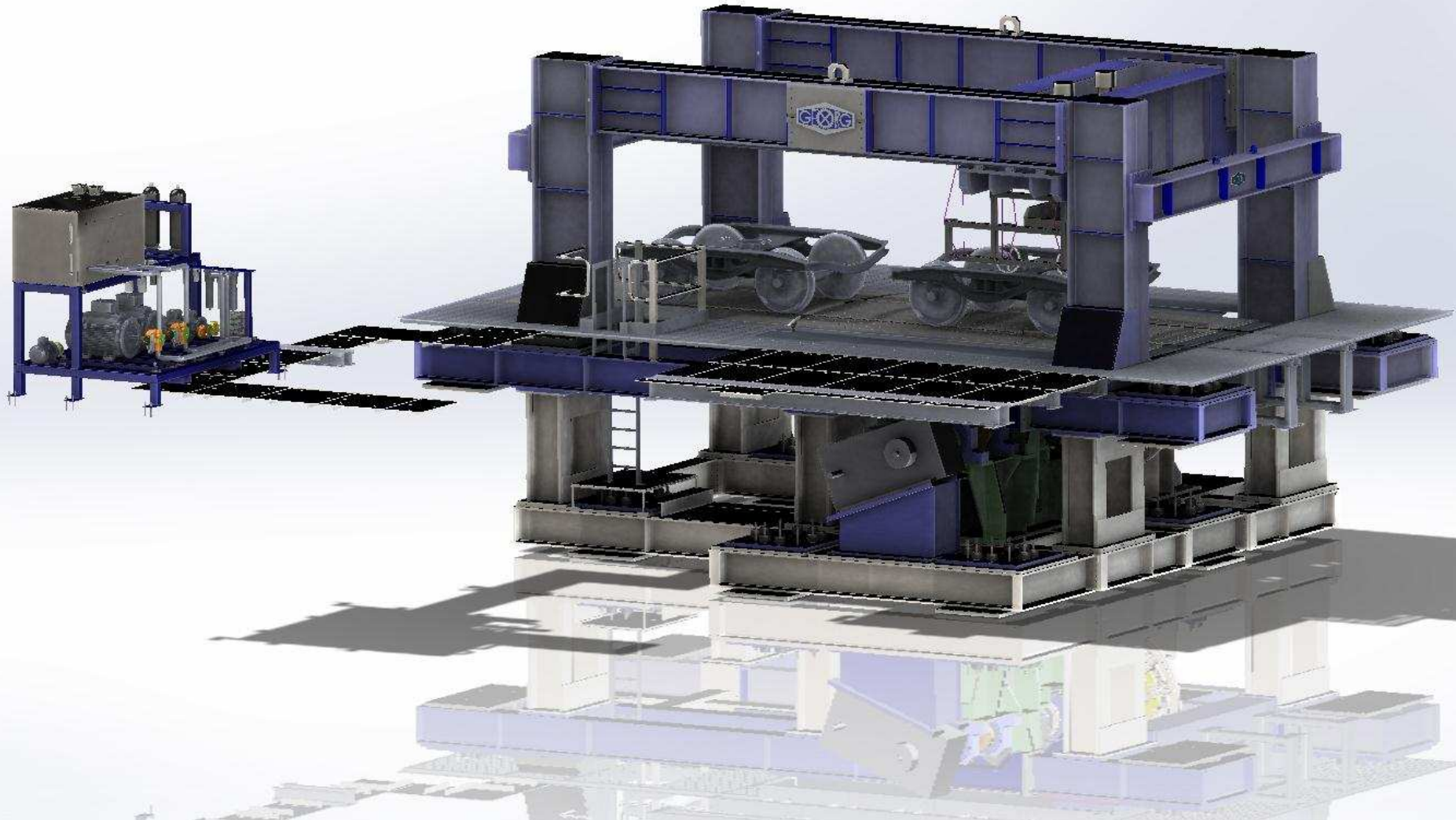

New test facility for 2016

University of
HUDDERSFIELD
Institute of Railway Research

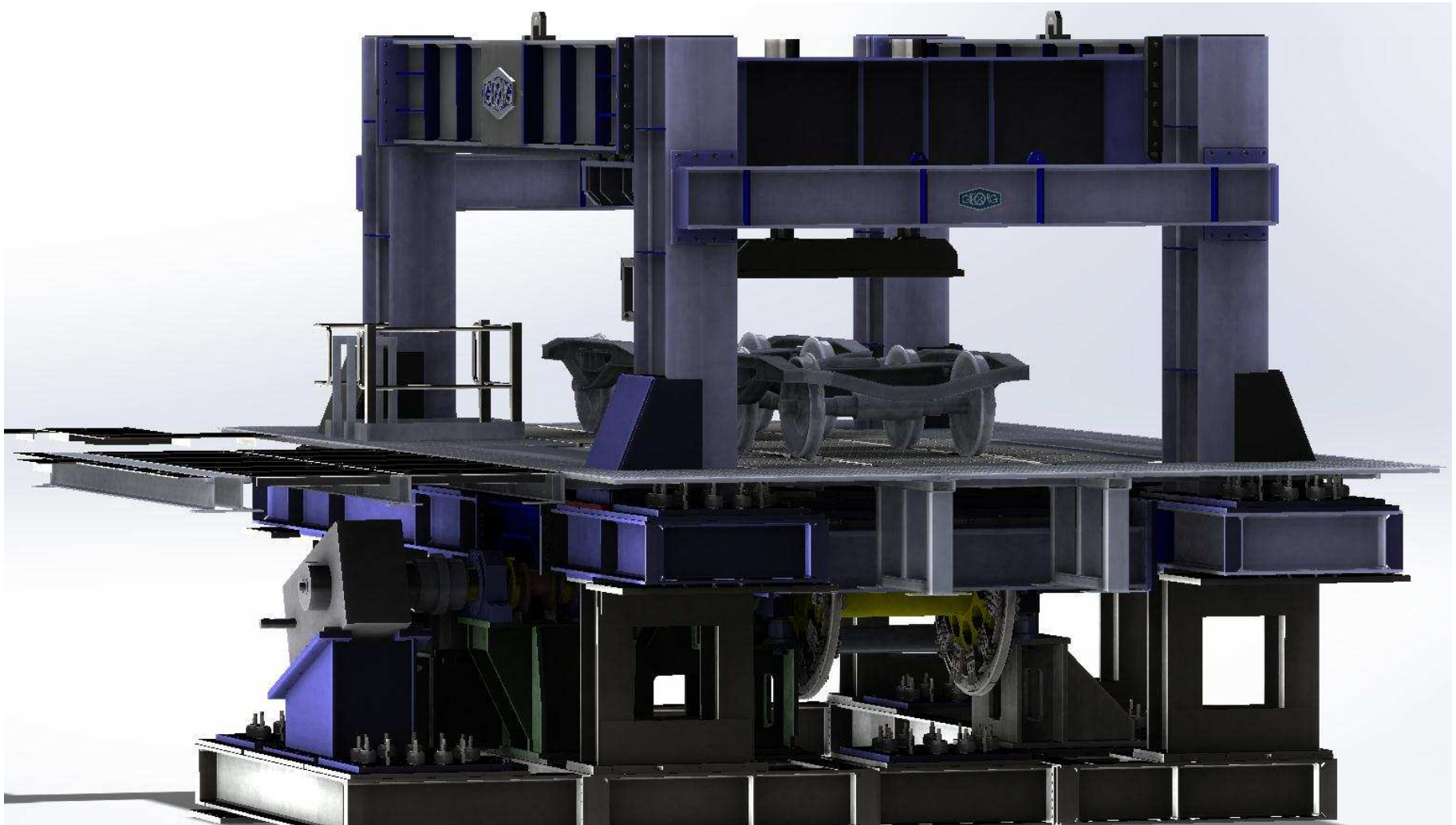

Summary

- Overview of the Institute of Railway Research (IRR)
- **Why benchmark?**
- Recent benchmarking exercises
- Key learning points
- Gaps and opportunities
- Benchmark requirements

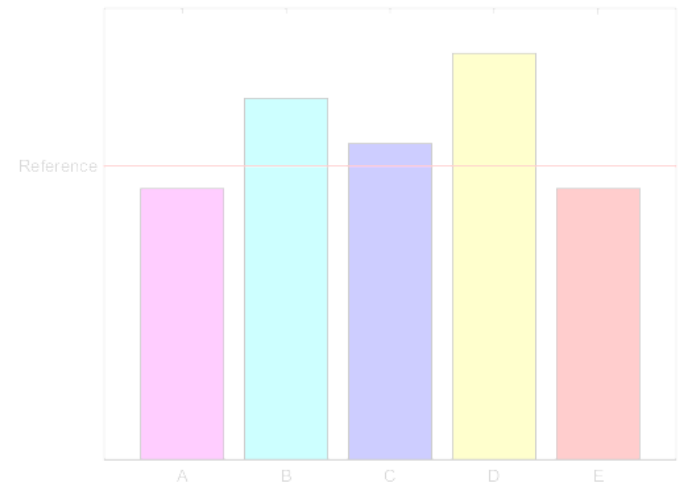

Why Benchmark?

- Verification
- Identify and quantify the effects of approximations, simplifications and compromises made
 - Range and sensitivity of input parameters
 - Implementation
 - Ease of use
 - Speed
 - Computational resources
 - Versus accuracy

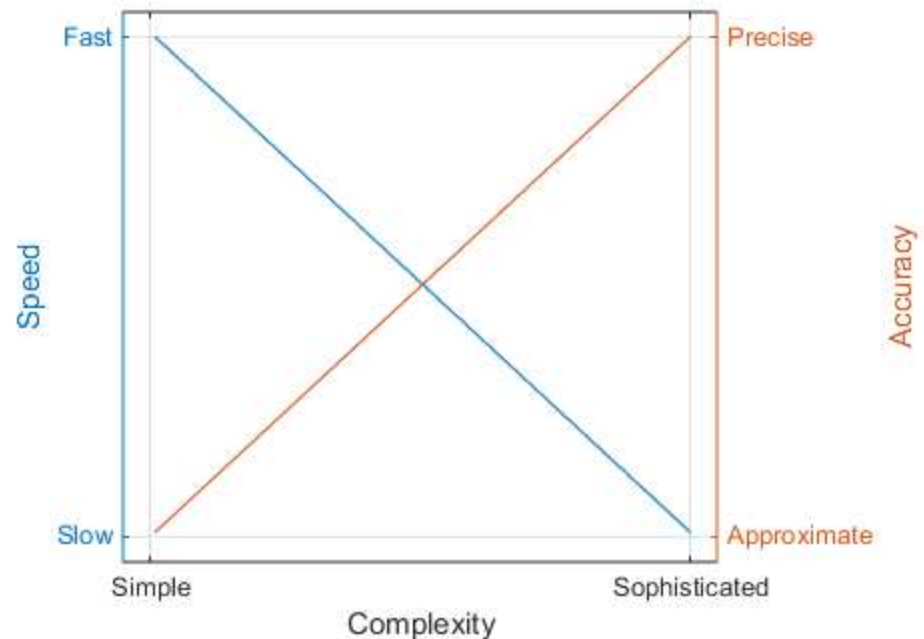

Why Benchmark?

- Provide reassurance & confidence in the use of the software tools
 - When multiple codes with differing approaches, background or philosophies agree
 - Support increased use (e.g. in design and acceptance)
 - Reduce physical testing
- Provide a platform for developers to corroborate/validate new codes and methods
 - Could/can also propagate errors or bad practice or:
 - Lead to good matches in only one area
- Identify gaps in performance or knowledge and opportunities
 - Drive future developments

Summary

- Overview of the Institute of Railway Research (IRR)
- Why benchmark?
- **Recent benchmarking exercises**
- Key learning points
- Gaps and opportunities
- Benchmark requirements

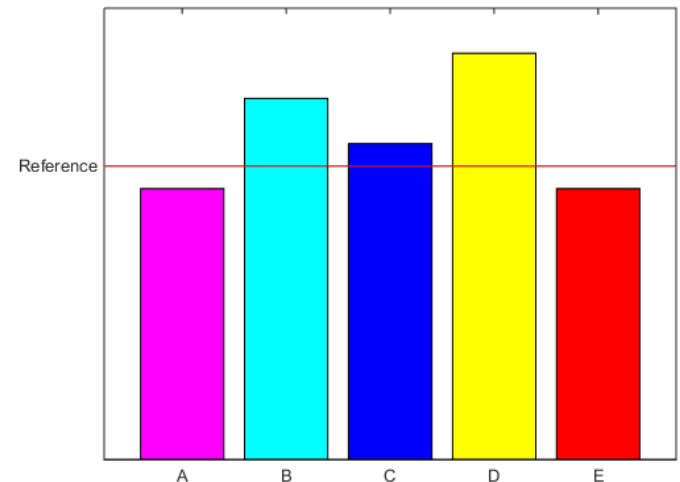

Benchmarks for Rail Dynamics

- ERRI B176/3 (1993)
- Multi-body computer codes in vehicle system dynamics (1993)
- Models of railway track and vehicle/track interaction (1994-6)
- Manchester benchmarks for rail vehicle dynamics (1998/9)
- Benchmark test for models of railway track dynamic behaviour (2004/5)
- LD Benchmark (2008)
- Manchester Contact Benchmark (2008)
- Miscellaneous research articles

Multi-body computer codes in vehicle system dynamics (1993)

Kortüm, W. & Sharp, R.S.

- Area covered:
 - Wheel-rail contact forces
 - Vehicle dynamics - vehicle response
- Aimed to ascertain:
 - The process used to solve the problem
 - The level of skill required
 - The time taken
 - The resources required and efficiency
- Conclusions (rail dynamics specifically):
 - Contact modelling approach has a strong influence on the dynamic result
 - The approach used for modelling the springs should be done very carefully for the different arrangements used in practice
 - High frequency components play a major part in output. Similar filtering should be used when comparing signals
- Conclusions (benchmarking general)
 - The values of benchmarking lie in:
 - The precise specification of the problem
 - The provision of a “correct” solution to which the new solutions can be compared
 - The exposure of key open modelling areas, which are shown as crucial to obtaining good results but which are not circumscribed by conventional wisdom
 - Recording results which relate the method, skill, effort and resource necessary as well the ability to solve the problem

Models of railway track and vehicle/track interaction (1994-6)

Knothe, K. & Grassie, S.L.

- Models of railway track and vehicle/track interaction (1994-6)
 - Split into high and low frequency
- Low frequency
 - Calculation of quantities for ride quality and track loading
 - Passenger coach
 - No references for results?
- High Frequency
- Aim:
 - Enable users to see the agreement between models for rigorously stipulated conditions
 - High frequency realm of noise, corrugation and track component damage
- Conclusions
 - The detail of the vehicle model appeared to be relatively significant
 - The Low Frequency model [MBD model] gave relatively poor correlation of most quantities
 - Time domain models benefited from accounting for low frequency phenomena [bow wave]
 - Difficulty in assessing the degree of correlation was noted
 - Both time and frequency domain models gave reasonable correlation (above exception)
 - Could not conclude calculations were accurate due to absence of experimental data

Manchester Benchmarks for Rail Vehicle Simulation (1998/9)

Iwnicki, S.

- Area covered:
 - Vehicle dynamics – vehicle response
- Aims:
 - To allow assessment of the suitability of the various software packages that now exist for simulation of vehicle dynamics
 - To explore the possibility of an approved list of packages to be used interchangeably by railway organisations
- It did not aim to:
 - Provide accurate validation of the software packages
- Conclusions:
 - It was difficult to draw clear conclusions
 - Generally good agreement between packages was noted
 - Users should have confidence of a similar result using an alternative package
 - The treatment of contact patch elasticity requires further work
 - There is no agreement on the method used to determine the exact location of the contact patch and the point at which the contact forces act
 - Those variations did not lead to large differences in the overall results and are insignificant
 - The case may exist where these small differences become important



Benchmark test for models of railway track dynamic behaviour (2004/5)

Leong, J., Murray, M., Steffens, D.

- Area covered:
 - Vehicle and track dynamics
 - Rail and track response
- Aim:
 - Examine the capabilities of available track dynamics models against measurements of real track behaviour
 - Assist railway engineers in selecting the railway dynamic model that would be most suitable for their specific requirements
- Conclusion:
 - None of the benchmark participants were able to produce results that were consistently comparable to either:
 - Field data
 - Other models
 - Each model had particular strengths and the practising engineer must consider those strengths for a given need

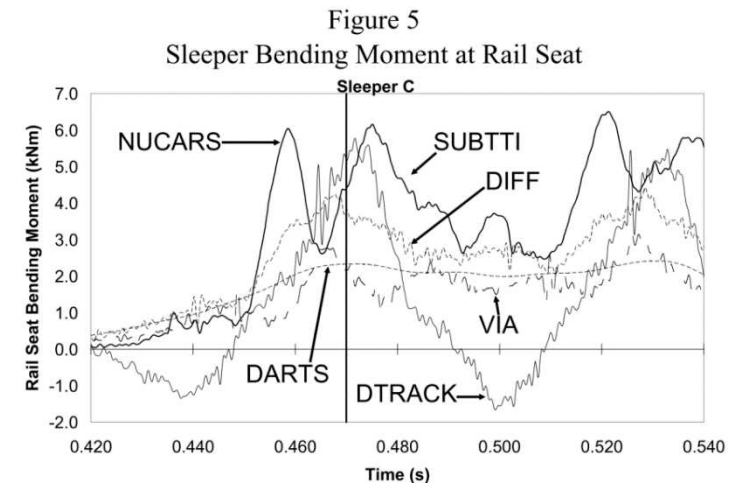

LD Benchmark (2008)

Marquis, B. & Pascal, J.-P.

- Area covered:
 - The benchmark involved the computation of contact forces resulting from elastic impact of wheel flanges on stiff track
 - Typical of conditions associated with higher speed derailments
- Aim:
 - Analyse normal contact force calculations and modelling of flanging with impacts
 - Understand how different modelling assumptions influence the results
 - Promote technology transfer to produce more consistent predictions
- Conclusions:
 - For flanging impacts results are very sensitive to input parameters
 - Parametric studies are required for assessing derailment risk for the studied mechanism
 - When input parameters and modelling assumptions were the same good agreement between codes was observed

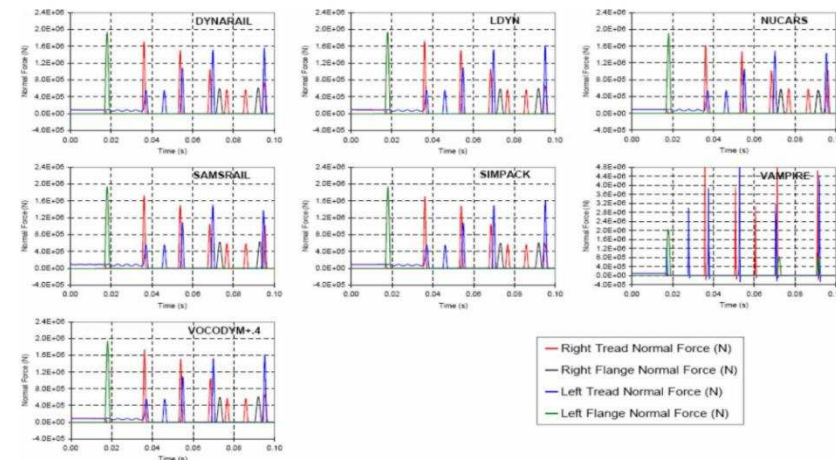

Figure 5. Normal forces of exercise 3S, initial lateral velocity = 1 m/s.

Shackleton, P. & Iwnicki, S.

- Area covered:
 - Investigate the difference in wheel rail contact parameters predicted by different models
 - Investigate the effects of the different contact models on dynamic vehicle simulations
- Aim:
 - Allow an informed choice of wheel-rail contact model for railway simulations
 - To help inspire direction for future wheel-rail contact research
- Conclusions:
 - The method of constraint for the wheelset was not specified and differing implementations affected the results presented
 - For certain applications (such as wear calculations) results could be significantly affected by the contact model used
 - The second part of the benchmark “Case B” – to investigate the effects on dynamic vehicle simulation – was never undertaken

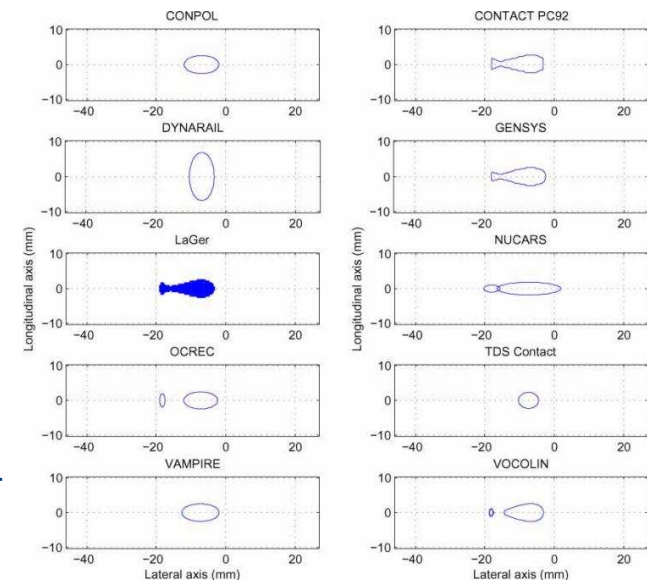
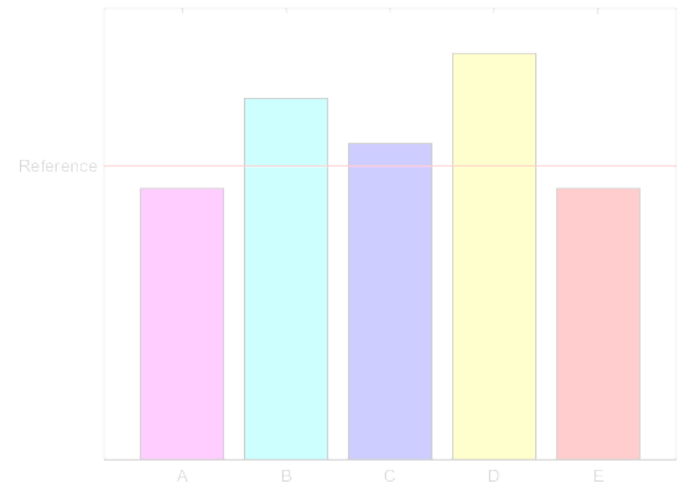

Figure 13. The contact patch shapes and position at the right wheel–rail interface size for Case A1.1 new profiles 20 kN load. The contact positions are defined in the local rail coordinate system (0 mm lateral displacement).

- A multitude of comparative research
- Not necessarily set out as a benchmark exercise they can often partially serve the purposes of one
- Normally the work sets out to prove a specific point
 - Scenarios can be quite specific
 - Emphasis often on the benefits of new methods over existing
 - A balanced comparison not always presented
 - The consequences for the general case may not be obvious
- Identify and fill gaps in the state of the art
- Help drive best practices
- Can help justify more comprehensive benchmarking exercises

Summary

- Overview of the Institute of Railway Research (IRR)
- Why benchmark?
- Recent benchmarking exercises
- **Key learning points**
- Gaps and opportunities
- Benchmark requirements



Conclusions from recent benchmarks

- Vehicle dynamic response
 - Good agreement in multi-body dynamic response can be achieved
 - Where the benchmark conditions are clearly specified and interpreted in the same way
 - Differences in output are normally attributed to differing modelling philosophies (e.g. contact model) or differing interpretation of specifications
 - Subjective factors such as user skill required, ease of implementation and time required to construct models are not well compared
 - There appears to be little need for further verification of multi-body codes themselves
 - Simulation packages and codes provide correct answers for the given input parameters

- **Wheel-rail contact**
 - There is agreement that the contact model or philosophy used affects the outcome of dynamic simulations
 - In certain areas can be significant
 - E.g. post-processing for wear and RCF prediction, high speed derailment
 - Quantification of the errors/variation expected in dynamic vehicle response is not well established
 - E.g. what level of sophistication is necessary for derailment analysis, gauging, curving, etc.
 - How do errors attributable to wheel-rail contact compare to other errors and uncertainties (e.g. component degradation, tolerances, etc.)
- **Track dynamics**
 - Consistently comparable output from codes has not been demonstrated
 - Different codes providing different answers – low confidence in outputs might be inferred
 - Complex models require a wide range of precise inputs (which might not be precisely known)
 - There is not wide agreement in the modelling approach/assumptions/philosophy used
 - Opportunity for quantifying the influence of track model on vehicle response

Summary

- Overview of the Institute of Railway Research (IRR)
- Why benchmark?
- Recent benchmarking exercises
- Key learning points
- **Gaps and opportunities**
- Benchmark requirements

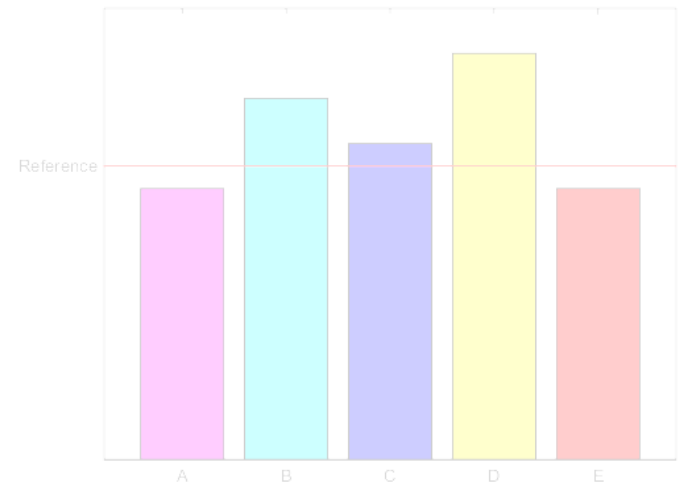

- Wheel-rail contact – more could be done
 - Relating wheel-rail contact model to variation in dynamic or quasi-static vehicle response
 - Quantify differences expected in wear and RCF calculations
 - Provide guidance for use in asset life management
 - Increase confidence in asset life predictions
- Latest benchmark for vehicle dynamics packages is somewhat dated
 - Is there a clear need to repeat benchmark?
 - Benchmarking simulation codes against measurement data is lacking
- Benchmark modelling techniques and element representation
 - E.g. varying detail of friction suspension and effects in accuracy observed
 - Identify the optimum detail versus modelling efficiency balance

- Track model

- Far less validation for track
- Influence of track model on vehicle response
- Consequences of variation in higher frequency output for post processing activities (e.g. S&C damage)
- Innotrack recommended further benchmark studies to build on work of Leong and Steffens

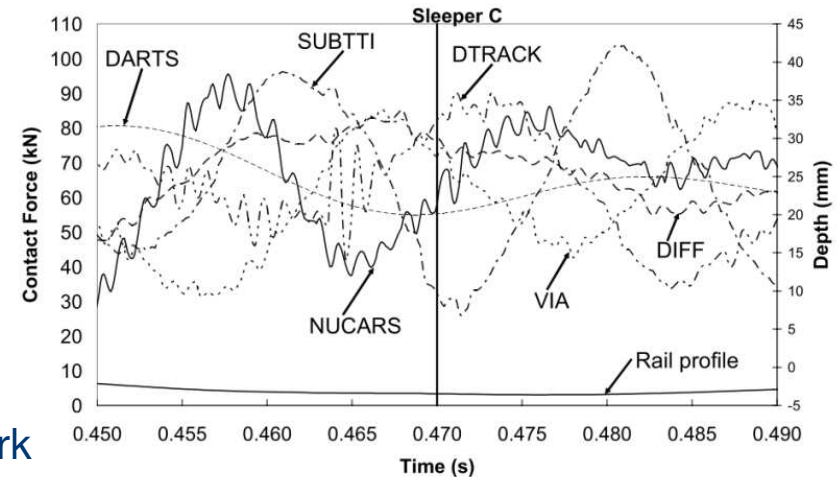

- The representation and necessity of vehicle flexible bodies

- Required modes for differing uses
- Requisite accuracy of modal data

Gaps and opportunities for benchmarking

- Quantification of the effects of the subjective and uncertainty factors associated with developing a validated vehicle model
 - DynoTrain sought to reduce the influence of subjectivity on validation
 - Simulation versus measurement data
 - No published simulation-simulation comparisons?
 - Effects of residual subjectivity
 - Correlation between independent models could further increase confidence
 - Particularly near limit cases
 - Reality of imperfect validation and/or test data
 - Fitting model response to test data
 - Non-unique solutions (e.g. sway tests matching)
 - Vertical CoG or suspension geometry?
 - Consideration of uncertainties and unknowns

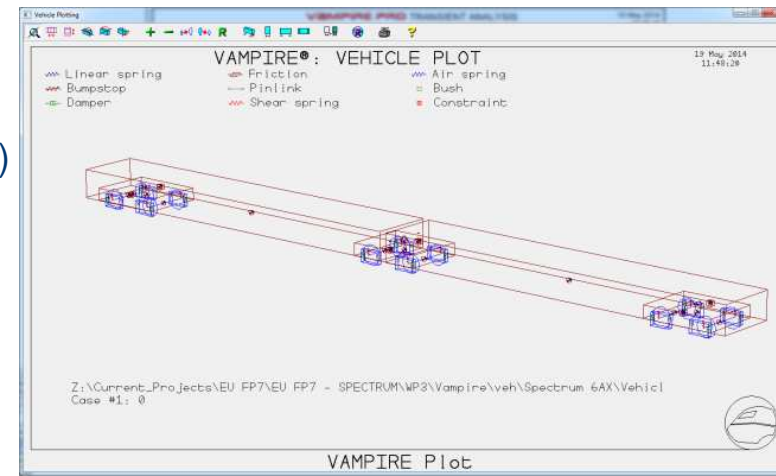

- Quantification of effects associated with input data qualities
 - Guide best practices
 - Requirements to avoid ambiguous implementation
 - Frequency content and resolution of time and distance data
 - Data pre-processing e.g. worn profile smoothing or resampling
 - Spatial resolution of measured rail profiles
- Methods used to quantify benchmark results
 - Frequency content and resolution of time and distance data
 - Data post-processing
 - E.g. filtering and statistical representation
 - Quantifiable correlation metrics
 - Comparators for expertise and user time required
 - Help drive cost reduction for end users
 - Increase use
 - Lower skill level
 - Shorter time or greater productivity

Gaps and opportunities for benchmarking

- Precision or variation - which is more informative:
 - Likely dependent on the specific realm of simulation
- Given finite resources we might aim to:
 - Solve one (or a small number) of scenarios very precisely
 - More useful for improving understanding the problem
 - Solve wide variations of a scenario less precisely
 - Can account for a range of uncertainty and real world variation
- Which combinations of sophistication are appropriate?
- Consider:
 - Nominal scenario high precision (top left)
 - Fringe scenario with variation (top right)
 - Fringe scenario high precision (bottom left)
 - Nominal scenario with high precision and compensation for variations and uncertainties OR:
 - Nominal scenario with variation (bottom right)

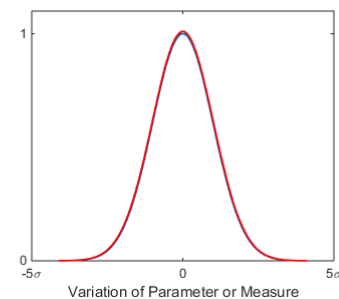
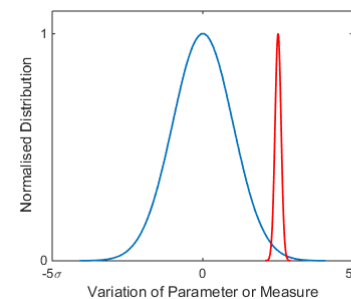
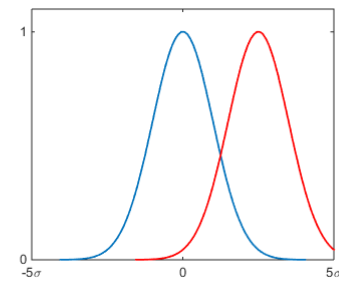
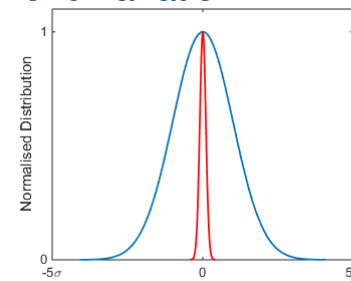

Summary

- Overview of the Institute of Railway Research (IRR)
- Why benchmark?
- Recent benchmarking exercises
- Key learning points
- Gaps and opportunities
- **Benchmark requirements**

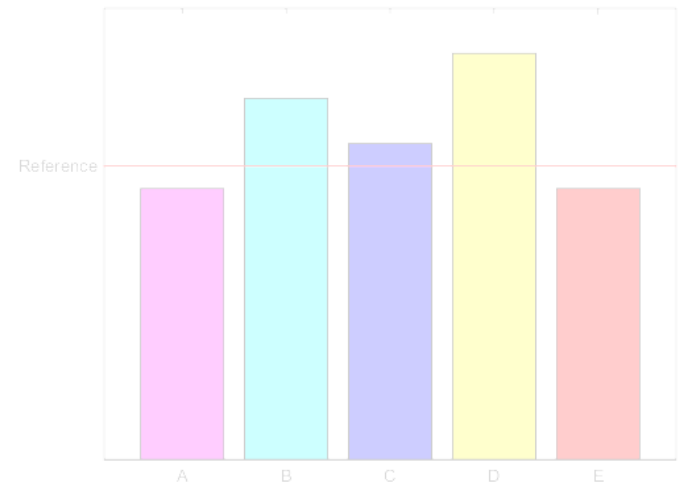

Benchmark requirements

- A need
 - Verification
 - Instil greater confidence in the application
 - Drive future developments
 - Identify gaps and deficiencies in the state of the art
 - Guide best practice
- Subject
 - Benchmarking the entire vehicle-track dynamic system would be ambitious
 - Conclusions would be difficult to draw
 - A small or isolated benchmark subject allows clearer comparisons and conclusions
 - Increased difficulty in relating conclusions to the more complex case
- Benchmark conditions
 - Clearly defined
 - Unambiguous (unless desired...)
 - Unwanted effects from 'externalities' of the subject must be controlled or removed

Benchmark requirements

- Participants/contributors
 - Most larger benchmarks have been an open call for contributions
 - Distribute workload
 - Ensure expert implementation of codes
 - Removes the inference of any partiality

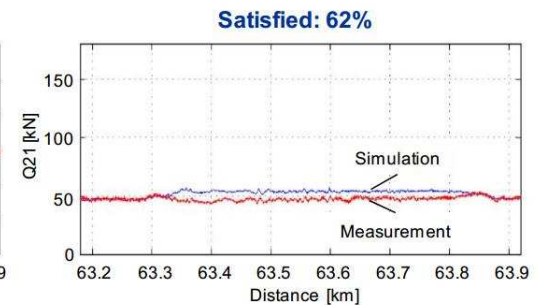
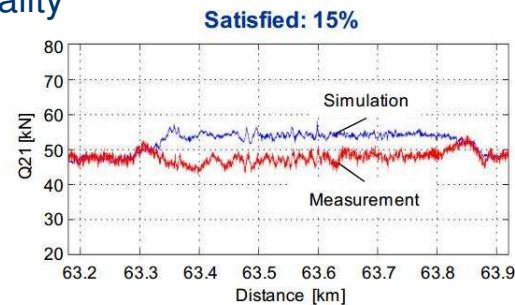

- Appropriate comparison methods and metrics
 - Measurement or experimental data increases scope of activity, however:
 - “...validation examples may alter from a model justification to a justification and correction of the measurement inexactness.” (Polach & Evans)
 - Validation metrics in DynoTrain did not provide sufficient contribution towards objective and reliable validation – the same ought to apply to corroborative comparisons
 - Statistically derived metrics (EN14363)
 - Draw out pertinent conclusions

Summary

- Overview of the Institute of Railway Research (IRR)
- Why benchmark?
- Recent benchmarking exercises
- Key learning points
- Gaps and opportunities
- Benchmark requirements

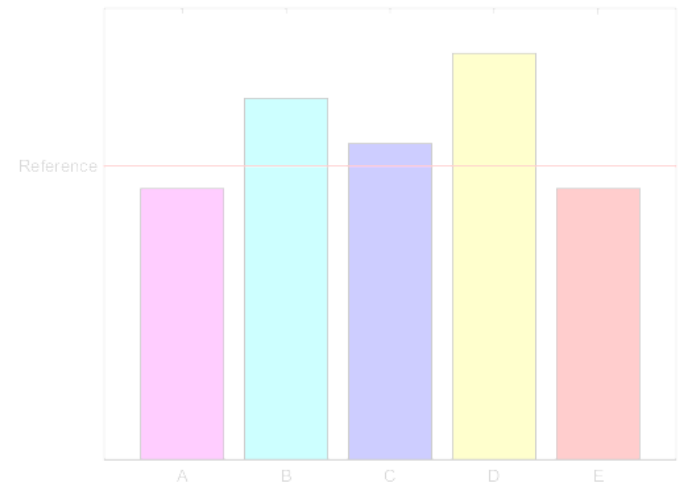

Bibliography

- *D1.3.6 The state of the art of the simulation of vehicle track interaction as a method for determining track degradation rates. Part 2 – High Resolution models and the level of validation generally*, Innotrack project deliverable, July 2009.
- *D5.5 – Final report on model validation process*, Dynotrain project deliverable. WP5 – Model building and validation, June 2013
- ERFI B176/3, *Benchmark problem – Results and assessment*, B176/DT290, Utrecht 1993. *Note: Original text not obtained but cited in several references below.*
- EN 14363:2005, *Railway applications—Testing for the acceptance of running characteristics of railway vehicles—Testing of running behaviour and stationary tests*, CEN, Brussels, 2005.
- GM/RT2141, Issue 3, *Resistance of Railway Vehicles to Derailment and Roll-Over*, RSSB, London, June 2009.
- GM/RC 2641, Issue 2, *Recommendations for Vehicle Static Testing*, RSSB, London, June 2009.
- GM/TT 0088, Issue 1, *Permissible Track Forces for Railway Vehicles*, British Railways Board, October 1993.
- Grassie, S. L., *Models of Railway Track and Vehicle/Track Interaction at High Frequencies: Results of Benchmark Test*, Vehicle System Dynamics, 1996.
- Iwnicki, S., *Manchester Benchmarks for Rail Vehicle Simulation*, Vehicle System Dynamics 30(3-4), 295-313, 1998
- Iwnicki, S., *Results of the Manchester Benchmarks*, Vehicle System Dynamics, Supplement 31, 2-12, 1999
- Kortüm, W., Sharp, R.S. (editors), *Multibody computer codes in vehicle system dynamics*, Vehicle System Dynamics Supplement 22, Swets & Zeitlinger 1993.
- Knothe, K., *Benchmark Test for Models of Railway Track and of Vehicle/Track Interaction in the Low Frequency Range*, Vehicle System Dynamics Supplement, 24, 363-379, Swets & Zeitlinger, 1995.
- Leong, J., Murray, M., Steffens, D., *Examination of Railway Track Dynamic Models Capabilities Against Measured Field Data*, International Heavy Haul Conference Specialist Technical Session, High Tech in Heavy Haul, Kiruna, Sweden 2007.
- Marquis, B., Pascal, J.-P., *Report on a railway Benchmark simulating a single wheelset without friction impacting a rigid track*, Vehicle System Dynamics, 46(1-2), 93-116, Taylor & Francis 2008.
- Polach, O., Böttcher, A., *A New Approach to Define Criteria for Rail Vehicle Model Validation*, 23rd International Symposium on Dynamics of Vehicle on Roads and Tracks, Qingdao, China, 2013.
- Polach, O., Evans, E. *Simulation of Running Dynamics for Vehicle Acceptance: Application and Validation*, 2nd International Conference on Railway Technology: Research, Development and Maintenance (RAILWAYS 2014), Corsica, 2014
- Shabana, A. A., Sany, J. R., *A Survey of Rail Vehicle Track Simulations and Flexible Multibody Dynamics*, *Nonlinear Dynamics 26: 179–210*, Kluwer Academic Publishers 2001
- Shackleton, P., Iwnicki, S., *Comparison of wheel–rail contact codes for railway vehicle simulation: an introduction to the Manchester Contact Benchmark and initial results*, Vehicle System Dynamics, 46(1-2), Taylor & Francis, 2008.
- Steffens, D. M., *Identification and Development of a Model of Railway Track Dynamic Behaviour – Doctoral Thesis*, Queensland University of Technology, 2005.
- Vollebregt, E. A.H., Iwnicki, S. D. Xie, G., Shackleton, P., *Assessing the accuracy of different simplified frictional rolling contact algorithms*, Vehicle System Dynamics, 50(1), 1-17, Taylor & Francis 2012.
- Wilson, N., Fries, R., Witte, M., Ilaigmoser, A., Wrang, M., Evans, J., Orlova, A., *Assessment of safety against derailment using simulations and vehicle acceptance tests: A comparison of the state-of-the-art worldwide*, Vehicle System Dynamics. 49(7), 1113-1157, 2011.