

Dynamic network model of banking system stability

Mengyang Wei¹, Miguel Leon-Ledesma², Gianluca Marcelli¹ and Sarah Spurgeon¹

Abstract

This paper presents a dynamic model of banking interactions, which uses interbank connections to study the stability of the banking system. The dynamic model extends previous work on network models of the banking system taking inspiration from large scale, complex, interconnected systems studied within the domain of engineering. The banking system is represented as a network where nodes are individual banks and the links between any two banks consist of interbank loans and borrowing. The dynamic structure of the model is represented as a set of differential equations, which, to the best of our knowledge, is an original characteristic of our approach. This dynamic structure not only allows us to analyse systemic risk but also to incorporate an analysis of control mechanisms. Uncertainty is introduced in the system by applying stochastic shocks to the bank deposits, which are assigned as an exogenous signal. The behaviour of the system can be analysed for different initial conditions and parameter sets. This paper shows some preliminary results under different combinations of bank reserve ratios, bank capital sizes and different degrees of bank interconnectedness. The results show that both reserve ratio and link rate have a positive effect on the stability of the system in the presence of moderate shocks. However, for high values of the shocks, high reserve ratios may have a detrimental effect on the survival of banks. In future work, we will apply strategies from the domain of control engineering to the dynamic model to characterise more formally the stability of the banking network.

Keywords: Systemic risk, banking system; differential equations, financial stability, Contagion.

JEL classification: C63, C90

¹ School of Engineering and Digital Arts, University of Kent, Canterbury, UK

² School of Economics, University of Kent, Canterbury, UK

1. Introduction

The financial crisis that occurred in 2008-2009 has driven financial regulators (e.g. central banks) and researchers to revisit ways of modelling the banking system. Traditionally, financial regulation was primarily focused on managing the risk of individual banks by requiring them to keep sufficient reserves to safeguard against the inherent risk of their own investments. Since the systemic risk arising from links between banks (e.g. interbank borrowing and lending) are ignored, a failure of even a small number of banks may spread systemically causing paralysis of the banking system. Thus, it has been suggested that to improve financial stability through regulation, more attention should be given to systemic risk, rather than to each individual institution (John Kay, 2012)(Andrew Haldane, 2012). The work published in Basel III: A global regulatory framework for more resilient banks and banking systems (2010) ("Basel III," 2011), points out the importance of the stability of the banking sector. As banks are at the centre of the credit intermediation process between savers and investors, a strong and resilient banking system is a foundation for sustainable economic growth.

The need for managing systemic risk has persuaded financial operators to consider a new framework that recognizes the interconnected nature of the banking system. Many central banks and other financial regulators have started to improve their financial management from a macro-prudential perspective, which aims to mitigate the risk of the financial system as a whole (Kern, 2012). Research effect on macro prudential policies has grown, mainly focusing on its implementation, effectiveness and relationship with monetary policy. A summary literature review can be found in (Galati and Moessner, 2013), which concludes that there are limited analytical tools and data available to check the effectiveness of macro prudential policies. A recent IMF Working Paper (Eugenio Cerutti et al., 2015) gives new evidence that macro-prudential policies can have a significant effect on credit developments, but the effectiveness is instrument and country specific and is less effective in financial bust.

One key issue about systemic risk management is how to measure the systemic risk. Different kinds of research has been done. One approach uses balance sheet data to establish links between banks or to derive banking system loss. Davies et al., 2010 assesses risks to financial stability by assessing a small number of key vulnerabilities in the UK financial system and suggests actions that might be undertaken to mitigate their potential impact. As the balance sheet linkages between banks are assigned a priori, when an event affects the system, it is not possible to account for changes in the network structure of the banking system. Hence, they become of limited relevance in predicting losses. Another approach to assess systemic risk in the banking system seeks to build indexes of systemic risk based on two criteria: too big to fail (TBTF) and too interconnected to fail (TITF). Work based on these types of indexes tries to assess the role that particular institutions play in aggregate financial risk due either to their size, or to their connectedness with other banks. Measures such as MES (Marginal Expected Shortfall) or SRISK (systemic risk) have been proposed (Acharya et al., 2010)(Acharya et al., 2012)(Brownlees and Engle, 2010)(Greenwood et al., 2012)(F. S. Board, 2011). Benoit et al., 2013 made a comparison of these measurements. Its findings show that these measures fall short in capturing the multifaceted nature of systemic risk and the quest for a suitable measure of systemic risk is ongoing.

From the above review, it can be seen that there is still great potential for improving the management and measurement of systemic risk. The study in this paper looks at systemic risk from the control engineering perspective. Control engineering applies known theoretical frameworks to design systems with desired behaviours (Malik, 1998). Such designed systems are called closed loop systems. Historically the major application of control theory has been in engineering, which primarily deals with the design of control systems for industry. However nowadays as a general theory, control theory can be useful wherever feedback occurs. Successful application areas include ecosystems, physiology, climate modelling, and neural networks as well as finance. Many financial

problems have been studied using stochastic control (Fleming and Pang, 2004)(Pham, 2009) and optimal control (Kamien and Schwartz, 1991), such as portfolio allocation, quadratic hedging of options and the optimal selling of an asset. Optimal control in stochastic settings is at the very heart of most macroeconomic models. Most dynamic stochastic general equilibrium models are models of dynamic optimisation used to suggest the setting regulatory policies (Kendrick, 1976)(Kaas, 1998). The study in this paper plans to apply control theory tools to a dynamic network models of the banking system, aiming at minimizing the systemic risk.

Related literature

In order to apply control theory, a model of the banking system has to be developed appropriately, so that stability analysis can be implemented. Network models of systemic risk in macroeconomics in general are becoming increasingly important nowadays. (Iori et al., 2006) developed a network model and showed that size and connectivity of banks and the nature of their interconnectedness will affect the potential for contagion. When banks are homogeneous (i.e. of similar size), interbank lending plays an insurance role in stabilising the system while when the banks are heterogeneous, contagion effects may arise and systematically increase with connectivity. (Nier et al., 2007) developed a banking-system model composed of a number of banks that are connected by interbank linkages and studied how the likelihood of contagious (knock-on) defaults is affected by the level of capitalization, the degree of connectivity, the size of interbank exposures and the degree of concentration of the system. This work indicates that the connectivity improves the ability to buffer shocks when it is above a certain threshold, but will increase contagion when it is below a threshold. The effect of capitalization on contagious defaults is non-linear and the size of interbank liabilities tends to increase the risk of knock-on default. Work by May and Arinaminpathy, 2010 and Haldane and May, 2011 explores the interplay between complexity and stability in deliberately simplified models of financial networks by drawing analogies with the dynamics of ecological food webs and with networks within which infectious diseases spread. In this work, banks are nodes in the network and bank activities are classified into four categories: deposit, external assets, borrowing and lending. The borrowing and lending are the links between the banks. This structure will be extended and used in this paper, as explained later in section 2. In a recent paper (Acemoglu et al., 2015), a unified framework is developed for the study of how network interactions can function as a mechanism for propagation and amplification of microeconomic shocks. A fairly complete characterization of the structure of equilibrium is provided to enable ranking of different networks in terms of their aggregate performance.

Another line of literature is the interconnected system paradigm in control engineering, which consists of a collection of subsystems with interconnections between them and the interconnections are modelled within the dynamical equations. Such an interconnected system is suitable to model the banking system. The banking system can be seen as a network of nodes with interconnections between them. When using the interconnected systems approach to represent the banking system, and as the banks are characterized by geographical separation, the interconnected systems tend to operate in a decentralized manner. The purpose of applying control theory is to minimize the effect of uncertainty on the overall system behaviour. Decentralized output feedback control for interconnected systems is very topical. Since the dynamics of interconnected systems are usually highly nonlinear, a specific control tool called sliding mode control has also received much attention in the literature due to its capacity to deal with uncertain, nonlinear scenarios. Works by Yan et al.(2004, 2005, 2007, 2013) encompasses nonlinear system representations, uncertainty and unknown perturbations as well as limited available information in the framework. And looks at stability including conditions to investigate the effect of the structure of the interconnections on the overall system stability.

The existing literature shows that network models can simulate different network structures with different degrees of size, connectivity and concentration, which can address the issue of having

uncertainty and changing connectivity in the system, as opposed to macro-prudential management. Nevertheless, real banking systems are characterised by a more dynamic behaviour where feedback mechanisms may play an important role in preserving the system's stability. For this reason, the novel contribution is introducing a control systems engineering approach as a tool to monitor a dynamical/interconnected system and to assess the impact of feedback mechanisms on system stability.

This paper shows the details and the preliminary results of a banking-system model based on a set of differential equations, which has been designed to accommodate the application of control theory. The rest of paper is organized as follows. In Section 2, the dynamic network model extended from previous network model in the literature is introduced. Implementation and some simulations results of this dynamic model are shown in Section 3. Section 4 draws conclusions and highlights the future work.

2. Dynamic model

Extending the structure in Haldane and May, 2011, each bank in the model is characterised by six categories of activities as shown in Figure 1: deposits, D , interbank borrowings, B , interbank loans, L , investment, I , cash, C , and net-worth, $N=I+C+L-D-B$. The links between any two banks, i and j , are made by the interbank loans and borrowings, L_{ij} and B_{ij} see Figure 2. The banks and links between different banks will form the network. The differential equations characterising the model contain the time derivatives of the quantities D_i , C_i , I_i , L_{ij} and B_{ij} which prescribe the dynamics of the system. The differential equations are solved using Matlab Simulink in the form of a computer simulation (see below for details).

A set of differential equations have been developed to assign the dynamics of the different banks' activities. These equations will be introduced and explained in the following subsections.

Cash

The differential equation governing the change in time of the cash, $\frac{dC_i}{dt}$, of bank i is reported in equation 1:

$$\frac{dC_i}{dt} = \frac{dD_i}{dt} - \frac{dI_i}{dt} - g_i D_i + p_i I_i + \sum_{i \neq j} b_{ij} - \sum_{i \neq j} h_{ij} B_{ij} - \sum_{i \neq j} l_{ij} + \sum_{i \neq j} k_{ij} L_{ij} \quad (1)$$

In equation 1, $\frac{dD_i}{dt}$ represents the change in cash of bank i over time dt due to a change in deposits, while $-g_i D_i$ represents the reduction in cash over time dt due to the payment of interest to depositors. Similarly, $-\frac{dI_i}{dt}$ represents the reduction in cash due to new investments and $p_i I_i$ represents the increase in cash due to the receipt of interest from investments. $\sum_{i \neq j} b_{ij}$ represents the increase in cash, per unit time, due to borrowings from others banks and $-\sum_{i \neq j} h_{ij} B_{ij}$ is the reduction in cash due to the payment of interests to lending banks. $-\sum_{i \neq j} l_{ij}$ represents the reduction in cash, per unit time, due to loans to other banks and $\sum_{i \neq j} k_{ij} L_{ij}$ is the increase of cash due to the receipt of interest from borrowing banks. g_i , p_i , h_{ij} and k_{ij} represent interest rates. Importantly, when C_i becomes negative, bank i fails and is removed from the system.

Deposits

The deposits, D_i , are assumed to be assigned by an exogenous signal. Following Iori et al., the deposit signal for each bank at time t is set as:

$$D_i = |\bar{D} + \bar{D} \sigma_D \varepsilon_t| \quad (2)$$

Eq.2 models the case in which fluctuations (shocks) in the deposit are caused by random but mutually uncorrelated payments/withdrawals of deposits. \bar{D} represents an average size of the deposits; in the homogeneous case, \bar{D} is the same for each bank, while in the heterogeneous case different values of \bar{D} are assigned to the banks by sampling from a Gaussian distribution. σ_D represents the amplitude of the shocks, while ε_t is a random variable ($\varepsilon_t \sim N(0,1)$). In this paper, only results of the homogeneous case (i.e. banks have similar sizes) will be presented.

Investments

Eq.3 below describes the investment behaviour of bank i ; each bank makes its investment at time t depending on two factors: one is the availability of cash above the value required by the reserve ratio, $(C_i - rD_i)^+$; where $(x)^+$ stands for $\max\{x, 0\}$. r is the reserve ratio that is the portion of the total deposit that banks must have on hand as cash. The second factor is the stochastic investment opportunity at time t , opp_i ; this is described in Eq.4 where $\overline{opp} = \delta\bar{D}$ (with $1 < \delta < 0$ and $\eta_t \sim N(0,1)$), which means that the investment opportunity is affected by the size of the bank. Therefore, taking these two factors into consideration, a bank invests only when it has money, as well as opportunity.

$$\frac{dI_i}{dt} = \min[(C_i - rD_i)^+, opp_i] - wI_i - vI_i \quad (3)$$

$$opp_i = |\overline{opp} + \sigma_{opp}\eta_t| \quad (4)$$

In eq. 3, $-wI_i$ represents the proportion of total investment, per unit time, that has matured. $-vI_i$ represents the proportion of total investments that has been lost, per unit time, due to defaults. It must be stressed that $\min[(C_i - r * D_i)^+, opp_i]$ is intended to be the amount of money invested per unit time.

Interbank borrowing and lending

To build the interconnection between banks, borrowing and lending activities are introduced into the model. Due to fluctuations in deposits, the cash of any given bank may become less than the required amount dictated by the reserve ratio. In this case that bank will need to borrow money from other banks. Eq.5 shows the change per unit time of borrowing/lending between two banks. Bank i borrows just enough to meet the reserve ratio requirements. Bank j will only lend cash that is above its required reserve.

$$db_{ij} = dl_{ji} = \min[(rD_i - C_i)^+, (C_j - rD_j)^+] \quad (5)$$

$$\frac{dB_{ij}}{dt} = b_{ij} + \sigma_{ij}B_{ij}\alpha_{ij} \quad (6)$$

Eq. 6 shows how the total borrowing is updated. The first term in the right-hand-side of the equation is the change in borrowing previously explained. The second term is the proportion (α_{ij}) of the total borrowing repaid, per unit time, by bank i to bank j at the current time step. σ_{ij} represents the link between bank i and bank j . σ_{ij} can be 0, which means that there is no link between the two banks, or 1, which means that the two bank are connected and can exchange money. All the σ_{ij} are generated at the beginning of the simulation according to the choice of the link rate, l_r , which can get values from 0 to 1 and represents the degree of connectivity of the system. The closer the link rate to 1, the more connected the system will be.

Interest rates

In our model the interest rates for borrowing and lending, h_{ij} and k_{ji} , change with time according to the following equation :

$$h_{ij} = k_{ji} = h_0 + \frac{a}{e^{\left(y - \frac{B_{ij}}{C_j}\right)z} + 1} \quad (7)$$

In Eq.7, h_0 is the basic interest rate applied for lending and borrowing. The term, $\frac{a}{e^{\left(y - \frac{B_{ij}}{C_j}\right)z} + 1}$, is the extra interest, which is charged depending on the health of both borrowing and lending banks. When $\frac{B_{ij}}{C_j} = 0$, the interest rate is close to h_0 . When $\frac{B_{ij}}{C_j} = y$, the rate becomes $h_{ij} = h_0 + \frac{a}{2}$. When $\frac{B_{ij}}{C_j} \rightarrow +\infty$, the rate becomes $h_{ij} = h_0 + a$, which is the maximum value possible. In Eq. 7, z is the speed of transition between the states $h_{ij} = h_0 + \frac{a}{2}$ and $h_{ij} = h_0 + a$. Once the interest rates are set, the interbank borrowing and lending process works as follows: the bank with greatest net worth can first choose the bank to borrow money from. The borrowing bank will choose the bank with the lowest lending interest rate and if the available funds are not enough it will move to the bank with the second lowest lending rate. When the first bank has finished borrowing, the bank with the second greatest net worth starts to borrow according to the same rule.

Simulation of the model

Figure 3 shows the flowchart of the model illustrating how the banks' activities take place during each step of the computer simulation. At the beginning of the step, the banks' cash changes due to interest payments to depositors and changes of deposits due to stochastic shocks. If the cash of a bank falls below the value required by the reserve ratio that bank has to borrow from other banks. After this step, each bank repays creditors in cash. Those banks that cannot meet the repayment obligations will need to borrow from other banks. Banks that still have extra cash will invest. Those banks that are left with negative cash, as they could not borrow enough cash, are deemed to be in default. These banks are removed from the system. Their remaining assets are distributed to depositors and to lending banks. After any default liquidation a new simulation step will start. At the end of the simulation, i.e. after a chosen number of steps, the banks that survived are counted and other relevant quantities are calculated.

3. Preliminary results

This section shows the simulation results generated by the model described in Section 2. It is implemented using Matlab and Simulink, which is a powerful design tool frequently used for control design and analysis. The number of banks in the system at the beginning of simulations is 50. This number of banks is sufficient to exhibit rich dynamics. The unit time is one day and the total simulation time is 1000 days. The results are analysed here for only the homogenous case, in which all banks have a similar size; shocks are introduced into the system via deposit fluctuations. Simulations with different values for link rate and reserve ratio, representing different scenarios, are run and the number of surviving banks is calculated.

The chosen values for the parameters in Eq. 2 are $\bar{D} = 1000$ and $\sigma_D = 0.3-0.5$, which are similar to the values used in Iori's work (Iori et al., 2006). The values of the link rate, l_r , are 0, 0.3, 0.5, 0.8 and 1. The reserve ratio, r , values are taken as 0.1, 0.2, 0.4 and 0.7 in this study. So there are thus 40 different combinations in total, corresponding to 40 different scenarios/simulations.

Figure 4 shows how the number of surviving banks is affected by different reserve ratios when the link rate, l_r , is fixed, and $\sigma_D = 0.3$. Figure 4(a) reports the results corresponding to $l_r = 0$; this figure shows that when there is no interbank lending, the reserve ratio definitely plays a positive role to preserve the stability of the system. In fact, as the reserve ratio increases, more banks survive at the end of the simulation period. This trend is present also when the link rate increases as shown in Figure 4 (b) (c) and (d); from these figures it can be seen that with a higher link rate the number of surviving banks increases. However, when the amplitude of the shocks, σ_D , is increased to 0.5 as in Figure 7, the effect of the reserve ratio is different. Figure 5(a), for which $l_r = 0$, all the banks will fail very quickly (at day 60), which means the banks cannot buffer large shocks on the deposits by only holding the required reserve. However, when the link rate increases to 0.3, 0.8 and 1 as Figure 5(b), (c) and (d), bank failure is slower. Interestingly, an increase in the reserve ratio causes more banks to fail which may appear counterintuitive. The explanation is as follows: high reserve ratios discourage banks from lending, which is a problem when some banks experience high negative shocks in their deposits.

Figure 6 shows the effect of the link rate on the number of surviving banks, when the reserve ratio is fixed. In Figure 8(a) ($r = 0.1$), more banks survive as the link rate increases. Figures 6(b) and (c), corresponding to higher reserve ratios, show similar trends. In Figure 6 (d), in which the reserve ratio is 0.7, as the link rate increases from 0 to 0.3, more banks survive. However, with further increases of the link rate only a few additional banks survive. This indicates that, when the reserve ratio is high, the increase in the link rate does not help improving any further the stability of the system. The trends shown in Figures 4, 5 and 6 can be observed also in Figure 7, which reports a waterfall plot of the number of surviving banks at day 1000 as a function of both link rate and reserve ratio.

Another important way to analyse how reserve ratio and link rate affect the stability of the system is to see how the two quantities affect the time at which failure occurs. More specifically, during each simulation we recorded the times at which the first and the second bank failure happen for different values of reserve ratio and link rate. Preliminary results are reported in figure 8 and 9. In Figure 8, the first and the second failure times have been reported as function of the reserve ratio, at fixed values of the link rate and for two different values of the amplitude of the shock ($\sigma_D = 0.3$ and 0.5). From the two subplots in the first column, when $l_r = 0$, the increase of the reserve ratio does not delay the first default time. But as the link rate increases, low reserve ratios seem to perform better than the high reserve ratios in postponing the default occurrence. Since high reserve ratios force the banks to keep more cash, this inhibits interbank borrowing. In Figure 9, the first and the second failure times have been reported as function of the link rate, at fixed values of the reserve ratio and for two different values of the amplitude of the shock ($\sigma_D = 0.3$ and 0.5). In the last column when reserve ratio is 0.7, no changes are observed when the link rate changes. As the reserve ratio decreases, instead, a high link rate will make the first or second default time occur later; this seems to suggest that the link rate has a positive role for the bank's stability when the reserve ratio is not high.

Another interesting aspect of the model is the analysis of the effect of contagion through the interbank borrowing and lending. In this paper, the effect of contagion is quantified in the following way: when a bank fails, the model verifies whether that bank has unpaid loans from the banks that failed earlier. At the end of the simulation, the proportion of failed banks with unpaid loans, as compared to the total number of failed banks, is calculated; the higher this proportion, the higher the effect of contagion. Figure 10(a) reports the proportion of failed banks with unpaid loans as a function of both link rate and reserve ratio, for $\sigma_D = 0.3$. When the link rate is below 0.4, the reserve ratio seems not to affect contagion significantly. When the link rate is above 0.4, the increase in reserve ratio seems to favour contagion. A possible explanation for this is that since banks need to keep enough cash to reach the required reserve ratio, they have to borrow money. This increases the interbank activities and enhances opportunities for contagion. In figure 10(b),

reports the results for contagion, when $\sigma_D = 0.5$. In this case, when the link rate is above 0.4, the increase in reserve ratio seems to reduce the occurrence of contagion, which is the opposite of what shown in figure 10(a). More work needs to be done to analyse this behaviour in more detail.

4. Conclusion and further work

The dynamic model presented in this paper allows the study of the stability of the modelled banking system as a function of different quantities, such as link rate, reserve ratio and the amplitude of deposit shocks. The results show that for moderate shocks, both reserve ratio and link rate have a positive effect on the stability of the system. However, for high values of shock, high reserve ratios may have a detrimental effect on the survival of banks. The model also allows the quantification of contagion, and it shows how this is affected by the reserve ratio and link rate. An important further work is to formally apply control-theory which will permit a greater range of scenarios to be considered.

References

- Acemoglu, D., Ozdaglar, A., Tahbaz-Salehi, A., 2015. Networks, Shocks, and Systemic Risk (Working Paper No. 20931). National Bureau of Economic Research.
- Acharya, V., Engle, R., Richardson, M., 2012. Capital Shortfall: A New Approach to Ranking and Regulating Systemic Risks. *Am. Econ. Rev.* 102, 59–64. doi:10.1257/aer.102.3.59
- Acharya, V.V., Pedersen, L.H., Philippon, T., Richardson, M., 2010. Measuring systemic risk (Working Paper No. 1002). Federal Reserve Bank of Cleveland.
- Andrew Haldane, 2012. From individual players to an interconnected system Number 9, 7–8.
- Basel III: a global regulatory framework for more resilient banks and banking systems [WWW Document], 2011.
- Benoit, S., Colletaz, G., Hurlin, C., Perignon, C., 2013. A Theoretical and Empirical Comparison of Systemic Risk Measures (SSRN Scholarly Paper No. ID 1973950). Social Science Research Network, Rochester, NY.
- Brownlees, C.T., Engle, R., 2010. Volatility, Correlation and Tails for Systemic Risk Measurement, Working Paper Series.
- Davies, R., Richardson, P., Katinaite, V., Manning, M.J., 2010. Evolution of the UK Banking System (SSRN Scholarly Paper No. ID 1730160). Social Science Research Network, Rochester, NY.
- Eugenio Cerutti et al., 2015. An Overview of Macroprudential Policy Tools (Working Paper No. 15/61). IMF.
- Fleming, W., Pang, T., 2004. An Application of Stochastic Control Theory to Financial Economics. *SIAM J. Control Optim.* 43, 502–531. doi:10.1137/S0363012902419060
- F. S. Board, 2011. Policy Measures to Address Systemically Important Financial Institutions.
- Galati, G., Moessner, R., 2013. Macroprudential Policy – a Literature Review. *J. Econ. Surv.* 27, 846–878. doi:10.1111/j.1467-6419.2012.00729.x
- Greenwood, R., Landier, A., Thesmar, D., 2012. Vulnerable Banks (Working Paper No. 18537). National Bureau of Economic Research.
- Haldane, A.G., May, R.M., 2011. Systemic risk in banking ecosystems. *Nature* 469, 351–355. doi:10.1038/nature09659
- Iori, G., Jafarey, S., Padilla, F.G., 2006. Systemic risk on the interbank market. *J. Econ. Behav. Organ.* 61, 525–542. doi:10.1016/j.jebo.2004.07.018
- John Kay, 2012. Understanding the bigger picture. *FST J.* Number 9, 5–6.
- Kaas, L., 1998. Stabilizing chaos in a dynamic macroeconomic model. *J. Econ. Behav. Organ.*, Papers presented at the fifth Viennese workshop on advances in nonlinear economic dynamics 33, 313–332. doi:10.1016/S0167-2681(97)00061-9
- Kamien, M.I., Schwartz, N.L., 1991. *Dynamic Optimization: The Calculus of Variations and Optimal Control in Economics and Management*, 2nd edition. ed. Elsevier Science, Amsterdam ; New York : New York, N.Y.
- Kendrick, D., 1976. *Applications of Control Theory to Macroeconomics (NBER Chapters)*. National Bureau of Economic Research, Inc.
- Kern, S., 2012. Macro-prudential financial supervision in the US-The Financial Stability Oversight Council (FSOC). *Dtsch. Bnak Res.*
- Malik, S.A., 1998. *Multivariable feedback control analysis and design*, S. Skogestad and I. Postlethwaite, Wiley, Chichester, U.K., ISBN 0-471-94277-4, xi+559 pp., 1996. *Int. J. Robust Nonlinear Control* 8, 1237–1238. doi:10.1002/(SICI)1099-1239(19981215)8:14<1237::AID-RNC377>3.0.CO;2-7
- May, R.M., Arinaminpathy, N., 2010. Systemic risk: the dynamics of model banking systems. *J. R. Soc. Interface* 7, 823–838. doi:10.1098/rsif.2009.0359
- Nier, E., Yang, J., Yorulmazer, T., Alentorn, A., 2007. Network models and financial stability. *J. Econ. Dyn. Control*, Tenth Workshop on Economic Heterogeneous Interacting Agents WEHIA 2005 31, 2033–2060. doi:10.1016/j.jedc.2007.01.014

- Pham, H., 2009. *Continuous-time Stochastic Control and Optimization with Financial Applications*, 1st ed. Springer Publishing Company, Incorporated.
- Yan, X.-G., Edwards, C., 2007. Nonlinear robust fault reconstruction and estimation using a sliding mode observer. *Automatica* 43, 1605–1614. doi:10.1016/j.automatica.2007.02.008
- Yan, X.-G., Edwards, C., Spurgeon, S.K., 2004. Output feedback sliding mode control for nonminimum phase systems with nonlinear disturbances, in: *Control Conference, 2004. 5th Asian*. Presented at the Control Conference, 2004. 5th Asian, pp. 1951–1957 Vol.3.
- Yan, X.-G., Spurgeon, S.K., Edwards, C., 2005. Dynamic Sliding Mode Control for a Class of Systems with Mismatched Uncertainty. *Eur. J. Control* 11, 1–10. doi:10.3166/ejc.11.1-10
- Yan, X.-G., Spurgeon, S.K., Zhu, Q., Zhang, Q., 2013. Delay independent static output feedback variable structure control for affine nonlinear systems, in: *Control Conference (ECC), 2013 European*. Presented at the Control Conference (ECC), 2013 European, pp. 179–184.

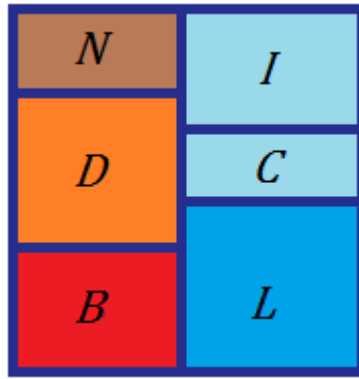

Figure 1. Bank's activities used in the model: N =net-worth, D =deposits, B =interbank borrowings, L =interbank loans, C =cash and I =investment.

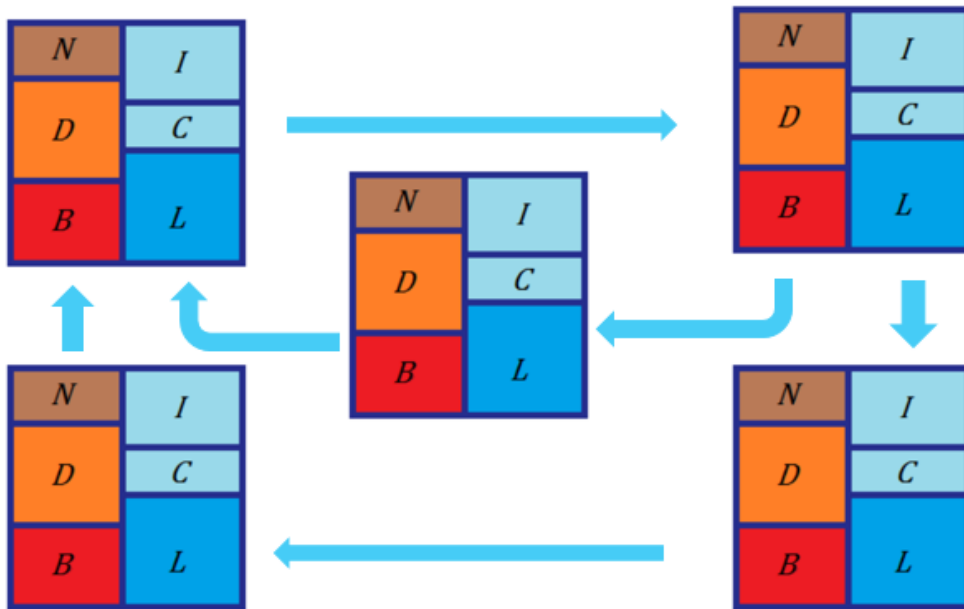

Figure 2. Links between banks forming the network: the links between banks are made by the loans/borrowings.

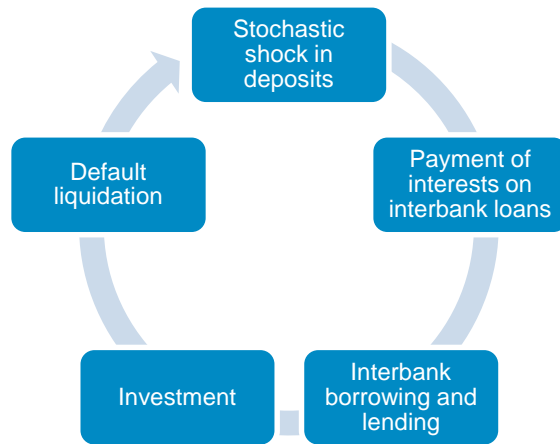

Figure 3. Flowchart showing activities taking place during one simulation step.

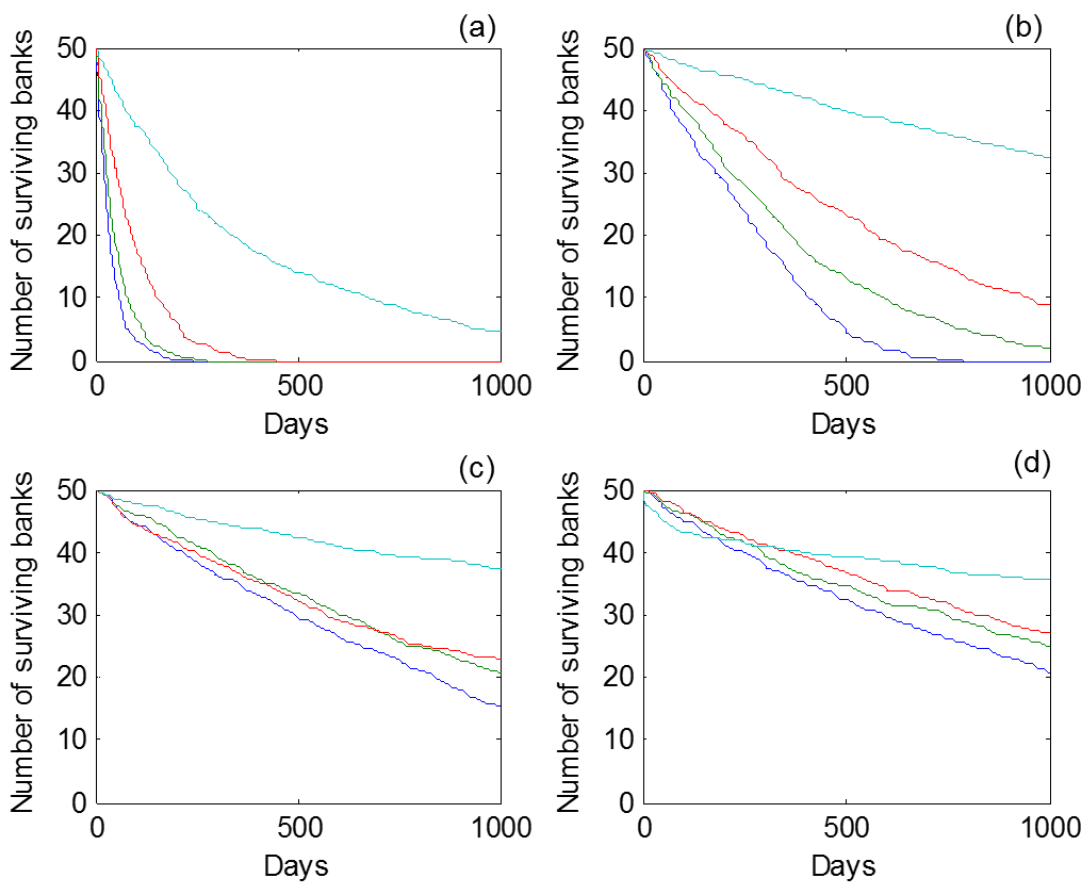

Figure 4. Number of surviving banks with $\sigma_D = 0.3$, $\sigma_{opp} = 0.5$ and different reserve ratios: $r=0.1$ (dark blue line), $r=0.2$ (dark green line), $r=0.4$ (red line), $r=0.7$ (light blue line), under different link rates, $l_r=0$ (a), $l_r=0.3$ (b), $l_r=0.8$ (c), $l_r=1$ (d).

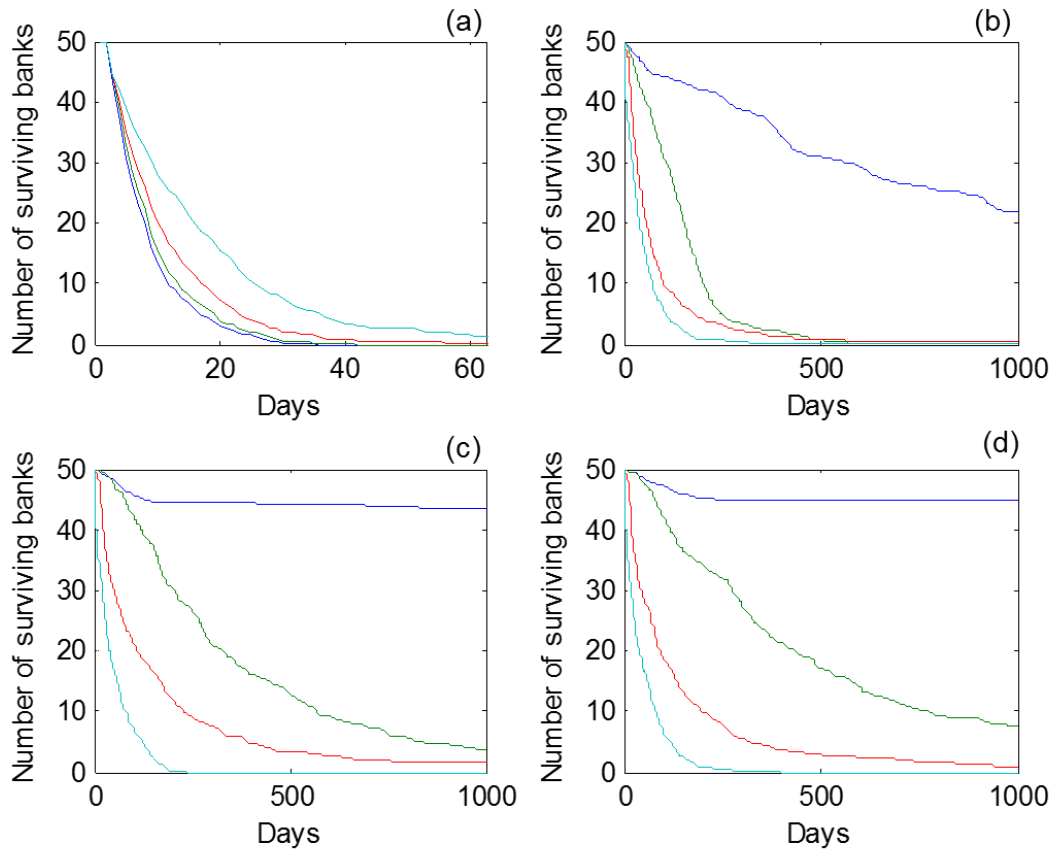

Figure 5. Number of surviving banks with $\sigma_D = 0.5$, $\sigma_{opp} = 0.5$ and different reserve ratios: $r=0.1$ (dark blue line), $r=0.2$ (dark green line), $r=0.4$ (red line), $r=0.7$ (light blue line), under different link rates, $l_r=0$ (a), $l_r=0.3$ (b), $l_r=0.8$ (c), $l_r=1$ (d).

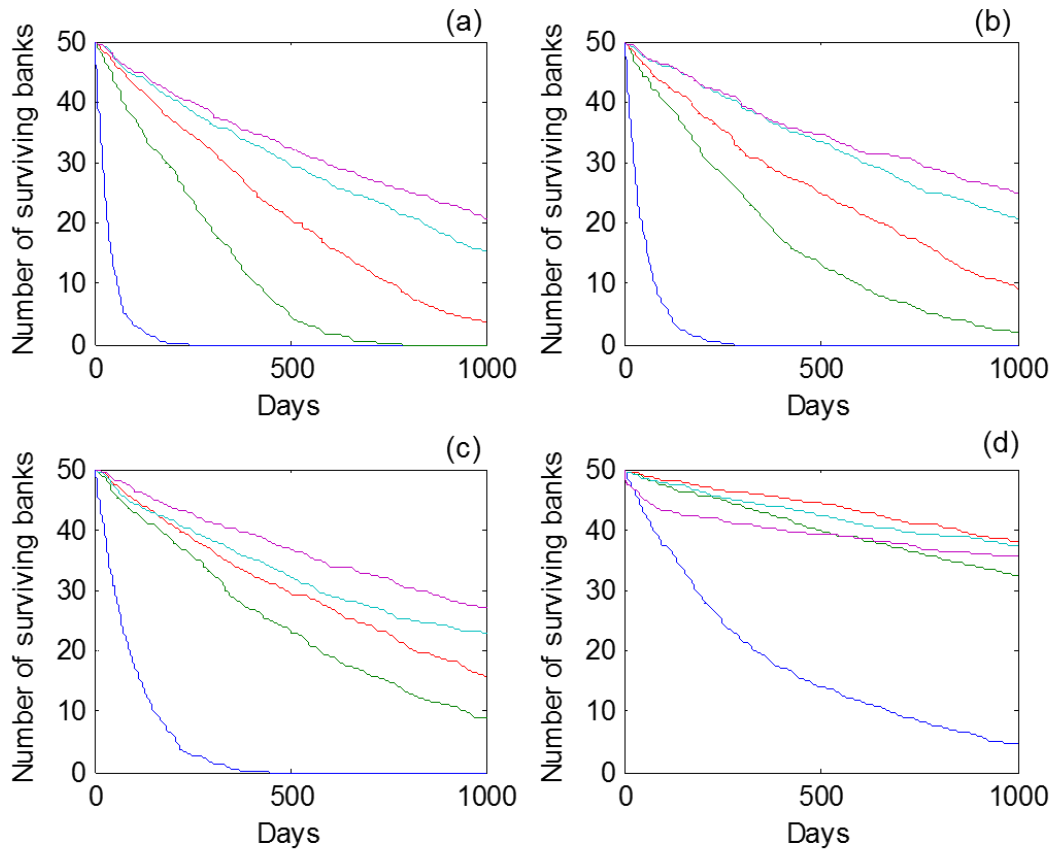

Figure 6. Number of surviving banks with $\sigma_D = 0.3$, $\sigma_{opp} = 0.5$, and different link rates, $l_r = 0$ (dark blue line), $l_r = 0.3$ (green line), $l_r = 0.5$ (red line), $l_r = 0.8$ (light blue line), $l_r = 1$ (purple line) under different reserve ratios $r=0.1$ (a), $r=0.2$ (b), $r=0.4$ (c), $r=0.7$ (d).

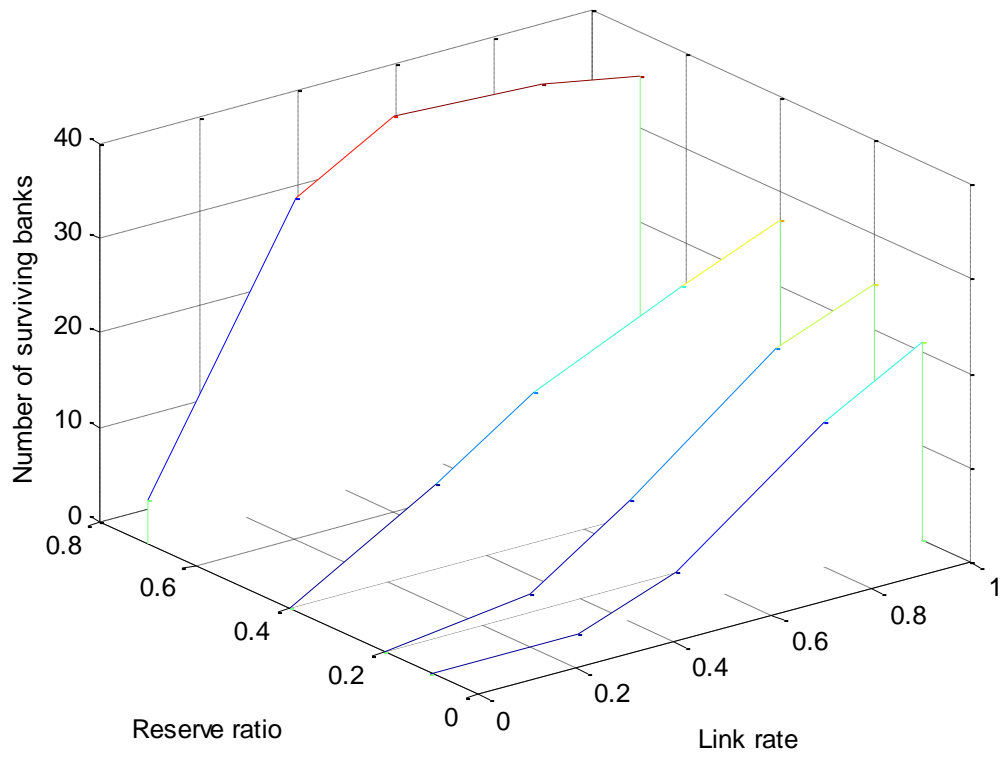

Figure 7. Waterfall plot showing the number of surviving banks at day 1000 as function of both link rate and reserve ratio.

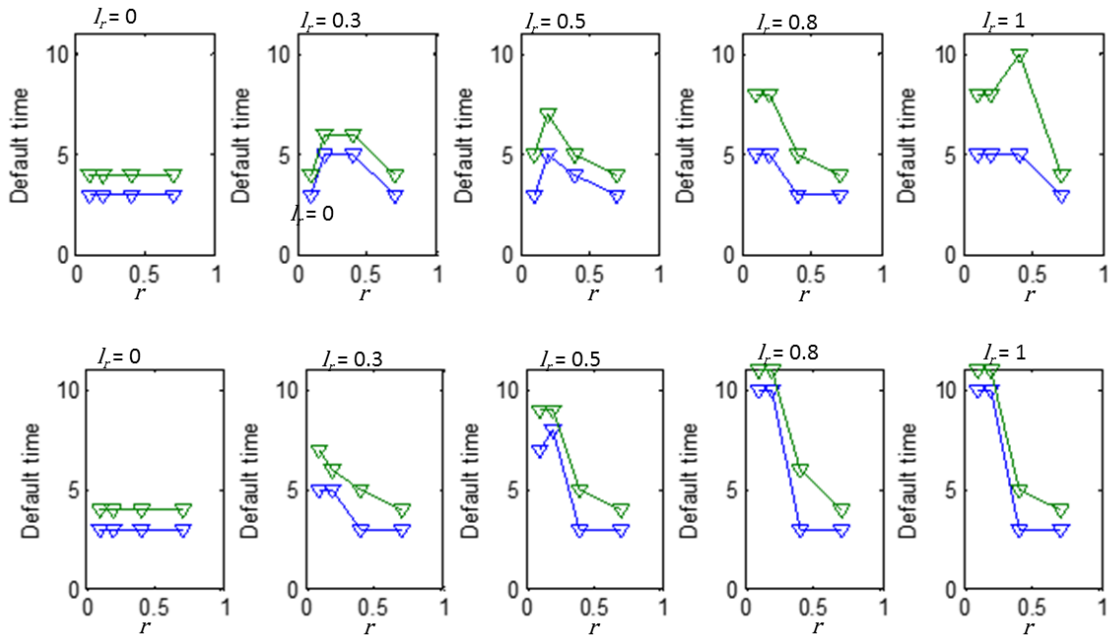

Figure 8. First (blue line) and second (green line) time of failure as function of reserve ratio, at fixed link rate and amplitudes of the shocks ($\sigma_D = 0.3$, first row, and $\sigma_D = 0.5$, second row).

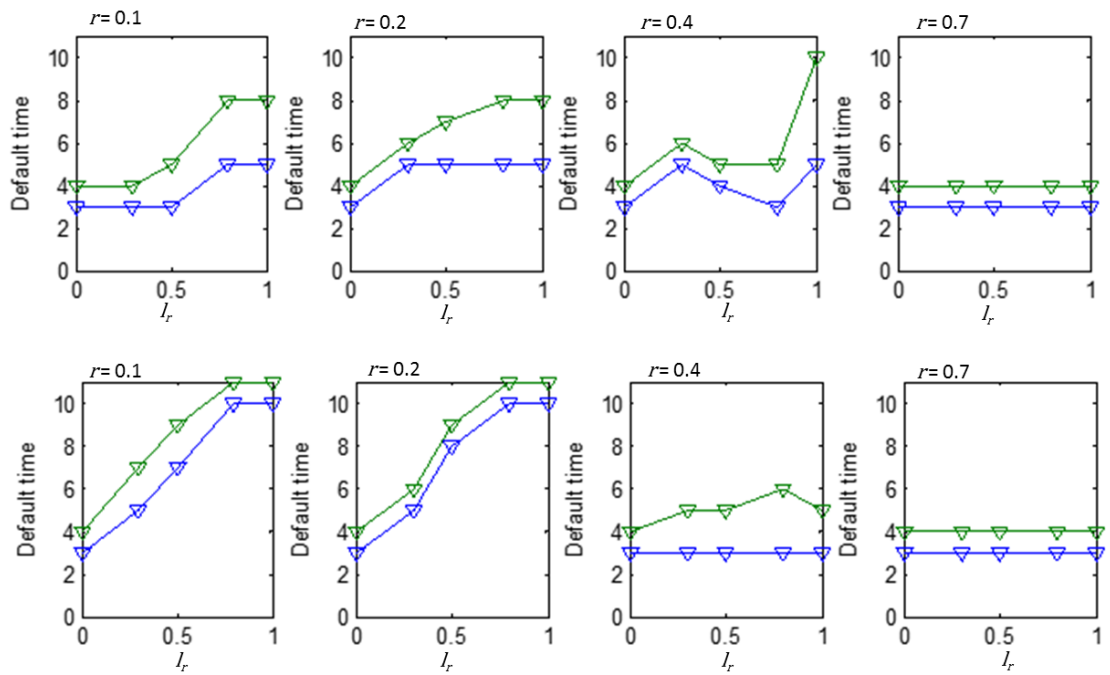

Figure 9. First (blue line) and second (green line) time of failure as function of link rate, at fixed reserve ratio and amplitudes of the shocks ($\sigma_D = 0.3$, first row, and $\sigma_D = 0.5$, second row).

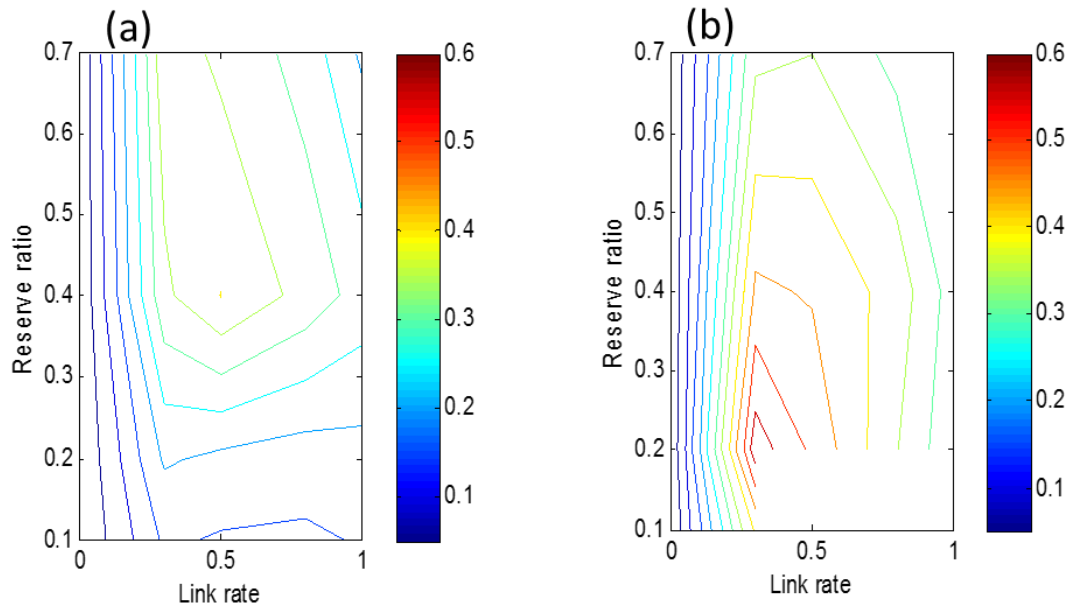

Figure 10. Coutour plot reporting the proportion (in different colours) of failed banks with unpaid loans as function of link rate and reserve ratios, at day 1000 and $\sigma_D = 0.3$ (a), $\sigma_D = 0.5$ (b).