

# $H_{\infty}$ and $\mu$ -synthesis Design of Quarter Car Active Suspension System

Mustefa Jibril\*, Tesfabirhan Shoga\*\*

\*(Department of Electrical & Computer Engineering, DireDawa Institute of Technology, DireDawa, Ethiopia

Email: [mustefazinet1981@gmail.com](mailto:mustefazinet1981@gmail.com)

\*\* (Department of Electrical & Computer Engineering, Jimma Institute of Technology, Jimma, Ethiopia

Email: [birhanetesfa@gmail.com](mailto:birhanetesfa@gmail.com)

\*\*\*\*\*

## Abstract:

To improve the street managing and passenger comfort of a vehicle, a suspension system is furnished. An active suspension device is considered to be better than the passive suspension device. In this paper, 2 degree of freedom of an active suspension system of a linear vehicle are designed, that's challenge to one-of-a-kind disturbances on the road. Since the parametric uncertainty inside the spring, the shock absorber, the mass and the actuator has been taken into consideration, robust control is used. In this paper,  $H_{\infty}$  and  $\mu$ -synthesis controllers are used to enhance using consolation and the capability to force the car on the road. For the analysis of the time domain, a MATLAB script software become used and a check with 4 road disturbance inputs (bump, random, sinusoidal and harmonic) became carried out for suspension deflection, body acceleration and travel of the body for the energetic suspension with the  $H_{\infty}$  controller and the active suspension with the  $\mu$ -synthesis controller and the comparative simulation and the reference consequences display the effectiveness of the active suspension system with the  $\mu$ -synthesis controller.

**Keywords** —Quarter car active suspension system,  $H_{\infty}$  controller,  $\mu$  - synthesis controller, Robust controller

\*\*\*\*\*

## I. INTRODUCTION

At present, the arena's main automotive agencies and research institutions have invested massive human and cloth assets to develop a value-effective car suspension machine, to be widely used in the vehicle. The fundamental purpose of the suspension system is to isolate the automobile body from the irregularities of the road to maximize passenger comfort and retain non-stop avenue wheel contact to offer avenue grip. Many studies have shown that vibrations because of abnormal road surfaces have an impact of energy draining in drivers, which influences their physical and intellectual health [1]. The needs for extra driving consolation and

manipulate potential of avenue vehicles, together with motors, have motivated the development of recent kinds of suspension systems, along with lively and semi-active suspension systems. These electronically controlled suspension systems can potentially improve using comfort, in addition to driving the car on the street. An active suspension device has the ability to continuously modify to changing avenue conditions. By changing its individual to respond to variable road conditions, the lively suspension gives advanced coping with, street sense, responsiveness and safety.

An active suspension system has the ability to continuously adjust to changing road conditions. By changing its character to respond to different road

conditions, the active suspension offers superior handling, road feel, responsiveness and safety. Active suspension structures reply dynamically to adjustments in the street profile because of their capacity to supply energy that can be used to produce relative motion among the frame and the wheel. Typically, active suspension systems consist of sensors to degree suspension variables, which include body velocity, suspension displacement and wheel speed, and wheel and frame acceleration. An energetic suspension is one in which the passive components are augmented through actuators that provide additional forces. These extra forces are determined via a feedback manage regulation that makes use of sensor statistics connected to the vehicle.

The present energetic suspension system is inefficient if there are changes in the system or actuator parameters, then controlling the suspension machine will become a huge trouble. Therefore,  $H_\infty$  and  $\mu$ -synthesis control strategies are used.  $H_\infty$  and  $\mu$ -synthesis manage successfully suppresses vehicle vibrations in the touchy frequency variety of the human frame. The preferred sturdy performance and robust stability are performed inside the closed circuit machine for a vehicle room model inside the presence of dependent uncertainties.

## II. MATHEMATICAL MODEL

### A. Active Suspension System Mathematical Model

The mathematical model of the subsequent subsection best analyzes the amount of pressure created through the active suspension. Active suspensions permit the fashion designer to stability those objectives the usage of a hydraulic actuator that is pushed via a motor among the chassis and the wheel meeting. The actuator force  $f_s$  applied among the body and the wheel assembly represents the active aspect of the suspension system.

Most researchers choose the dynamic surprise model of the carrier system when they consciousness on the vertical vibration of the automobile frame caused by the roughness of the pavement. Although the dynamic vibration placing of the car has now not included all the geometric

facts of the car, it can't inspect the effect of the vehicle's perspective of inclination and the vibration of the rolling angle.

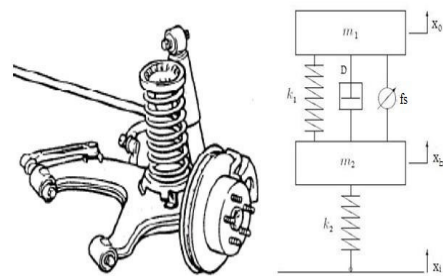

Figure 1: Quarter model of active suspension system with actuating force  $f_s$  between sprung and unsprung mass.

Figure 1 indicates a car quarter model of the active suspension system. The mass  $m_1$  (in kilograms) represents the car chassis (frame) and the mass  $m_2$  (in kilograms) represents the wheel assembly. The spring  $K_1$  and the surprise absorber  $D$  constitute the passive spring and the surprise absorber positioned between the automobile frame and the wheel meeting. The  $K_2$  spring fashions the compressibility of the tire. The variables  $x_0$ ,  $x_b$  and  $x_i$  (all in meters) are the body travel, wheel travel, and road disturbance, respectively. The actuator pressure  $f_s$  (in kiloNewton's) implemented among the body and the wheel assembly is controlled via remarks and represents the active issue of the suspension system. From this model, we are able to examine the dynamics of the car suspension system as a linear system version and establish two degree of freedom. The differential equations of motion could be as follows:

$$m_1 \ddot{x}_0(t) + D[\dot{x}_0(t) - \dot{x}_2(t)] + k_1[x_0(t) - x_2(t)] = u \quad (1)$$

$$m_2 \ddot{x}_2(t) - D[\dot{x}_0(t) - \dot{x}_2(t)] + k_1[x_2(t) - x_0(t)] + k_2[x_2(t) - x_i(t)] = -u \quad (2)$$

We can set:

$$x_1 = x_2(t), x_2 = x_0(t), x_3 = \dot{x}_2(t), x_4 = \dot{x}_0(t)$$

The system state space equation can be express as:

$$\frac{dX}{dt} = AX + BU$$

In this equation, state variable matrixes are:

$$X = (x_1 \quad x_2 \quad x_3 \quad x_4)^T$$

Constant matrixes A and B are shown as below:

$$A = \begin{pmatrix} 0 & 0 & 1 & 0 \\ 0 & 0 & 0 & 1 \\ -\frac{k_1+k_2}{m_2} & \frac{k_1}{m_2} & -\frac{D}{m_2} & \frac{D}{m_2} \\ \frac{k_1}{m_1} & -\frac{k_1}{m_1} & \frac{D}{m_1} & -\frac{D}{m_1} \end{pmatrix}$$

$$B = \begin{pmatrix} 0 & 0 \\ 0 & 0 \\ \frac{k_2}{m_2} & \frac{1}{m_2} \\ 0 & -\frac{1}{m_1} \end{pmatrix}$$

The system input variable matrix will be:

$$U = (x_1(t) \quad u)^T$$

The vehicle suspension system output matrix equation will be:

$$Y = CX + DU$$

In above equation, the output variable matrix Y will be:

$$Y = (k_2 [x_1(t) - x_2(t)] \quad \ddot{x}_0(t) \quad x_0(t))$$

Y will also express as the following equation:

$$Y = (k_2 [x_1(t) - x_2(t)] \quad \ddot{x}_0(t) \quad x_0(t))$$

Constant matrixes C and D will be shown as below:

$$C = \begin{pmatrix} -k_2 & 0 & 0 & 0 \\ \frac{k_1}{m_1} & -\frac{k_1}{m_1} & \frac{D}{m_1} & -\frac{D}{m_1} \\ 0 & 1 & 0 & 0 \end{pmatrix}$$

$$D = \begin{pmatrix} k_2 & 0 \\ 0 & -\frac{1}{m_1} \\ 0 & 0 \end{pmatrix}$$

**B. Hydraulic Actuator System Mathematical Model**

The hydraulic actuator consists of a variable stroke hydraulic pump and a hard and fast stroke hydraulic motor as proven in Figure 2 underneath. The tool accepts a linear displacement input (stroke period)

and offers angular displacement. The pump and the motor are linked to the wheel meeting and this arrangement is hooked up to the car chassis via a metallic chain. When a sudden displacement of a road disturbance enters the pump, high pressure oil will enter the engine and the engine will control the displacement between the wheel assembly and the automobile chassis.

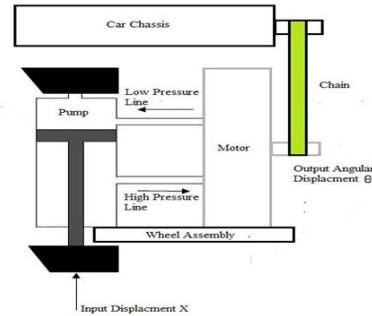

Figure 2: Hydraulic actuator block diagram

The hydraulic motor is controlled by using the quantity of oil delivered via the pump. By automatically converting the pump stroke, the oil brought by the pump is managed. As with a DC generator and a DC motor, there's no essential difference among the hydraulic pump and the motor. In a pump, the input is mechanical energy and the output is hydraulic energy, and in an engine, it's far the other way round.

Let

- $q_p$  Rate at which pump oil flows
- $q_m$  Oil go with the flow thru the motor
- $q$  Leakage flow rate
- $q_c$  Compressibility flow
- $x$  Input stroke length
- $\theta$  Angular displacement of motor output
- $P$  Pressure drop throughout the motor

The rate at which the pump oil glide is proportional to the running speed, that is, i.e.  $q_p \propto \frac{dx}{dt}$ .

Oil waft from the pump,

$$q_p = K_p \frac{dx}{dt} \quad (3)$$

Where

$K_p$  = Relationship between oil waft charge and unit stroke attitude..

The oil go with the flow fee thru the motor is proportional to the motorspeed, this is., i.e.

$$q_m \propto \frac{d\theta}{dt} \dots$$

Oil glide via the motor,

$$q_m = K_m \frac{d\theta}{dt} \quad (4)$$

Where

$K_m$  = Motor displacement constant.

All pump oil does no longer go with the flow thru the motor within the right channels. Due to the back strain in the motor, a cut inside the way that flows from the pump escapes beyond the engine and pump pistons. The back strain is the importance generated by using the hydraulic flow to overcome the hostility of the free motion supplied by the burden on the motor shaft.

It is usually assumed that the leakage go with the flow is proportional to the engine strain, that is, i.e.  $q_i \propto P$ .

Leakage flow rate,

$$q_i = K_i P \quad (5)$$

Where

$K_i$  = constant.

The returned stress accrued with the aid of the motor now not best causes the engine and pump to leak, however also the oil in the lines is compressed. The quantity compressibility flow is essentially proportional to the strain and, consequently, the float rate is proportional to the strain innovation

rate, i.e.  $q_c \propto \frac{dP}{dt}$

Compressibility flow rate,

$$q_c = K_c \frac{dP}{dt} \quad (6)$$

Where

$K_c$  = Coefficient of compressibility.

The rate at which the oil flows from the pump is given by using the sum of the oil go with the flow fee thru the motor, the leakage fee and the compressibility flow rate.

$$q_p = q_m + q_i + q_c$$

Substituting eqn. (3), (4), (5) and (6) from above equations, we get

$$K_p \frac{dx}{dt} = K_m \frac{d\theta}{dt} + K_i P + K_c \frac{dP}{dt} \quad (7)$$

The torque  $T_m$  developed through the motor is proportional to the stress drop and balances the load torque.

$$T_m = K_t P \quad (8)$$

Where

$K_t$  is motor torque constant.

If the load is meant to include a moment of inertia  $J$  and viscous friction with coefficient  $B$ ,

Then

Load Torque

$$T_l = J \frac{d^2\theta}{dt^2} + B \frac{d\theta}{dt} \quad (9)$$

Hydraulic power input

$$= q_m P \quad (10)$$

Substituting eqn. (4) into eqn. (10), we get

$$\text{Hydraulic power input} = K_m \frac{d\theta}{dt} P \quad (11)$$

$$\text{Mechanical power output} = T_m \frac{d\theta}{dt} \quad (12)$$

Substituting eqn. (8) into eqn. (12), we get

$$\text{Mechanical power output} = K_t P \frac{d\theta}{dt} \quad (13)$$

If hydraulic motor losses are neglected or covered as a part of the load, then the hydraulic motor enter is equal to the mechanical strength of the hydraulic motor.

$$K_m \frac{d\theta}{dt} P = K_t P \frac{d\theta}{dt} \quad (14)$$

From equation (14), it is clear that  $K_m = K_t$ .

Hence we can write

$$T_m = K_t P = K_m P$$

Since the motor torque equals load torque,  $T_m = T_l$

$$K_m P = J \frac{d^2\theta}{dt^2} + B \frac{d\theta}{dt} \quad (15)$$

$$P = \frac{J}{K_m} \frac{d^2\theta}{dt^2} + \frac{B}{K_m} \frac{d\theta}{dt} \quad (16)$$

Differentiating equation (16) w.r.t time, we get

$$\frac{dP}{dt} = \frac{J}{K_m} \frac{d^3\theta}{dt^3} + \frac{B}{K_m} \frac{d^2\theta}{dt^2} \quad (17)$$

Substituting for P and dP/dt to eqn.(7), we get,

$$K_p \frac{dx}{dt} = K_m \frac{d\theta}{dt} + K_i \left[ \frac{J}{K_m} \frac{d^2\theta}{dt^2} + \frac{B}{K_m} \frac{d\theta}{dt} \right] + K_c \left[ \frac{J}{K_m} \frac{d^3\theta}{dt^3} + \frac{B}{K_m} \frac{d^2\theta}{dt^2} \right] \quad (18)$$

Taking Laplace transform with zero initial conditions, we get,

$$\frac{\theta(s)}{X(s)} = \frac{K_p}{\left[ \frac{K_c J}{K_m} s^2 + \left[ \frac{K_i J + K_c B}{K_m} \right] s + \frac{K_m^2 + K_i B}{K_m} \right]} \quad (19)$$

In hydraulic systems, normally  $K_m \ll K_c$ , therefore,

Put  $K_c = 0$  in above equation.

$$\frac{\theta(s)}{X(s)} = \frac{K_p}{\left[ \frac{K_i J}{K_m} s + \frac{K_m^2 + K_i B}{K_m} \right]} = \frac{K}{\tau s + 1} \quad (20)$$

Where

$$K = \frac{K_p}{\frac{K_m^2 + K_i B}{K_m}} \text{ and } \tau = \frac{K_i J}{K_m^2 + K_i B}$$

Where

$$K_p = 1$$

$$K_m = 4$$

$$K_i = -3$$

$$B = 4$$

$$J = 16.67$$

The value of K and  $\tau$  is

$$K = 1 \text{ and } \tau = 1.50$$

The transfer function of the hydraulic actuator is

$$\frac{\theta(s)}{X(s)} = \frac{1}{\frac{1}{50} s + 1}$$

### III. ROAD PROFILE

#### A. Bump Road Disturbance

The bumpy road disturbance is a primary input to investigate the suspension system. It simulated a totally extreme force for a completely brief time, which include using a car thru a pace bump. This avenue disturbance has a most peak of 5 cm as

shown in Figure 3.

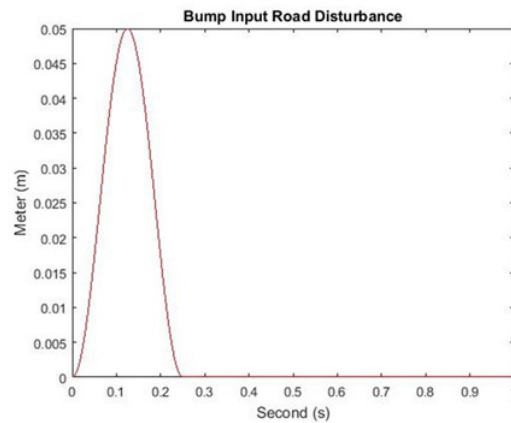

Figure 3: Bump road disturbance

#### B. Random Road Disturbance

Numerous investigations show that it is vital to check a car with a random disturbance of the road to affirm that the spring and suspension absorber reply speedy and efficiently. The random disturbance of the street has a maximum peak of 15 cm and a minimal peak of -15 cm as shown in Figure 4.

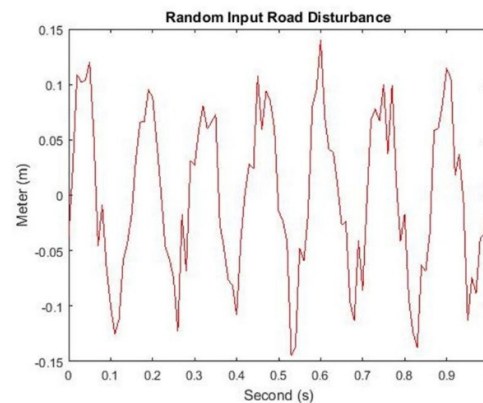

Figure 4: Random road disturbance

#### C. Sine Pavement Road Disturbance

The sine wave input signal can be used to simulate periodic pavement fluctuations. You can check the resilience of the vehicle's suspension system even as the auto experiences periodic wave pavement. The sinusoidal entry pavement check is accomplished through all automotive industries before a new car drives on the street. The alteration of the sinusoidal pavement road has a peak of -10



cm to ten cm, as shown in Figure 5.

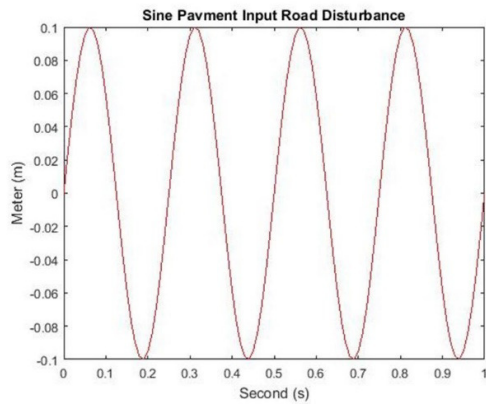

Figure 5: Sine pavement road disturbance

**D. Harmonic Road Disturbance**

Numerous investigations display that when the vehicle speed is steady, the harmonic profile of the road can normally be used within the simulation to verify the steadiness and capability of the designed manage device, further to the device's response repute. The harmonic street disturbance version is shown in Figure 6 with a maximum height of 5 cm and a minimal height of -5 cm.

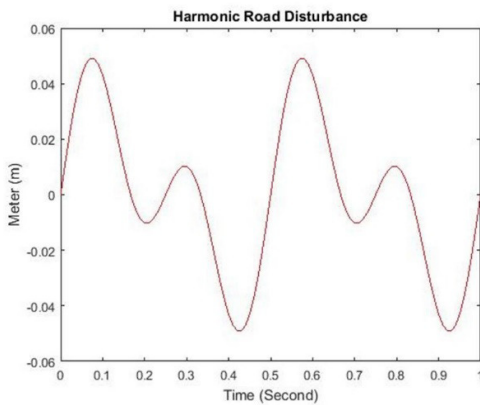

Figure 6: Harmonic road disturbance

**IV. WEIGHTING FUNCTION**

In the H infinity framework, weighting functions are required to reconcile special overall performance goals. The overall performance objective of a remarks system can commonly be decided in terms of necessities on sensitivity functions and / or complementary sensitivity

features or in phrases of some different closed loop functions. The possibilities of occupying a weighted performance within the design of multivariable structures are, first, that part of a vector signal is typically extra essential than others, secondly, measuring every sign will no longer be inside the equal unit. For example, a few a part of the output error signal can be measured in terms of duration, and others may be measured in terms of voltage. Therefore, weighting capabilities play a critical rule for writing those similar parts. The weighting functions are mentioned under.

The weighting function  $W_{act}$  is used to limit the magnitude and frequency content of the active control force signal. Choosing

$$W_{act} = \frac{80}{11} \frac{s + 60}{s + 600}$$

$W_{x1}$  and  $W_{x1-x3}$  are used to keep the car deflection and the suspension deflection small over the desired range. The car body deflection  $W_{x1}$  is given as

$$W_{x1} = \frac{508.1}{s + 56.55}$$

The suspension deflection is used via weighting function  $W_{x1-x3}$ . The weighting function is given as

$$W_{x1-x3} = \frac{15}{0.2s + 1}$$

**V. THE PROPOSED CONTROLLER DESIGN**

The layout of the active suspension system to offer consolation to passengers and riding on the road is advanced the usage of the layout of  $H_{\infty}$  and  $\mu$ -synthesis controllers. In the active suspension system, the proposed design of the controllers covered the dynamics of the hydraulic actuator. To consider the difference between the actuator model and the actual actuator dynamics, a first-order model of the actuator dynamics has been used, as well as an uncertainty model. The fundamental goal of the controller design is to limit suspension deflection, body acceleration and body travel. The synthesis technique is used to design the proposed controllers attaining the overall performance goal by way of minimizing the norm of the weighted

transfer feature. Figure 7 indicates the active suspension system with  $H_\infty$  and  $\mu$ -synthesis controllers interconnections block diagram including a hydraulic actuator.

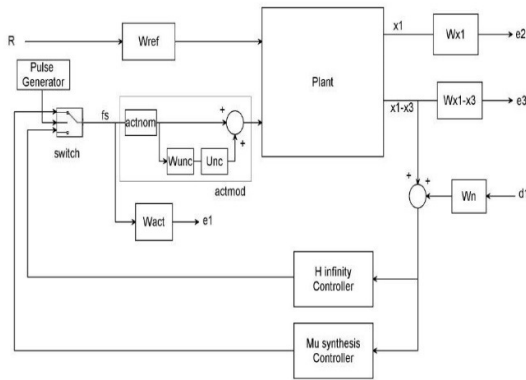

Figure 7: Active suspension system with  $H_\infty$  and  $\mu$ -synthesis controllers system interconnections block diagram

In Figure 7, the plant represents the suspension model of a vehicle room, the  $H_\infty$  controller  $H$  is designed by the  $H_\infty$  technique.  $e_1$ ,  $e_2$  and  $e_3$  are the primary, 2nd and third outputs after influencing the weighting features. A  $\mu$  synthesis controller is synthesized the usage of D-K iteration. The D-K iteration method is an approach to synthesis that attempts to synthesize the controller. There are manipulate inputs: the street disturbance sign and the energetic manipulate pressure. There are 3 measurement output indicators, suspension deflection, body acceleration and body travel. The pulse generator switches among the two systems in  $\mu$  seconds. In practice, suspension deflection may be measured with an acoustic or radar transmitter / receiver, even as speed is commonly acquired through integrating the acceleration measured the use of the accelerometer.

There are two functions for the weighted feature popular: for a given trendy, there will be an immediate evaluation for specific performance objectives and they may be used to recognize the frequency facts incorporated within the evaluation. The output or feedback signal  $y$  is

$$y = ((x_1 - x_3) + d_1 \times W_n)$$

The controller acts at the  $y$  signal and to provide the active control force signal. The  $W_n$  block modeled

the sensor noise inside the channel.  $W_n$  gets a sensor noise of 0.05 m.

$$W_n = 0.05$$

$W_n$  is used to model the noise of the displacement sensor. The value of the street disturbance is scaled the usage of the burden  $W_{ref}$ . suppose the maximum disturbance of the street is 0.1 m, because of this

$$W_{ref} = 0.1$$

## VI. RESULT AND DISCUSSION

To ensure that the design of our controller achieves the preferred objective, the active suspension system is simulated with the following parameter values, as shown in Table I.

Table I: Parameters of quarter vehicle model

Model parameters	symbol	symbol Values
Vehicle body mass	$m_1$	300 Kg
Wheel assembly mass	$m_2$	40 Kg
Suspension stiffness	$k_1$	15,000 N/m
Tire stiffness	$k_2$	150,000 N/m
Suspension damping	$D$	1000 N-s/m

### A. Active Suspension System Control Targets Simulation Output Specifications

Each active suspension system control targets (body travel, body acceleration and suspension deflection) has its own output specifications while the vehicle in motion.

The body travel output should be the minimum vertical amplitude because the passenger must not feel the road disturbance while the vehicle in motion. In an ideal suspension system, the body travel vertical amplitude is zero.

The body acceleration output should be the minimum vertical acceleration because the passenger must not feel the sudden vertical acceleration while the vehicle hits the road disturbance. In an ideal suspension system, the vertical velocity is constant.

The suspension deflection output should be the same as the road disturbance input because if it is above or below the road disturbance input, it will affect the body travel output.

**B. Time Domain Comparison of the Active Suspension System with  $H^\infty$  and  $\mu$  - synthesis Controllers**

In this subsection, we simulate the active suspension system with  $H^\infty$  controller and active suspension system with  $\mu$  - synthesis controller for suspension deflection, body acceleration and body travel using bump, random, sine pavement and harmonic road disturbances.

**C. Simulation of a Bump Road Disturbance**

The simulation for a bump input road disturbance is shown below. In this simulation, we simulate active suspension system with  $H^\infty$  controller and active suspension system with  $\mu$  - synthesis controller for suspension deflection, body acceleration and body travel.

The body travel, body acceleration and suspension deflection simulation output is shown in Figure 8, Figure 9 and Figure 10 respectively for a bump road disturbance.

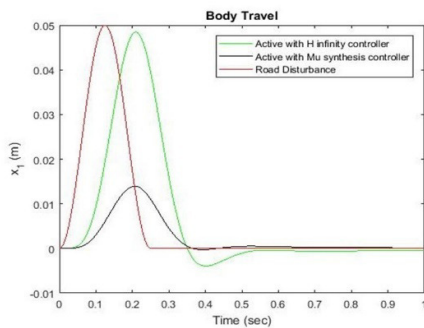

Figure 8: Body travel for bump road disturbance

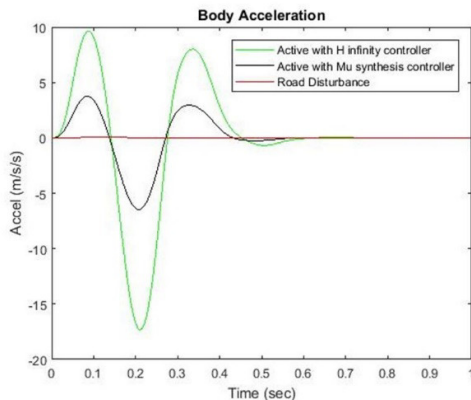

Figure 9: Body acceleration for bump road disturbance

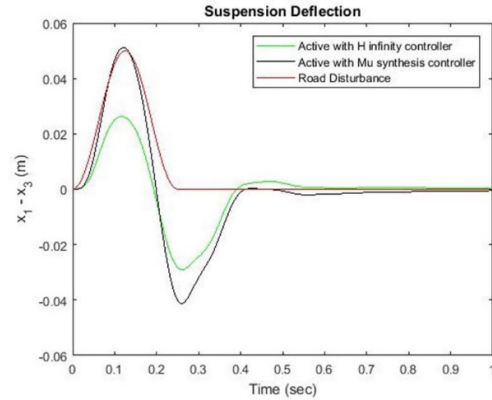

Figure 10: Suspension deflection for bump road disturbance

**D. Simulation of a Random Road Disturbance**

The simulation for a random input road disturbance is shown below. In this simulation, we simulate active suspension system with  $H^\infty$  controller and active suspension system with  $\mu$  - synthesis controller for suspension deflection, body acceleration and body travel.

The body travel, body acceleration and suspension deflection simulation output is shown in Figure 11, Figure 12 and Figure 13 respectively for a random road disturbance.

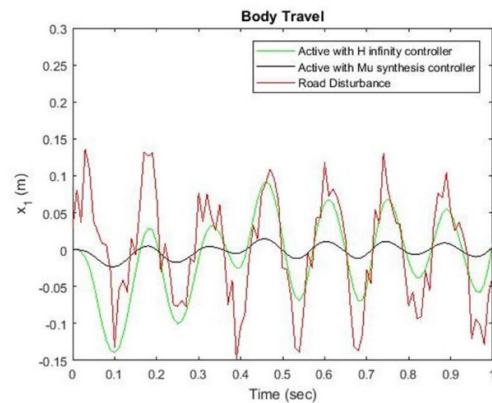

Figure 11: Body travel for random road disturbance



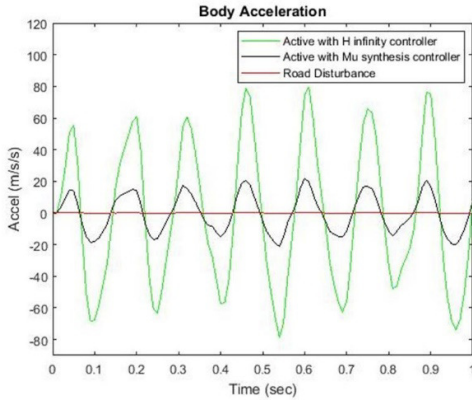

Figure 12: Body acceleration for random road disturbance

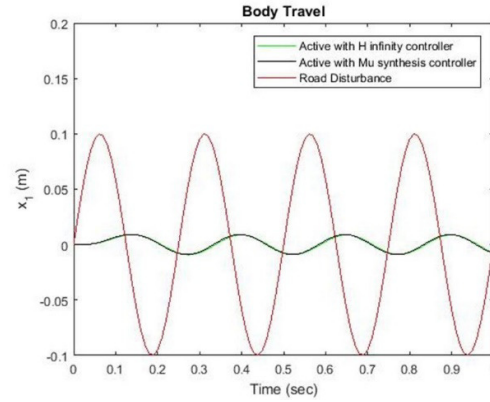

Figure 14: Body travel for sine input pavement road disturbance

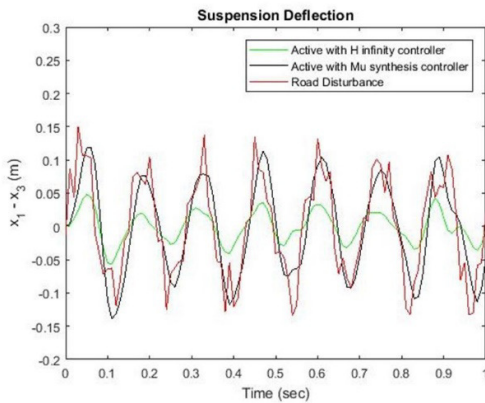

Figure 13: Suspension deflection for random road disturbance

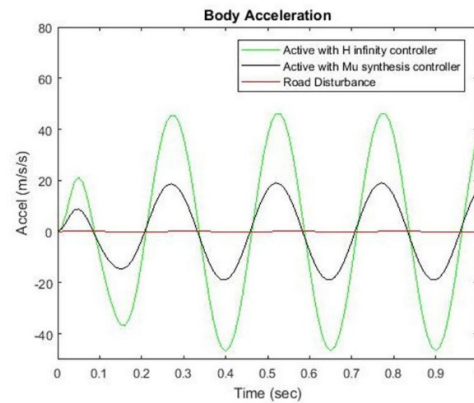

Figure 15: Body acceleration for sine input pavement road disturbance

**E. Simulation of a Sine Pavement Input Road Disturbance**

The simulation for a sine pavement input road disturbance is shown below. In this simulation, we simulate active suspension system with  $H^\infty$  controller and active suspension system with  $\mu$  - synthesis controller for suspension deflection, body acceleration and body travel. The body travel, body acceleration and suspension deflection simulation output is shown in Figure 14, Figure 15 and Figure 16 respectively for a sine pavement road disturbance.

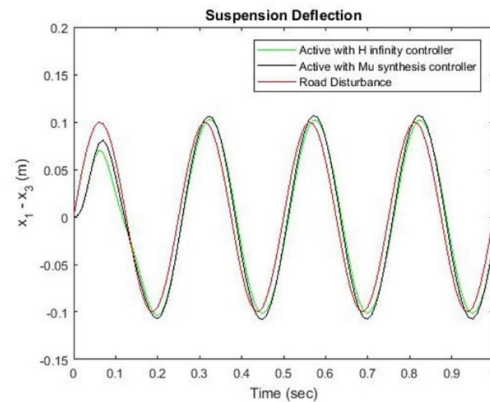

Figure 16: Suspension deflection for sine input pavement road disturbance

**F. Simulation of a Harmonic Road Disturbance**

The simulation for a harmonic input road disturbance is shown below. In this simulation, we simulate active suspension system with  $H^\infty$  controller and active suspension system with  $\mu$  - synthesis controller for suspension deflection, body acceleration and body travel.

The body travel, body acceleration and suspension deflection simulation output is shown in Figure 17, Figure 18 and Figure 19 respectively for a harmonic road disturbance.

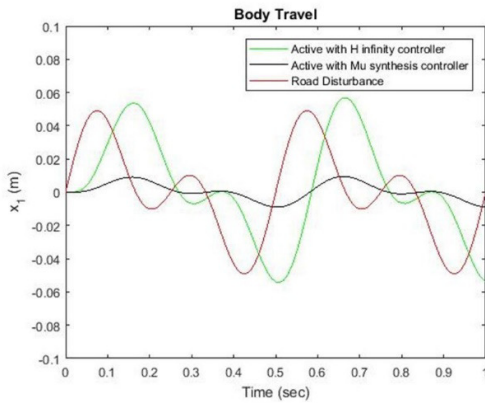

Figure 17: Body travel for harmonic road disturbance

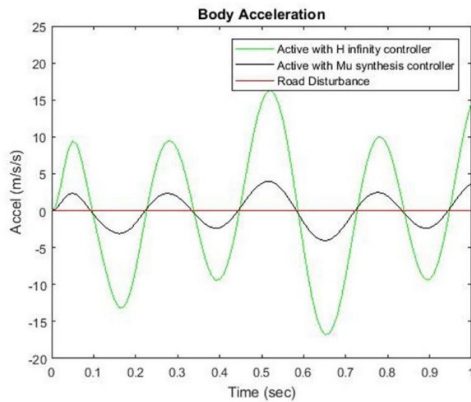

Figure 18: Body acceleration for harmonic road disturbance

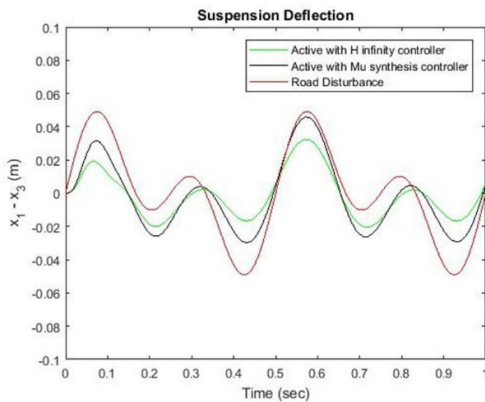

Figure 19: Suspension deflection for harmonic road disturbance

**G. Frequency Domain Comparison of the Active Suspension System with  $H^\infty$  and  $\mu$  - synthesis Controllers**

The frequency domain analysis of the active suspension system with  $H^\infty$  controller and active suspension system with  $\mu$  - synthesis controller to body travel, body acceleration and suspension deflection is presented below.

**H. Body Travel**

The bode plot comparison of the active suspension system with  $H^\infty$  controller and active suspension system with  $\mu$  - synthesis controller for body travel is shown in Figure 20 bellow.

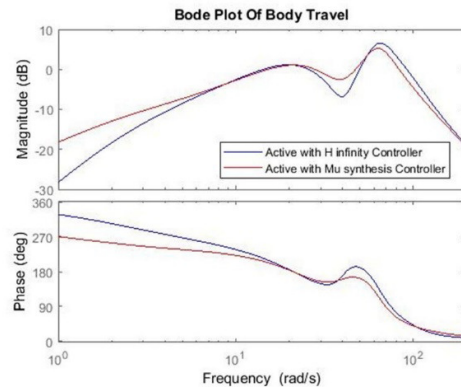

Figure 20: Bode plot of body travel

**I. Body Acceleration**

The bode plot comparison of the active suspension system with  $H^\infty$  controller and active suspension system with  $\mu$  - synthesis controller for body acceleration is shown in Figure 21 bellow.

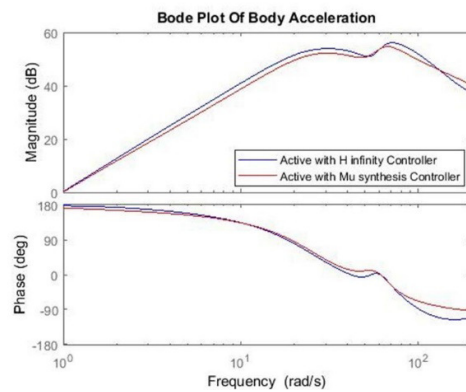

Figure 21: Bode plot of body acceleration

**J. Suspension Deflection**

The bode plot of the active suspension system with  $H_\infty$  controller and active suspension system with  $\mu$  - synthesis controller for suspension deflection is shown in Figure 22 below.

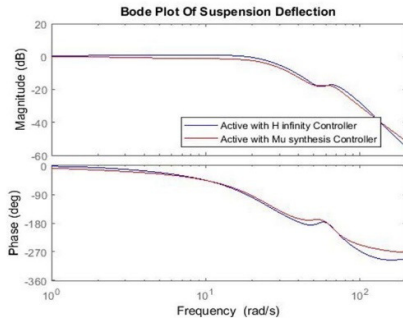

Figure 22: Bode plot of Suspension deflection

**K. Frequency Domain Comparison Result of Active Suspension System with  $H_\infty$  and  $\mu$  - synthesis Controllers**

While in motion, human body is more prone to the possessions of shock in the frequency cord of 10–20 Hz. Figures 23, Figure 24 and Figure 25 shows the frequency feedback plot of suspension deflection, body acceleration and body travel of robust H-infinity and robust Mu-synthesis technique. From the result, it is evident that there exist two natural frequency which can be classified as lower frequency and higher frequency. At higher frequency, the active controller with mu-synthesis controller shows a good response, whereas, at lower frequency, both the active controller with H infinity and mu-synthesis controllers is more effective is suppressing the vibration. Comparing all the results, it is clear that at higher frequency, the active controller with mu-synthesis controller shows a good response and both H infinity and mu-synthesis controller has best performance in controlling the shock at low frequency region.

**L. Numerical Values of the Simulation Outputs**

The numerical values of the simulation output for the control targets body travel, body acceleration and suspension deflection for the four road disturbances is shown in Table 2, Table 3 and Table 4 below.

Table II: Numerical values of the body travel simulation output

No	Systems	Bump	Random	Sine	Harmonic
1	Road Profile	0.05m	0.15m	0.1m	0.05m
2	$H_\infty$	0.049m	0.09m	0.01m	0.055m
3	$\mu$ - synthesis	0.013m	0.01m	0.01m	0.011m

No	Systems	Bump	Random	Sine	Harmonic
1	Road Profile	0.05m	0.15m	0.1m	0.05m
2	$H_\infty$	0.049m	0.09m	0.01m	0.055m
3	$\mu$ - synthesis	0.013m	0.01m	0.01m	0.011m

Table II shows us the active suspension system with  $\mu$  - synthesis controller have the minimum body travel amplitude in the random road disturbance and the active suspension system with  $\mu$  - synthesis controller shows the best performance in the random road profile.

Table III: Numerical values of the body acceleration simulation output

No	Systems	Bump	Random	Sine	Harmonic
1	Road Profile	1 m/ s <sup>2</sup>	5 m/ s <sup>2</sup>	2 m/ s <sup>2</sup>	1 m/ s <sup>2</sup>
2	$H_\infty$	10 m/ s <sup>2</sup>	80 m/ s <sup>2</sup>	45 m/ s <sup>2</sup>	16 m/ s <sup>2</sup>
3	$\mu$ - synthesis	4 m/ s <sup>2</sup>	20 m/ s <sup>2</sup>	18 m/ s <sup>2</sup>	3 m/ s <sup>2</sup>

Table III shows us the active suspension system with  $\mu$  - synthesis controller have the minimum body acceleration amplitude in the harmonic road disturbance and the active suspension system with  $\mu$  - synthesis controller shows the best performance in the harmonic road profile.

Table IV: Numerical values of the suspension deflection simulation output

No	Systems	Bump	Random	Sine	Harmonic
1	Road Profile	0.05m	0.14m	0.1m	0.05m
2	$H_\infty$	0.022m	0.05m	0.1m	0.03m
3	$\mu$ - synthesis	0.05m	0.14m	0.1m	0.05m

Table IV shows us the active suspension system with  $\mu$  - synthesis controller have the suspension deflection amplitude the same as the road disturbance input in all the four road disturbances and the active suspension system with  $\mu$  - synthesis controller shows the best performance in all the four road disturbances.

**VII. CONCLUSION**

In this paper, the  $H_\infty$  controller and the  $\mu$  - synthesis controllers are efficiently designed using MATLAB / Script for the active suspension system of a quarter car. The layout of a MATLAB script that represents the active suspension system with H infinity controller and  $\mu$  -synthesis controller has been finished and tested with bump, pavement of sinusoidal, random and harmonic disturbances of the road for body travel, body acceleration and suspension deflection. The evaluation of the time

and frequency domain of the active suspension system with  $H^\infty$  controller and  $\mu$ -synthesis controller for body travel, body acceleration and suspension deflection has been analysed.

In the analysis of the time domain, we have tested the 2 systems with bump, pavement of sinusoidal, harmonic and random disturbances of the road and the comparative simulation and the reference outcomes prove the effectiveness of the active suspension system with the  $\mu$ -synthesis controller.

In the evaluation of the frequency domain, the effects show that at a higher frequency, the active suspension system with  $\mu$ -synthesis controller suggests a very good response and within the low frequency region, each the active suspension system with  $H^\infty$  controller and the Active suspension system with  $\mu$ -synthesis controller has the great vibration manipulate performance.

Finally, the comparative simulation and reference consequences prove the effectiveness of the active suspension system with the  $\mu$ -synthesis controller and achieves passenger comfort and the road handling control standards which can be had to make the active suspension system the better suspension system.

## ACKNOWLEDGMENT

First and foremost, I would like to express my deepest thanks and gratitude to Dr.Parashante and Mr.Tesfabirhan for their invaluable advices, encouragement, continuous guidance and caring support during my journal preparation.

Last but not least, I am always indebted to my brother, Taha Jibril, my sister, Nejat Jibril and my family members for their endless support and love throughout these years. They gave me additional motivation and determination during my journal preparation.

## REFERENCES

[1] Gang Wang and Zhijin Zhou "Design and Implementation of  $H^\infty$  Miscellaneous Information Feedback Control for Vehicle Suspension System" Shock and Vibration Volume, Article ID 3736402, 15 pages, 2019.

[2] Peter Benner and Tim Mitchell "Faster and More Accurate Computation of the  $H^\infty$  Norm via Optimization" Society for Industrial and Applied Mathematics, Vol. 40, No. 5, pp. A3609-A3635, 2018.

[3] J. Marzbanrad and N. Zahabi "H $^\infty$  Active Control of a Vehicle Suspension System Exited by Harmonic and Random Roads" Journal of Mechanics and Mechanical Engineering, Vol. 21, No. 1, pp 171-180, 2017.

[4] Kruczek Ales and Stribrsky Antonin "Automotive active suspension – case study on H-infinity control "Recent Researches in Automatic Control, ISBN: 978-1-61804-004-6, 2017.

[5] Wang ChunYan and Deng K "Robust Control for Active Suspension System Under Steering Condition" Science China Press and Springer-Verlag Berlin, Heidelberg, 2017.

[6] Katerina Hyniova "One-Quarter-Car Active Suspension Model Verification" ITM Web of Conferences 9, 03003, 2017.

[7] Abdoljalil Addeha and Abolfazl Ebrahimi "Optimal Design of Robust Controller for Active Car Suspension System Using Bee's Algorithm" Journal of Computational Research Progress in Applied Science & Engineering, ©PEARL publication, 2016.

[8] Nouby M Ghazaly and Abdel-Nasser Sharkawy "H $^\infty$  Control of Active Suspension System for a Quarter Car Model" Article in International Journal of Vehicle Structures and Systems, January, 2016.

[9] Ales Kruczek and Antonin Stribrsky "H $^\infty$  Control of Automotive Active Suspension with Linear Motor" MEMT project no. LN00B073 "Josef Bodek's Research Center of Combustion Engines and Automobiles", 2016.

[10] Gaurav Kumar Sinha "Vibration Control of Car Suspension System Using Different Controllers" International Journal of Advance Reseach in Science and Engineering, Vol. No.6, Issue No.4, April, 2016.

[11] Katerina Hyniova "On Testing of Vehicle Active Suspension Robust Control on An One-Quarter-Car Test Stand" International Journal of Mechanical Engineering, Volume 1, 2016.

[12] Narinder Singh and Himanshu Chhabra "Robust Control of Vehicle Active Suspension System" International Journal of Control and Automation Vol. 9, No. 4 (2016), pp. 149-160.

[13] Panshuo Li, James Lam, Kie Chung Cheung "Experimental Investigation of Active Disturbance Rejection Control for Vehicle Suspension Design" International Journal of Theoretical and Applied Mechanics Volume 1, 2016.