

DC MOTOR SPEED CONTROL WITH THE PRESENCE OF INPUT DISTURBANCE USING NEURAL NETWORK BASED MODEL REFERENCE AND PREDICTIVE CONTROLLERS

Mustefa Jibril^{*1}, Messay Tadese^{*2}, Eliyas Alemayehu Tadese^{*3}

^{*1,2}Msc, School of Electrical & Computer Engineering, Dire Dawa Institute of Technology, Dire Dawa, Ethiopia.

^{*3}Msc, School of Electrical & Computer Engineering, Jimma Institute of Technology, Jimma, Ethiopia.

ABSTRACT

In this paper we describe a technical system for DC motor speed control. The speed of DC motor is controlled using Neural Network Based Model Reference and Predictive controllers with the use of Matlab/Simulink. The analysis of the DC motor is done with and without input side Torque disturbance input and the simulation results obtained by comparing the desired and actual speed of the DC motor using random reference and sinusoidal speed inputs for the DC motor with Model Reference and Predictive controllers. The DC motor with Model Reference controller shows almost the actual speed is the same as the desired speed with a good performance than the DC motor with Predictive controller for the system with and without input side disturbance. Finally the comparative simulation result prove the effectiveness of the DC motor with Model Reference controller.

KEYWORDS: DC motor, Neural Network, Model Reference controller, Predictive controller.

I. INTRODUCTION

Short settling time and minimized steady state errors are favored in technical system of speed managed DC motor. DC motors have many applications in lots of fields of industrial, together with robotics, automobiles, servomechanisms etc. The electric motor systems used in lots of industrial applications require higher performance, reliability and variable speed because of their ease of controllability. The speed control of a DC motor is critical in applications where precision and safety are vital. The speed may be managed either by using the control of armature voltage, field voltage or each relying upon the desired overall performance characteristics of the system. The purpose of a motor speed controller is to take a sign representing the desired speed and to drive a motor at that speed.

II. MATHIMATICAL MODEL OF DC MOTOR

The system structure of a DC motor is shown in Figure 1, including the armature resistance R_a and winding leakage inductance L_a .

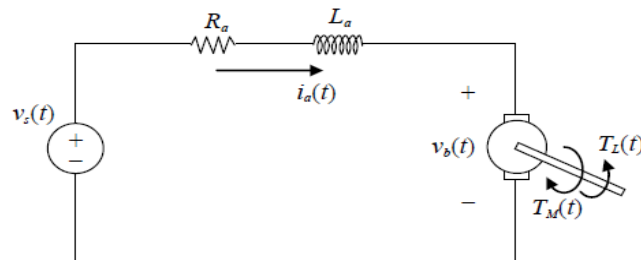

Fig-1: System Structure of a DC Motor

According to the Kirchhoff's voltage law, the electrical equation of the DC motor is described as

$$R_a i_a(t) + L_a \frac{di_a(t)}{dt} + V_b(t) = V_s(t) \text{-----(1)}$$

Where $i_a(t)$ is the armature current, $v_b(t)$ is the back emf voltage and $v_s(t)$ is the voltage source. The back emf voltage $v_b(t)$ is proportional to the angular velocity $\omega(t)$ of the rotor in the motor, expressed as

$$V_b(t) = k_b \omega(t) \text{-----(2)}$$

Where k_b is the back emf constant. In addition, the motor generates a torque T_M proportional to the armature current, given as

$$T_M(t) = k_T i_a(t) \text{-----(3)}$$

Where k_T is the torque constant.

If the input voltage $V_s(t)=V_s$ is a constant, the resulted armature current $i_a(t)=I_a$, angular velocity $\omega(t)=\omega$ and torque $T_M(t)=T$ are also constant in the steady state. From (1) to (3), we have

$$R_a I_a + k_b \Omega = V_s \text{-----(4)}$$

$$T = k_T I_a \text{-----(5)}$$

Under the conservation of power, we know that the input power $I_a V_s$ is equal to the external power $T \Omega$ and the power consumed in the resistance, i.e. $R_a I_a^2$

$$V_s I_a = T \Omega + R_a I_a^2 \text{-----(6)}$$

Substituting V_s in (4) into (6) yields

$$T = k_b I_a \text{-----(7)}$$

From (5) and (7), we know that both k_T and k_b are the same. From (2), we can rewrite (1) and (3) as

$$R_a i_a(t) + L_a \frac{di_a(t)}{dt} + k \omega(t) = V_s(t) \text{-----(8)}$$

$$T_M(t) = k i_a(t) \text{-----(9)}$$

Where $k = k_T = k_b$. Besides, if the DC motor is used to drive an external torque $T_L(t)$ of payload then its mechanical behavior is described as

$$J_M \frac{d\omega(t)}{dt} + B_M \omega(t) = T_M(t) - T_L(t) \text{-----(10)}$$

Where J_M is the rotor moment of inertia and B_M is the frictional coefficient.

Based on (8), (9) and (10), the dynamic equation of the DC motor can be expressed as

$$L_a \frac{di_a(t)}{dt} + R_a i_a(t) + k\omega(t) = V_s(t) \text{-----(11)}$$

$$J_M \frac{d\omega(t)}{dt} + B_M \omega(t) - k i_a(t) = -T_L(t) \text{-----(12)}$$

The state space model representation will have the form

$$\begin{pmatrix} \dot{x}_1 \\ \dot{x}_2 \end{pmatrix} = \begin{pmatrix} -\frac{R_a}{L_a} & -\frac{k}{L_a} \\ \frac{k}{J_M} & -\frac{B_M}{J_M} \end{pmatrix} \begin{pmatrix} x_1 \\ x_2 \end{pmatrix} + \begin{pmatrix} \frac{1}{L_a} & 0 \\ 0 & -\frac{1}{J_M} \end{pmatrix} \begin{pmatrix} V_s \\ T_L \end{pmatrix}$$

$$y = (0 \quad 1) \begin{pmatrix} x_1 \\ x_2 \end{pmatrix}$$

III. THE PROPOSED CONTROLLER DESIGN

The design of model reference and predictive controllers are discussed as follow.

a) Model-Reference Controller Design

The designing of neural model reference control uses two neural networks:

1. A Neural network controller and
2. A Neural network controller for the plant model

As shown in Figure-2 bellow.

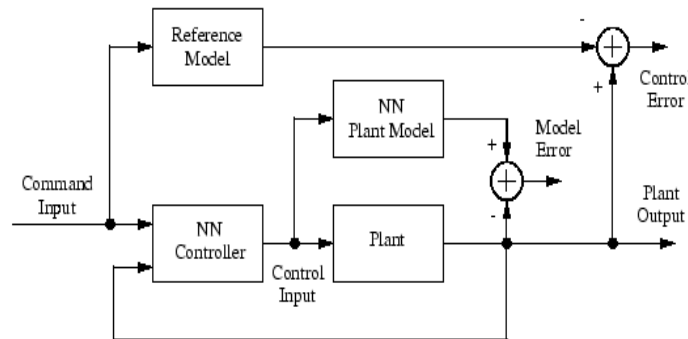

Fig-2: Block Diagram of the Model Reference Controller

There are three sets of controller inputs:

- Delayed reference inputs
- Delayed controller outputs
- Delayed plant outputs

b) Predictive Controller Design

The design of model predictive controller is used to train a neural network to symbolize the forward dynamics of the plant. The prediction error between the plant output and the neural network output is used as the neural network training signal. The system is represented by the Figure 3:

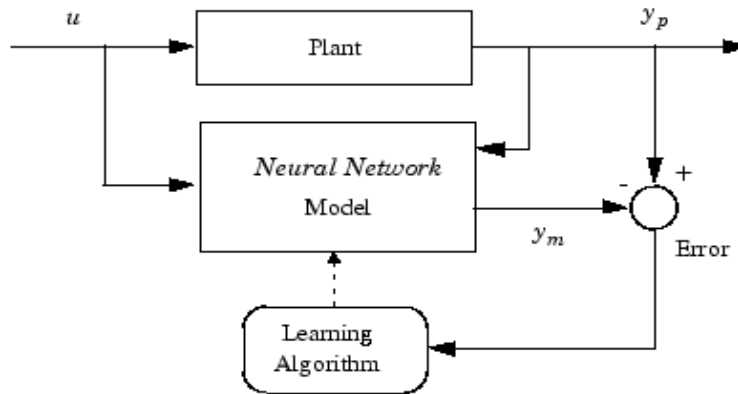

Fig-3: Block Diagram of the Predictive Controller

The neural network architecture, training data and training parameters for model reference and predictive controllers are shown in the Table 1 below

Network Architecture			
Size of hidden layer	6	Delayed plant input	2
Sample interval(sec)	0.1	Delayed plant output	1
Training Data			
Training sample	50	Maximum Plant output	1
Maximum Plant input	4	Minimum Plant output	0
Minimum Plant input	1	Max interval value (sec)	1
Min interval value (sec)			0.5
Training Parameters			
Training Epochs			50

IV. RESULT AND DISCUSSION

Here in this section, the comparisons of the desired and actual speed of the DC motor using random reference and sinusoidal speed inputs for the DC motor with Model Reference and Predictive controllers with and without input side Torque disturbance input. The Simulink model for the DC motor with Model Reference and Predictive controllers using random reference and sinusoidal speed inputs is shown in Figure 4 and Figure 5 respectively.

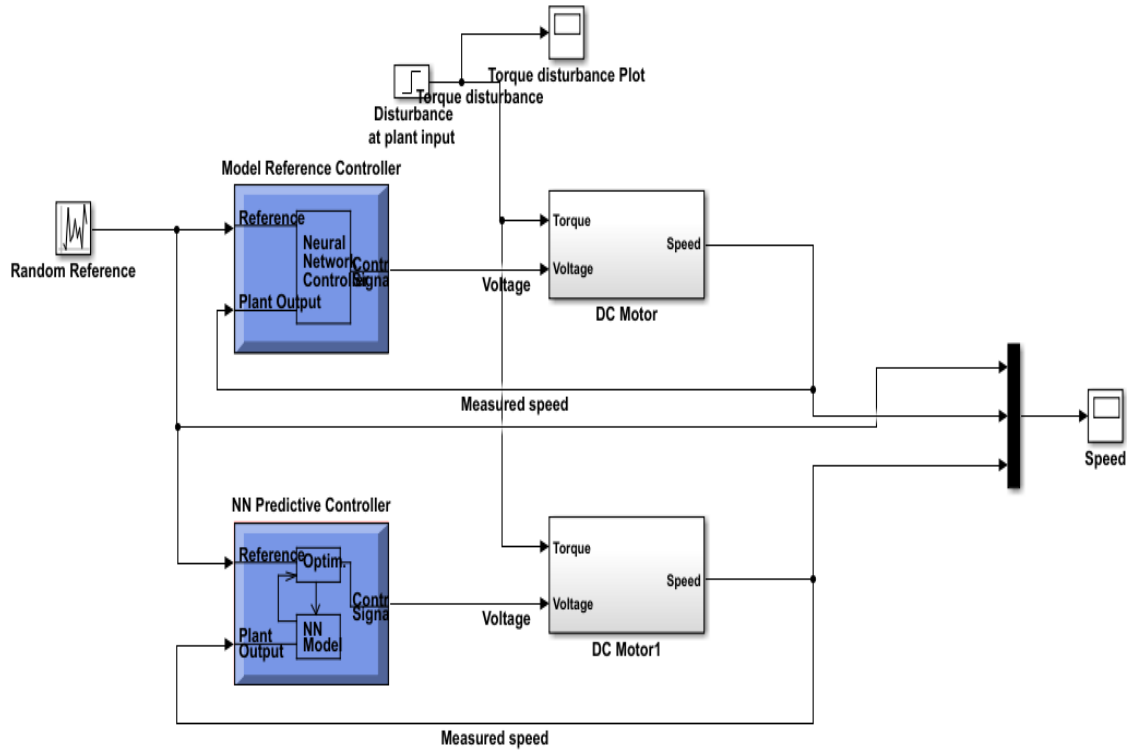

Fig-4: DC Motor with Model Reference and Predictive Controllers Using Random Reference Input.

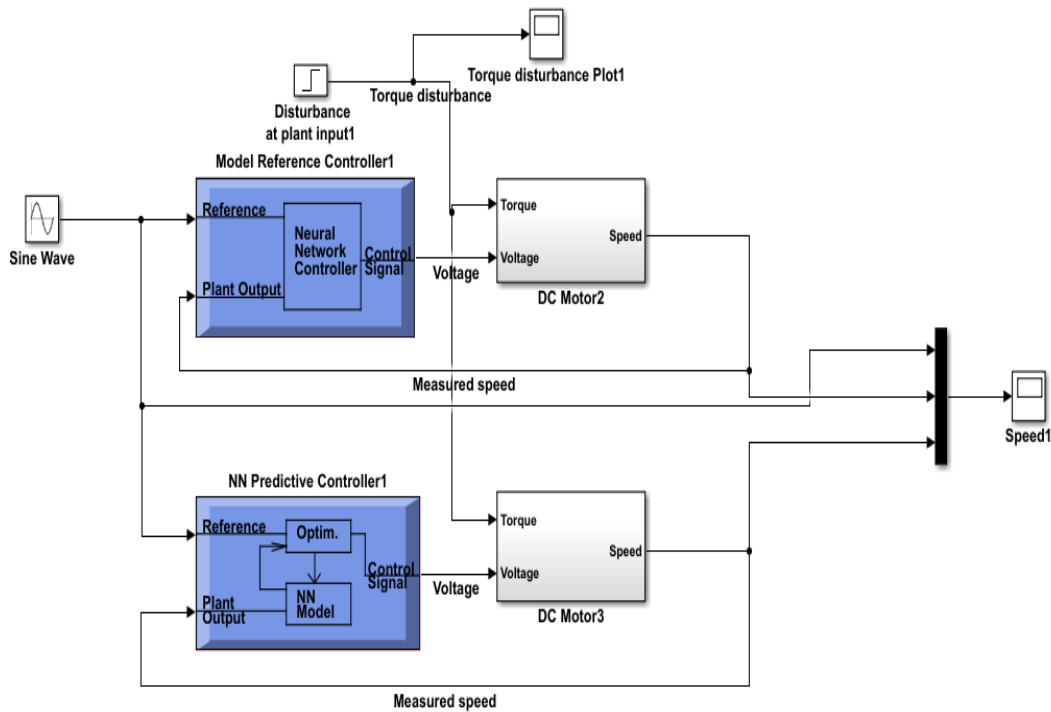

Fig-5: DC Motor with Model Reference and Predictive Controllers Using Sine Wave Input.

a) Comparison of DC motor with Model Reference and Predictive controllers without input disturbance

The simulation result of DC motor with Model Reference and Predictive controllers without input side Torque disturbance for random reference desired speed input is shown in Figure 6 below.

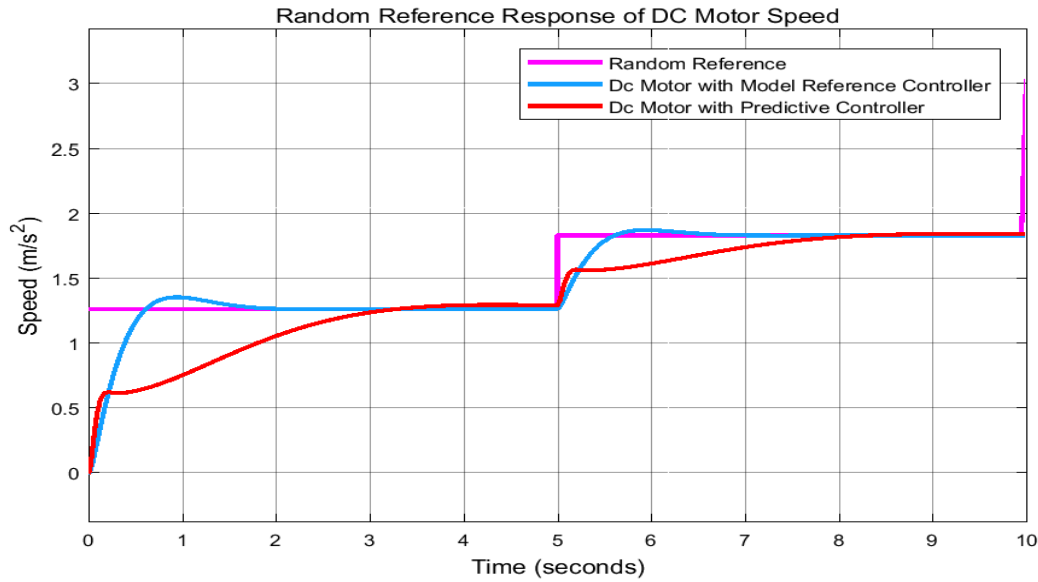

Fig-6: Simulation Result Of DC Motor Without Input Side Torque Disturbance Using Random Reference Input

The simulation result of DC motor with Model Reference and Predictive controllers without input side Torque disturbance for sine wave desired speed input is shown in Figure 7 below.

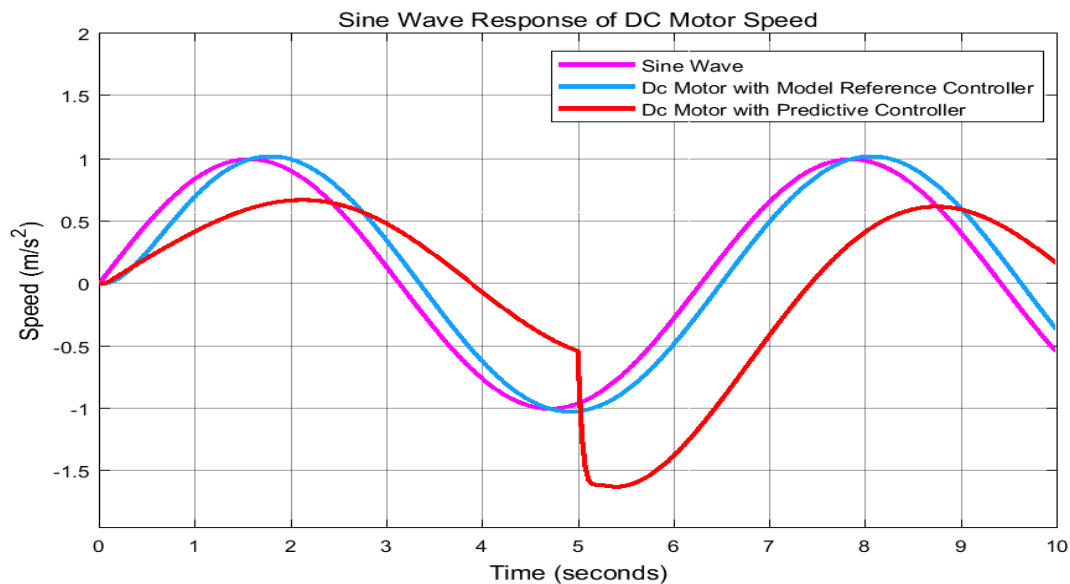

Fig-7: Simulation result of DC motor without input side Torque disturbance using sine wave input

b) Comparison of DC motor with Model Reference and Predictive controllers with input disturbance

The simulation result of DC motor with Model Reference and Predictive controllers with input side Torque disturbance (step with amplitude of 5) for random reference desired speed input is shown in Figure 8 below.

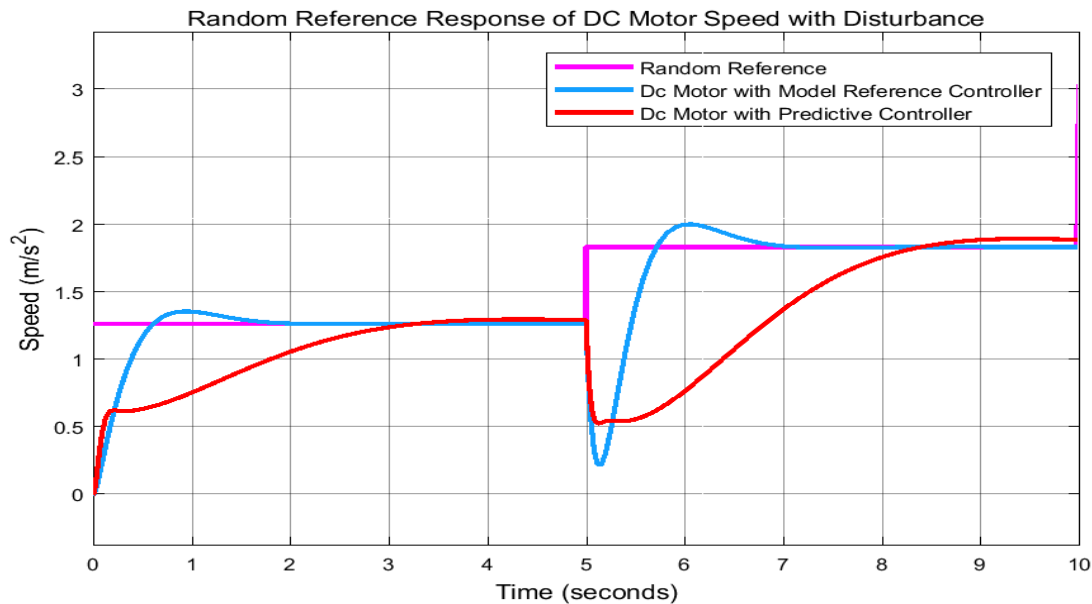

Fig-8: Simulation Result of DC Motor With Input Side Torque Disturbance Using Random Reference Input

The simulation result of DC motor with Model Reference and Predictive controllers with input side Torque disturbance (step with amplitude of 5) for sine wave desired speed input is shown in Figure 9 below.

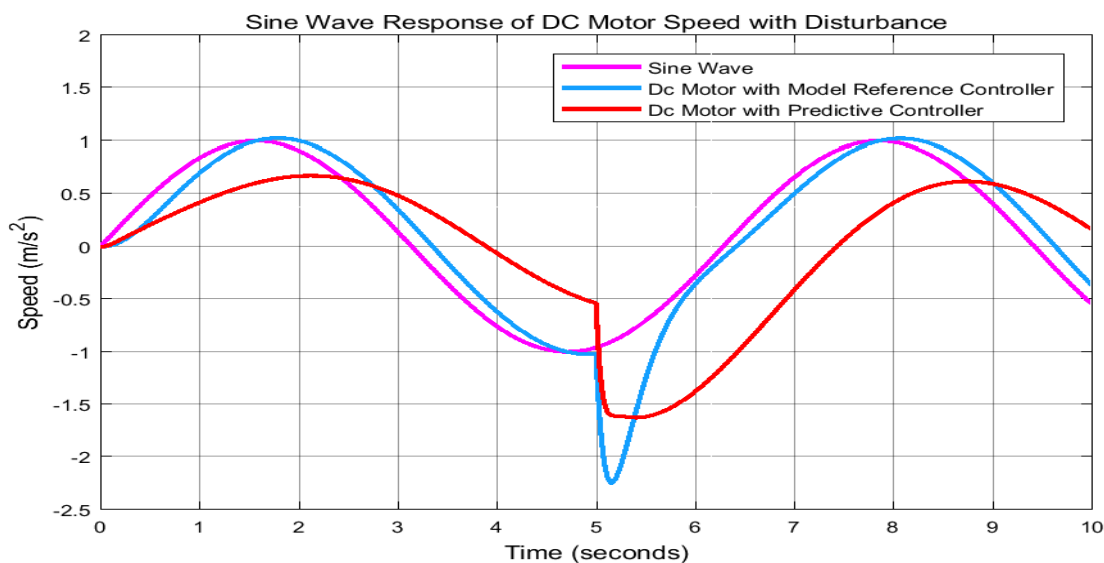

Fig-9: Simulation Result of DC Motor with Input Side Torque Disturbance Using Sine Wave Input

V. CONCLUSION

The mathematical modelling and design of DC motor with the proposed controllers have been done successfully. The performance investigation of the systems including comparisons of the proposed controllers for a speed controlling purpose analysis is done using Matlab/Simulink. The simulation results of DC motor without input side Torque disturbance shows that the DC motor with Model Reference controller almost exactly follow the desired speed efficiently in both the random reference and sine wave inputs. The simulation results of DC motor with input side Torque disturbance shows that the DC motor with Model Reference controller with a small effect of the disturbance at the midpoint of the simulation follow the desired speed in both the random reference and sine wave inputs. Finally the comparative simulation results proved the effectiveness of the DC motor with Model Reference controller.

VI. REFERENCE

- [1] Messay T et al. "Performance Investigation of DC Motor Angular Velocity using Optimal and Robust Control Method" International Journal of Advance Research and Innovative Ideas in Education, Volume-6, Issue-2, 2020.
- [2] N.L Ismail et al. "DC Motor Speed Control using Fuzzy Logic Controller" AIP Conference Proceedings, Vol. 1930, Issue. 1, 2018.
- [3] K. Priyanka et al. "DC Motor Control using PWM" International Journal of Innovative Science and Research Technology, Vol. 3, Issue. 2, 2018.
- [4] Ali A. Hassan et al. "Comparative Study for DC Motor Speed Control using PID Controller" International Journal of Engineering and Technology, Vol. 9, No. 6, pp 4181-4192, 2017.
- [5] Lubica M et al. "Speed Control of DC Motor" American Journal of Mechanical Engineering, Vol. 4, No. 7, pp 380-384, 2016.