

## Review of Waste Heat Utilisation from Data Centres

SETHURAMALINGAM, Ramamoorthy, ASTHANA, Abhishek and WESTON, Peter

Available from Sheffield Hallam University Research Archive (SHURA) at:

<http://shura.shu.ac.uk/26175/>

---

This document is the author deposited version. You are advised to consult the publisher's version if you wish to cite from it.

### Published version

SETHURAMALINGAM, Ramamoorthy, ASTHANA, Abhishek and WESTON, Peter (2019). Review of Waste Heat Utilisation from Data Centres. In: AL-HABAIBEH, Amin, ASTHANA, Abhishek and VUKOVIC, Vladimir, (eds.) The International Conference on Energy and Sustainable Futures (ICESF). Nottingham Trent University.

---

### Copyright and re-use policy

See <http://shura.shu.ac.uk/information.html>



## Review of Waste Heat Utilisation from Data Centres

Ramamoorthy Sethuramalingam, Abhishek Asthana, Peter Weston

*Hallam Energy, Sheffield Hallam University, Department of Engineering and Mathematics,  
United Kingdom*

[r.sethuramalingam@shu.ac.uk](mailto:r.sethuramalingam@shu.ac.uk)

### Abstract

Rapidly increasing global internet traffic, mobile internet users and the number of Internet of Things (IoT) connections are driving exponential growth in demand for data centre and network services, which in turn is driving their electricity demand. Data centres now account for 3% of global electricity consumption and contribute to 4% of the global greenhouse gas emissions. This study discusses the potential of reusing the waste heat from data centres. An overview of imbedding heat recovery systems into data centres is presented. The implications of economic cost and energy efficient heat recovery systems in data centre buildings are also discussed. The main problems with implementing heat recovery systems in existing data centre designs are (i) high capital costs of investment and (ii) low temperatures of the waste heat. This study suggests alternatives that could allow data centre operators to utilise waste heat with more efficiencies. It also discusses how liquid-cooled data centres can be more efficient in utilising their waste heat than the air-cooled ones. One possible solution suggested here is that data centre operators can decrease their environmental impact by exporting waste heat to the external heat networks. The barriers in connecting datacentres to heat networks are discussed and suggestions to overcome those barriers have been provided.

**Keywords:** Data centres, District heating, Waste heat recovery, Liquid cooling, Energy efficiency.

### 1. Introduction

Global internet traffic has tripled since 2015 and is expected to further double by 2022 to 4.2 zettabytes per year (4.2 trillion gigabytes) [1, 2, 3]. The number of mobile internet users is expected to increase from 3.6 billion in 2018 to 5 billion by 2025, while the number of

Internet of Things (IoT) connections is expected to triple from 7.5 billion in 2018 to over 25 billion by 2025 [4].

Most of the world's Internet Protocol (IP) traffic goes through data centres (DCs). Greater connectivity is therefore driving up demand for data centre services and energy use (mostly electricity), with multiplying effects: for every bit of data that travels the network from data centre to end users, another 5 bits of data are transmitted within and among data centres [5]. Global data centre electricity demand in 2018 reached an estimated 198 TWh [6].

Heating and cooling in buildings and industry accounted for 50% of the total energy consumption in the Europe in 2012 [7]. Along with other industries, DCs are producing a reliable and stable waste heat source. As per a study in 2016 by Ascierio et al [8], DCs in Europe generate 56 TWh of waste heat. Thus, there is significant pressure on DC sector to reduce its energy consumption.

DC operators are thus investing heavily in low energy designs such as implementing heat recovery systems [9, 10]. DCs are using various types of cooling solutions such as Computer Room Air Handling (CRAC) and water cooled systems. Another important concern is the cost effectiveness of implementing heat recovery systems into existing DCs. The choice of correct heat recovery system is thus, very important. Using data centre cooling solutions such as air handling unit (CRAC) provide opportunity to recover up to 50% energy from its waste heat [9]. Data centre heat recovery systems have been already used by data centres in Nordic countries. High heat density and efficient heat recovery allowed these countries to remove the waste heat efficiently and utilise it in district heating in Sweden and Finland [11]. Similarly, there is huge demand for data centre heat recovery systems all over Europe. This study analyses the present cooling systems in the data centres and suggests possible approaches to utilise the waste heat in existing DCs.

## **2. Literature Review**

There are many studies have around the energy efficiency of DCs but only a few have discussed the utilisation of waste heat recovery from DCs. Typically, all medium-sized DCs produce low temperature waste heat. The real DCs energy efficiency has evaluated by Lu et al for potential of capturing the waste heat [12]. The study found that, 97 % energy consumption can be recovered as waste heat from the data centre's total energy consumption. It showed that a DC operating at 1 MW waste heat capacity is enough to fulfil the heat demand of 60,000 m<sup>2</sup> space. An article by Ebrahimi et al. [13] analysed the thermodynamics of ultra-low

temperature waste heat recovery systems. The economic analysis of the study indicated a payback period for ultra-low temperature waste heat recovery system of 4 to 8 years. At present, the biggest barrier is high capital cost investment in low grade heat recovery systems. It is also to be noted that, operating temperature of the data centres also plays key role in energy consumption. A study by Carbo et al. noted that there is a 3% increase in the energy consumption when there is increase in the inlet water temperature for cooling [14]. Similarly, the same phenomenon was reported, where a server's energy consumption increased by around 11 % when using an advanced microchip device. This indicates that there should always be a balance between server operating temperature and energy consumption. The possibility of using the DCs waste heat in London city District Heating (DH) has been discussed by Davies et al. [15]. The study predicted a profit of £875,000/year for 3.5 MW waste heat from a DC. Many studies forecast enormous saving in energy spend along with low payback periods, even though it is difficult to utilise the low-grade waste heat in the commercial market. However, these studies rarely discuss the actual possibilities and practicalities of utilising the data centre waste heat. Implementing the waste heat recovery system in the DCs can be quite complicated due to various logistical and economic factors. This study will discuss a systematic approach to analysis the waste heat recovery from a real DC.

### 3. Methodology

The potential for waste heat utilisation is evaluated by conducting a literature review on:

- Measuring energy efficiency
- Cooling technologies available for DCs
- Utilisation of waste heat
- Barriers in utilising the waste heat

The potential for waste heat utilization from DCs was analysed by conducting a literature review on cooling technologies and solutions for waste heat utilisation. The methodology behind analysing energy efficiency metrics, the economic and emission analysis, and systematic change process for adapting to waste heat utilisation are presented below. Parssinen (2016) analysed 20 metrics includes six different energy-efficiency domains with consumption, seven technology domains and overlay metrics.

Waste heat utilisation economics in DH are based on the assumption that waste heat will replace both solid fuel CHP and heat-only boiler (HOB) production in the DH network. Variable costs of heat production are determined the increased costs of electricity

consumption due to Heat Pumps (HP), reduction in fuel utilisation for CHP and HOB and the capital investment for HPs. Income loss from export of electricity from CHP was also considered.

### 3.1 Measuring energy efficiency

The ideal objective for a DC is to become a net-zero energy building (NZEB). In NZEB, servers are included in the overall energy plan of the building. DC energy contributes to the energy demand in advanced energy efficient buildings. DC operators should establish project targets for energy reuse effectiveness (ERE). Better ERE reduces the renewable energy requirements of the building [16].

ERE and power usage effectiveness (PUE) by themselves are not sufficient for engineering analysis purposes [17]. Additional metrics required include return temperature index (RTI), power density efficiency (PDE), performance per watt (PPW), workload power efficiency (WPE), network power usage effectiveness (NPUE), data center workload power efficiency (DWPE), fixed to-variable energy ratio (FVER), supply heat index (SHI), return heat index (RHI), system power usage effectiveness (sPUE), and data center energy productivity (DCeP). These metrics provide a more complete view of DCs energy usage and is used for energy efficiency optimisation and equipment selection.

PUE and ERE are most common ways to evaluate the energy usage effectiveness and energy reuse in the DCs. PUE is defined as the total annual energy divided by the total annual energy used in the IT [16]. PUE-based metrics are not useful for DC energy analysis. The PUE variables are difficult to measure and calculate when facilities or primary equipment are shared. With energy reuse, the PUE value could go below 1.0, but this is not allowed, which is contrary to PUE definition [18]. PUE ignores IT load changes, and it does not address the DC utilization level [19].

$$\text{PUE} = \frac{\text{Total Energy}}{\text{IT Energy}} \quad (1)$$

$$= \frac{\text{Cooling} + \text{PowerDistribution} + \text{Misc} + \text{IT}}{\text{IT}} ; 1.0 \leq \text{PUE} \leq \infty \quad (2)$$

ERE includes the reuse of energy from a DC to PUE which must be reused outside the DC. Energy Reuse Factor (ERF) can be used to calculate ERE from the site PUE [28]. The ERE and ERF equations are;

$$\text{ERE} = \frac{\text{Total Energy} - \text{Reuse Energy}}{\text{IT Energy}}; 0 \leq \text{ERE} \leq \infty \quad (3)$$

### 3.2 Cooling Technologies in Data centres

DC cooling is an essential part of DC efficiency. For safe functioning of servers, the air temperature in the servers should be maintained at 18 to 27 °C [20]. Traditionally, DC operators have tried to maintain them as cool as possible. However, with the rising costs of cooling, the system needs to be optimised for each DC individually.

Servers in DCs are packed in racks that are cooled by cold air entering from the front and hot air leaving from the back. Racks are usually arranged back-to-back to create cold and hot channels to avoid the mixing of hot and cold airs and thus maximising the cooling efficiency. Fig. 1 shows a schematic of waste heat recovery system for a remote air-cooled DC, where waste heat is utilised in a DH network. The chilled water is pumped to the computer room air conditioner (CRAC). CRACs supply chilled air that is injected into the cold aisle via a perforated and raised floor. Waste heat is recovered from the hot aisles through ventilation or redirected to the CRAC. The collected waste heat can go through different stages, e.g., an evaporator and condenser and subsequently a HP to be able to be used in the reuse application (e.g., the DH network) [21].

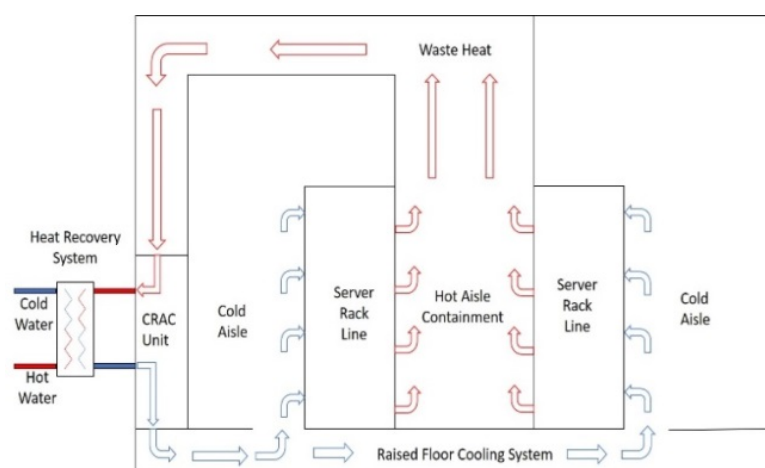

Figure 1: Typical hot aisle air containment system in data centre with heat recovery system.

### 3.3 Utilisation of waste heat:

Modern cooling technologies such as liquid cooling increase the efficiency of heat recovery although it could equally be utilised from air-cooled DCs. DCs are beginning to capitalise on waste heat, but the scale of utilisation is still rather small considering its economic potential. This section discusses how and where waste heat could be utilised.

The main considerations in waste heat utilisation are the proximity of heat demand and profitability. The amount and quality of waste heat, and the profitability, depend a lot on the choice of cooling technologies.

The best points for heat recovery are summarised in [10] and [15]. The best points in air-cooled servers are at the return of air flow to the CRAC where heat can be captured between 25 and 35°C, whereas liquid cooling can capturing it at 50–60°C due to capturing it closer to the central processing units (CPUs) and other components, which are hotter (up to 85 °C). The higher specific heat capacities of liquids allow circulating water temperature to be set close to 60°C without compromising CPU performance. This eliminates the need for chillers and CRACs [9] and can increase processor performance by 33% compared to air-cooled systems [22, 23]. Waste heat could also be captured in the chilled supply water as cold as 10–20°C [15].

HPs could be used in DCs to upgrade the waste heat temperatures up to 95°C which would make it useful for many other processes (e.g DH networks). HPs in DCs have typical COP values of 2 to 7, depending on the number of cycles and the temperature [15]. Increased electricity consumption in HPs decreases the PUE value of the system but by utilising the waste heat, it decreases the ERE value and improves the energy efficiency of the DC.

Various uses for waste heat exist, e.g. small-scale and location-specific solutions (e.g., heating swimming pools) do not require heavy investments as compared to large-scale installations e.g. connection to a DH network. Different applications for waste heat have been studied comprehensively, for example, in [9] for internal and external uses.

Some DC projects with waste heat utilisation in Nordic countries are summarised in Table 1

*Table 1: DC Projects with Waste Heat Utilisation in Nordic Countries [21]*

Data center projects considering waste heat utilization in the Nordic countries.

Data center operator	Location	IT load capacity	Cooling technology	Waste heat reuse	Estimated amount of recovered waste heat
Apple	Viborg, Denmark	Unknown, (floor area 166,000 m <sup>2</sup> )	Free cooling	District heating	Unknown
Bahnhof (3 operational + 1 under construction)	Stockholm, Sweden	~3 MW (21 MW under construction)	Heat pumps	District heating	600 kW (Pionen) + 500 kW (St Erik) + 1500 kW (Thule)
CSC	Kajaani, Finland	2.4 MW	Free cooling	Other processes	Unknown
TeliaCompany	Helsinki, Finland	24 MW	Unknown	District heating	200 GWh/a
TelecityGroup (5 locations)	Helsinki, Finland	7 MW (2 MW reusing waste heat)	District cooling (+ free cooling)	District heating	4500 block apartments + 500 detached houses
Tieto	Espoo, Finland	2 MW, (floor area 1000 m <sup>2</sup> )	Heat pumps	District heating	~30 GWh/a (~1500 detached houses)
Yandex	Mäntsälä, Finland	10 MW	Free cooling	District heating	~20 GWh/a (~1000 detached houses)

### 3.4 Barriers for waste heat utilisation:

The main barriers limiting the utilisation of waste heat are studied in [10] and [24] and can be categorised as follows:

- Low-quality heat and lack of heat demand
- Seasonal variations in demand
- Need for ancillary heat production
- High investment costs and inconvenient infrastructure
- Differing financial outcome expectations of DC and DH operators
- Information security and reliability
- Business models and mutual contracts
- Thermodynamic limitations

## 5. Conclusions

There is enormous potential for waste heat utilisation from DCs. The barriers for waste heat utilisation are not technical but rather a lack of solutions for DC operators on profitability due to seasonal demand variations and capital costs due to an absence of established and transparent business models of selling waste heat to DH companies. Awareness of energy-related costs must reach decision-makers in the ICT field. A standard way of measuring energy efficiency and waste heat potential needs to be established. In addition, there needs to be sufficient activities from government regulation and legislative enforcement to further enable transformation towards energy efficiency and waste heat utilisation. ERE and PUE values are symptoms of actions. In order to understand the causes and actions required, more detailed energy efficiency metrics, such as those suggested in this article, are required.

## Acknowledgments

This work is sponsored by Innovate UK under KTP Programme No KTP011150 and Impetus Enclosure Systems (Orion).

## References

1. Cisco (2015) "The History and Future of Internet Traffic", , <https://blogs.cisco.com/sp/the-history-and-future-of-internet-traffic>.
2. Cisco (2018) Cisco Global Cloud Index: Forecast and Methodology, 2016–2021., , <https://www.cisco.com/c/en/us/solutions/collateral/service-provider/global-cloud-index-gci/white-paper-c11-738085.pdf>.
3. Cisco (2019) Cisco Visual Networking Index : Global Mobile Data Traffic Forecast Update , 2017 – 2022., , <https://www.cisco.com/c/en/us/solutions/collateral/service-provider/visual-networking-index-vni/white-paper-c11-738429.pdf>.
4. GSM Association (2019) The Mobile Economy, <https://www.gsmaintelligence.com/research/?file=b9a6e6202ee1d5f787cfebb95d3639c5&download>.
5. Cisco (2016) "Cisco Global Cloud Index 2015-2020 - Cisco Knowledge Network Session".
6. Masanet, E. R. et al. (2018), Global Data Center Energy Use: Distribution, Composition, and Near-Term Outlook, Evanston, IL.



7. Eurostat Statistics (Accessed August 2019) Online available in <http://ec.europa.eu/eurostat/statistics-explained/index.php/Energy>.
8. Ascierto R, Donoghue A, Lawrence A, Bizo D (2016) Trends in data centre technology. *Research* 451.
9. Ebrahimi K, Jones G, Fleisher A (2014) A review of data centre cooling technology, operating conditions and corresponding low-grade waste heat recovery opportunities. *Renewable and Sustainable Energy Reviews* 31: 622 - 638
10. Ebrahimi K, Jones G, Fleisher A (2015) Thermo-economic analysis of steady state waste heat recovery in data centres using absorption refrigerant. *Applied Energy* 139:384-397
11. Mikko W, Matti P, Jukka M, Sanna S (2017) Utilizing data centre waste heat in district heating- impacts on energy efficiency and prospects for low-temperature district heating networks. *Energy* 140:1228-1238.
12. Li T, Lu X, Remes M, Viljanen M (2011) Investigation of air management and energy performance in a data centre in Finland: case study. *Energy Build* 43: 3360-72
13. Ebrahimi K, Jones G, Fleischer A (2017) The viability of ultra-low temperature waste heat recovery using organic Rankine cycle in dual loop data centre applications. *Applied Thermal Engineering* 126: 393-406.
14. Carbó A, Oró E, Salom J, Canuto M, Macías M, & Guitart J (2016) Experimental and numerical analysis for potential heat reuse in liquid cooled data centres. *Energy Conversion and Management* 112: 135-145.
15. Davies G, Maidment G, Tozer R (2016) Using data centres for combined heating and cooling: an investigation for London. *Applied Thermal Engineering* 94:296–304.
16. Patterson M, Tschudi W, VanGeet O, Azevedo D (2011) Towards the net-zero data centre: development and application of an energy reuse metric. *ASHRAE* 117:10–7.
17. Pärssinen M (2016) Analysis and forming of energy efficiency and green it metrics framework for sonera helsinki data centre hdc master's thesis espoo, Aalto University.
18. Uddin M, Alsaqour R, Shah A, Saba T (2014) Power usage effectiveness metrics to measure efficiency and performance of data centers. *Applied Mathematics and Information Science* 8 :2207–16. <http://dx.doi.org/10.12785/amis/080514>
19. Fiandrino C, Kliazovich D, Bouvry P, Zomaya A (2015) Performance and energy efficiency metrics for communication systems of cloud computing data centers. *IEEE Transactions on Cloud Computing* Volume 5: 738.
20. ASHRAE (2011) *Thermal Guidelines for Data Processing Environments – Expanded Data Centre Classes and Usage Guidance*. [accessed 30 August 2019].
21. Mikko Wahlroos, Matti Pärssine, Samuli Rinne, Sanna Syri, Jukka Manner (2018) Future views on waste heat utilization - Case of data centres in Northern Europe. *Renewable and Sustainable Energy Reviews* 82:1749 -1764.
22. Finnish Energy Industries (2006) *Kaukolämmön käsikirja* .In Finnish, District Heating Handbook, Helsinki.
23. Ellsworth M, Iyengar M (2009) Energy efficiency analyses and comparison of air and water cooled high performance servers. *Proceeding of ASME Inter Conference San Francisco, USA*. 19-23.
24. Linna O (2016) *Kansainvälinen katsaus datakeskusten hukkalämmön hyödyntämiseen*, In Finnish, Global overview on data center waste heat utilization. Bachelor's thesis Espoo, Finland, Aalto University.