

Demonstration of the Effect of Centre of Mass Height on Postural Sway Using Accelerometry for Balance Analysis

OJIE, Oseikhuemen Osemekhian Davis, SAATCHI, Reza
<<http://orcid.org/0000-0002-2266-0187>> and SAATCHI, Mahdieh

Available from Sheffield Hallam University Research Archive (SHURA) at:

<http://shura.shu.ac.uk/26164/>

This document is the author deposited version. You are advised to consult the publisher's version if you wish to cite from it.

Published version

OJIE, Oseikhuemen Osemekhian Davis, SAATCHI, Reza and SAATCHI, Mahdieh (2020). Demonstration of the Effect of Centre of Mass Height on Postural Sway Using Accelerometry for Balance Analysis. *Technologies*, 8 (2), e20.

Copyright and re-use policy

See <http://shura.shu.ac.uk/information.html>

Article

Demonstration of the Effect of Centre of Mass Height on Postural Sway Using Accelerometry for Balance Analysis

Oseikhuemen Osemekhian Davis Ojie ¹, Reza Saatchi ^{2,*} and Mahdieh Saatchi ³

¹ Cultural Communication and Computing Research Institute, City Campus, Sheffield Hallam University, Sheffield S11WB, UK; ojieose@gmail.com

² Materials and Engineering Research Institute, Sheffield Hallam University, City Campus, Sheffield S11WB, UK

³ Shahid Sadoughi University of Medical Sciences and Health Services, Yazd 89151-73160, Iran; mahdieh.saatchi@gmail.com

* Correspondence: r.saatchi@shu.ac.uk

Received: 26 February 2020; Accepted: 21 April 2020; Published: 22 April 2020

Abstract: The effect of center of mass (COM) height on stand-still postural sway analysis was studied. For this purpose, a measurement apparatus was set up that included an accelerometry unit attached to a rod: three plumb lines, positioned at 50 cm, 75 cm, and 100 cm to the end of the rod, each supported a plumb bob. Using a vice mechanism, the rod was inclined from vertical (0 degree inclination) in steps of 5 degrees to 90 degrees. For each inclination, the corresponding inclination angle was manually measured by a protractor, and the positions of the three plumb bobs on the ground surface were also manually measured using a tape measure. Algebraic operations were used to calculate the inclination angle and the associated displacements of the plumb bobs on the ground surface from the accelerometry data. For each inclination angle, the manual and accelerometry calculated ground displacement produced by each plumb bulb were close. It was demonstrated that the height of COM, where the measurement was taken, affected the projected displacement on the ground surface. A higher height produced a greater displacement. This effect has an implication in postural sway analysis where the accelerometry readings may need comparison amongst subjects with different COM heights. To overcome this, a method that normalized the accelerometry readings by considering the COM height was proposed, and the associated results were presented.

Keywords: center of mass; balance analysis; accelerometry; inverted pendulum measurement

1. Introduction

Postural sway during quiet standing is determined by the movement of the center of pressure (COP) position. The movement of COP under the feet regulates the center of mass (COM) of a person, based on the operation of the inverted pendulum model [1]. The COM position is an imaginary point at which the total mass of the body can be assumed to be concentrated [2]. Postural sway assessment during quiet standing is of importance in the study of kinesiology, neurology, gerontology, motor control research, physical rehabilitation, and other human movement areas [3]. In balance studies, during quiet standing, the COM sway can be used to determine the contribution of each sensory system, i.e., visual, somatosensory, and vestibular, to postural control and to estimate their functionalities [4]. Therefore, the study of COM position in analysis of sensory system dysfunction and fall risk is important in the diagnosis of the underlying dysfunctions in these systems.

Various methods have been proposed for COM estimation. In quiet standing, the kinematic method is used and is based on the definition of COM [1,5–7]. Clinically, postural assessment could be carried out using a force platform. However, these systems are expensive and are only available in specialized centers. Additionally, a growing body of evidence suggests that poor designs of the posturographic hardware may significantly affect the assessment of the COP signal [8,9]. An alternative approach to force platform in postural analysis is accelerometry. Accelerometry is the use of an accelerometer to quantify human movement patterns [10–12]. The benefits of using accelerometry compared to force platforms in gait analysis includes lower cost, portability (i.e., test is not restricted to a laboratory environment), and reduced size (allowing balance measurements to be performed during walking) [10,11]. The use of accelerometry in human activity analysis and postural recognition has been reported in a number of studies [13,14].

A wearable device with a tri-axial accelerometer on the chest region and a suitable algorithm was reported to be able to detect patterns of step and determined walking postures [15]. The proposed system was around 93% accurate, in comparison with that of a physiotherapist.

Postural assessment can be carried out by measuring sway in stand-still position. A commonly used test for this purpose is the modified Clinical Test for Sensory Interaction of Balance (mCTSIB). It consists of four balance assessments based on: (i) eyes open standing on a firm surface, (ii) eyes closed standing on a firm surface, (iii) eyes open standing on a flexible surface (such as a foam), and (iv) eyes closed standing on a flexible surface [16]. In postural control, the goal is to maintain COM within the limits of stability, thus direct measurement of COM may provide an understanding of the mechanisms responsible for balance control [17]. A number of studies reported the use of accelerometers and gyroscopes to quantify sway metrics for fall detection of balance deficit in the elderly at risk of falling and in patients with Parkinson disease, multiple sclerosis, or Alzheimer disease [18–20].

For balance tests, it may be necessary to compare the data from a patient against groups of patients or against the data from healthy control subjects. Diagnostic features can be obtained through averaging over a number of measurements of healthy subjects [21]. The use of accelerometers to measure COM sway has been reported in several studies [22–24].

The aim of this study was to demonstrate the effect of the COM height on postural sway analysis using an accelerometry based approach of an inverted pendulum and then to propose a method that allows sway comparisons across subjects with different COM heights. In the following sections, an accelerometry approach for sway path measurement, the apparatus used in the study, and the results obtained are discussed.

2. Accelerometry Based Sway Measurement

During quiet standing, human sway can be modelled using the principle of an inverted pendulum. A method for the evaluation of standstill balance is shown in Figure 1 and described using Equations (1)–(3) [25], where A is the resultant acceleration. The directional cosines of the three perpendicular acceleration vectors, a_x , a_y , and a_z , are given by $\cos(\alpha)$, $\cos(\beta)$ and $\cos(\gamma)$, respectively. The projected distance is D , and the position of the COM from the ground surface is d_z .

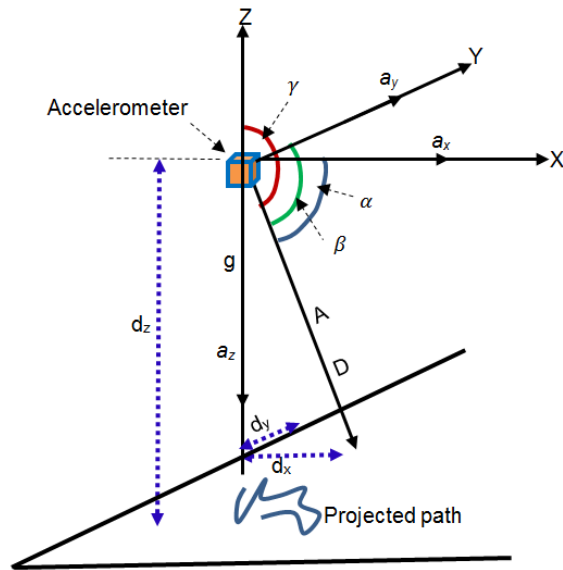

Figure 1. Tracing of the trajectory of the accelerometer on ground [25].

$$A = \sqrt{a_x^2 + a_y^2 + a_z^2} \tag{1}$$

$$\cos(\alpha) = \frac{a_x}{A}, \cos(\beta) = \frac{a_y}{A}, \cos(\gamma) = \frac{a_z}{A} \tag{2}$$

$$D = -\frac{d_z}{\cos(\gamma)}, d_x = D \cos(\alpha), d_y = D \cos(\beta) \tag{3}$$

where α , β , and γ are the angles obtained from the directional cosines. However, the inverted pendulum model can be described using Figure 2 and by Equations (4) and (5). This approach is similar to the one link model described in [26].

$$\varphi_1 = 90 - \gamma, \gamma = \alpha - 90, \varphi_1 = 180 - \alpha \tag{4}$$

$\varphi_2 = \varphi_1, \varphi_3 = \gamma$ (corresponding angles) and $\varphi_4 = \varphi_2, \varphi_5 = \varphi_3$ (alternate angles).

$$d_x = -L \cos(\alpha), d_y = -L \cos(\beta), H = L \cos(\gamma) \tag{5}$$

The angles φ_1 , φ_2 , and φ_3 and the inclined vertical height from ground (H) are defined, as indicated in Figure 2.

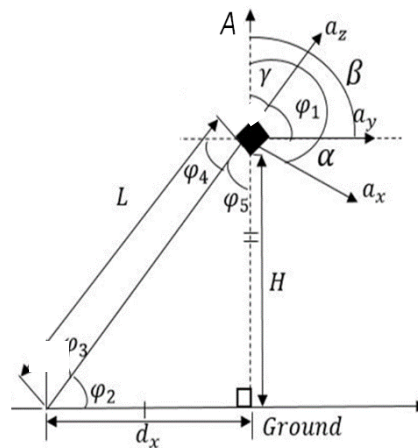

Figure 2. Sway path projection based on inverted pendulum.

3. Accelerometry Measurement Devices

The accelerometry measurement devices, developed to carry out the tests, are shown in Figure 3.

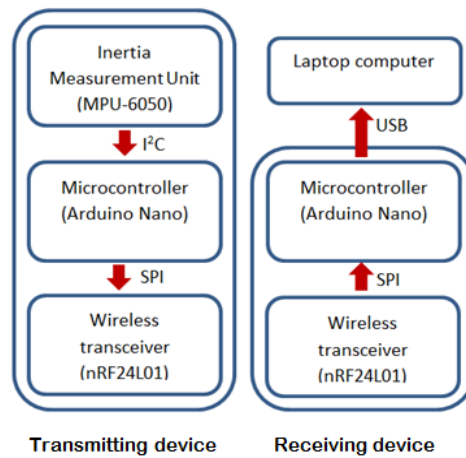

Figure 3. Accelerometry system used for the tests.

The overall system consisted of a transmitting device and a receiving device. The transmitting device measured the movements using an inertia measurement unit (accelerometer, type: MPU-6050). The measurements relate to the three perpendicular axes (X , Y , and Z) for movements. The data were sent wirelessly (by a wireless transceiver, type: nRF24L01) via a microcontroller board (type: Arduino) to the receiving device. On the receiving side, another transceiver (type: nRF24L01) received the accelerometry data and forwarded them to a laptop computer via a microcontroller board (type: Arduino). The computer then displayed the data and stored them for processing.

4. Measurement Apparatus

The apparatus used to carry out the measurements is shown in Figure 4.

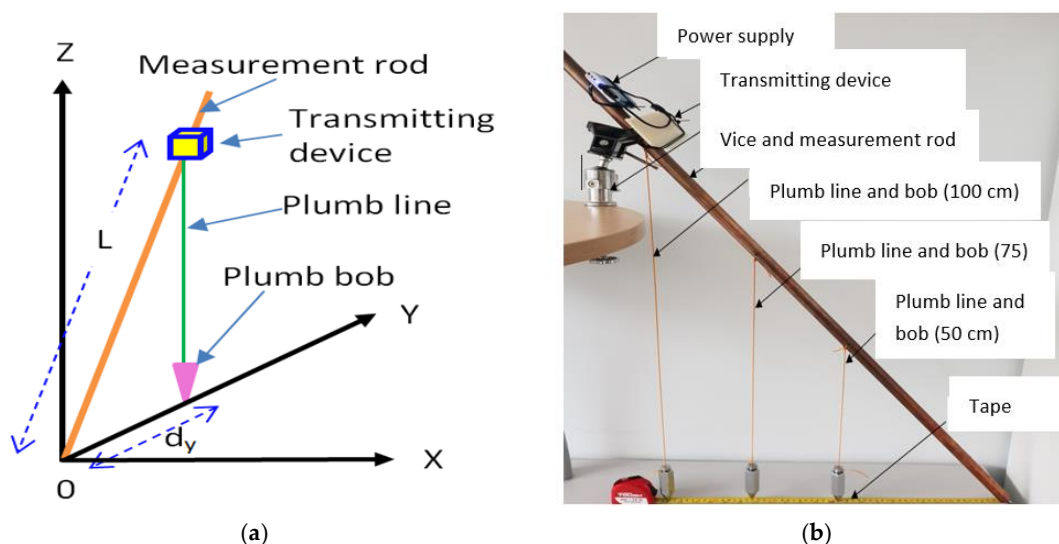

Figure 4. Test measurement apparatus (a) schematic diagram with only one of the three plumb bobs shown. (b) Actual apparatus.

The test apparatus consisted of the transmitting device (described in Section 3), attached to a measurement rod at distance $L = 100$ cm from the end of the rod. Three plumb lines-plumb bobs were attached to the measurement rod at: position 1 = 50 cm, position 2 = 75 cm, and position 3 = 100 cm, respectively, from one of its ends. The measurement rod was held by a vice that allowed it to be

inclined accurately in steps of 5 degrees from the vertical (inclination angle of 0 degree) to 90 degrees (horizontal to the ground) in the Y axis of the accelerometer. The inclination angle was determined manually with a protractor. For each angle, the position (d_y) of each plumb bob from the origin (shown as 0 in Figure 4a) was measured manually using a tape measure. Simultaneously, the acceleration data from the three axes of the accelerometer device (X , Y , and Z) were wirelessly transmitted to the receiving device (described in Section 3). The algebra described in Section 2 was used to determine accelerometry based angles and displacements, and these were compared with the manual measurements. For each inclination angle, a 1 s recording was made with a sample rate of 60 samples per second. The values were then averaged to reduce the effect of measurement noise. The software used for this purpose was Processing^(c) language. The data were analyzed using MATLAB^(c).

4.1. Data Analysis

The displacement in the Y -direction (d_y) from accelerometry was determined using equation 5 and averaged (d_{ya}) over the number of samples, N ($N = 60 \text{ s} \times 60 \text{ samples per second} = 3600 \text{ samples}$).

$$d_{ya} = \frac{1}{N} \sum_{n=1}^N d_y(n) \quad (6)$$

The inclination angle in the Y -direction (γ) from the accelerometry was determined using Equation (2) and averaged (γ_a) over the number of samples.

$$\gamma_a = \frac{1}{N} \sum_{n=1}^N \gamma(n) \quad (7)$$

Data analysis was carried out in SPSS[®] statistical package. T-test, correlation, and linear regression analysis were performed to interpret the measurements.

5. Results and Discussion

Nineteen measurements were obtained from the inclination angles of around 0 to 90 degrees at steps of around 5 degrees. The manual and accelerometry measurements are provided in Tables 1 and 2 respectively. The displacements in Table 2 corresponding to positions 1 (50 cm), 2 (75 cm), and 3 (100 cm) were determined using: $d_y = -L \cos(\beta)$, $\cos(\beta) = \frac{a_y}{A}$, and $d_y = -L \frac{a_y}{A}$, respectively.

For the manual measurements, the means (M) and standard deviations (SD) for the positions were position 1: M = 31.5 cm and SD = 16.6 cm, position 2: M = 46.9 cm and SD = 24.8 cm, and position 3: M = 62.8 cm and SD = 33.3 cm. For the accelerometry measurements, the means and standard deviations were position 1: M = 31.5 cm and SD = 16.7 cm, position 2: M = 47.2 cm and SD = 25.0 cm, and position 3: M = 62.9 cm and SD = 33.3 cm. The accelerometry and manual measurements gave close readings for all three positions.

Table 1. Manual measurements.

Measurement Number	Angle, γ (Degrees)	Position 1 (Displacements at COM = 50 cm)	Position 2 (Displacement at COM = 75 cm)	Position 3 (Displacement at COM = 100 cm)
1	0	0	0	0
2	5	5	7	9
3	10	9	13	17
4	15	12	19	25
5	20	17	25	34
6	25	21	31	42
7	30	25	36	50
8	35	29	43	56
9	40	32	50	65
10	45	35	52	70
11	50	39	58	77
12	55	41	60	82
13	60	44	65	87
14	65	45	68	90
15	70	48	70	95
16	75	48	72	97
17	80	49	73	98
18	85	49	74	99
19	90	50	75	100
		Mean = 31.5 cm	Mean = 46.9 cm	Mean = 62.8 cm
		Standard deviation = 16.6 cm	Standard deviation = 24.8 cm	Standard deviation = 33.3 cm

Table 2. Accelerometry measurements.

Measurement Number	Angle γ (Degrees)	Position 1 (Displacements at COM = 50 cm)	Position 2 (Displacement at COM = 75 cm)	Position 3 (Displacement at COM = 100 cm)
1	0.80	0.69	1.04	1.39
2	5.09	4.44	6.66	8.87
3	9.12	7.93	11.89	15.85
4	14.42	12.45	18.68	24.90
5	20.05	17.14	25.72	34.29
6	25.01	21.14	31.72	42.28
7	29.35	24.51	36.76	49.02
8	34.66	28.44	42.65	56.87
9	40.27	32.32	48.47	64.63
10	44.96	35.33	52.78	70.66
11	50.39	38.52	57.78	77.05
12	55.65	41.28	61.92	82.57
13	61.02	43.74	65.61	87.48
14	65.06	45.34	68.01	90.68
15	71.02	47.28	70.92	94.56
16	75.33	48.37	72.55	96.74
17	80.48	49.31	73.97	98.62
18	84.17	49.74	74.61	99.48
19	89.28	50.00	74.99	99.99
Statistics		Mean = 31.5 cm Standard deviation = 16.7 cm	Mean = 47.2 cm Standard deviation = 25.0 cm	Mean = 62.9 cm Standard deviation = 33.3 cm

5.1. T-Test

The Shapiro–Wilks test was used to establish whether the differences from the three measurement positions were from a normal distribution (confidence interval CI = 99%). The purpose of this test was to verify whether the COM height does affect the measured displacements. The data from each group were confirmed to be from a normal distribution ($p > 0.01$). In order to establish whether the displacements from the three positions (position 1 against 2, position 1 against 3, and position 2 against 3) were different, paired sample t-test with $\alpha = 0.01$ was used. The results of the t-test showed that significant differences existed between the measurements for the three tests. When comparing the measurement positions (1 and 2, 1 and 3, and 2 and 3), p values less than 0.01 ($p < 0.01$) were obtained. This indicated that the height of the COM can affect postural sway displacement measurements. This can have an implication when comparing the sway displacements between individuals of different COM heights using the inverted pendulum model.

5.2. Correlation and Linear Regression Analysis

To test the relationship between the three positions for the manual and accelerometry measurements, Pearson's correlation with confidence interval 99% ($\alpha = 0.01$) and linear regression were performed. For the manual measurements, there was a strong positive correlation between positions 1 and 2, $r = 0.999$; positions 1 and 3, $r = 1$; and positions 2 and 3, $r = 1$ ($p \leq 0.001$). The relationships between the positions 1 and 2, 1 and 3, and 2 and 3 are shown in Figure 5. Similarly, for accelerometry measurement there was a strong positive correlation between positions 1 and 2, $r = 1$; positions 1 and 3, $r = 1$; and positions 2 and 3, $r = 1$ ($p \leq 0.001$).

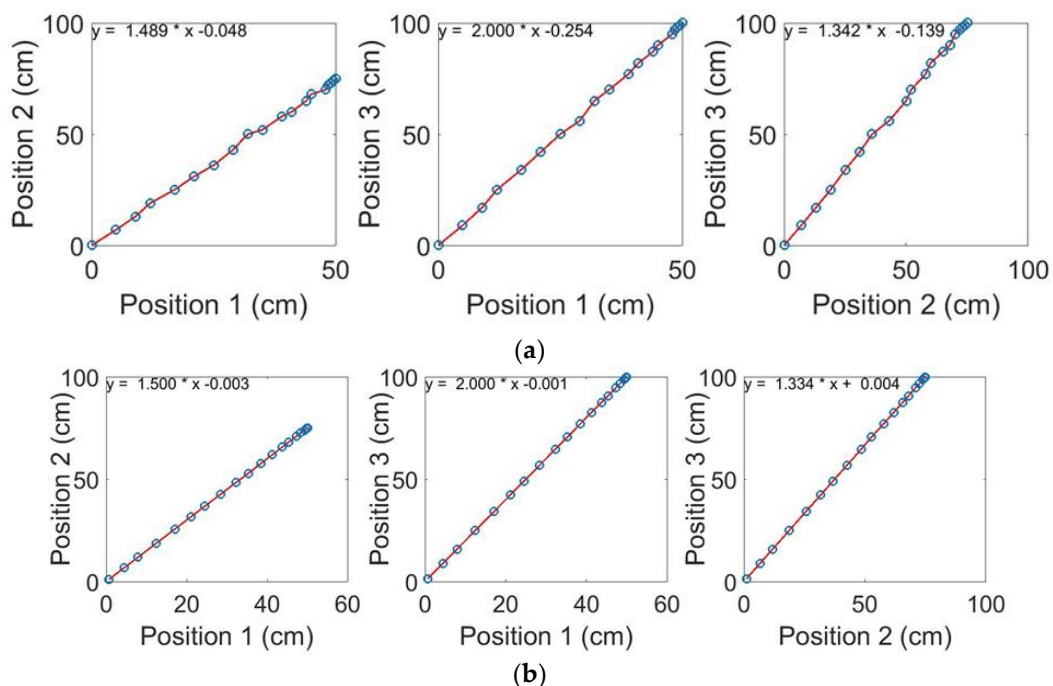

Figure 5. Relationship analysis of the three positions: (a) manual, and (b) accelerometry.

The respective gradients of the plots in Figure 5a were: 1.49, 2.00, and 1.34. For Figure 5b, the respective gradients were: 1.50, 2.00, and 1.33. The manual and accelerometry measurements have close gradients. The accelerometry results (Figure 5b) showed that the displacements value for position 2 could be obtained from displacements from position 1 using the formula: $1.5x - 0.003$ (x is horizontal axis). Similarly, from the same figure, the gradient for positions 3 versus 1 was 2.00, and for positions 3 and 2, it was 1.33. For each plot, the gradient represented the ratio of COM heights, i.e., $75/50 = 1.50$, $100/50 = 2.00$, and $100/75 = 1.33$. The implication for these results is that when performing sway analysis, a person with a higher COM would produce a greater sway displacement for the same angular movement. A difference of 25 cm between the COM for positions 1 and 2 resulted in a

gradient of 1.5, and a difference of 50 cm between the COM for position 1 and 3 resulted in a gradient of 2.0. Similarly, a difference of 25 cm between the COM for positions 2 and 3 resulted in a gradient of 1.33. This effect could introduce a bias that may affect interpretation of sway path measurements.

The box plots in Figure 6 further illustrate the relationships between the measurements associated with positions 1, 2, and 3 for both measurements of manual and accelerometry based methods. These indicate the statistics for measurement, e.g., median (horizontal bar inside each box) and interquartile range have increased as the COM height increased.

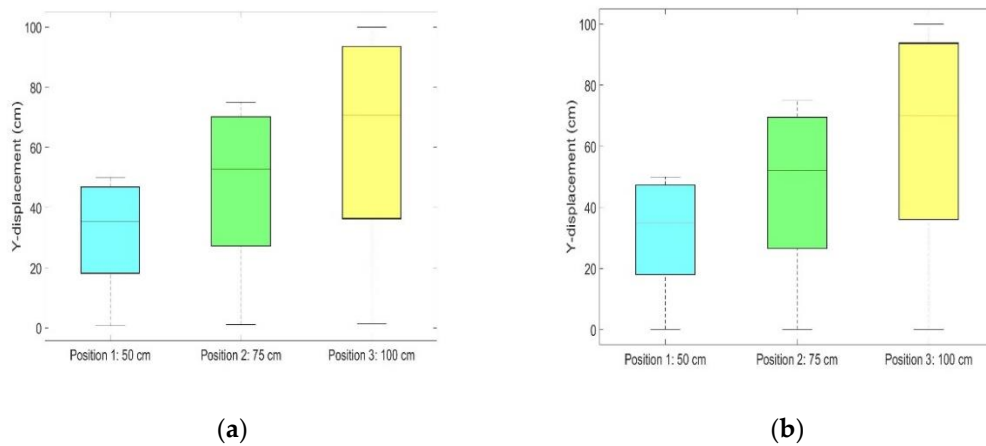

Figure 6. Box plots for (a) manual, (b) accelerometry measurements.

In order to deal with the bias introduced by the COM height, the measurements could be normalized by setting the COM height to unity for all subjects. This concept is illustrated in Figure 7, where the plots of Figure 5 were normalized by setting the value of L in equation 5 to unity for all positions. In these plots, the same displacement was produced by all three positions for a given angular inclination. The advantage of this method is that when analyzing sway path across subjects with different COM heights, the magnitude of their respective sway displacements are comparable.

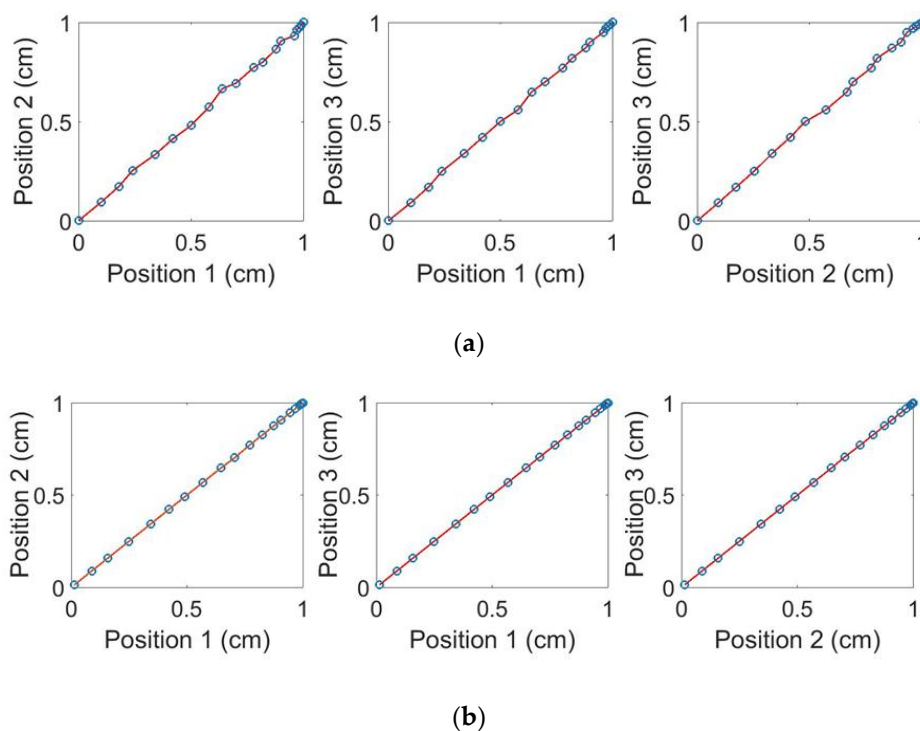

Figure 7. Normalized displacements: (a) manual and (b) accelerometry.

Figure 8 shows accelerometry based sway plots from two healthy adult subjects in a standing still test on a foam surface with eyes closed (this is one of the tests associated with the Modified Clinical Test for Sensory Interaction of Balance [16]). The unit containing the accelerometer was worn at lower back region. The plots show the ground projected displacements in the X and Y directions. For the plots in Figure 8a,b, the COM height of the subject was 105 cm, and for the plots in Figure 8c,d, the COM height was 95 cm. Figure 8a,c were obtained from when the actual COM heights (L) were used in the formulae described in Section 2, and for the plots in Figure 8b,d, L was set to 1. The magnitudes of displacements shown in normalized plots of Figures 8b,d were comparable, while for those in Figure 8a,c, their relative displacements may not be comparable owing to the bias introduced by their respective COM positions. This bias is more noticeable when comparing subjects with a large difference of COM between them, such as children and adults.

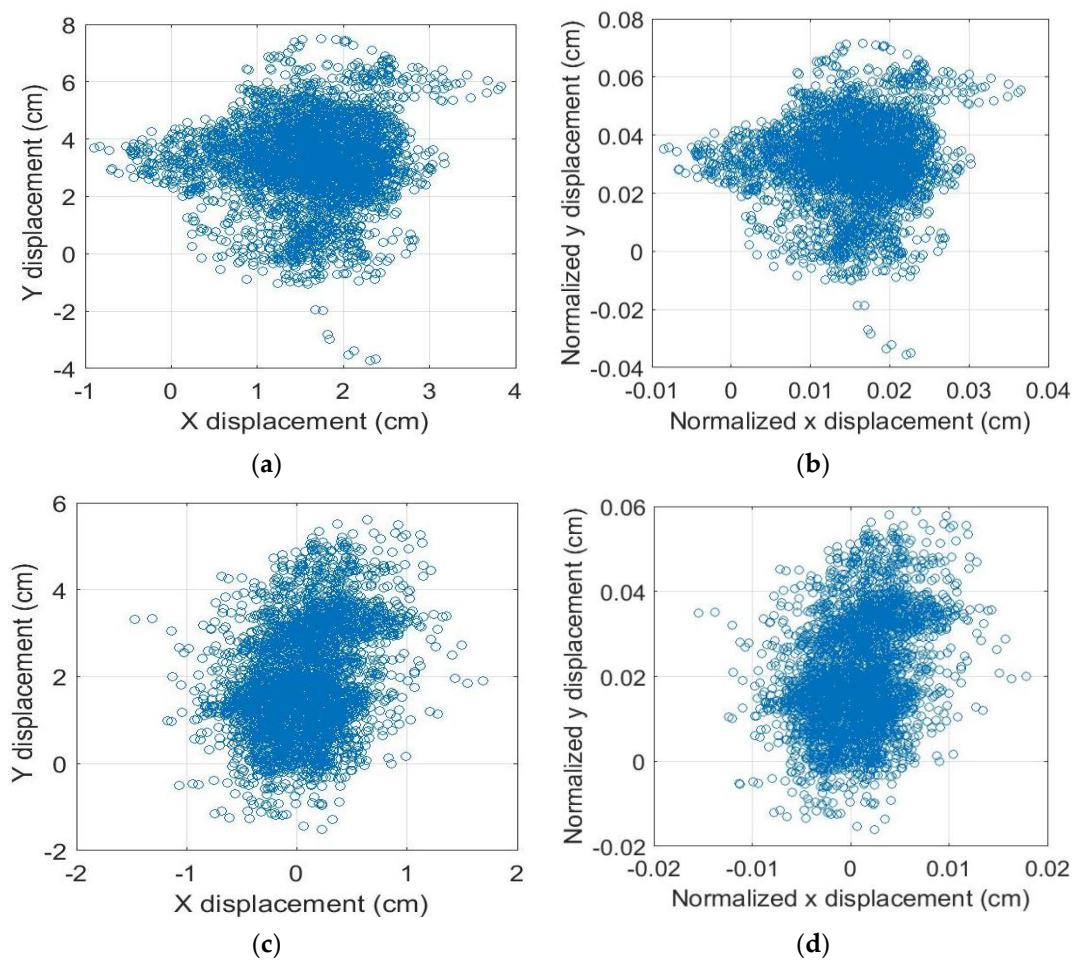

Figure 8. Sway plots from two healthy adult subjects standing on a foam surface with eyes closed. (a) The actual COM height value was used in determining the displacements. (b) COM height was set to 1 to produce a normalized sway displacement plot. (c) and (d) are as in figures (a) and (b), but for the second subject.

6. Conclusions

A test apparatus was devised to investigate the influence of center of mass (COM) height on postural sway analysis. It was observed that for a particular angle of inclination, the projected displacement on the ground surface was related to the height of the COM, i.e., the higher the COM produced, the larger projected sway displacement. This may have implications when comparing the magnitude of displacement across subjects with varying COM heights. A method that normalized the COM height was used to deal with this effect. Associated results from the test apparatus and two healthy adult subjects were used to demonstrate these issues.

Author Contributions: Conceptualization, methodology, and formal analysis by O.O.D.O. and R.S. Writing by O.O.D.O. and R.S., with contributions by M.S. All authors have read and agreed to the published version of the manuscript.

Funding: This research received no external funding.

Conflicts of Interest: The authors declare no conflict of interest.

References

1. Winter, D.; Patla, A.; Prince, F.; Ishac, M.; Gielo-Perzczak, K. Stiffness control of balance in quiet standing. *J. Neurophysiol.* **1998**, *80*, 1211–1221.
2. Lafond, D.; Duarte, M.; Prince, F. Comparison of three methods to estimate the center of mass during balance assessment. *J. Biomech.* **2004**, *37*, 1421–1426.
3. Rosker, J.; Markovic, G.; Sarabon, N. Effects of vertical center of mass redistribution on body sway parameters during quiet standing. *Gait Posture* **2011**, *33*, 452–456.
4. Shumway-Cook, A.; Horak, F. Assessing the influence of sensory interaction on balance. *Phys. Ther.* **1986**, *66*, 1548–1550.
5. Corriveau, H.; Hébert, R.; Prince, F.; Raïche, M. Postural control in the elderly: An analysis of test-retest and interrater reliability of the COP-COM variable. *Arch. Phys. Med. Rehabil.* **2001**, *82*, 80–85.
6. Hasan, S.; Robin, D.; Szurkus, D.; Ashmead, D.; Peterson, S.; Shiavi, R. Simultaneous measurement of body center of pressure and center of gravity during upright stance. Part I: Methods. *Gait Posture* **1996**, *4*, 1–10.
7. Hasan, S.; Robin, D.; Szurkus, D.; Ashmead, D.; Peterson, S.; Shiavi, R. Simultaneous measurement of body center of pressure and center of gravity during upright stance. Part II: Amplitude and frequency data. *Gait Posture* **1996**, *4*, 11–20.
8. Błaszczyk JW, Beck M, Sadowska D. Assessment of postural stability in young healthy subjects based on directional features of posturographic data: vision and gender effects. *Acta Neurobiol. Exp. (Warsaw)* **2014**, *74*, 433–442.
9. Błaszczyk JW. The use of sway vector for the assessment of postural instability. *Gait Posture* **2016**, *44*, 1–6, doi: 10.1016/j.gaitpost.2015.10.014.
10. Kavanagh, J.; Menz, H. Accelerometry: A technique for quantifying movement patterns during walking. *Gait Posture* **2008**, *28*, 1–15.
11. Yang, C.; Hsu, Y. A Review of Accelerometry-Based wearable motion detectors for physical activity monitoring. *Sensors* **2010**, *10*, 7772–7788.
12. Mathie, M., Coster, A., Lovell, N. and Celler, B. Accelerometry: providing an integrated, practical method for long-term, ambulatory monitoring of human movement. *Physiol. Meas.* **2004**, *25*, R1–R20.
13. Oshima, Y.; Kawaguchi, K.; Tanaka, S.; Ohkawara, K.; Hikiyama, Y.; Ishikawa-Takata, K.; Tabata, I. Classifying household and locomotive activities using a triaxial accelerometer. *Gait Posture* **2010**, *31*, 370–374.
14. Khan, A.; Hammerla, N.; Mellor, S.; Plötz, T. Optimising sampling rates for accelerometer-based human activity recognition. *Pattern Recognition Letters* **2016**, *73*, 33–40.
15. Chien, J.C.; Hirakawa, K.; Shieh J.; Guo, H.W.; Hsieh, Y. A simple method for walking posture analysis using accelerometers," In Proceedings of the 2016 International Conference on Communication Problem-Solving (ICCP), Taipei, Taiwan, 7–9 September 2016; pp. 1–3.
16. Cohen, H.; Blatchly, C.A.; Gombash, L.L. A study of clinical test of sensory interaction and balance. *Phys. Ther.* **1993**, *73*, 346–351.
17. Martínez-Ramírez, A.; Lecumberri, P.; Gómez, M.; Rodríguez-Mañas, L.; García, F.; Izquierdo, M. Frailty assessment based on wavelet analysis during quiet standing balance test. *J. Biomech.* **2011**, *44*, 2213–2220.
18. Mancini, M.; Salarian, A.; Carlson-Kuhta, P.; Zampieri, C.; King, L.; Chiari, L.; Horak, F. iSway: a sensitive, valid and reliable measure of postural control. *J. Neuroeng. Rehabil.* **2012**, *9*, 1–8.
19. Spain, R.; St. George, R.; Salarian, A.; Mancini, M.; Wagner, J.; Horak, F.; Bourdette, D. Body-worn motion sensors detect balance and gait deficits in people with multiple sclerosis who have normal walking speed. *Gait Posture* **2012**, *35*, 573–578.
20. Gago, M.; Fernandes, V.; Ferreira, J.; Silva, H.; Rocha, L.; Bicho, E.; Sousa, N. Postural stability analysis with inertial measurement units in Alzheimer's disease. *Dement. Geriatr. Cogn. Disord. Extra* **2014**, *4*, 22–30.

21. Goldring, D.; Londe, S.; Sivakoff, M.; Hernandez, A.; Britton, C.; Choi, S. Blood pressure in a high school population. *J. Pediatrics* **1977**, *91*, 884–889.
22. Alberts, J.; Hirsch, J.; Koop, M.; Schindler, D.; Kana, D.; Linder, S.; Campbell, S.; Thota, A. Using accelerometer and gyroscopic measures to quantify postural stability. *J. Athl. Train.* **2015**, *50*, 578–588.
23. Hiiragi, Y. (2004). Evaluation of postural sway using a triaxial accelerometer. *Rigakuryoho Kagaku* **2004**, *19*, 305–309.
24. Marvel, C.A. quantitative measure of postural sway deficits in schizophrenia. *Schizophr. Res.* **2004**, *68*, 363–372.
25. Mayagoitia, R.; Lötters, J.; Veltink, P.; Hermens, H. Standing balance evaluation using a triaxial accelerometer. *Gait Posture* **2002**, *16*, 55–59.
26. Najafi, B.; Lee-Eng, J.; Wrobel, J.S.; Goebel, R. Estimation of center of mass trajectory using wearable sensors during golf swing. *J. Sports Sci. Med.* **2015**, *14*, 354–363.



© 2020 by the authors. Licensee MDPI, Basel, Switzerland. This article is an open access article distributed under the terms and conditions of the Creative Commons Attribution (CC BY) license (<http://creativecommons.org/licenses/by/4.0/>).