

Innovative acoustic jacketing for oil and gas pipelines

MOHAMMAD, Kashif, ASTHANA, Abhishek, COCKERHAM, Graham and ALMOND, Mark

Available from Sheffield Hallam University Research Archive (SHURA) at:

<http://shura.shu.ac.uk/26072/>

This document is the author deposited version. You are advised to consult the publisher's version if you wish to cite from it.

Published version

MOHAMMAD, Kashif, ASTHANA, Abhishek, COCKERHAM, Graham and ALMOND, Mark (2016). Innovative acoustic jacketing for oil and gas pipelines. In: 6th World PetroCoal Congress, New Delhi, India, 15-17 Feb 2016. (Unpublished)

Copyright and re-use policy

See <http://shura.shu.ac.uk/information.html>

Innovative Acoustic Jacketing For Oil And Gas Pipelines

Kashif R. Mohammad, Abhishek Asthana* and Sanjay Mukherjee

Sheffield Hallam University, Sheffield, S1 1WB, United Kingdom

Tel. +44 114 225 3261, *Email: a.asthana@shu.ac.uk

Abstract

Oil and Gas Pipelines need thermal insulation and cladding to protect them from harsh environmental conditions, prevent heat losses, minimise health and safety risks and comply with legislation. In certain areas, these cladding jackets require additional layers of noise and vibration insulation and often the installation process is expensive and labour intensive. Conventional systems use products like Lead and Bitumen for noise reduction, but their use causes health, safety and environmental problems. This research aimed to mitigate these health and environmental problems and produce an economic solution for noise insulation and jacketing. Using a series of experimental tests and Finite Element Analysis (FEA), an integrated cladding system has been developed, combining acoustic insulation and metal sheets in a single product. These tests showed that the new system improved acoustic performance and corrosion prevention while simultaneously allowing easier installation which significantly reduces installation time and related costs. A special purpose machine has also been developed which will produce the product in an efficient and cost effective manner.

1. Introduction

There are 2 basic types of oil and gas pipelines – transporting crude oil and Liquefied Natural Gas (LNG). The usual temperature for transporting crude oil varies between 120 – 130 °C and any heat loss to the atmosphere could result in wax formation and an increase in the fluid viscosity. The wax deposition on the inner walls of the pipelines poses an expensive problem as it causes large pressure drops and significantly increases the pumping costs or requires more frequent reheating especially in long pipelines in cold climatic conditions. In extreme cases it can even lead to the loss of the pipeline as the pipeline become completely blocked due to wax deposition on its walls (Ararimeh Ayeina et. al.).

The transport of natural gas as LNG (liquefied at -162 °C and transported at -170 °C) requires cryogenic pipelines with adequate insulation and protective features. Heat gained by the LNG from the atmosphere can boil the LNG which leads to a 600 fold increase in its specific. This exerts immense pressure on the walls of the pipeline and can cause serious explosions. Therefore, an efficient insulation is imperative for both these systems to ensure a safe operation.

The oil and gas processing plant involves refining, refrigeration, compression and pumping equipment that generates excessive levels of noise which, if exceeds the allowable limit set by the regulating authorities, is considered as a health, safety and environmental hazard. These equipment needs to be properly insulated to protect the employees and contractors working in the plant. This research investigates the current insulation systems to identify their shortcoming and look to develop new products and processes to improve current systems.

2. Literature Review

Current Insulation System

The safety records for the oil and gas transmission pipelines is generally very good in maintaining the condition of the fluid in the pipelines and personnel protection. However, it brings along with it, some challenges that would not otherwise be present for bare pipelines. The most common cause of the failure of these pipelines within the oil & gas and chemical industries is corrosion under insulation (CUI). CUI is the localised corrosion of the pipeline or equipment under the insulation system. This can result in sudden leak which may cause fire or explosion to endanger personnel safety and loss of production volume can cause significant economic losses. CUI is caused when the condensed moisture and rain water ingress in the insulated pipelines and are absorbed and retained by the insulation material creating conditions conducive for galvanic, crevice, stress cracking and pitting corrosion. As CUI occurs under the cladding system, it is undetectable in standard inspection procedure; this makes it even more challenging problem to identify and address.

Current insulation systems include a layer of low thermal conductivity insulation material wrapped around the pipeline. This can be a mineral fibre blanket, cellular glass, elastomeric foam or calcium silicate insulation block. The thickness and the number of layers depend on the location and the type of fluid flowing through pipeline. The insulation material is further wrapped up by a vapour barrier to prevent any moisture ingress in the system, this may be a butyl wrap or aluminium foil. The metal cladding is used over the vapour barrier to secure the entire insulation system. To prevent any dissimilar metal contact, the metal cladding is generally laminated with a moisture barrier or painted to prevent direct contact or the cladding with the vapour barrier (ASTM F683 – 14) (Piping Handbook: Mohinder L Nayyar).

For acoustic applications, the insulation material used is a porous layer of mineral fibre or any other open cell foam. This is then wrapped around with a high density viscoelastic material as an acoustic barrier before the metal cladding. Most popular material for this application are lead and bitumen. Though these materials are very effective for acoustic insulation however when subjected to high temperature these

materials emit carcinogenic aromatic compounds which pose high risk to health, personal safety and environment. Currently, ISO 15665 is used throughout the industry for the acoustic insulation of pipelines (ISO 15665).

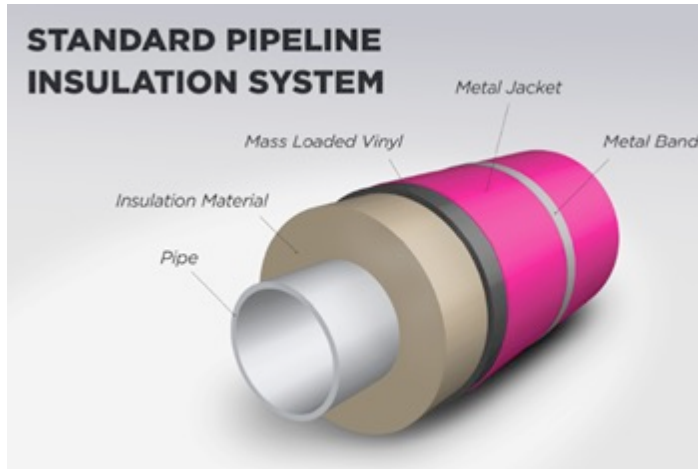

Figure 1: Standard pipeline insulation system

A thorough market research and interviews with the pre-FEED, FEED and insulation contractors was conducted. We learned that the insulation systems are installed on the site by insulation contractors, where sheet metal workers are responsible for physically installing each layer of insulation. This is a very time and labour intensive process. It becomes a big commercial challenge for contractors based in countries where the labour rates are very high. The labour rates can go up to \$ 150 – 190/hour for a skilled sheet metal worker. The insulation contractors employ methods to reduce the labour dependency and reduce time in installation at assembly level.

Preformed insulation material sections: The insulation material sections are preformed according to the size of the pipe in the workshops before being shipped to the sites. This allows faster installation of the insulation material

Modular section of pipelines: Modular sections of pipelines are manufactured in locations with low labour cost like China and Middle East, these sections are then transported to the location of the plant. On-site these are assembled as a giant jigsaw puzzle. Though, these methods help in reducing the installation time of the pipelines a large amount of work is still required on the site to install these sections. Insulation of a typical 10 inch. pipeline with a 100mm layer of insulation material with acoustic barrier and metal jacketing takes around 1.3 hours (from UK insulation contractor sources).

As no method is available to help in the reduction of the labour cost at manufacturing stage, the research is focused on exploring this opportunity and developing a commercially viable method to reduce the labour cost at the manufacturing stage. The research also looked into viable replacements of materials like lead and bitumen to improve the acoustic properties while reducing the environmental impact of the systems.

3. Methodology

3.1 Material Analysis

After much research in the sound damping materials, it was identified that poly vinyl chloride (PVC) when loaded with minerals like barium sulphate can form a limp mass viscoelastic material with a density of 2.5 k/m² and performs exceptionally well as an acoustic barrier. To verify the claim, we conducted a test at Salford University, the procedure adopted were that detailed in BS EN ISO 10140 Part 2: 2010, “Acoustics – Laboratory Measurement of sound insulation of building elements; Part 2: Measurement of airborne sound insulation”. The test involved producing a known sound field in the source room and measuring the resultant sound level difference between the source room and the receiving room with the specimen installed in the test aperture. This level difference was then corrected so as to take into account the equivalent absorption area of the receiving room. The sound reduction index, R (dB), is defined in BS EN ISO 10140 – Part 2:2010 as:

$$R =$$

$$L_1 - L_2 + 10 \log_{10} \frac{S}{A}$$

(Equation 1)

Where:

L_1 is the average sound pressure level in the room (dB)
 L_2 is the average sound pressure level in receiving room (dB)

S is the area of the test specimen (m²)

A is the equivalent absorption area of the receiving room (m²)

The correction term of equation (I) containing the equivalent absorption area, A , was evaluated from the reverberation time and calculated using Sabine’s Formula:

$$A = \frac{0.16 V}{T}$$

(Equation 2)

Where V is the volume of the receiving room (m³) and T is the reverberation time in seconds.

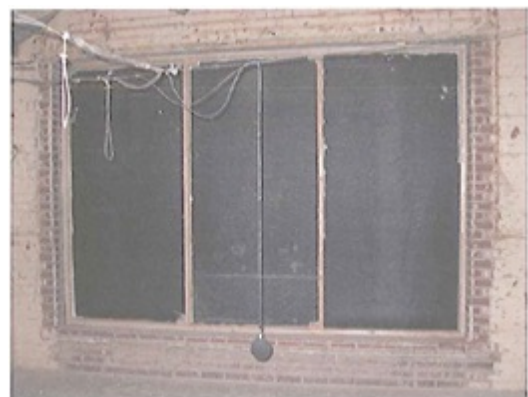

Figure 2: Test setup

3.2 Economic considerations

We proposed the bonding of the vinyl with the metal jacket as this would integrate the installation process of the vinyl and the jacket into a single acoustic damping laminate. Developing a single laminate would allow significant benefits to the system as it would allow quicker application to achieve significant time and cost savings. The layer of vinyl will also act as a moisture barrier on the underside of the vinyl isolating the metal jacket from the rest of the insulation system to and thereby prevent corrosion of the metal jacket. The main challenges the bonding could pose was to achieve a strong bond between the material using an industrial adhesive. This is because any delamination between the layers would allow space for moisture ingress, which would lead to corrosion of the metal jacket.

3.3 Bonding MLV to Metal

Once the acoustic barrier was developed, the research then focused on the development of the process to laminate the MLV to metal. The main challenge encountered was that the vinyl was heavily plasticised and therefore most heat activated and pressure sensitive adhesives were not successful in sustaining a long term strong bond and failed the ageing tests. In collaboration with the vinyl manufacturers, we developed a special plasticizer resistant heat activated adhesive mesh which could allowed an improved bond between the vinyl and the metal.

3.4 Comparing new sound damping laminate to conventional system

A standard test procedure exists for the evaluation of pipe cladding systems (ISO 15665:2003, Acoustics — Acoustic insulation for pipes, valves and flanges) and ideally this test procedure would be used to compare the acoustic performance of sound damping metal laminate to the standard construction. However, due to the budget limitations it was preferred to perform an indicative test taking guidance from ISO 15665:2003 with a view to conducting the ISO standard test at a later stage.

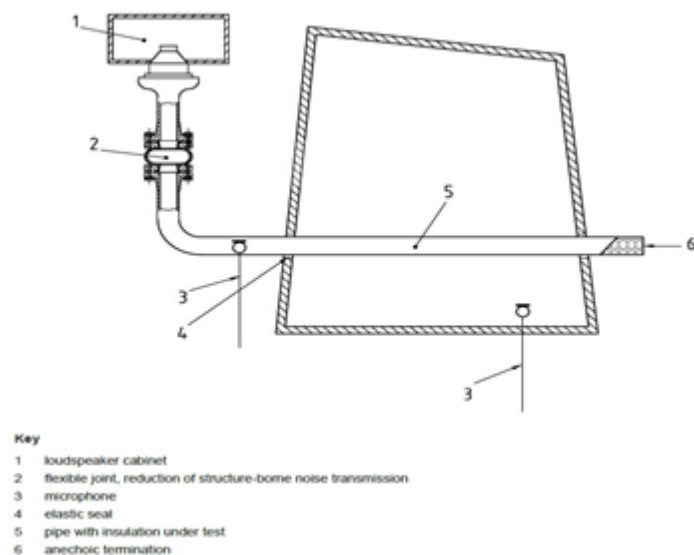

Figure 3: ISO 15665 test arrangement for the measurement of sound insertion loss using a reverberation chamber

We developed two identical prototype pipe section which were insulated with fibre glass insulation material and cladded using different cladding methods. One prototype was cladded using the sound damping metal laminate developed through this research and the other using standard configuration of cladding. In this report the acoustic performance of the newly developed bonded product is compared to what shall be referred to as the “standard construction” where the damping layer and cladding metal are applied separately.

Test Method & Setup

As highlighted in the previous section the ISO 15665 test method employs a pipe system installed into a reverberation chamber through its wall as shown in Figure 4. The alternative method employed for the test was in keeping with this but instead a vibration shaker was used to excite the pipe internally. This was done to avoid the requirement to cut through the chamber walls and to allow a shorter length of pipe for the purposes of an indicative test.

Photographs of the test setup are provided in Figure 2 and Figure 3. Five microphone were used to determine the average sound pressure in the reverberation chamber before and after cladding the pipe. A shaker mounted inside the pipe was used as the method for pipe excitation instead of a loudspeaker, see Figure 4.



Figure 4: Vibration shaker mounted inside the pipe

In order to avoid any sound radiation from the pipes interior to the room the pipe ends were sealed with steel end caps with expanding rubber seals after installation of the shaker.

3.5 FEA Analysis

After the successful experimental analysis, we created an FEA model to simulate the heat flow with the vinyl inserted in the insulation system. The test used ANSYS as the modelling and simulation tool for steady state heat flow through the layers of the pipeline insulation system.

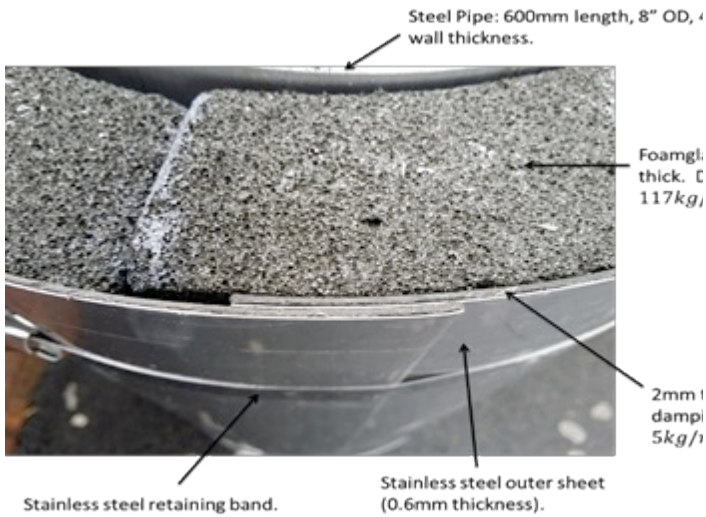

Figure 5: Shows a cross section of the pipe cladding

4. Results and Discussions

4.1 BS EN ISO 10140: International Standard for measurement of airborne sound insulation on building element

The graph below shows the sound reduction index from the test for 5kg/m² (2mm) thick barrier) compared with the standard reduction index. The performance of the MLV considerably exceeds the specified performance according to the standard.

Frequency f [Hz]	R 1/3 octave [dB]
50	--
63	--
80	--
100	13.9
125	13.8
160	14.4
200	14.6
250	16.4
315	17.9
400	19.1
500	21.0
630	22.4
800	24.3
1000	25.6
1250	27.7
1600	29.4
2000	31.5
2500	33.4
3150	35.4
4000	38.0
5000	39.1

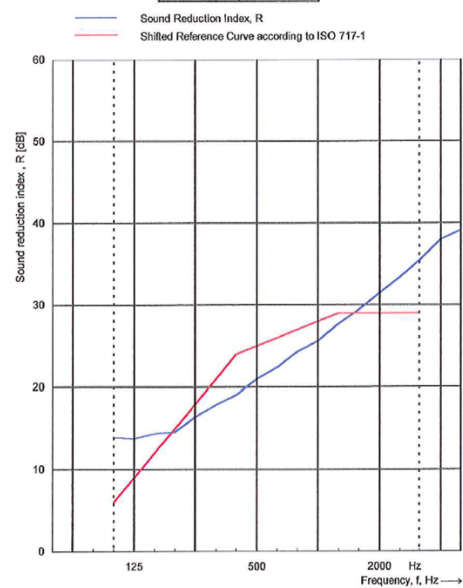

Rating according to BS EN ISO 717-1			
$R_w(C; C_2) = 25 (0 ; -3)$ dB	$C_{20-3150} = --$ dB	$C_{50-5000} = --$ dB	$C_{100-5000} = 1$ dB
Evaluation based on laboratory measurement results obtained in one-third-octave bands by an engineering method.			
$C_{2,20-3150} = --$ dB	$C_{2,50-5000} = --$ dB	$C_{2,100-5000} = -3$ dB	

Figure 6: Test Results

As the research aimed at proposing a replacement for Lead for acoustic damping in the insulation system, we compared the performance of MLV to lead in a similar test.

4.2 ISO 15665: Acoustics – Acoustic insulation for pipes, valves and flanges

- **Standard** – Glass Fibre + mass loaded vinyl + stainless steel (**vinyl/steel un-bonded**)
- **New Laminate** – Glass Fibre + mass loaded vinyl + stainless steel (**vinyl/steel bonded**)

A comparison of the sound insertion loss for the above two scenarios is provided in Figure 7.

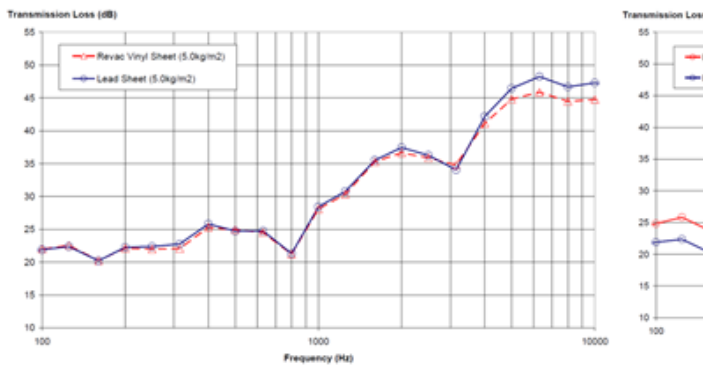

Figure 7: Comparison between MLV and Lead Sheet for acoustic insulation

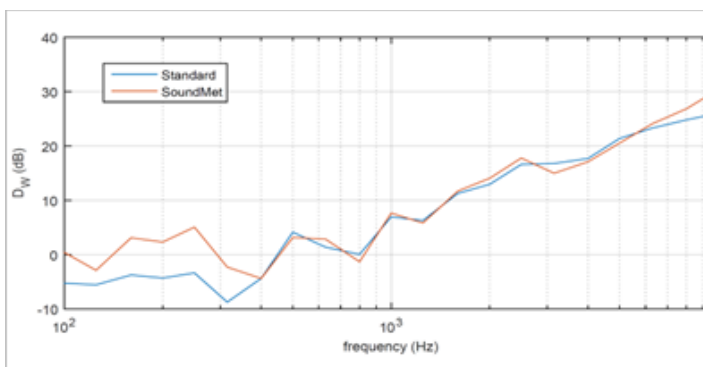

Figure 8: Comparison of the sound insertion loss of the standard pipe cladding system and the new proposed system

The aim of the test was to compare the new sound damping metal laminate which is a combination of metal bonded to a vinyl damping layer, to the standard alternative which consists of the same materials but not bonded together. The results of the testing show that the new laminate product performs at least as well as the standard construction as might be expected giving their similarity. The test results also suggest that New laminate may reduce sound amplification at low frequencies (seen as negative sound insertion loss in Figure 7) when compared to the standard product. This is feasible because bonding the vinyl layer to the stainless steel sheet can only be expected to improve coupling between the materials. If this were to be verified by the ISO 15665 test it would represent a marked improvement with respect to the standard unbonded product. There is also a potential benefit of the new product over the standard construction because it should be easier to ensure a good seal between the vinyl and stainless steel layers where they overlap at the seam. This can form an airtight seal preventing any moisture ingress into the system and thereby, mitigating corrosion under insulation (CUI).

4.3 FEA Analysis

The FEA analysis of the insulation system for a hypothetical fluid at 250 °C flowing through the pipe suggests that with adding a layer of 5kg/m² MLV to a 100mm thick layer of glass fibre insulation system, the surface temperature of the metal jacket is around 63.3

°C. This number is close to the allowable limit of 60 °C in most pipeline insulation specifications.

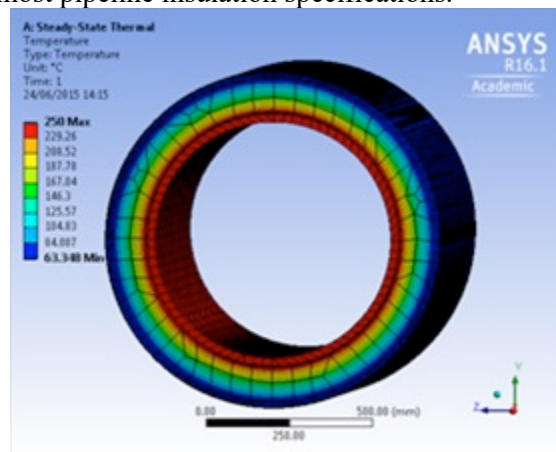

Figure 8: FEA analysis for heat transfer through the layers of pipeline insulation

5. Conclusion

A sound damping laminate for oil and gas pipeline jacketing was developed through the research. The research has successfully proposed Mass Loaded Vinyl as an alternative to lead for acoustic damping applications. Therefore, minimising health, safety and environmental impact of the insulation system. The integrated sound damping laminate also helps in the time savings and reduces labour cost as the installation of two separate components have been integrated into one. This is a significant advantage in market where the labour cost is very high.

The test conducted as per the guidance from ISO 15665 has also indicated that the new system improves the acoustic damping of the insulation system, especially for low frequency sound. Metal vinyl interface at the jacket overlaps form a stronger seal to prevent any moisture ingress into the system improving corrosion resistance properties of the system to allow longer life expectancy. The FEA analysis conducted to simulate the heat transfer through the layers of acoustic insulation shows that the MLV does not have any negative impact on the insulation system and therefore, is compatible with the current insulation systems and performs same as the conventional metal jacket.

References

1. ISO 15665:2003 “Acoustics – Acoustic insulation for pipes, valves and flanges”
2. Cowling, J and Sonnier, S. “Can you hear me now? The necessity for Noise Control in LNG Liquefaction Plants”, Gastech 2015, 27 – 30 October 2015
3. ISO 12241:2008 “Thermal insulation for building equipment and industrial installations – Calculation rules”
4. Auyejina, A. et al, 2011. “Wax formation in oil pipelines: A critical review”, Institute journal of multiphase flow 37, 671 – 694

5. Vianello, C and Maschio, G. "Risk Analysis of Natural Gas Pipeline: Case Study of Generic Pipeline", Università di Padova, DIPIC – Dip. Di Principi e Impianti Chimica Via Marzolo 9, Italy
6. Nalli, K. 2012, "Corrosion and its mitigation in the oil and gas industries, John Wiley & Sons, Inc.
7. Swift, M. 2013, "Acoustic Treatment of Industrial Process Pipelines with FEF Materials"
8. BS 5422:2009 "Method of specifying thermal insulating materials for pipes, tanks, vessels, ductwork and equipment operating within the temperature range – 40 °C to +700 °C"
9. Arai, M, et al. 2012, "Natural gas storage and transportation", 18th International ship and offshore structures congress, 09 – 13 September, 2012
10. Price. M. S and Smith. R. D, "Sources and remedies of high frequency piping vibration and noise"
11. CINI – International standard for industrial Insulation, Manual
12. BS EN ISO 10140 – 2:2010 – "International Standard for measurement of airborne sound insulation on building element"