

Monitoring Concept Study for Aerospace Power Gear Box Drive Train

Conference Proceedings

Dr.-Ing. **Sebastian Nowoisky**, Rolls-Royce Deutschland Ltd & Co KG, Dahlewitz

M. Sc. **Mateusz Grzeszkowski**, Technische Universität Berlin, Berlin

M. Sc. **Noushin Mokhtari**, Technische Universität Berlin, Berlin

Dr. **Jonathan G. Pelham**, Cranfield University, Cranfield

Prof. **Clemens Gühmann**, Technische Universität Berlin, Berlin

Abstract

Using a gearbox in a turbojet engine implies additional monitoring tasks due to new introduced failure modes. This paper outlines monitoring options to address technical diagnosis of the world's most powerful aerospace gearbox. For this novel technology different monitoring options are assessed to enable the trade between technical effort and monitoring capability.

In this paper options to monitor the gears and journal bearings are described. To detect gear wear, pitting, and gear teeth cracks the use of acceleration, acoustic emission sensors, and different methods will be assessed. First stage results are based on Back2Back test run results in occurring pitting and gear teeth loss [1].

The journal bearing mixed friction will be detected by the use of an acoustic emission sensor [3], [5]. Due to the location of the journal bearing in the rotating area of the gearbox a Wireless Data Transfer Unit (WDTU) must be introduced [6], [7]. Results of early subscale component test runs are used to define requirements to adjust the WDTU and accommodate the new power gearbox (PGB) requirements. The electronics of the WDTU must cope with challenges such as the environmental conditions of the gearbox. To extract the mixed friction pattern by the applied signal processing steps from the noise disturbance caused by gear mesh is a technical challenge.

Finally the paper closes with a recommendation on how to monitor such a gearbox and provides an outlook to the next test campaign, where the WDTU will be applied based on a back2back configuration of a subscale planetary gearbox [8].

1. Introduction

Rolls-Royce is pioneering the UltraFan^{®1} engine family architecture containing a PGB in a power range of 15 to 80 megawatt [12]. The new engine architecture must be more economical than the existing Trent engine family. The consumption of fuel is around 25 percent less than on a Trent 700 power plant [13]. To increase the efficiency of the UltraFan[®] a planetary gearbox is introduced between fan and intermediate pressure compressor. This enables to run the turbine to rotate faster and allows a reduced fan speed. Subsequently the bypass ratio will be increased and the emitted noise level decreased. To build up monitoring capability for the novel gear technology is essential to enable additional digital services as a part of the Rolls-Royce digital strategy [4].

The PGB is designed as a planetary gearbox, the gear ratio is used to reduce the fan speed, and will be able to transfer 100000 hp [14]. In 2017 in the test facility in Dahlewitz during a test run 70000 hp was transferred by the PGB and marks a record power level [11]. Due to heavy loads and high operation hours, hydrodynamic journal bearings are going to be integrated [2]. Hydrodynamic journal bearings offer advantages over roller bearings for high rotational speeds, impact loading or heavy oscillations, and vibrations.

Using a gearbox in a turbojet engine introduces additional failure modes such as gear wear, pitting, and gear teeth cracks [1]. The rotor synchronous resampling method is the state of the art for gearbox vibration monitoring and serves to reduce noise significantly. A more advanced wavelet analysis is compared with conventional order analysis or time domain feature extraction. Acoustic emission signals as well as acceleration signals are subjected to these methods. A trade between methods and signals is made to facilitate the selection of a suitable gear monitoring system.

Power Gear Box (PGB) integrated journal bearings are in focus of this research activity. The presented method allows the monitoring of journal bearing mixed friction events in a planetary gearbox [2], [3]. The drawback on the previously presented method used with a subscale journal bearing rig application is that it depends on a measurement position close to the bearing. Therefore a WDTU is essential to transfer the acoustic emission signal acquired close to the journal bearing across the rotating carrier to the stationary part of the gearbox.

In this paper methods and opportunities will be presented to detect journal bearing mixed friction as well as how to transfer the data from the rotating to the static part of the gearbox. A mockup was built to support appropriate testing of the WDTU prior the test on a subscale

¹ UltraFan[®] is a registered trade mark owned by RR plc

gearbox being carried out.

2. Gear Monitoring on PGB

An evaluation of the PGB system design process resulted in the requirement to monitor the gear train to detect possible gear failures such as gear wear, pitting and gear teeth cracks. Depending on the gear failure, several physical measurands like acoustic emission (AE), acceleration, oil particles, and temperature can be measured. However, further investigations have shown that AE and acceleration sensors are best suited for early fault detection in the case of the above-mentioned failures due to their short response time to propagating faults.

2.1 Planet-passing monitoring method

Since the vibration signals in the gear train have a vibration periodicity with respect to the gear meshing patterns, the following signal processing method for gear monitoring is shown in Figure 1 using acceleration signals. The acceleration signals were recorded on the planetary test bench of the FZG of the TU Munich [8].

The presented method aims primarily at the detection of locally distributed failures on the planet gears and the sun gear. The main idea is to monitor the vibrations of the meshing tooth of each planet gear separately to detect anomalies in the vibration patterns when faulty teeth are in contact. First, the time-dependent vibration signal, which can consist of acceleration sensor and AE sensor signals, is merged with the carrier speed sensor and transferred to the angle-domain using speed-synchronous resampling. This signal processing step reduces the smearing effect in the spectral representation, which can be caused by speed fluctuations. The low-frequency (LF) vibration signal in the upper right corner of Figure 1 shows the amplitude modulation effect that results in an increased vibration amplitude when a planet gear is directly below the vibration sensor mounted on the ring gear. After the resampling method, the vibration data are windowed with a window width of $360^\circ/N_p$, where N_p is the number of planet gears of the planetary gear. The center of the window is at the carrier angle point, if a planet gear intermeshes right near to the vibration sensor. In the preprocessing step, various filters such as low-pass filters, gear mesh band-stop filters for revealing the vibration sidebands, and high-pass filters are applied to the window-shaped vibration signals to feed the feature extraction methods in the last step of Figure 1. Afterwards, features are extracted from the angle-domain vibration signal (e.g.: root mean square (RMS), kurtosis, crest factor) and from the order-domain of the vibration signal (e.g.: FM0, FM4, NB4, NA4, sideband level factor) [24].

In addition to the method presented, non-resampled vibration signals are also windowed in the time-domain and used for preprocessing and feature extraction to allow a detection of abnormal vibration characteristics in the vibration signals that occur throughout the gear train due to gear failures.

Further tests on the FZG planetary gearbox [8] are planned this year to evaluate the method presented for monitoring the planetary gear train.

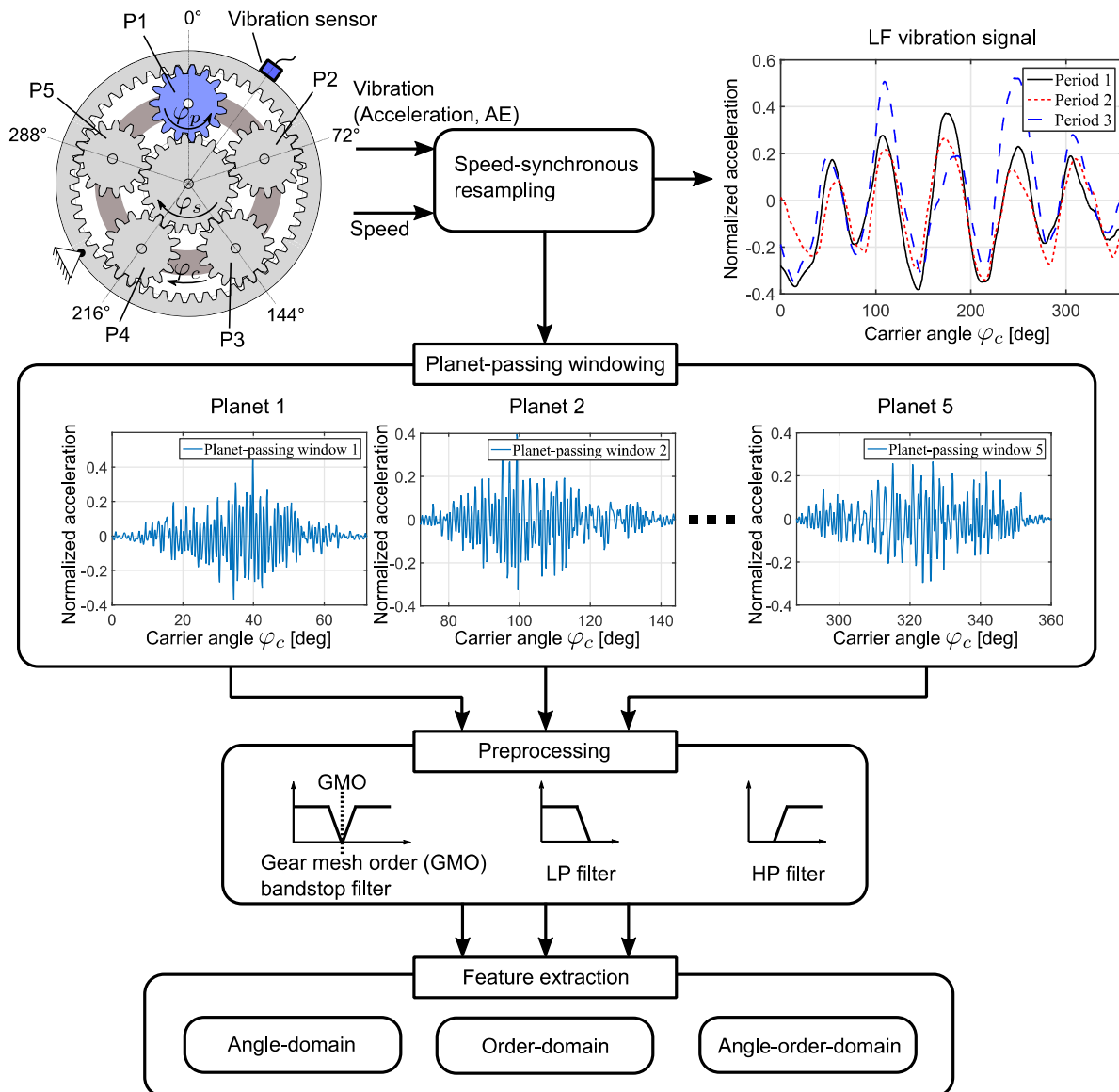

Figure 1: PGB Monitoring method

2.2 Pitting Detection

The method presented above was developed to enable gear failure detection in a planetary

gearbox. However, since one of the main gear failures, apart from tooth wear and gear teeth cracks, is macro-pitting, a failure specific investigation must be conducted to provoke pitting. Therefore, the following section presents a pitting detection method, which was evaluated with the help of load-carrying capacity tests on a back-to-back (B2B) test bench.

The test rig used is standardized to DIN ISO 14635 [20] and consists of a power circuit consisting in particular of test gears, a drive gearbox, a torsional shaft and a coupling, see Figure 2. Five different gear variants with respect to their macro geometries such as pitch deviations and flank roughness as well as their final manufacturing step were investigated to demonstrate the robustness of the pitting detection methods [1]. After a defined running-in phase, the pitting tests were carried out with a constant load of 950 Nm and an engine speed of 2400 min⁻¹.

Since the formation of pitting on the tooth flank leads to a disturbed vibration characteristic with periodic loading of the spur gears, vibration sensors were used, see Figure 2. Two identical piezoelectric acceleration sensors were placed on the bearing shell of the test gears to measure the radial accelerations resulting from locally distributed vibration. In addition, one piezo ceramic acoustic emission sensor (AE) was also mounted on the bearing shell.

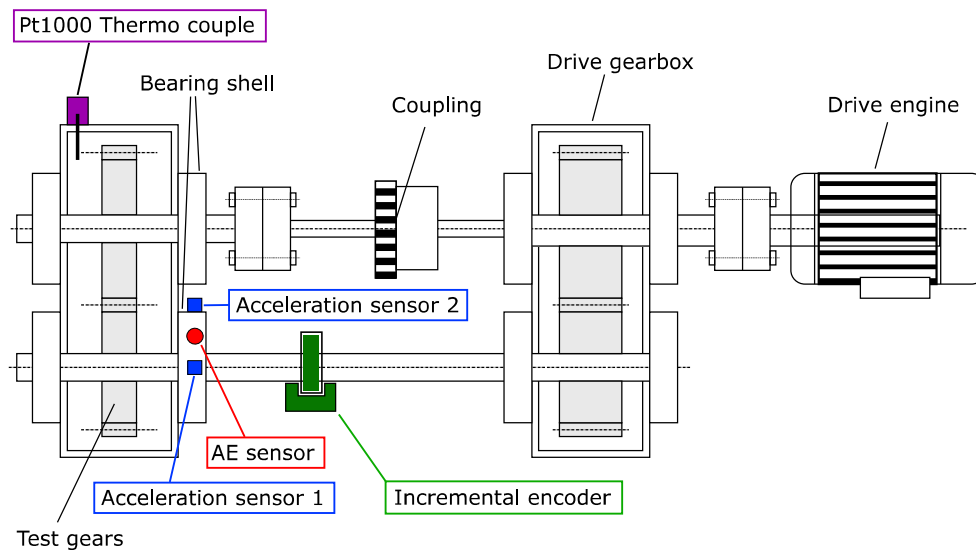

Figure 2: Sensor instrumentation for the B2B gear test rig

The AE sensor is able to measure high-frequency AE pulses above 50 kHz that are generated by the excitation of elastic waves when a pitted tooth flank is in tooth engagement. In addition, the oil temperature was measured with a Pt1000 thermocouple and the instantaneous shaft rotation angle of the torsional shaft with an incremental magnetic encoder.

After the measurement data acquisition, quantifiable indicators for pitting detection are obtained from the data. First, the vibration data is merged with the incremental encoder data and resampled. In the next step, sensor-dependent features are extracted from the acquired sensor signals. The features are extracted from the four central moments and the root mean square (RMS) values of the time domain signal and from the spectral power density of the vibration sidebands between the harmonics of the gear mesh order. In addition, significant features are extracted from the coefficients of Continuous Wavelet Transform (CWT) and are described in more detail in [1]. To evaluate the relationship between the pitting progress and the feature values, the Fisher discriminant criterion [21] was used. With this criterion value, the features with the highest sensitivity to pitting damage can be found.

The kurtosis feature of the CWT coefficients generated by the AE sensor and the calculated spectral power densities of the vibration sidebands between the 7th and 8th harmonic of the gear mesh order generated by the acceleration sensors provided the most robust features for all gear variants tested. Figure 3 shows the normalized feature values with the highest sensitivity to pitting damage of a test gear variant with a comparatively high single pitch deviation.

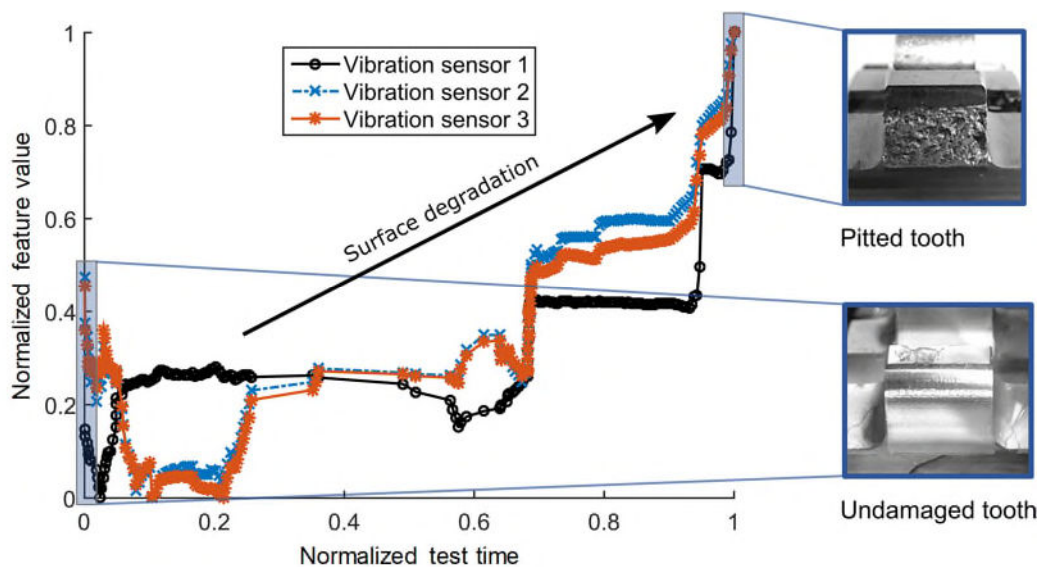

Figure 3: Pitting detection features

The complete test results for the other test gear variants can be found in [1].

The pitting tests revealed that the features calculated from acceleration sensor data should be obtained from the sideband spectrum and the features calculated from AE sensor data should be obtained from the CWT coefficients. Although the results did not show that AE sensors

allow earlier pitting detection than acceleration sensors, the AE technology has the advantage that the high-frequency range of the AE sensor improves the separability between pitting-induced acoustic events in the high-frequency range and test bench vibrations in the low-frequency range. However, due to the higher sampling rate required and the associated higher hardware costs, first of all it must be examined whether the benefit justifies the higher effort.

3. Journal Bearing Monitoring

For hydrodynamic journal bearings, wear is the most essential damaging mechanism as a result of mixed or solid friction. These friction states are caused by conditions like low speeds, overload, start/stop cycles, insufficient oil supply or oil contamination. A breakdown of this component could have a negative impact on the product reliability which causes high maintenance costs and downtime. Therefore, the journal bearing should be monitored sufficiently.

The literature provides several possibilities to detect damaging friction states of journal bearings such as monitoring the bearing temperature, friction torque, electrical transfer resistance between shaft and bearing, oil and vibration analysis [17-19]. All these possibilities are either not feasible for the PGB application or reach their limits for early fault detection. A suitable opportunity to detect mixed or solid friction at an early stage is the use of acoustic emission (AE) technology. The acoustic emission (AE) technology provides a sensitive and robust method to detect friction conditions. In this work investigations were done for the classification of the three basic friction conditions fluid, mixed, and solid friction based on AE signals and pattern recognition techniques to provide a condition-based maintenance for hydrodynamic journal bearings. The suitability of these methods for monitoring the degradation state of hydrodynamic journal bearings is also shown. For this purpose, tests on subscale test rigs were done.

To differentiate between the three basic friction states several speed ramps have been run from high speeds to low speeds at a constant radial load. Figure 4 shows the raw AE signals (top) where the left figure illustrates the fluid friction state and the right figure the mixed friction state. Some modulation effects can be seen within one cycle for the mixed friction state. These modulation effects are indications for mechanical friction.

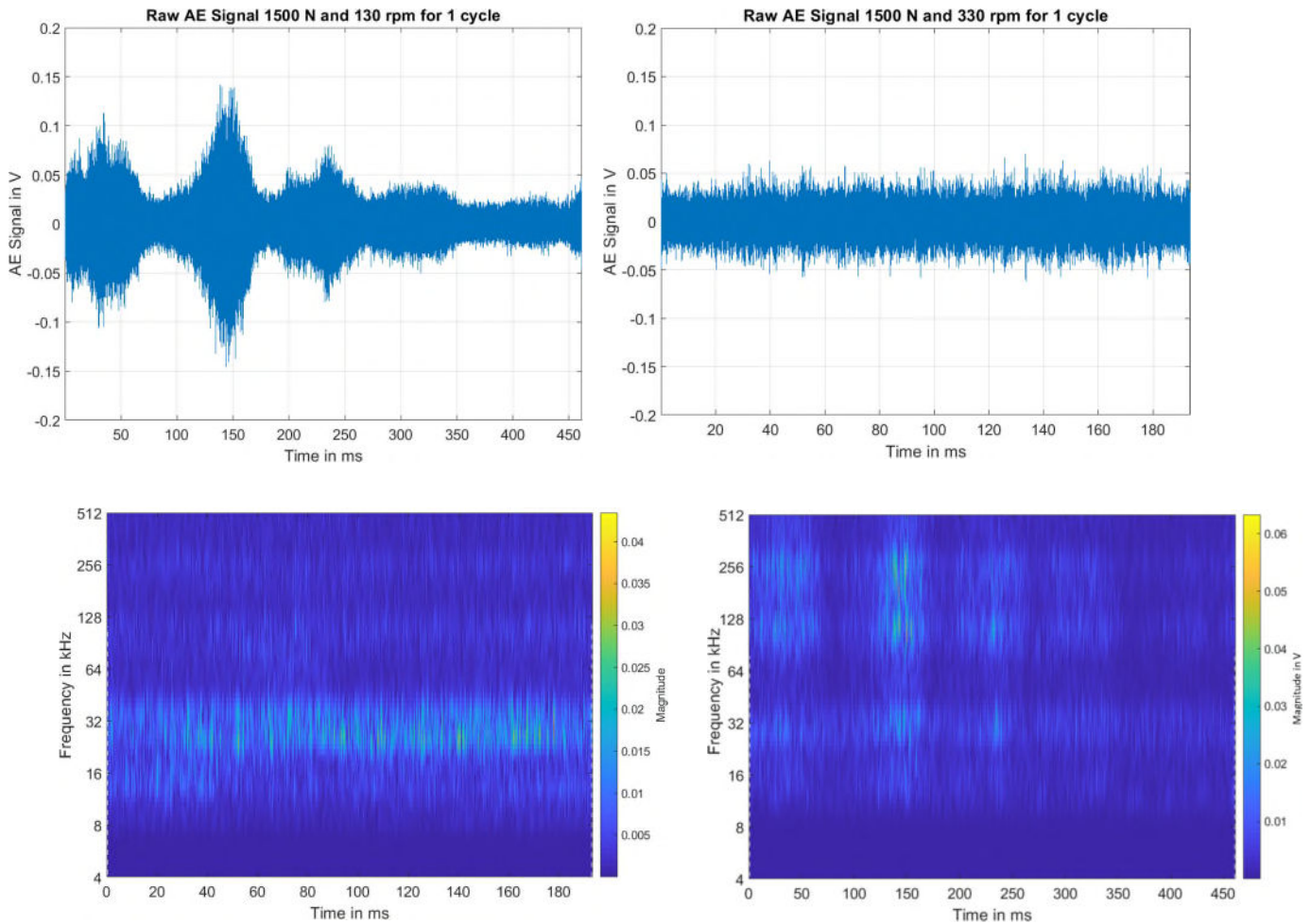

Figure 4: Comparison of raw AE signal and CWT of AE signal from fluid friction state (left) with raw AE signal and CWT of AE signal from mixed friction state (right).

In [10] it is shown that these effects could be used to localize friction within the journal bearing. The continuous wavelet transformation (CWT) was used to analyse the acquired AE signals (bottom figures). During mixed friction conditions, besides the low frequencies, which occur in fluid friction, also frequencies above 100 kHz occur. It can be concluded that in frequency bands lower than 100 kHz the differentiation between fluid, mixed, and solid friction is not possible with the AE technology [3].

Due to this result only frequency bands over 100 kHz should be considered. Therefore, methods for extracting distinct frequency bands (e.g. CWT, STFT etc.) should be used as pre-processing steps before extracting features for the classifier. Several features were extracted from the pre-processed patterns. The most promising features are the RMS and the Kurtosis for differentiating between the friction states (see Figure 5). These results and methods were verified at other subscale test rigs. The extracted features can now be used as the input for classifiers. The Support Vector Machine classifier offered good results for the classification of

the friction states.

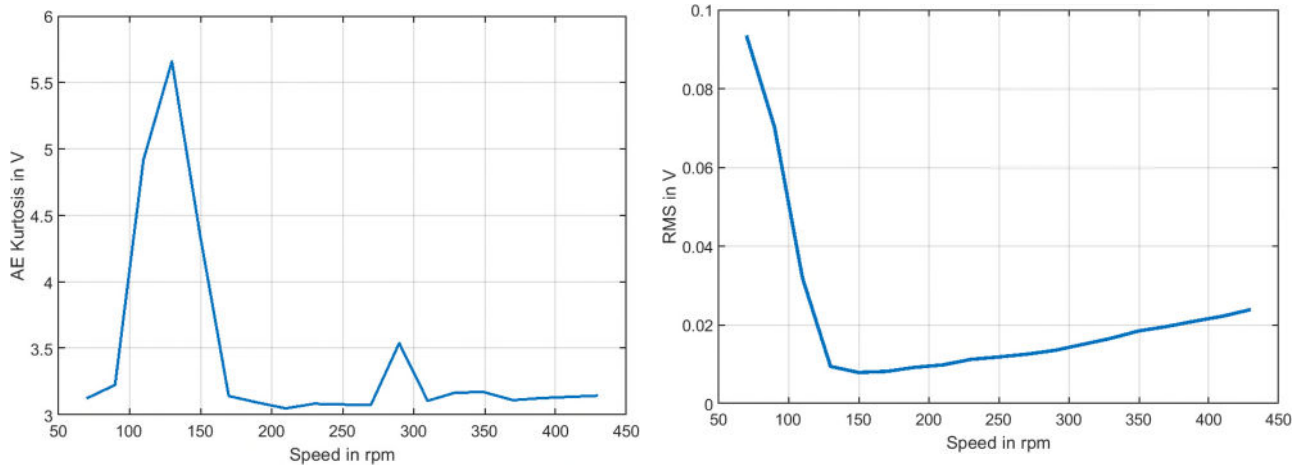

Figure 5: RMS and Kurtosis of pre-processed AE patterns for a speed ramp at a constant load.

To monitor a journal bearing it is not enough to only identify the actual friction state. The actual degradation state of journal bearings should be analysed as well. The degradation of journal bearings is typically characterized by the actual wear depth. Short time wear experiments were done at the TU Berlin test rig. During these tests the journal bearing was driven for an overall time of 18 hours at constant operating conditions to generate wear.

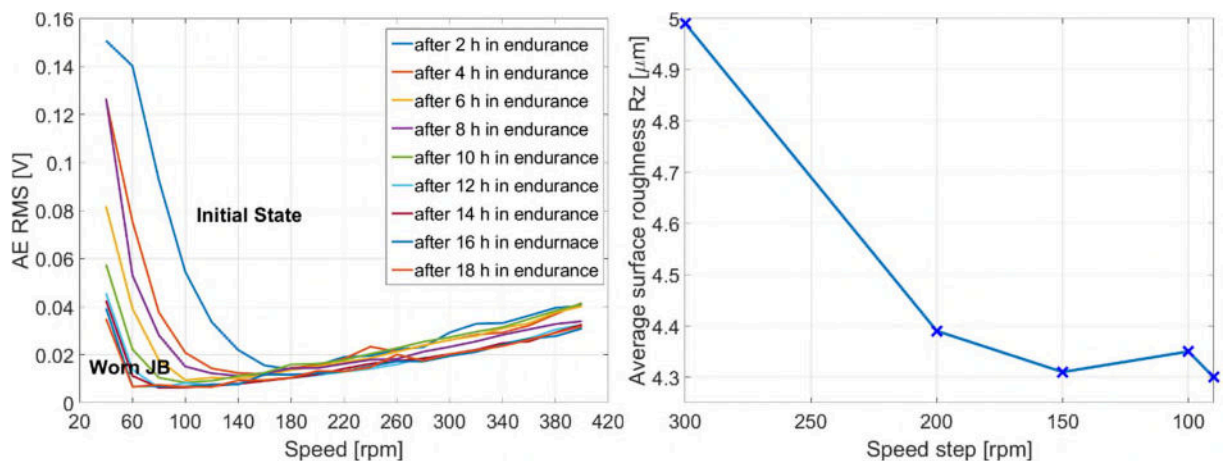

Figure 6: Degradation levels indicated by AE RMS for speed sweeps from 40 to 400 rpm, constant load of 1500 N (left). Average surface roughness over different speed steps (right).

After every step of 2 hours identical speed ramps were driven and the pattern recognition methods were applied. Figure 6 shows that the feature changes over the degradation state. This result shows that it is possible to monitor the degradation state, which is the actual wear depth, by using the AE technology in combination with suitable pattern recognition techniques [2].

In order to be able to predict the remaining useful lifetime (RUL) of journal bearings long-term wear tests must be done. These experiments are part of current research work. For this purpose, the TU Berlin test rig has been modified so that long-term experiment conditions can be set.

One specific challenge when using the AE technology for the PGB application is the position of the AE sensor. The nearest static part of the PGB is the ring gear on which the sensor can be mounted. However this position is not acceptable because the gear mesh contact between ring gear and planet gears acts as a low-pass filter so that high frequency friction signals are filtered out. In order to successfully apply the developed monitoring methods on the PGB the AE sensor must be mounted as close as possible to the mixed friction area. This area is rotating which makes a wireless data transfer necessary.

4. Wireless Data Transfer Unit

As depicted on the left hand side in Figure 7, the generic arrangement of a planetary style gearbox with the bearing between planet and carrier.

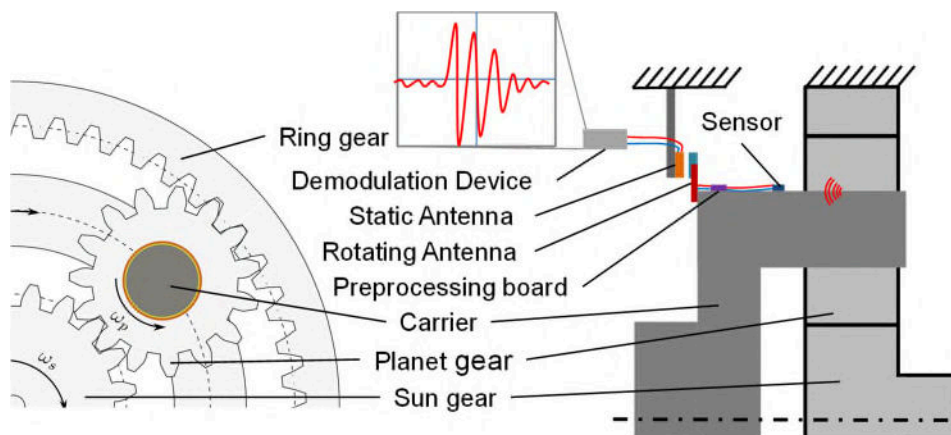

Figure 7: Schematic of Planetary gearbox and applied Wireless Data Transfer Unit (WDTU)

As stated in Section 3 an acoustic emission sensor must be able to measure up to 1 MHz bandwidth (Reference) in a position close to the journal bearing. Hence a signal transfer from the rotating carrier to the static part of the gearbox is required. Beginning with common environmental requirements of a gearbox the data transfer must deal with an oily environment, temperatures above 120°C, and strong vibrations caused by the gear train. A system engineering based assessment was carried out, to understand the requirements of a WDTU solution. As a result a sensor node containing comprehensive electronics e.g. as presented in [16] can't be applied. Currently available high temperature electronics either do not meet the

functional requirements or the expected reliability levels. However in further investigations a WDTU could be identified, which had already been tested on a PUMA helicopter main gearboxes [22], [6] or [15]. The WDTU from Cranfield University [UK] meets the requirements of the measurement chain for the gearbox environmental conditions.

The WDTU works on a similar principle to homodyne radar and in some respects to a near-field RFID (Radio frequency identity device) [23]. The system is depicted in Figure 8. The transceiver (A) generates the carrier signal and transmits it through a coaxial cable (1) to the matching network (B) which is used to tune the characteristic impedance of the static antenna with which it is connected by a pair of wires (3). The static coil transmits this carrier wave to the rotating antenna where it is picked up by a twisted pair of wires (4) and rectified and smoothed within the processing unit (C). This creates a DC voltage which is used to power an amplifier and filter stage which is connected by a cable (5) to the sensor (D). This is where it differs from RFID as this sensor signal, after it has been filtered and amplified, is used to tune the resonant frequency of the rotating antenna using a varactor diode. This allows a continuous signal to be transmitted which is representative of the desired signal from the sensor.

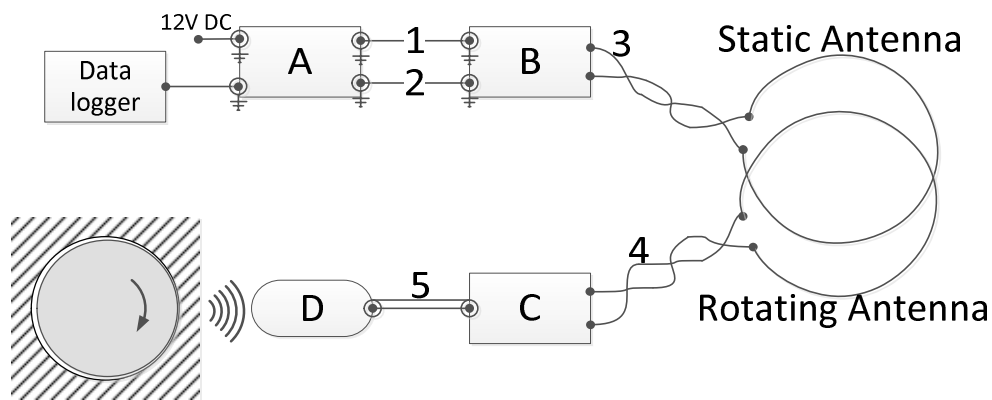

Figure 8: WDTU system overview.

The static antenna detects this resonant frequency modulation as backscatter of the transmitted signal and this is then sent back to the transceiver (A) via a coaxial cable (2) where it can be recovered by comparison to the carrier wave signal used to drive the static antenna.

The design of the system presented some challenges due to the mass and size constraints combined with the environment within which the device needs to operate. Additional complexity was created by the need to include good RF shielding and grounding when sensor elements can create a ground loop through the device under test.

The combination of journal bearing mixed friction detection and WDTU enables a detailed monitoring of a JB inside a planetary gearbox. A mockup test was executed to represent the integration of the antennas in the subscale planetary gearbox to demonstrate the ability of the WDTU to cope with the speeds and perform the signal transfer. The dominant gear mesh signal is represented by a triangular wave signal and an estimated 1000 times smaller sinusoidal signal at 277.85 kHz represents occurring mixed friction of the journal bearing.

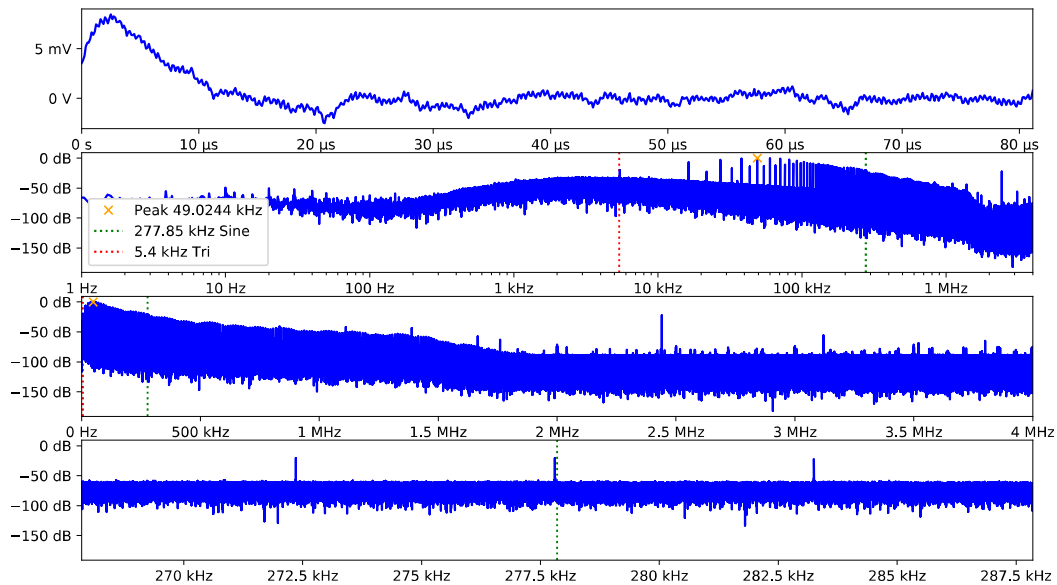

Figure 9: Test Result Subscale WDTU at 2200 min-1

The test demonstrates that the mixed friction signal can be transferred and extracted as shown in Figure 9. The red dotted lines highlight at 5 kHz the gear mesh from the signal generator. The signal from the simulated mixed friction can also be seen highlighted by the dotted green line at 277.85 kHz. What remains, is the ratio of the dominant gearbox gear mesh and the subsequent harmonics compared to the mixed friction pattern.

5. Conclusion and Outlook

In this work new monitoring concept studies are presented for a power gearbox integrated into a TurboFan power plant (UltraFan®).

Different methods were assessed to monitor gear vibration and the associated benefits and drawbacks have been identified. For dynamic engines such as a jet engines rotor synchronous resampling is recommended due to rotational speed fluctuations and the resulting smeared frequency spectrum. This helps to significantly minimize the signal noise and to detect an

anomaly in the order spectrum earlier than without resampling.

Acoustic emission sensors provide a sensitive method to monitor the journal bearing for different purposes such as mixed friction detection, coating degradation, and coating defects. In a planetary gearbox a wireless data transfer unit is required to measure close to the bearing friction area up to 1 MHz bandwidth.

A proven technical data transfer solution could be identified, which had been demonstrated on helicopter applications with roller bearings. The WDTU is modified to accommodate the requirements of the power gearbox and the purpose to measure mixed friction conditions in journal bearings.

Further tests are planned on a sub scale planetary gearbox [8] to verify, that the presented methods are capable to achieve monitoring capability for gears and journal bearings.

6. Acknowledgment

Thanks to Julian Worskett of JWD Ltd. for his invaluable radio communications expertise.

Thanks to the team from the FZG named Dr. Michael Otto and Uwe Weinberger for the support to integrate the WDTU into the sub scaled gearbox and the test opportunity.

Thanks to the team of WZL named Dr. Christoph Löpenhaus and Philipp Scholzen for the support during the pitting test campaigns.

Many thanks to the participated colleagues and researches involved in this monitoring study work for a planetary gearbox.

We also acknowledge financial support through funding from the BMWi within the Luftfahrtforschungsprogramm LuFo.

7. References in this document

- [1] M. Grzeszkowski, P.Scholzen, S. Nowoisky, C. Gühmann, C. Löpenhaus, G. Kappmeier, "Experimental study on the pitting detection capabilities for spur gears using acoustic emission and vibration methods," in AGMA Fall Technical Meeting, Chicago, 2018.
- [2] N. Mokhtari, C. Gühman and S. Nowoisky, "Approach for the degradation of hydrodynamic journal bearings based on acoustic emission feature change," in

Prognostic and Health Management, Seattle, 2018.

- [3] N. Mokhtari, F. Rahbar and C. Gühmann, "Differentiation of journal bearing friction states and friction intensities based on feature extraction methods applied on acoustic emission signals," *Technisches Messen*, vol. 84, no. S1, p. 6, 2017.
- [4] G. Norris, "Aviationweek," 06 02 2018. [Online]. Available: <http://aviationweek.com/commercial-aviation/rolls-unveils-intelligentengine-digital-strategy>. [Accessed 08 10 2018].
- [5] N. Mokhtari, M. Grzeszkowski and C. Gühmann, "Vibration signal analysis for the lifetime-prediction and failure detection of future turbofans components," in *Schwingungen in rotierenden Maschinen (SIRM)*, Graz, 2017.
- [6] D. Fang, M. Greaves and D. Mba, "Helicopter main gearbox bearing defect identification with acoustic emission techniques," in *IEEE Prognostics and Health Management*, Ottawa, 2016.
- [7] M. Greaves, "Towards the next generation of HUMS sensor," in *ISASI*, Adelaide, 2014.
- [8] TUM, "Ein Getriebe für 100.000 PS," 26 04 2018. [Online]. Available: <https://www.youtube.com/watch?v=Zhyz3A6deZ4>. [Accessed 11 10 2018].
- [9] M. Grzeszkowski, C. Ende and S. Nowoisky, "Verfahren und Vorrichtung zur Überwachung der Kinematik eines epizyklischen Planetengetriebes". Deutschland Patent DE102017121239.6, 2017.
- [10] N. Mokhtari, S. Nowoisky "Verfahren und Vorrichtung zur Überwachung eines Gleitlagers" Deutschland Patent DE 10 2017 119 543, 2019
- [11] G. Norris, "Aviationweek," 05 09 2017. [Online]. Available: <https://aviationweek.com/commercial-aviation/rolls-gearbox-hits-record-power-level>. [Accessed 05 04 2019].
- [12] G. Norris, "Aviationweek," 27 05 2015. [Online]. Available: <https://aviationweek.com/technology/rolls-freezes-design-first-ultrafan-test-gear>. [Accessed 05 04 2019].
- [13] U. Ebner, " Flugrevue," 12.10.2017, [online], Available: <https://www.flugrevue.de/flugzeugbau/prototyp-im-test-rolls-royce-ultrafan-getriebe->

gigant/. [Accessed 05 04 2019].

- [14] J. Bennet, " Popularmechanics," 28.10.2016, [online], Available: <https://www.popularmechanics.com/flight/a23603/rolls-royce-tests-powerful-turbofan-gearbox/>. [Accessed 05 04 2019].
- [15] D. Mba, M. Greaves, L.Tauszig and E. Faris, Novel Internal Sensors for Helicopter Main Rotor Gearboxes, 40th European Rotorcraft Forum, At Southampton, UK, September 2014
- [16] J. Funck, R. Knoblich, D. Scholz, S. Nowoisky and C. Gühmann, Drahtloses Messsystem für Temperaturen in Kraftfahrzeugkupplungen, TM – Technisches Messen, 2013
- [17] J. Deckers, Entwicklung einer Low-Cost Körperschallsensorik zur Überwachung des Verschleißverhaltens von wälz- oder gleitgelagerten Kreiselpumpen kleiner Leistung, PhD thesis, Gerhard-Mercator-Universität Duisburg, 2001.
- [18] P. Raharjo, An Investigation of Surface Vibration, Airborne Sound and Acoustic Emission Characteristics of a Journal Bearing for Early Fault Detection and Diagnosis, PhD thesis, University of Huddersfield, May 2013.
- [19] M. Fritz and A. Burger and A. Albers, Schadensfrüherkennung an geschmierten Gleitkontakten mittels Schallemissionsanalyse, Institut für Maschinenkonstruktionslehre und Kraftfahrzeugbau, Universität Karlsruhe, 2001.
- [20] DIN ISO 14635 Teil 1; Mai 2006. Zahnräder. FZG-Prüfverfahren. FZG-Prüfverfahren A/8,3/90 zur Bestimmung der relativen Fresstragfähigkeit von Schmierölen.
- [21] Bishop, Christopher M. (2009): Pattern recognition and machine learning. Corr. at 8. print. New York, NY: Springer (Information science and statistics).
- [22] M. Greaves, F. Elasha and et al. EASA Final Report: Vibration Health or Alternative Monitoring Technologies for Helicopters, 04.06.2015, [EASA REP RESEA 2012_6](#)
- [23] R. Want, An Introduction to RFID Technology, Pervasive Computing, January-March 2006, pp 25-33, DOI: 10.1109/MPRV.2006.2
- [24] Vecer, P.; Kreidl, M.; Smid, R. (2005): Condition Indicators for Gearbox Condition Monitoring Systems. In: Acta Polytechnica Vol. 45 No. 6/2005, p. 1–6.