

Technical Disclosure Commons

Defensive Publications Series

April 2020

Non-Contact Characterization of Container Surfaces

Jay M. Shores

Courtney Timms

Matheus Guedes

Carlos Nobrega

Babak Raeisinia

Follow this and additional works at: https://www.tdcommons.org/dpubs_series

Recommended Citation

Shores, Jay M.; Timms, Courtney; Guedes, Matheus; Nobrega, Carlos; and Raeisinia, Babak, "Non-Contact Characterization of Container Surfaces", Technical Disclosure Commons, (April 14, 2020)

https://www.tdcommons.org/dpubs_series/3140



This work is licensed under a [Creative Commons Attribution 4.0 License](https://creativecommons.org/licenses/by/4.0/).

This Article is brought to you for free and open access by Technical Disclosure Commons. It has been accepted for inclusion in Defensive Publications Series by an authorized administrator of Technical Disclosure Commons.

Non-Contact Characterization of Container Surfaces

Disclosed are systems for non-contact characterization employing laser optical scanning techniques for evaluating surface characteristics of metal products, such as aluminum containers. Laser light is scanned over a surface and distances to the surface are measured and converted to a surface profile, used to identify characteristics in the surface, such as forming defects.

Background

Wrought metal may be formed into many products; during the forming process, however, forming defects may occur, arising from the forming process itself or due to the metallurgical, materials, textural, microstructural, or crystal properties of the metal. For example, aluminum may be formed into containers by way of one or more drawing, ironing, necking, or other forming processes. Ears may be formed at various stages of drawing, due to the anisotropy of the metal, for example. As another example, score lines may be imparted on a container surface during drawing or ironing, reducing surface quality of the resultant metal product. Characterizing these and other forming defects is useful for improving aluminum product manufacturing.

Methods and Results

Methods, techniques, systems, and computer program products for characterizing metal product surfaces using non-contact optical characterization are described. Surface profiles may be obtained and analyzed to identify surface characteristics and the presence of defects. The non-contact characterization techniques described herein achieve a number of advancements over conventional surface characterization techniques, such as contact-based characterization techniques, and overcome a variety of problems associated with these conventional techniques.

Laser optical scanner 125 is shown in FIG. 1 as supported on translatable stage 130, shown as a vertical translation stage, in order to adjust a vertical position of laser optical scanner 125 relative to metal product 105. In this way, laser optical scanner 125 may be used to characterize metal products 105 of different heights and/or to characterize different portions of a surface of metal product 105. Laser optical scanner 125 is illustrated aligned to a top region of metal product 105, such as to investigate a thread region or sealing region of metal product 105 but may additionally be aligned to an end region of metal product 105, such as to investigate earing characteristics or aligned to a shoulder region of metal product 105, such as to investigate a curved surface forming character, or at a plurality of heights to scan metal product 105.

Laser optical scanner 125 operates to expose the surface of metal product 105 to laser light 135. Scattered laser light 140 from the surface of metal product 105 is detected by an optical detector of laser optical scanner 125. In order to characterize a cylindrical surface of metal product 105, rotating table 110 may be rotated while laser optical scanner is exposing metal product 105 to laser light 135. Rotating table 110 may include a mounting fixture 120 to secure metal product 105 in place. Mounting figure may allow for accommodation of metal products 105 of different sizes and/or shapes. Detected scattered laser light 140 may allow determination of a distance between laser optical scanner 125 and the surface of metal product 105. This distance information is transformed to provide a surface profile, such as a surface depth profile, of the surface of metal product 105. The surface profile may be analyzed to identify surface characteristics of the metal product 105. For example, a deviation of the surface of metal product 105 from being perfectly cylindrical (i.e., eccentricity) may be determined. As other examples, earing heights and/or trimming defects may be determined for metal product 105. The presence of forming defects, such as score lines, misshaped threads, surface pleats, looper lines, surface wrinkles, etc. may also be determined for metal product 105 using the surface profile.

A variety of laser optical scanners are useful with the systems and methods described herein. For example, a laser optical scanner may include a one-dimensional (1D) laser scanner that may, for example, provide only a single measured position or distance as an output. In some cases, one-dimensional data generated by a 1D laser scanner may be converted into two- or three-dimensional data by controlling and tracking positions and/or angles between or of the 1D laser scanner and an object being scanned. In another example, a laser optical scanner may include a two-dimensional (2D) laser scanner that may, for example, provide a measured distance as a function of an angle or a position. Again, in some cases, two-dimensional data generated by a 2D laser scanner may be converted into three-dimensional data by controlling and tracking positions and/or angles between or of the 2D laser scanner and an object being scanned. In another example, a laser optical scanner may include a three-dimensional (3D) laser scanner that may, for example, provide a measured distance as a function of various angles and positions in the form of three dimensional data. Three-dimensional data from a laser optical scanner may be used to generate a 3D model of an object under investigation for characterization.

FIG. 2 provides a plot showing example surface characterization data, which may be referred to as a radial surface scan. The data shown in FIG. 2 include a radius of a product as a function of angle around the metal product. Although only a single radial scan is shown in FIG. 2, some laser optical scanners useful with the presently disclosed systems and techniques may allow for multiple vertically offset radial scans to be obtained simultaneously in a single 360° rotation of the metal object, depending on the configuration. Surface wrinkles are identified in the metal product characterized in FIG. 2, where shallow repetitive variations along a portion of a surface are observed. The radii in FIG. 2 may be derived by obtaining a surface profile using an optical characterization device as the metal product is rotated, such as by using a system shown in FIG. 1.

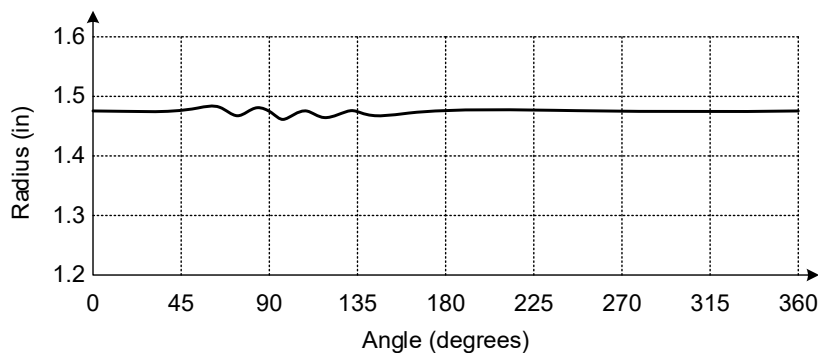

FIG. 2

FIG. 3 provides an overview of an example method for characterizing a metal product. Optionally, the rotating table may be substituted by a translating table (e.g., a 1D or 2D translation stage). The rotating table may correspond to an automated and/or computer controlled turntable, allowing precise control over the rotation angle, such as at a sub-degree level, e.g., at increments of between 0.1° and 0.5°, or over any particular angle. The rotating table may receive commands identifying a position or angle and may then rotate the table accordingly in response to the commands. The commands may be generated or issued by a processor, for example, such as in response to user input identifying a process to start scanning the metal product supported by the rotating table.

Conclusion

The laser optical scanning techniques employed are used to evaluate surface characteristics of aluminum containers or metal tooling, for example, among other uses.

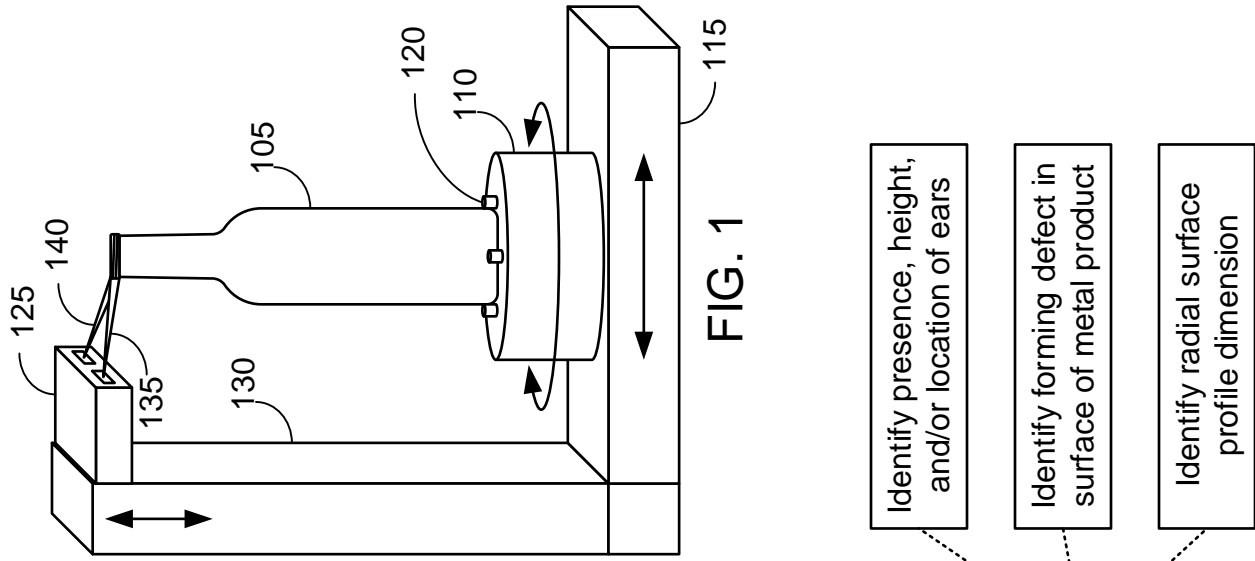

FIG. 1

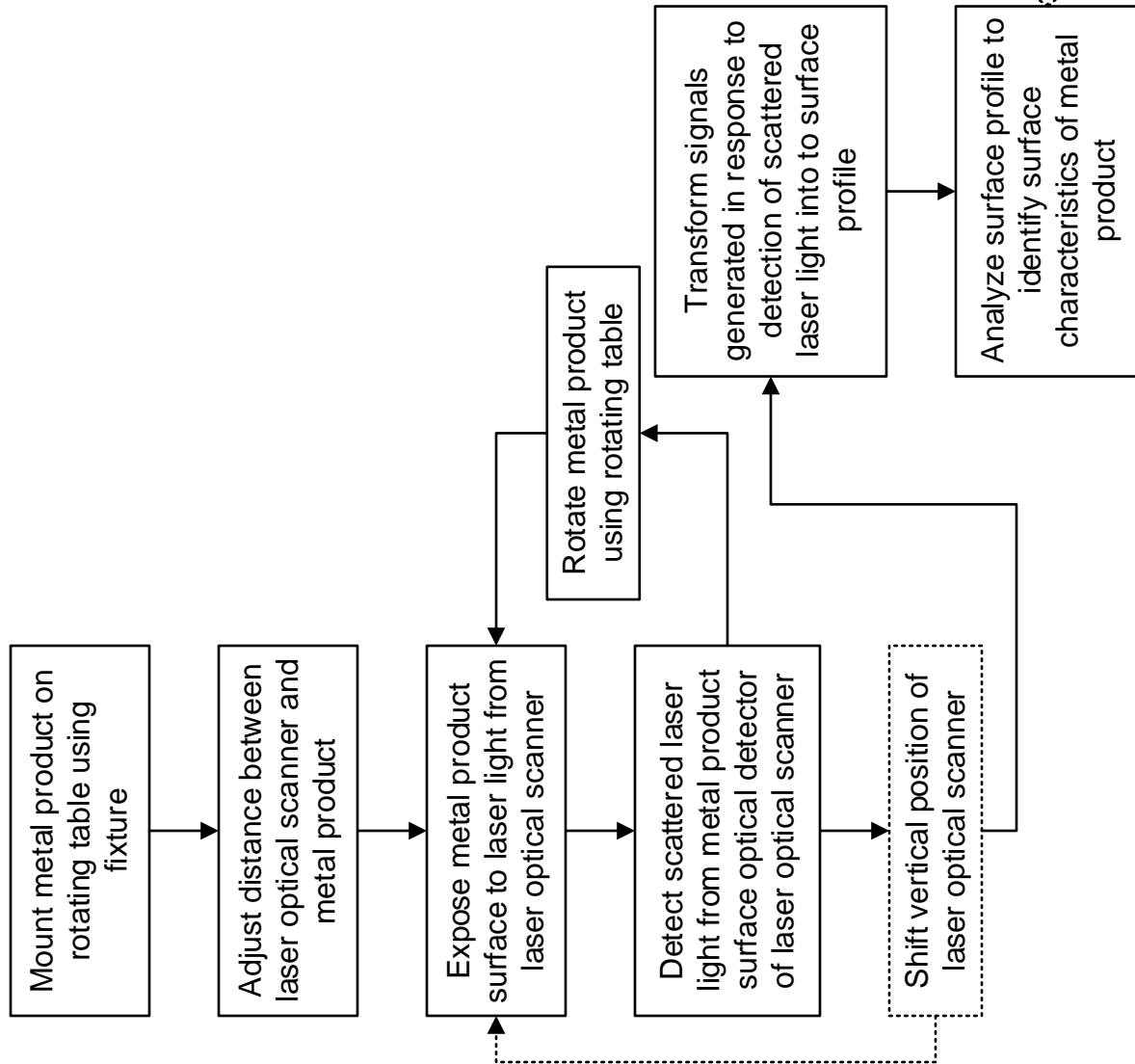

FIG. 3