

**A CONCEPTUAL FRAMEWORK OF ADAPTIVE  
ARCHITECTURE: A CYBERNETICS APPROACH TO BIO-  
INSPIRED STRATEGIES**

A Dissertation  
Presented to  
The Academic Faculty

by

Shilpa Mehta

In Partial Fulfillment  
of the Requirements for the Degree  
MASTER OF SCIENCE IN ARCHITECTURE in the  
SCHOOL OF ARCHITECTURE

Georgia Institute of Technology  
[AUGUST 2019]

COPYRIGHT © 2019 BY SHILPA MEHTA

**A CONCEPTUAL FRAMEWORK OF ADAPTIVE  
ARCHITECTURE: A CYBERNETICS APPROACH TO BIO-  
INSPIRED STRATEGIES**

Approved by:

Dr. Russell Gentry, Advisor  
School of Architecture  
*Georgia Institute of Technology*

Dr. Dennis Shelden  
School of Architecture  
*Georgia Institute of Technology*

Prof. Lars Spuybroek  
School of Architecture  
*Georgia Institute of Technology*

Date Approved: [May 17<sup>th</sup>, 2019]

To my brother

For his advice, his patience and his faith.

Because he always understood

## **ACKNOWLEDGEMENTS**

Foremost, I would extend my gratitude towards my advisor, Dr. Russell Gentry, for his continuous support and encouragement for not only this thesis but also throughout my time in Georgia Tech. I would like to express my deepest appreciation to my committee members, Dr. Dennis Shelden and Prof. Lars Spuybroek, for their guidance and insightful comments. I would also like to thank my loving husband, my strength, Pallav Kuiya, who had the patience to deal with distance right after our wedding in December 2018, as I immediately came after to finish my degree in Atlanta while he lived in New Jersey.

I am grateful to my siblings Rohit and Shipra and my parents for their constant motivation and moral support throughout my life. I must express my profound gratitude to my entire family for providing unfailing support and always steering me in the right direction.

Finally, last but by no means the least, I would like to thank Georgia Institute of Technology and School of Architecture for believing in me and introducing me to this incredible world of architecture and technology I never thought I can be a part.

## TABLE OF CONTENTS

<b>ACKNOWLEDGEMENTS</b>	<b>iv</b>
<b>LIST OF FIGURES</b>	<b>vi</b>
<b>SUMMARY</b>	<b>viii</b>
<b>CHAPTER 1. Introduction</b>	<b>1</b>
1.1 A Changing Paradigm of the world	1
1.2 Energy	5
1.3 Human-Comfort	9
1.4 Adaptibility	10
<b>CHAPTER 2. Adaptiveness Framework</b>	<b>13</b>
2.1 Nature as Model	13
2.2 Nature as Feedback	20
2.3 Technology of Nature	20
<b>CHAPTER 3. Design &amp; Technology approach towards architecture of change</b>	<b>22</b>
3.1 Cybernetics: Catching up with Past to Present	22
3.2 Transformable, Flexible and Responsive Design	29
3.3 Materiality	35
3.4 Change and Growth	37
<b>CHAPTER 4. Case Studies</b>	<b>38</b>
4.1 Hygroscope+Hydroskin	38
4.2 Al Bahar Tower	44
4.3 BLOOM	49
4.4 BIQ House	52
<b>CONCLUSION</b>	<b>55</b>
<b>REFERENCES</b>	

## LIST OF FIGURES

Figure 1: Rabbit-duck Illusion by Ludwig Wittgenstein used by Kuhn to explain paradigm shift.....	2
Figure 2: Global land-ocean temperature index from the year 1880 to 2020. (GISS 2018)3	3
Figure 3: Global land-ocean temperature index from the year 2010 to 2018. (GISS 2018)4	4
Figure 4: Time series: Visualization images of Earth showing Global land-ocean temperature index from 1978 to 2018. (GISS , 2018).....	5
Figure 5: The Greenhouse Effect, adapted from: IPCC, Climate Change 2007. (Cambridge University Press 2007, 115). .....	7
Figure 6: The International Energy Efficiency Scorecard (2018).....	9
Figure 7: Thermal interaction of human body and environment (ASHARE, 2013)(p.8.2)11	11
Figure 8: Nature as a Model- (developed by author) .....	14
Figure 10: Silk Pavilion at MIT; Placement of silkworms to study their patterns.....	16
Figure 11: Silk Pavilion Dome at MIT Media Lab .....	17
Figure 12: Robotic arm fabricating ICD/ITKE Research Pavilion, Stuttgart, Germany, 2012 .....	18
Figure 13: ICD/ITKE Research Pavilion by Achim Menges and Jane Knippers, Stuttgart, Germany, 2012.....	18
Figure 14: Stratus Project by RVTR, Ann Arbor, Michigan, 2011 .....	20
Figure 15: Nature's Feedback Model- (developed by author).....	20
Figure 16: Design & technology approach to bio-inspired adaptable architecture (Lopez, Rubio, Martin, & Croxford, 2017)).....	22
Figure 17: Feedback loops of Cybernetics (Heylighen, Joslyn, & Turchin, 2000) .....	24
Figure 18: Positive and Negative Feedback (Heylighen, Joslyn, & Turchin, 2000) .....	25
Figure 19: Michael Fox's explanation of Homeostasis building.....	27
Figure 20: Various Phases of Mitosis .....	28
Figure 21: Second order of Cybernetics system .....	29
Figure 22: Section of RV house (0° Evening Rotation, 90° Kitchen Rotation and 180° Day Rotation).....	31
Figure 23: Greg Lynn's RV House Prototype .....	31
Figure 24: The Sharifi-ha House.....	32
Figure 25: Main concept showing the rotation of rooms in and out .....	33
Figure 26: Hoberman Sphere .....	34
Figure 27: Expanding Sphere, Korea Aerospace Research Institute .....	35
Figure 28: The Living Glass .....	36
Figure 29: Biological principle of hygroscopic material system of conifer cone reacting to moisture change .....	38
Figure 30: HygroSkin inspired by spruce cone .....	39
Figure 31: Close-up photo of HygroSkin in open state at low relative humidity .....	40
Figure 32: HygroSkin – Meteorosensitive Pavilion in Stadtgarten, Stuttgart.....	40
Figure 33: Exploded view of a module's buildup: initially planar plywood panel (left), elastically self-formed plywood panels with sandwich core (right) .....	41

Figure 34: Generation and simulation of the machine code for robotic sawing and trimming ..... 41

Figure 35: Opening and closing of the installation ..... 42

Figure 36: HygroScope: Meteorsensittive Morphology Installation display ..... 43

Figure 37: Al-Bahar Tower ..... 44

Figure 38: Dynamic mashrabiya-inspired from the past and from adaptive natural systems-  
folding and unfolding concept following the movement of the Sun (Karanouh, 2015). .. 45

Figure 39: Mashrabiya units at unfold, midfold and maximum-fold positions ..... 46

Figure 40: Details of Mashrabiya System ..... 47

Figure 41: Different layers of façade system ..... 47

Figure 42: Section drawing of shading screen and tower interiors ..... 48

Figure 43: Installation of Mashrabiya Screens ..... 49

Figure 44: Interior office spaces at Al Bahar Tower ..... 49

Figure 45: Bloom ..... 50

Figure 46: Panel details of Bloom ..... 51

Figure 47: Energy generation and use in BIQ House ..... 52

Figure 48: BIQ House ..... 53

Figure 49: Microalgae infused glazing panels: SolarLeaf ..... 53

## SUMMARY

This thesis develops the conceptual framework of adaptive architecture, where adaptability is defined by the capacity of an organism or a system to act in response to variations in natural conditions. This research considers how living beings catch, convert, store and process energy, water and daylight. It asks how does nature chill off, warm up, give shade, and control light. In contrast with living creatures, buildings are ordinarily considered as static, lifeless objects. However, a building's environment and its inward conditions are dynamic, and there exists the potential to use inspiration and examples from nature to cultivate greater adaptability of the façade for upgraded building performance. To implement this process of adaptability in architecture one needs to understand the change and a sense of intelligence that architecture must possess.

This research examines principles of cybernetics, to learn from it, and to establish a bridge between intelligence and architecture that can lead to adaptability. Cybernetics can help bridge organic and inorganic aspects of architecture and machines. This thesis will help develop a better understanding of climate adaptive architecture and other disciplines contribution to it. Essentially, architects need to develop an understanding of the framework that involves design computation, intelligent environment and role of nature coming together for achieving adaptive architecture while it addresses the issue of climate change.

Keywords- Bio-Inspired; Adaptive Architecture; Climate Change; Cybernetics



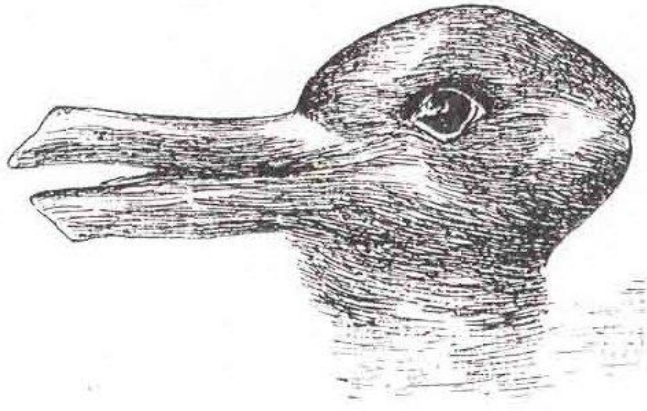
## CHAPTER 1: INTRODUCTION

This research is not about biomimicry or buildings that move. Rather, it is an attempt to research and provide a conceptual framework for architects from around the world who may not have a comprehensive understanding of computational design and architecture. To do so, this research takes the route to acknowledge a major issue of climate change. Climate change is real; as we can see the Earth's climate system change resulting in new weather patterns that can last for years to come. According to NASA, The Effects of Climate Change 2019, from increasing heat waves to intense storms to rise in sea levels, climate change is already affecting the world. Architects and designers have the responsibility to provide solutions for the coming time and future generations to deal with this unforeseeable change.

### *1.1 A Changing Paradigm of World*

Over the course of history, humanity and natural sciences have seen a paradigm shift. The concept a of paradigm shift was first brought by Thomas Samuel Kuhn who was an influential American physicist, historian and philosopher of science in the 20<sup>th</sup> century (Kuhn, 1962). In his controversial book, The Structure of Scientific Revolutions, he said that paradigm shift is a scientific revolution which occurs when scientists encounter anomalies that cannot be explained by a universally accepted framework. When enough anomalies are found in the current paradigm, the scientific discipline goes into the state of crisis. During this state, new ideas, maybe the ones which were disregarded earlier are tried again which eventually form a new paradigm. The new paradigm has its new followers,

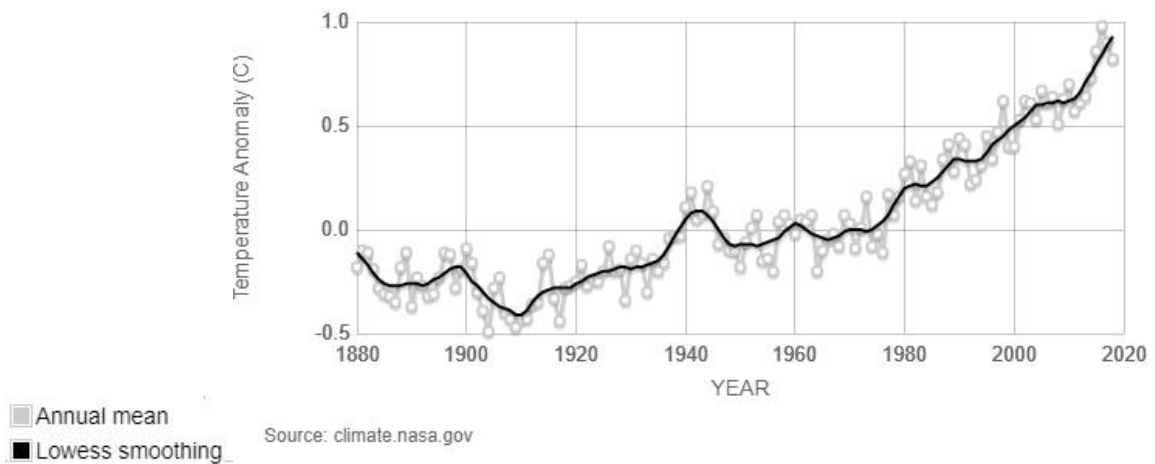
who have their own intellectual clash with the old paradigm. This paradigm shift can cause one to see the same information in a different way. The rabbit-duck illusion image, made famous by Ludwig Wittgenstein, is the one of the best examples to demonstrate the idea of paradigm shift and how it causes difference in perception of the same piece of information.



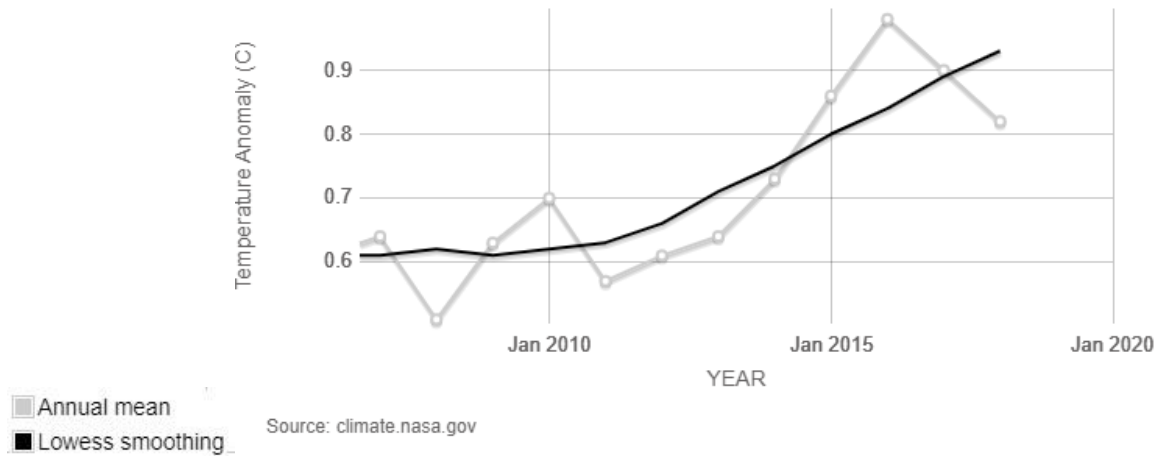
**Figure 1: Rabbit-duck Illusion by Ludwig Wittgenstein used by Kuhn to explain paradigm shift.**

This concept is useful not only to understand the changes in humanity over the years but also the important phenomenon of climate change. As we know that a paradigm does not shift until its followers are replaced by a new generation. This becomes intimidating when it comes to climate change. Climate change is an urgent issue that requires us to take actions soon, and we do not have a new generation of followers to wait for before the followers of the old paradigm decline. But what is the cause of climate change? It was the change of paradigm that we see throughout the history of humanity. The increased needs of humans to find stability and protection led them to exploit natural resources and systems for their benefit. The Industrial Revolution that started in the 18<sup>th</sup> century was the start of global climate change (Brownell & Swackhamer, 2015). Industrial Revolution had the intoxicating potential of mass production from fossil fuels with the help of human-built

machines. This led to a massive crushing of environment at a huge cost. With the Industrial Revolution mankind experienced the exponential growth and development of cities but it also saw a swift decline in our natural resources and wilderness that led us to global warming today. Therefore, when it comes to changing the way we look at climate change, we need to address the needs of our present without compromising our future and realize its importance sooner. We have enough data to understand the change in climate over the years to be fearful for our future. According to GISS (2018) reports released by NASA, there is a significant amount of change in global land-ocean index from the year 2010 to 2018 (Figure 3). This graph illustrates the change in global surface temperature relative average temperatures. The year 2016, was ranked the warmest on record. Figure 2 shows the change in global surface temperature from 1880-2020.

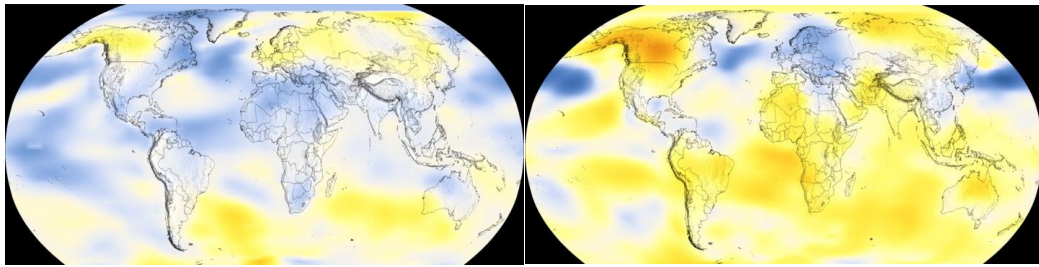


**Figure 2: Global land-ocean temperature index from the year 1880 to 2020. (GISS 2018)**



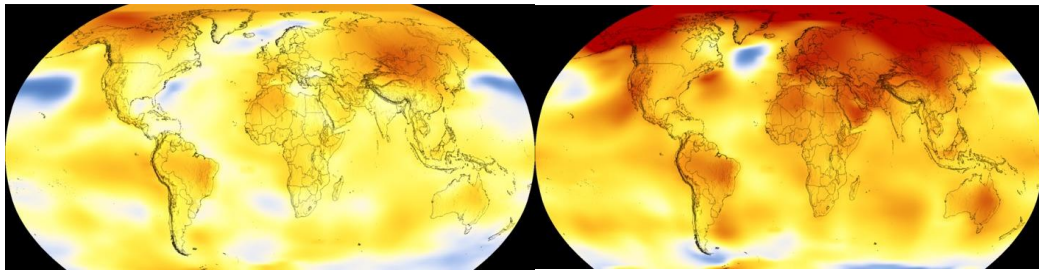
**Figure 3: Global land-ocean temperature index from the year 2010 to 2018. (GISS 2018)**

As stated by GISS (2018), eighteen of 19 warmest years all occurred since 2001. Figure 4 shows the time series visual images of Earth showing the change in surface temperatures from 1978 to 2018, where dark blue indicates areas cooler than average and dark red indicates warmer than average. As stated in Stanley (2007), “Global climate change is changing the places we know and cherish. Within our lifetimes, we will see the visible effects of global climate change on coastlines, coral reefs, glacier-carved mountains and other places, with potentially devastating ecological and economic consequences. While there is some uncertainty about the long-range predictions of the impacts of global climate change, there is no doubt that climate change is under way—and we know enough to take action now.” (pg. 1)



1978

1988



1998

2018

**Figure 4: Time series: Visualization images of Earth showing Global land-ocean temperature index from 1978 to 2018. (GISS , 2018).**

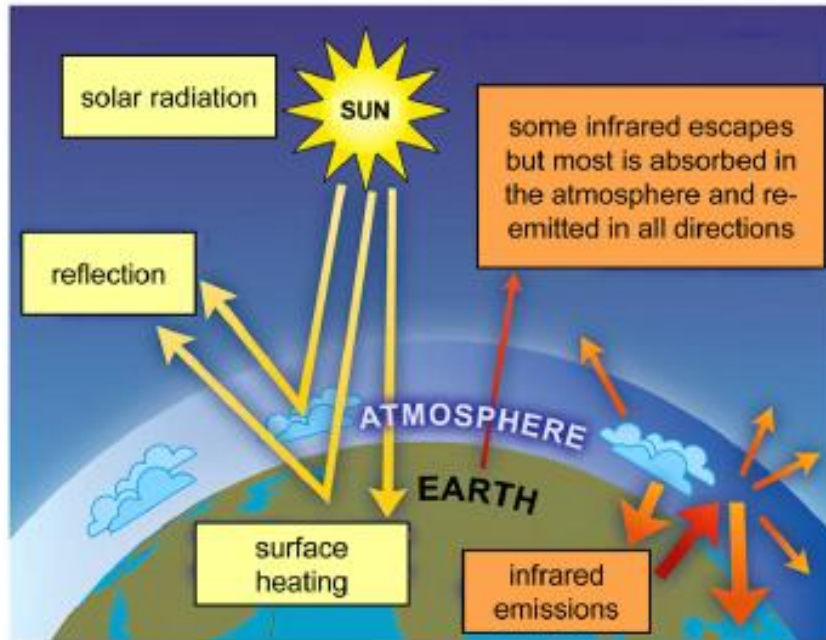
To bring this change, sustainable living is one of the most essential steps mankind has to take right now. Increase in awareness and change in behavior can accelerate the process towards a better tomorrow. The industrial revolution, technological advancement and our hostility towards natural resources might have led us to this situation of uncertainty, but realization of prospering in the disciplines such as sustainability, biomimetics and energy efficiency can help undo the unrestrained human malpractice.

### *1.2 Energy*

We cannot talk about sustainability without talking about energy and its influence on our society and habitats. Around 10,000 years ago, when humans were living in agrarian

communities, we were dependent on the environment to achieve a stable lifestyle. In that process of producing specific food and livelihood, humans may have altered natural composition of plants and animals. Many archaeologists popularized the term Fertile Crescent, a crescent-shaped region in Middle East as the starting point of farming. People started domesticating wild plants and animals for human use. Domesticated species were raised for food, clothing, shelter, medicines etc. By the time we reached the 18<sup>th</sup> and 19<sup>th</sup> century, the Western industrial revolution started using energy from fossil fuels like coal to accomplish production of efficient and powerful engines and later for generating electricity. Though we enjoyed development and innovations in the field of engineering, technology, medicine, but to the cost of our natural environment, by the end of the 20<sup>th</sup> century the energy crisis began showing a powerful impact of the global economy. By the 21<sup>st</sup> century, there was a sense of global awareness which began with the threat of increased natural “greenhouse effect” due to burning of fossil fuels and destruction of forests. As per Andersona, Hawkins and Jone (2016), the Earth’s surface is heated up when the solar radiations enter the atmosphere unhampered. As a result, energy is radiated as infrared rays, which are mostly absorbed by CO<sub>2</sub> and water vapors in the atmosphere and hence creates an insulating layer around the Earth. This process is called the greenhouse effect.

(Figure 5)

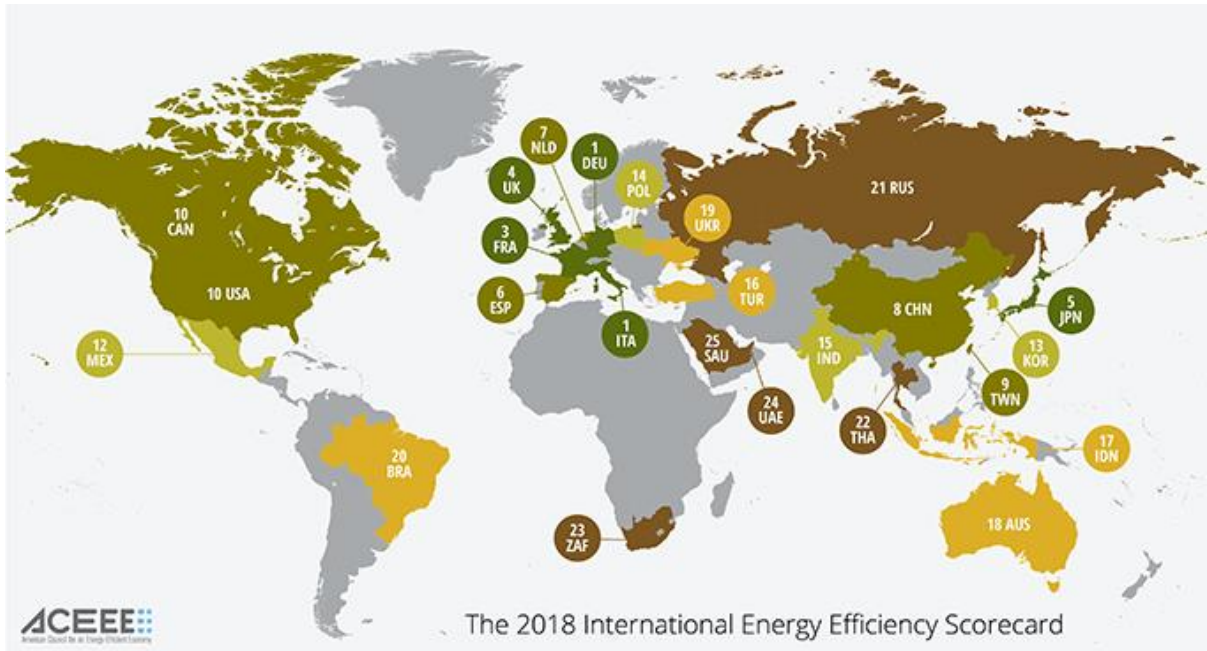


**Figure 5: The Greenhouse Effect, adapted from: IPCC, Climate Change 2007. (Cambridge University Press 2007, 115).**

For the past few years, increased burning of fossil fuels has raised the CO<sub>2</sub> levels in the atmosphere, which has intensified the natural greenhouse effect, thus making our earth warmer. Our warmer planet is now leading us to consume more energy in our buildings as there is a significant increase in our air conditioning loads (NASA, The Causes of Climate Change, 2019) (§ 8). Architects should analyze the need of energy flow required inside and outside of a building to have a sustainable building performance. What strategies were taken into consideration for energy efficiency before the time of industrial revolution and what needs to do be done for the coming future? Present generation of architects in the West, have started focusing on energy efficient architecture and improvement of building performances; but there are still countries in the East and other parts of the world who need to consider energy and climate as a chief concern in the design process. If we study the history of vernacular architecture in countries like India, Iran, Pakistan, Indonesia, and

Egypt, climate has always been a key factor in building designs, space programming, structures and use of building materials. This is due to less successful industrial revolution in these countries. For example, in India, industrial revolution came a little late in comparison to countries in West due to India's political and economic relationship with Britain. Although, India was a British colony, it dominated global cotton textile markets in the 18<sup>th</sup> century. But it took a hit when industrial revolution began in Great Britain. Using steam power in British mills reduced British cotton's cost by 85 percent, making its textile goods for the first time internationally competitive. Britain rapidly became the world's leading textile exporter, thereby displacing India. Great Britain instead began to export its own textiles to India. This led to the failure of Industrial Revolution in India at the point. As a result, it took decades for India to embrace modern industrial practices in its textile manufacturing, such as steam power and mechanized spinning and weaving (Ward, 1994). Due to this, in India passive design techniques were a second nature to the designers of vernacular architecture. But as we are advancing in technology and building sciences these countries are not focusing of the issue of climate and energy efficient buildings as much as they use to in the past. Not only that, although the use of passive techniques has reduced, there are no efforts taken as such to incorporate the active techniques and efficient systems in the project budget to enhance building performance. The American Council of Energy Efficient Economy (ACEEE) published an international energy efficiency scorecard (Figure 6), according to which (ACEEE, 2018), Germany, Italy and France are among the top three energy efficient countries in the world, analyzed on the basis of buildings performances, transportation, industry and overall national effort in using energy efficiently.



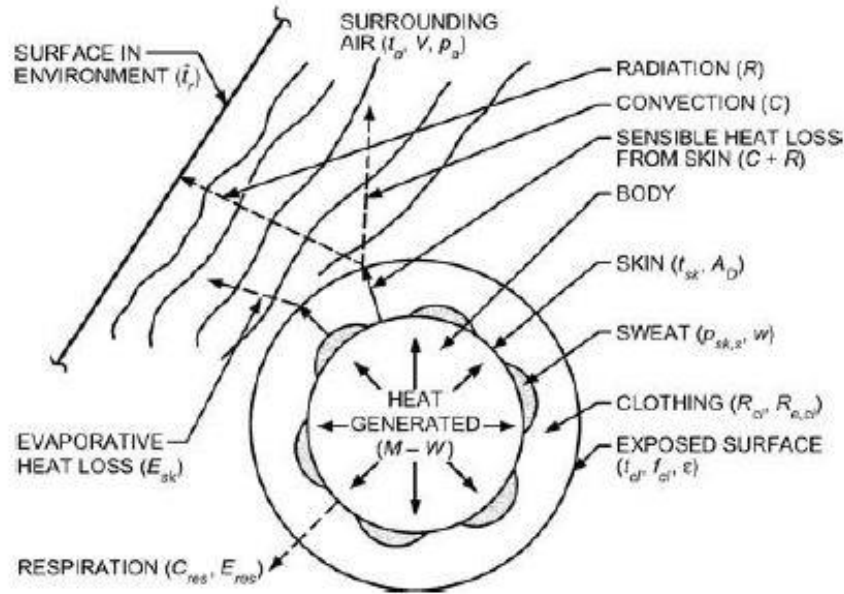


**Figure 6: The International Energy Efficiency Scorecard (2018)**

### *1.3 Human Comfort*

Human comfort is a state of mind that expresses ease and satisfaction with thermal environment. Humans eat food as the source of energy and release excess heat and moisture to the surrounding environment to regulate their internal temperatures. As heat transferred is proportional to temperature difference, bodies lose more heat in colder environments; whereas in hotter environments, it does not utilize enough heat. As per ASHRAE (2013), there are numerous psychological and physiological factors that influence the thermal comfort in humans; but, there are six major factors that affect thermal comfort of occupants in buildings: metabolic rate, clothing level, air temperature, mean radiant temperature, air speed, and humidity (Figure 7). The human body is naturally capable of adapting with the different outdoor temperatures and human adaptability to environmental temperatures is

due to psychological factors that can change with time. Thermal comfort in buildings also leads to enhanced productivity and better health for its occupants. Thermal neutrality is attained when heat dissipated by human metabolism achieves an equilibrium with its surroundings. Architects and engineers incorporate natural ventilation, passive techniques and proper enclosure designs for HVAC systems in buildings to achieve thermal conditions most likely to satisfy needs for comfort. It is easier and more efficient to design systems for thermal comfort when there are predictable weather conditions. But, with the change in climatic conditions, especially increase in outdoor temperature, the indoor temperature and thermal comfort is likely to be affected. In this situation, air conditioning loads increase whereas the heating energy loads per unit area decrease (Aebischer, Jakob, & Catenazzi, 2007). In their book "*Kinetic Architecture: Design for Active Envelopes*", Fortmeyer and Linn (2012) mention that architects, while designing building facades, can take inspiration from human skin, as it is the most versatile human organ. It separates inside from outside and protects our body from the environmental damages. Building facades should be as adaptable and active as human skin. There are many examples from nature from which architects and engineers can take inspiration. Biomimetic forms and functions for architectural designs can serve as solutions for climatic adaptability issues for our coming future.



**Figure 7: Thermal interaction of human body and environment (ASHARE, 2013)(p.8.2)**

#### *1.4 Adaptability*

Adaptability in architecture is the quality of being flexible and able to adjust with change in ongoing activities and environment. Adaptability plays an essential role in sustainable architecture. Socially, adaptability allows occupants to safely communicate with the spaces they are in. On individual human level, adaptability helps in achieving comfort, environmental quality, health and safety for users of the building. Economically, adaptability allows buildings to be more efficient (in terms of resource consumption) and have thus a potentially longer life cycle. Environmentally, adaptability allows buildings to reduce energy consumption and minimize the effects of extreme climatic conditions

(Nakib, 2010). To achieve and implement the notion of adaptability in architecture, we must think about how to successfully blend nature, machine and technology.

Historically, we have seen architects getting inspired by nature to design either in terms of forms or function. There has always been an interest in relating the biological world to engineering, architecture, art and science. We can see the same biological inspiration in the work of famous artist and architect Leonardo Da Vinci. From his drawing of flying machine to bat wing investigation to Vitruvian man, all of them reflect his understanding of nature as an inspiration for design. The study of nature is an incredibly powerful concept for architects, engineers, and artists to understand—that design can not only be seen in forms, functions or orders, but also in nature’s tendency to adapt. From human beings to other living species, from the physical form of Earth’s surface to its atmosphere, all co-exist and interact in one environment. In this process, they tend to modify their environment which further goes into responsive modifications (Brownell & Swackhamer, 2015). Learning from this process of interaction and modification, we can bridge between organic and inorganic. Nature, too, builds a relationship between its environment. Similarly, architecture can be made responsive and adaptable to build new relationships between people, spaces and climate. But how do we make our building adaptive, responsive, flexible or even transformable? What exactly do we learn from nature and how can we use it for our benefit? These are few questions that every architect and designer need to address when considering formulating bio-inspired architecture.

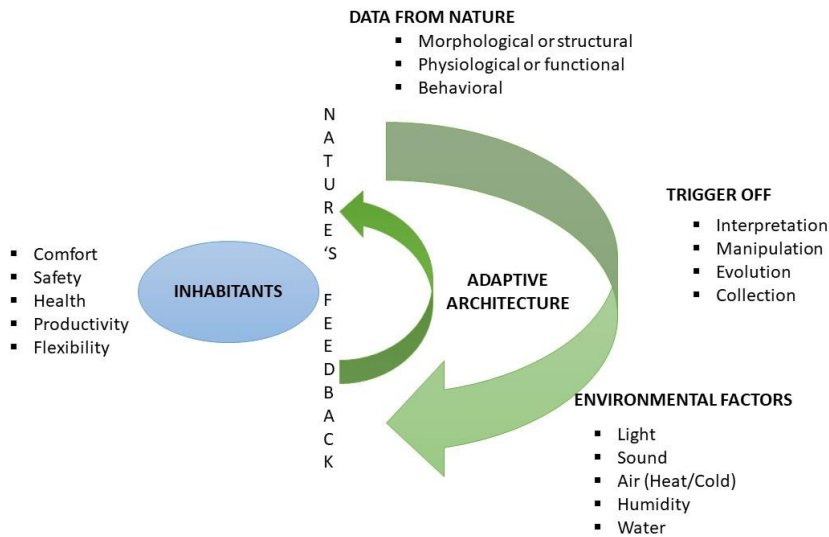
## CHAPTER 2: ADAPTIVENESS FRAMEWORK

In the previous chapter, we discussed basic idea of adaptability and nature, and how architects should learn from it. But how do we learn from nature? How do we implement what we learn from it?

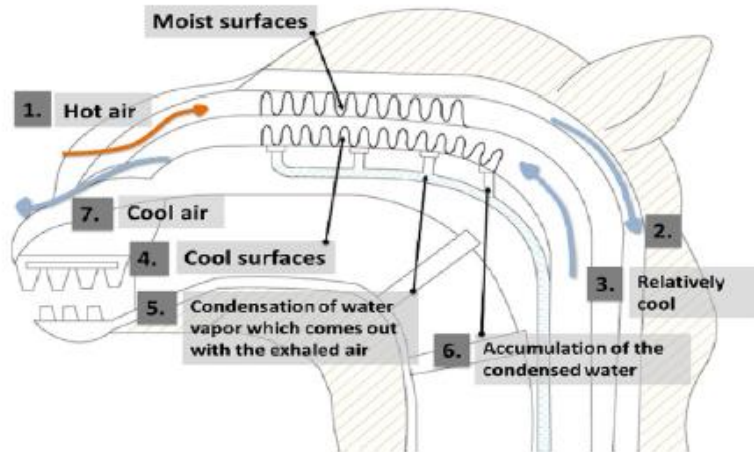
### *2.1 Nature as a Model*

As designers, we need to emulate nature's genius and use it to enhance our designs. This thesis argues that the quest for more efficient and effective ways to repair the mess created by humans is through nature. Learning from the natural processes and using them to aid the development of mankind is called Biomimetics or using "nature as a model." Imitating nature is easy but is not always successful. But, learning the logic behind the natural processes, systems, and researching natural forms before using them for our benefit is what using nature as a model means (Figure 8). Due to complexity of structures and tendency of growth in living organisms, the natural science, a branch of life sciences grabs attention of architects and designers quite often. Adaptation and evolution in living organisms in relation to their environment occurs in three ways: morphological, physiological and behavioral (Lopez, Rubio, Martin, & Croxford, 2017). Morphological or structural aspects are related to the shape, size, form or structure of a living organism that helps them to survive. An example is a nose of a camel. Camels are usually found in the deserts with hot and arid climatic conditions in which their body structure helps them survive harsh conditions. Camels have countless adaptation techniques that can be exploited in architecture. Camel's nose functions in such manner that it makes use of two principles of physics: (1) cooler air holds less moisture and (2) the rate of evaporation and condensation is faster when surface area is greater. As compared to human nose, the camel's nose has an intricate labyrinth of narrow passageways called the "Turbinates".

These are spongy passageways with large surface area for water and heat exchange (Shahda, Abd, & El Mok, 2018). Camels can decrease the water loss due to evaporation from its respiratory tracks by either reducing the temperature of exhaled air or by extracting water vapor from air (preventing its loss to the environment). The camel’s nose acts as both a humidifier and a dehumidifier as its head and brain help in the cooling process of air. Camel is one such example based in form and structure that can inspire architectural design and push architects toward a more sustainable approach (Figure 9). There are other endless examples in nature that can be implemented for climatically adaptive architecture.



**Figure 8: Nature as a Model- (developed by author)**



**Figure 9: Analysis of a camel's nose (Shahda, Abd, & El Mok, 2018)**

Physiological or functional aspect is related to the way a living organism functions and how it systematically responds to external stimulus. As an example, molecular process in mangroves enables the roots of the tree to live in poor oxygen level sediments. These trees can also survive in places where soil salt contents are high. Mangroves can filter out the salts at the surface of its roots, which makes them fit to survive in such environments in comparison to other plants. Studying physiological properties of adaptation of one such example in nature and applying it to architecture can be inspiring.

Behavioral aspects also relate to how living organisms act and the way organisms conduct and respond to their environment. As an example, *Mimosa Pudica*, also known as shameplant, folds its leaves inward in reaction to contact – a reflex mechanism to curb predators. These were some examples of living organisms in nature who have certain physical, behavioral or functional properties that can be used as a part of design methodology to facilitate the transfer from biology to architecture. Another similar methodology was explained by Brownell and Swackhamer (2015) in their book

“*Hypernatural: Architecture’s New Relationship to Nature*”, where they proposed that architects who pursue life sciences in their work, get inspired from specific characteristics of living organisms, like behavioral, genetic, and epigenetic, to reflect on their designs.

The behavioral approach is a pre-construction process in which most of the design work takes place during initial setup of the project. It allows the project to characteristically change throughout like the behavioral change of the organism. The projects outcomes are based on the setup and how behaviorally it is intended to happen (Brownell & Swackhamer, 2015). As an example, Figure 10 the architectural experiment constructed in MIT Media Lab called the Silk Pavilion uses the behavioral characteristics of silkworms and its ability to produce 3D cocoon out of single multi-property silk thread. This behavior of silkworm was studied and deployed as biological printers to design the pavilion and to fabricate a secondary structure. The team investigated the computational schema of silkworms to determine the shape and material of their dome. (Figure 11)



**Figure 9: Silk Pavilion at MIT; Placement of silkworms to study their patterns**





**Figure 10: Silk Pavilion Dome at MIT Media Lab**

The genetical approach is used during construction phase where inspiration from biology is taken from genes. Genes are the building blocks of living organisms that carry information from one generation to another. They are responsible for growth and development. The genetic evolution is explained with the conception of birth of living organism where characteristics of the organisms grow and develop in them with amalgamation of genetic information and environment (Brownell & Swackhamer, 2015). As an example, Achim Menges and Jan Knippers from Institute of Computational Design and Construction at university of Stuttgart, Germany, researched the layered structure of lobster shell for the ICD/ITKE pavilion (Figure 13). They used their understanding of the pattern of woven carbon fiber thread on the skin of lobster to replicate the process for the pavilion. The genetic information of pattern is replicated using a robotic arm and embedded code used for its movement (Figure 12). The result of this highly efficient structured pavilion is because of the combination of robotic fabrication and biomimetics.



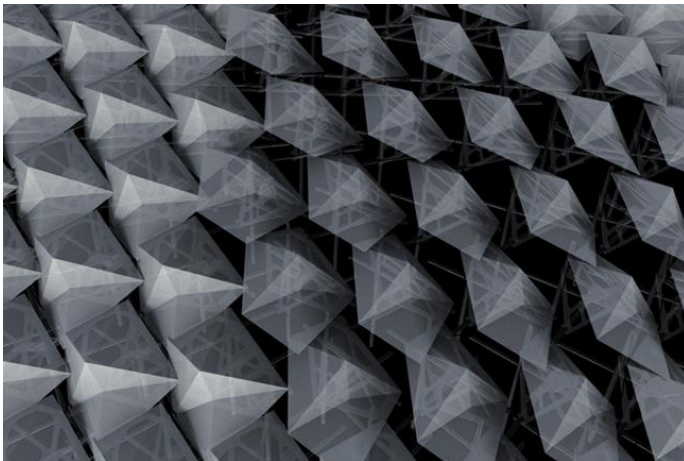
**Figure 11: Robotic arm fabricating ICD/ITKE Research Pavilion, Stuttgart, Germany, 2012**

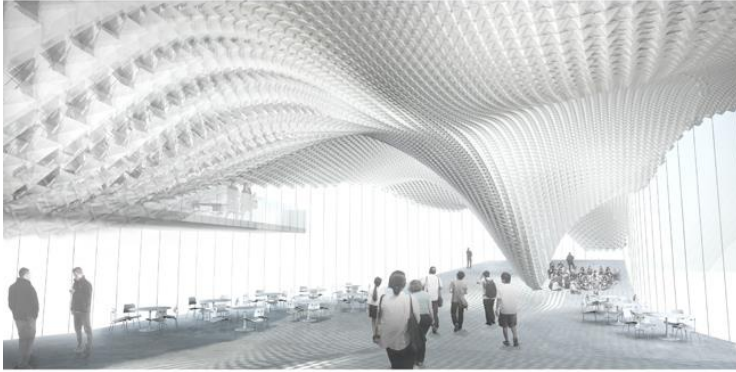


**Figure 12: ICD/ITKE Research Pavilion by Achim Menges and Jane Knippers, Stuttgart, Germany, 2012**

Epigenetic approach, which is a post-construction process, is another method of designing with nature. Epigenetic is related to non-genetic effects on gene declaration. It is simply the effects of external forces on organism characteristics in contrast with internal (genetic) forces (Brownell & Swackhamer, 2015). For example, University of Michigan's Taubman

College of Architecture and Urban Planning funded a project in 2010 by RVTR known as the Stratus project. This is an ongoing research investigation on dynamic interior building skins. The kinetic system of the skin has a potential of sensing and responding to its environment. The skin cells open and close like gills of a fish in response to movements, change of air quality, light, noise, thermal gradients, etc. Just like a living organism reacts to its environment, similarly, epigenetic projects are programmed with a logic to automatically sense the environment and respond. They adapt with the help of sensors, computer programming and use of engineered materials to change their properties automatically (Figure 14).

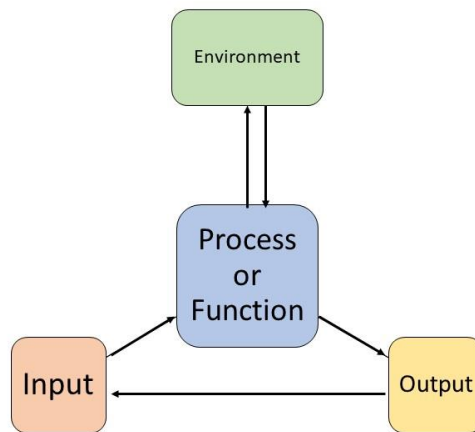




**Figure 13: Stratus Project by RVTR, Ann Arbor, Michigan, 2011**

## *2.2 Nature as Feedback*

Every living organism within a system is influenced by their actions and its environment. Many organisms in the system respond to the feedback model (Figure 15).



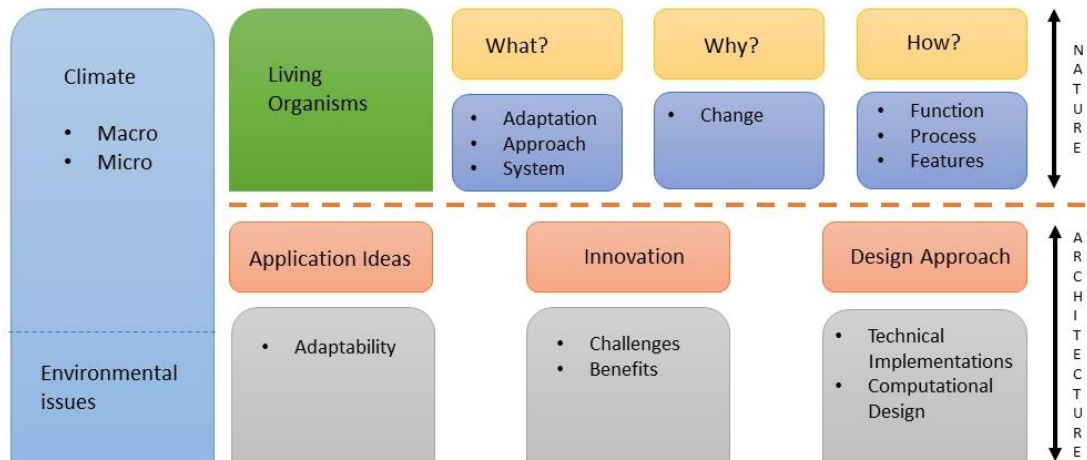
**Figure 14: Nature's Feedback Model- (developed by author)**

As an example, imagine a bird flying in a flock. A bird's constant flying speed becomes the input. Its eyes and lateral lines sense the distance between other birds in the flock. The information that is received by the bird's environment becomes useful for the internal processes. According to the input information, processors make internal corrections to the speed and direction values. These new values of speed and direction are used as input values in the feedback model.

### *2.3 Technology of Nature*

Designing successful bio-inspired adaptive buildings requires a certain role of technology to help make it responsive, flexible or transformable enough with respect to its environment. Adaptive architecture is like a machine that is dynamic, flexible and responsive, same as nature. From the early nineteenth century, scholars have suggested that technology has the same evolutionary principles as living organisms. The aim of technology is not antinatural as it works directly with the forces of nature and process to go beyond the capabilities of nature. Let's not forget that humans have used technology to destruct nature by causing pollution, environmental hazards and global warming. But we cannot blame technology for its antinatural outcomes as it is a human-controlled operation, which can be steered into the direction that is beneficial for both nature and mankind. To make technology work in our favor, we need to understand similarities between machine and nature and what computational technology can do for us in the field of adaptive architecture

## CHAPTER 3: DESIGN & TECHNOLOGY APPROACH TOWARDS ARCHITECTURE OF CHANGE



**Figure 15: Design & technology approach to bio-inspired adaptable architecture (Lopez, Rubio, Martin, & Croxford, 2017))**

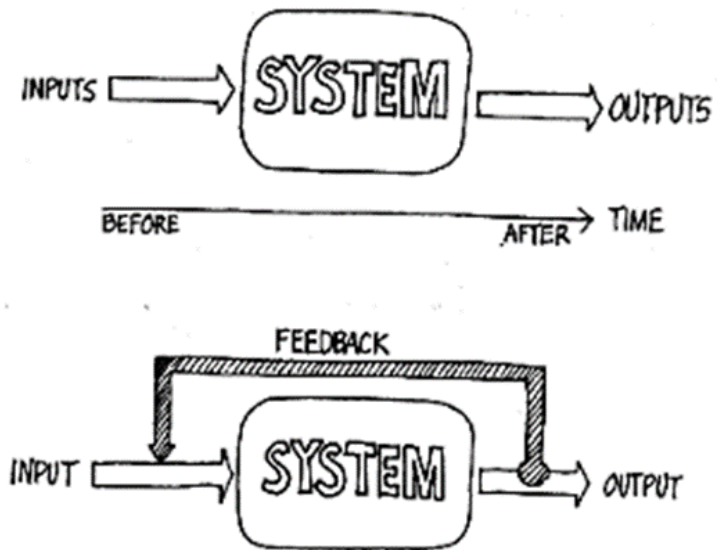
### 3.1 Cybernetics: *Catching up with Past and Present*

The term *cybernetics* stems from κυβερνήτης which is a Greek word for steering, first appeared in antiquity with Plato. In 1834, in an essay, *Essai sur la philosophie des sciences*, André-Marie Ampère, French physicist and mathematician coined the term "cybernetique" to describe civil government science (Tsein, 1954). In the year 1947, French philosopher and historian, Georges Canguilhem, in his lecture, *Machine et Organisme*, described organisms in terms of mechanistic principles. He put forward the understanding of biology in terms of technology and machine. He explained machines with reference to structures and functioning of an organism. This idea was put forward in the

new sciences of Cybernetics by Norbert Wiener in his book, Cybernetics, defining the study of controls and communications in the animal and the machine (Yiannoudes, 2016). Wiener described the idea of information feedback and self-regulation based on the understanding of biology, machine, and social processes. He suggested that it is possible to design a new kind of machine that can be responsive to its environment and can work on the principles of living organisms.

Cybernetics, as we know today, applies when a system being analyzed incorporates a closed signaling loop—originally referred to as a "circular causal" relationship—that is, where a system's action generates some change in its environment and that change is reflected in the system in some way (feedback) and triggers a systemic change (Figure 17). By late 1940s and 1950s, scientists started studying intelligent behavior of humans and animals to develop complex machines that was a mere dream before. The advocates of cybernetics talked in terms of living organisms as machines and machines as living organisms. Cybernetics bridges the gap between organic and inorganic, the natural and artificial, while accepting the complexities of respective system organizations.

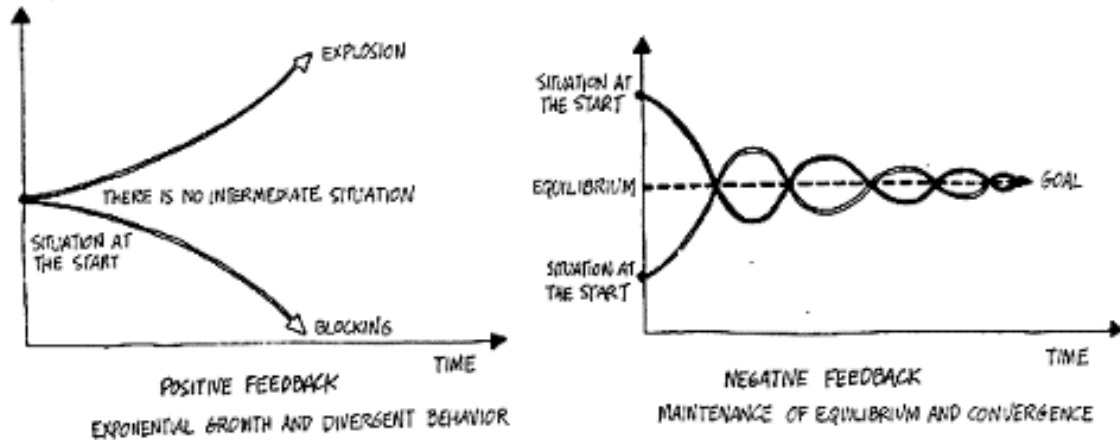




**Figure 16: Feedback loops of Cybernetics (Heylighen, Joslyn, & Turchin, 2000)**

In terms of cybernetics, in complex systems, transformation occurs where there are inputs and outputs. The inputs are the result of the influence of the environment on the system, and the outputs are the environmental impact of the system. Input and output are separated, as in before and after, or past and present. In every feedback loop, information about the outcome of a transformation or action is returned from output in the form of input data to the system input. If these new data facilitate and accelerate the transformation in the same direction as the preceding results, they produce positive feedback—their effects are cumulative (Heylighen, Joslyn, & Turchin, 2000). If the new data results in the opposite direction from previous results, they will produce negative feedback—their effects will stabilize the system. While there is exponential growth in the first case, equilibrium is maintained in the second.





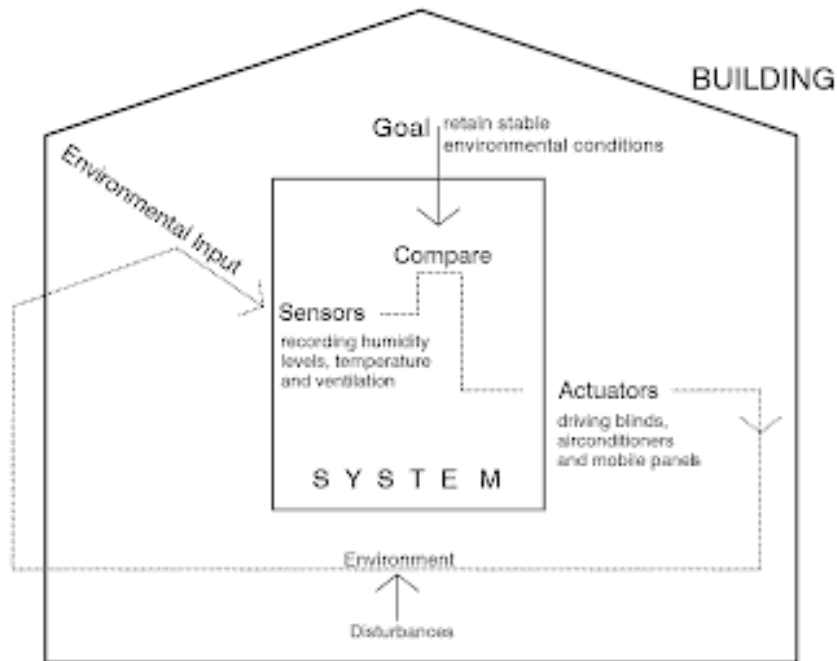
**Figure 17: Positive and Negative Feedback (Heylighen, Joslyn, & Turchin, 2000)**

According to Heylighen, Joslyn and Turchin (2000), “Positive feedback leads to divergent behavior: indefinite expansion or explosion (a run-off to infinity) or total blocking (a run-off to zero). Each plus involves another plus; there is a snowball effect. For example, proliferation of cancer cells. Negative feedback leads to behavior that is adaptive or objective-seeking: maintaining the same level, temperature, concentration, speed, direction. In some cases, the objective is self-determined and preserved in the face of evolution: the system has produced its own purpose (Figure 18). For example, maintaining the composition of air or oceans in the ecosystem or the concentration of glucose in the blood. In other cases, humans have determined the goals of the machines.”

Based on self-regulatory systems, physiologist Walter Cannon coined a term “homeostasis” which is a tendency to achieve a state of equilibrium in animal bodies to minimize energy loss in relation to environmental changes. Cybernetics considers the model of homeostasis as a negative feedback model in which loss of information is very low.

In 1970s, new cybernetics emerged in multiple fields, but was especially embraced in biology. Heinz von Foerster—whose work initiated a new direction in cybernetics—most succinctly stated the difference that separates the two orders of cybernetics. The first order is the cybernetics of observed systems. The second order is the cybernetics of observing systems (Glaserfeld, 2002). In the second approach, cybernetics was based on more suited organizations that humankind discovers in nature—organizations that were not invented by humans. One characteristic of the emerging new cybernetics considered in that time by Felix Geyer and Hans van der Zouwen, according to (Bailey, 1994), was “that it views information as constructed and reconstructed by an individual interacting with the environment.” Another characteristic noted was that the “transition from classical cybernetics to the new cybernetics involves a transition from classical problems to new problems. These shifts in thinking involve, among others, (a) a change from emphasis on the system being steered to the system doing the steering, and the factors that guide the steering decisions; and (b) new emphasis on communication between several systems which are trying to steer each other” (Bailey, 1994) (Page 163).

In 1972, Charles Eastman suggested that architecture could be formulated as self-regulatory feedback system that can adjust user needs in a dynamic environment (Yiannoudes, 2016). In 1975, as an example of homeostasis buildings, Nicholas Negroponte discussed machine-controlled environment in terms of greenhouses with opening and closing roofs. Greenhouse thermostats can control, decode and encode information to achieve thermal comfort level of plants. Later, Michael Fox explained homeostasis system in buildings as “responsive indirect control system” in kinetic architecture (Figure 19). Such systems are centrally computer programmed to receive information from environmental sensors as an input and sends appropriate signals through regulatory feedback to initiate motion in architectural elements (Yiannoudes, 2016).

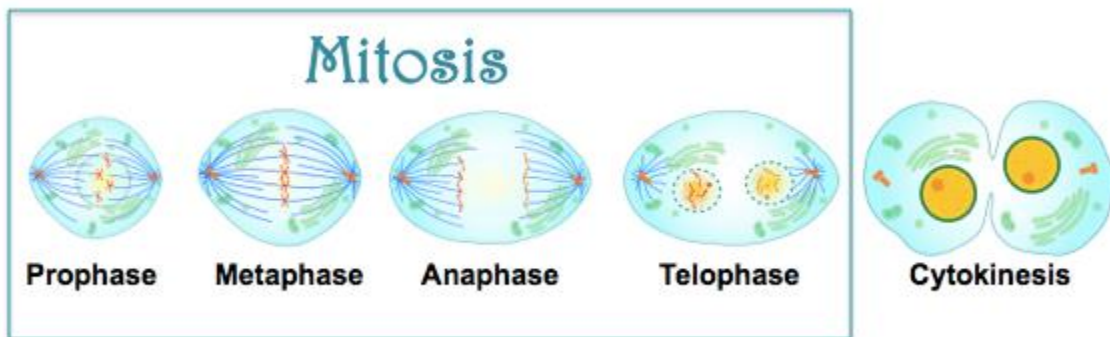


**Figure 18: Michael Fox's explanation of Homeostasis building**

In a scenario, where we know in advance the needs of occupants and an overall goal, a homeostasis system in a building can constantly adjust internal environment of the building through feedback. But a homeostasis architecture would work in an environment with constant fluctuation and operational changes when needs are predefined.

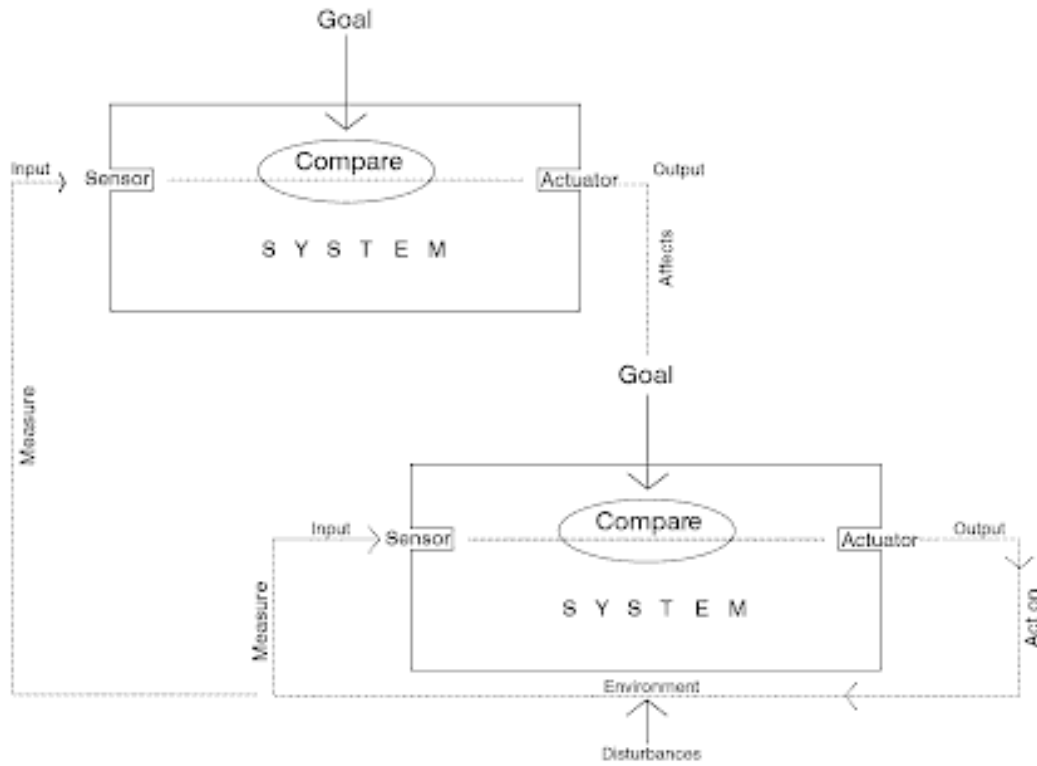
Between 1968 to 1975, Heinz and Foerster proposed the second order of cybernetics that explored the role of observer in formation of the system and positive feedbacks. A positive feedback system occurs in a loop in which effects of a small disturbance on a system includes an increase in the magnitude of the perturbation. It enhances and amplifies an effect by affecting the process that gave rise to it. Second order of cybernetics developed due to findings in other fields like chemistry and genetics and matured when the concept of “*Autopoiesis*” was introduced. Derived from the Greek word  $\alpha\upsilon\tau\omicron-$  (auto-), meaning ‘self’ and  $\pi\omicron\iota\eta\sigma\iota\varsigma$  (poiesis), meaning ‘creation or production’ which refers to a system capable of reproducing and maintaining itself. Autopoiesis was originally introduced to

explain the system description of natural living systems. Living systems are open self-organizing life forms that interact with their environment. These systems are maintained by flows of information, energy and matter. An example of such a system is biological cells. For example, the eukaryotic cell consists of various biochemical components such as nucleic acids and proteins and is organized into bounded structures such as the nucleus of cells, different organelles, a cell membrane and cytoskeleton (Figure 20). While homeostasis model uses information to maintain system order through interaction with the environment, the autopoietic system is autonomous and closed, constantly reproducing and regenerating the components it develops (Yiannoudes, 2016). As an autopoietic system is process based, it is more useful socially than technologically. To deal with machine and technological systems, another contrasting concept known as Allopoietic systems. Allopoiesis is the process by which a system produces something different from the system itself. One example of this is an assembly line where the final product (for example a car) is separate from the production machines.



**Figure 19: Various Phases of Mitosis**

Second order of cybernetics helped in providing a framework for developing complex systems. Second order of cybernetics system and autopoietic system lead to the development of self-organizing and complex adaptive systems that we use today for designing kinetic and responsive architecture (Figure 21).



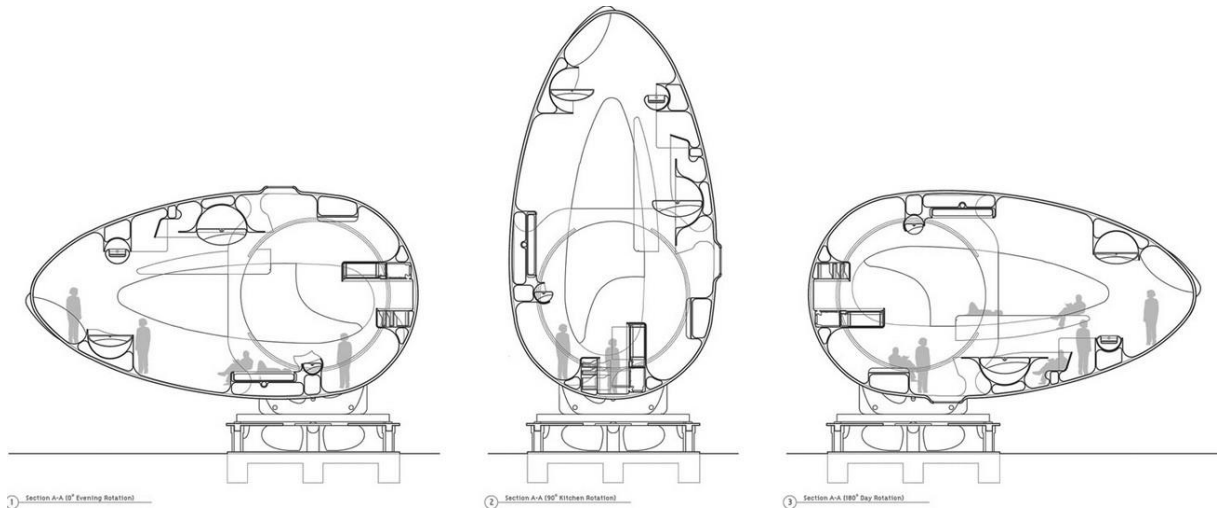
**Figure 20: Second order of Cybernetics system**

### *3.2 Transformable, Flexible and Responsive Design*

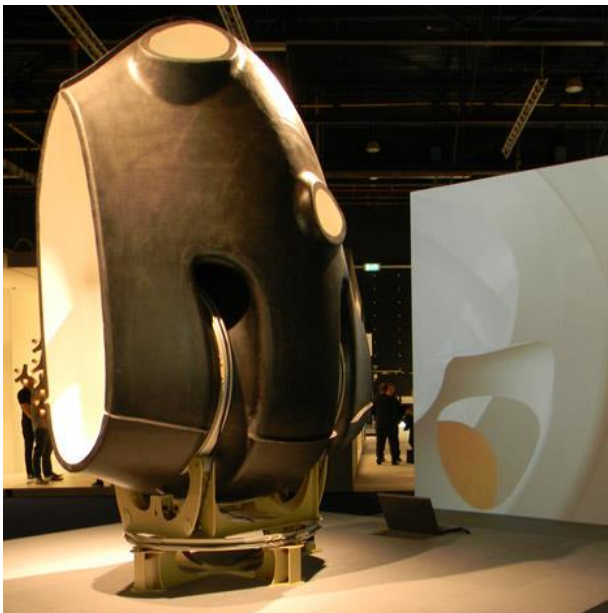
In the beginning of the 1960s, the first concept of adaptive architecture, as we understand today, was born due to development in the fields of cybernetics, artificial intelligence, and information technology. After the 1970s, not much happened for two decades with an exception of Jean Nouvel’s Institut du Monde Arabe in 1989, Paris. It was the first large scale building to have an adaptive and responsive façade. By 1990, with the greater attention to building energy demands and increasing capacity to monitor and manage energy use, building envelopes became the focus of technological innovations and advancements. The focus shifted from using passive techniques to creating energy barriers to block heat gain or loss towards harvesting energy from the environment and channeling

to where it was needed. Architects and designers started to incorporate mechanically activated shading devices and ventilation systems. In 1990s, the doubled skin façade with integrated controlled and operable vented air cavity started to emerge. In the last decade, high-performance building envelopes have entered architecture giving way to dynamic, kinetic and adaptive facades. The concept of adaptability and responsiveness is not limited to building envelopes. There is a growing interest in dynamic structures that could change the overall shape and internal configuration of the building, either in response to environmental conditions or different programmatic arrangement (Kolarevic & Parlac, 2015).

If it does not change the building's form or shape, it can also be reoriented by rotation, so that it always presents a smaller area to the Sun. For example, Greg Lynn's RV (Room Vehicle) house prototype is a motorized compact-living cocoon that rotates to provide space for relaxing, sleeping and bathing (Figure 22). According to the designer (Figure 23), "The RV Prototype brings intelligent movement and compact comfort to the living space as an alternative by reducing footprint and material while also bringing the enthusiasm and activity of a theme park, a hamster ball, an exercise machine, a natural landscape or sporting equipment to the human living sphere." Another example designed by Nextoffice in Tehran, Iran, is the Sharifi-ha House that rotates in and out to protect interior spaces from exposure to the Sun and seasonal changes (Figure 24).



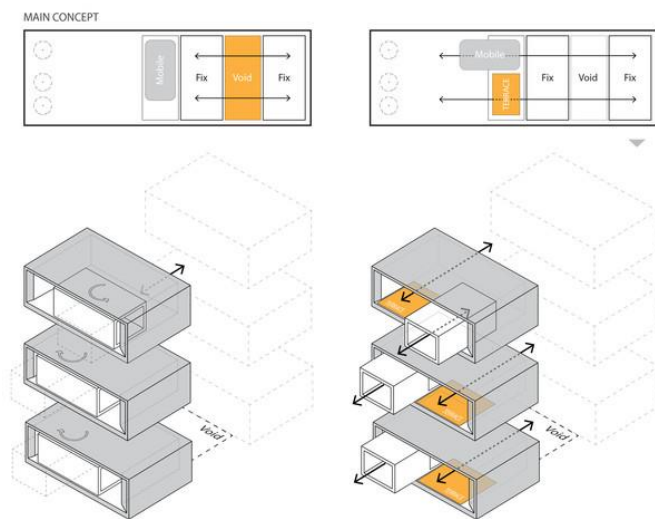
**Figure 21: Section of RV house (0° Evening Rotation, 90° Kitchen Rotation and 180° Day Rotation)**



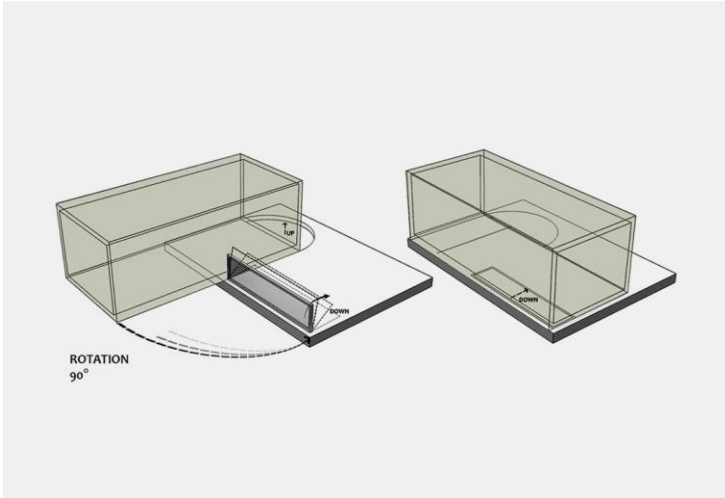
**Figure 22: Greg Lynn's RV House Prototype**



**Figure 23: The Sharifi-ha House**



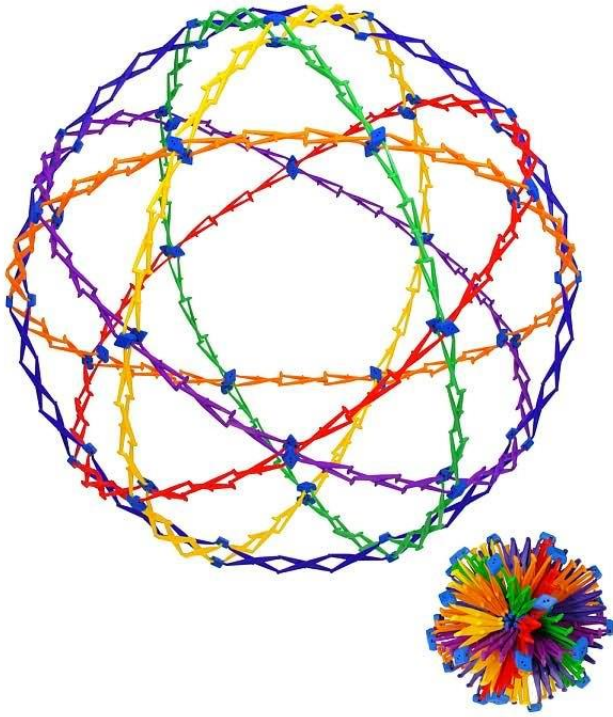




**Figure 24: Main concept showing the rotation of rooms in and out**

In Robert Kronenburg's book "Flexible: Architecture that Respond to Change," he discusses that for a building to be "flexible", it must be capable of "adaptation," to better respond to various requirements, "transformation," defined as change in shape and form, "movability," and "interaction." This can be achieved by installing intelligent building system driven by changing environmental factors.

The fundamental idea of transformable design forms comes from natural organism and their capacity to transform. While smooth transformation of size and shape is universal, it is rare in human-made objects. Creating transformable designs demands understanding of mathematics, mechanics and structural engineering. To successfully create transformable designs, the process should be complete, three dimensional, reversible and repeatable (Kolarevic & Parlac, 2015). Designed by Hoberman Associates, Hoberman Sphere is an example of transformable design that resembles geodesic dome but can fold down to a fraction of its normal size by a scissor-like action of its joints (Figure 26).



**Figure 25: Hoberman Sphere**

Expanding Sphere in Korea Aerospace Research Institute is an example installed in 2011. It has both form and behavior demonstrating the concept of biomimicry. Its continual expansion may be likened to the smooth, continuous growth patterns seen in nature like the opening of a flower blossom, or the expansion and contraction of the iris of an eye (Figure 27).





**Figure 26: Expanding Sphere, Korea Aerospace Research Institute**

### *3.3 Materiality*

Adaptation, behavior, responsiveness and growth are characteristics of living organisms that inspire architects. But structure, material, function and construction are important characteristics of architecture. To blend the two worlds, materials play the most important role. The words *material* and *materiality* carry ambivalent meanings in architecture. Material, as we know, is the matter from which a thing is, or can be, made; i.e., the physical aspect. Materiality is the quality or character of being material or composed of matter; i.e. the non-physical aspect. To design interactive and adaptive architecture, architects need to understand materiality of smart materials. Smart materials, also called intelligent or responsive materials, are designed with one or more properties that can be significantly modified by external stimuli, such as stress, moisture, electrical or magnetic fields, light, temperature, pH or chemical compounds, in a controlled fashion. Analyzing complex materiality of smart materials depends on complexity of behavior of change to ensure increase in the level of intelligence. The feature that distinguishes these materials from common materials is their ability to sense and react, gathering usage and environment information, and activating set of behaviors that ensure a specific and

increased interaction. To understand the materiality of smart materials, materials need to be analyzed for: reciprocity of action and reaction with user and environment; properties' variability, meaning that the effect of the reaction caused by the stimulus is reversible and contextual; the possibility of being programmed or combined (not only via software); the ability to connect to transfer and/or receive data (not only via a network) (Ferrara, Rognoli, Arquilla, & Parisi, 2018).

Recently in building industry, there has been an increase in the use of pneumatic actuation with ETFE-based system. HygroScope by Achim Menges, relies on inherent properties of material for it to be a responsive design. Another example of smart materials is the Living Glass prototype designed by David Benjamin and Soo-in Yang that is created by a cast silicone membrane in which slits were lined with Flexinol, a shape memory alloy wire manufactured by Dynalloy. It shrinks when an electrical current is applied to it and then returns to its original shape when the current is cut off (Figure 28).



**Figure 27: The Living Glass**

Designing with responsiveness and flexibility as basic concept, an effective overall design strategy is required to be integrated into a project that employs intelligent systems that can accommodate physical, behavioral and material changes.

### *3.4 Change and Growth*

Bio-inspired designs require the understanding of change and growth to develop aspects of adaptation. We can rely on a framework of “genetic program” that can modify itself in changing environmental factors. Bio-inspired designs need to be performative, operational in large scale and should inherit behavior of materials to address the changing needs. Organic and biological designs inherit information from growth in forms and requires careful investigation of behavioral patterns for dynamic changes.

## CHAPTER 4: CASE STUDIES

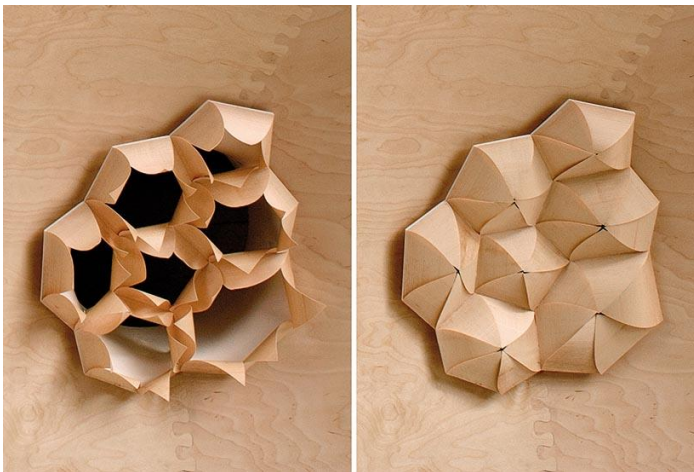
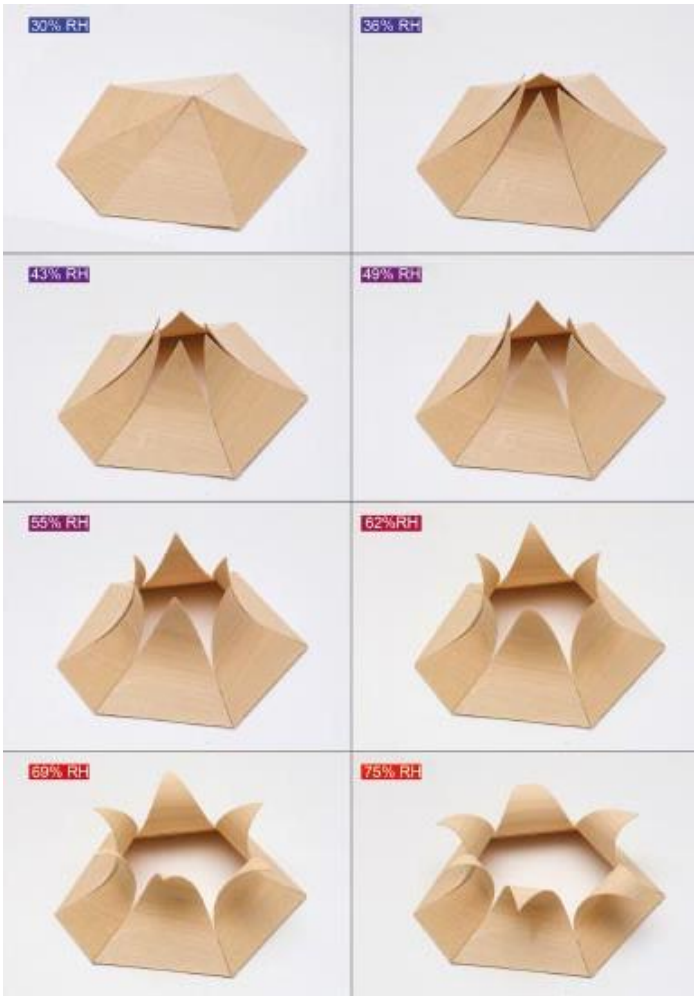
In this chapter, we analyze bio-inspired responsive and adaptable architectural projects that employ intelligent systems, smart materials and computational techniques to perform better with climate change.

### *4.1 HygroScope+HygroSkin Architecture*

HygroScope, also referred to as meteorosensitive pavilion, is one of the best examples in recent times that explores climate responsive architecture and inherent behavior of material in combination with computational morphogenesis. Developed by Achim Menges Architect, Frankfurt, HygroScope—Meteorosensitive Morphology was commissioned by Centre Pompidou Paris for its renowned permanent collection. HygroScope is a material system that is a responsive system achieved with wood-precisely cut into veneer with a combination of synthetic fiber-reinforced polymer (Fox, 2009). Being one of the oldest and most common material of construction, wood has the hygroscopic capacity which is well understood but not applied as much.



**Figure 28: Biological principle of hygroscopic material system of conifer cone reacting to moisture change**

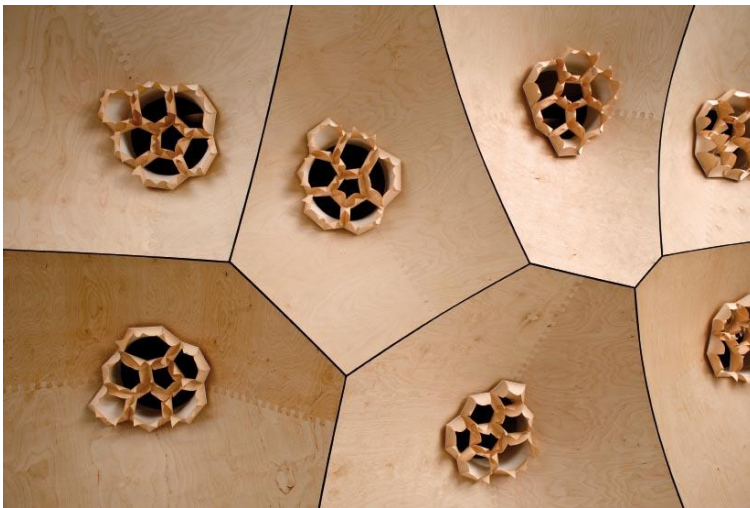


**Figure 29: Hygroskin inspired by spruce cone**



The HygroSkin–Meteorosensitive Pavilion project explores a new mode of architecture that is climate-responsive. This project uses material self-responsive capacity for it to be environmentally responsive rather than just relying on technical equipments (Figure 30).

Inspired by spruce cones, HygroSkin open and close based on change in humidity, which makes it a passive, moisture driven process that requires no energy or additional mechanism (Figure 29).

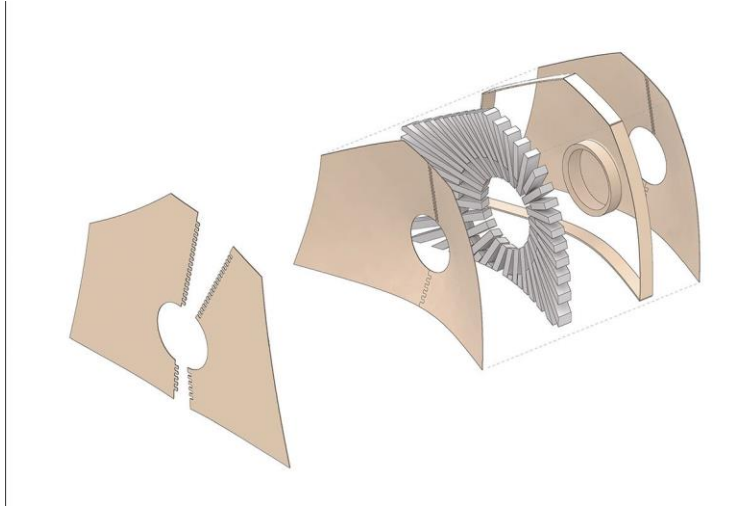


**Figure 30: Close-up photo of HygroSkin in open state at low relative humidity**

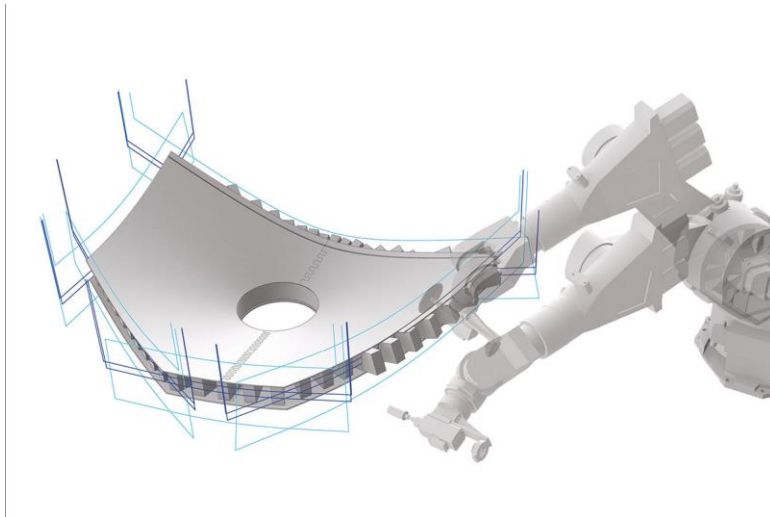


**Figure 31: HygroSkin – Meteorosensitive Pavilion in Stadtgarten, Stuttgart**



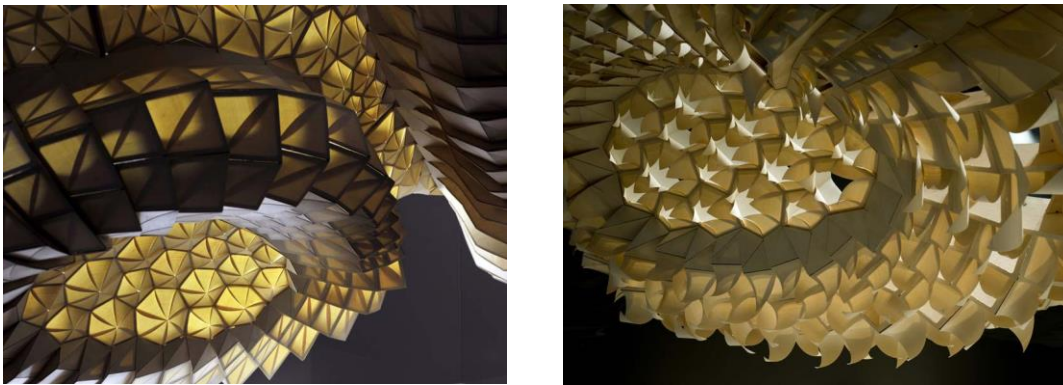


**Figure 32: Exploded view of a module's buildup: initially planar plywood panel (left), elastically self-formed plywood panels with sandwich core (right)**



**Figure 33: Generation and simulation of the machine code for robotic sawing and trimming**

Achim-Menges on their website says, “The project taps into several years of design research on robotic prefabrication, component-based construction and elastically self-forming structures (Figure 34). For this pavilion a computational design process was developed based on the elastic behavior of thin planar plywood sheets and the material’s related capacity to form conical surfaces. The computational process integrates the material’s capacity to physically compute form in the elastic bending process, the cumulative structure of the resulting building components, the computational detailing of all joints and the generation of the required machine code for the fabrication with a 7-axis industrial robot. Each component consists of a double layered skin, which initially self-forms as conical surfaces and is subsequently joined to produce a sandwich-panel by vacuum pressing. Final form definition on the modular panels, to precise tolerance levels, is achieved through robotic trimming (Figure 33). The structural capacity of the elastically bent skin surfaces allows for a lightweight, yet robust system, constructed from very thin plywood components” (Menges, 2013) (§ 11).



**Figure 34: Opening and closing of the installation**

HygroScope: Meteorsensitive Morphology project takes a different approach in adapting the ingrained dimensional change of wood as the trigger mechanism for adaptive shape change (Figure 35). According to Fox (2009), as mentioned in his book, *Interactive Architecture: Adaptive Word*, “The actual movement is controlled by changing the specific

material parameters: the fiber directionality, the layout of the natural and synthetic composite, the length-width-thickness ratio, the element geometry and most importantly: the humidity control during production process. The responsive behavior is controlled in a way that the basic material element can adapt to either opening or closing when exposed to the same stimulus”.

The installation is displayed in a transparent glass case at Permanent Collection, Centre Pompidou, Paris, and has a visually floating surrounding. It opens and closes in response to its surrounding humidity and is located in one of the most stable, climate-controlled spaces in the world (Figure 36).



**Figure 35: HygroScope: Meteorsensittive Morphology Installation display**

## 4.2 Al Bahar Tower

Designed by Abdulmajid Karanouh at Aedas Architects, Al Bahar Tower is one of the most innovative skyscraper adaptive façade design that takes its inspiration from nature and culture. In cultural context, Al Bahar Tower is inspired from the *mashrabiya* screens, which are a type of wooden screens used in traditional Islamic architecture of the Middle East (Figure 37). The dynamic movement of this façade takes its inspiration from the native climatically responsive plants that move with the movement of the Sun.



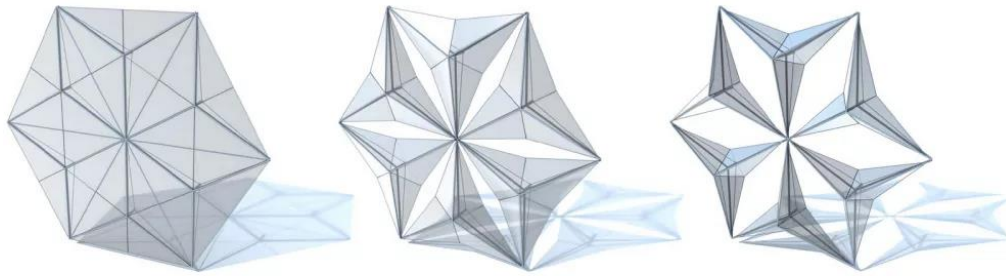
**Figure 36: Al-Bahar Tower**



**Figure 37: Dynamic mashrabiya-inspired from the past and from adaptive natural systems-folding and unfolding concept following the movement of the Sun (Karanouh, 2015).**

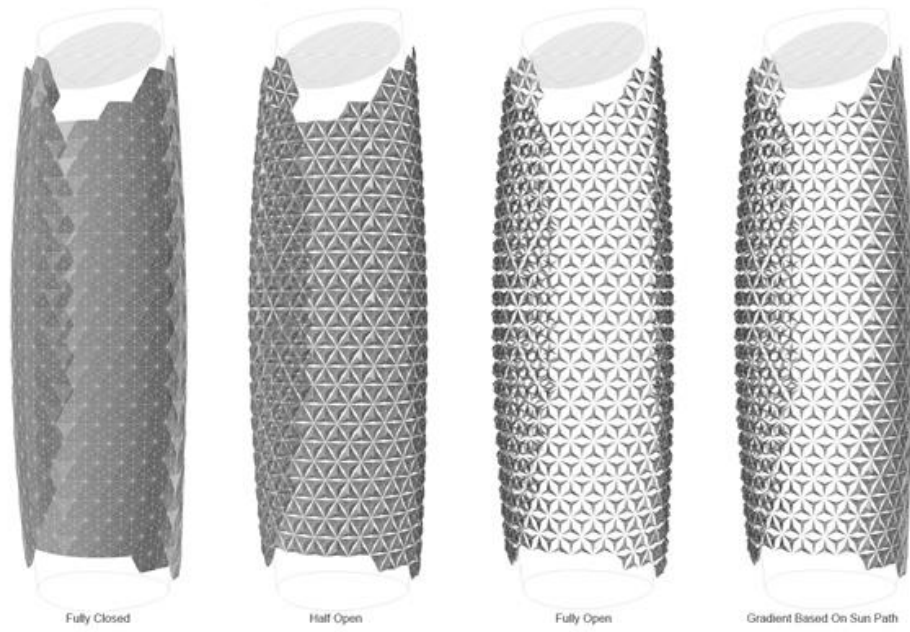
The dynamic mashrabiya is comprised of triangulated units with unique kinetic shading system subdivided into six triangular flat frames that fold like an umbrella at various angles. It provides fins and louver like geometries in different directions and positions (Figure 38).





**Figure 38: Mashrabiya units at unfold, midfold and maximum-fold positions**

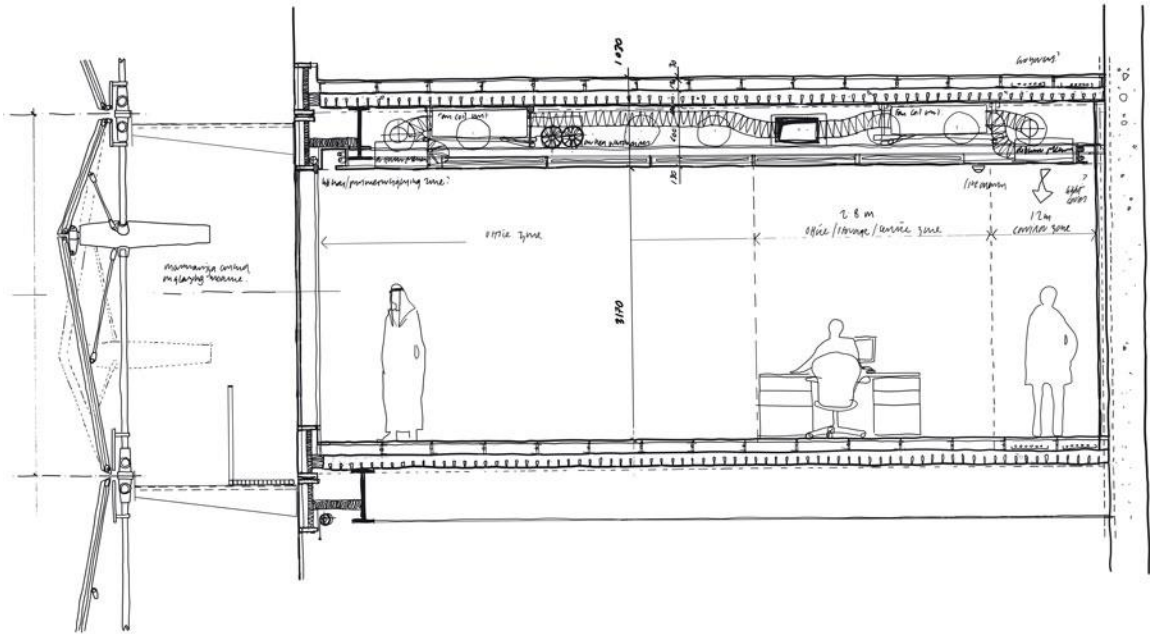
This 25-floor tower consists of 1049 units fitted to each tower, covering the east, south, and west zones, leaving the north face, which has no exposure to the direct sunlight. When any zone of the façade is directed to sunlight, the mashrabiya units deploy into their closed state providing shade to the inner glazing (Figure 40,41).



**Figure 39: Details of Mashrabiya System**



**Figure 40: Different layers of façade system**



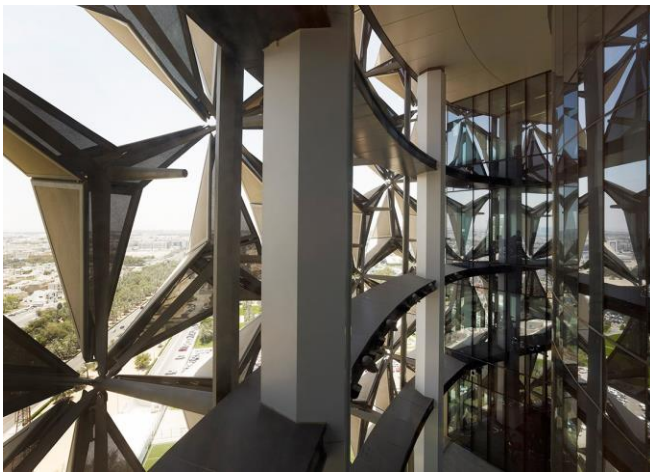
**Figure 41: Section drawing of shading screen and tower interiors**

These features help providing comfortable spaces in extreme temperatures like 50°C and humidity up to 100% (Figure 42). Designers were careful about not to ridicule the traditional system or directly mimic the natural systems as they tried to reclaim the sustainable features from bio-inspired strategies to enhance adaptability (Fox, 2009). The mechanism is driven by centrally located screw-jack linear actuators that provide 85% open area and is powered by electrical outlet at each floor. The parametric modeling and computational algorithms rendered design principles into performance-based mechanisms that can adapt to changing environment.





**Figure 42: Installation of Mashrabiya Screens**



**Figure 43: Interior office spaces at Al Bahar Tower**

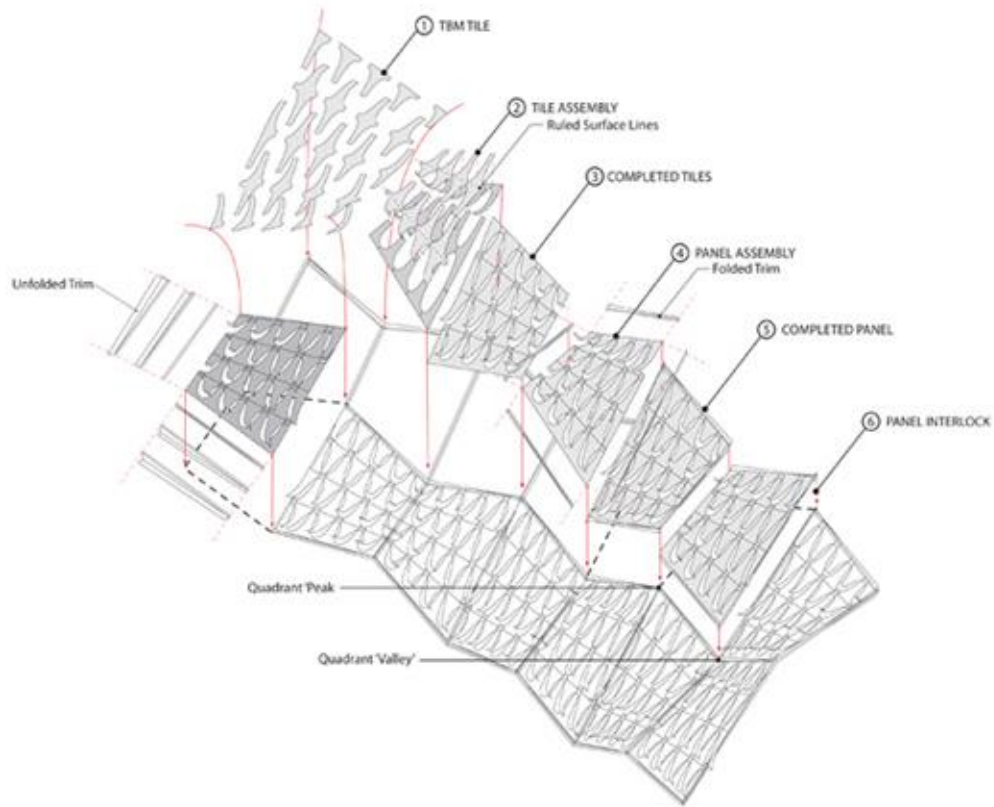
#### *4.3 BLOOM*

Designed by DO | SU Studio Architecture, BLOOM is a research installation that is displayed in Materials and Application Gallery in Los Angeles. Bloom brings together material experimentation, structural innovation, and computational form and patternmaking into an environmentally responsive form. It is a Sun-tracking instrument,

indexing time and temperature, with a shape alluding to a woman's Victorian-era undergarment (DO|SU, 2018). Bloom is a 26-foot-tall open-air pavilion clad in gleaming bimetallic strips. Bimetallic strips are composite skin designed to shape-shift with changes in temperature. Bimetals are made of two types of sheet metal with contrasting coefficients of thermal expansion (Figure 46). On exposure to direct Sun, material expands at a faster rate causing laminated sheet to curve upward (Brownell & Swackhamer, 2015). The concept of Bloom focuses on the capacity of architecture to adapt for human benefit. It is one of the most promising designs for future of responsive architecture (Figure 45).



**Figure 44: Bloom**

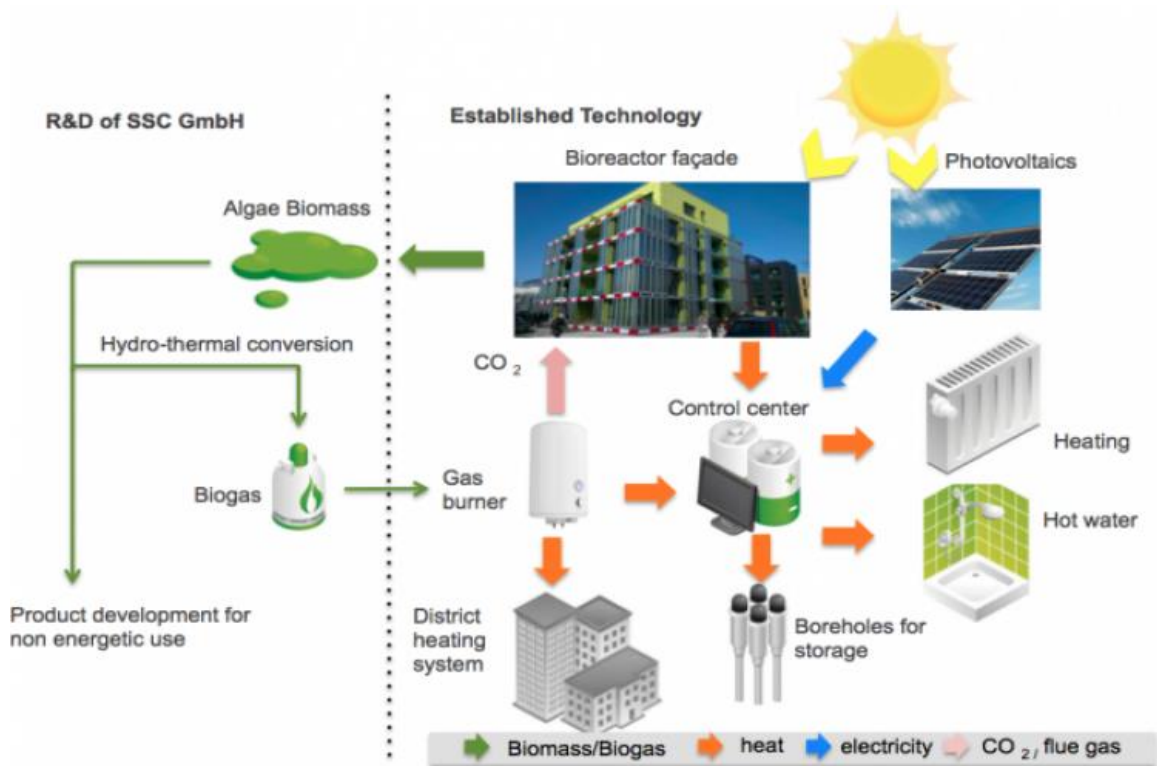


**Figure 45: Panel details of Bloom**

#### *4.4 BIQ House*

The first building in the world to have a bioreactor façade, BIQ house is natural, efficient and distinctive (Figure 48). Situated in Hamburg, Germany, Bio-Intelligent Quotient is the first algae powered building in the world. Splitterwerk Architects and Arup came together to develop world’s first bio-adaptive façade that is composed of microbe-infused glazing panels (Figure 49). The system uses living microalgae to harvest solar power while providing shade (Brownell & Swackhamer, 2015). BIQ is a passive house with two differently designed façade types. The side of the building that face the sun have a second outer shell that is developed in the façade itself. Microalgae—which are not longer than bacteria that are produced within this shell—enable the building to supply its own

energy. Intense sunlight accelerates the process of photosynthesis which drives the microbial growth within the liquid infused panels. The bio-adaptive façade of BIQ house is named as SolarLeaf and is in a form of vertical algaculture or algae farming. According to EPEEB (2015), “Apart from generating energy using the algae biomass harvested from its own façade, the façade then collects energy by absorbing the light that is not used by the algae and generates heat, like a solar thermal unit does, which is then either used directly for hot water and heating, or cached in the ground using borehole heat exchangers.” (Figure 47)

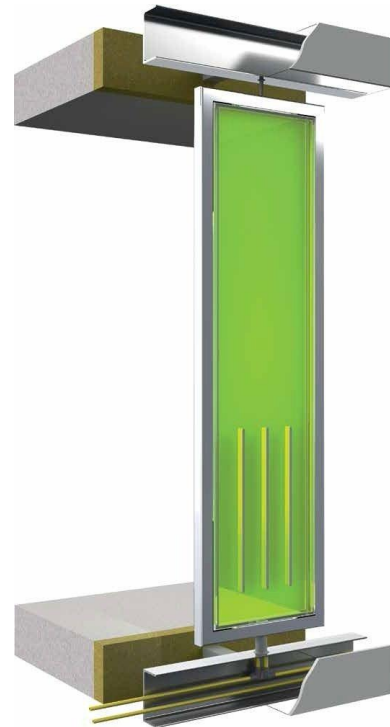


**Figure 46: Energy generation and use in BIQ House**





**Figure 47: BIQ House**



**Figure 48: Microalgae infused glazing panels: SolarLeaf**

EPEEB (2015) (¶ 7) states, “The bioreactor façades on the southeast and southwest sides of the building (200 square meters) are used for production of biomass and heat. They consist of 129 Sun-tracking reactor modules called photobioreactors (PBRs), 70 cm wide,

270 cm high and 8 cm thick, arranged in groups. The PBRs are mounted on a steel frame that is simultaneously used for wiring and supporting the vertical axis. The PBRs are filled with water (culture medium), in which microalgae are cultivated. As a nutrient, CO<sub>2</sub> is added to the culture, for which flue gas from a biogas-fueled microCHP (combined heat and power unit) is used. The CO<sub>2</sub> converts the growing algae to biomass”.

## CONCLUSION

This thesis provides a conceptual framework for the design of bio-inspired adaptive architecture in order to achieve climatically sound design.

Getting inspiration from nature is not enough to produce adaptive building that address climate change.

Technology plays an important role with a deep understanding of materials, computational design and systems of living organism. With drastic change in climate, learning about system adaption from nature can solve a lot of problems for humankind and provide better living conditions. It is easy to say that biomimicry or bio-inspired design concepts are essential to achieve adaptable design and maybe is one of the best solutions for climate change; but without expert knowledge of structures, materials, digital design and execution, it cannot be achieved.

Designers may get inspiration from complex, organic, free flowing architectural forms, but it essential to understand the execution, function, social and economic factors involved in the process of shaping complex bio-inspired architecture. This framework can be used to answer questions in the design of concepts necessary to generate buildings capable of regulating environmental aspects for comfortable conditions based on adaptation strategies from nature. Translating theoretical adaptiveness concepts into real living architectural designs that can interact within the environment can be a big challenge. Providing this framework is just a start.

## REFERENCES

- ACEEE. (2018). *The International Energy Efficiency Scorecard*.
- Aebischer, B., Jakob, M., & Catenazzi, G. (2007). Impact of climate change on thermal comfort, heating and cooling energy demand in Europe. *ECEEE*.
- Andersona, T. R., Hawkins, E., & Jone, P. D. (2016). CO<sub>2</sub>, the greenhouse effect and global warming: from the pioneering work of Arrhenius and Callendar to today's Earth System Models. *Endeavor*, 40:3, 178-187
- ASHARE. (2013). *ASHRAE Handbook - Fundamentals (I-P Edition)*. American Society of Heating, Refrigerating and Air-Conditioning Engineers, Inc. (ASHRAE).
- Bailey, K. D. (1994). *Sociology and the New Systems Theory: Toward a Theoretical Synthesis*.
- Brownell, B., & Swackhamer, M. (2015). *Hypernatural: Architecture's new relationship with nature*. New York: Princeton Architectural Press.
- DO|SU. (2018). Bloom. <https://www.dosu-arch.com/>.
- Economy, A. C. (2016). *The International Energy Efficiency Scorecard*.
- EPEEB. (2015). The BIQ House: first algae-powered building in the world. <http://www.buildup.eu/en/practices/cases/biq-house-first-algae-powered-building-world>.



- Ferrara, M., Rognoli, V., Arquilla, V., & Parisi, S. (2018). *Interactive, Connected, Smart materials: ICS materiality*.
- Fortmeyer, Charles D. Linn, R., & Linn, C. D. (2012). *Kinetic Architecture: Design for Active Envelopes*.
- Fox, M. (2009). *Interactive Architecture- Adaptive World*. Princeton Architecture Press, New York.
- GISS, N. G. (2018). *Global Land-Ocean Temperature Index*. NASA.
- Glaserfeld, E. v. (2002). *Cybernetics and the Theory of Knowledge* .
- Heylighen, F., Joslyn, C., & Turchin, V. (2000). *Principia Cybernetica Web (Principia Cybernetica, Brussels)*.
- Karanouh, Abdulmajida, & Kerber, Ethanb (2015). Innovations in dynamic architecture. *Journal of Facade Design and Engineering*. 3. 185-221. 10.3233/FDE-150040.
- Kolarevic, B., & Parlac, V. (2015). *Building Dynamics: Exploring Architecture of Change*.
- Kuhn, T. (1962). *The Structure of Scientific Revolutions*.
- Lopez, M., Rubio, R., Martin, S., & Croxford, B. (2017). How plants inspire facades. From plants to architecture: Biomimetic principles for the development of adaptive architectural envelopes. *Renewable and Sustainable Energy Reviews*.
- Menges, A. (2013). ICD University of Stuttgart. <http://www.achimmenges.net/?p=5612>.

- Nakib, F. (2010). *Toward an Adaptable Architecture Guidelines to integrate Adaptability in the Building*.
- NASA. (2019). The Causes of Climate Change. <https://climate.nasa.gov/causes/>.
- NASA. (2019). The Effects of Climate Change. <https://climate.nasa.gov/effects/>.
- Merhan M. Shahda, Mostafa M. Abd Elhafeez, Ashraf A., & El Mokadem (2018). Camel's nose strategy: New innovation architectural application for desert buildings. *Solar Energy*.
- Stanley, B. (2007). Global Climate Change-Impacts and Adaptation. *The Nature Conservancy*.
- Tsein, H. (1954). *Engineering Cybernetics*. Mc Graw Hill.
- Ward, J. (1994). The Industrial Revolution and British Imperialism, 1750-1850. *The Economic History Review*, 47(1), new series, 44-65. doi:10.2307/2598220.
- Yiannoudes, S. (2016). *Architecture and Adaptation: From Cybernetics to Tangible Computing*.